

WCND40HCS-12

MODEL 600

40 lb CAPACITY

THE

OPL (Computer) WASHER

DEXTER

COMPANY

OWNER'S BOOKLET INSTALLATION & OPERATION INSTRUCTIONS

TABLE OF CONTENTS

Page #

Safety Warnings	2
Maintenance Hints	2
Installation Instructions	3
Foundation Requirements	3
Mounting	3
Plumbing	3
Drain	3
Electrical	6
Fusing Requirements	6
Electrical Connections	6
Chemical Injection	7
Chemical Injection Hoses	7
Final Checkout	7
Operating Controls	9
Operating Instructions	10
End Of Cycle	11
Safety Door Lock	11
Motor Drive Indications	11
Computer Control Cycle Description	11
Programming Instructions - Editing Existing Cycle	12
Programming Instructions - Entering New Cycle	13
Washer Diagnostic Cycles	14
Cycle 31 Sequence	14
Rapid Advance Mode	16
Preset Cycle Information	18

LIST OF FIGURES

Figure 1-1 - Pedestal Mounting	4
Figure 1-2 - Floor Outline	4
Figure 1-3 - Machine Mounting Detail	4
Figure 2 - Washer Dimensions	5
Figure 3 - Electrical Power Connections	6
Figure 4 - Injection Signal and Connections	7
Figure 5 - Specifications Thoroughbred 900	8
Figure 6 - Water Usage	8

Figure 7 -	Push-button Control Switches	9
Figure 8 -	Recommended Detergent Quantity	10
Figure 9 -	Bath Setting Limits	11

Please read this information and retain for reference.

WARNING - THIS WASHER IS EQUIPPED WITH DEVICES AND FEATURES RELATING TO ITS SAFE OPERATION. TO AVOID INJURY OR ELECTRICAL SHOCK, DO NOT PERFORM ANY SERVICING UNLESS QUALIFIED TO DO SO.

IT IS THE RESPONSIBILITY OF THE OWNER TO CHECK THIS EQUIPMENT ON A FREQUENT BASIS TO ASSURE ITS SAFE OPERATION.

A machine should not be allowed to operate if any of the following occur:

- ! Excessively high water level.
- ! If machine is not connected to a properly grounded circuit.
- ! If the door does not remain securely locked during the entire cycle.
- ! Vibration or shaking from an inadequate mounting or foundation.

WARNING - FOR SAFETY

1. Always shut off power and water supply and wait a minimum of one minute before servicing.
2. Do not overload the washer.
3. Do not bypass any safety devices of this washer.
4. Do not use volatile or flammable substances in or near this washer.
5. Do not attempt to open door when cylinder is in motion or it contains water.
6. Keep all panels in place. They protect against shock and injury and add rigidity to the washer.

MAINTENANCE HINTS

DAILY

- ! Clean the top and the cabinet to remove residue.
- ! Clean the soap dispenser and lid.
- ! Check the drain valve for leaking and that it opens properly.
- ! Check the loading door for leaks. Clean the door seal of all foreign matter.
- ! Leave the loading door open to aerate the washer when not in use.

QUARTERLY

Always shut off power and water supply and wait a minimum of one minute before servicing.

- ! Check the V-belts for wear and proper tension.
- ! Clean lint and other foreign matter from around motor.
- ! Check all water connections for leaks.
- ! Wipe and clean the inside of the washer and check that all electrical components are free of moisture and dust.
- ! Remove and clean water inlet hose filters. Replace if necessary.
- ! Check anchor bolts - retighten if necessary

IMPORTANT: Replace any and all panels that were removed to perform daily and/or quarterly maintenance.

INSTALLATION INSTRUCTIONS

All washers must be installed in accordance with all local, state and national building, electrical, plumbing and other codes in effect.

WARNING - THESE INSTALLATION AND SERVICING INSTRUCTIONS ARE FOR USE BY QUALIFIED PERSONNEL ONLY. TO AVOID INJURY AND ELECTRIC SHOCK DO NOT PERFORM ANY SERVICING UNLESS QUALIFIED.

FOUNDATION REQUIREMENTS

This machine is designed for use on or over bare concrete floor - not to be used above combustible flooring. The washer must be securely bolted to a substantial concrete floor, or mounted upon a suitable base which is, in turn, securely bolted to a substantial concrete floor. CARE MUST BE STRESSED WITH ALL FOUNDATION WORK TO INSURE A STABLE UNIT INSTALLATION, ELIMINATING POSSIBILITIES OF EXCESSIVE VIBRATION. All installations must be made on sound concrete floors, 6" or thicker. Anchor bolts must be of a quality grade and a minimum of 5/8" diameter. Four (4) mounting bolts must be used.

MOUNTING

A concrete pedestal or steel mounting base which elevates the machine approximately 6" above the floor level is recommended to provide easy access to the loading door. Actual base height should be determined by application considering access to loading door, access to soap dispenser and height of loading carts. Allow a minimum of 24" of clearance behind the rear of the machine, to provide access for motor removal. Refer to Fig. 1-1 & 1-2 for machine bolt-down dimensions. Refer to Fig. 2 for overall washer dimensions.

If an elevated concrete pedestal is desired, it should be embedded into the existing floor. Anchor bolts should be 5/8" x 8", grade 5 or better, headed by a 4 inch square fish plate and should protrude 1 7/8 inches above the finished surface of the pedestal. EXPANSION ANCHORS ARE NOT RECOMMENDED FOR USE IN CONCRETE FLOORS OR PEDESTALS, BECAUSE THE ANCHORS ARE TOO CLOSE TO AN EDGE, CAUSING IT TO BREAK OUT. (See Fig. 1-1 and 1-3.)

PLUMBING

Water supply hoses are furnished with each machine. The threaded connections on the hoses are 3/4-11 2 NHT.

Separate hot and cold water lines must be provided, maintaining 30 PSI to 120 PSI water flow pressure.

DRAIN

The drain outlet tube at the rear of the machine is 3 inches in diameter. Any drain hose used must be lower than the drain valve to assure proper draining.

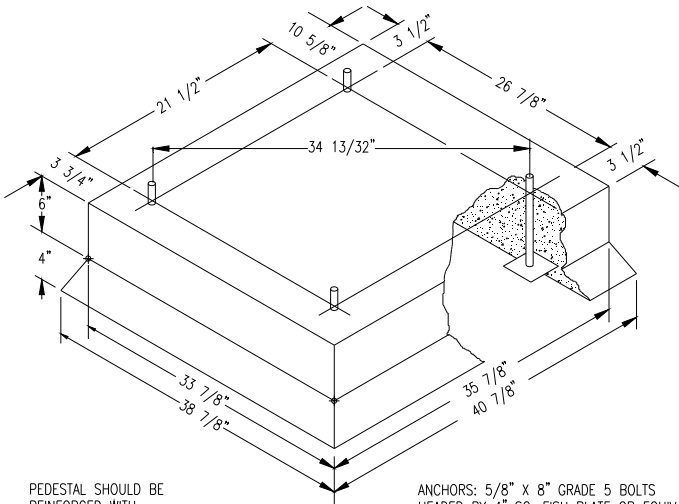

PEDESTAL SHOULD BE REINFORCED WITH MESH OR RODS.

ANCHORS: 5/8" x 8" GRADE 5 BOLTS HEADED BY 4" SQ. FISH PLATE OR EQUIV. (1 7/8" BOLT PROTRUSION)

CONCRETE PEDESTAL MOUNTING
Figure 1-1

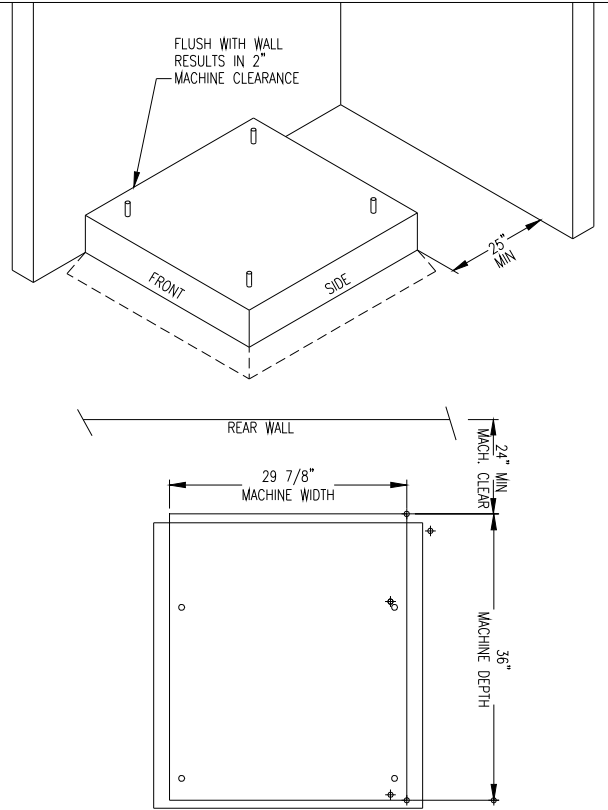

FLOOR OUTLINE
Figure 1-2

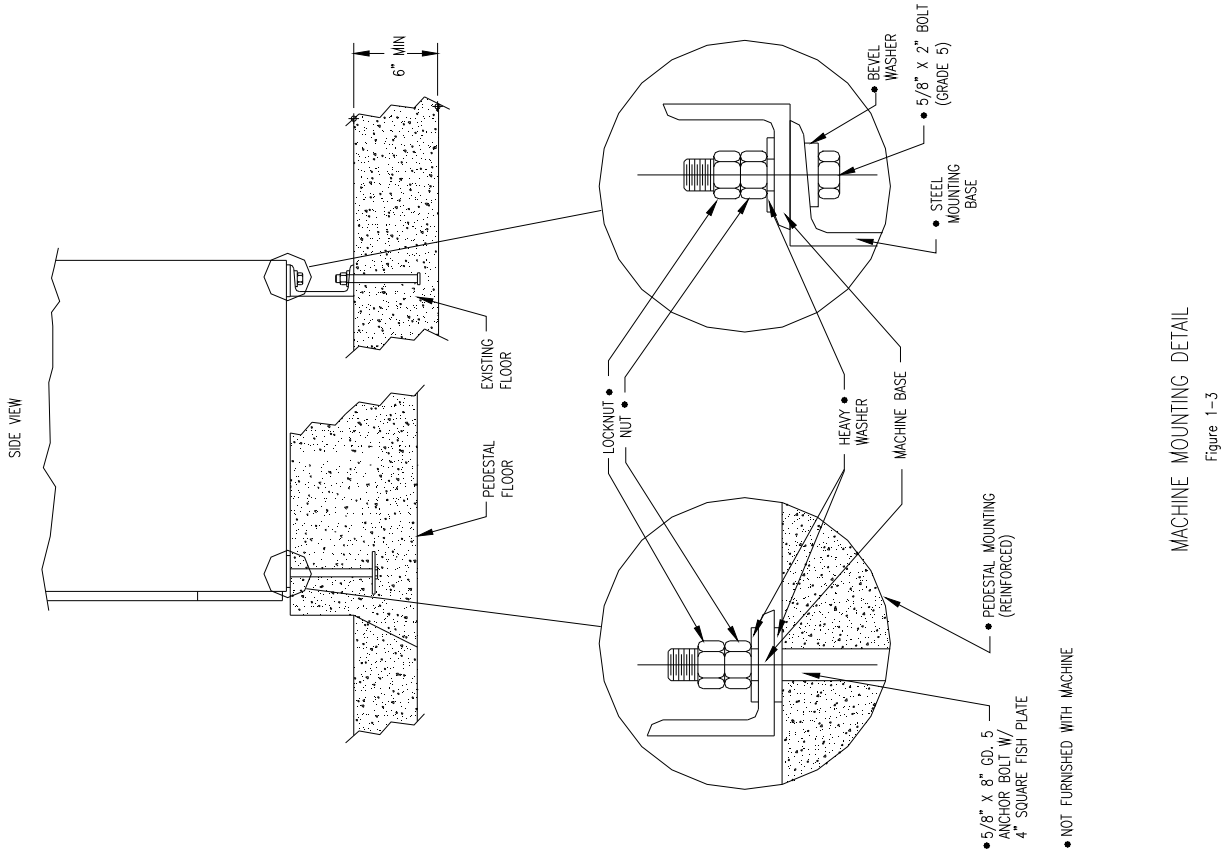

MACHINE MOUNTING DETAIL
Figure 1-3

600 SERIES INDUSTRIAL WASHER
MOUNTING DIMENSIONS
FIGURE 2

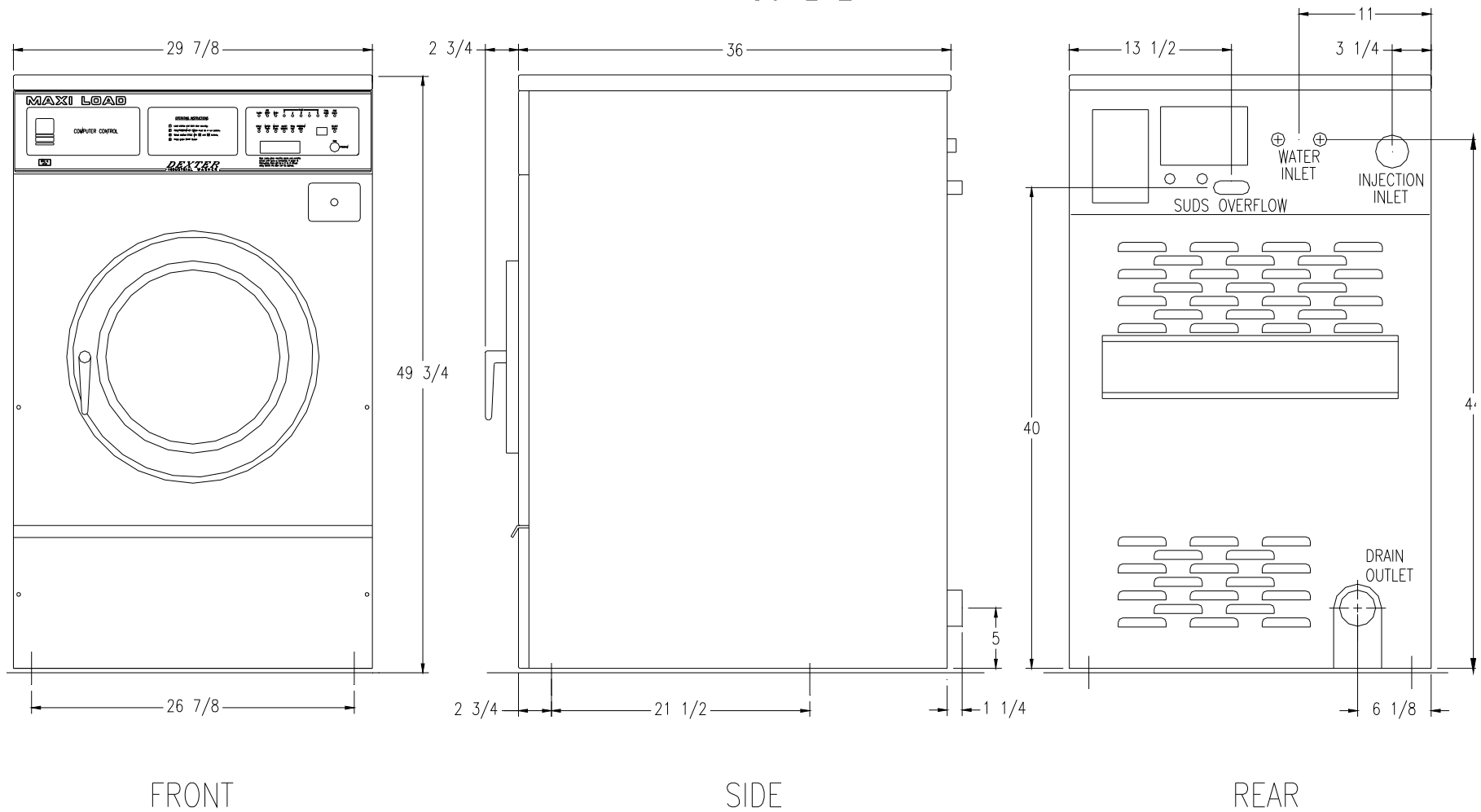

ELECTRICAL

WARNING
SHUT OFF POWER AND WATER BEFORE OPENING ANY SERVICE PANELS.

Dexter T600 washing machines are intended to be permanently installed appliances. The machine should be connected to an individual branch circuit not shared by lighting or other equipment. The connection should be sheathed in liquid-tight flexible conduit, or equivalent, with conductors of the proper size and insulation. No power cord is provided. Such connections should be made by a qualified electrician, in accordance with the wiring diagram. (Suggest minimum wire size of 12 ga.)

FUSING REQUIREMENTS

15 Amp Time Delay (Dual Element) Fuse(s) (or equivalent circuit breaker).

TO MAKE ELECTRICAL CONNECTIONS:

Remove screw and lift out cover located on upper left of machine (viewed from back).

Figure 3 - Electrical Power Connections

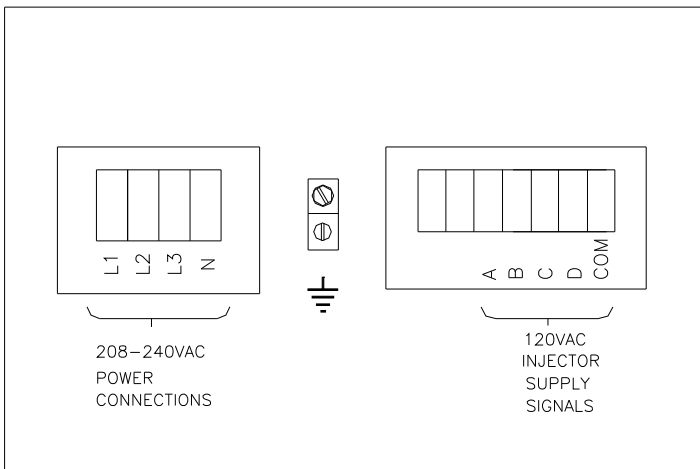

If power is 208-240-3PH-60HZ connect L1, L2, L3 and ground. (If there is a high phase it must be connected to L3.)

If power is 208-240-1PH-60HZ connect L1, L2 and ground.

IMPORTANT

FOR SAFETY AND PROPER EQUIPMENT OPERATION THE GROUND LUG MUST BE CONNECTED TO A GOOD EXTERNAL GROUND.

CHEMICAL INJECTION

Dexter T600 washing machines are intended to be permanently installed appliances. The machine is intended to have a chemical injection system operating with it. There are convenient electrical connection points for the injection pumps shown in Figure 3. Up to four (4) independent pumps can be controlled through the signals A, B, C and D. The injection pump signals are 115 VAC. The COM shown in Figure 3 is the common or return for these injection signals. The complete injection system can be connected to FL1 and FL2 for system power if other sources are not available. These connections require fusing which are not provided by Dexter (Dashed lines shown in Figure 3). The maximum current of the complete injection system is 7 Amps.

The four injection pump signals (A, B, C and D) are individually selected or in combinations by the programming within the selected cycle. The recommended signal connections are shown in Figure 4. The selection of the signal is explained in the Programming Instructions section of this manual.

FIGURE 4 - INJECTION SOURCE SIGNALS AND CONNECTION RECOMMENDATION

DEXTER RECOMMENDED CONNECTIONS	INJECTION PUMP SIGNAL	COMPUTER SUPPLY SIGNAL
DETERGENT	A	1
BLEACH	B	2
STARCH	C	3
SOUR/SOFTENER	D	4
	A AND B	5
	C AND D	6
	FUTURE USE	7
	NONE	0

CHEMICAL INJECTION HOSES

Chemical Injection hoses are to be inserted into the injection inlet at the upper right rear of the washer. These hoses should be inserted into the round PVC pipe a minimum of 14" and a maximum of 18" to eliminate chemical buildup in the pipe and/or restrict water flow to the tub. Secure the hoses as required.

FINAL CHECKOUT

After all mounting, plumbing and electrical work is completed, the washer should be checked for water leaks and proper functioning by first running each step in the diagnostic cycle (cycle # 31) and by running a complete cycle.

FIGURE 5 - THOROUGHbred 600 SPECIFICATIONS

MODEL	WCN40AFH
CAPACITY	6 CUBIC FT. (UP TO 40#)
CYLINDER DIM.	25" DIA. x 21 1/8" DEPTH
GROSS WEIGHT NET WEIGHT	656 POUNDS 622 POUNDS
ELECTRICAL	208-240 VAC, 60 HZ, 1 PH OR 3 PH
EXTRACTION FORCE	100 g=s
WASH SPEED SPIN SPEED	43 R.P.M. 531 R.P.M.
DRIVE SYSTEM	SOFT START REVERSING AC MOTOR DRIVE
WATER INLET	2 SOLENOID OPERATED VALVES FLOW RATE, 9 GAL./MIN. EACH FLOW PRESSURE, 30-120 PSI
DRAIN VALVE	3" OUTSIDE DIAMETER
PROGRAM CYCLES	30 USER PROGRAMMABLE CYCLES (29 OF 30 PREPROGRAMMED AT THE FACTORY) CYCLES TAILORED FOR SHIRT LAUNDRY, HOTEL/HOTEL, HEALTH CARE AND FOOD & BEVERAGE (SEE PRESET CYCLE INFORMATION TABLE)
TEST CYCLE	DIAGNOSTIC TEST PROGRAM
TEMPERATURES	USER SELECTABLE FROM 4 SETTINGS
MACHINE CONTROL: KEYLOCK	ADVANCE/RUN/PROGRAM
MEMBRANE	STOP/EXIT START/ENTER SCROLL UP SCROLL DOWN

FIGURE 6 - WATER USAGE

USAGE/BATH	LOW LEVEL FILL	HIGH LEVEL FILL
EMPTY CYLINDER - NO LOAD	12.6 gals.	18.6 gals.
FULL CYLINDER - LOADED		
Water required to fill bath starting with a dry load.	gals.	gals.
Water required to fill bath preceded by a drain without a spin.	10.6 gals.	16.4 gals.
Water required to fill bath preceded	gals.	21.4 gals.

by a drain with a spin.

OPERATING CONTROLS

There are four (4) switches that control the washer operation. Each switch is shown below followed by an explanation of each switch.

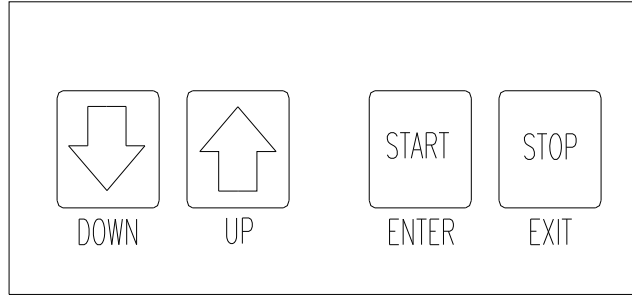

Figure 7 - Push-button Control Switches

STOP (RED) Push-button - Depress momentarily.

Stops the washer during the cycle. All washer cycle information is retained, the door remains locked and the water remains in the tub.

STOP (RED) Push-button - Depress and hold for 3 seconds or longer.

Stops the washer and clears the cycle. All washer cycle information is cleared, the water is drained and the door is unlocked. The washer is ready for the next wash cycle.

NOTE: The door lock safety mechanism will prevent the door from opening for up to 3 mins. when the washer is stopped during a cycle and the cycle cleared.

WARNING

**DEPRESSING AND HOLDING THE STOP IS AN EMERGENCY STOP BUTTON.
THIS DOES NOT DISCONNECT THE MACHINE FROM THE INPUT POWER.**

START (GREEN) Push-button - Depress momentarily.

Starts the cycle shown on the display. If the cycle was stopped in the middle, depressing the START will begin the cycle from the point at which the cycle was stopped.

SCROLL UP ARROW (BLUE) Push-button - Depress momentarily / depress and hold.

Scroll Up increases the cycle number displayed by one each time the switch is depressed. When the Scroll Up is held, the display cycle numbers will continue to increase until cycle # 30 (cycle # 31 in Programming Mode) is reached at which time the cycle number displayed will rollover back to cycle # 1.

SCROLL DOWN ARROW (BLUE) Push-button - Depress momentarily / depress and hold.

Scroll Down decreases the cycle number displayed by one each time the switch is depressed. When the Scroll Up is held, the display cycle numbers will continue to decrease until cycle # 1 is reached at which time the cycle number displayed will rollover to cycle # 30 (cycle # 31 in Programming Mode).

OPERATING INSTRUCTIONS

1. Ensure that power is on to the washer.
2. Ensure that the ADVANCE/RUN/PROGRAM keylock is in the RUN position.
3. Load the clothes loosely in the cylinder and latch the door securely. Be sure clothing does not get caught between the door gasket and tub front when closing the door.

NOTE: To begin closing the door, the handle must be in the horizontal position. After moving the door to the closed position, the handle must be turned down to the vertical position in order to latch the door for machine operation.

4. Select one of thirty cycles by using the SCROLL UP/SCROLL DOWN buttons to change the number indicated in the two digit LED display. The selection is made when the number indicated corresponds with the desired cycle.
5. If you are manually adding wash compounds, add low sudsing powdered detergent in the amount shown below into the detergent compartment on top of the machine. Location is illustrated on the black cover on the top of the machine. This compartment will be flushed during the WASH segment of the cycle. Rinse conditioners may be added to their own compartment if desired. This compartment will be flushed during the FINAL RINSE segment of the cycle.

	POWERED DETERGENT REQUIREMENT
THOROUGHbred 600	1/3 to 1/2 CUP

Figure 8 - Recommended Detergent Quantity

6. If you wish to manually add bleach during the cycle, add bleach in the round opening in the top of the machine. Location is illustrated on the black cover on the top of the machine.

NOTE: Any additional washing compounds may be added at the appropriate time by pouring into the round opening in the top.

7. Push the green START button to start the cycle.

The cycle time remaining is displayed throughout the cycle. The cycle number in operation can to displayed by pushing and holding START, then push SCROLL UP. The cycle number will be displayed as long as these two buttons are depressed.

Soak - At any time during the cycle, the red STOP button can be depressed to stop the washer. All washer cycle information is retained and the door remains locked. The washer will soak the load for 15 minutes, then agitate for 30 seconds. This will repeat until the cycle is started again. This feature allows for an extended soak if required. The washer cycle will continue when the START button is depressed.

The selected cycle can be cleared at any time by depressing and holding the STOP button for a minimum of three seconds.

END OF CYCLE

At the end of the cycle the machine stops, the END CYCLE LED lights, the alarm sounds and the loading door unlocks allowing unloading of the machine.

SAFETY DOOR LOCK

This machine is equipped with a Safety Door Lock which prevents opening the door if power is interrupted, until it is safe to do so.

If power failure occurs it will be necessary to wait 2 to 3 minutes before the door can be opened.

MOTOR DRIVE INDICATORS

There is a four digit, seven segment, display on the drive which can be viewed by removing the access cover at the top rear of the washer. There are also small L.E.D.s on the left and right edge of the display that can be viewed and used for troubleshooting. The four seven segment digits will change value depending on where the washer is during the wash cycle.

COMPUTER CONTROL CYCLE DESCRIPTION

The T600 computer control OPL machine has 30 different selectable cycles; 29 of the 30 cycles are preset with the most common industry applications. See the Preset Cycle Information sheets for complete cycle information. If these cycle settings do not meet the required application, each cycle is reprogrammable by the user simply and reliably.

Each cycle has up to 9 baths which are Flush, Prewash, Wash, Rinse 1, 2, 3, 4, 5 and Final Rinse/Extract. **There are five user selectable settings within each bath** to allow cycle tailoring to meet exact applications. The settings and the limits of each are shown in the table below. The Scroll Up/Scroll Down buttons are used to change the settings.

FIGURE 9 - BATH SETTING LIMITS

Settings for each bath	Setting Limits	Description
Cycle Time	0 to 30 minutes (1 min. increments)	The Cycle time (tumble) settings are 0 min. to 30 min. in 1 min. increments for each bath. If the setting is 0, then that bath is skipped over. For the Final Rinse /Extract bath, the minimum time must be 1 min.
Water Temp.	HOT, WARM, COLD and NO WATER	The water temperature setting is displayed as HH = hot, CH = warm, CC = cold and EE = No water bath. When the No Water bath is selected, the water level can be set to either high or low and NO Injection will be made even if the injection source is programmed.
Water Level	HIGH or LOW	The water level setting is displayed as HI for High level and LO for low level.
Injection	0 to 6	The injection source settings are 0 through 6 with 0 being no injection and settings 1

Source		through 6 relating to an injection source. See Recommended Injection Table.
Spin Time	0 to 10 minutes (1 min. increments)	The spin time settings are 0 min. to 10 min. in 1 min. increments. If the setting is 0, there is no spin for the bath. Final Rinse/Extract minimum setting is 1 min.

PROGRAMMING INSTRUCTIONS - EDITING EXISTING CYCLE

There are 29 preset wash cycles programmed into the washer at the factory. Although these cycles are common industry cycles, there may be a need to tailor the cycle to meet an exact application. This can easily be done with the following instructions. Note: It is recommended when changes are made to one or more of the preset programs that the cycle number and the changes be documented for later reference. Blank cycle sheets have been provided at the end of the Preset Cycle Information section.

1. Turn on the power to the washer.
2. Turn the Advance/Run/Program key to the Program position (Program Mode LED lights).
3. The Select Cycle LED is lit. Select the cycle to be edited by using the SCROLL UP/SCROLL DOWN buttons. The selection is made when the number displayed corresponds with the desired cycle.
4. Push the green ENTER button.

Once depressed, the first of the nine cycle segment LED's will light (top row). The cycle segments are: Flush, Prewash, Wash, Rinse 1, Rinse 2, Rinse 3, Rinse 4, Rinse 5 and Final Rinse/Extract. The Select Cycle LED is out.

5. Use the Scroll Up / Scroll Down buttons to light the cycle segment to be changed.

The sequence of steps below is repeated for each cycle segment until all required segments are edited. The previously stored parameters will appear as each part of the segment data is reviewed.

6. Push the green ENTER button.

The Cycle Time LED lights (lower row of LED's) and the segment LED is out. The tumble time for this segment will be shown on the display. If no change is required, then continue to the next instruction. If this value requires changing, then use the SCROLL UP/SCROLL DOWN buttons to change the tumble time in 1 min. increments to the desired value, then continue to the next instruction. Settings range is from 0 min. to 30 min. except for the Final Rinse/Extract segment where the setting range is 1 min. to 30 min. REMINDER: If the tumble time is set to zero, the segment will be skipped in the wash cycle.

7. Push the green ENTER button. (The wash time has now been entered.)

The Water Temperature LED lights and the Cycle Time LED are out. The water temperature for this segment is displayed. If no change is required, then continue to the next instruction. If a change is required, then use the SCROLL UP/SCROLL DOWN buttons to change the water temperature. {"HH" is all hot water, "CC" is all cold water, ACH" is an even mix of hot and cold water and AEE@ is a no water bath} When the desired water temperature is selected, continue to the next instruction.

8. Push the green ENTER button. (The water temperature has now been

entered.)

The Water Level LED lights and the Water Temperature LED are out. The water level for this segment is displayed. If no change is required, then continue to the next instruction. If a change is required, then use the SCROLL UP/SCROLL DOWN buttons to change the water level. {"HI" is a high water level and "LO" is a low water level} When the desired water level is selected, continue to the next instruction.

When the No Water bath is selected, the water level has no effect. Either water level can be selected.

9. Push the green ENTER button. (The water level has now been entered.)

The Injection Source LED lights and the Water Level LED are out. The injection source for this segment is displayed. If no change is required, then continue to the next instruction. If a change is required, then use the SCROLL UP/SCROLL DOWN buttons to change the injection source. See the Injection Source table for proper selection. If zero is selected, then no injection source is active for this segment. When the desired injection source is selected, continue to the next instruction.

When the No Water bath is selected, injection signals are prohibited by the electronic controller. The programmed injection source value is ignored.

10. Push the green ENTER button. (The injection source has now been entered.)

The Spin Time LED lights and the Injection Source LED are out. The spin time for this segment is displayed. If no change is required, then continue to the next instruction. If this value requires changing, then use the SCROLL UP/SCROLL DOWN buttons to change the spin time in 1 min. increments to the desired value, then continue to the next instruction. Settings range is from 0 min. to 10 min. except for the Final Rinse/Extract segment where the setting range is 1 min. to 10 min. REMINDER: If the spin time is set to zero, there will be no spin at the end of the bath.

11. Push the green ENTER button. (The extract time has now been entered.)

Once depressed, the Spin Time LED is out and the editing of one segment is complete. The next sequential cycle segment LED lights, unless the segment edited above was the Final Rinse/Extract segment. If the Final Rinse/Extract segment is edited, after step eleven, the cycle programming is complete and the machine will return to the Programming Mode awaiting a cycle select (Step 3).

To exit the programming mode, depress the red STOP button when one of the nine cycle segment LED lights is lit. The programming changes made prior to the program exit are retained and the cycle is updated.

PROGRAMMING INSTRUCTIONS - ENTERING NEW CYCLE

The T600 comes from the factory with 29 preset wash cycles programmed into the

washer. Although these cycles are common industry cycles, there may be a need to add a cycle to meet an exact application. This can easily be done with the following instructions. Note: It is recommended when cycle(s) are made the cycle number and the cycle steps be documented for later reference. Blank cycle sheets have been provided at the end of the Preset Cycle Information section.

The instructions for entering a new cycle are the same as the editing a cycle instructions. Again only the cycle segments required need to be programmed. All other segments can be left unprogrammed by ensuring a zero time value is entered in the Cycle time for each unused segment.

WASHER DIAGNOSTIC CYCLE

The diagnostic test cycle provided with every machine aids the user in verifying correct operation of the washer after scheduled maintenance and aids the user in identifying functional problems with the machine.

The diagnostic program, cycle 31, is an individual function test. This program tests most of the functions of the machine (water valves, drive system, door lock, etc...). The diagnostic program must be started from the program mode. **The keylock must be in the program position.**

Below are two important notes about the diagnostic cycle:

- ! Cycle Terminate - At any time during the diagnostic cycle, depressing and holding the stop button for a minimum of 3 seconds terminates washer activities and clears the cycle.
- ! Injection Signals - The injection signals are not tested during the diagnostic cycle.

Cycle 31 Sequence - Short individual function test

1. Close the washer door.
2. Turn the control key to the PROGRAM mode.
3. Select cycle 31 using the SCROLL UP/SCROLL DOWN buttons.
4. Push the green START button.

From this point, the operator must observe the functions of the washer to ensure correct operation. With the top removed, the activation of each function can be observed. Each step in this test will turn on an output on the I/O interface assembly. Each time an output is active, the corresponding RED LED on the I/O interface assembly will light. The outputs are clearly marked.

To end the test, push STOP and the machine will return to the programming mode with cycle 31 displayed. The sequence of operation for the diagnostic cycle is explained below:

- ! All indicators are lit and "00" is on the display. No other function of the washer is active.
- ! Push the SCROLL UP button. The display will show 01.

For each number in the test, the function will be active when the START button is pushed and will be inactive when the START button is released. Use the SCROLL UP to move from one function to the next.

! Step 1 - Lock the door.

! Step 2 - Turn on thermoactuator #1 (lock).

! Step 3 - Turn on thermoactuator #2 (unlock).

! Step 4 - Close the drain valve.

! Step 5 - Turn on the cold water to the tub.

The pressure switch low level setting can be tested at this point. The drain valve is closed and cold water is on for as long as the START button is pushed. When the water level reaches a low level, the water valve will turn off and no additional cold water can be added. (The time required to reach a low water is dependent on input water pressure. It may require several minutes.)

! Step 6 - Turn on the cold water to the dispenser.

The pressure switch low level setting can also be tested with this step. For details see Step 5.

! Step 7 - Turn on the hot water to the tub.

The pressure switch high level setting of the pressure switch can be tested at this point. The drain valve is closed and hot water on for as long as the START button is pushed. When the water level reaches a high level, the water valve will turn off and no additional hot water can be added. (The time required to reach a high water is dependent on input water pressure. It may require several minutes.)

! Step 8 - Turn on the hot water to the dispenser.

The pressure switch high level setting can also be tested with this step. For details see Step 7.

! Step 9 - Forward tumble.

! Step 10 - Reverse tumble.

! Step 11 - Open drain.

! Step 12 - Intermediate spin.

The I/O interface outputs labeled Reverse and Speed1 will be active (the two RED LED=s will light).

! Step 13 - Full speed spin.

The I/O interface outputs labeled Reverse, Speed1 and Speed2 will be

active (the three RED LED=s will light).

DO NOT USE STEP 14 IF YOU HAVE CUSTOMIZED CYCLES PROGRAMMED AS THIS WILL SET THE CYCLES BACK TO THE FACTORY PRESETS.

! Step 14 - Preset Cycles. Push START and hold, then push SCROLL UP. This will reset the DEXTER preset cycles back to the factory settings.

At cycle complete, switch the Advance/Run/Program switch to the Run position and the unit is ready to select a run cycle.

RAPID ADVANCE MODE

To enter the Rapid Advance mode, insert the key into the Rapid Advance/Run/Program lock and turn the key counter-clockwise (CCW). The Rapid Advance mode must be entered during the cycle. If the cycle has not yet started, press the "DOWN" button or the "UP" button to choose a cycle and then the "START" button to begin the cycle.

To advance to the next step in the cycle, push both the "UP" and "START" buttons at the same time. The display will show "Ad" (advance).

If advancing during a bath, all water valves will turn off and the drain will open until the "open drain" step is completed. The cycle will then continue to the next bath or to the spin of the current bath if the programming includes spin time.

If advancing during a chemical injection of a bath or after a chemical injection of the bath but before the low water level is reached, the injector will turn off and the hot and the cold water valves to the tub will turn on until the low water level is reached or for 30 seconds, whichever comes first. Then the drain will open and proceed to the next step after the "open drain" step is completed.

If advancing before a chemical injection of the bath, the drain will open immediately and the cycle will proceed to the next step when the "open drain" step is completed.

If advancing during a spin, the tumbler will begin to decelerate immediately. However the cycle may proceed to the next bath before the tumbler comes to a complete stop. The cycle cannot be advanced further while the tumbler is decelerating.

If a temperature PCB is installed in the I/O PCB and the temperature programmed from 20 to 90 (Celsius), advancing will turn off the heater relay or steam valve immediately, if either is on, and open the drain after a three second delay. If the display shows a water temperature from 65 to 90 (may be displayed by pressing the "DOWN" and "START" buttons together), the drain will close again when the washer indicates empty and the hot and the cold water valves to the tub will turn on until the low water level is reached. The cycle will then continue to the next bath, or if programmed, to the spin of the current bath.

To exit the Rapid Advance mode during the cycle, turn the key to Run. The cycle will continue normally.

Notes:

- The cycle cannot be advanced during the "open drain" step of the bathes.
- The cycle cannot be advanced when the hot and cold water valves to the tub are on after advancing during or after a chemical injection.
- The cycle cannot be advanced again while the hot and cold water valves to the tub are on after advancing when the water temperature was 65 to 90.
- The Rapid Advance mode may only be entered after a cycle is started.
- The indicator lights will show to which segment the cycle has been advanced.
- The Rapid Advance mode cannot skip the final three tumbles of the cycle. The door lock may remain activated for a couple minutes after the cycle has been completed.
- The chemical injection signals will not turn on if the Rapid Advance mode is entered before the injection.

To end the cycle without waiting for the time to count down, push and hold the "STOP" button for 5 seconds or more. The display will then show the cycle number and be ready to start the cycle.

**OPL 40 POUND WASHER
COMPUTER CONTROLLED
PRESET CYCLE INFORMATION**

<u>APPLICATION</u>	<u>CYCLE #</u>	<u>DESCRIPTION</u>	
Shirt/Laundry	1	Shirts (No Starch)	
	2	Shirts (Starch)	
Hotel/Motel	3	White Sheets	
	4	White Pillowcases	
	5	White Towels, Bath Mats, Wash Cloths	
	6	Colored Sheets & Towels	
	7	Delicate Wash	
	8	Housekeeping Rags & Mops	
	9	Housekeeping Uniforms	
	10	Stain Treatment	
	11	Reclaim Part 1	
	12	Part 2	
	Health Care	13	Sheets & Pillowcases
		14	Towels
15		Diapers & Pads	
16		Personals	
17		Delicate	
Food & Beverage	18	White (Cotton/Blend) Table Linen	
	19	Colored (Cotton/Blend) Table Linen	
	20	White 100 % Polyester Table Linen	
	21	Colored 100 % Polyester Table Linen	
	22	White Chef Coats	
	23	Kitchen and Maintenance Rags	
	24	White/Colored (Cotton/Blend) Table Linen	
	25	White/Colored 100 % Polyester Table Linen	
	26	White Chef Coats	
	27	Kitchen and Maintenance Rags	
Other	28	Oxygen Bleach - Terry	
	29	Oxygen Bleach - Terry (No iron)	
	30	Open	
Test	31	Test Diagnostic	

CYCLE 1
 Shirt/Laundry
 Shirts (No Starch)

<u>Segment</u>	<u>Cycle Time</u>	<u>Water Temp</u>	<u>Water Level</u>	<u>Inject Source</u>	<u>Spin Time</u>
Flush					
Prewash					
Wash	12	HH	LO	Detergent/Bleach ¹	
Rinse 1	2	CH	HI		
Rinse 2	2	CH	HI		
Rinse 3	2	CH	HI		
Rinse 4					
Rinse 5					
Final	4	CH	LO		3

Total Time: 25 minutes excluding the tub fill time.

Notes: 1. Use only oxygen bleach in shirt laundries.
 DO NOT USE CHLORINE BLEACH.

CYCLE 2
 Shirt/Laundry
 Shirts (Starch)

<u>Segment</u>	<u>Cycle Time</u>	<u>Water Temp</u>	<u>Water Level</u>	<u>Inject Source</u>	<u>Spin Time</u>
Flush					
Prewash					
Wash	12	HH	LO	Detergent/Bleach ¹	
Rinse 1	2	CH	HI		
Rinse 2	2	CH	HI		
Rinse 3	2	CH	HI		
Rinse 4					
Rinse 5					
Final	7	CH	LO	Starch	3

Total Time: 28 minutes excluding the tub fill time.

Notes: 1. Use only oxygen bleach in shirt laundries.
 DO NOT USE CHLORINE BLEACH.

CYCLE 3
Hotel/Motel
White Sheets

<u>Segment</u>	<u>Cycle Time</u>	<u>Water Temp</u>	<u>Water Level</u>	<u>Inject Source</u>	<u>Spin Time</u>
Flush					
Prewash	7	HH	LO	Detergent	
Wash	7	HH	LO	Bleach	
Rinse 1	2	CH	HI		1
Rinse 2	2	CH	HI		
Rinse 3					
Rinse 4					
Rinse 5					
Final	4	CH	LO	Sour/Soft	4

Total Time: 27 minutes excluding the tub fill time.

Notes:

CYCLE 4
Hotel/Motel
White Pillowcases

<u>Segment</u>	<u>Cycle Time</u>	<u>Water Temp</u>	<u>Water Level</u>	<u>Inject Source</u>	<u>Spin Time</u>
Flush	7	HH	LO	Detergent	
Prewash	1	HH	HI		
Wash	7	HH	LO	Bleach	
Rinse 1	2	CH	HI		1
Rinse 2	2	CH	HI		
Rinse 3					
Rinse 4					
Rinse 5					
Final	4	CH	LO	Sour/Soft	4

Total Time: 28 minutes excluding the tub fill time.

Notes:

CYCLE 5
Hotel/Motel
White Towels

<u>Segment</u>	<u>Cycle Time</u>	<u>Water Temp</u>	<u>Water Level</u>	<u>Inject Source</u>	<u>Spin Time</u>
Flush	7	HH	LO	Detergent	
Prewash	1	HH	HI		
Wash	7	HH	LO	Bleach	
Rinse 1	2	CH	HI		1
Rinse 2	2	CH	HI		
Rinse 3					
Rinse 4					
Rinse 5					
Final	4	CH	LO	Sour/Soft	5

Total Time: 29 minutes excluding the tub fill time.

Notes:

CYCLE 6
Hotel/Motel
Color Sheets

<u>Segment</u>	<u>Cycle Time</u>	<u>Water Temp</u>	<u>Water Level</u>	<u>Inject Source</u>	<u>Spin Time</u>
Flush					
Prewash					
Wash	7	HH	LO	Detergent/Bleach	
Rinse 1	2	HH	HI		
Rinse 2	2	CH	HI		1
Rinse 3	2	CH	HI		
Rinse 4					
Rinse 5					
Final	4	CH	LO	Sour/Soft	4

Total Time: 22 minutes excluding the tub fill time.

Notes:

CYCLE 7
Hotel/Motel
Delicate

<u>Segment</u>	<u>Cycle Time</u>	<u>Water Temp</u>	<u>Water Level</u>	<u>Inject Source</u>	<u>Spin Time</u>
Flush					
Prewash					
Wash	8	CH	HI	Detergent/Bleach	
Rinse 1	2	HH	HI		
Rinse 2	2	CH	HI		
Rinse 3	2	CH	HI		
Rinse 4					
Rinse 5					
Final	4	CH	LO	Sour/Soft	4

Total Time: 22 minutes excluding the tub fill time.

Notes:

CYCLE 8
Hotel/Motel
Rags & Mops

<u>Segment</u>	<u>Cycle Time</u>	<u>Water Temp</u>	<u>Water Level</u>	<u>Inject Source</u>	<u>Spin Time</u>
Flush	3	CH	HI		
Prewash	2	CH	HI		
Wash	2	CH	HI		
Rinse 1	2	CH	HI		
Rinse 2	7	HH	LO	Detergent	
Rinse 3	2	HH	HI		
Rinse 4	7	HH	LO	Bleach	
Rinse 5	2	CH	HI		1
Final	2	CH	HI		5

Total Time: 35 minutes excluding the tub fill time.

Notes:

CYCLE 9
Hotel/Motel
Uniforms

<u>Segment</u>	<u>Cycle Time</u>	<u>Water Temp</u>	<u>Water Level</u>	<u>Inject Source</u>	<u>Spin Time</u>
Flush	2	CH	HI		
Prewash					
Wash	7	HH	LO	Detergent	
Rinse 1	7	HH	LO	Bleach	
Rinse 2	2	CH	HI		1
Rinse 3	2	CH	HI		
Rinse 4					
Rinse 5					
Final	4	CH	LO	Sour/Soft	4

Total Time: 29 minutes excluding the tub fill time.

Notes:

CYCLE 10
Hotel/Motel
Stain Treatment - Chlorine Bleach

<u>Segment</u>	<u>Cycle Time</u>	<u>Water Temp</u>	<u>Water Level</u>	<u>Inject Source</u>	<u>Spin Time</u>
Flush					
Prewash					
Wash	30	HH	LO	Detergent/Bleach	
Rinse 1	2	HH	HI		
Rinse 2	2	HH	HI		
Rinse 3	2	CH	HI		1
Rinse 4					
Rinse 5					
Final	2	CH	HI		4

Total Time: 43 minutes excluding the tub fill time.

Notes:

CYCLE 11
Hotel/Motel
Reclaim (Part 1)

<u>Segment</u>	<u>Cycle Time</u>	<u>Water Temp</u>	<u>Water Level</u>	<u>Inject Source</u>	<u>Spin Time</u>
Flush					
Prewash					
Wash	20	HH	LO	Manual	
Rinse 1	3	HH	HI		
Rinse 2					
Rinse 3					
Rinse 4					
Rinse 5					
Final	3	HH	HI		1

Total Time: 27 minutes excluding the tub fill time.

Notes:

CYCLE 12
Hotel/Motel
Reclaim (Part 2)

<u>Segment</u>	<u>Cycle Time</u>	<u>Water Temp</u>	<u>Water Level</u>	<u>Inject Source</u>	<u>Spin Time</u>
Flush					
Prewash	3	HH	HI		
Wash	20	HH	LO	Manual	
Rinse 1	3	HH	HI		
Rinse 2	3	HH	HI		
Rinse 3	10	HH	LO	Bleach	
Rinse 4	3	HH	HI		1
Rinse 5					
Final	3	CH	HI		4

Total Time: 50 minutes excluding the tub fill time.

Notes:

CYCLE 13
Health Care
Sheets & Pillowcases

<u>Segment</u>	<u>Cycle Time</u>	<u>Water Temp</u>	<u>Water Level</u>	<u>Inject Source</u>	<u>Spin Time</u>
Flush	3	CH	HI		
Prewash	2	CH	HI		
Wash	7	HH	LO	Detergent	
Rinse 1	7	HH	LO	Bleach	
Rinse 2	2	CH	HI		1
Rinse 3	2	CH	HI		
Rinse 4					
Rinse 5					
Final	4	CH	LO	Sour/Soft	4

Total Time: 32 minutes excluding the tub fill time.

Notes:

CYCLE 14
Health Care
Towels

<u>Segment</u>	<u>Cycle Time</u>	<u>Water Temp</u>	<u>Water Level</u>	<u>Inject Source</u>	<u>Spin Time</u>
Flush	3	CH	HI		
Prewash	2	CH	HI		
Wash	7	HH	LO	Detergent	
Rinse 1	1	HH	HI		
Rinse 2	7	HH	LO	Bleach	
Rinse 3	2	CH	HI		1
Rinse 4	2	CH	HI		
Rinse 5					
Final	4	CH	LO	Sour/Soft	5

Total Time: 34 minutes excluding the tub fill time.

Notes:

CYCLE 15
Health Care
Diapers

<u>Segment</u>	<u>Cycle Time</u>	<u>Water Temp</u>	<u>Water Level</u>	<u>Inject Source</u>	<u>Spin Time</u>
Flush	3	CH	HI		
Prewash	2	CH	HI		
Wash	2	CH	HI		
Rinse 1	7	HH	LO	Detergent	
Rinse 2	2	HH	HI		
Rinse 3	7	HH	LO	Bleach	
Rinse 4	2	CH	HI		1
Rinse 5	2	CH	HI		
Final	4	CH	LO	Sour/Soft	4

Total Time: 36 minutes excluding the tub fill time.

Notes:

CYCLE 16
Health Care
Personals

<u>Segment</u>	<u>Cycle Time</u>	<u>Water Temp</u>	<u>Water Level</u>	<u>Inject Source</u>	<u>Spin Time</u>
Flush	3	CH	HI		
Prewash					
Wash	7	HH	LO	Detergent/Bleach	
Rinse 1	2	HH	HI		
Rinse 2	2	CH	HI		
Rinse 3	2	CH	HI		
Rinse 4					
Rinse 5					
Final	4	CH	LO	Sour/Soft	4

Total Time: 24 minutes excluding the tub fill time.

Notes:

CYCLE 17
Health Care
Delicate

<u>Segment</u>	<u>Cycle Time</u>	<u>Water Temp</u>	<u>Water Level</u>	<u>Inject Source</u>	<u>Spin Time</u>
Flush	2	CH	HI		
Prewash					
Wash	7	CH	HI	Detergent/Bleach	
Rinse 1	2	CH	HI		
Rinse 2	2	CH	HI		
Rinse 3	2	CH	HI		
Rinse 4					
Rinse 5					
Final	4	CH	HI	Sour/Soft	3

Total Time: 22 minutes excluding the tub fill time.

Notes:

CYCLE 18
Food & Beverage
White Cotton Linen

<u>Segment</u>	<u>Cycle Time</u>	<u>Water Temp</u>	<u>Water Level</u>	<u>Inject Source</u>	<u>Spin Time</u>
Flush	2	CH	HI		
Prewash					
Wash	10	HH	LO	Detergent	
Rinse 1	2	HH	HI		
Rinse 2	7	HH	LO	Bleach	
Rinse 3	2	CH	HI		1
Rinse 4	2	CH	HI		
Rinse 5					
Final	4	CH	LO	Sour/Starch	4

Total Time: 34 minutes excluding the tub fill time.

Notes:

CYCLE 19
Food & Beverage
Colored Cotton Linen

<u>Segment</u>	<u>Cycle Time</u>	<u>Water Temp</u>	<u>Water Level</u>	<u>Inject Source</u>	<u>Spin Time</u>
Flush	2	CH	HI		
Prewash					
Wash	10	HH	LO	Detergent	
Rinse 1	7	HH	LO	Bleach	
Rinse 2	2	CH	HI		1
Rinse 3	2	CH	HI		
Rinse 4					
Rinse 5					
Final	4	CH	LO	Sour/Starch	4

Total Time: 32 minutes excluding the tub fill time.

Notes:

CYCLE 20
Food & Beverage
White 100 % Polyester Linen

<u>Segment</u>	<u>Cycle Time</u>	<u>Water Temp</u>	<u>Water Level</u>	<u>Inject Source</u>	<u>Spin Time</u>
Flush	2	CH	HI		
Prewash					
Wash	10	HH	LO	Detergent	
Rinse 1	2	HH	HI		
Rinse 2	7	HH	LO	Bleach	
Rinse 3	2	CH	HI		
Rinse 4	2	CH	HI		
Rinse 5					
Final	4	CH	LO	Sour/Starch	4

Total Time: 33 minutes excluding the tub fill time.

Notes:

CYCLE 21
Food & Beverage
Colored 100 % Polyester Linen

<u>Segment</u>	<u>Cycle Time</u>	<u>Water Temp</u>	<u>Water Level</u>	<u>Inject Source</u>	<u>Spin Time</u>
Flush	2	CH	HI		
Prewash					
Wash	10	HH	LO	Detergent	
Rinse 1	7	HH	LO	Bleach	
Rinse 2	2	CH	HI		1
Rinse 3	2	CH	HI		
Rinse 4					
Rinse 5					
Final	4	CH	LO	Sour/Starch	4

Total Time: 32 minutes excluding the tub fill time.

Notes:

CYCLE 22
Food & Beverage
White Chef Coats

<u>Segment</u>	<u>Cycle Time</u>	<u>Water Temp</u>	<u>Water Level</u>	<u>Inject Source</u>	<u>Spin Time</u>
Flush	5	HH	LO	Detergent	
Prewash	1	HH	HI		
Wash	8	HH	LO	Detergent	
Rinse 1	2	HH	HI		
Rinse 2	7	HH	LO	Bleach	
Rinse 3	2	CH	HI		1
Rinse 4	2	CH	HI		
Rinse 5					
Final	4	CH	LO	Sour	4

Total Time: 36 minutes excluding the tub fill time.

Notes:

CYCLE 23
Food & Beverage
Kitchen Rags

<u>Segment</u>	<u>Cycle Time</u>	<u>Water Temp</u>	<u>Water Level</u>	<u>Inject Source</u>	<u>Spin Time</u>
Flush	5	HH	LO	Detergent	
Prewash	2	HH	HI		
Wash	8	HH	LO	Detergent	
Rinse 1	2	HH	HI		1
Rinse 2	7	HH	LO	Bleach	
Rinse 3	2	CH	HI		1
Rinse 4					
Rinse 5					
Final	2	CH	HI		5

Total Time: 35 minutes excluding the tub fill time.

Notes:

CYCLE 24
Food & Beverage
White/Colored (Cotton/Blend) Linen

<u>Segment</u>	<u>Cycle Time</u>	<u>Water Temp</u>	<u>Water Level</u>	<u>Inject Source</u>	<u>Spin Time</u>
Flush	2	CH	HI		
Prewash					
Wash	10	HH	LO	Detergent/Bleach	
Rinse 1	1	HH	HI		
Rinse 2	2	HH	HI		1
Rinse 3	2	CH	HI		
Rinse 4	2	CH	HI		
Rinse 5					
Final	4	CH	LO	Sour/Starch	4

Total Time: 28 minutes excluding the tub fill time.

Notes:

CYCLE 25
 Food & Beverage
 White/Colored 100 % Polyester Linen

<u>Segment</u>	<u>Cycle Time</u>	<u>Water Temp</u>	<u>Water Level</u>	<u>Inject Source</u>	<u>Spin Time</u>
Flush	2	CH	HI		
Prewash					
Wash	10	HH	LO	Detergent/Bleach	
Rinse 1	1	HH	HI		
Rinse 2	2	HH	LO		
Rinse 3	2	CH	HI		
Rinse 4	2	CH	HI		
Rinse 5					
Final	4	CH	LO	Sour/Starch	4

Total Time: 27 minutes excluding the tub fill time.

Notes:

CYCLE 26
 Food & Beverage
 White Chef Coats

<u>Segment</u>	<u>Cycle Time</u>	<u>Water Temp</u>	<u>Water Level</u>	<u>Inject Source</u>	<u>Spin Time</u>
Flush	5	HH	LO	Detergent	
Prewash	1	HH	HI		
Wash	10	HH	LO	Detergent/Bleach	
Rinse 1	2	HH	HI		
Rinse 2	2	CH	HI		1
Rinse 3	2	CH	HI		
Rinse 4					
Rinse 5					
Final	4	CH	HI	Sour/Soft	4

Total Time: 31 minutes excluding the tub fill time.

Notes:

CYCLE 27
Food & Beverage
Kitchen Rags

<u>Segment</u>	<u>Cycle Time</u>	<u>Water Temp</u>	<u>Water Level</u>	<u>Inject Source</u>	<u>Spin Time</u>
Flush	5	HH	LO	Detergent	
Prewash	2	HH	HI		
Wash	10	HH	LO	Detergent/Bleach	
Rinse 1	1	HH	HI		
Rinse 2	2	HH	HI		1
Rinse 3	2	CH	HI		
Rinse 4					
Rinse 5					
Final	2	CH	HI		5

Total Time: 30 minutes excluding the tub fill time.

Notes:

CYCLE 28
Other
Oxygen Bleach Terry

<u>Segment</u>	<u>Cycle Time</u>	<u>Water Temp</u>	<u>Water Level</u>	<u>Inject Source</u>	<u>Spin Time</u>
Flush	3	CH	HI		
Prewash	2	CH	HI		
Wash	10	HH	LO	Detergent/Bleach	
Rinse 1	2	HH	HI		
Rinse 2	2	CH	HI		1
Rinse 3	2	CH	HI		
Rinse 4					
Rinse 5					
Final	4	CH	LO	Sour/Soft	3

Total Time: 29 minutes excluding the tub fill time.

Notes:

CYCLE 29
Other
Oxygen Bleach Terry (No Iron)

<u>Segment</u>	<u>Cycle Time</u>	<u>Water Temp</u>	<u>Water Level</u>	<u>Inject Source</u>	<u>Spin Time</u>
Flush	3	CH	HI		
Prewash	2	CH	HI		
Wash	10	HH	LO	Detergent/Bleach	
Rinse 1	2	HH	HI		
Rinse 2	2	CH	HI		1
Rinse 3	2	CH	HI		
Rinse 4					
Rinse 5					
Final	4	CH	LO	Sour/Soft	5

Total Time: 31 minutes excluding the tub fill time.

Notes:

CYCLE 30

<u>Segment</u>	<u>Cycle Time</u>	<u>Water Temp</u>	<u>Water Level</u>	<u>Inject Source</u>	<u>Spin Time</u>
Flush					
Prewash					
Wash					
Rinse 1					
Rinse 2					
Rinse 3					
Rinse 4					
Rinse 5					
Final					

Total Time:

Notes:

CYCLE

<u>Segment</u>	<u>Cycle Time</u>	<u>Water Temp</u>	<u>Water Level</u>	<u>Inject Source</u>	<u>Spin Time</u>
Flush					
Prewash					
Wash					
Rinse 1					
Rinse 2					
Rinse 3					
Rinse 4					
Rinse 5					
Final					

Total Time:

Notes:

CYCLE

<u>Segment</u>	<u>Cycle Time</u>	<u>Water Temp</u>	<u>Water Level</u>	<u>Inject Source</u>	<u>Spin Time</u>
Flush					
Prewash					
Wash					
Rinse 1					
Rinse 2					
Rinse 3					
Rinse 4					
Rinse 5					
Final					

Total Time:

Notes:

© 2010, Dexter Laundry, Inc.

2211 West Grimes, Fairfield, IA 52556 U.S.A.

1-800-524-2954

www.dexterlaundry.com