



***DEXTER***<sup>®</sup>  
***LAUNDRY***



## DDAD T-30X2 Models 30 Pound Stacked Commercial Dryer Troubleshooting, Fault codes, And Schematics

---

# Trouble Shooting

## Electronic Control Diagnostic Lights

The electronic control has 6 diagnostic lights to aid in service of the dryer. Each pocket has indicator lights for the motor circuit, door switch circuit, and the heat circuit. When the electronic control is carefully unlocked and moved forward these lights are visible on the circuit board. They are each labeled as to function indicated.

1. When either dryer door is closed, the appropriate door light on the computer should be illuminated indicating that the door is closed.
2. When either dryer is running, the appropriate motor light on the computer should be illuminated indicating that the computer is calling for the motor to operate.
3. When either dryer is calling for heat, the appropriate heat light on the computer should be illuminated indicating that the computer is calling for heat.

An example of their function would be troubleshooting an upper dryer pocket that did not heat.

1. Start the machine and insure that it did not heat.
2. Check the upper heat light and see if it is lit.
3. If the heat light is on, this would indicate that the computer was calling for heat and that it was not at fault. You would then go on to check the rest of the heat circuit.

## Electronic Control Test Cycle

This test cycle allows the dryer to run for 5 minutes without the need for adding money while servicing. To actuate this 5 minute test cycle leave the loading doors closed, unlock the computer and push the program button on the right front corner of the computer as if you were putting it into the program mode. This will give a 5 minute cycle on both tumblers for evaluating the machine.

# Trouble Shooting Fault Codes

- F1 Shorted sensor or shorted sensor wire harness
- F2 Open sensor or sensor wire harness disconnected
- F3 Possible grounding problem. Try powering down and repowering and then push programming button to start dryer. Try resetting with Palm Pilot (extra utilities file). If no success. Try removing battery and reinstall battery.
- F4 Micro Chip Problem. Replace controller.
- F5 Microchip Electrical Problem. Remove power for 1 minute and then power on. Try removing battery and reinstalling on control PCB/

## TROUBLESHOOTING TIPS

Symptom	Probable Cause	Suggested Remedy
Tumbler does not turn	Drive belts	Check both drive belts. Replace if failed.
	Drive motor	Check capacitor and motor. Replace if failed
	Door switch	Check door switch contacts and adjustment. Adjust or replace door switch.
	Electronic Control	Is electronic control closing motor relay to power drive motor? Check for motor light on electronic control. If no light change control. If light is on, check voltage and wiring to motor.

Symptom	Probable Cause	Suggested Remedy
Tumbler turns but no spark at burner	Glass fuse	Check small glass control fuse in back of dryer. Replace if failed.
	Temperature Sensor	The temperature sensor should have between 30,000 ohms and 60,000 ohms resistance at room temperature if okay. Replace if not in this range.
	Ignition	Check for 24VAC output from transformer.
	Transformer	Replace if have 120V between black & white and no 24V between red and yellow.
	Over temperature	Check to see if manually resettable thermostat. Thermostat is kicked out. Reset by pushing red reset button.
	Ignition control	Check for 24VAC coming into the control on the at burner red wire. If voltage, then check for 24VAC out on the brown wire. Also check for spark at the ignitor. If no 24VAC output or no spark to the ignitor, replace ignition control.
	Air Flow Switch	Check air flow switch to be sure it closes when dryer is running. If not, adjust or replace switch.
	Hi-limit	Check for continuity. Should be 0 ohms resistance when cold. If not, replace thermostat.
	Gas supply	No gas can cause system lockout
	Electronic Control	Is electronic control closing gas relay to power Control heat circuit? Check for gas light on electronic control. If no light change control. If light is on, check voltage and components in heat circuit at transformer at rear of unit.

Symptom	Probable Cause	Suggested Remedy
Tumbler turns, ignition sparks, no flame	Gas supply	Make sure gas supply is working.
	Gas pressure	Make manometer check of gas pressure. Adjust if necessary.
	Spark Electrode Sensor	Check for damage to electrode or mounting. Replace if necessary.
	Gas valve	Check coil continuity, replace valve if failed.
	Ignition Control	Check for 24VAC to gas valve coils. If no voltage replace ignition control.
Burner Lights, but goes on and off	Electrodes	Check low voltage harness for possible wire break or cuts to allow no signal back to ignition control
Slow drying	Temperature Setting	Check program for correct high temperature setting. Adjust if necessary.
	Air flow restrictions necessary	<ol style="list-style-type: none"> <li>1. Check lint screen and clean if necessary.</li> <li>2. Check exhaust for correct length and clean if necessary.</li> <li>3. Check exhaust damper to insure that it opens when dryer is running and closes when dryer is not in use.</li> <li>4. Check makeup air to insure that it is adequate. Increase makeup air if necessary.</li> <li>5. Check static Back pressure no more than .3</li> </ol>
	Temperature Sensor	The temperature sensor should have between 30,000 ohms and 60,000 ohms resistance at room temperature if okay. Replace if not in this range.

Symptom	Probable Cause	Suggested Remedy
Erratic display	Initial Start-up	If erratic on initial start-up, leave power on for approximately one hour and check machine operation again.
	Grounding	Machine must be grounded by separate conductor back to neutral bar in breaker box.
	Program	Check program and make corrections if necessary.
	Voltage spike	Power down machine for 20 seconds and repower. If no improvement, replace control.
Manual overtemp Tripping Frequently	Recirculating chamber Lint Accumulation	Remove manual overtemp thermostat and inspect in chamber for excessive lint build up. Access also gained to this chamber by removing recirculation duct mounted at bottom of chamber, or the panel inside burner chamber between burners and rear back panel
	Exhaust ducting Excessive lint buildup	Remove exhaust duct at rear of dryer and inspect for excessive lint build up in complete duct from dryer to where duct exits building.
	Clean lint of of top heat air chamber above tumbler	Remove front panel completely. Be careful of any wiring attached. Remove heated air chamber cover and clean above tumbler back to burner housing.

# Wiring Schematic for DDAD Dryer

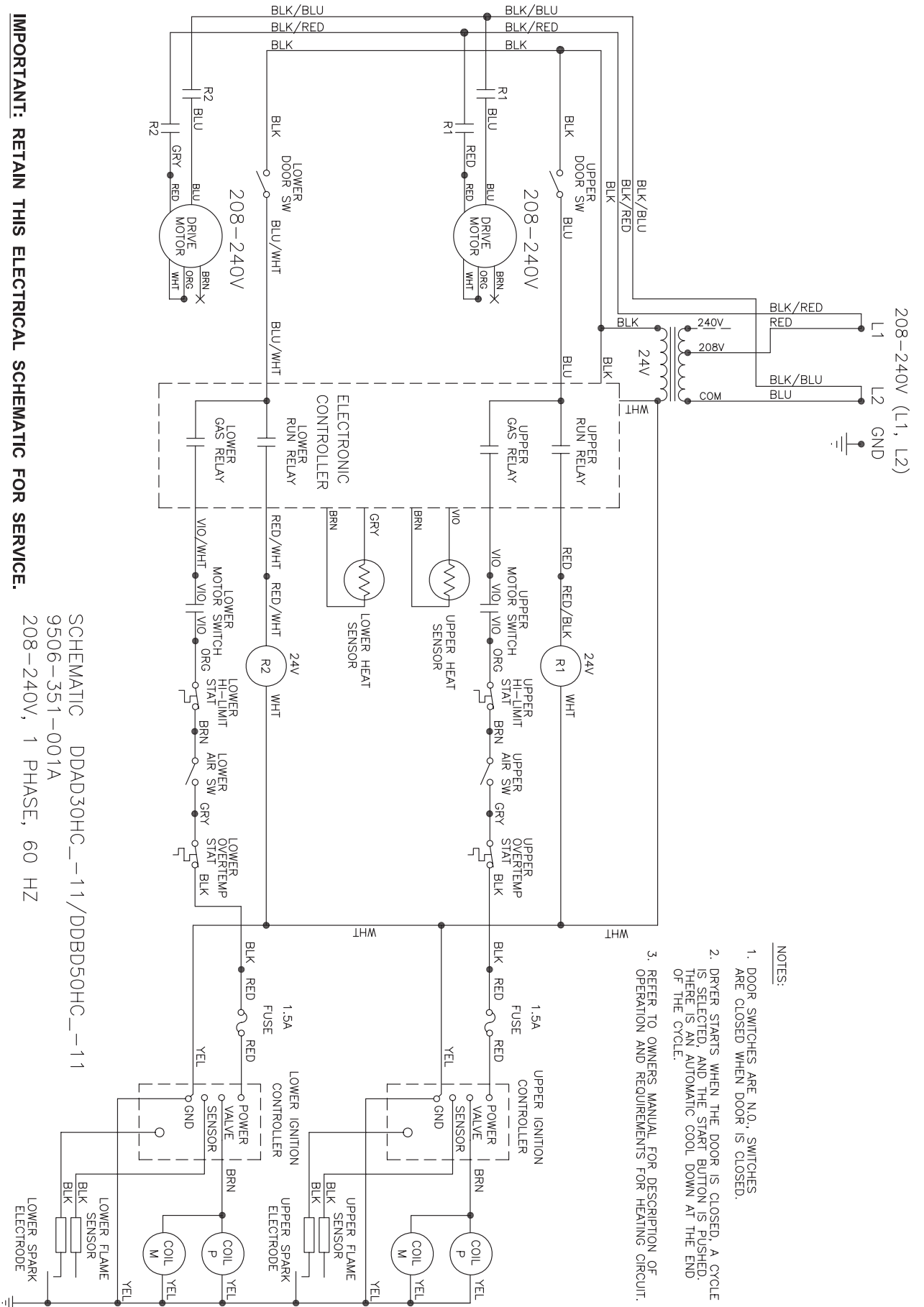

**IMPORTANT: RETAIN THIS ELECTRICAL SCHEMATIC FOR SERVICE.**

SCHMATIC DDAD30HC\_11/DDBD50HC\_11  
 9506-351-001A  
 208-240V, 1 PHASE, 60 HZ

- NOTES:**
1. DOOR SWITCHES ARE N.O. SWITCHES. ARE CLOSED WHEN DOOR IS CLOSED.
  2. DRYER STARTS WHEN THE DOOR IS CLOSED, A CYCLE IS SELECTED, AND THE START BUTTON IS PUSHED. THERE IS AN AUTOMATIC COOL DOWN AT THE END OF THE CYCLE.
  3. REFER TO OWNERS MANUAL FOR DESCRIPTION OF OPERATION AND REQUIREMENTS FOR HEATING CIRCUIT.

# Wiring Diagram for DDAD Dryer

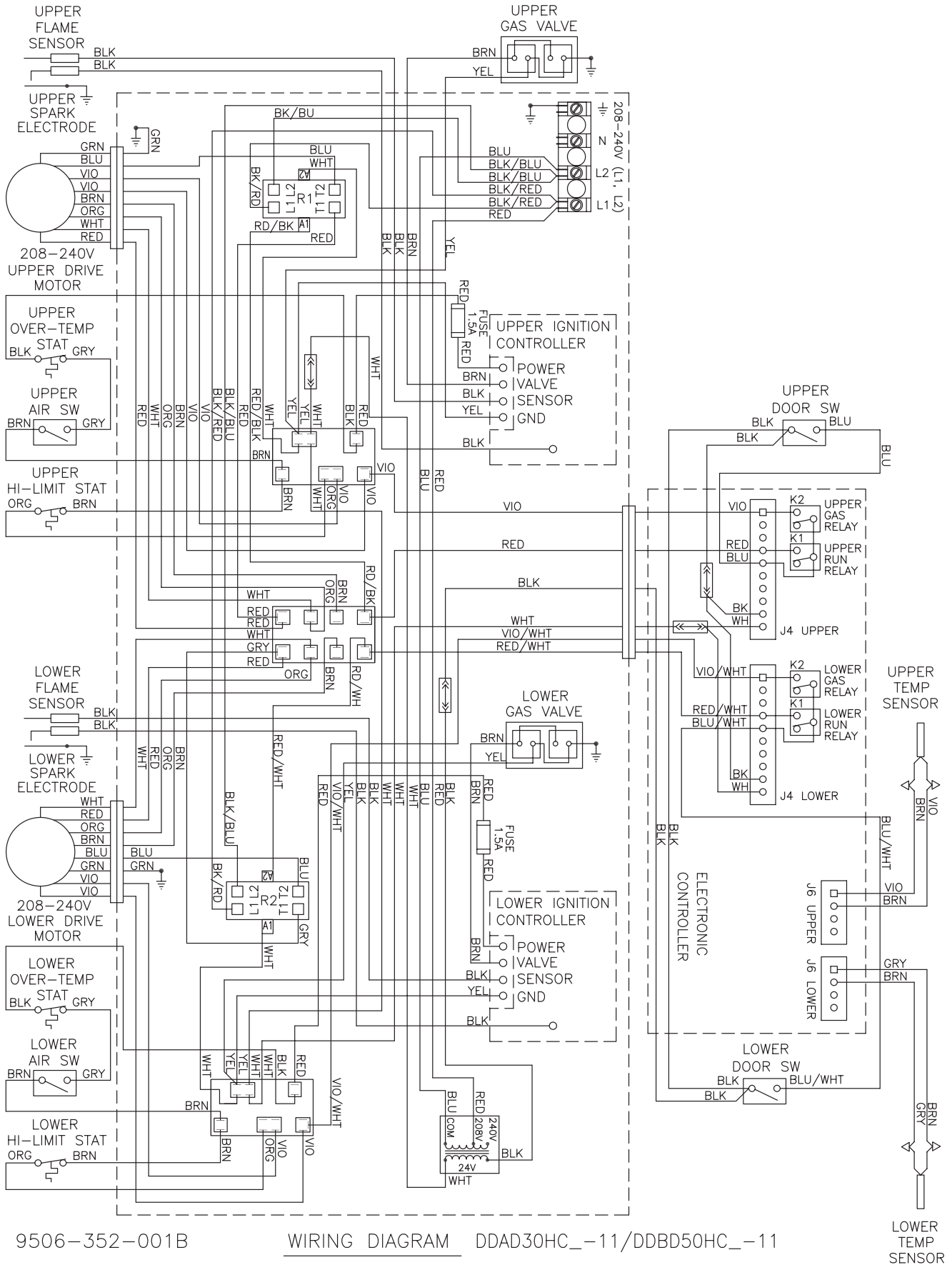



# Wiring Diagram for DDAD Dryer w/control Protection Fuse (after Serial # 211750)

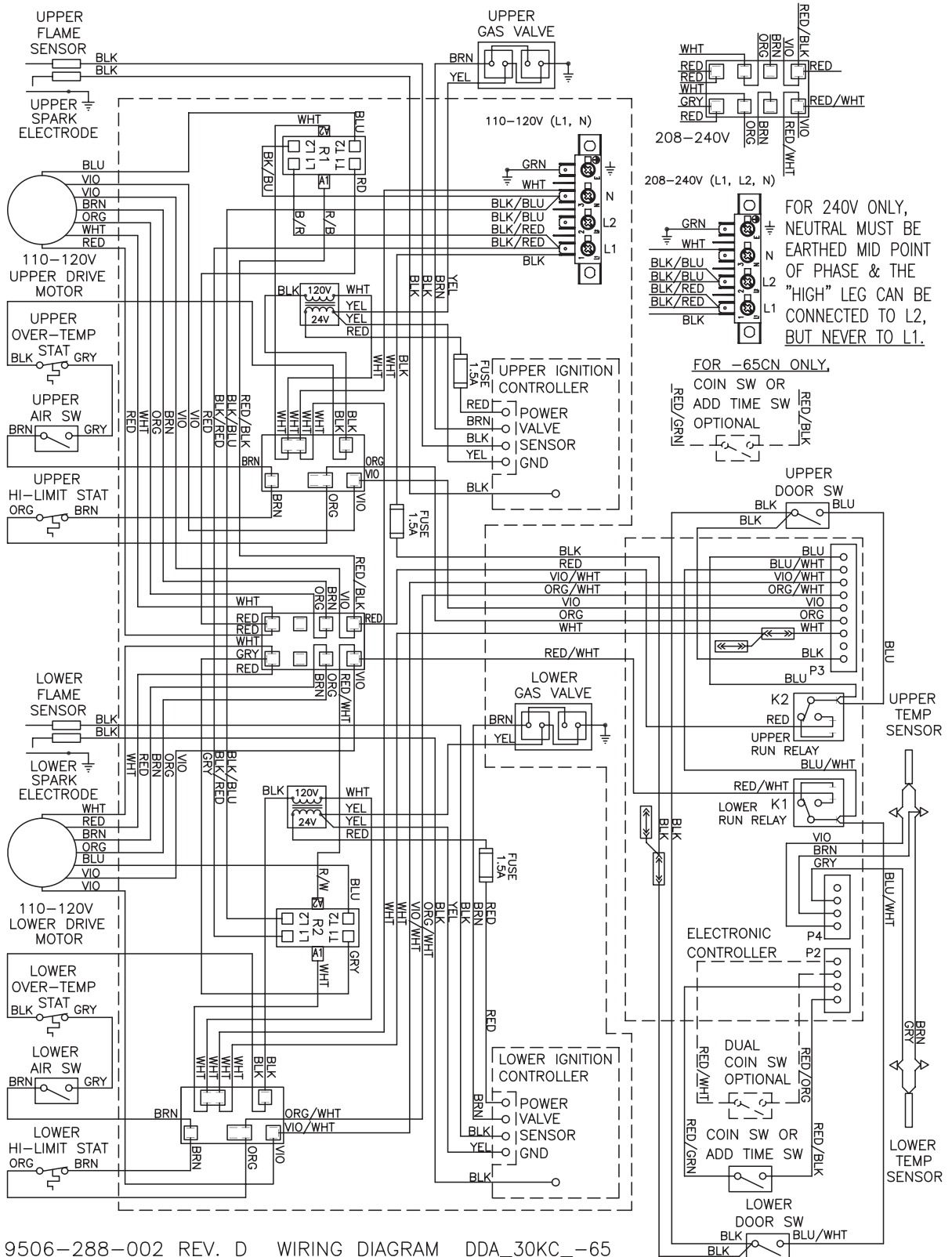

9506-288-002 REV. D WIRING DIAGRAM DDA\_30KC\_-65

**IMPORTANT: RETAIN THIS ELECTRICAL DIAGRAM FOR SERVICE.**

# Wiring Schematic for DDAD Dryer w/control Protection Fuse (after Serial # 211750)

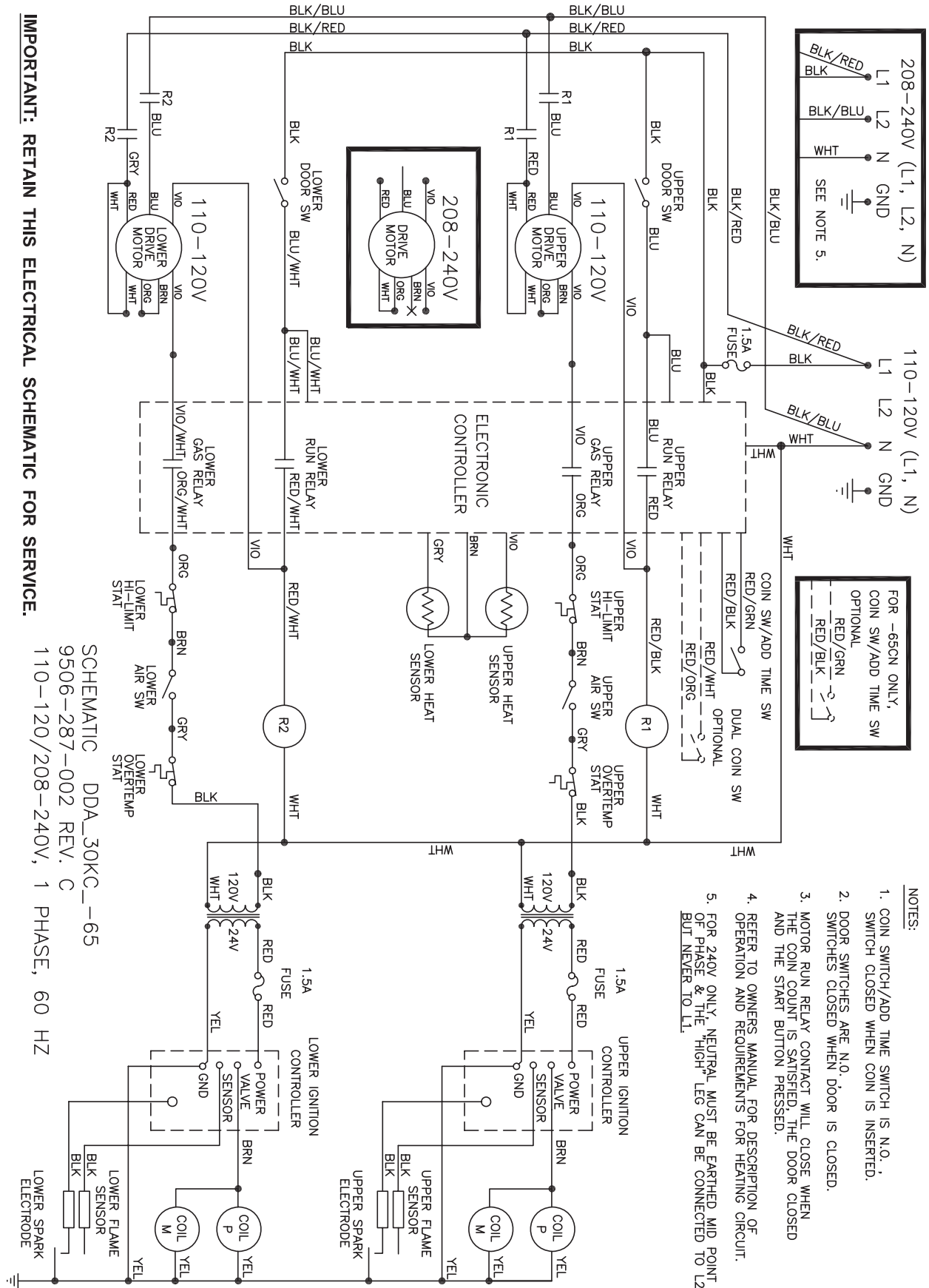

**IMPORTANT: RETAIN THIS ELECTRICAL SCHEMATIC FOR SERVICE.**

SCHEMATIC DDA\_30KC\_-65  
9506-287-002 REV. C  
110-120/208-240V, 1 PHASE, 60 HZ

- NOTES:
1. COIN SWITCH/ADD TIME SWITCH IS N.O., SWITCH CLOSED WHEN COIN IS INSERTED.
  2. DOOR SWITCHES ARE N.O. SWITCHES CLOSED WHEN DOOR IS CLOSED.
  3. MOTOR RUN RELAY CONTACT WILL CLOSE WHEN THE COIN COUNT IS SATISFIED, THE DOOR CLOSED AND THE START BUTTON PRESSED.
  4. REFER TO OWNERS MANUAL FOR DESCRIPTION OF OPERATION AND REQUIREMENTS FOR HEATING CIRCUIT.
  5. FOR 240V ONLY, NEUTRAL MUST BE EARTHED MID POINT OF PHASE & THE "HIGH" LEG CAN BE CONNECTED TO L2, BUT NEVER TO L1.

# Wiring Schematic for DDAD Dryer 50HZ

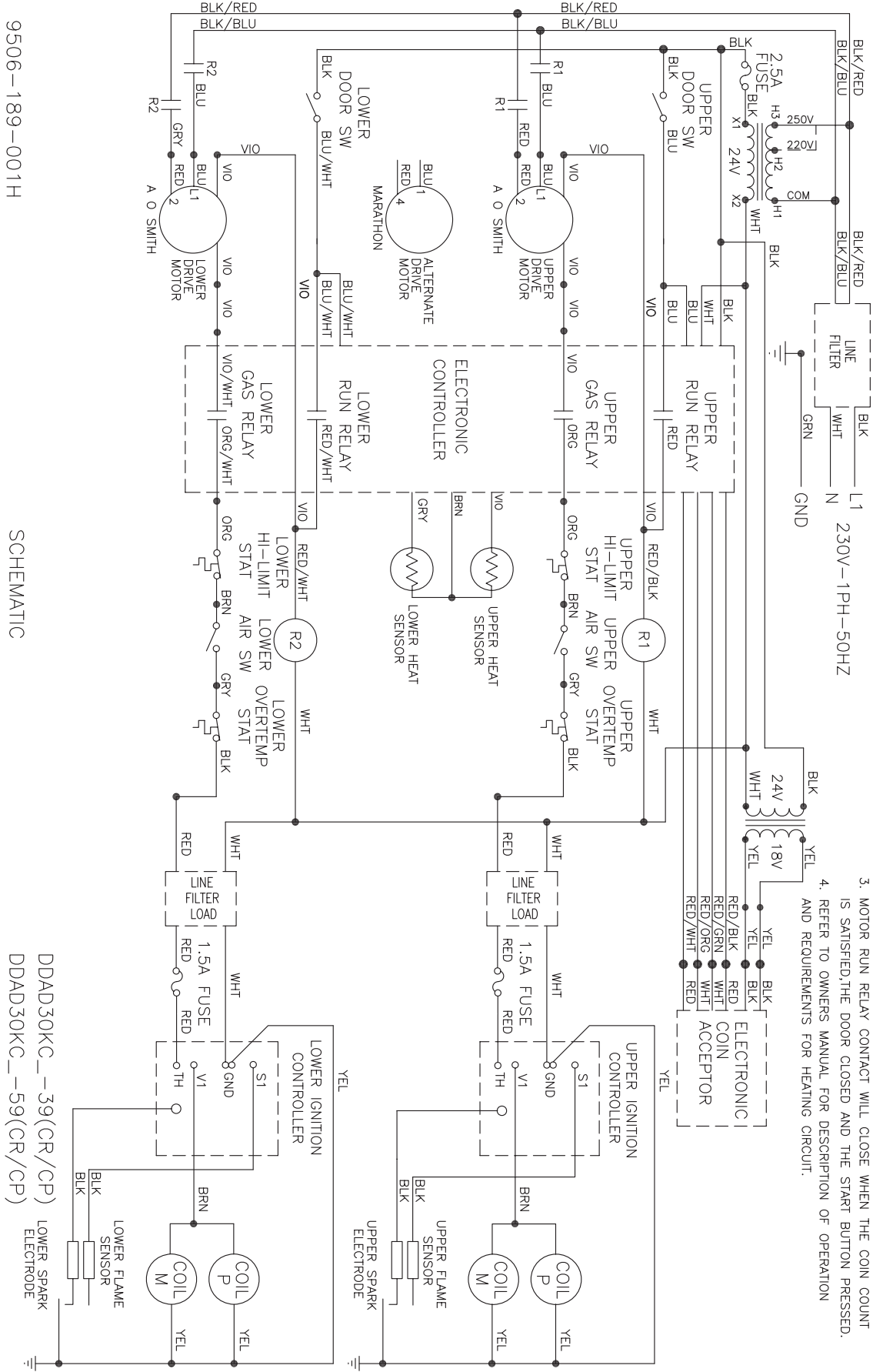

## IMPORTANT: RETAIN THIS ELECTRICAL SCHEMATIC FOR SERVICE.

- NOTES:
1. ELECTRONIC COIN ACCEPTOR-N.O., CLOSED WHEN COIN INSERTED
  2. DOOR SWITCHES-N.O., CLOSED WHEN DOOR IS CLOSED.
  3. MOTOR RUN RELAY CONTACT WILL CLOSE WHEN THE COIN COUNT IS SATISFIED, THE DOOR CLOSED AND THE START BUTTON PRESSED.
  4. REFER TO OWNERS MANUAL FOR DESCRIPTION OF OPERATION AND REQUIREMENTS FOR HEATING CIRCUIT.

9506-189-001H

SCHEMATIC

DDAD30KC\_ -39(CR/CP)  
 DDAD30KC\_ -59(CR/CP)  
 LOWER SPARK ELECTRODE

# Wiring Diagram for DDAD Dryer 50HZ

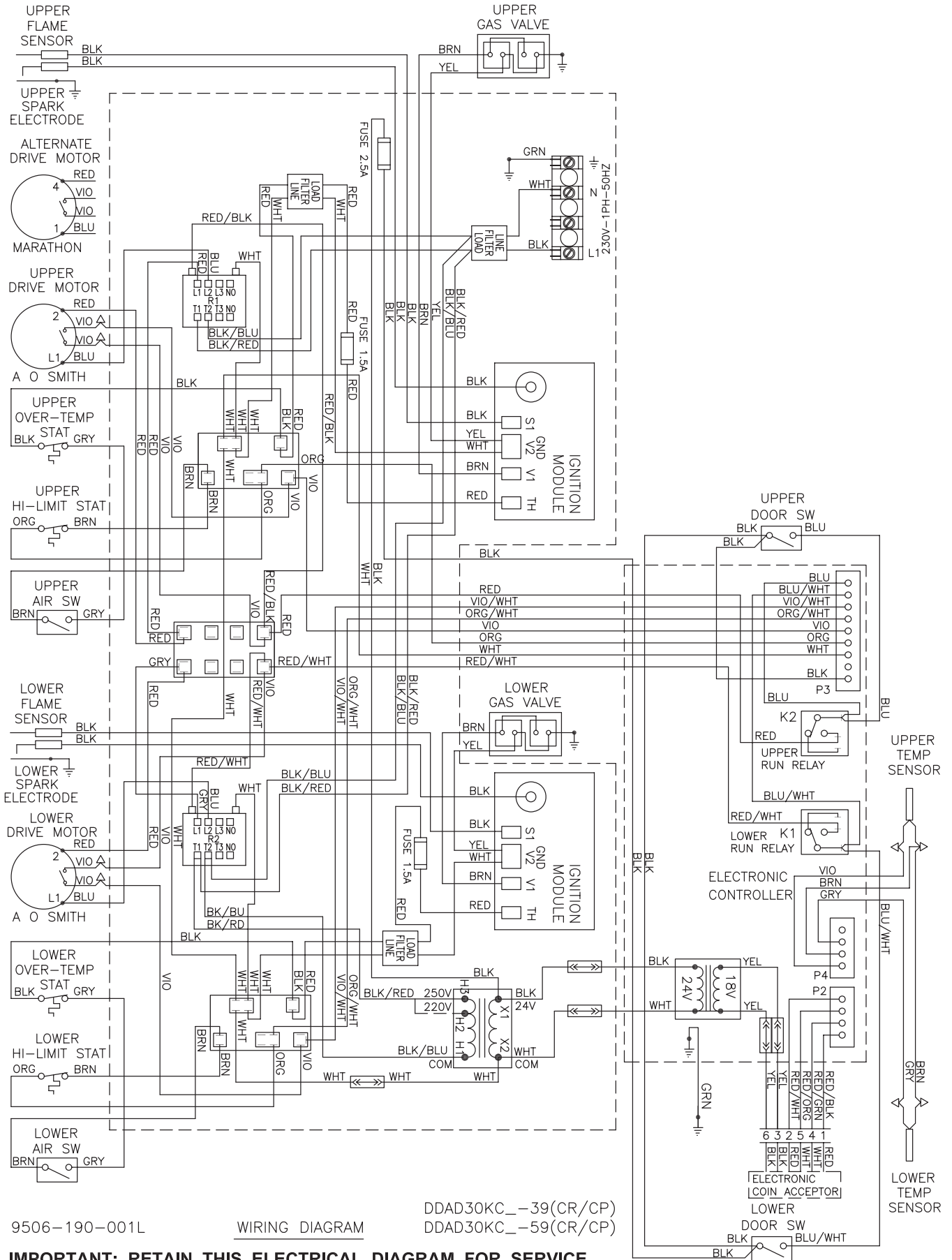

9506-190-001L

WIRING DIAGRAM

DDAD30KC\_-39(CR/CP)  
DDAD30KC\_-59(CR/CP)

**IMPORTANT: RETAIN THIS ELECTRICAL DIAGRAM FOR SERVICE.**