

**MODEL T900/950
60LB CAPACITY
COMPUTER CONTROL
COIN WASHER**

***DEXTER
LAUNDRY,
INC.***

**OWNER'S BOOKLET
INSTALLATION & OPERATION
INSTRUCTIONS**

Please read this information and retain for reference.

WARNING - THIS WASHER IS EQUIPPED WITH DEVICES AND FEATURES RELATING TO ITS SAFE OPERATION. TO AVOID INJURY OR ELECTRICAL SHOCK, DO NOT PERFORM ANY SERVICING UNLESS QUALIFIED TO DO SO.

IT IS THE RESPONSIBILITY OF THE OWNER TO CHECK THIS EQUIPMENT ON A FREQUENT BASIS TO ASSURE ITS SAFE OPERATION.

A machine should not be allowed to operate if any of the following occur:

- Excessively high water level.
- If machine is not connected to a properly grounded circuit.
- If the door does not remain securely locked during the entire cycle.
- Vibration or shaking from an inadequate mounting or foundation.

WARNING - FOR SAFETY

1. Always shut off power and water supply before servicing.
2. Do not overload the washer.
3. Do not open door when cylinder is in motion or it contains water.
4. Do not bypass any safety devices of this washer.
5. Do not use volatile or flammable substances in or near this washer.
6. Keep all panels in place. They protect against shock and injury and add rigidity to the washer.

PREVENTIVE MAINTENANCE REQUIREMENTS

DAILY

- Check that the loading door remains securely locked and cannot be opened during the entire cycle.
- Check the water connections for leaks.
- Clean the top and sides of the cabinet to remove residue.
- Clean the soap dispenser and lid and check that the lid is in-place and tight.
- Check the drain valve for leaking and that it opens properly.
- Check the loading door for leaks. Clean the door seal of all foreign matter.
- Leave the loading door open to aerate the washer when not in use.

QUARTERLY

- Make sure the washer is inoperative by switching off the main power supply.
- Check the V-belts for wear and proper tension.
- Clean lint and other foreign matter from around motor.
- Check all water connections for leaks.
- Wipe and clean the inside of the washer and check that all electrical components are free of moisture and dust.
- Remove and clean water inlet hose filters. Replace if necessary.
- Check anchor bolts - retighten if necessary

IMPORTANT: Replace any and all panels that were removed to perform daily and/or quarterly maintenance.

900/950 SERIES COMMERCIAL WASHER MOUNTING DIMENSIONS

* TOP WATER INLETS ONLY ON 950 SERIES

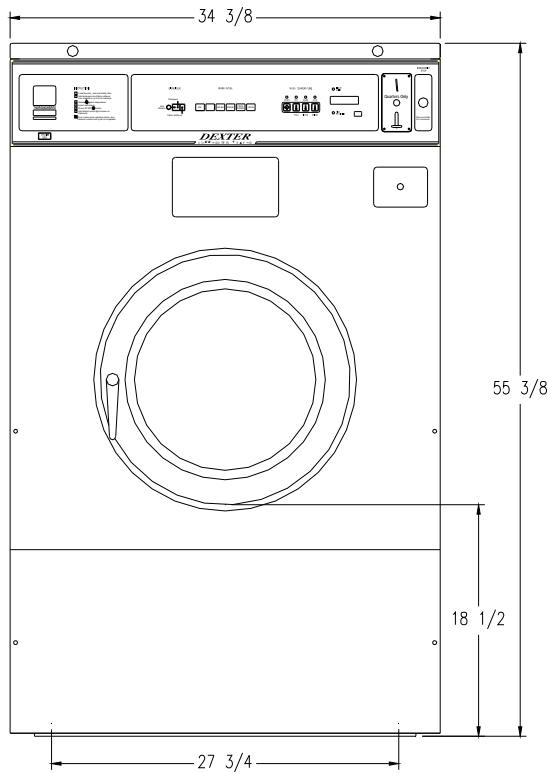

FRONT

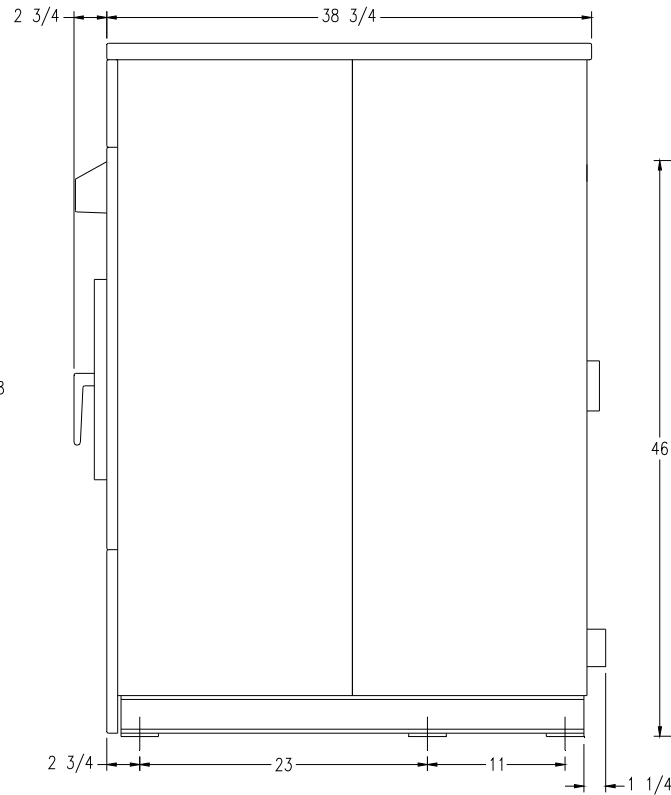

SIDE

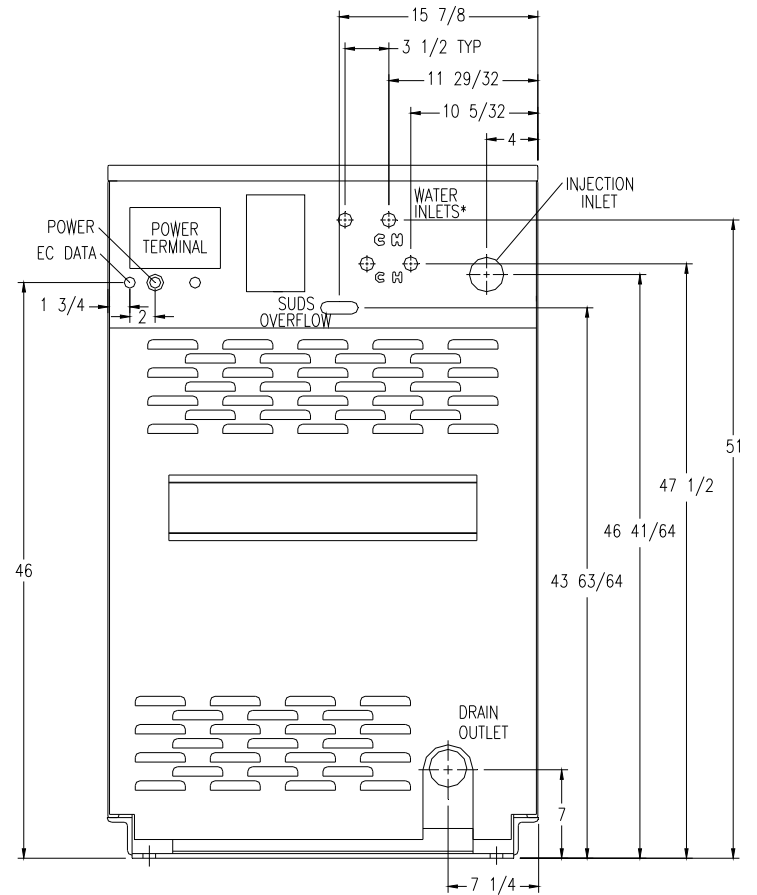

BACK

***DEXTER
LAUNDRY,
INC.***

INSTALLATION INSTRUCTIONS

All washers must be installed in accordance with all local, state and national building, electrical, plumbing and other codes in effect in the area.

WARNING - THESE INSTALLATION AND SERVICING INSTRUCTIONS ARE FOR USE BY QUALIFIED PERSONNEL ONLY. TO AVOID INJURY AND ELECTRICAL SHOCK DO NOT PERFORM ANY SERVICING OTHER THAN THAT CONTAINED IN THE OPERATING INSTRUCTIONS, UNLESS QUALIFIED.

FOUNDATION REQUIREMENTS

This machine is designed for use on or over bare concrete floor - not to be used above combustible flooring. The washer must be securely bolted and grouted to a substantial concrete floor, or mounted and grouted upon a suitable base that is securely bolted and grouted to a substantial concrete floor. CARE MUST BE STRESSED WITH ALL FOUNDATION WORK TO INSURE A STABLE UNIT INSTALLATION, ELIMINATING POSSIBILITIES OF EXCESSIVE VIBRATION. All installations must be made on sound concrete floors, 8 inches (203 mm) or thicker. Anchor bolts or expansion anchors must be of a quality grade and a minimum of 3/4-inch (19 mm) diameter. Six bolts are required to mount the washer to the steel base or concrete pad.

MOUNTING

A concrete pedestal or steel-mounting base that elevates the machine approximately 4 inches (102 mm) above the floor level is recommended to provide easy access to the loading door. Allow a minimum of 24 inches (610mm) of clearance behind the rear of the machine, to provide access for motor removal. Refer to Fig. 1-1 and 1-2 for machine bolt-down dimensions.

If an elevated concrete pedestal is desired, it should be embedded into the existing floor. Anchor bolts should be 3/4" x 8" (19 mm x 200 mm), grade 8 or better, headed by a 4 inch (10 cm) square fish plate and should protrude 2 1/2" (64 mm) above the finished surface of the pedestal. EXPANSION ANCHORS ARE NOT RECOMMENDED FOR USE IN CONCRETE PEDESTALS, BECAUSE THE ANCHORS ARE TOO CLOSE TO AN EDGE, CAUSING IT TO BREAK OUT. (See Fig. 1-1 and 1-3.)

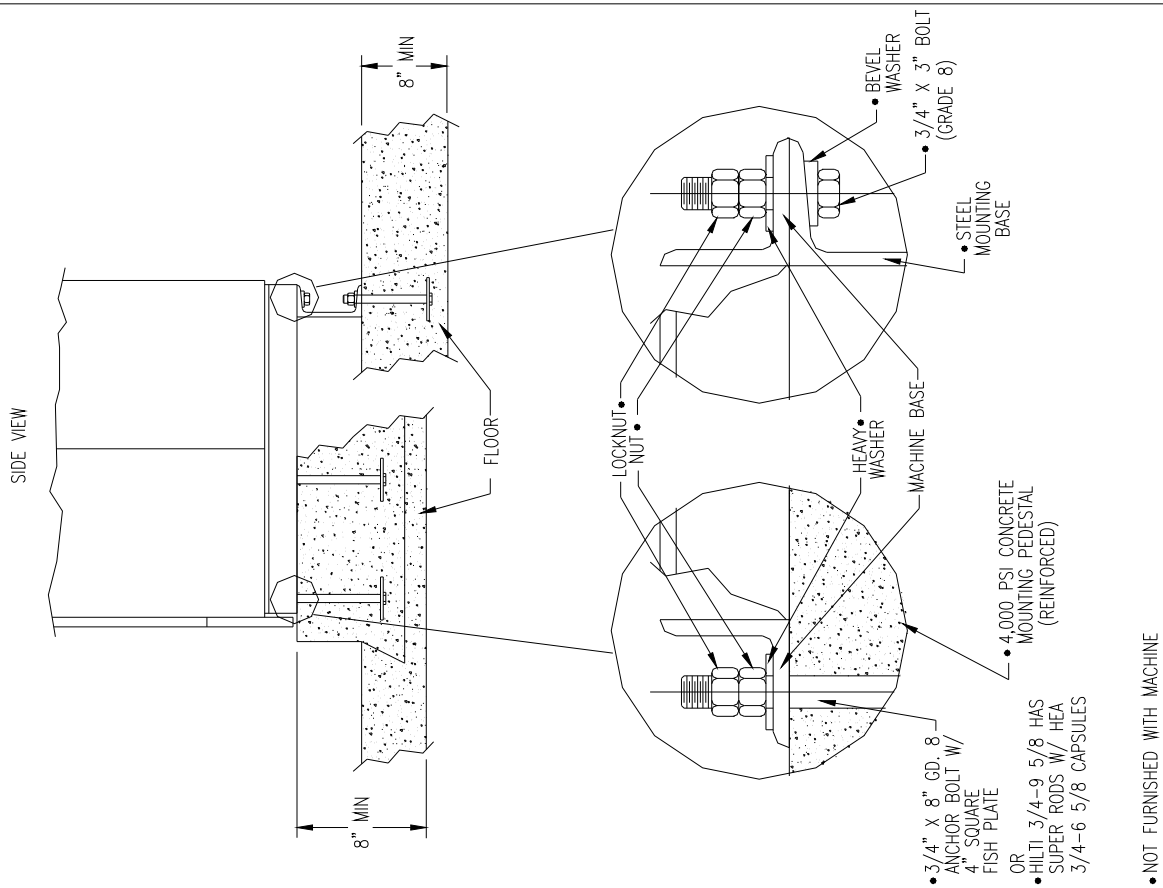

MACHINE MOUNTING DETAIL
Figure 1-3

3/4" X 8" GD. 8 BOLTS
HEADED BY 4" SQ. FISH PLATE OR EQUIV.
OR
'HILTI' ADHESIVE ANCHORING SYSTEM.
USE HILTI 'HEA' 3/4-6 5/8 ADHESIVE CAPSULES
AND HILTI 'HAS' SUPER RODS 3/4-9 5/8
FOR MORE INFORMATION CALL
HILTI CUSTOMER SERVICE
1-800-879-8000

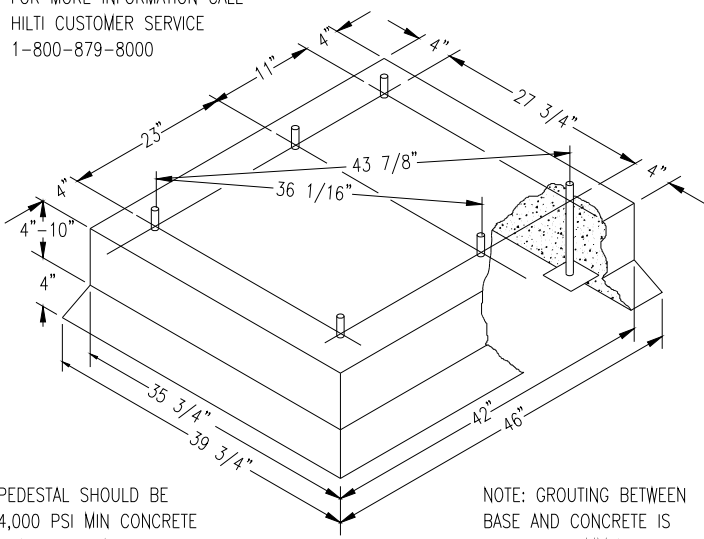

PEDESTAL SHOULD BE
4,000 PSI MIN CONCRETE
REINFORCED WITH
MESH OR RODS.

NOTE: GROUTING BETWEEN
BASE AND CONCRETE IS
HIGHLY RECOMMENDED.

CONCRETE PEDESTAL MOUNTING

Figure 1-1

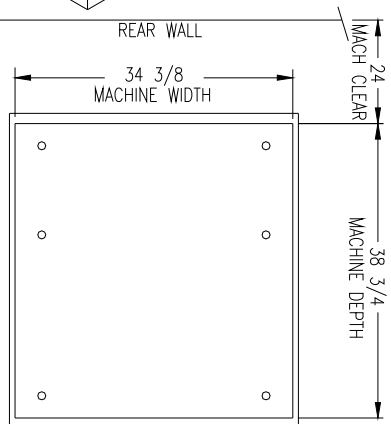
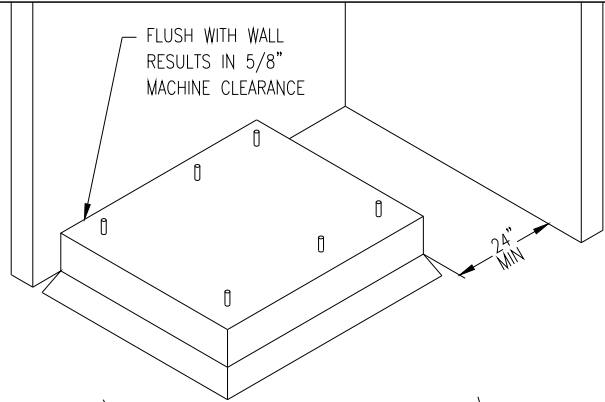

FLOOR OUTLINE

Figure 1-2

• NOT FURNISHED WITH MACHINE

PLUMBING

Water supply hoses are furnished with each machine. The threaded connections on the hoses are $\frac{3}{4}$ -11 $\frac{1}{2}$ NHT.

Separate hot and cold water lines must be provided, maintaining 30 psi to 120 psi (207 kPa to 827 kPa) water flow pressure. A 140F (60C) degree hot water supply is recommended for best washing results.

DRAIN

The drain outlet tube at the rear of the machine is 3 inches (76 mm) in diameter. Any drain hose used must be lower than the drain valve to assure proper draining.

ELECTRICAL

WARNING
SHUT OFF POWER AND WATER BEFORE OPENING ANY SERVICE PANELS.

Dexter single/three-phase 208-240VAC 60 Hz washing machines are intended to be permanently installed appliances. No power cord is provided. The machine should be connected to an individual branch circuit not shared by lighting or other equipment. The connection should be sheathed in liquid tight flexible conduit, or equivalent, with conductors of the proper size and insulation. A qualified technician should make such connections in accordance with the wiring diagram. (Suggest a minimum wire size of 12 ga.)

TO MAKE ELECTRICAL CONNECTIONS: Disconnect all power to the washer. Remove screw and lift out the cover located in the upper left corner of the machine (as viewed from the back).

- If power is 208-240-3PH-60Hz, connect L1, L2, L3 and ground. If there is a high leg it must be connected to L3.
- If power is 208-240-1PH-60Hz, connect L1, L2 and Ground.

NOTE: It is important that the grounding screw next to the power terminal block TB-1 be connected to a good external ground.

FUSING REQUIREMENTS:

SINGLE- and THREE -PHASE MODELS - 20 AMP TIME-DELAY (DUAL ELEMENT)
FUSE (or equivalent circuit breaker). *

*Note: For elevations above 6600 feet or very hot climates, a 30 amp breaker is recommended due to down-rating of circuit breakers under these conditions.

CONTROLS TRANSFORMER:

The controls transformer is located inside the control trough and steps a range of 208 to 240 volts down to 115 volts. There are two terminals on the controls transformer for the primary (incoming) power. Use the terminal marked "208V" for power supplies between 208 and 215 volts. Use the terminal marked "230V" for power supplies between 216 and 240 volts.

CHECKOUT

After all mounting, plumbing and electrical work is completed, the washer should be run through a cycle and checked for water leaks and proper functioning.

STARTING THE WASHER

A. Load the clothes into the cylinder and latch the door securely. Be sure clothing does not get caught between the door gasket and tub front when closing the door. Maximum load is 60 pounds clothes, dry weight. Do not load the washer with more than 60 lbs.

B. Select the appropriate cycle temperatures for the load being washed.

C. Add low sudsing powdered detergent into the “detergent” compartment of the automatic dispenser on the front of the washer. If desired add fabric softener to the “fabric softener” compartment. Use the amount of fabric softener as recommended by the manufacturer.

If liquid wash products are used in the “detergent” compartment, they must be added at the beginning of the wash cycle.

If the machine is set for pre-wash, washing products can be added to dispenser or put in with the clothes when loading the washing machine.

D. Insert coins, tokens or debit card to meet the displayed vend price. Once the vend price is met, the display will read “PUSH” and the start button LED will blink. If the door is not closed and latched, the display will read “DOOR” and the control will wait until the door is latched to continue. Pressing the start button will begin the cycle and activate the ON light. The display will go blank for a moment and then display the cycle time in minutes. The clothes door will lock and remain locked until the end of the cycle.

END OF CYCLE

When the cycle is complete the time will display “0” until the door is opened and a 5-second tone will sound. The door can now be opened. Leave the clothes door open when the machine is not in use.

EMERGENCY STOP / SAFETY DOOR LOCK

This machine is equipped with a Safety Door Lock that locks the door closed from when the cycle is started until the cycle is complete. The door lock prevents opening the door for up to 3 minutes if the power is interrupted during the cycle.

The Emergency Stop button pauses the washer and allows the door to be opened during the cycle after the Safety Door Lock releases. When the Emergency Stop button is pressed an alarm will sound and the display will begin counting down from “3”. If the button is released before 3 seconds elapse, the alarm will stop and the cycle will continue normally. If the Emergency Stop is held down for 3 seconds, the display will count down to “0” and the washer will begin stopping movement and water flow and begin draining water from inside the washer. Though the machine may stop wash movement quickly, it may take up to 3 minutes for the door to unlock. During that time the alarm will continue to sound. When the alarm stops, the door may be opened. The washer may be restarted by closing and latching the door, and pressing the Start button. If the washer was stopped more than once before the final extract, the cycle will be cancelled. If the washer was stopped during final extract, the cycle will be ended. If the washer is stopped for more than 1 hour, the cycle will be terminated.

SPECIFICATIONS

MODEL	T900/950 60LB WASHER
CAPACITY	60LBS/9 CUBIC FT. (27.2 kg/255 L)
CYLINDER SIZE	30” DIA X 22” DEEP (76.2cm X 55.9cm)
ELECTRICAL	208-240 VAC, 60 HZ, 1 OR 3 PHASE
DRIVE SYSTEM	SOFT START REVERSING INVERTER DRIVE
WASH SPEED	43 RPM
INTERMEDIATE EXTRACT	375 RPM (60 G’S)
FINAL EXTRACT	484 RPM (100 G’S) / 573 RPM (140 G’S) / 685 (200 G’S)
MACHINE CONTROL	PROGRAMMABLE COMPUTER WITH 6 STANDARD CYCLES.
WATER INLET	4 SOLENOID OPERATED VALVES FLOW RATE: 2 DUAL VALVES (9 GAL/MIN) EACH, 30-120 PSI,
DRAIN VALVE	2 SINGLE VALVES (12 GAL/MIN) EACH, 30-120 PSI 3” DIAMETER

PROGRAMMING INSTRUCTIONS:

Programming can be accomplished manually using the machine controls or by connecting to the machine control using a PDA (personal digital assistant). For instructions on using a PDA with this washer control, please contact your local Dexter distributor. Please read below for manual programming instructions.

The washer has two levels of programming. The Coin/Price Programming allows the owner to set the price for the washer features and the values of the coins. The Washer Cycle Programming allows the owner complete access to the wash cycle parameters – add/remove a bath, bath times, spin times, water temperatures, etc. To enter the programming modes, the top of the washer must be unlocked and slid toward the back of the washer a few inches.

COIN PRICE PROGRAMMING

While the washer is in the Idle mode, push the Programming pushbutton on the controller. The Idle mode is when the washer is not running a cycle and the price of the bath is displayed. The Programming pushbutton is a very small button located on the upper center of the controller directly behind the display. There are seven stages in the Coin/Price Programming mode.

To step through to the desired stage, repeatedly push the START button until the desired stage is blinking on the display. To exit the Coin/Price programming mode, push and hold the Cold temperature button for 5 seconds.

Stage 1: Right Coin – The display will blink first a “r” indicating right coin and then a coin value (\$1.00 – default). The display will blink back and forth between the “r” and the value. To change the value, use the Hot temperature button to decrease and the Warm temperature button to increase. The value will change in 1¢ steps. The range of values is from \$00.00 to \$99.99. When the desired right coin value is displayed, push the Start button once to store the new value and a second time to move to the next Coin/Price programming step.

To exit the Coin/Price programming mode, push the Cold temperature button for 5 seconds.

Stage 2: Left Coin – The display will blink first a “L” indicating left coin and then a coin value (\$0.25– default). The display will blink back and forth between the “L” and the value. To change the value, use the Hot temperature button to decrease and the Warm temperature button to increase. The value will change in 1¢ steps. The range of values is from \$00.00 to \$99.99. When the desired left coin value is displayed, push the Start temperature button once to store the new value and a second time to move to the next Coin/Price programming step. To exit the Coin/Price programming mode, push the Cold temperature button for 5 seconds.

Stage 3: Wash Price – The display will blink first a “P” indicating wash price and then present wash price. The display will blink back and forth between the “P” and the price. To change the value, use the Hot temperature button to decrease and the Warm temperature button to increase. The value will change in 1¢ steps. The range of values is from \$00.00 to \$99.99. If the wash price is set to \$00.00, the display will show “FREE” after exiting the programming mode. When the desired price is displayed, push the Start button once to store the new value and a second time to move to the next Coin/Price programming step. To exit the Coin/Price programming mode, push the Cold temperature button for 5 seconds.

WATER TEMPERATURE PRICING

The washer can be set for different levels of pricing for Cold, Warm and Hot water. The Cold water setting is considered as the base price, which is the normal washer cycle price.

Stage 4: Warm Water Price – The next step in the pricing program is to set the additional price for Warm water usage. The additional price is the amount added to the price of a cold wash. The display will blink first “CH P” indicating cold/hot water mix price and then “00.00”. To change the value, use the Hot temperature button to decrease and the Warm temperature button to increase. The value will change in 1¢ steps. The range of values is from \$00.00 to \$99.99.

Note: To not use this feature, set the price to “00.00”.

When the desired price is displayed, push the Start button once to store the new value and a second time to move to the next Coin/Price programming step. To exit the Coin/Price programming mode, push the Cold temperature button for 5 seconds.

Stage 5: Hot Water Price – The next step in the pricing program is to set the additional price for Hot water usage. The additional price is the amount added to the price of a cold wash. The display will blink first “H P” indicating hot water price and then “00.00”. To change the value, use the Hot temperature button to decrease and the Warm temperature button to increase. The value will change in 1¢ steps. The range of values is from \$00.00 to \$99.99.

Note: To not use this feature, set the price to “00.00”.

When the desired price is displayed, push the Start button once to store the new value and a second time to move to the next Coin/Price programming step. To exit the Coin/Price programming mode, push the Cold temperature button for 5 seconds. The Coin/Price programming mode will automatically exit and return to the Idle mode if no buttons are pushed for one minute.

Stage 6: Plus Cycle Price -- The next step in the programming sequence is the Plus Cycle feature. The Plus Cycle adds three (3) minutes of wash time to the wash bath only. The controller can be programmed to charge a fee for this or the feature can be turned off. The default setting is off. To turn the Plus Cycle feature off, set the Plus Cycle price to zero.

The display will blink first a “PC P” indicating Plus Cycle price and then price (back and forth). To change the value, use the Hot temperature button to decrease and the Warm temperature button to increase. The value will change in 1¢ steps. The range of values is from \$00.00 to \$99.99. When the desired price is displayed, push the Start temperature button once to store the new value and a second time to move to the next Coin/Price programming step. To exit the Coin/Price programming mode, push the Cold temperature button for 5 seconds.

Stage 7: Decimal Point -- The next step in the programming sequence is the decimal point display. The display will start blinking back and forth first “dP “ (Decimal Point) and then either “on” (default) or “off”. Press the Hot or Warm temperature buttons to select the decimal point display as “on” or “off”. When the desired setting is displayed, push the Start button to store it and a second time to move to the next programming step.

WASH CYCLE PROGRAMMING

To change a feature of the wash cycle, push and hold the Hot temperature button and then push the programming pushbutton on the controller. The Washer must be in the Idle mode to enter the Wash Cycle Programming mode. When entering the cycle programming mode, the Bleach LED will start to blink and continue to blink as long as you are in the Cycle Programming mode.

The display will show “C 0”. This is the default cycle number.

Note: The washer can be returned to the factory default settings by holding the Start button and then pressing the Warm button. The display must show “C 0” to do this. When the cycle default values are loaded, the washer will automatically exit the programming mode.

Note: The Wash Cycle programming mode will automatically exit and return to the Idle mode if no buttons are pushed for one minute.

End of Cycle Alarm: The end of cycle alarm can be turned on or off by pushing the Hot or Warm temperature buttons until “AL” is displayed and pressing the Start button. The display will now read “on” or “off” and can be changed by pressing the Hot or Warm temperature buttons. When the desired setting is displayed, press Start again to save.

Modifying the Wash Cycle: To change the wash cycle, push the Hot or Warm temperature buttons until the display changes to “C 1”, indicating cycle one is selected. The temperature buttons are used to make changes to the program. In the program mode, the buttons will do the following:

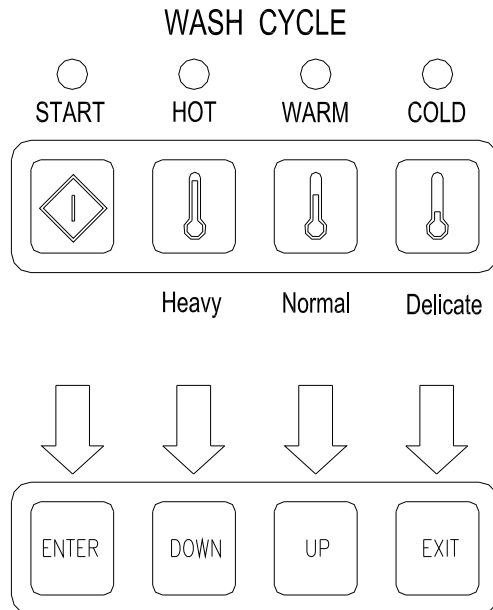

When the display shows “C 1”, push Enter. The display will show “b” and the PreWash mode light will blink. Use the Up/Down buttons to move to the bath that will be changed. As Up/Down buttons are pushed, the next bath mode light turns on.

When the Up button is pushed, the bath mode light changes from Prewash to Wash. With each

additional push of the Up button, the lit bath mode changes from left to right: Prewash, Wash, Rinse and Final Rinse. As there are two possible Rinse bathes, for Rinse1 the Rinse LED and the display changes to “b” in the left digit and “r1” in the two right hand digits. For Rinse2, the display changes to “b” in the left digit and “r2” in the two right hand digits. Note that the Spin light is not used. When the Down button is pushed, the bath mode light changes from Prewash to Final Rinse, etc. There is a wrap around feature in both directions. When the desired bath mode light is on, push Enter.

The selected bath LED begins to blink. The display shows the letters “ct” in the left two digits and the bath cycle time in the right two digits. Again the up/down buttons change this value. The range is shown below. If zero time is entered, then the bath will be skipped and the program will return to the bath selection. When the desired cycle time is selected, push enter.

The display shows the letter “t” in the left digit and the letters “CC” appear in the right two digits. This is the bath water temperature. The selection choices are shown below but for the coin washer the value is defaulted to CC. When the desired temperature is selected, press enter.

The display shows the letter “L” in the left digit and the letters “LO” appear in the right two digits. This is the bath water level. The selection choices are shown below but for the coin washer the value is defaulted to LO. As it is not selectable with a coin washer, the owner pushes enter to continue.

The display shows the letters “dF” in the left two digits and the letter “t” appears in the right digit. This is the bath delay fill. The selections are “t” for counting down bath time during the fill or “d” for delay the bath time until water level is reached. When the desired selection is made, push enter.

The display shows the letter “S” in the left digit and the bath spin time in the right two digits. Again the up/down buttons change this value. The range is shown below. When the desired spin time is selected, push enter.

The display shows the letters “IS” in the left two digits and the injection selection appear in the right digit. For the coin washer the default value is “0” and cannot be changed. Push enter twice.

At this point the bath LED stops blinking. The display will show “b” and the next bath LED lights. Again use the up/down buttons to change the bath selection. *To exit the programming mode, push and hold exit for 5 seconds.* The cycle will be stored when exiting the programming mode.

COIN WASHER CYCLE PARAMETER RANGES

The range of each cycle parameter is shown below:

Cycle Time “ct”	0 to 15 minutes for Prewash, Rinse1 and Rinse2 3 to 15 minutes for Wash and Final Rinse For the bathes that can, if the time is set to zero, then the bath will be eliminated from the cycle.
Water Temperature “t”	HH – hot, CH – warm, CC – cold The owner can set the bath default. For the wash bath, the customer overrides the default for that cycle when the temperature is selected.
Water Level “L”	LO – low The owner can change the displayed value, but for a coin washer only LO will be put into the cycle.
Delay Fill “dF”	The selections are “d” for delay the bath time until water level is reached or “t” to countdown bath time during the fill.
Spin Time “S”	0 to 10 minutes for Prewash, Wash, Rinse1 and Rinse2 1 to 10 minutes for Final Spin.
“IS”	The owner can change the displayed value, but for a coin washer only 0 will be put into the cycle.

COIN WASHER DEFAULT CYCLE

The following table shows the complete details for the coin washer default cycle.

Bath	Bath Cycle Time (min.)	Water Temp.	Water Level *	Delay Fill	Spin Time (min.)	IS *
Prewash	0	CC	LO	t	0	0
Wash	9	CH	LO	t	0	0
Rinse 1	4	CC	LO	t	1	0
Rinse 2	0	CC	LO	t	0	0
Final Rinse	5	CC	LO	t	4	0

Note * These default values are preset and cannot be changed.

RAPID ADVANCE MODE

To enter the Rapid Advance mode, push and hold the Cold water temperature button and then push the programming button on the controller. There will be no observed change to the washer or the display. The Rapid Advance mode can be entered from either the Idle mode or during the cycle. To rapid advance to the next step in the wash cycle, push the Start and Warm temperature buttons at the same time. The display will show an “Ad” (advance) in the display. The washer will advance to the next bath segment. The water will drain before the advance will occur.

The Rapid Advance mode will not end until the final bath segment is completed. The final segment cannot be skipped in Rapid Advance mode.

Notes: 1. When the Rapid Advance mode is used, the cycle time will no longer be correct.
2. By skipping steps with rapid advance, the door may not open immediately at the end of the cycle.

EASY CARD

If your Dexter washer is installed with Dexter’s Easy Card debit card system, the card reader signals the washer control when money is debited from the user’s card account to satisfy the price of the wash cycle. The washer’s pricing and the Easy Card system pricing are completely independent of each other and must be programmed separately and coordinated. Refer to the instructions that came with the Easy Card system for complete information.

SETTING THE ELECTRONIC COIN ACCEPTOR SWITCHES

Some washer models come equipped with an electronic coin acceptor. Follow the instructions below for setting the switches for the desired country and currencies.

- 1) The electronic coin acceptor has switch settings depending on the coins and country. See the table below for available values of the left and right coin inputs for the available countries.

WARNING: TURN POWER OFF BEFORE AND LEAVE POWER OFF WHEN CHANGING THE SWITCHES OF THE ELECTRONIC COIN ACCEPTOR.

- 2) Turn power back on and test coins to ensure proper operation.

Acceptor P/N	Country	Left Coin	Right Coin	SWs 1-8	SWs 9-16	
9021-010-001	Canada	25¢		↓↓↑↑↑↑↑↓	↓↑↑↑↑↑↑↓	
	Canada		\$1	↑↑↓↓↑↑↑↓	↓↑↑↑↑↑↑↓	
	Canada		\$2	↑↑↑↑↑↓↓↓	↓↑↑↑↑↑↑↓	
	Japan	100¥		↓↓↑↑↑↑↑↓	↑↓↑↑↑↑↑↓	
	Japan		500¥	↑↑↓↓↑↓↓↓	↑↓↑↑↑↑↑↓	
	Taiwan	10NT		↓↓↑↑↑↑↑↓	↑↑↓↑↑↑↑↓	
	Taiwan		50NT	↑↑↓↓↑↓↓↓	↑↑↓↑↑↑↑↓	
	Korea	500W		↓↓↑↑↑↑↑↓	↑↑↑↓↑↑↑↓	
		Greenwald 118-1 Token		↑↑↑↑↑↑↑↓	↑↑↑↑↓↑↑↓	
		Greenwald 118-5 Token		↑↑↑↑↑↑↑↓	↑↑↑↑↑↓↑↓	
		U.S.A.	25¢		↓↓↑↑↑↑↑↓	↑↑↑↑↑↑↑↓
		U.S.A.		\$1	↑↑↓↓↑↑↑↓	↑↑↑↑↑↑↑↓
9021-011-001	Australia	10¢		↓↓↑↑↑↑↑↓	↑↓↑↑↑↑↑↓	
	Australia	20¢		↑↑↓↓↑↑↑↓	↑↓↑↑↑↑↑↓	
	Australia		\$1	↑↑↑↑↓↑↑↓	↑↑↓↑↑↑↑↓	
	Australia		\$2	↑↑↑↑↑↓↓↓	↓↑↓↑↑↑↑↓	
	New Zealand	10¢		↓↓↑↑↑↑↑↓	↑↓↑↑↑↑↑↓	
	New Zealand	20¢		↑↑↓↓↑↑↑↓	↑↓↑↑↑↑↑↓	
	New Zealand		\$1	↑↑↑↑↓↑↑↓	↑↑↑↓↑↑↑↓	
	New Zealand		\$2	↑↑↑↑↑↓↓↓	↓↑↓↑↑↑↑↓	
	Hong Kong	\$5		↓↓↓↓↑↑↑↓	↑↑↑↑↓↑↑↓	
	Hong Kong		\$10	↑↑↑↑↓↑↑↓	↑↑↑↑↓↑↑↓	
		Greenwald 118-1 Token		↑↑↑↑↑↑↑↓	↑↑↑↑↑↓↑↓	
		Greenwald 118-5 Token		↑↑↑↑↑↑↑↓	↑↑↑↑↑↑↑↓	

Switches ↑=up/on, ↓=down/off

Note: Coins and tokens in the left coin column will result in one pulse to the left coin input.

Note: The \$1, 500¥, 50NT, and \$10 coins in the right coin column will result in one pulse to the right coin input, while the \$2 coins will result in two pulses to the right coin input.

Note: Acceptance of multiple coins per country and multiple tokens is allowed. Only the down/off setting for each coin and token is required to accept that coin or token.

WASHER ERROR CODES

Fault# (F #)	Description	Customer Action
1	The door failed to close and lock or the door failed to remain locked after three tries of latching the door and starting during the cycle.	Turn off the power to the washer. Check wire connections to door /lock switches. Check wire connections from switches to controller. If necessary door lock mechanism should be adjusted by a qualified person. Turn on the power to the washer. (See Note)
2	The washer tub does not fill with water within 7 minutes. The wash cycle will continue. The F 2 will flash three times, then wait for 30 seconds. The error will clear at the end of the cycle.	Turn of the power to the washer. Check the operation of the water valves. Check the incoming water pressure. Check for blocked or restricted water flow. Check to ensure the drain valve is functioning properly. Turn on the power to the washer. (See Note)
3	Memory error in controller.	Turn off the power to the washer. Wait one minute. Turn power back on to the washer. If the problem returns, clear the fault with the Palm. If the problem returns again, replace the washer controller.
4	Washer controller communication error	Turn off the power to the washer. Wait one minute. Turn power back on to the washer. If the problem returns, replace the washer controller.
5	Pressure Switch error (only OPL)- when the high level sensor indicates full but the lower one indicates empty. The wash cycle will continue. The F 5 will flash three times, then wait for 30 seconds. The error will clear at the end of the cycle.	Turn off the power to the washer. Replace the pressure switch. Turn on power to the washer. (See Note)
6	Wrong washer size for drive type.	Turn off the power to the washer. Check to ensure all the harnesses are properly connected to the controller. Check to ensure the drive horsepower is proper for this size of washer. Turn on power to the washer. (See Note) If problem reappears, contact your Dexter representative.
7	Wrong size drive installed	Turn off the power to the washer. Check to ensure all the harnesses are properly connected to the controller. Check to ensure the drive horsepower is proper for this size of washer. Contact your Dexter representative.
8	The washer tub does not empty within 7 minutes. The wash cycle will continue. The F 8 will flash three times, then wait for 30 seconds. The error will clear at the end of the cycle.	Turn off the power to the washer. Check to ensure the drain valve is operating properly. Check to ensure the pressure switch tube is clear of blockage. Check to ensure the pressure switch is operating proper. Correct any located problems. Turn on power to the washer. (See Note)
9	The washer tub does not reach the spin target frequency within 200 seconds. The wash cycle will continue. The F 9 will flash three times, then wait for 30 seconds. The error will clear at the end of the cycle.	Turn off the power to the washer. Inspect the washer to ensure the tub spins freely. If restricted, then clear the blockage. Test washer. If tub spins freely, the drive needs to be replaced.
10	After a spin the washer tub does not stop within 150 seconds.	Turn off the power to the washer. Inspect the braking resistors and the connecting wiring to the drive braking resistors mounted in the top of the washer. If the resistors and wiring is correct, then replace the drive.

11	The drive size setting has changed.	Turn off the power to the washer. Check to ensure all the harnesses are properly connected to the controller. Check to ensure the drive horsepower is proper for this size of washer. Turn on power to the washer. (See Note) If problem reappears, contact your Dexter representative.
12	Washer controller internal error	Turn off the power to the washer. Wait one minute. Turn on the power to the washer. (See Note) If problem reappears, contact your Dexter representative.
13	The control can not communicate with the drive	Turn the power off to the washer. Check the data cable between the controller and the drive. If no problem is observed, turn on power to the washer and test. (See Note) If problem reappears, contact your Dexter representative.
14	Over-current on the drive or motor.	Turn the power off to the washer. Check the washer motor to ensure it turns freely. Check the wiring connections to the drive and motor. If no problem is observed, turn on power to the washer and test. (See Note) If problem reappears, contact your Dexter representative.
15	Over-voltage on the drive or motor.	Turn the power off to the washer. Check the washer motor to ensure it turns freely. Check the wiring connections to the drive, braking resistors and motor. Measure incoming line voltage. If no problem is observed, turn on power to the washer and test. (See Note) If problem reappears, contact your Dexter representative.
16	Overheating of the drive	Turn the power off to the washer. Allow the drive to cool. Check the cooling fins of the drive to ensure proper airflow. Check the wiring to the drive including the fan wiring. If no problem is observed, turn on power to the washer and test. (See Note) If problem reappears, contact your Dexter representative.
17	Overload of the drive or motor	Turn the power off to the washer. Check the washer motor to ensure it turns freely. Check the wiring connections to the drive and motor. If no problem is observed, turn on power to the washer and test. (See Note) If problem reappears, contact your Dexter representative.
18	Ground Fault to the drive	Turn the power off to the washer. Check the wiring connections to the drive and motor. Check the ground wiring of the drive, motor and incoming connection to ensure a proper ground is present. If no problem is found, contact your Dexter representative.
19	Low Voltage to the drive	Turn the power off to the washer. Check the wiring connections to the drive and motor. If no problem is observed, turn on power to the washer and test. (See Note) Measure the incoming line voltage. If problem reappears, contact your Dexter representative.
20	Internal drive error	Turn the power off to the washer. Wait one minute. Turn the power on to the washer. (See Note) If problem reappears, contact your Dexter representative.
21	Data error on communications between the controller and drive	Turn the power off to the washer. Check the data cable between the controller and the drive. If no problem is observed, turn on power to the washer and test. (See Note) If problem reappears, contact your Dexter representative.

Note: Whenever power is turned off to the washer, it **must** remain off for one minute. The washer will not operate properly if this is not done.

ACCESSORIES

INSTALLATION: (Furnished)

		QTY. 900/950
9990-027-011	Hose, Water Supply	2/4
8641-242-000	Washer, Inlet Hose	2/4
9565-003-001	Strainer, Inlet Hose	4/8

Contact your distributor or Dexter Laundry, Inc. if a steel-mounting base is required.

www.dexterlaundry.com