



DEXTER[®]
LAUNDRY



WCVD-WN Series OPL Washers
Schematics 50Hz

T-300 WN0300XA-39 230VAC 50Hz Wiring Diagram

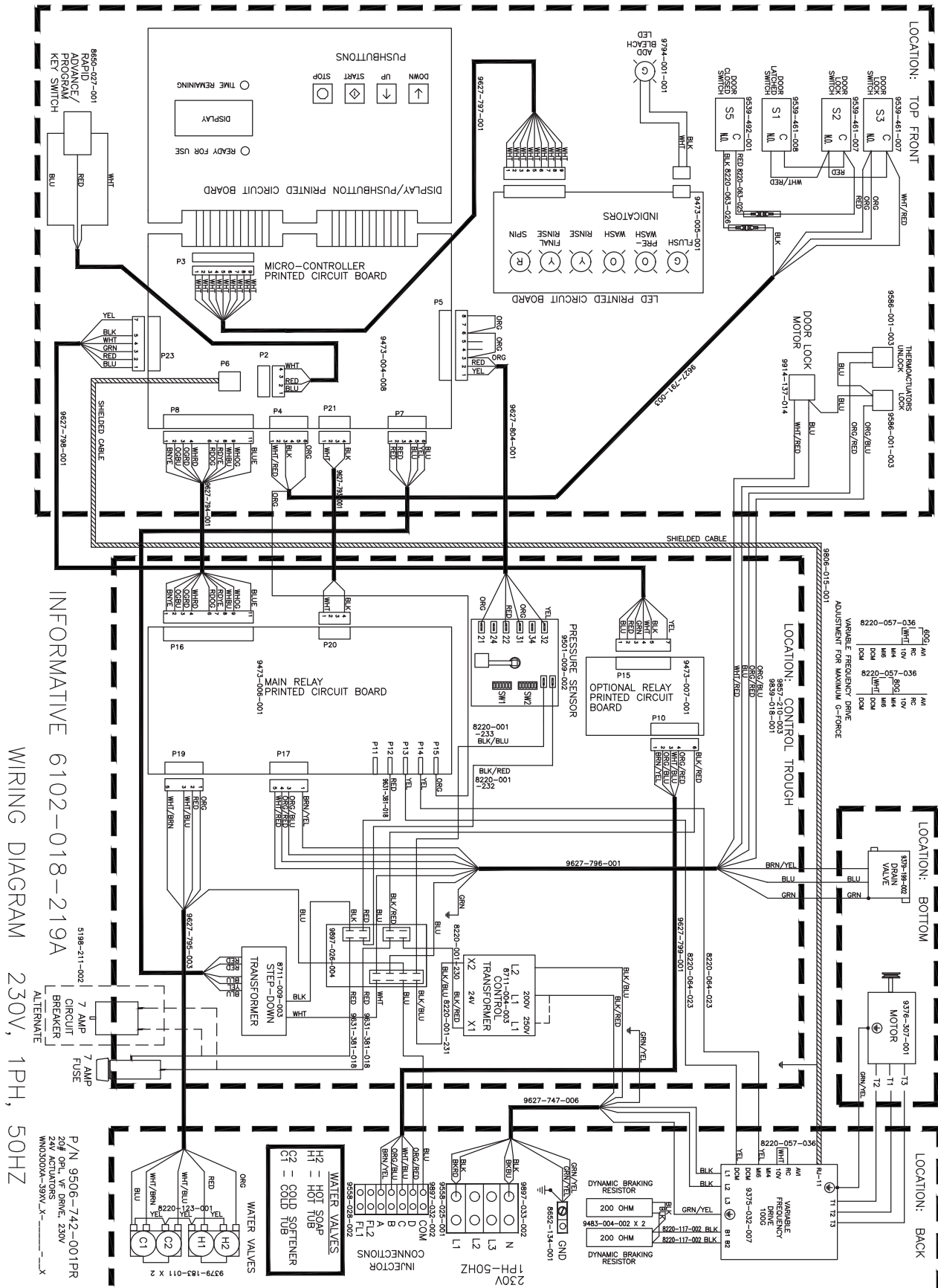

INFORMATIVE 6102-018-219A

WIRING DIAGRAM 230V, 1PH, 50HZ

T-300 WN0300XA-39 230VAC 50Hz Wiring Schematic

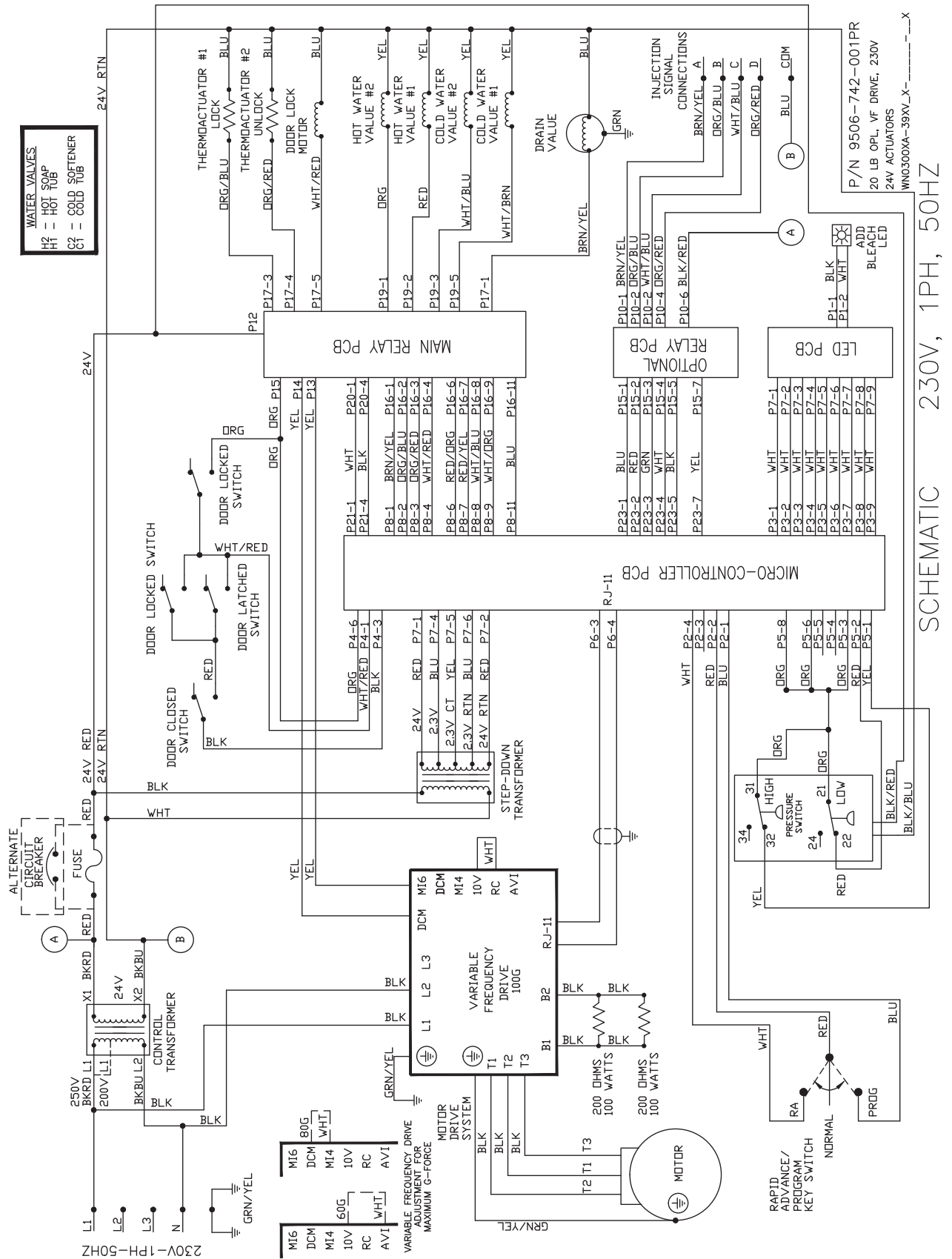

T-350 WN0350XA-39 230VAC 50Hz Wiring Diagram

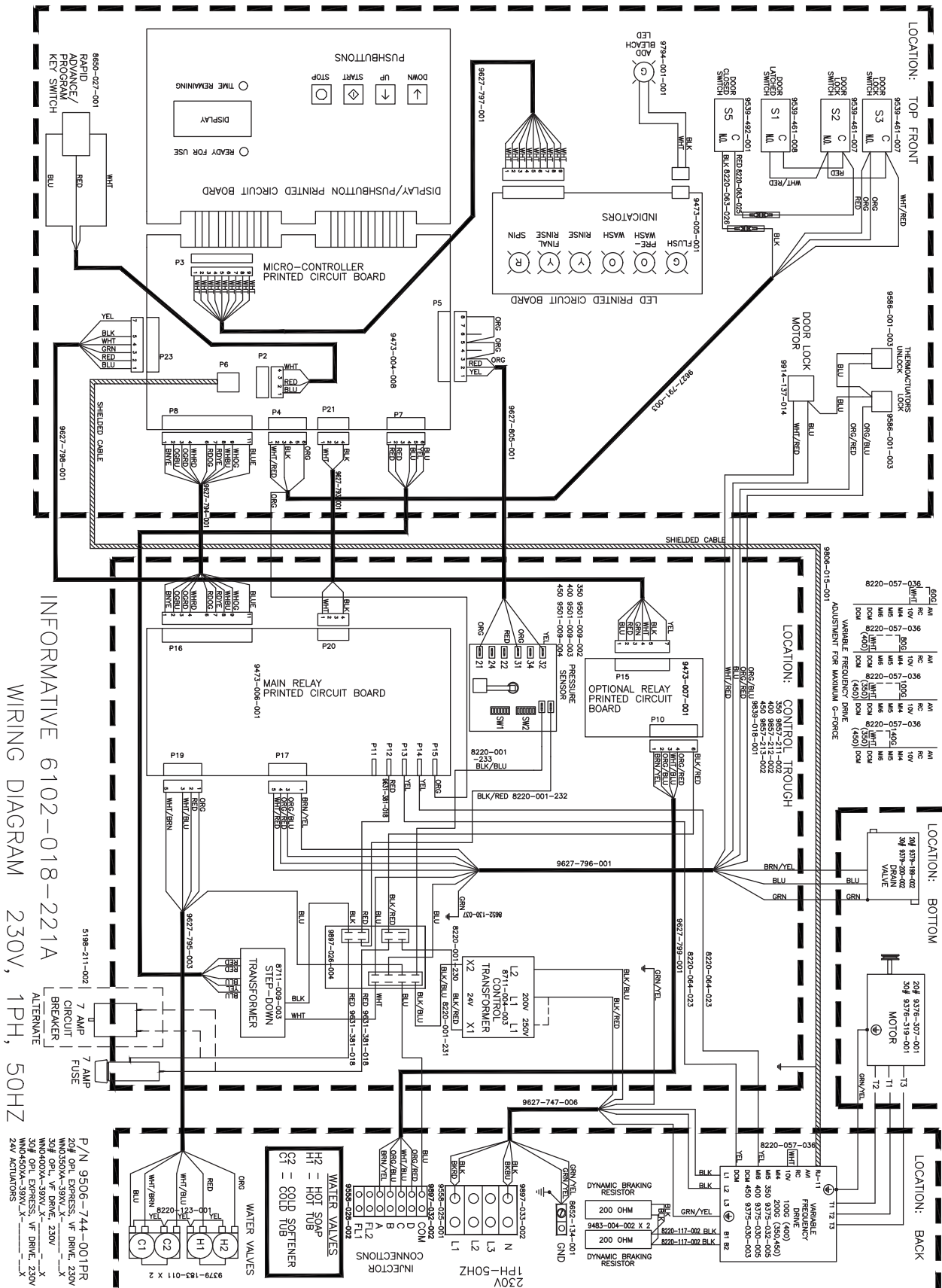

T-350 WN0350XA-39 230VAC 50Hz Wiring Schematic

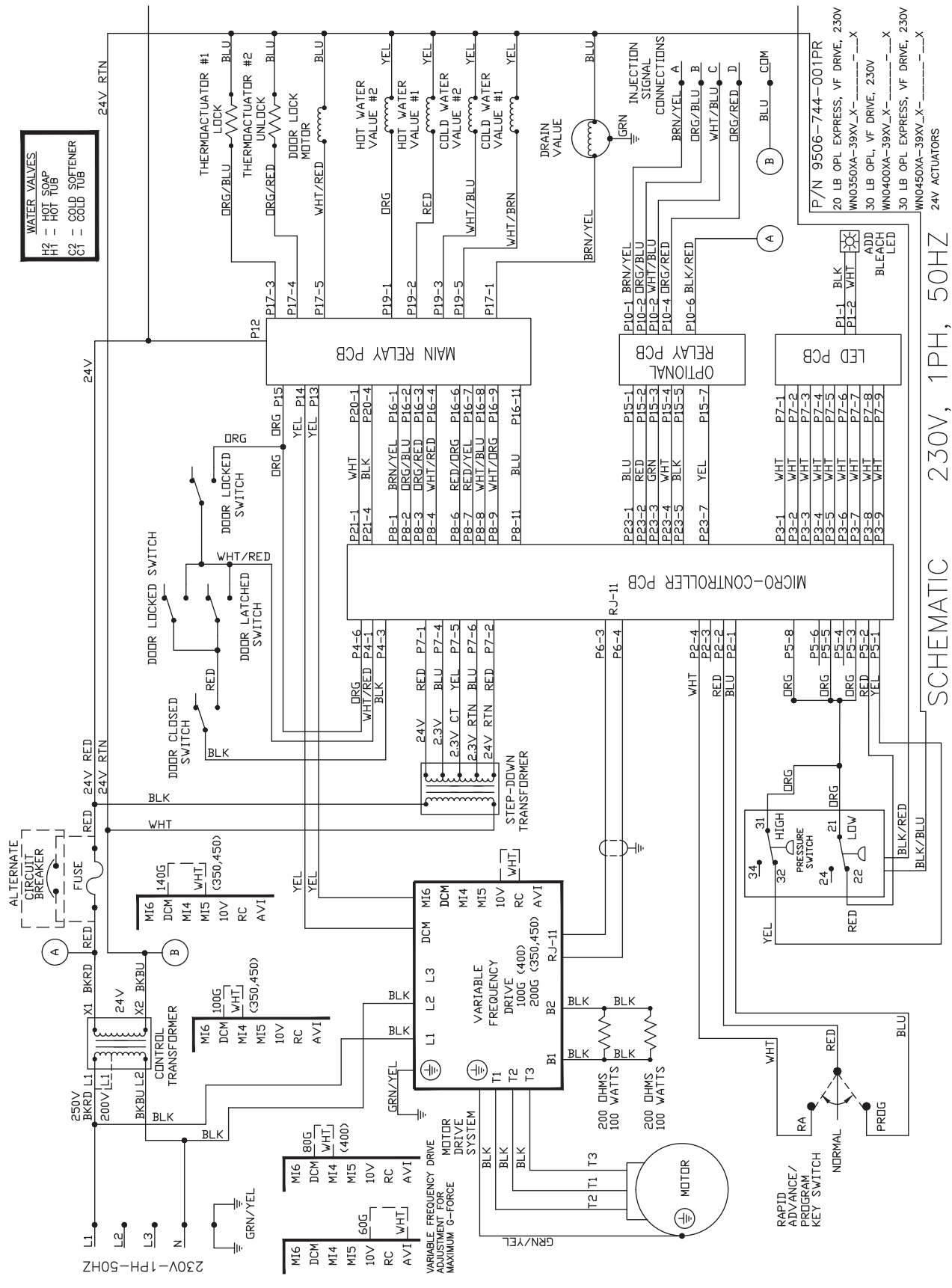

T-400 WN0400XA-39 230VAC 50Hz Wiring Diagram

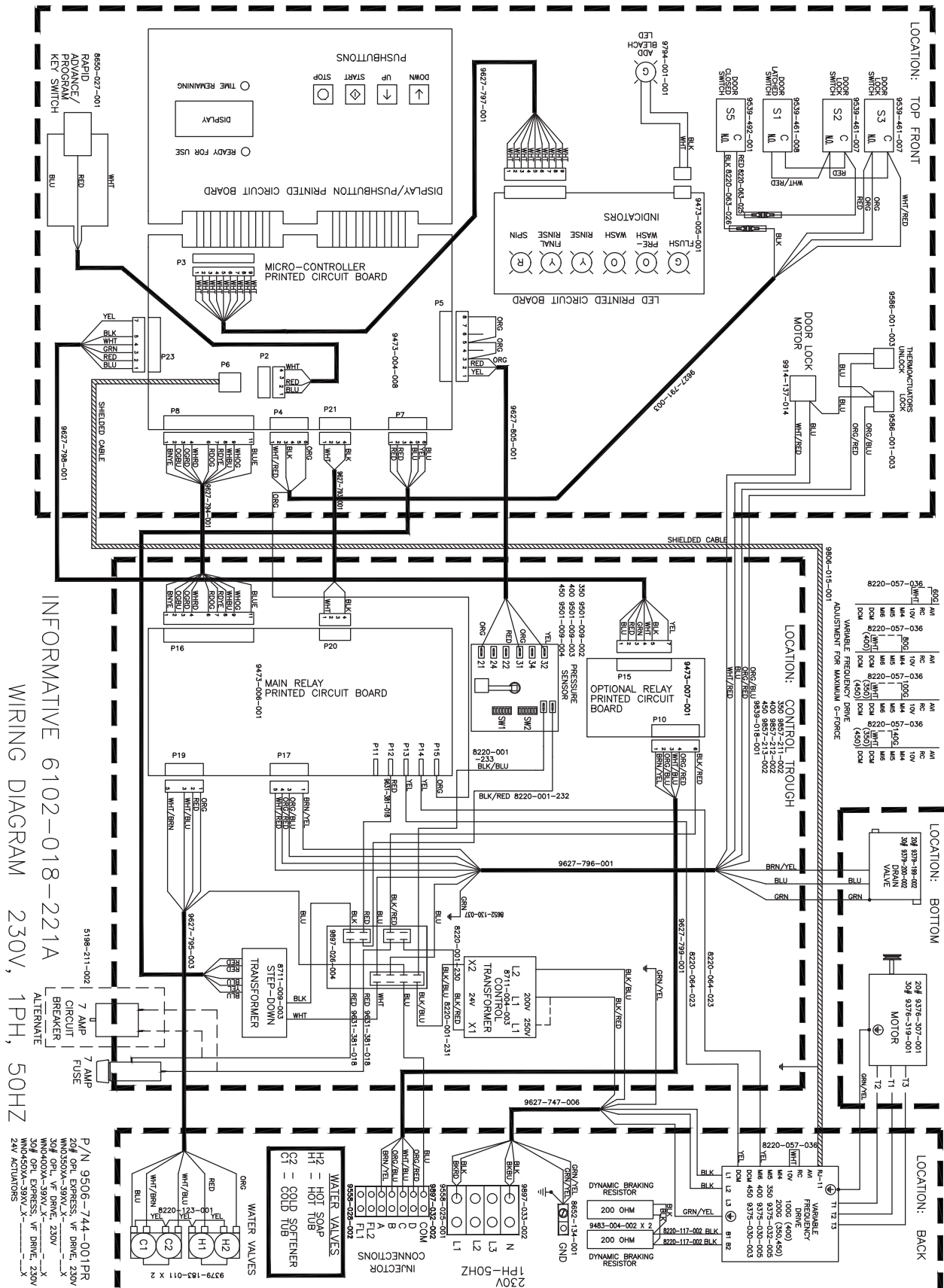

T-400 WN0400XA-39 230VAC 50Hz Wiring Schematic

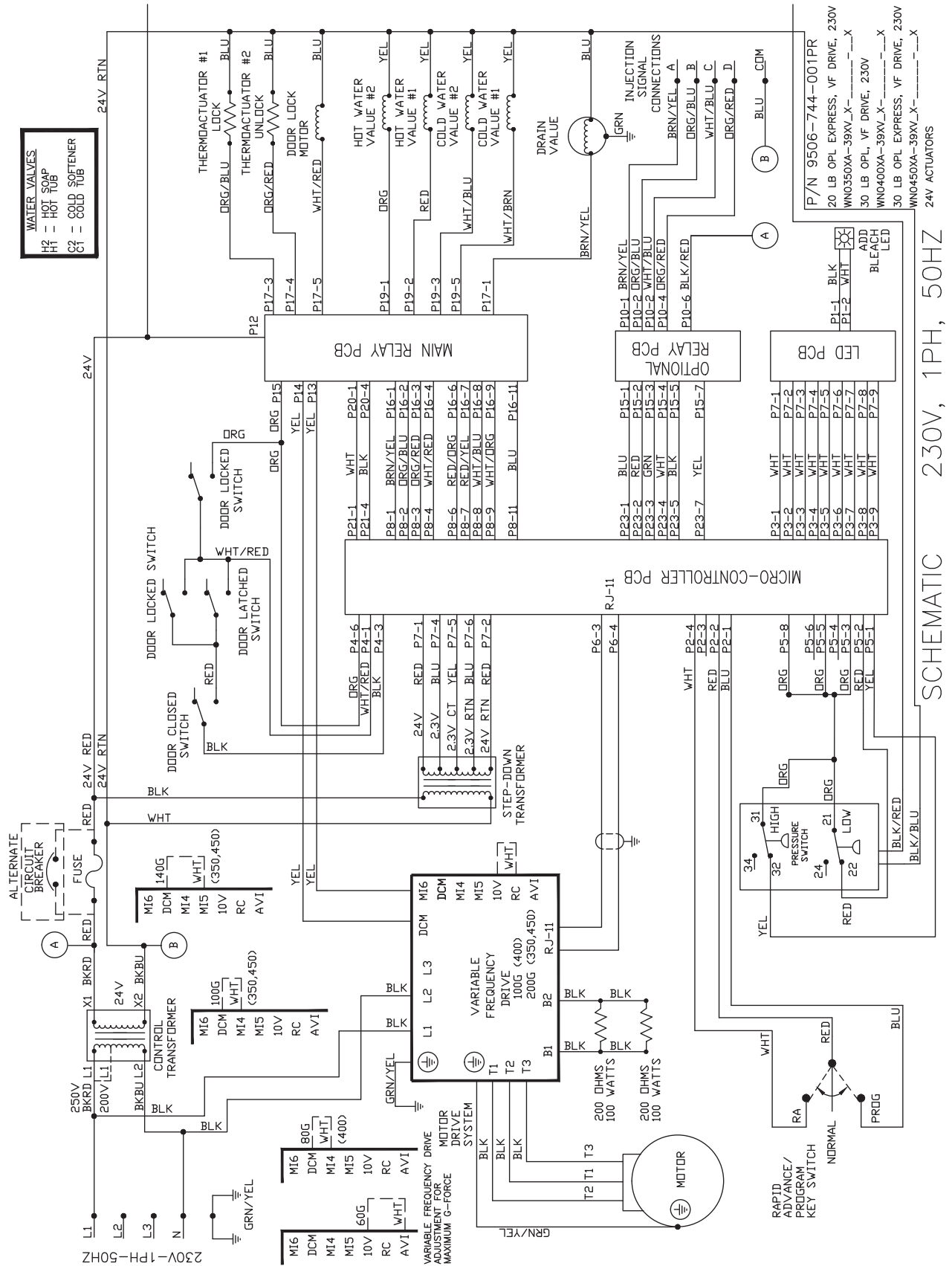

SCHEMATIC 230V, 1PH, 50HZ

T-450 WN0450XA-39 230VAC 50Hz Wiring Diagram

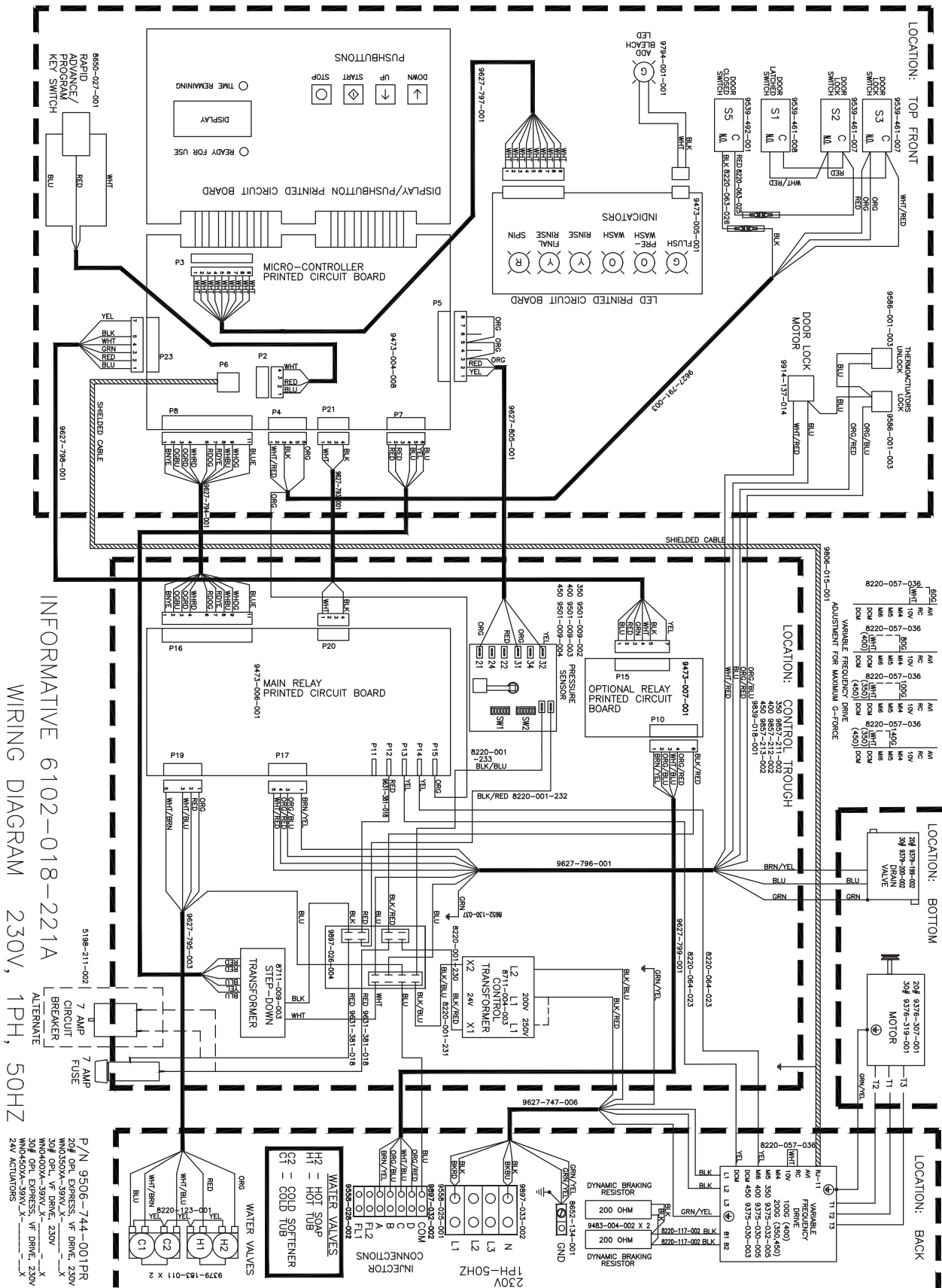

T-450 WN0450XA-39 230VAC 50Hz Wiring Schematic

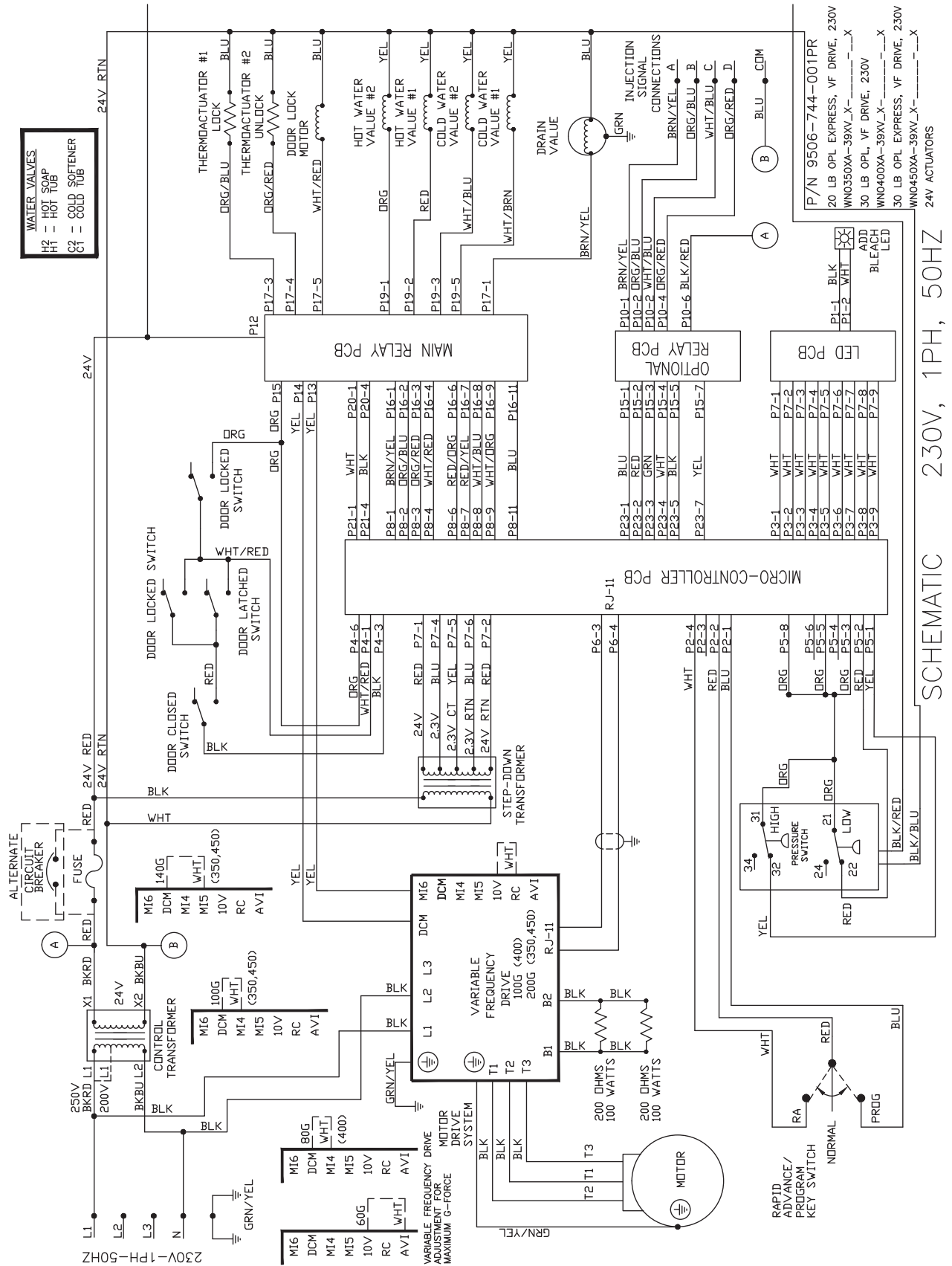

SCHEMATIC 230V, 1PH, 50HZ

T-600 WN0600XA-39 230VAC 50Hz Wiring Diagram

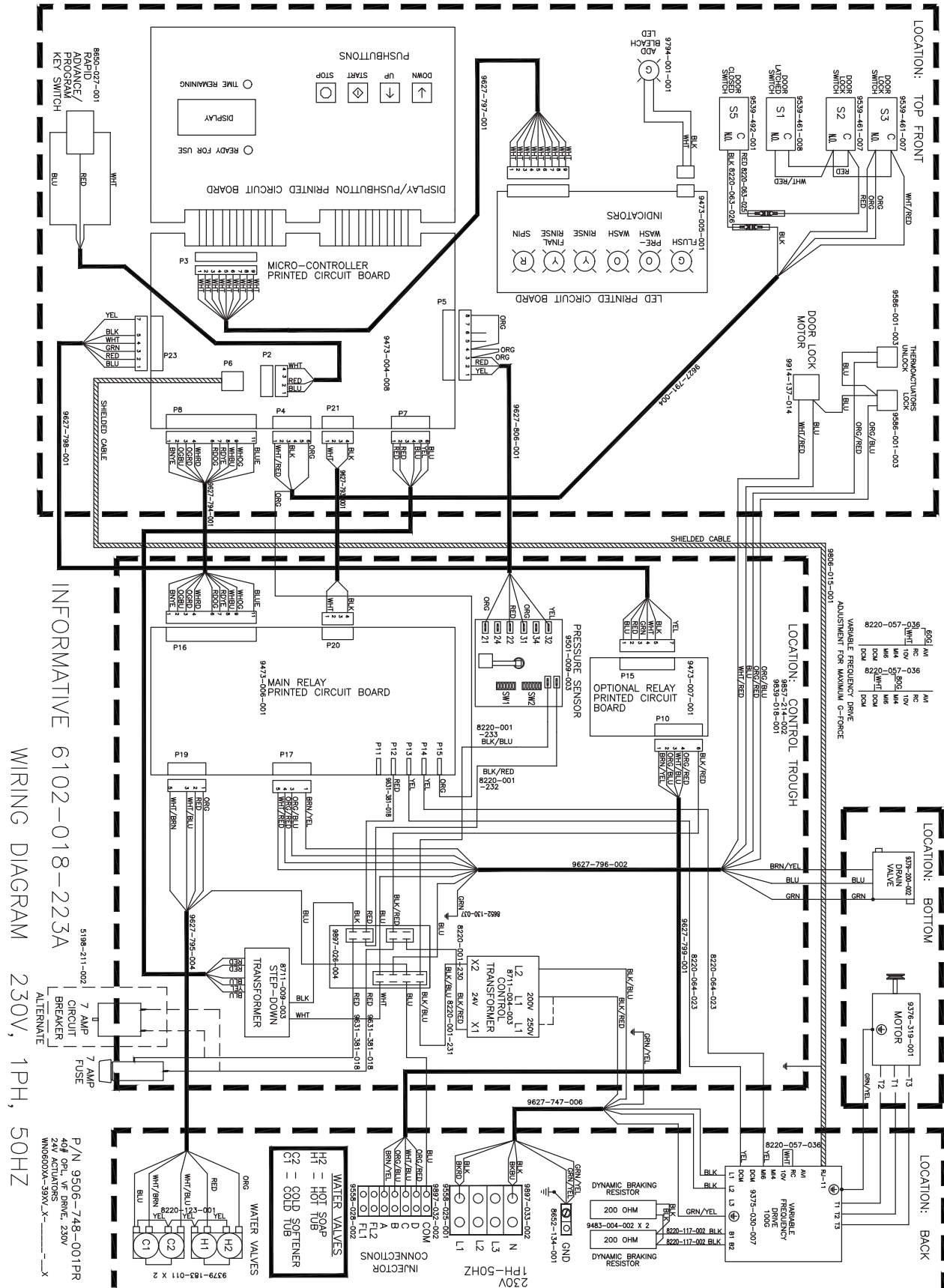

INFORMATIVE 6102-018-223A
WIRING DIAGRAM

230V, 1PH, 50HZ
P/N 9506-748-001PR
40# OF L.V. PRIME, 230V
WN0600XA-39U, X-...-X

T-600 WN0600XA-39 230VAC 50Hz Wiring Schematic

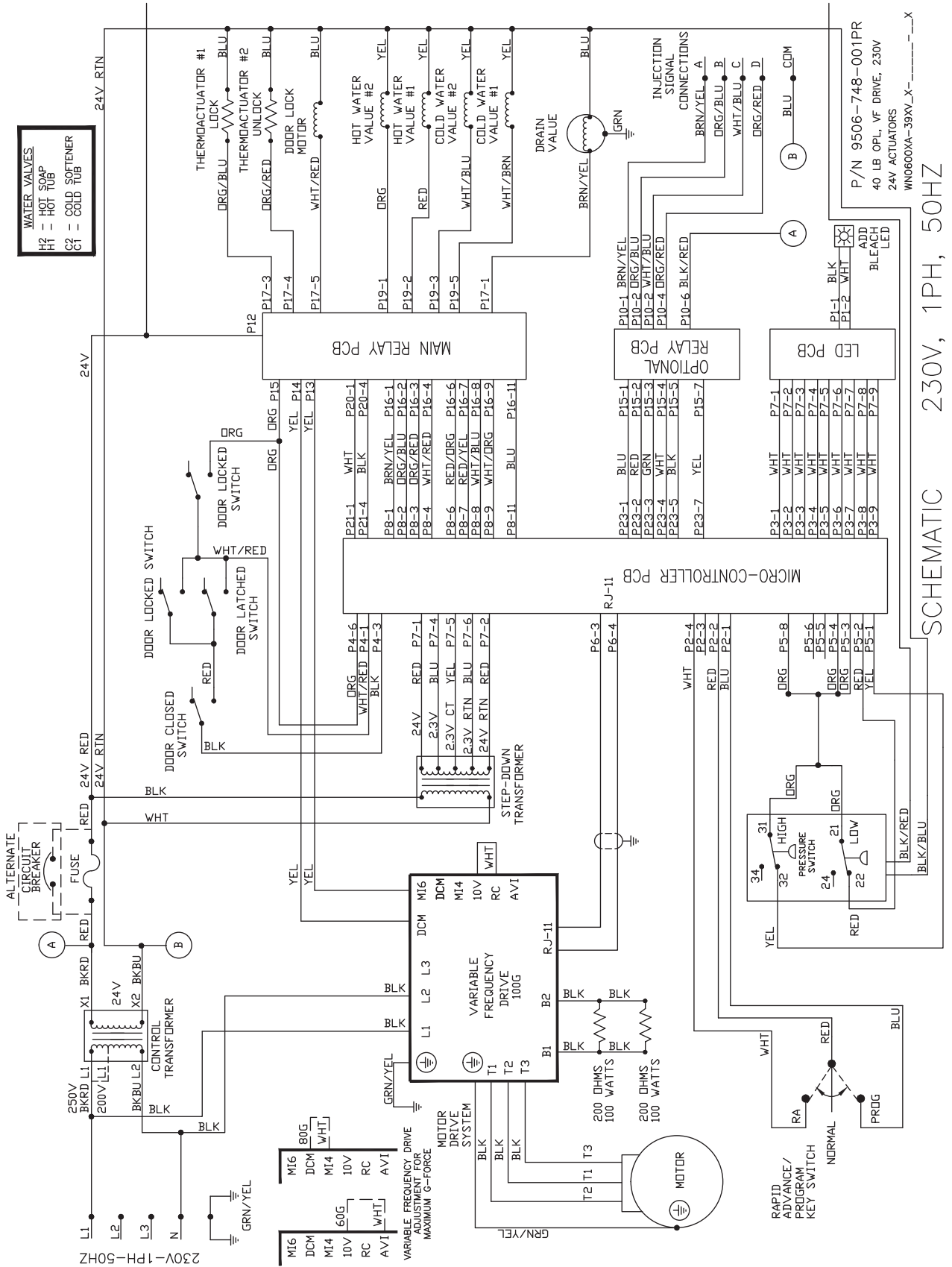

T-750 WN0750XA-39 230VAC 50Hz Wiring Diagram

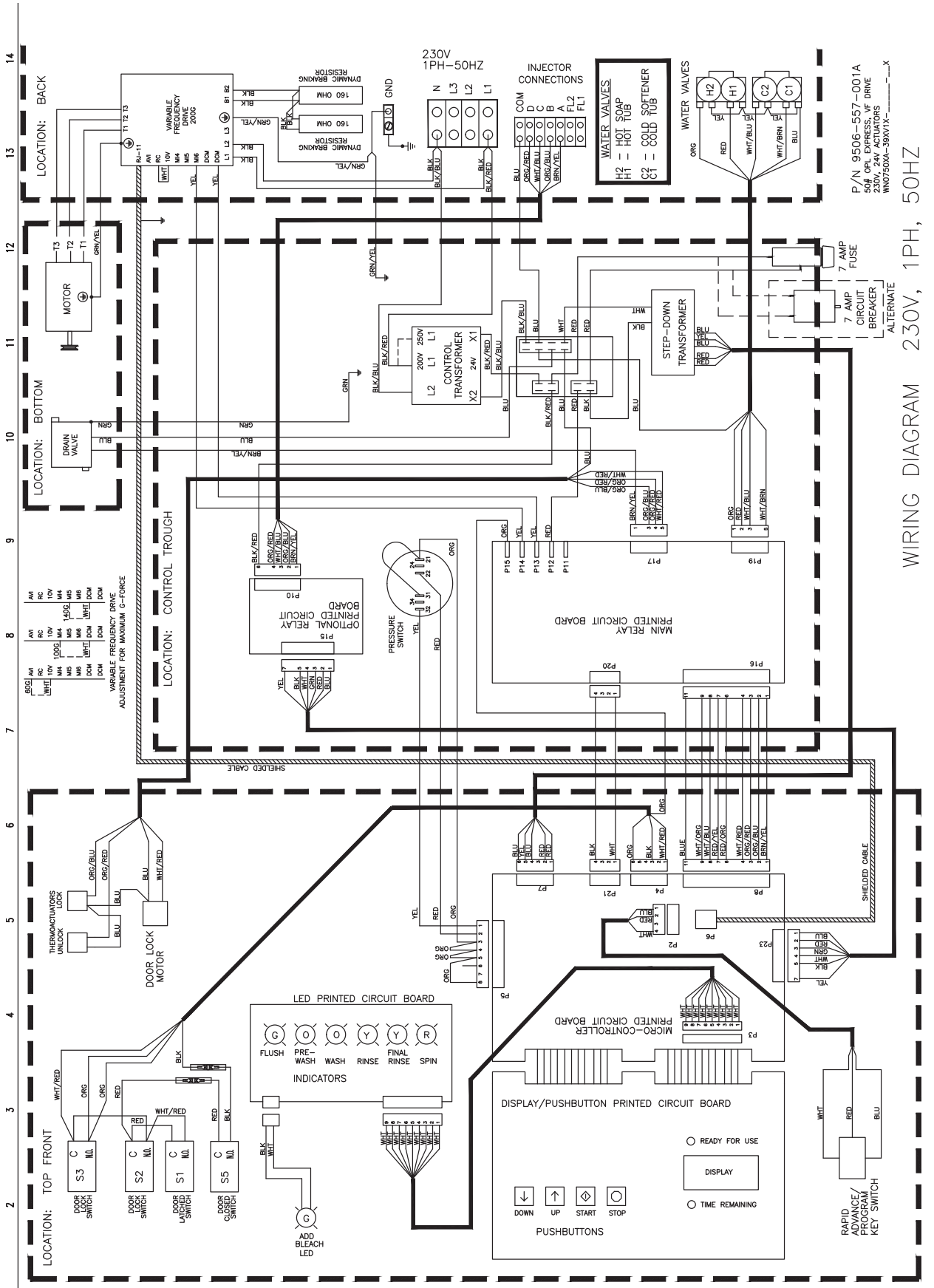

WIRING DIAGRAM 230V, 1PH, 50HZ

P/N 9506-557-001A
 50# OPL EXPRESS, WF DRIVE
 230V, 24V ACTUATORS
 WN07500A-39W1X-...X

T-750 WN0750XA-39 230VAC 50Hz Wiring Schematic

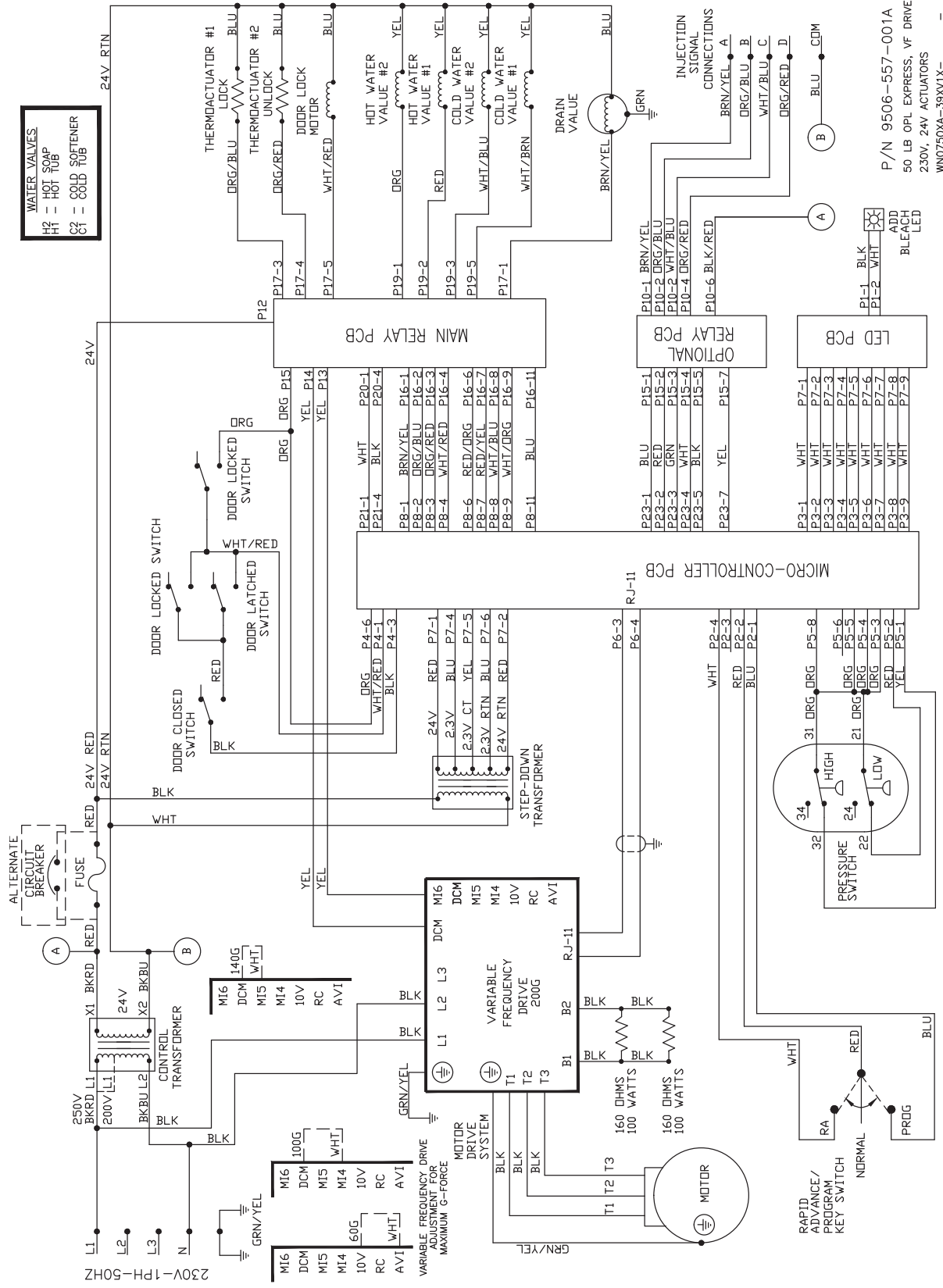

SCHEMATIC 230V, 1PH, 50HZ

T-900 WN0900XA-39 230VAC 50hz Wiring Diagram

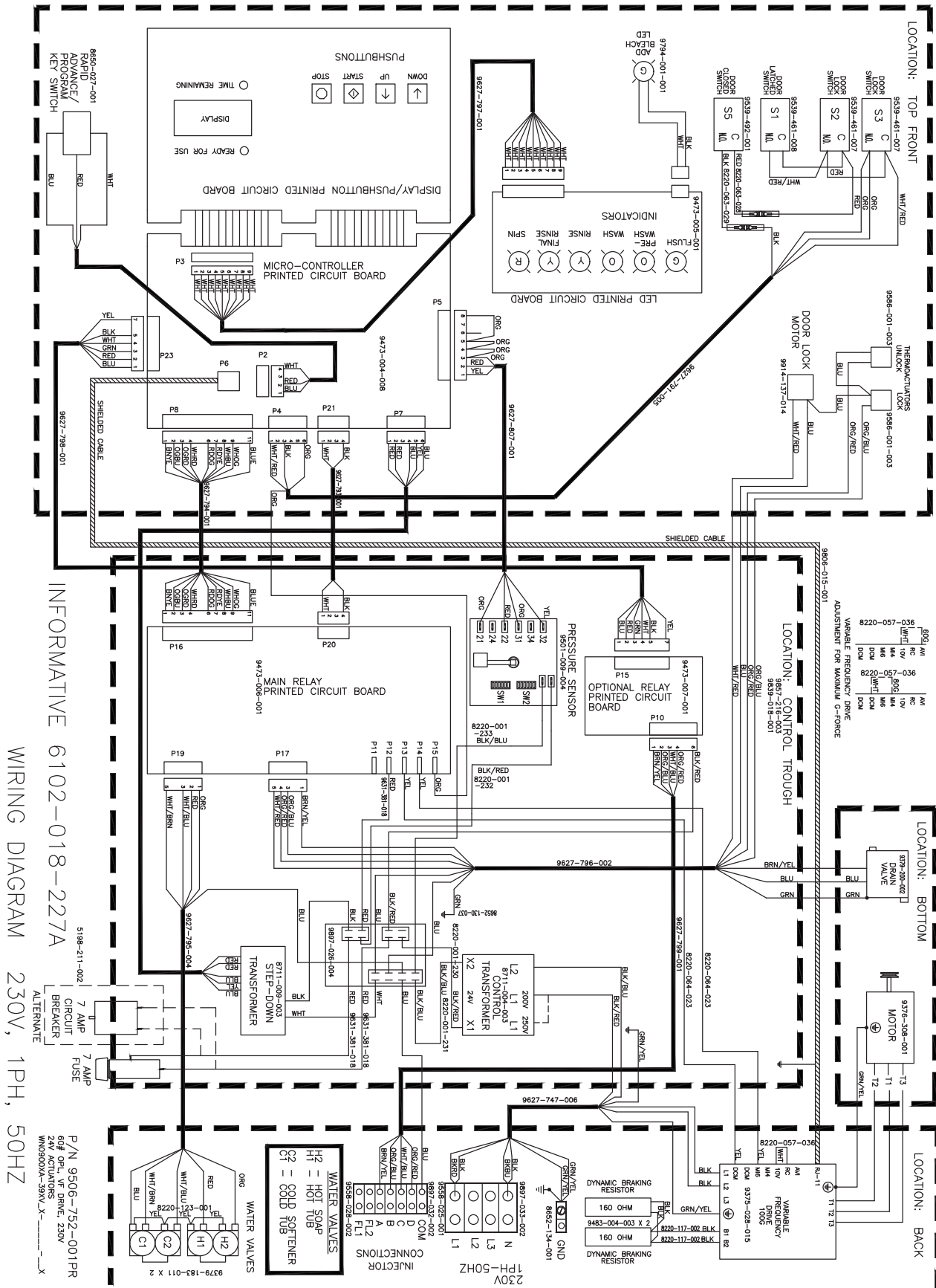

WIRING DIAGRAM 230V, 1PH, 50HZ

T-900 WN0900XA-39 230VAC 50Hz Wiring Schematic

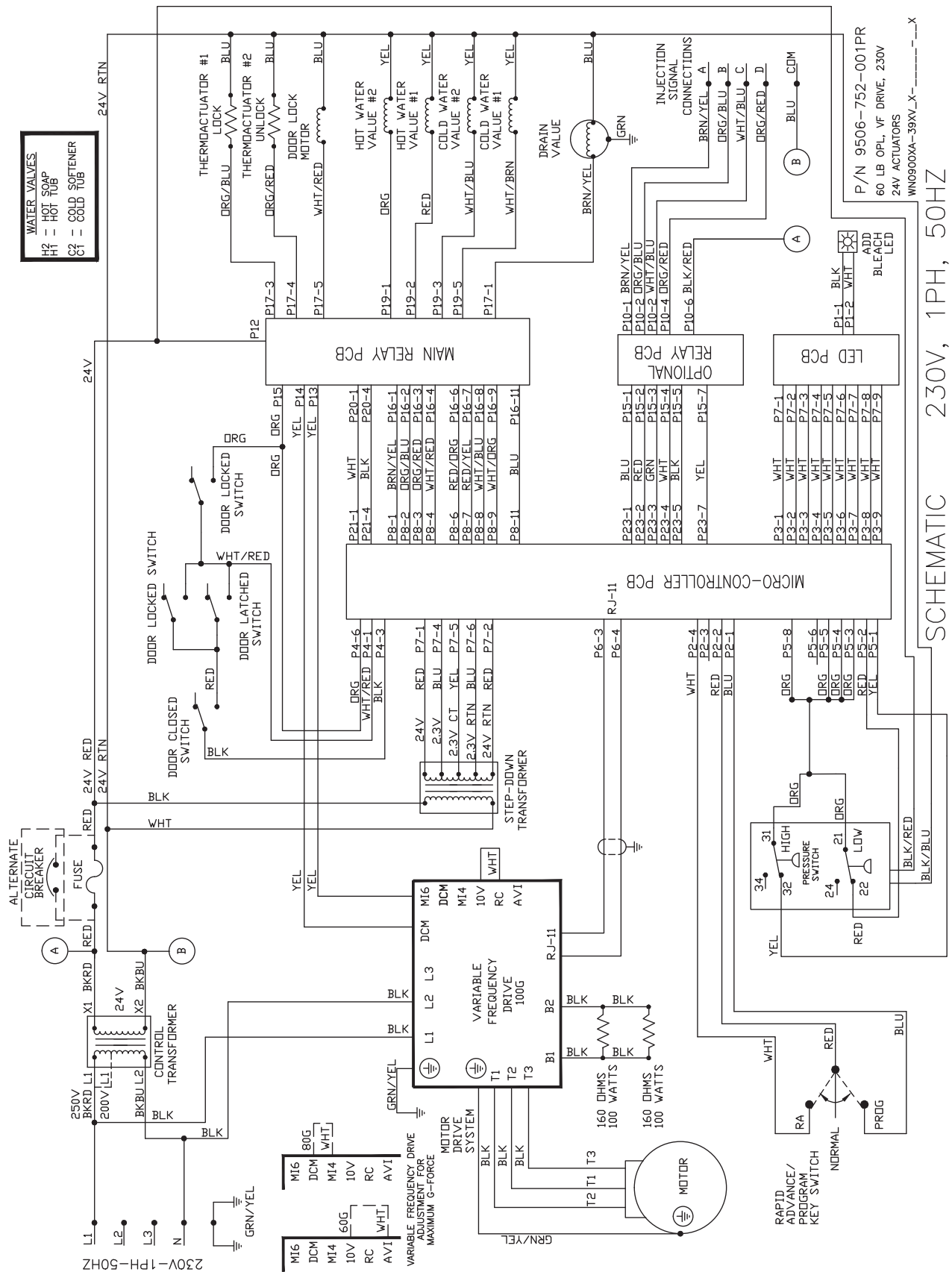

SCHEMATIC 230V, 1PH, 50HZ

T-950 WN0950XA-39 230VAC 50Hz Wiring Schematic

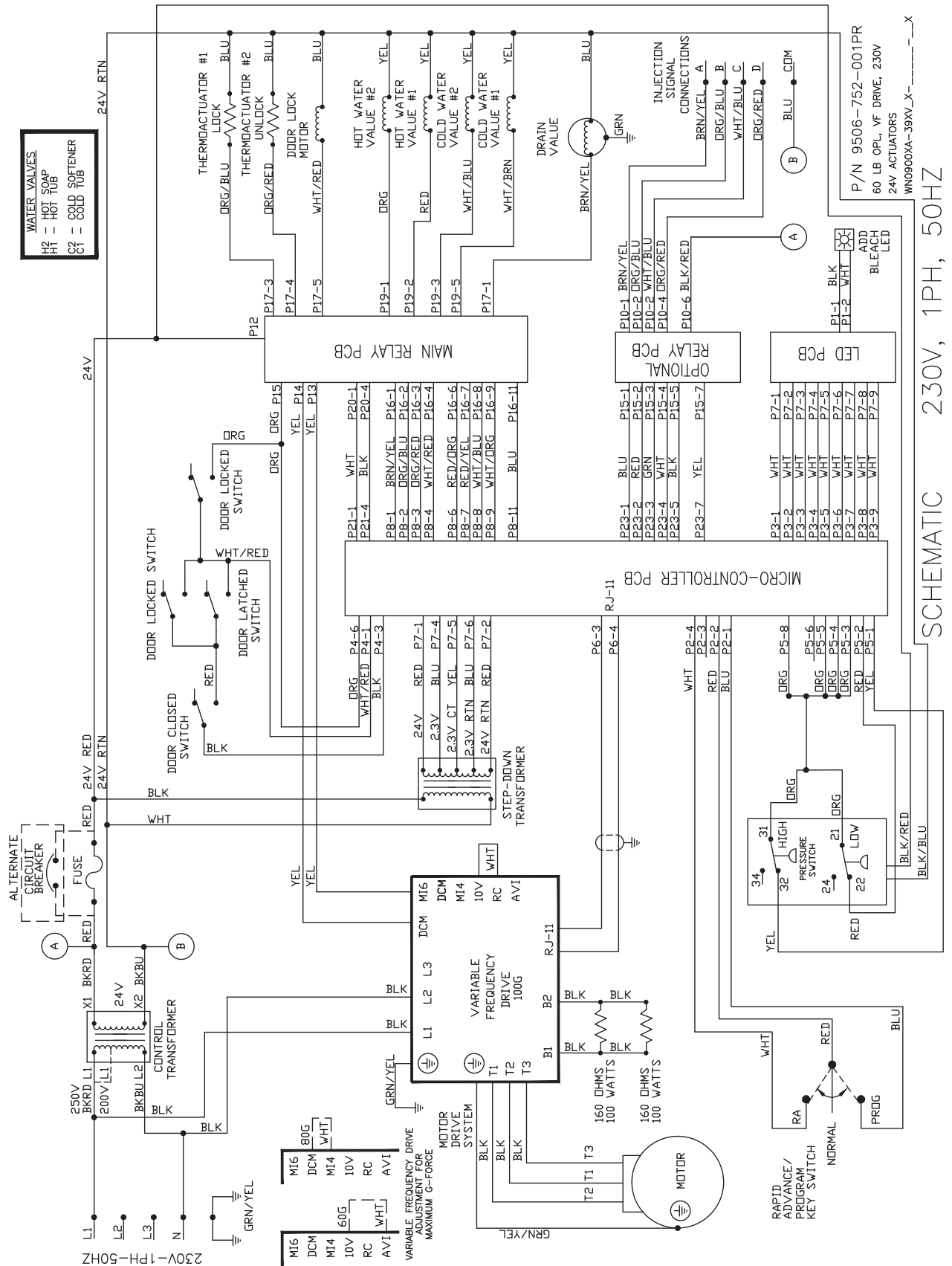

T-1200 WN1200XA-39 230VAC 50Hz Wiring Diagram

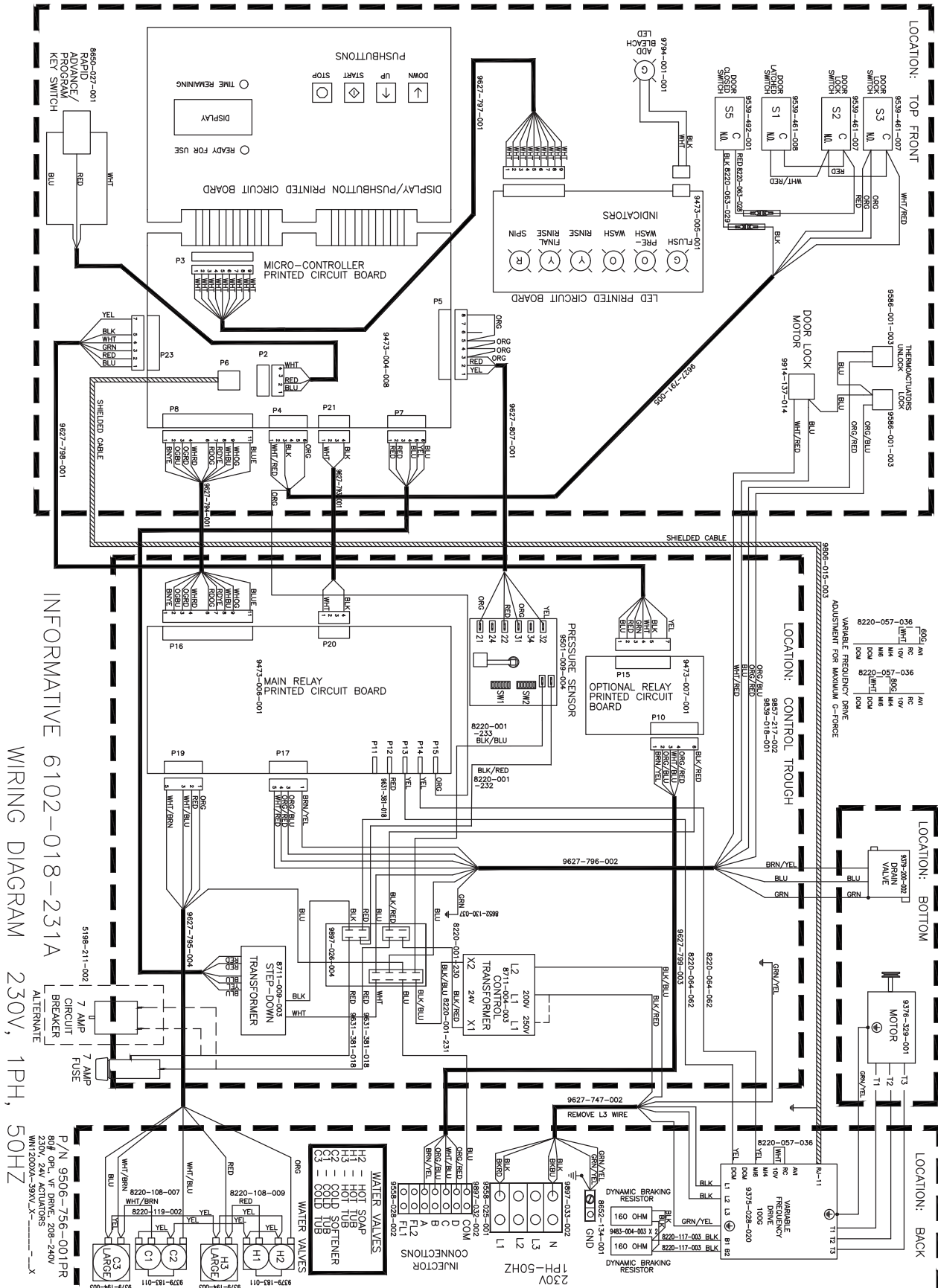

INFORMATIVE 6102-018-231A
WIRING DIAGRAM 230V, 1PH, 50HZ

T-1200 WN1200XA-39 230VAC 50Hz Wiring Schematic

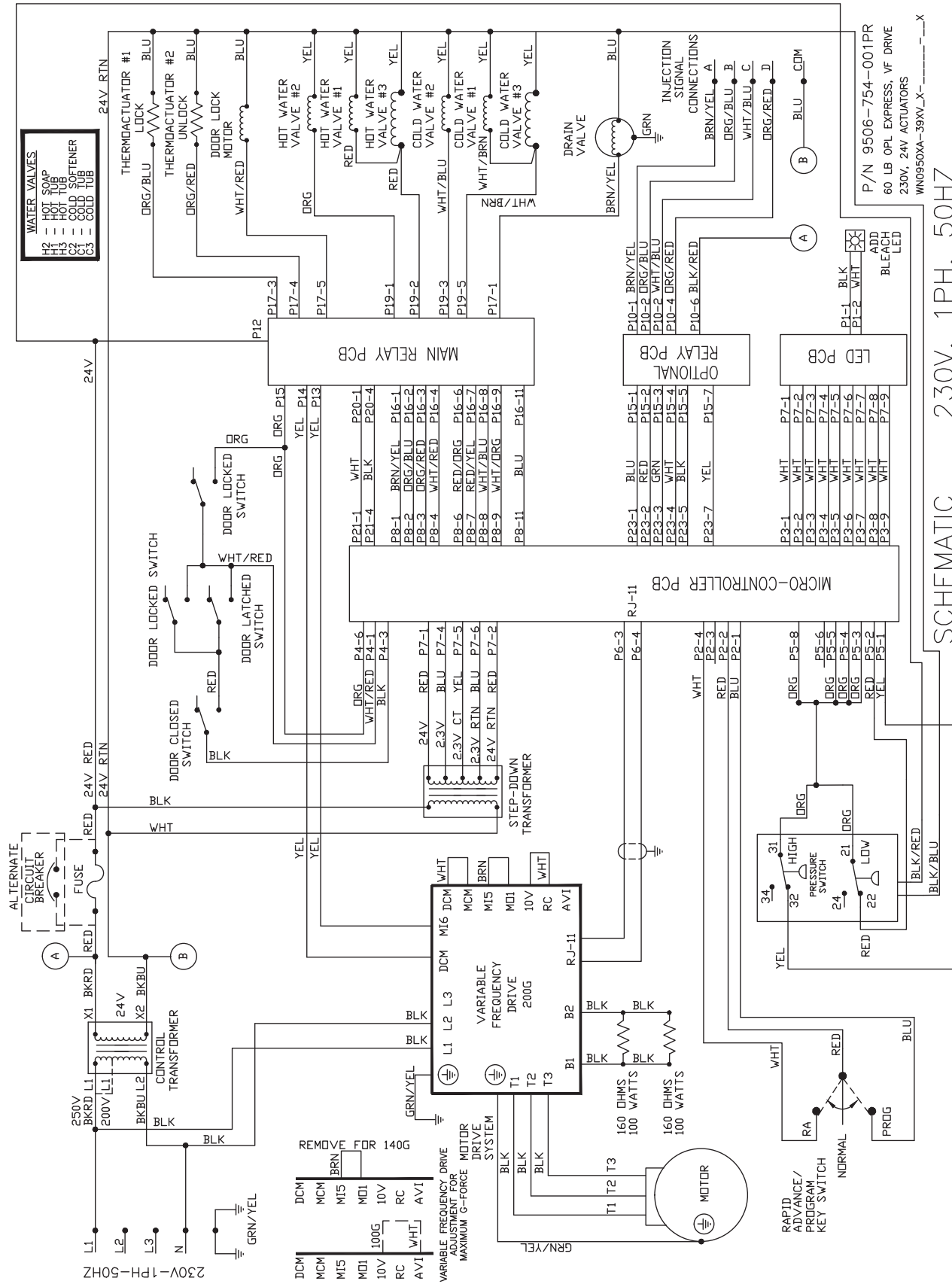

SCHEMATIC 230V, 1PH, 50HZ

P/N 9506-754-001PR
60 LB OPL EXPASTORS, VF DRIVE
230V, 24V ACTUATORS
WN0950XA-39XV_X-_____X

T-1450 WN1450XA-39 230VAC 50Hz Wiring Diagram

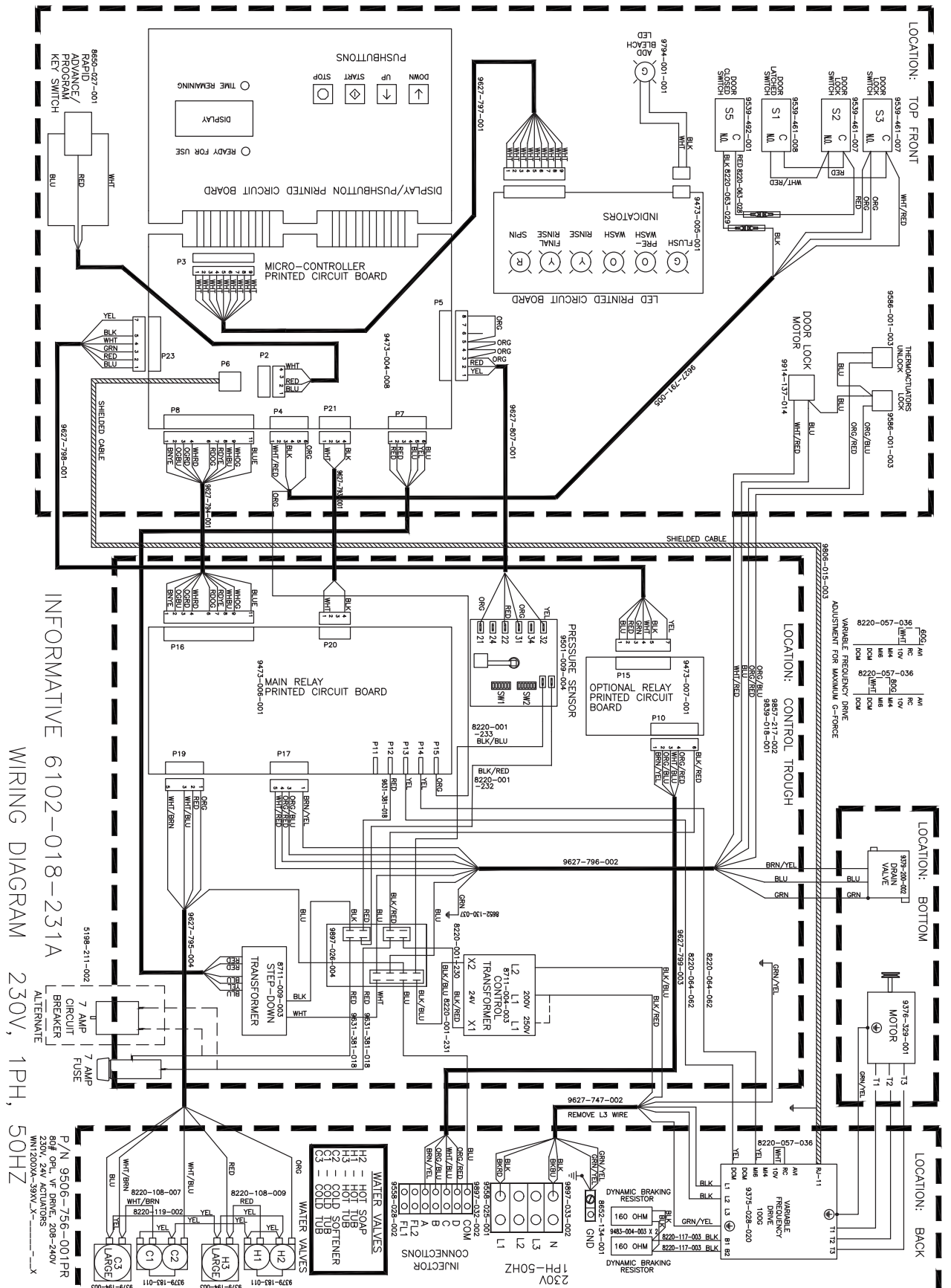

T-1450 WN1450XA-39 230VAC 50Hz Wiring Schematic

