



# Section: 10

## Washer Parts

---

## Kits, Assemblies, & Common Parts

Description	Part Number
Kit - Door Lock Assy. & Cam, replaces 9885-024-001	9732-347-001
Kit - Door cam replacement	9732-346-002
Kit - Locking Pawl replacement	9732-346-001
Kit - 8650-012-003 Lock with spacer	9732-344-001
Kit - 3" Drain valve seal replacement	9732-327-001
Drain Valve 3"	9379-202-001
Water Valve	9379-183-013
Diaphragm	9118-049-003
Electronic Pressure Switch	9732-315-001
Braking Resistors	9483-004-003
Transformer	8711-004-004
Control Board	9473-010-001
Data Cable	9806-015-002
Door Lock Gear Motor Assembly	9892-017-002
Door Lock Latching Assembly	9885-024-001
Door Handle	9244-091-001
Door Switch	9539-492-001
5/16 Hex Screw	9545-008-026
Belt	9040-076-008
Door Glass Gasket	9206-431-001

## SWD Accessories T-750

Key	Description	Part Number	Qty
*	Hose, Water Supply 5/8" I.D. x 48"	9990-027-013	2
*	Washer, Inlet Hose (furnished)	8641-242-000	2
*	Strainer, Inlet Hose (furnished)	9565-003-001	1
*	Sealing compound	8538-151-002	1
*	TORX#20	8545-051-002	1
*	Flow Restrictors (in dispenser )	9475-002-003	3
*	Battery 3V Lithium (used on Control PCB)	8612-001-001	1
*	OPL Bearing & Seal Kit	9732-219-007	1
*	Mode Light Support	9635-022-001	1

## Wiring Harnesses Parts

Key	Description	Part Number	Qty
1	Add Bleach Light, (Wiring Harness included)	9794-001-001	1
2	Wiring Harness, Door Lock P15/P4	9627-816-003	1
3	Wiring Harness, Optional Relay Board (Soap Injection)	9627-835-001	1
*	Wiring Harness, Optional Relay Board to Soap Injection terminal block	9627-799-001	1
4	Wiring Harness, Drain,Thermo,Door Gear Motor P17	9627-820-002	1
5	Data Cable	9806-015-002	1
6	Wiring Harness P20/P21	9627-818-002	1
7	Wiring Harness P8/P16	9627-819-001	1
8	Wiring Harness Water Valve/P19	9627-795-004	1
9	Wiring Harness LED PCB	9627-821-001	1
*	Wire Yellow Jumper (water valve)	8220-123-001	1
*	Harness Power Terminal Block	9627-747-003	1
10	Harness-Extention, Transformer	9627-826-001	1
12	Harness-P5/Pressure Switch	9627-807-002	1
*	Circuit Breaker 7 AMP	5198-211-002	1
*	Wiring label-schematic	9506-800-001	1

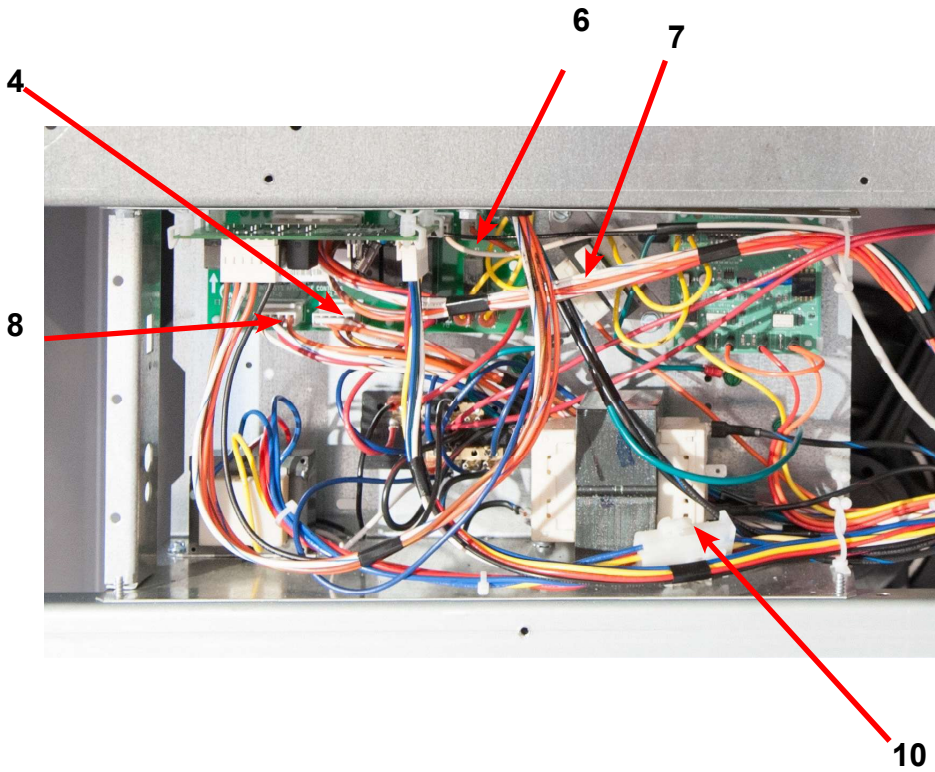
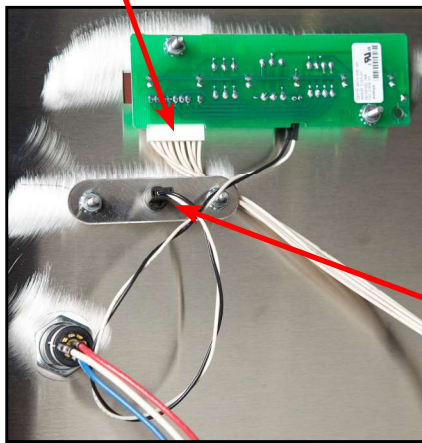
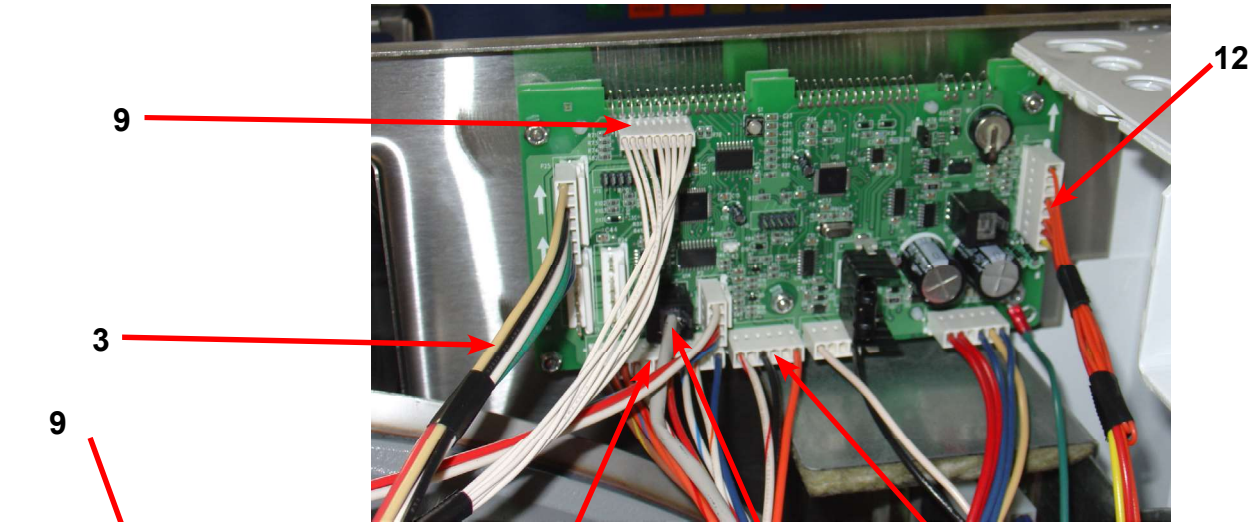

# WNS 750 Rear View Access Parts Group Part #

Key	Description	Part Number	Qty
1	Drive Motor, 3 Phase (Inverter duty)	9376-329-001	1
2	Rod, Motor Mtg	9497-222-004	1
3	Motor Bushing (Rubber)	9053-082-001	2
*	Clamp-Worm, 316SS, 1.5"	8654-117-019	2
4	Spring, Belt Tension	9534-151-000	1
*	Chain, Belt Tension	9099-012-003	1
*	Bolt, Eye (1/4"-20x21/2")	9545-055-001	1
*	Nut, 1/4 Elastic Stop	8640-414-003	1
*	Pulley, Motor	9453-179-001	1
*	Bushing-split taper	9053-077-001	2
*	Screw-Motor pulley 1/4 20x1	9545-018-024	1
5	Pulley, Driven	9453-173-002	1
*	Screw 5/8-11x2"	9545-060-004	1
*	Lockwasher 5/8"	8641-582-018	1
*	Washer, Flat 5/8x2 1/4"	8641-581-032	2
6	Drive Belt	9040-076-008	2
7	Channel, Rear	9081-180-001	1
*	Screw	9545-008-026	4
*	Nut, Spring	8640-399-007	4
*	Hose, Overflow to drain	9242-449-003	1
*	Clamp, Hose overflow to drain	8654-117-018	2
8	Hose, Overflow Vent Top	9242-463-005	1
*	Clamp, Hose Vent	8654-117-008	1
9	Vacuum Breaker ALL	9610-001-001	1
10	Bracket, Vacuum Breaker	9029-275-001	1
*	Vacuum Breaker Cap (Red)	0935-135-002	*
11	Screw, 12B x 1/2	9545-008-026	2
12	Screw, 10ABX x 1/2	9545-048-001	2
*	Plastic Plug 7/8" Electrical Connection	9456-041-006	1
13	Panel Assy., Back	9454-928-001	1
*	Screw Panel Mtg.#10Bx1/2"	9545-008-026	11
*	Screw Panel Mtg.#1/4Bx3/4"	9545-030-002	3
*	Nut, Spring	8640-399-004	8
14	Hose, Pressure Switch	9242-175-008	1
*	Clamp, Pressure Switch Hose	8654-117-015	1
*	Anchor-wire tie	9004-007-001	1
*	Strap-tie adjustable	9544-040-001	1
15	VFD Delta "E" drive 208-240 volt	9375-028-025	1
*	VFD Cooling Fan	9189-013-001	1
16	Braking resistors (160 ohm)	9483-004-003	2
17	Bracket assembly (drive mounting)	9985-119-002	1
*	VFD, MS300, V4	9375-036-019	1
*	VFD Cooling Fan	9189-016-001	1
*	Data Cable, MS300, V4	9806-026-003	1

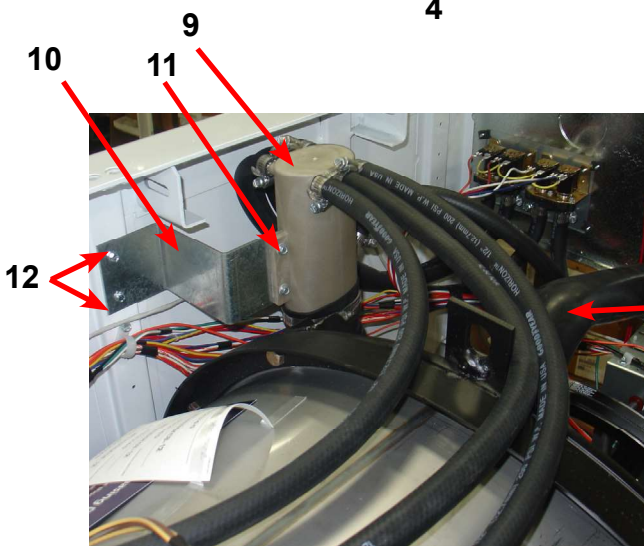
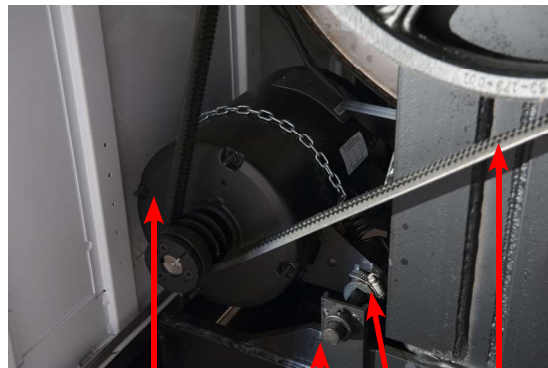
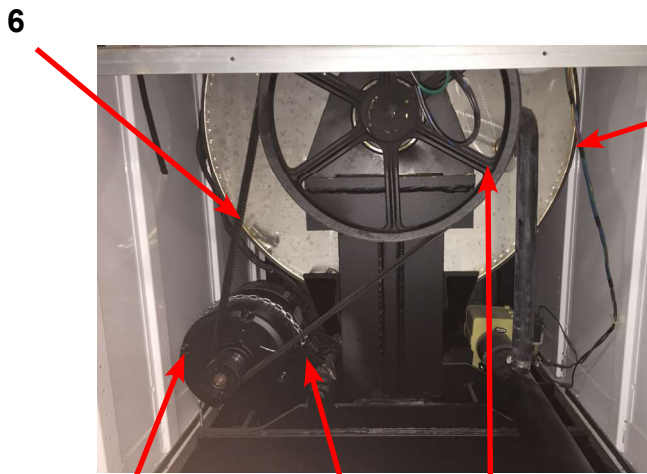

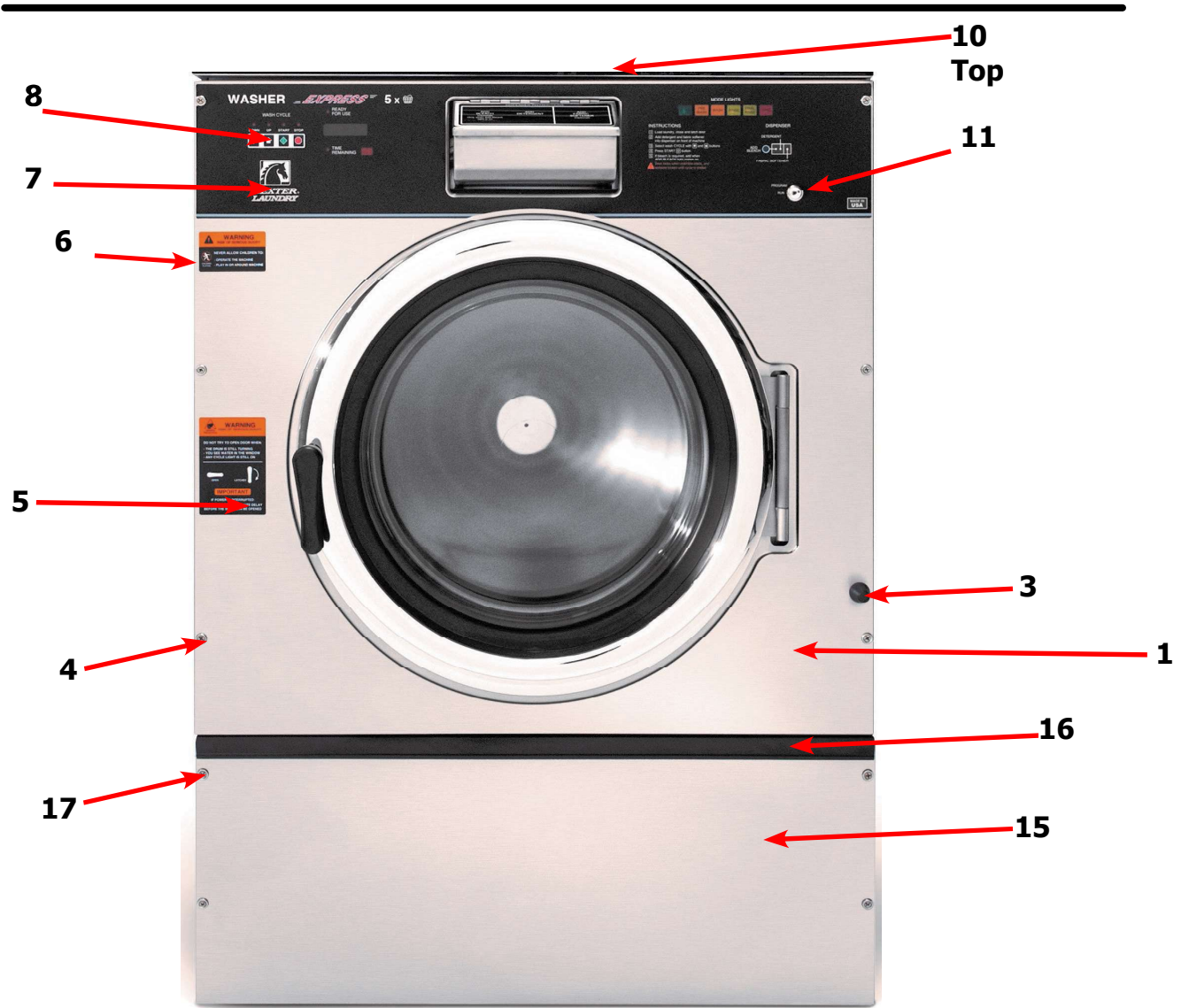

## Cabinet and Front Panel Group

	Description	Part Number	Qty
*	Panel, Right Side-Painted	9989-574-002	1
*	Panel, Left Side - Painted	9989-575-002	1
*	Strap assy-studs	9966-017-001	2
*	Strap assy-studs	9966-019-001	2
*	Shim-Side Panels	9552-046-001	2
*	Nut-hex 1/4-20unc,2b	8640-414-006	10
1	Panel Assy, Front	9989-579-001	1
*	Trim Edge Protector	9578-092-005	1
3	Bumper Loading Door	9051-055-001	1
4	Screw, 10bx1 3/4	9545-008-014	6
*	Washer Finish	8641-585-001	6
*	Nut, Spring-To Front Panel	8640-442-001	10
5	Label, Door Opening, Black	8502-757-001	1
6	Label, Risk of Injury, Black	8502-759-001	1
7	Nameplate Decal, Control Panel, Black	9412-234-001	1
8	Button, Push Control, Black	9035-062-003	1
10	Panel Top, Front, Painted	9989-576-002	1
*	Screw, Hex, #10B x 1/2	9545-008-026	12
*	Cover Top Rear	9074-367-001	1
*	Screw, Hex, #10B x 1/2	9545-008-026	4
11	Lock-Run/program w/harness	8650-027-001	
12	Soap Dispenser Assembly, Complete (Does not include lid)	9807-087-001	1
*	Soap Box mounting Gasket	9206-425-001	1
13	Lid Assembly soap box	9987-104-001	1
*	Lid screws #10-32x1/2 SS	9545-012-017	2
*	Nut Hex Elasticstop #10-32 SS	8640-413-006	6
*	Bracket Soap box mounting	9029-122-002	1
*	Softener siphon tube (plastic)	9574-252-002	1
*	Flow restrictors	9475-002-003	3
14	Label, Dispenser Instructions, Black	8502-756-001	1
15	Door, Lower Service	9108-137-001	1
16	Handle, Lower Service Door	9244-086-003	1
17	Screw, 10bx 1 3/4	9545-008-014	4
*	Washer Finish	8641-585-001	6



## Cylinder, Seals & Bearings Part # by Model

Key	Description	T-750	QTY
1	Bearings and Seal Kit	9732-219-007	1
*	Housing, Bearing- Assembly (items #2-#6)	9803-187-001	1
2	Housing, Bearing	9241-181-004	1
3	Bearing, (Small)	9036-159-006	1
4	Bearing, Front (Large)	9036-159-005	1
5	Spacer, Bearing	9538-170-001	1
6	Ring, Bearing Retainer	9487-238-004	1
8	Seal, Small V85A	9532-140-007	1
9	Seal, Large V140A	9532-140-008	1
10	Ring, Seal Mounting	9950-052-001	1
11	Tub Back Mating Ring	9487-261-004	1
11G	Mating Ring Guard Shield	9487-266-001	1
12	Bolt, Tub End of Bearing Housing (7/16-14x1), Bolt from inside Tub	9545-059-004	6
13	Washer, Flat	8641-581-034	6
14	Screw-Hex Cap, 3/4"-10 x 3" (Bearing Housing to Frame)	9545-057-002	6
15	Washers Spherical 3/4 (Male half) (Bearing Housing to Frame)	8641-588-001	6
16	Washers Spherical 3/4 (Female half) (Bearing Housing to Frame)	8641-588-002	6
17	Nut 3/4"-10 (Bearing Housing to Frame)	8640-418-003	6
18	Pulley, Driven	9453-173-002	1
*	Tolerance Ring	9487-234-004	1
*	Screw, 5/8"-11 x 2"	9545-060-004	1
19	Washer-Flat .675x2-1/2x1/4	8641-581-032	1
20	Lockwasher-Exttooth, 5/8	8641-582-018	1
21	Bolt, 5/8-11x1 1/2	9545-060-004	1
22	Tub & Cylinder Assy	9869-036-001	1
23	Cylinder Assy	9848-136-002	1
*	Tub Front	9974-011-002	1
*	Gasket, Tub Front	9206-421-002	1
*	Ring Assy, Tub Mtg-Front Clamp	9950-055-001	1
*	Bolt, Top Front Ring 3/8"-16 x 3"	9545-029-009	1
*	Nut 3/8"-16	8640-415-001	1

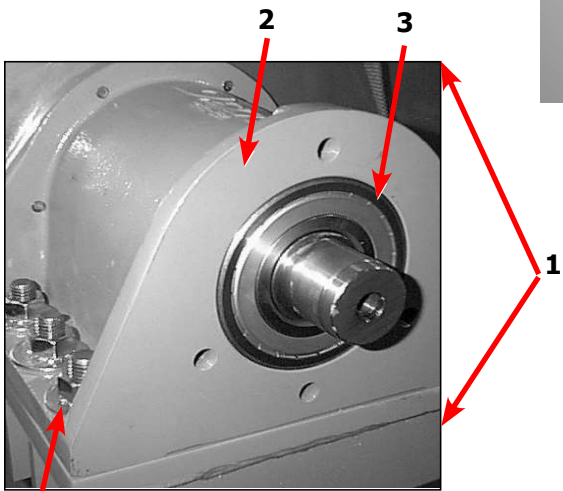
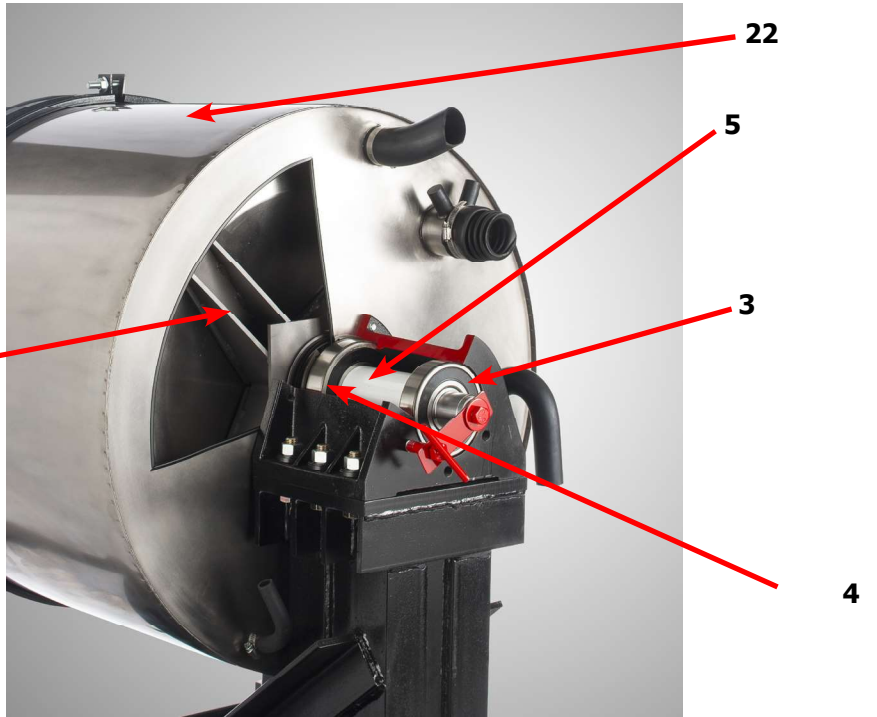
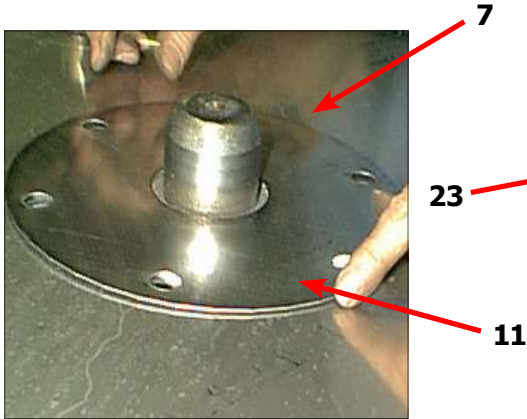
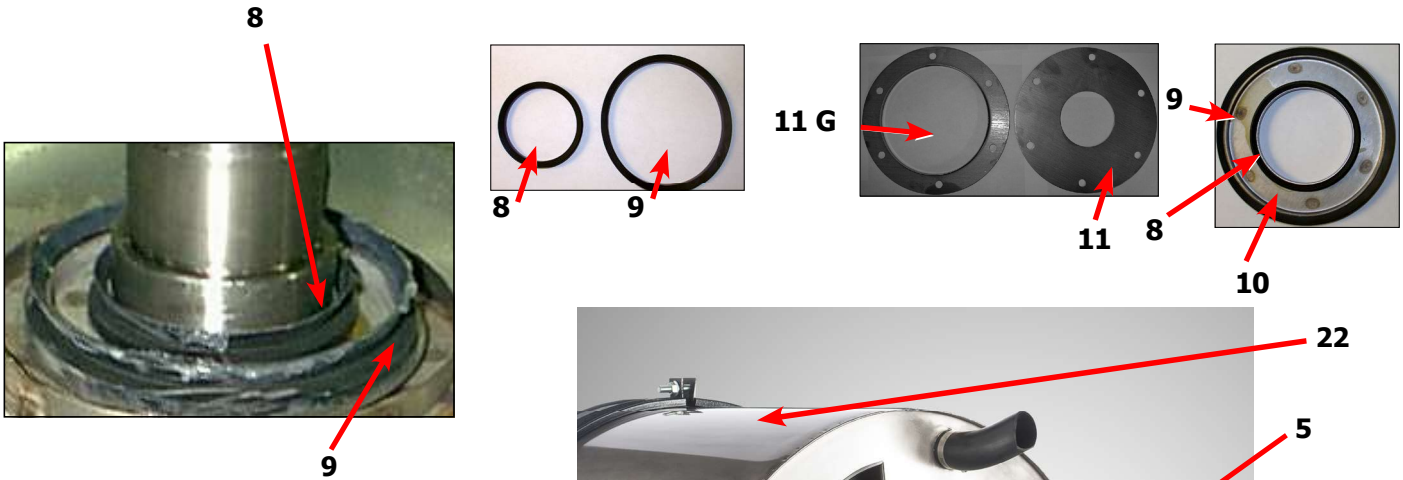

14,15,16,17

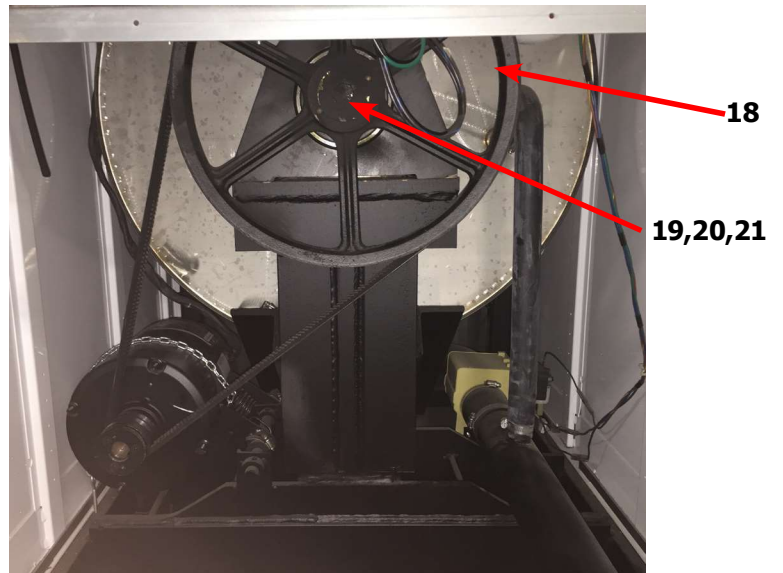

## Door Lock Assembly (continued)

Key	Description	Part Number	Qty
33	Lock Assy, Complete (#1-22)(includes #1 thru #22)	9885-031-001	1
1	Plate Assy, Door Lock	9982-346-001	1
2	Washer, Flat	8641-581-030	1
3	Actuator, Latching Switch	9008-005-001	1
4	Pawl, Locking	9732-346-002	1
5	Washer, Spring	8641-569-003	1
6	Ring, Retaining	9487-200-004	1
7	Bracket Switch	9029-163-001	1
8	Nut, Hex 10-32 UNF	8640-413-002	2
9	Spring, Actuating	9534-364-002	1
10	Screw, Hx. 10-32 x 1"	9545-012-020	1
11	Nut, Elastic Stop 10-32	8640-413-004	2
12	Spring, Return	9534-364-001	2
13	Pin, Guide	9451-193-001	1
14	Ring, Retaining	9487-200-005	1
15	Washer	8641-581-031	1
16	Switch, Latching Sensing	9539-461-008	1
17	Shield, Switch	9550-169-003	3
18	Screw 4-40 x 5/8"	9545-020-001	2
18	Nut, Twin 4-40	8640-401-001	1
19	Switch, Locking Sensing	9539-461-007	2
20	Actuator, Switch Locking	9008-006-003	1
21	Screw 4-40 x 1 1/8"	9545-020-003	2
21	Nut, Twin 4-40	8640-401-001	1
*	Spacer Sensor	9538-182-001	*
*	Shim, Door Lock, Thin	9552-037-001	AR
*	Screw, Lock mtg 1/4"-20 x 3/4"	9545-018-014	3
*	Lockwasher 1/4" Ext tooth	8641-582-007	3

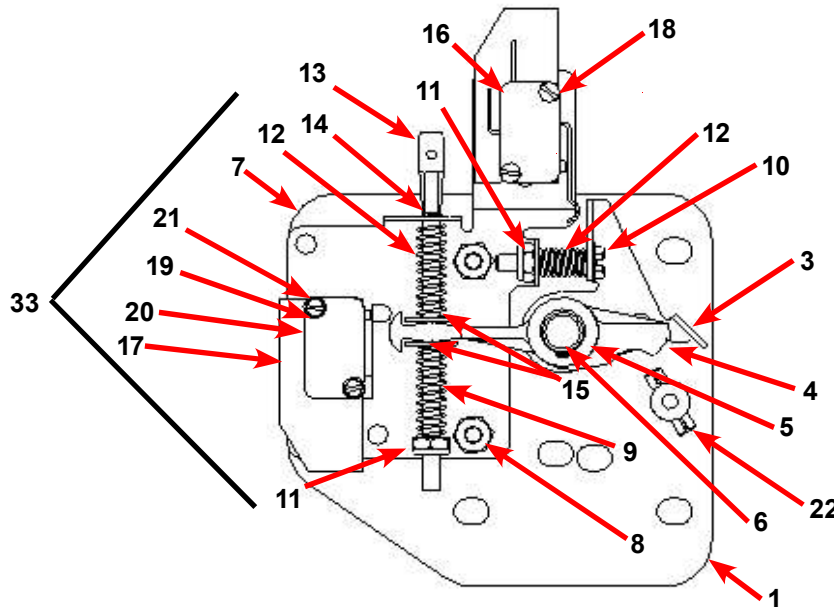

# Gear Motor Door Lock Assembly

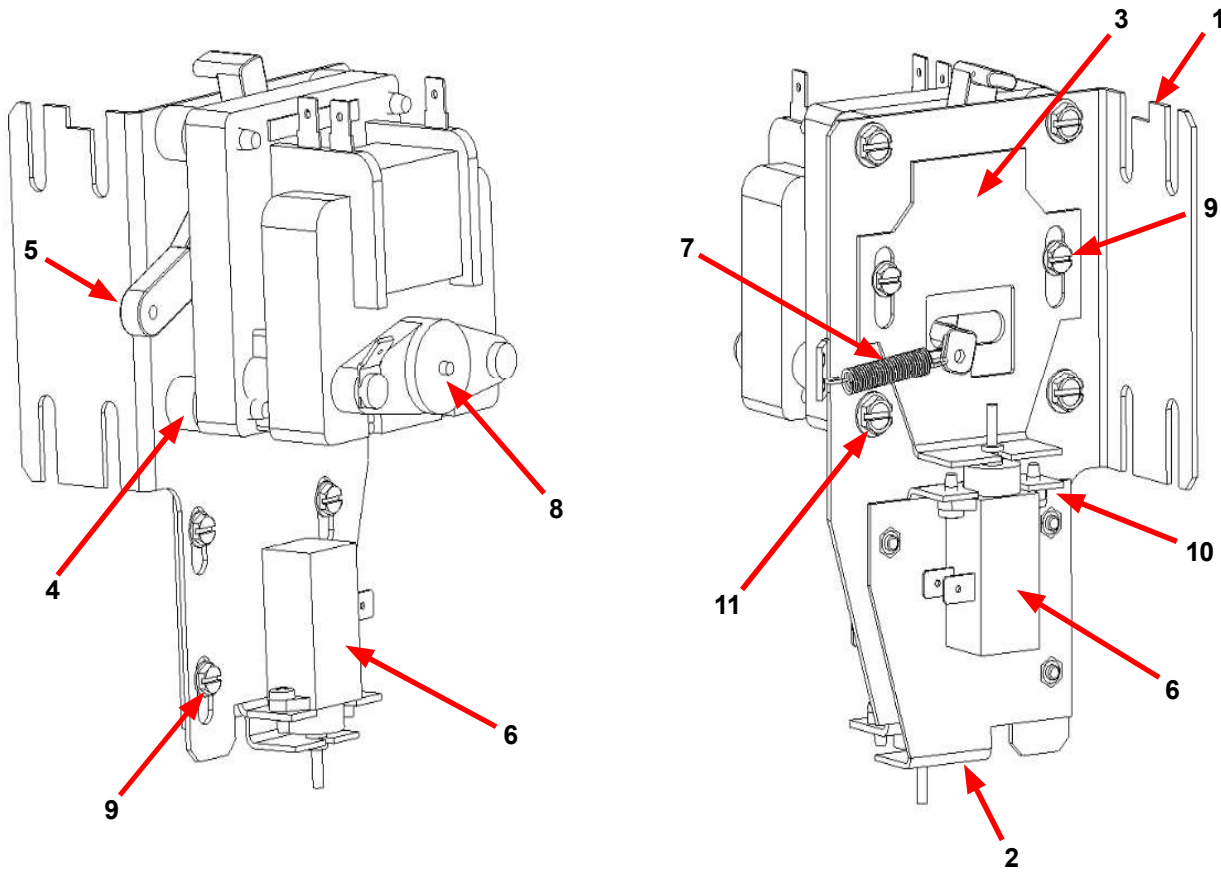

Key	Description	T-750	QTY
*	Actuator Assembly (Includes 1-10, Rod NOT included)	9892-017-002	1
1	Bracket Assy, Slide Lock Actuator	9985-199-001	1
2	Bracket Assy, Slide - Unlock	9985-196-001	1
3	Bracket Slide Lock	9029-278-001	1
4	Spacer, Plastic	9538-157-021	4
5	Arm - Door Lock	9001-063-001	1
6	Thermoactuator - Door Lock Relay 24v	9586-001-003	2
7	Spring - Extension	9534-350-001	1
8	Motor & Gear Assembly 24v	9914-137-014	1
9	Screw -HxwshrhdsIsems, 6-32 x 3/16	9545-044-003	6
10	Cross Recessed PAn Hd Tapping screw	9545-031-011	4
11	Screw hxwshdsl, 10-24 - 1.25f, ctd	9545-046-007	4
*	Rod, Door Lock	9497-231-001	1
*	Harness, Door Lock/Drain, P17	9627-816-003	1

# Large Door & Hinge Group

Key	Description	T-750	QTY
1	Door Hinge Assembly (mounts to tub front)	9955-031-001	1
*	Door Assembly Complete	9960-310-001	1
2	Door Ring 180 degree large hinge	9487-275-001	1
3	Door Gasket	9206-431-001	1
4	Door Glass Window	9635-020-001	1
*	Red Wire (Door Close Switch)	8220-063-028	1
*	Black Wire (Door Close Switch)	8220-063-029	1
5	Switch, Door Hinge Close (Plunger)	9539-492-001	1
6	Top Door Hinge Leaf	9845-006-001	1
7	Bottom Door Hinge Leaf	9845-007-001	1
8	Thrd Form Screw, Door Mtg 5/16" x 5/8"	9545-056-002	4
9	Screw, Loading Door Hinge Mtg (5/16" x3/4" ss)	9545-014-009	3
9	Lock Washer, exttooth 5/16	8641-582-009	3
*	Shim Large door	9552-043-001	1
*	Gusset side panel RH	9210-128-003	1
*	Gusset side panel LH	9210-128-002	1

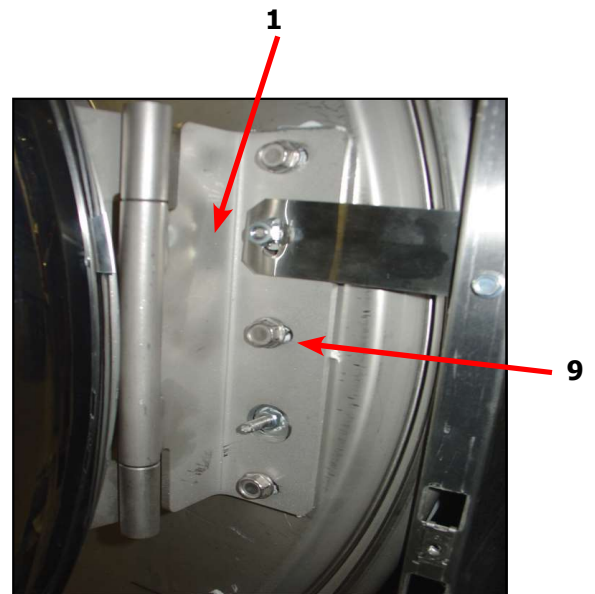

Key	Description	T-750	QTY
*	Shaft Assembly-Loading Door (11-14)	9913-136-001	1
11	Shaft, Door Locking	9537-195-002	1
12	Cam, Locking	9095-051-001	1
13	Pin, Groove (1 1/4)	9451-181-005	1
14	Pin, Groove (3/4)	9451-181-004	1
15	Spring, Lock Cam	9534-360-002	1
16	Handle, Door	9244-091-001	1
17	Pin, Door Handle (groove)	9451-181-005	1

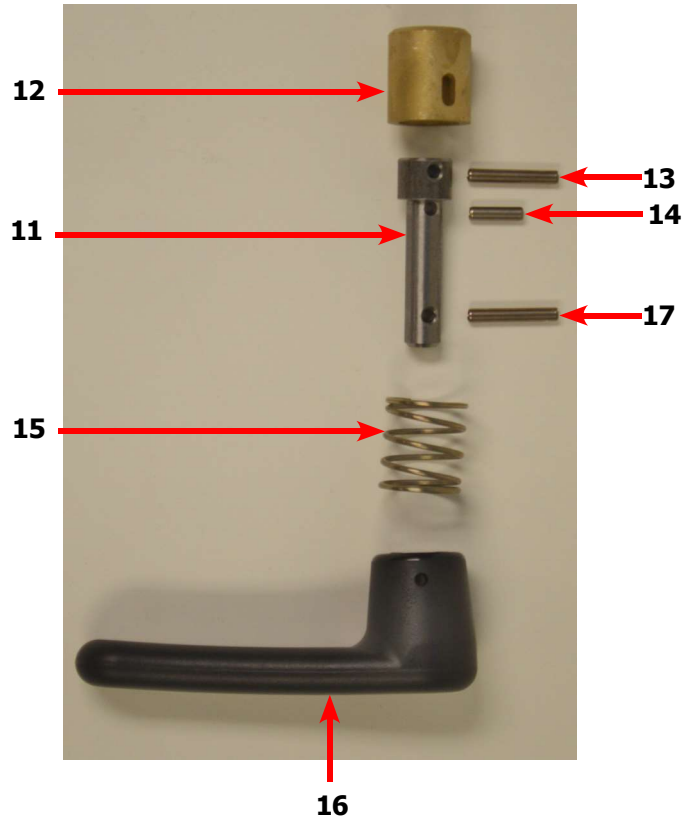
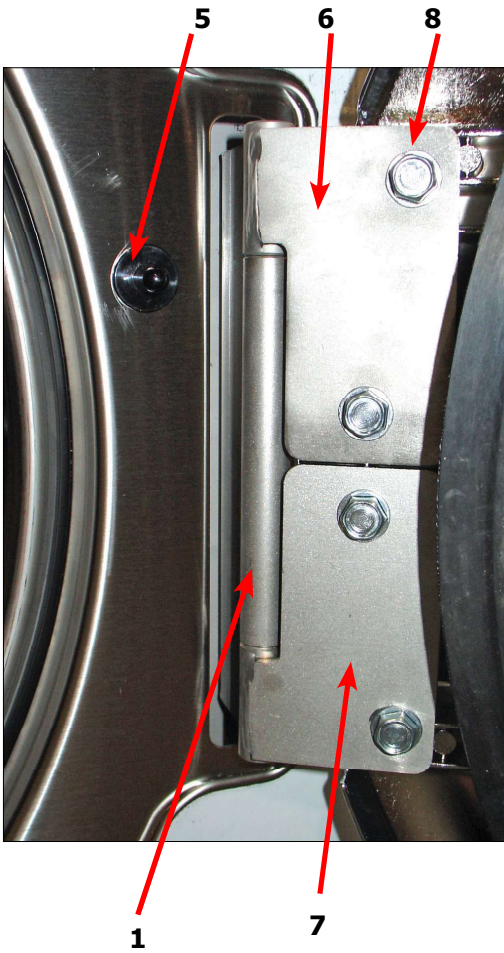

# Drain Valve Group Part # by Model

Key	Description	Part Number	Qty
1	Valve, Drain (includes #2 thru #11)	9379-202-002	1
2	Body, Valve (w/ball)	9064-072-001	1
3	Motor & Gear Train (complete)	9914-137-022	1
4	Plate, Motor Mtg	9452-538-001	1
5	Screw	8639-994-001	1
6	Spring, Drive	9534-339-001	1
7	Screw	9545-054-001	1
8	Screw	9545-054-002	1
9	Seal, V Packer	9532-134-001	1
10	Washer	8641-584-001	1
11	Pin, Main Drive	9451-196-001	1
12	Kit - Seal Replacement	9732-327-001	1

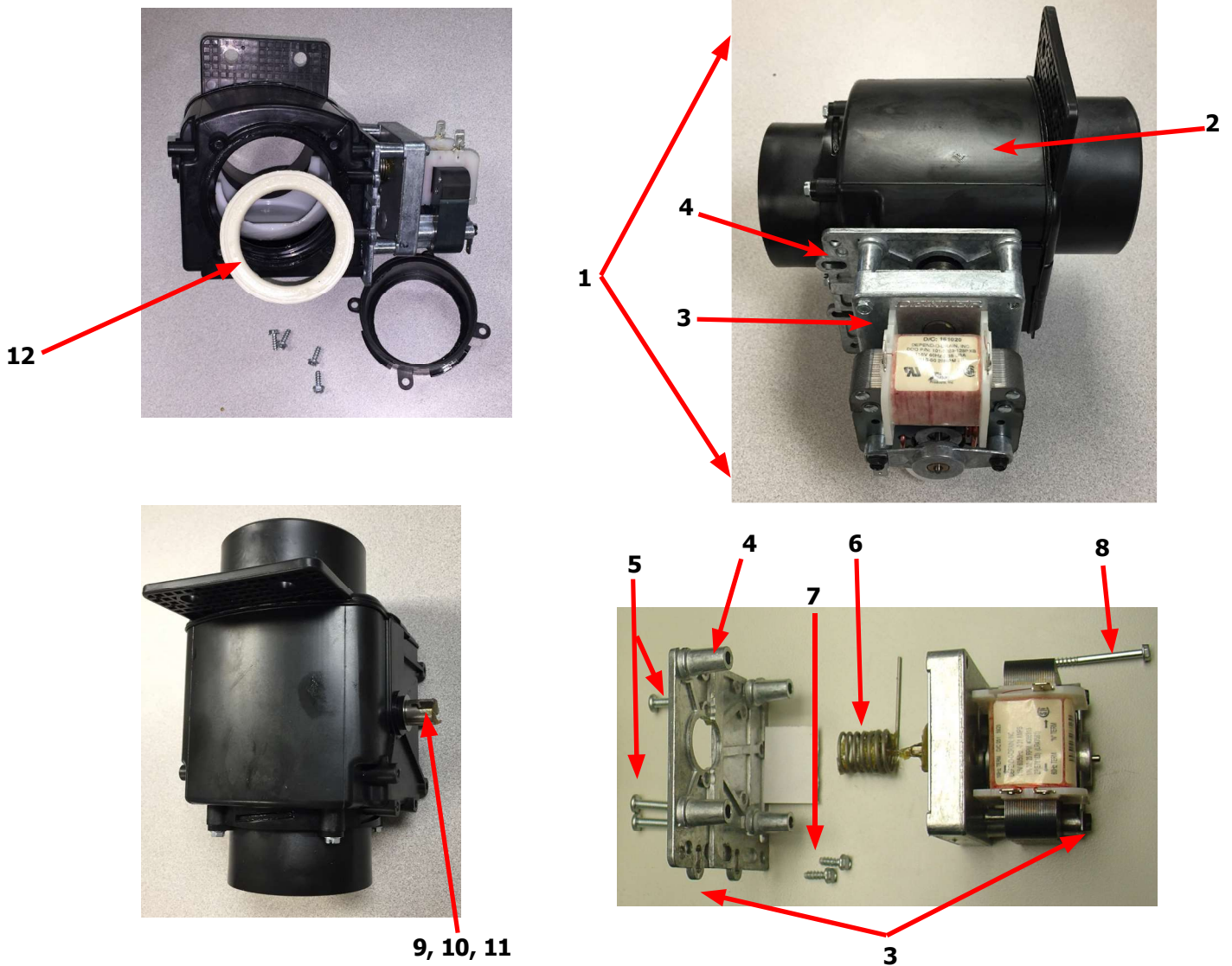

# Water Inlet Valve Breakdown

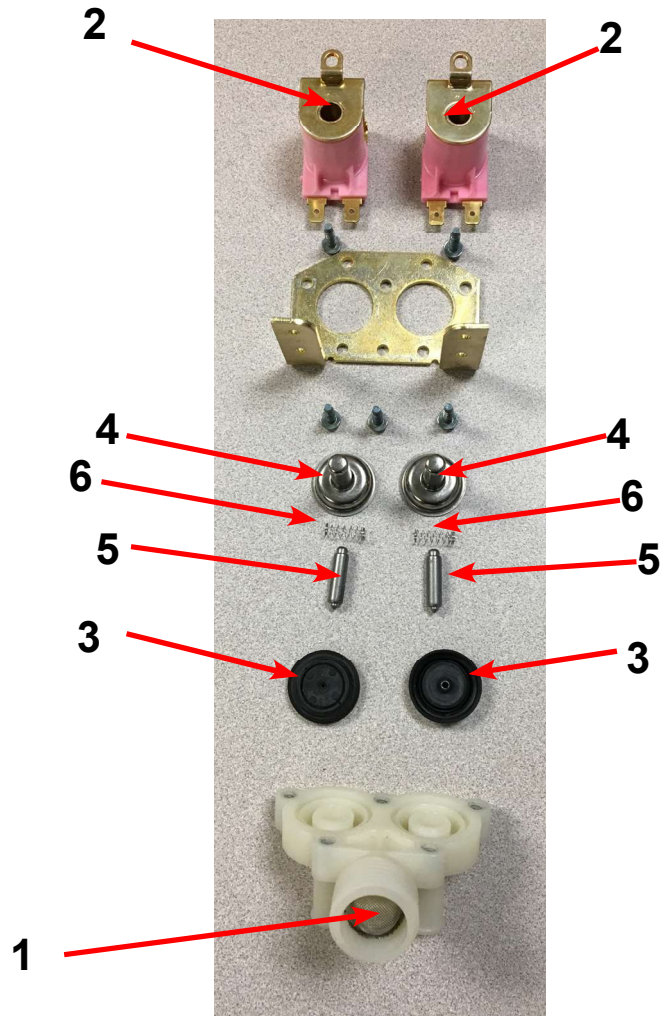

Key	Description	Part Number	QTY
*	Valve, Water Inlet (includes 1 thru 6) - <b>Invensys</b>	9379-183-013	2
1	Screen, Inlet end of valve	9555-056-001	2
2	Coil Assy., 24 V Invensys	9089-017-004	2
3	Diaphragm Invensys (EPDM)	9118-049-003	2
4	Guide, Solenoid Invensys	9211-021-002	2
5	Armature Invensys	9015-008-001	2
6	Spring, Armature Invensys	9534-298-001	2



## Chassis and Drain Part # by Model

Key	Description	T-750	QTY
1	Base Assy,Frame	9945-144-002	1
2	Outer Tub Assy	9930-171-001	1
*	Tub & Cylinder Assy	9869-036-001	1
3	Tub Front	9974-011-002	1
*	Gasket, Tub Front	9206-421-002	1
4	Ring Assy, Tub Mtg-Front Clamp	9950-055-001	1
5	Bolt, Top Front Ring 3/8"-16 x 3"	9545-029-009	1
6	Nut 3/8"-16	8640-415-001	1
7	Bolt, 1/2" -13 x 2" (Tub Mounting to Frame)	9545-017-013	2
8	Nut, Wizloc 1/2" x 13	8640-417-005	2
9	Washer, Flat 1/2"	8641-581-026	2
10	Hose, Tub to Drain Valve	9242-456-001	1
11	Clamp, Hose (Tub to Drain Valve)	8654-117-014	2
12	Valve, Drain	9379-202-002	1
*	Screw, Valve to Base 1/4Bx3/4	9545-030-002	2
*	Washer, Flat 1/4	8641-581-018	4
13	Hose, Drain Valve to Tube	9242-457-001	1
*	Clamp, Hose (Drain Valve to Tube)	8654-117-014	1
14	Tube Assy, Drain	9915-131-002	1
15	Clamp, Hose (Tube to Frame Bracket)	8654-117-014	1
*	Screw Tube (Bracket to Base 1/4Bx3/4)	9545-030-002	4
16	Hose, Overflow Tub To Drain Tube	9242-449-003	1
*	Clamp, Hose	8654-117-018	1
*	Tube, Suds overflow	9242-463-005	1
*	Clamp, Hose	8654-117-008	2
17	Hose, Pressure switch	9242-175-008	1
	Clamp, Hose	8654-117-015	1
18	Injection Assy-Soap	9883-013-001	1
*	Cap- Injector assembly	0935-127-001	

**18**

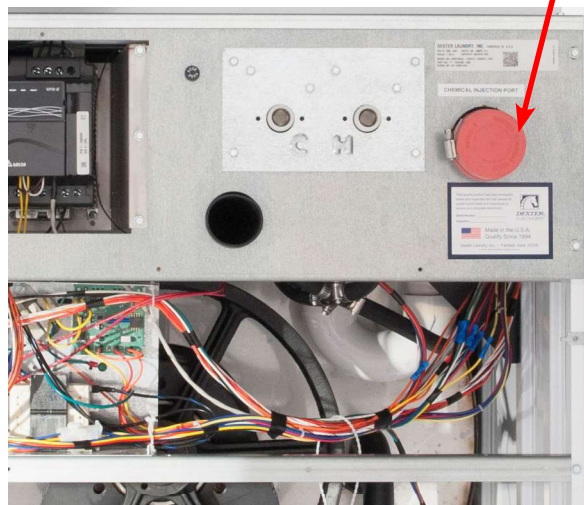

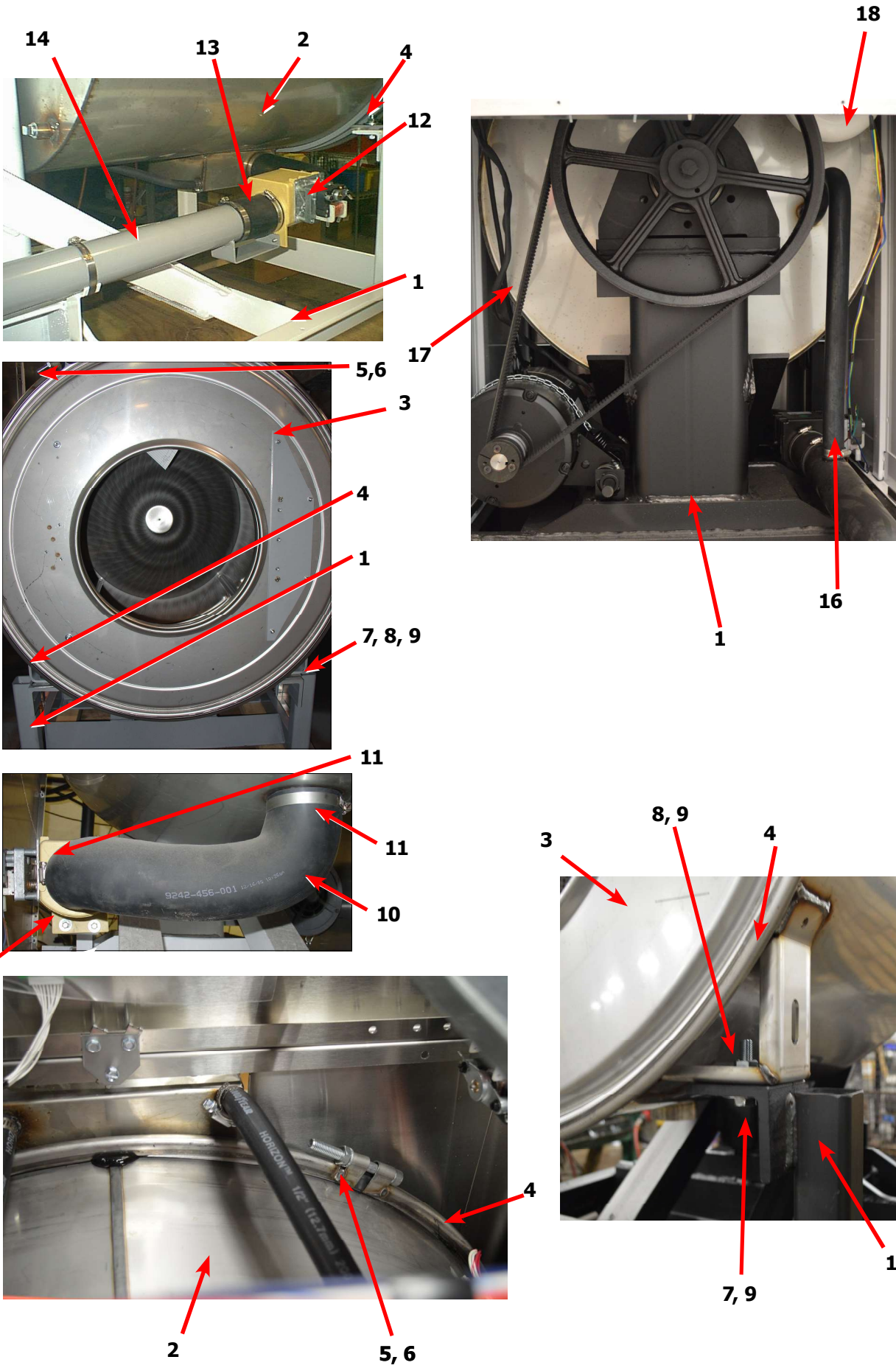

# Electrical Components, Control Trough

Key	Description	Part Number	Qty
1	Trough Assy,Controls 208-240 volt	9857-226-001	1
	Trough only	9839-018-001	1
2	Transformer, Control (208/230/60 Hz In 24 VAC Out Volts)	8711-004-004	1
*	Wire Assembly, Red 28"	8220-062-025	2
*	Screw, #10B x 1/2	9545-008-026	4
*	Lockwasher #10	8641-582-006	4
*	Wire Assembly, BLK/BLU	8220-001-231	1
*	Wire Assembly, BLK/RED	8220-001-230	1
3	Terminal Block Assy, POWER	9897-026-004	1
*	Screw, Mtg 8ABx1/2"	9545-045-012	2
*	Harness-extention, Transformer	9627-826-001	1
*	Screw, 8B x 1/4"	9545-045-001	2
*	Lockwasher-External Tooth, #6	8641-582-005	2
*	Wire Assembly, P12, Red 7"	9631-381-018	1
4	PCB assembly Relay Main	9473-006-001	1
*	PCB support 3/8 edge Holding	9548-285-001	10
*	Wiring Harness, Door Lock P15/P4	9627-816-003	1
*	Wiring Assembly Yel. 32" P14 & P13	8220-064-023	2
5	Wiring Harness, Drain,Thermo,Door Gear Motor P17	9627-820-002	1
6	Wiring Harness Water Valve/P19	9627-795-004	1
7	Wiring Harness P8/P16	9627-819-001	1
*	Wiring Harness P20/P21	9627-818-002	1
8	Sensor-Pressure Switch	9732-315-001	1
9	Harness Assembly, Pressure Switch	9627-807-002	1
10	Wiring Harness-Main	9627-914-002	1
11	Transformer	8711-010-003	1
12	Optional Relay board	9473-007-001	1

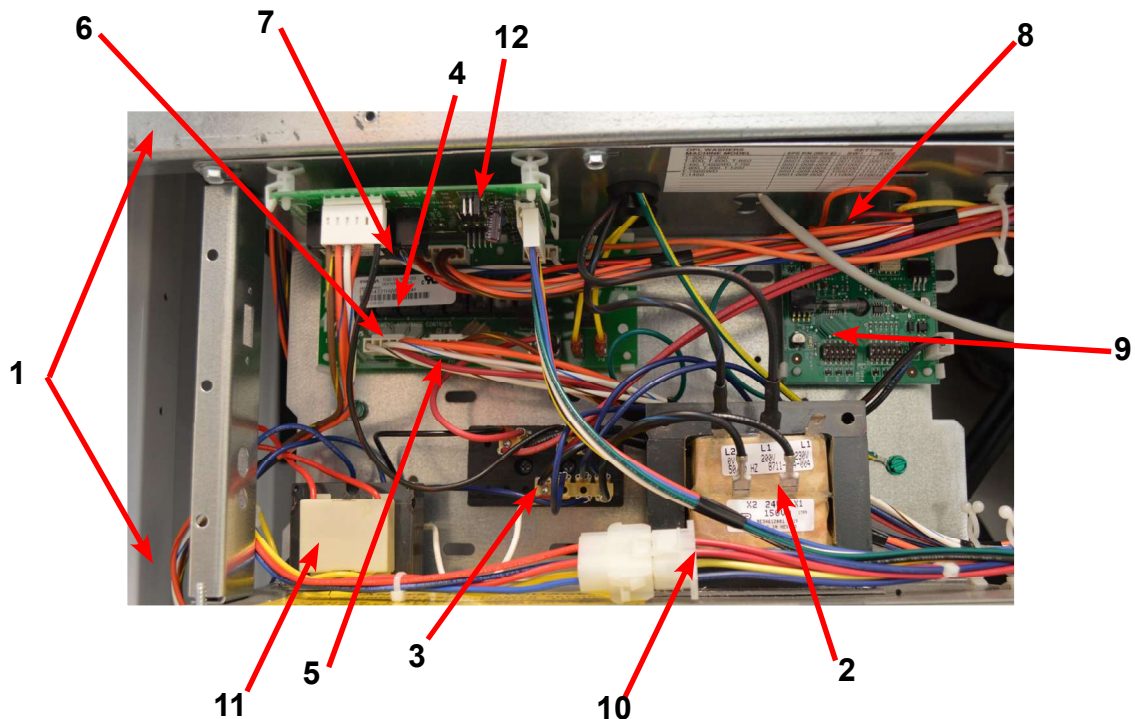

# Electrical Components, Upper Channel

Key	Description	Part Number	Qty
1	Terminal Block Assy, POWER	9897-033-002	1
*	Screw, Mtg 6ABx3/4"	9495-031-010	2
2	Strip, Terminal Marker	9558-025-001	1
3	Terminal, Lug-Solderless (Ground)	8652-134-001	1
*	Screw, 10-32TTx1/2 Green (Control Trough)	9545-008-027	
*	Wiring Harness Power Terminal To VFD & Control Transformer and ground wire	9627-747-003	1
4	VFD Delta drive 208-240 volt	9375-028-025	1
*	Cable, Data Communication	9806-015-002	1
*	VFD MS300, V4	9375-036-019	1
*	Cable, Data Communication, V4 MS300	9806-026-003	1
*	Wiring Assembly Yel. 32"	8220-064-023	2
5	Braking resistors (160 ohm)	9483-004-003	3
*	Wire Assembly-Jumper, BLK (Breaking Resistors)	8220-117-002	2
6	Circuit Breaker 1.5 AMP	5198-211-002	1
7	Terminal Block Assy, Injector	9897-032-002	1
8	Strip-termmarker	9558-028-002	
	Screw-pnhdtorx 4bx5/8 ss	9545-053-002	

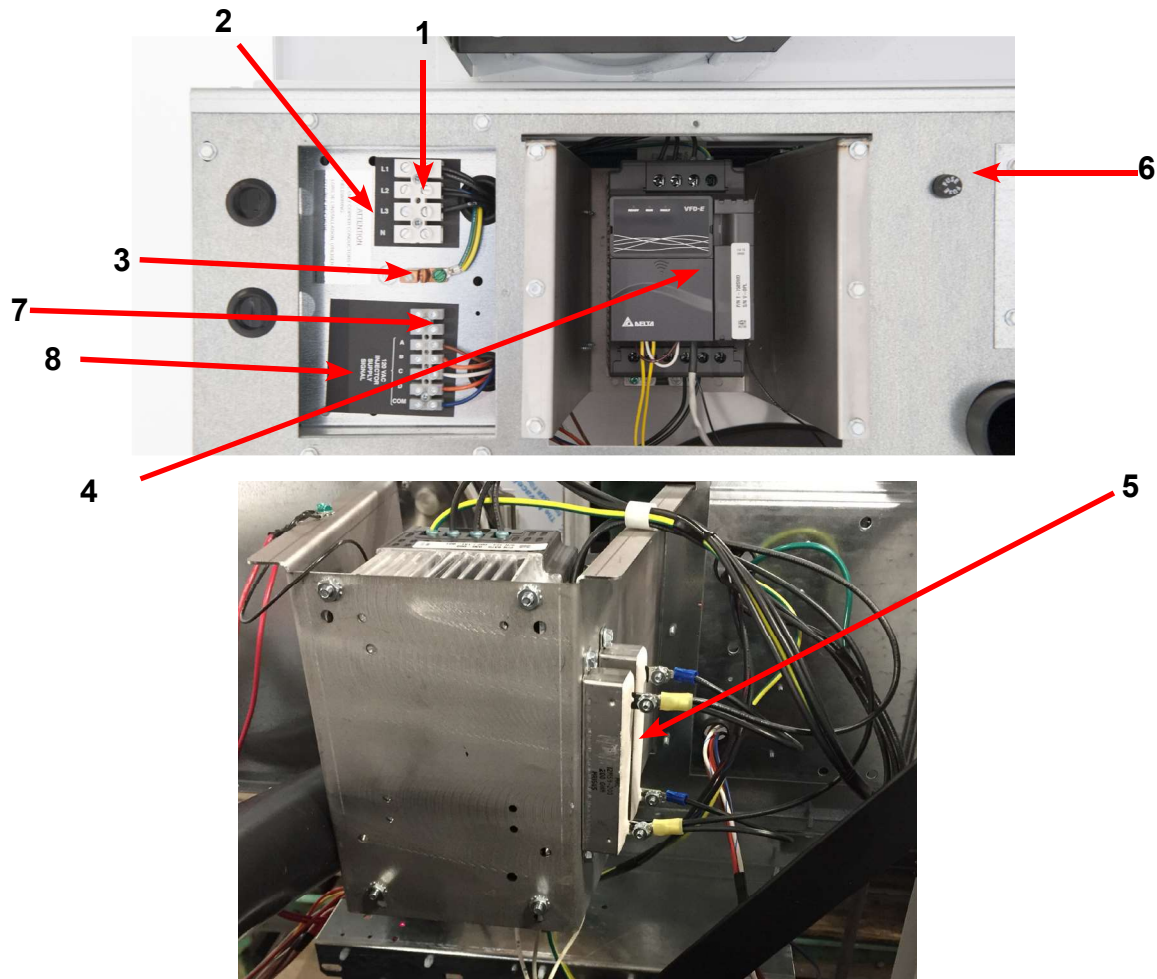

# Front Panel Control Group Part #

Key	Description	Part Number	Qty
*	Nameplate,Control Panel Black(one piece)	9412-234-001	1
1	PCB assembly Control /Display	9473-004-010	1
*	Spacer Push button (Micro)	9538-192-001	1
*	Retainer Push button (Micro)	9486-160-001	1
*	Nut Hexelasticstop #4-40	8640-424-002	2
*	Push button Control (coin)	9035-062-003	1
*	Spacer Plastic #6x9/16	9538-157-018	5
*	Nut Elasticstop #6-32	8640-411-002	4
*	Nut-Hexkeps, #6-32	8640-411-003	1
2	Harness LEDPCB	9627-821-001	1
3	Harness Doorlock, Switches	9627-816-003	1
4	PCB assembly Mode lights	9473-005-001	1
*	Spacer Plastic #6x9/16	9537-157-018	2
*	Nut Hexkeps #6-32	8640-411-003	2
6	Door Locking Actuator 24 volts	9892-017-002	1
*	Hex Nuts (mounting gear motor to control)	8640-412-005	4
7	Battery	8612-001-001	1
8	Add Bleach Light (Wiring Harness included)	9794-001-001	1
9	Lock Run/Program With Harness	8650-027-001	1

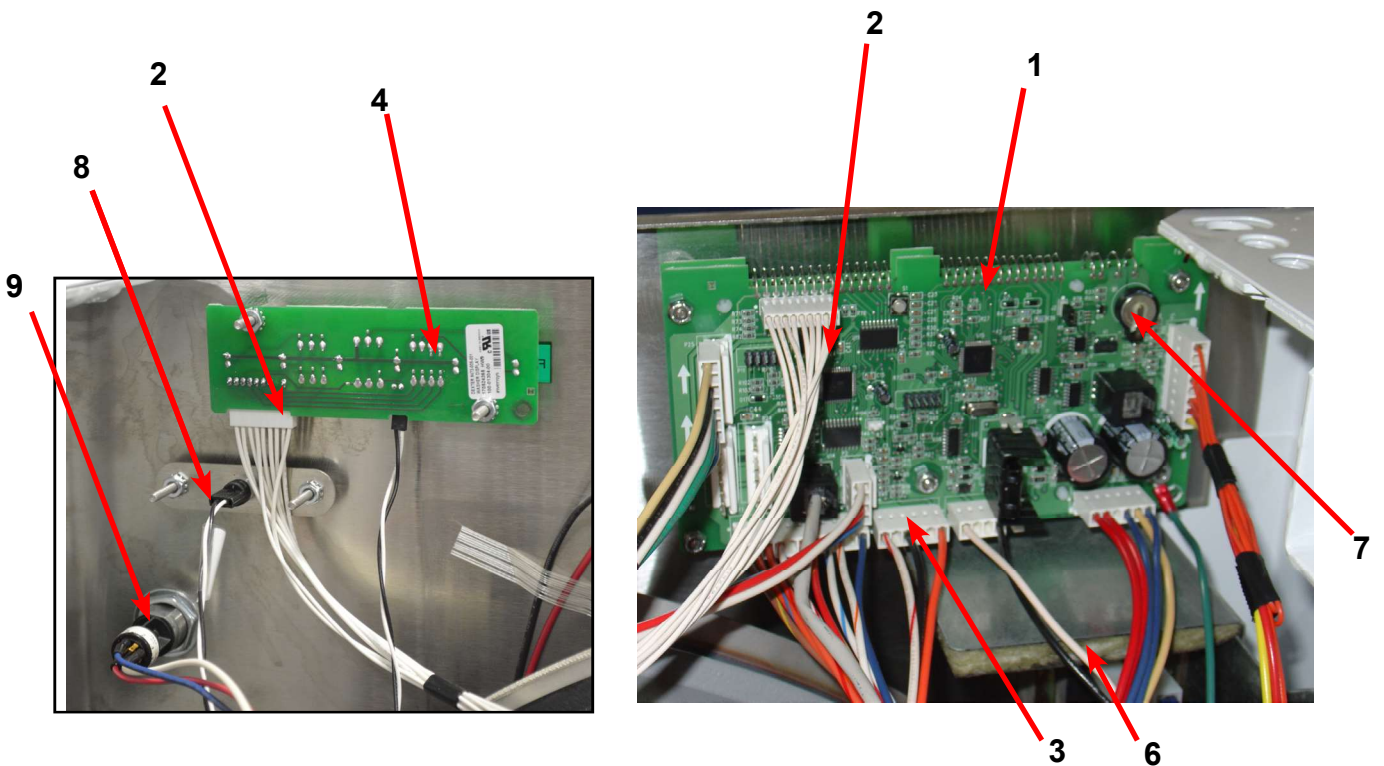

# Labels and Diagrams by Part #

Key	Description	Part Number	Qty
*	Wiring Diagram, OPL	9506-800-001	1
1	Label High Voltage Warning	8502-614-004	1
*	Cover controls	9074-267-001	1
2	Label Fusing & Installation	8502-619-004	1
3	Label Warning Risk of Injury Black	8502-759-001	1
4	Label Warning Door Opening Black	8502-757-001	1
*	Booklet Owners	8514-275-001	1
5	Label, Dispenser Instructions, Black	8502-745-001	1
6	Cover-Motor Control	9074-268-001	1

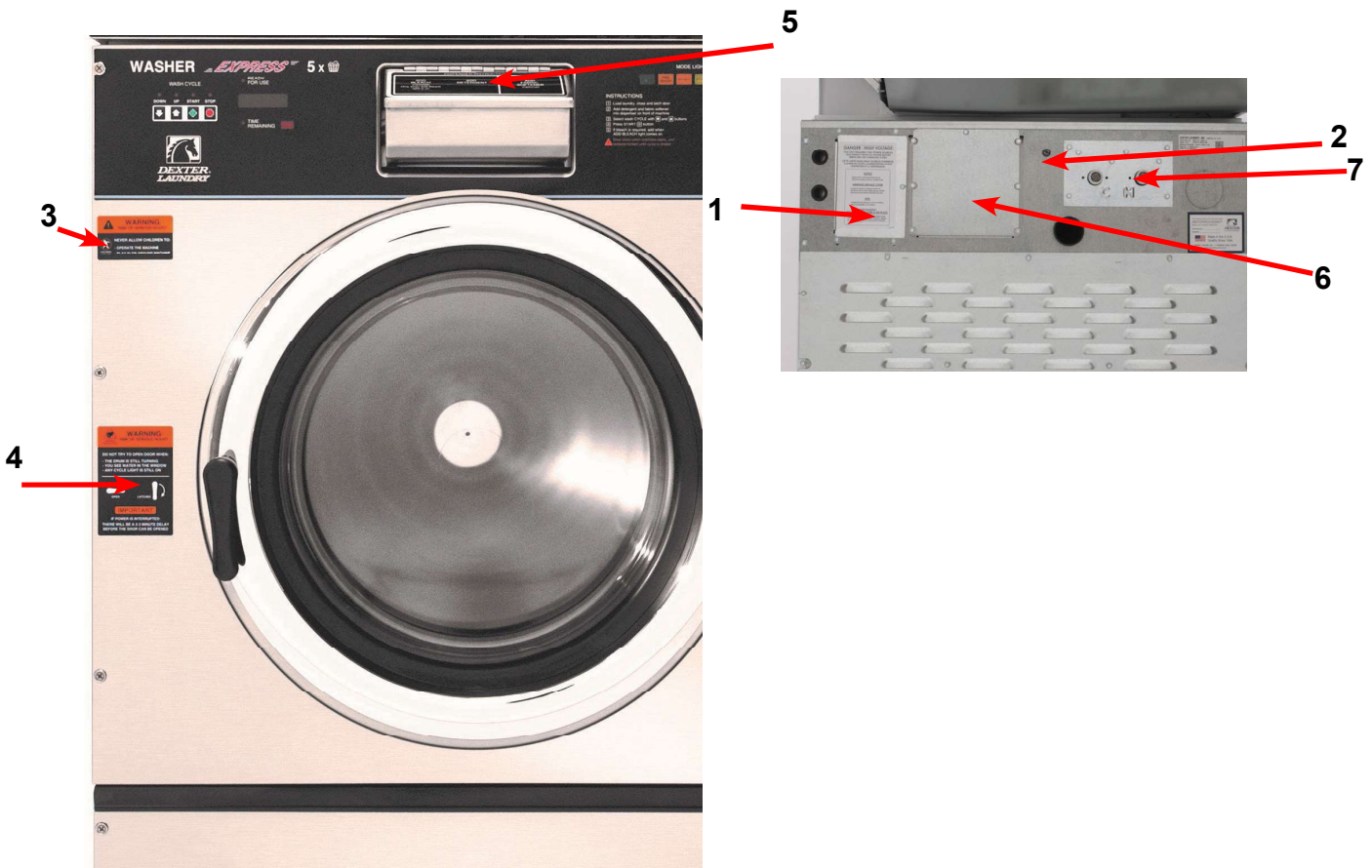

# Wiring Schematic for 60hz opl Washer

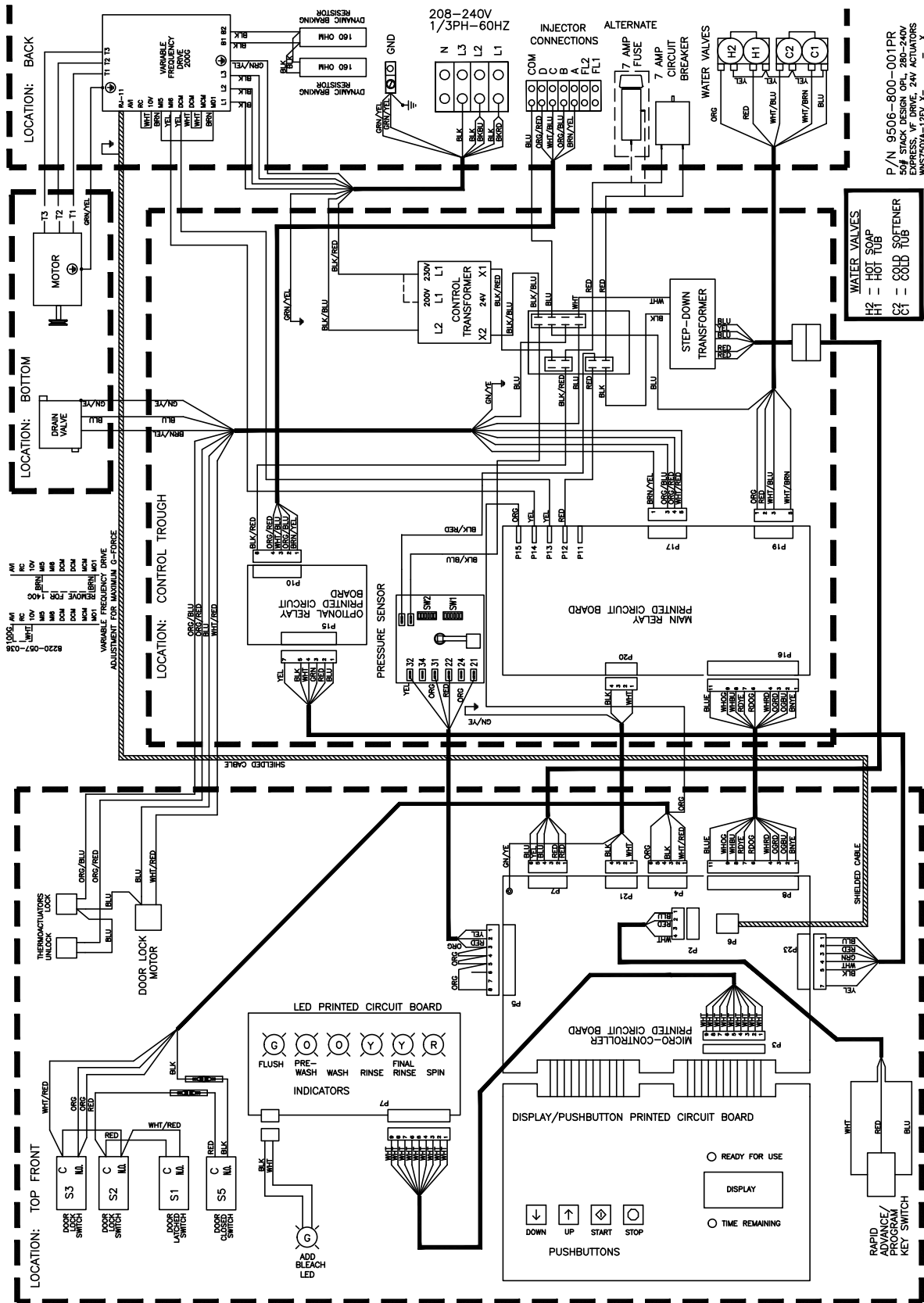

# Wiring Diagram for 60hz opl Washer

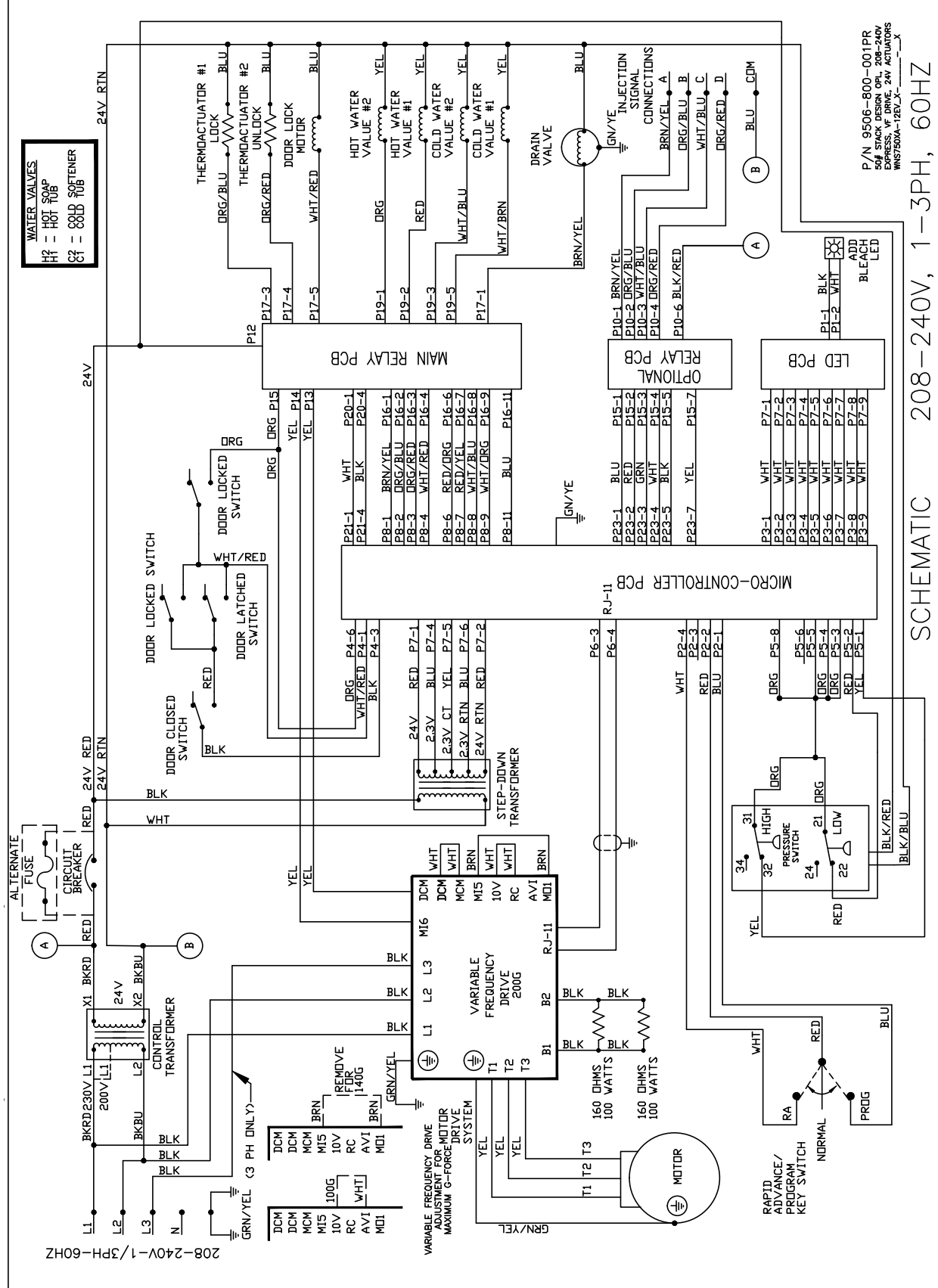



# SWD T-750-12 Diagram V4

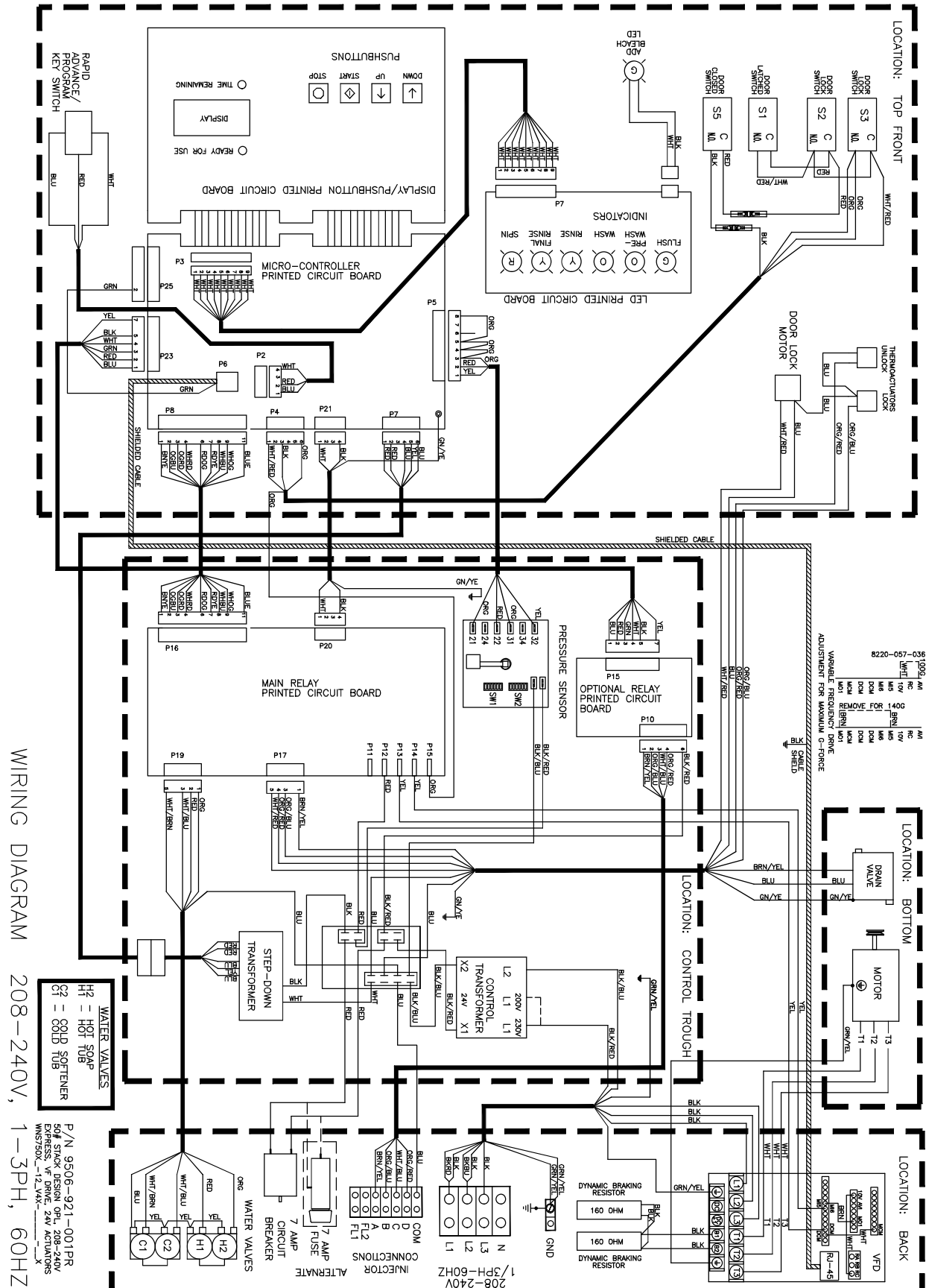

# SWD T-750-12 Schematic V4

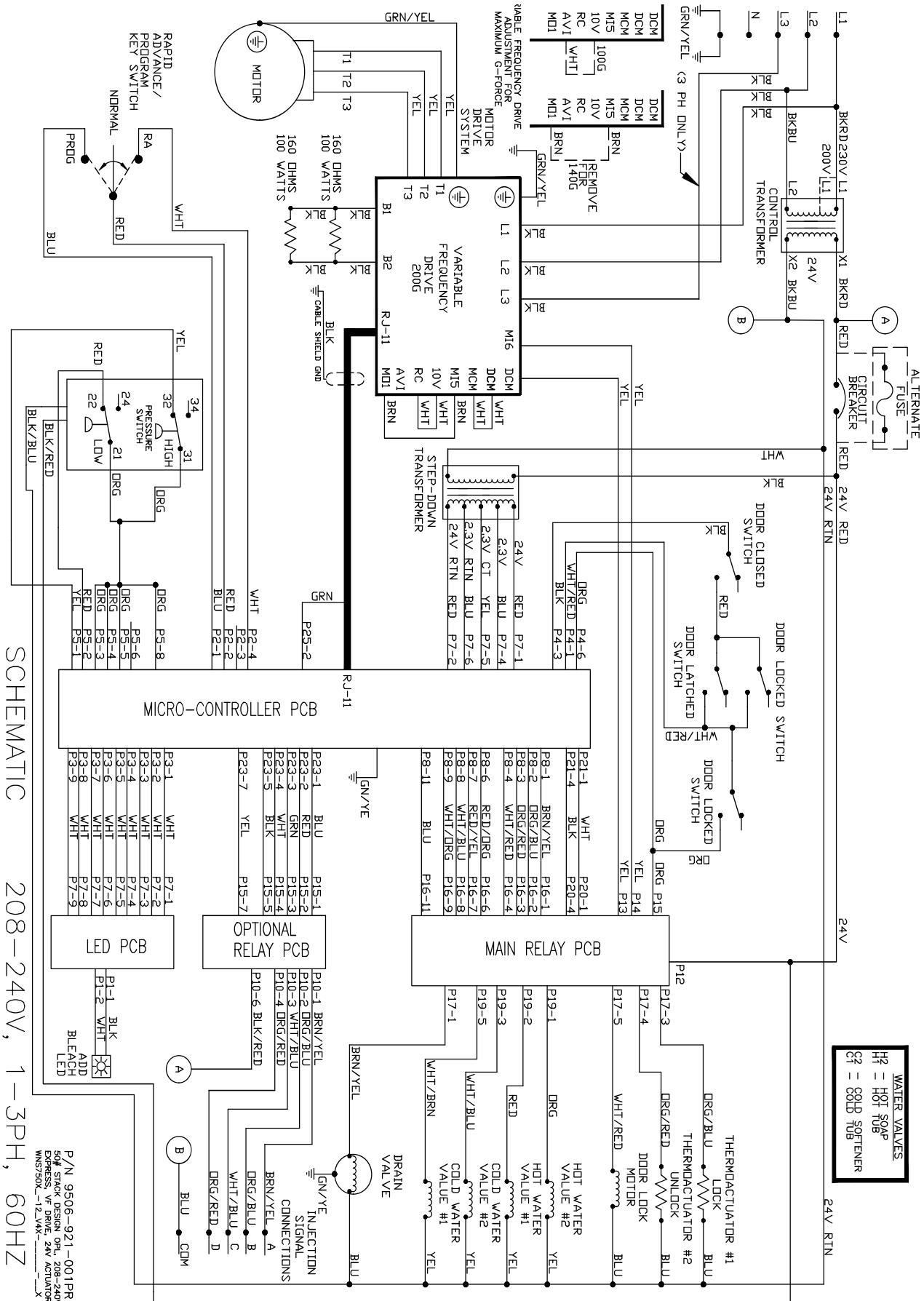

SCHEMATIC 208-240V, 1-3PH, 60HZ

P/N 9506-971-001PR  
 50# STACK DESIGN OPT, 208-240V  
 EXPRESS, VF DRIVE, 24V ACTUATOR  
 WMS750X-12-VX-...-X



---

# Section: 11

## 50 Hz Washer

### Models

Parts in this section used only in these models. All other parts are same as standard 60 Hz pages.

# Wiring Schematic for 50hz Washer -39

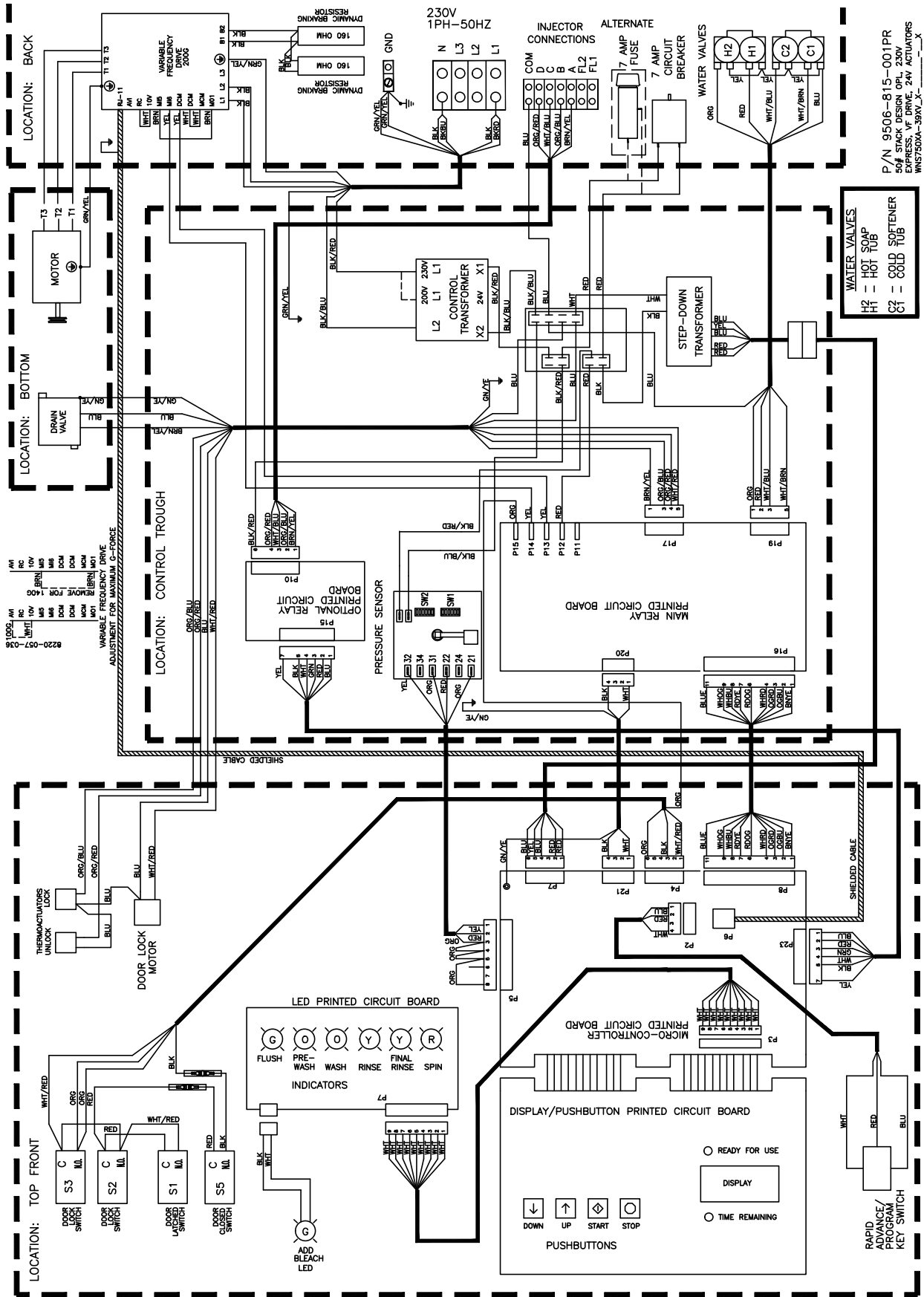

# Wiring Diagram for 50hz Washer -39

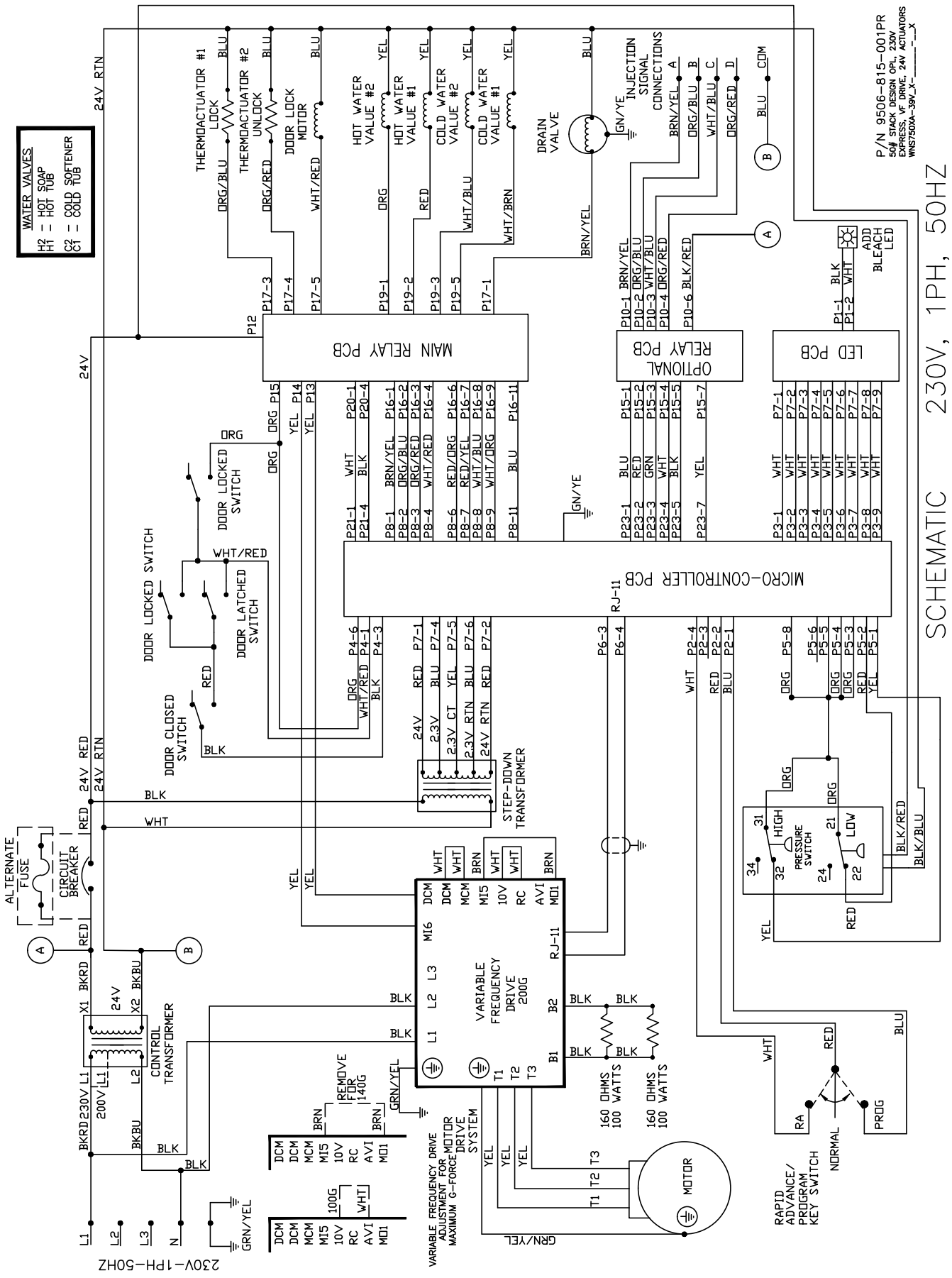

SCHEMATIC 230V, 1PH, 50HZ

P/N 9506-815-001PR  
50# STACK DESIGN OPL, 230V  
EXPRESS, VF DRIVE, 24V ACTUATORS  
WNS7500A-39V\_X\_X\_X

# SWD T-750-39 Diagram V4

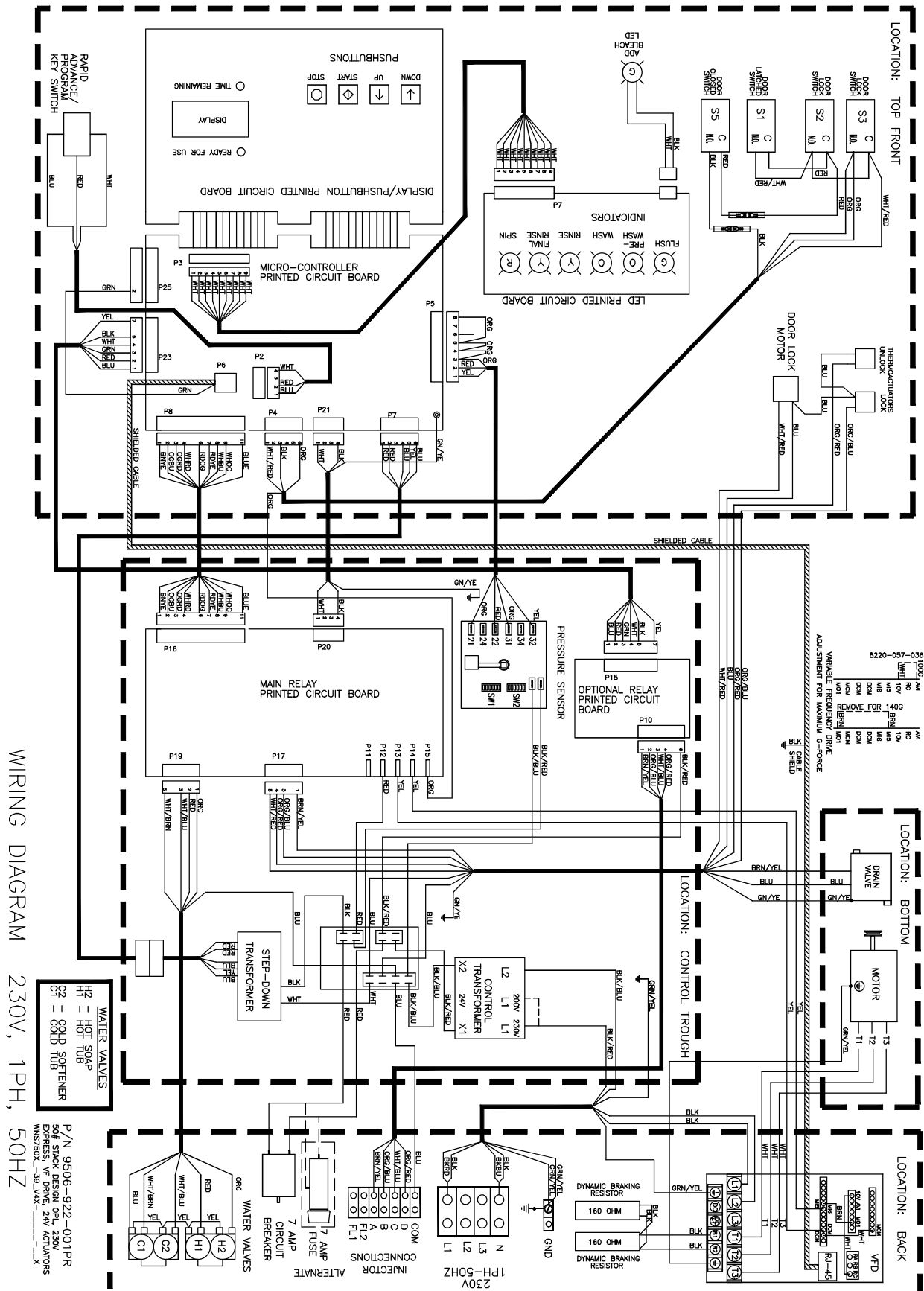

# SWD T-750-39 Schematic V4

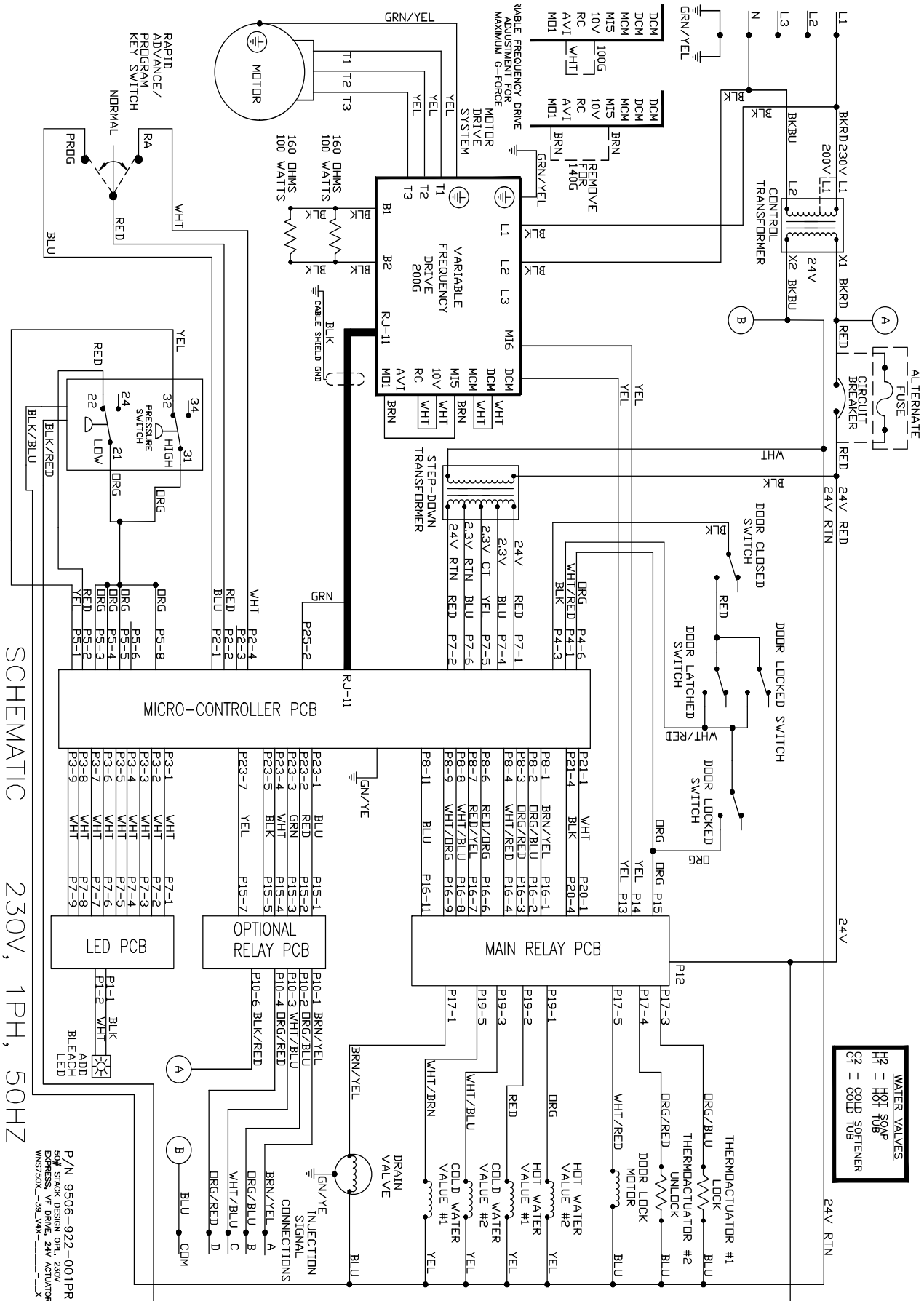

P/N 9506-972-001PR  
 5# STAPACK DESIGN GPL, 230V  
 EXPRESS, VF DRIVE, 24V ACTUATOR  
 WMS750X\_39\_V4X\_...X



---

# Notes

---

---

---

---

---

---

---

---

---

---

---

---

---

---

---

---

---

---

---

---

---

---

---

---

---

---

---

---

---

---

---

---

---

---

---

---

---

---

---