

**NOTES:**

1. DOOR SWITCHES ARE N.O. , SWITCHES CLOSED WHEN DOOR IS CLOSED.
2. MOTOR RUN RELAY CONTACT WILL CLOSE WHEN THE COIN COUNT IS SATISFIED, THE DOOR CLOSED AND THE START BUTTON PRESSED.
3. REFER TO OWNERS MANUAL FOR DESCRIPTION OF OPERATION AND REQUIREMENTS FOR HEATING CIRCUIT.

SCHMATIC DN20X2N\_-39AB\_X-  
 9506-839-001B  
 230V, 1 PHASE, 50 HZ

**IMPORTANT: RETAIN THIS ELECTRICAL SCHEMATIC FOR SERVICE.**

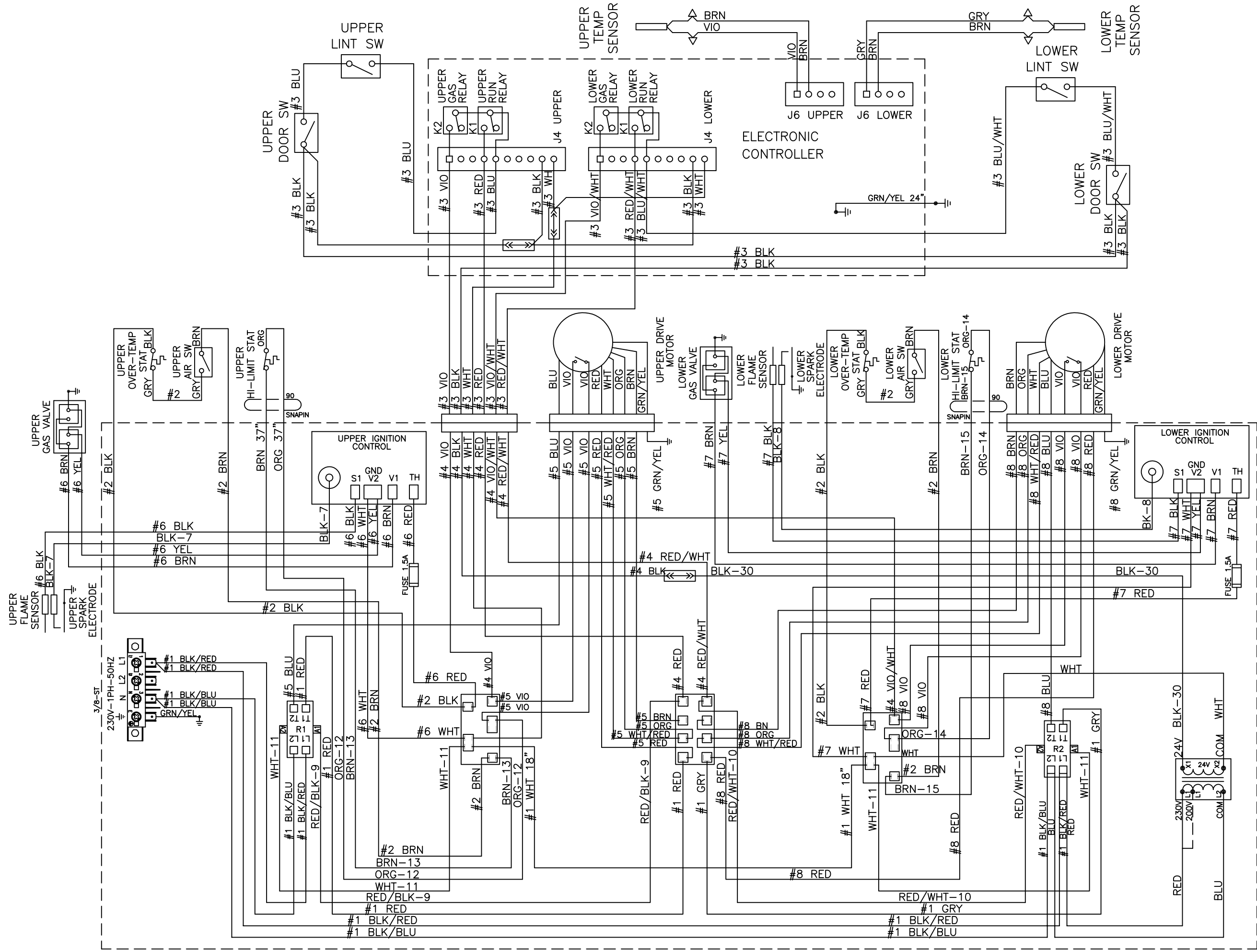

9506-839-001B WIRING DIAGRAM DN20X2N\_-39AB\_X-

**IMPORTANT: RETAIN THIS ELECTRICAL DIAGRAM FOR SERVICE.**