

REVISION HISTORY		APP
REV	DESCRIPTION	
PR	RELEASE FOR PRODUCTION 9945-145-001	SC
ECN 00292	05/20/15	

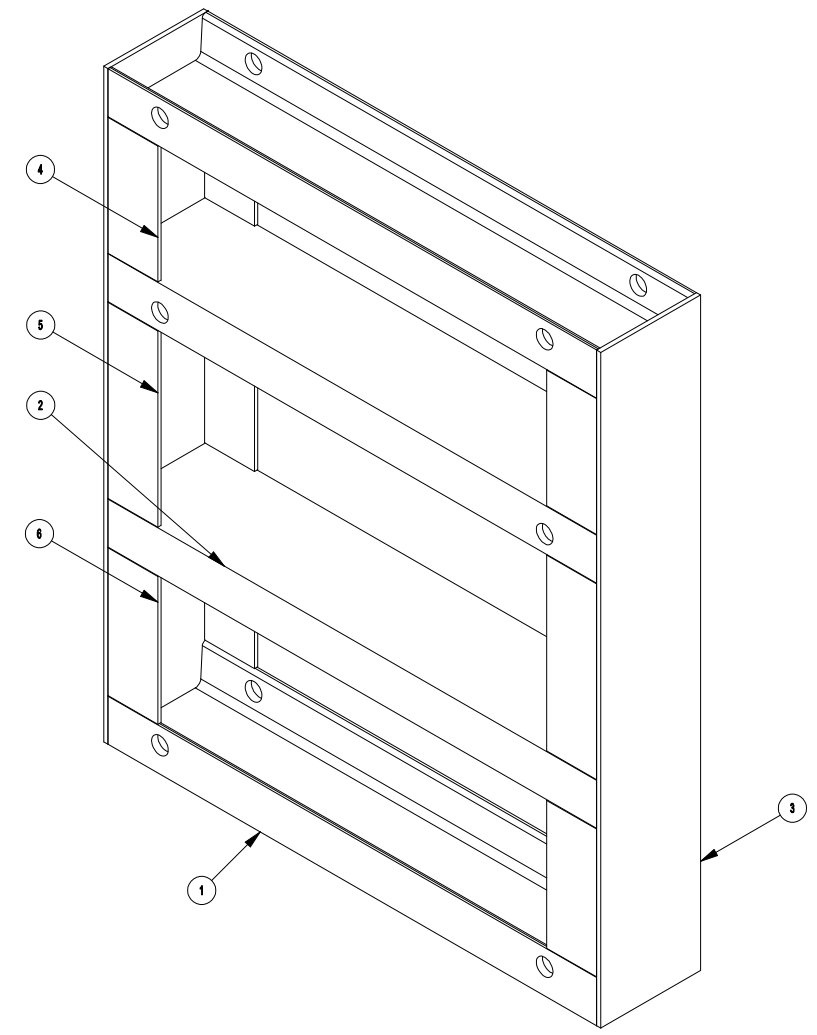
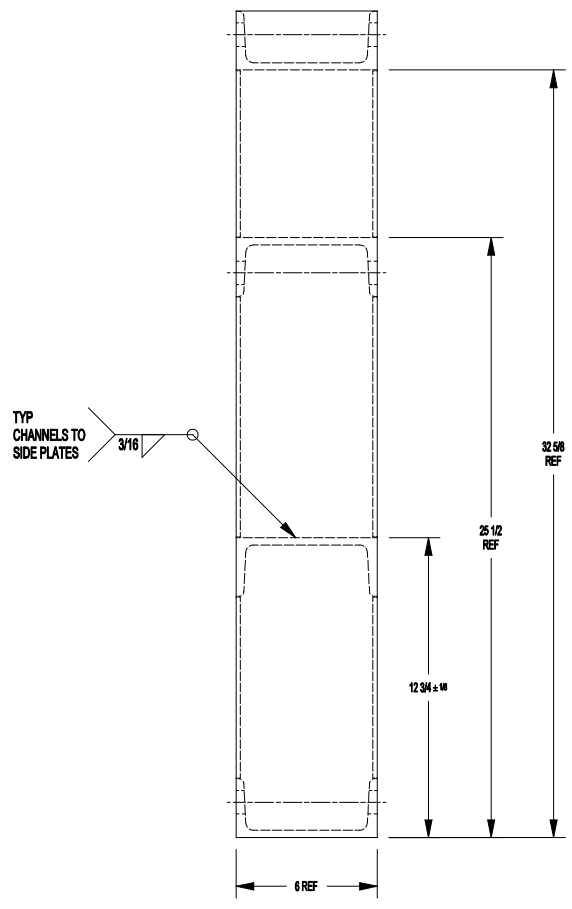
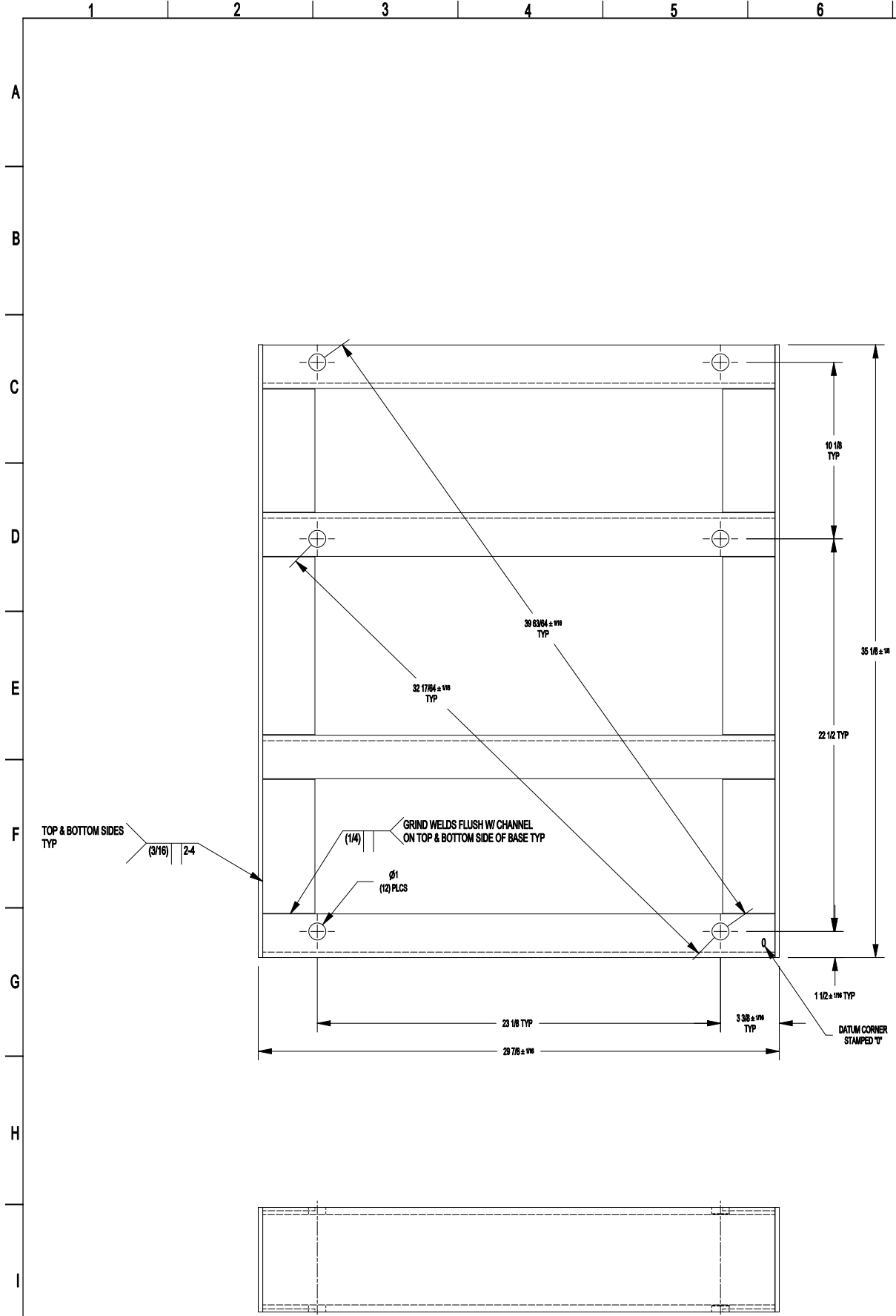

NOTES:  
 1. PART TO BE FLAT WITHIN 1/8"  
 2. FILLER PLATES TO BE FLUSH TO 1/16" RECESSED FROM SURFACE OF CHANNELS.  
 3. APPLY (1) COAT FLAT BLACK PAINT.

QTY	PART NUMBER	ITEM	DESCRIPTION
4	PLATE4	6	3/16 X 3 X 7 11/16 HR STEEL
4	PLATE3	5	3/16 X 3 X 10 3/16 HR STEEL
4	PLATE2	4	3/16 X 3 X 7 1/16 HR STEEL
2	PLATE1	3	1/4 X 6 X 35 1/8 HR STEEL
1	CHANNEL2	2	MCG X 12#FT STEEL CHANNEL X 29 3/8 LG
3	CHANNEL1	1	MCG X 12#FT STEEL CHANNEL X 29 3/8 LG

9945-145-001 BASE ASSY - 1 PLACE, 8" (T-650)

REWARD-HIP BRICK COMPANY  
TOLERANCES UNLESS OTHERWISE SPECIFIED

**DEXTER LAUNDRY INC.**  
FAIRFIELD, IOWA

FRACIONS	± .04	DECIMAL	± .05	ANGULAR	± .2	REFERENCE	(0.0)
TOLERANCES UNLESS OTHERWISE SPECIFIED		DECIMAL	± .05	ANGULAR	± .2	REFERENCE	(0.0)

DATE: 05/20/15  
 DWG NO: 9945-145  
 SCALE: 1/4" = 1"  
 SIZE: D  
 SHEET: 1 OF 1  
 REV: PR