



DEXTER[®]
LAUNDRY

**USE THE BLUE TABS LOCATED ON THE
RIGHT AND LEFT SIDES OF THE FOLLOWING
DOCUMENT TO ADVANCE TO EACH SECTION.**

Wiring Harness Part # by Model

Part Number	Description	Qty
9627-696-002	Wiring Harness, Main	1
9627-689-001	Wiring Harness, Control	1
9627-708-001	Wiring Harness, Coin accumulator (countdown)	1
8654-125-001	Clamp, Cable- 1/4 Dia	1

Section 6:

Parts Data

N-Series Vended

Regular Chassis

Models
WCN18AA
WCN18AB

Cabinet and Front Panel Group Part # by Model WCN18AA/WCN18AB

Key	Part Number	Description	Qty
1	9454-635-006	Panel, Side (Left) - Stainless	1
2	9454-635-005	Panel, Side (Right} - Stainless	1
3	9545-018-018	Screw, (Side Panel to Base)	6
*	8640-414-006	Nut, Hex	6
*	9029-066-001	Bracket, Side Panel	1
*	8640-413-002	Nut, Hex	2
*	9545-008- 026	Screw	2
4	9454-668-001	Panel Assy, Front	1
*	9059-063-004	Band, Edge Protector	1
*	8640-399-008	Nut, Spring (Attaches Top of Panel}	3
*	9545-008-026	Screw, Hex (Attaches Top of Panel}	5
5	9545-008-014	Screw, Flat Head	2
5	8641-585-001	Washer, Finish	2
*	8640-399-008	Nut, Spring-To Front Panel	2
*	9545-008-023	Screw, Guide	2
6	8502-624-002	Label, Door Opening	1
7	9989-451-001	Panel, Control (Mounts Nameplate)	1
*	9545-008-026	Screw, Control Panel Mtg	4
8	9412-074-003	Nameplate, Control Panel T-300	1
9	9454-662-001	Panel, Top	1
10	8650-012-003	Lock, Top (w/Key)	1
*	9306-025-001	Key, Top-6324	1
*	9095-038-001	Cam, Lock-Top	1
*	8640-426-001	Nut, 9/32	1
*	8641-581-008	Washer	1
11	9108-096-001	Door, Lower Service	1
12	9244-081-001	Handle (bumper guard)	1
*	9545-045-01 0	Screw	4
13	9545-008-014	Screw Mtg., Flat Head	2
13	8641-585-001	Washer, Finish	2
*	9545-008-023	Screw, Guide	2
14	9108-095-003	Door, Dispenser	1
*	9451-191-001	Pin, Plain ss	2
15	9467-025-001	Post, Door Mounting	2
*	9545-045-002	Screw, Dispenser Post Mtg	4
*	9545-008-012	Screw, Dispenser Mounting	4
*	8640-399-007	Nuts, Spring	4
*	9086-017-001	Catch, Top Panel	2
*	9467-024-001	Post, Top Locator	2
*	8640-411-003	Nut, Keps	2
*	9355-001-001	Locator, Panel	2
*	9545-008-025	Screw,#10	2
16	9021-001-010	Acceptor, Coin (25c)	1
17	9732-122-001	BoxAss'y Coin(see coin box group)	1

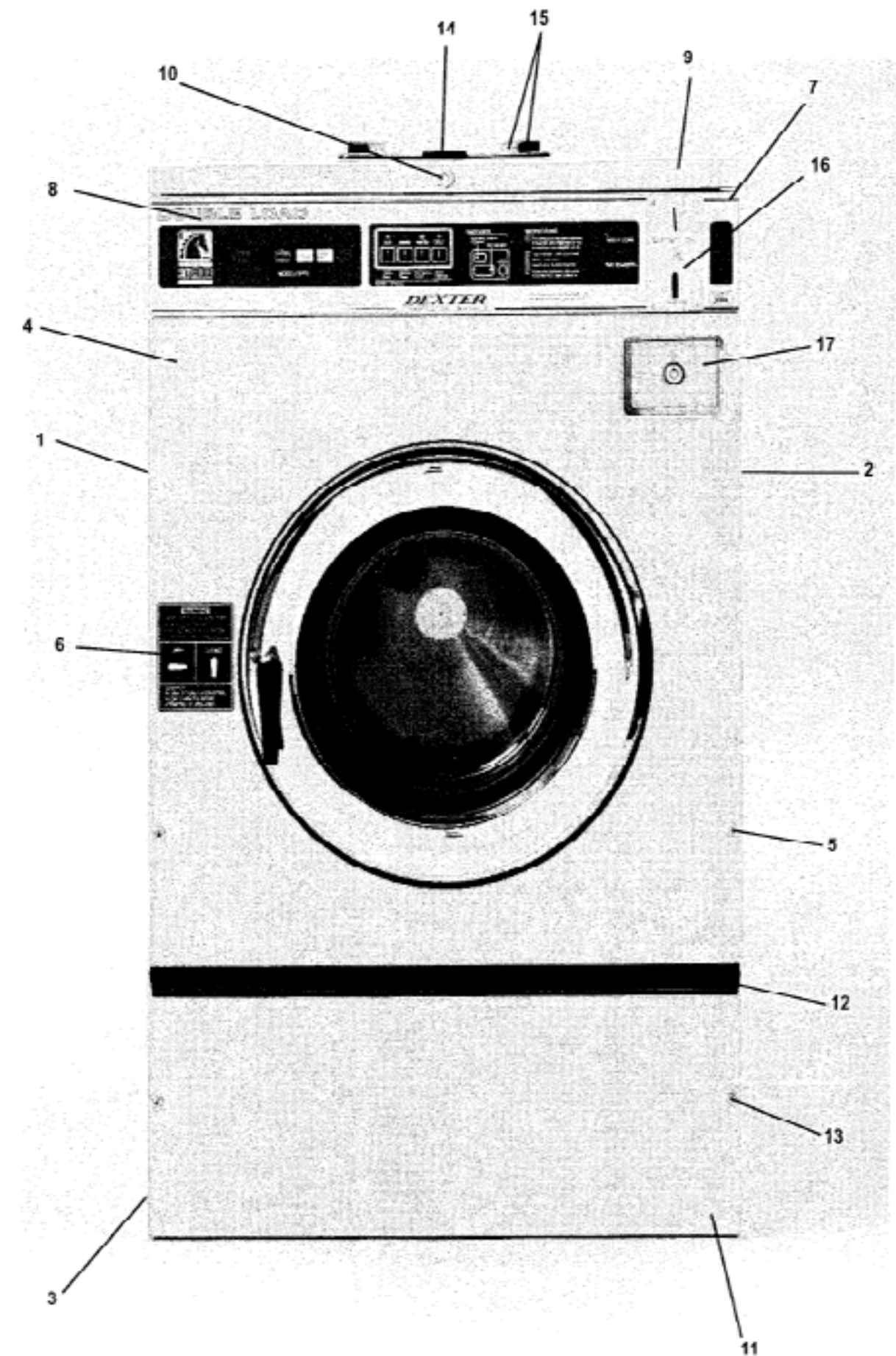

Rear View Access Part # by Model WCN18AA/WCN18AB

Key	Part Number	Description	Qty
1	9732-127-009	Drive Motor, 1 Phase	1
1	9732-127-010	Drive Motor, 3 Phase	1
2	9497-222-002	Rod, Motor Mtg	1
3	9545-029-005	Screw (end of motor rod)	1
3	8641-582-014	Lockwasher (end of motor rod)	1
3	9076-052-002	Collar, Shaft (w/set screws)	3
*	9053-074-001	Bushing, Motor Hangar	2
4	9453-169-006	Pulley, Motor	1
*	9545-028-015	Set Screw, Sq. Hd	2
5	9908-041-002	Pulley, Driven	1
6	9545-017-009	Screw	1
6	8641-581-026	Washer, Flat	1
6	8641-582-016	Lockwasher	1
7	9040-076-004	Drive Belt	1
8	9081-099-001	Channel, Rear	1
*	9545-008-026	Screw	4
*	8640-399-004	Nut, Spring	4
9	9242-463-001	Hose, Overflow 9"	1
10	9242-449-002	Hose, Overflow	1
*	8654-029-000	Clamp, Hose	2
11	9122-005-004	Dispenser--(washcompound)	1
12	9206-416-001	Gasket, Dispenser	1
*	9454-632-001	Panel Assy., Back	1
*	9545-008-026	Screw	10
*	8640-399-004	Nut, Spring	10
*	9242-175-000	Hose, Pressure Switch	1
*	8654-117-015	Clamp, Pressure Sw. Hose	1
13	5198-211-004	Circuit Breaker, 1.5 amp (3-phase)	1
*	5198-211-002	Circuit Breaker, 7 amp (1-phase)	1
14	9029-027-003	Strap, Motor Tension	1
15	8640-413-002	Nut, Strap to Motor	1
15	8641-581-008	Washer	1
16	9534-319-002	Spring, Belt Tension	1
17	9545-055-001	Bolt, Eye 1/4-20x2 1/2"	1
18	8640-414-003	Nut, 1/4 Elastic Stop	1
19	9545-029-003	Screw, 3/8"x 1 1/2"	12
*	8640-415-004	Nut, Flange Lock	12
*	9552-038-003	Shim	AR
*	9456-041-007	PLASTIC PLUG(inside cylinder)	1
*	9454-632-001	Back Panel	1

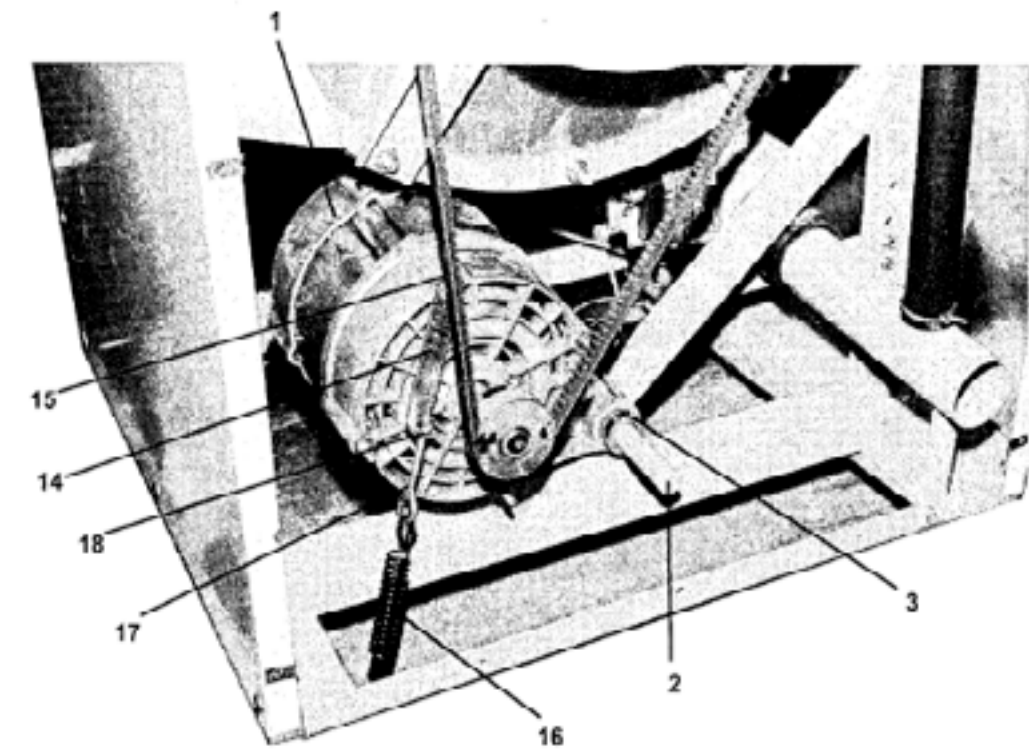
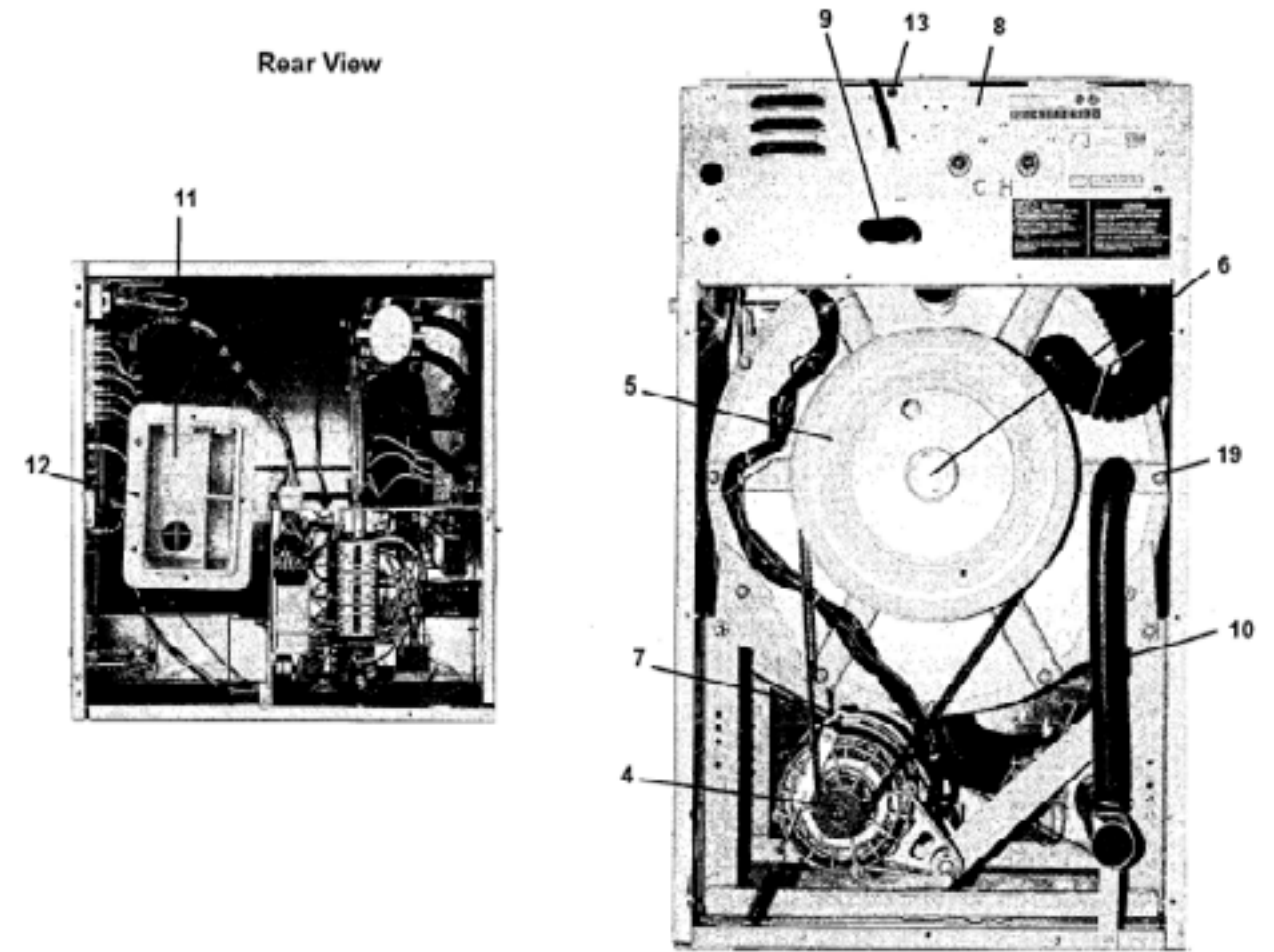

Cylinder, Seals & Bearings Part # by Model

Key	Part Number	Description	Qty
*	9848-111-001	Cylinder, Assy	1
*	9803-182-001	Housing, Bearing-Assembly (includes items #2-#6)	1
2	9241-174-002	Housing, Bearing	1
3	9036-159-001	Bearing, Front	1
4	9036-159-003	Bearing, Rear	1
5	9538-161-001	Spacer, Bearing	1
6	9487-238-002	Ring, Bearing Retainer	1
7	9532-140-005	Seal, Secondary	1
8	9532-140-004	Seal, Primary	1
9	9950-047-001	Ring, Seal Mtg	1
9a	9732-137-001	Ring, Seal Ass'y Tub Back before serial number #425580	1
*	9487-261-001	New Style Ring Ass'y Tub Back after serial number# 425580	1
10		Back Assy, Tub	1
11	9545-017-009	Screw, 1/2 x 1 1/4 Grade 5	6
11	8640-417-002	Nut	6
11	8641-582-016	Lockwasher	6
12	9991-049-002	Support Assy., Bearing Housing	6
13	9545-029-003	Screw, 3/8 x 1 1/2 Grade 8	6
13	8640-415-004	Nut	6
14	9908-041-002	Pulley, Driven	1
15	9487-234-002	Ring, Tolerance	1
16	8641-581-026	Washer	1
16	9545-017-009	Screw	1
16	8641-582-016	Lockwasher	1
17	9950-046-002	Ring ass'y Tub Mtg. rear	1
18	9962-009-003	Tub Back Only before serial number# 425580	1
*	9962-012-001	Tub Back Only after serial number #425580	1

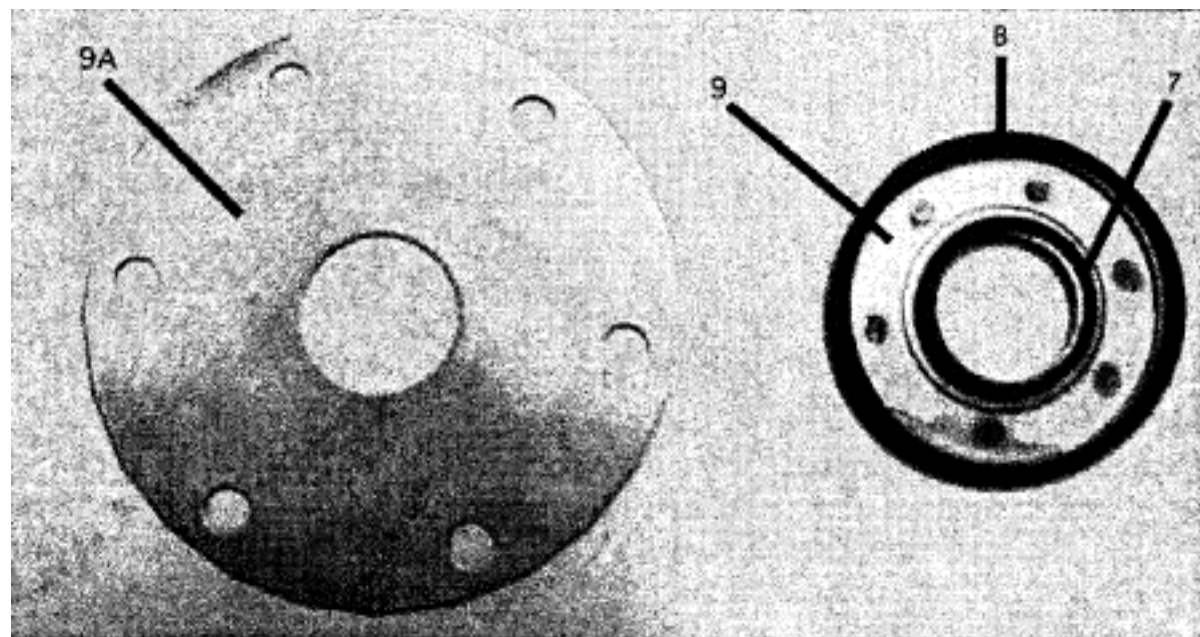

Bearing Housing and Pulley Group

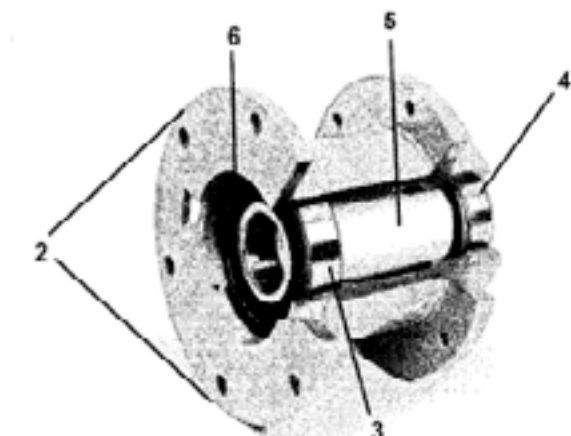
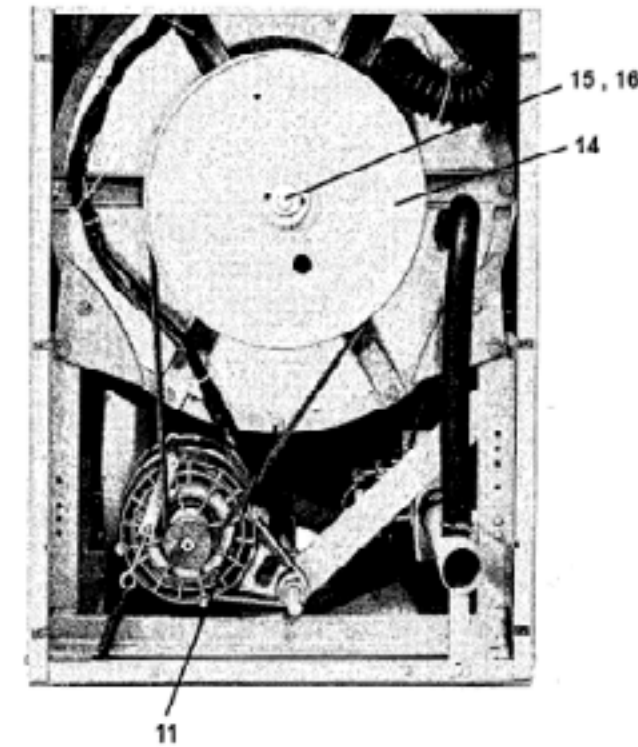
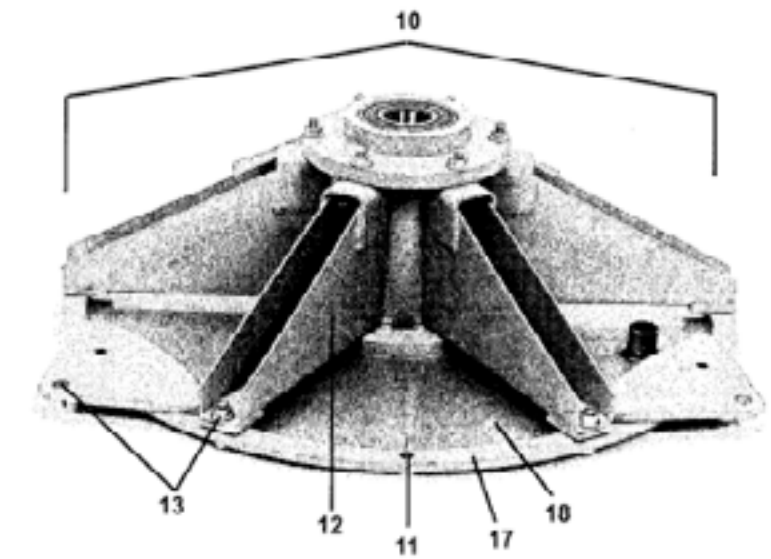

Door Latching & Solenoid Door Lock Assemblies by Part

Key	Part Number	Description	Qty
*	9885-023-001	LockAssy, Complete (includes #1 thru #22)	1
1	9982-284-001	Plate Assy, Door Lock	1
2	8641-581-030	Washer, Flat	1
3	9008-005-001	Actuator, Latching Switch	1
4	9450-002-002	Pawl, Locking	1
5	8641-569-003	Washer, Spring	1
6	9487-200-004	Ring, Ret Jning	1
7	9029-035-001	Bracket; SOWiitch	1
8	8640-413-002	Nut, Hex 10-32 UNF	2
9	9534-364-001	Spring, Actuating	2
10	9545-012-020	Screw, Hx. 10-32 x 1	1
11	8640-413-004	Nut, E.lastic Stop 10-32	2
12	9534-364-002	Spring, Return	1
13	9451-193-001	Pin, Guide	1
14	9487-200-005	Ring, Retaining	1
15	8641-581-031	Washer	2
16	9539-461-008	Switch, Latching Sensing	1
17	9550-169-003	Shield, Switch	3
18	9545-020-001	Screw 4-40 x 5/8	2
18	8640-401-001	Nut, Twin	1
19	9539-461-007	Switch, Locking Sensing	2
20	9008-006-002	Actuator, Switch	2
21	9545-020-003	Screw 4-40 x 1 1/8	2
21	8640-401-001	Nut, Twin 4-40	1
22	9451-181-004	Pin, Dowel	1
*	9552-037-001	Shim, Door Lock, Thin	AR
*	9552-037-002	Shim, Door Lock, Thick	AR
*	9545-018-014	Screw, Lock mtg 1/4 -20 x 3/4	3
*	8641-582-007	Lockwasher 1/4 Ext tooth	3
*	9922-011-001	Solenoid Ass'y, Door Locking (includes 23 thru 32)	1
23	9029-073-001	Bracket, {Door Locking Solenoid)	1
24	9985-169-001	BracketAss'y, Soienoid Slide	1
25	9536-074-001	Solenoid 120V 60 hz	1
26	9545-008-001	Screw, Solenoid Mtg	4
27	9540-033-002	Stop, Door Lock Solenoid	1
28	9545-061-001	Screw, Shoulder	1
28	8640-411-003	Nut, Keps #6	1
29	9586-001-001	Thermoactuator 120 V	2
30	9545-031-011	Screw. #6 x5/16	4
31	9538-157-004	Spacer, Plastic	1
31	9538-166-004	Spacer, Metal	1
31	9545-010-001	Screw, Cross Recessed	1
31	8640-412-005	Nut, Keps #8	1
32	8640-411-002	Nut, Keps#6	1
*	8640-412-005	Nut, Sol.Brkt. to Control. Panel	3
*	9497-225-006	Rod, Pull	1

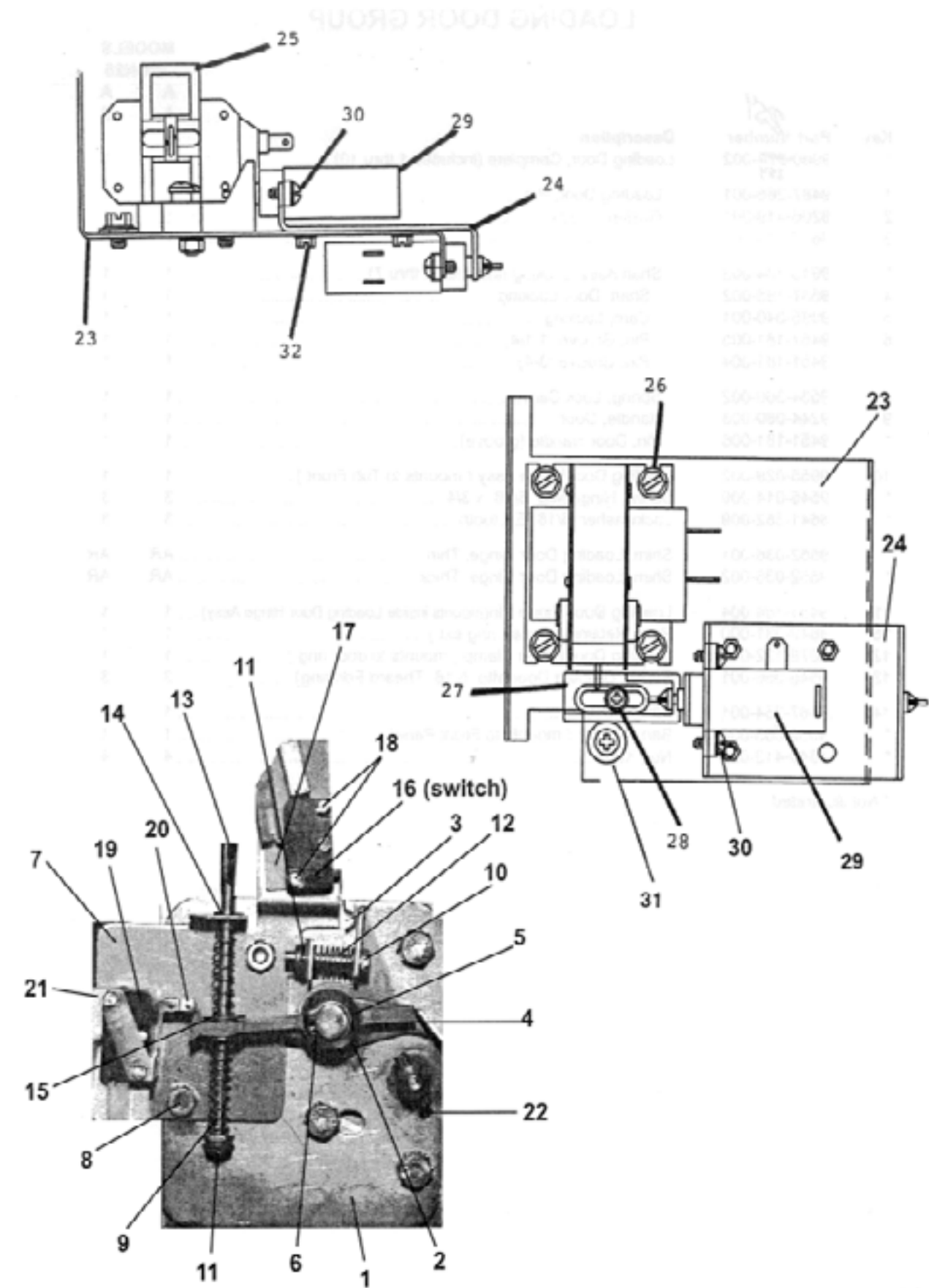

Loading Door Part # by Model

Key	Part Number	Description	Qty
*	9960-259-003	Loading Door, Complete (includes #1 thru #10)	1
1	9487-245-001	Loading Door, Ring	1
2	9206-411-002	Gasket, Loading Door	1
3	9635-018-001	Window, Loading Door Glass	1
4	9913-134-003	Shaft Assy, Locking (includes #5 thru #8)	1
5	9537-195-002	Shaft, Door Locking	1
6	9095-040-001	Cam, Locking	1
7	9451-181-005	Pin, Groove (1 1/4)	1
8	9451-181-004	Pin, Groove (3/4)	1
9	9534-360-002	Spring, Lock Cam	1
10	9244-080-003	Handle, Door	1
*	9451-181-006	Pin, Door Handle (groove)	1
11	9955-029-001	Hinge Assy, Loading Door	1
*	9545-014-009	Screw, Hinge Mtg	3
*	8641-582-009	Lockwasher	3
*	9552-036-001	Shim, Loading Door Hinge, Thin	AR
*	9552-036-002	Shim, Loading Door Hinge, Thick	AR
13	9451-184-003	Pin, Loading Door Hinge	1
*	8649-031-000	Ring, Retaining	1
14	9079-122-001	Clamp, Loading Door Hinge Pin	1
16	9545-056-001	Screw, Loading Door Mtg	3
15	9487-251-001	Ring, Masking	1
*	8640-413-002	Nut	4
	9732-139-002	Kit Door Gasket Expansion (large)	
	9732-139-001	Kit Door Gasket Expansion (small)	

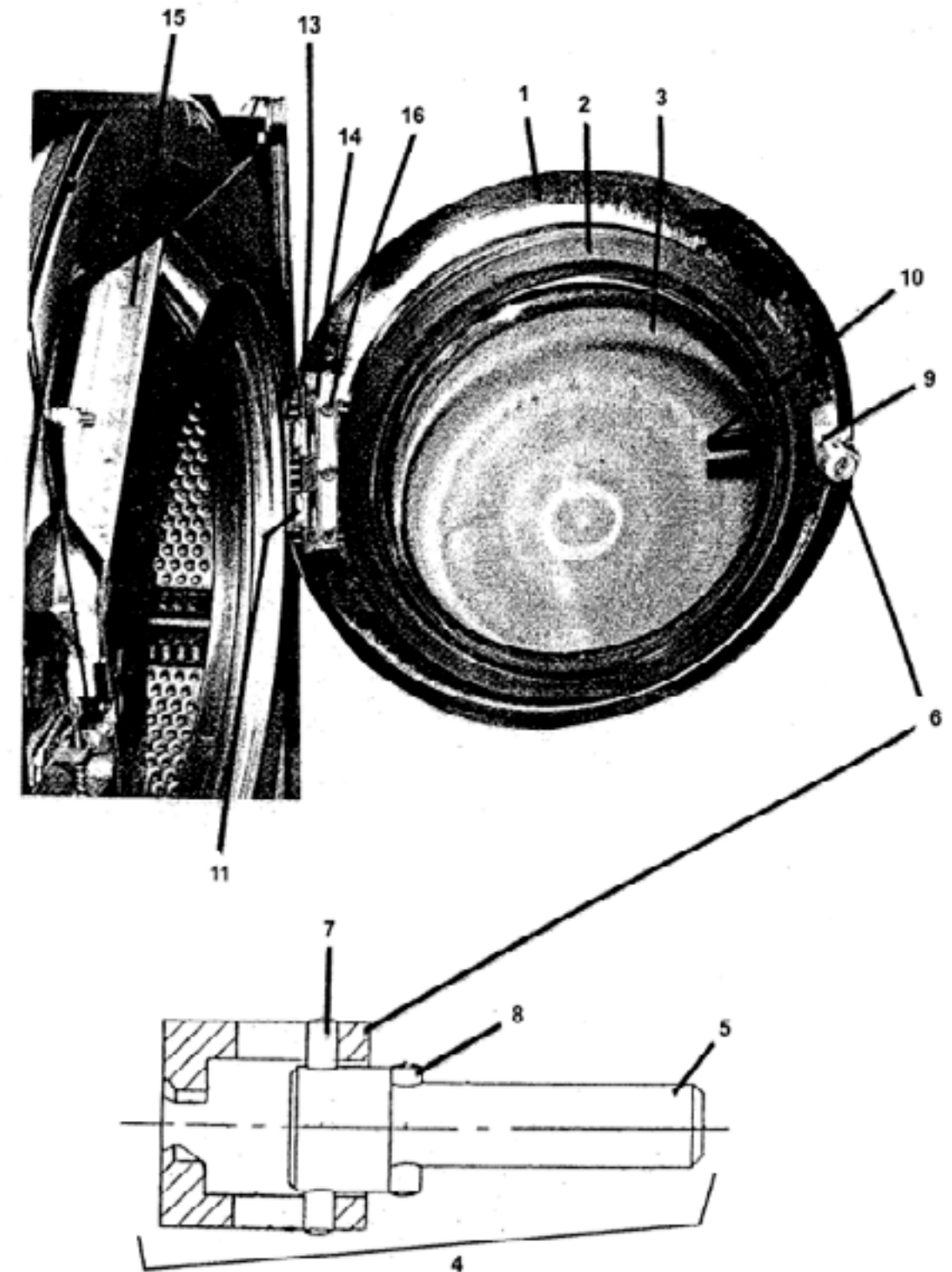

Chassis and Drain Part # by Model

Key	Part Number	Description	Qty
1	9945-093-002	Base Assy, Frame	1
2	9930-135-001	TubAssy	1
3	9950-045-002	Ring Assy, Tub Mtg-Front	1
4	9545-017-012	Bolt, Top Front Ring 1/2" x 3"	1
4	8641-582-016	Lockwasher	1
4	8640-417-002	Nut	1
6	9545-017-009	Screw, Front & Rear Rings to Base 1/2" x 1 1/4"	4
6	8641-582-016	Lockwasher	4
6	8640-417-002	Nut	4
7	9379-177-006	Valve, Drain (2 1/4" ball type)	1
8	9029-005-001	Bracket, Drain Valve	1
*	9545-030-002	Screw, Valve to Bracket	1
*	8641-581-018	Washer	1
9	9545-030-002	Screw, Bracket to Base	2
10	9915-116-004	Tube Assy, Drain	1
*	9545-030-002	Screw, Tube Mtg	2
11	9242-455-001	Hose, Tub to Drain Valve	1
12	9242-451-002	Hose, Drain Valve to Outlet	1
*	8654-117-014	Clamp, Hose	3
13	9732-127-009	Motor, Drive (1 PH)	1
13	9732-127-010	Motor, Drive (3 PH)	1
14	9497-222-002	Rod, Motor Mtg	1
15	9076-052-002	Collar, Shaft	2
16	9545-029-005	Screw, Motor Mtg Rod	1
16	8641-582-014	Lockwasher	1
17	9453-169-006	Pulley, Motor	1
*	9545-028-015	Set Screw, Sq. Hd	2
18	9040-076-004	Belt, Drive	1
*	9552-038-003	Shim, Support Assembly	AR
19	9242-458-001	Vacuum Breaker to Tub	1
24	9242-450-002	Hose, Dispenser to Tub	1
*	8654-117-008	Clamp, Dispenser Hose	2

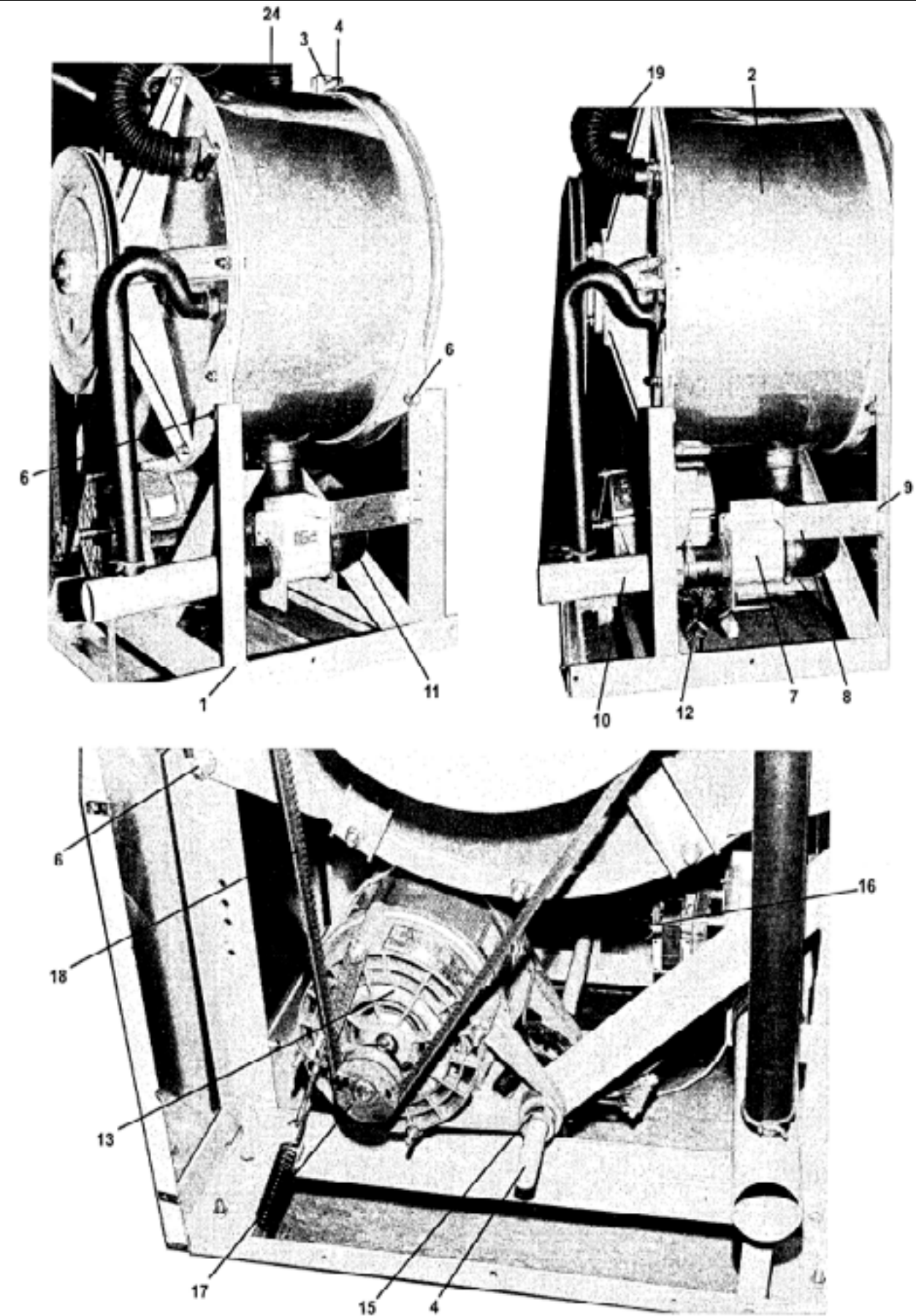

Water Inlet & Rear Channel

Key	Part Number	Description	Qty
1	9379-183-001	Valve, Water Inlet (see Water Inlet Valve Breakdown for individual parts)	2
*	9545-008-026	Screw, Valve Mtg	4
*	8640-399-009	Nut, Spring	4
2	9610-001 001	Vacuum Breaker	1
*	9029-065-001	Bracket, Vacuum Breaker	1
*	9545-008-026	Screw	4
3	9242-458-001	Hose, Vacuum Breaker to Tub	1
4	8654-117-014	Clamp, Vacuum Breaker End	1
*	8654-117-009	Clamp, Tub End	1
5	9242-453-0 0	Hose, Hot Valve to Vac. Brkr 18"	1
6	9242-453-020	Hose, Hot Valve to Vac. Brkr 18"	1
7	9242-453-020	Hose, Cold Valve to Vac. Brkr 18"	1
8	9242-453-020	Hose, Cold Valve to Vac. Brkr 18"	1
9	9242-453-015	Hose, Vac. Brkr. to Rinse Disp.12 5/16"	1
10	9242-453-016	Hose, Vac. Brkr. to Wash Disp.14 1/2"	1
11	8654-117-015	Clamp, Hose-Worm	12
*	5198-211-004	Circuit Breaker, 3 Phase	1
*	5198-211-002	Circuit Breaker, 1 Phase	1
12	9242-450-002	Hose, Dispenser to Tub	1
13	8654-117-008	Dispenser Clamp	2
14	9242-463-001	Overflow hose 9"	1
15	9081-099-001	Channel, Rear	1
16	9122-005-004	Dispenser	1
*	9206-416-001	Gasket, Dispenser	1

*Not illustrated

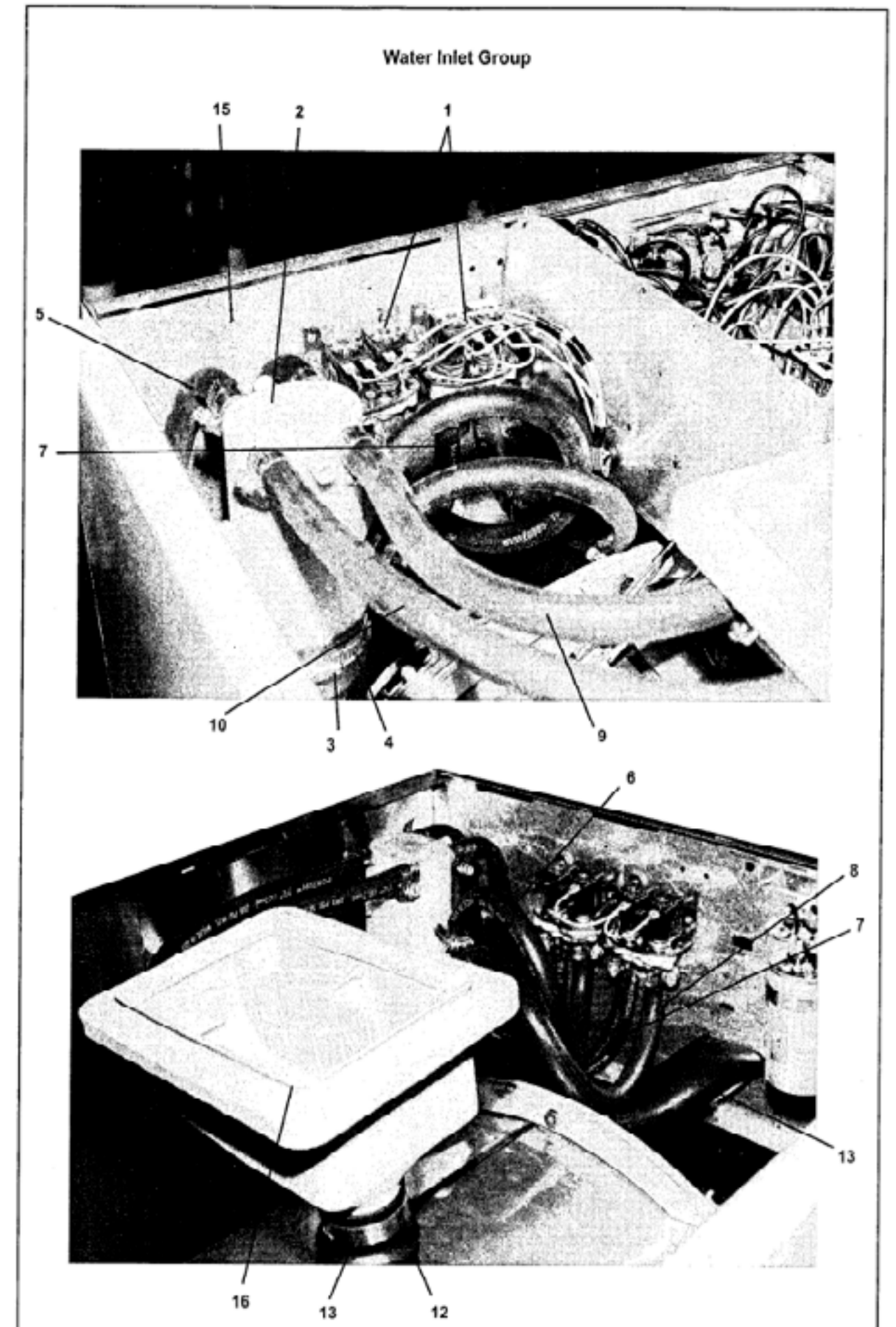

Electrical Components - Top Compartment

WCN18AA - Single Phase Only

Key	Part Number	Description	Qty
1	9575-034-001	Trough Assy, Mtg	1
*	9857-125-007	Control Assy	
*	9545-008-026	Screw, Trough Sides	2
*	9802-037-007	Service Cord ass'y	1
2	5191-103-007	Capacitor, Spin-Start	2
3	5191-103-006	Capacitor, Run-Tumble	1
*	5192-103-008	Capacitor, Run-Tumble	1
4	9544-055-003	Strap, Capacitor Mtg	1
*	9545-045-001	Screw, Capacitor Strap	2
5	5192-286-008	Relay,	1
7	9571-362-001	Timer, Program	1
(VERIFY PART NUMBER ON TIMER BODY)			
*	9376-295-002	Motor, Timer Main Drive	1
*	9376-286-004	Motor, Timer Rapid Advance	1
*	9545-012-001	Screw, Timer Mtg	2
8	9107-068-001	Dial, Timer (Decal)	1
9	9307-176-001	Knob, Timer (w/set screws)	1
10	9571-360-001	Timer, Reversing	1
*	9545-044-004	Screw, Reversing Timer	2
11	9897-026-001	Terminal Block, Power Connection	1
*	9545-045-002	Screw, Mtg	2
*	8502-619-003	Label, Fusing	1
13	8711-003-001	Transformer, (For Accumulator)	1
*	9545-045-001	Screw, Transformer Mtg	2
*	8641-582-005	Lockwasher	2
14	9539-457-001	Switch, Pressure	1
*	9545-045-001	Screw, Mtg	2
15	5198-211-002	Circuit Breaker, 7 amp	1
*	9483-002-001	Resistors, Motorstart	2

* Not Illustrated

Electrical Components-Top Compartment-1 Phase
(1 phase control trough)

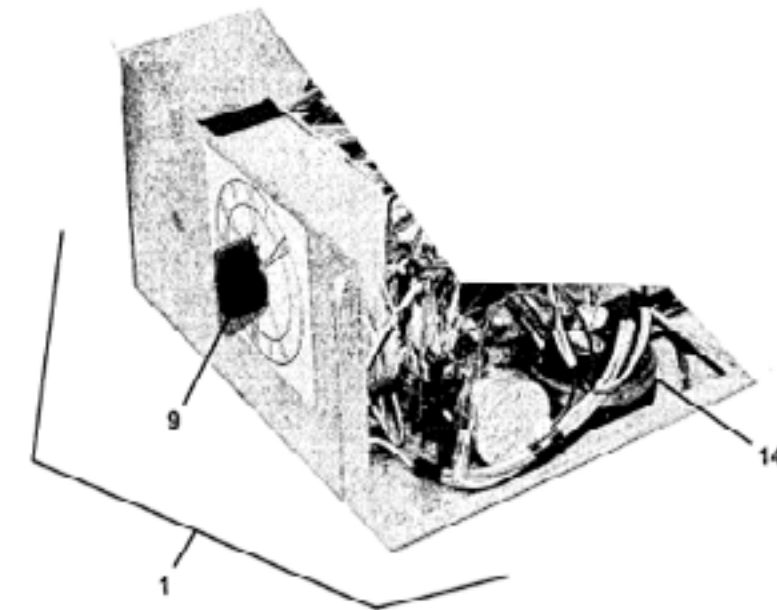
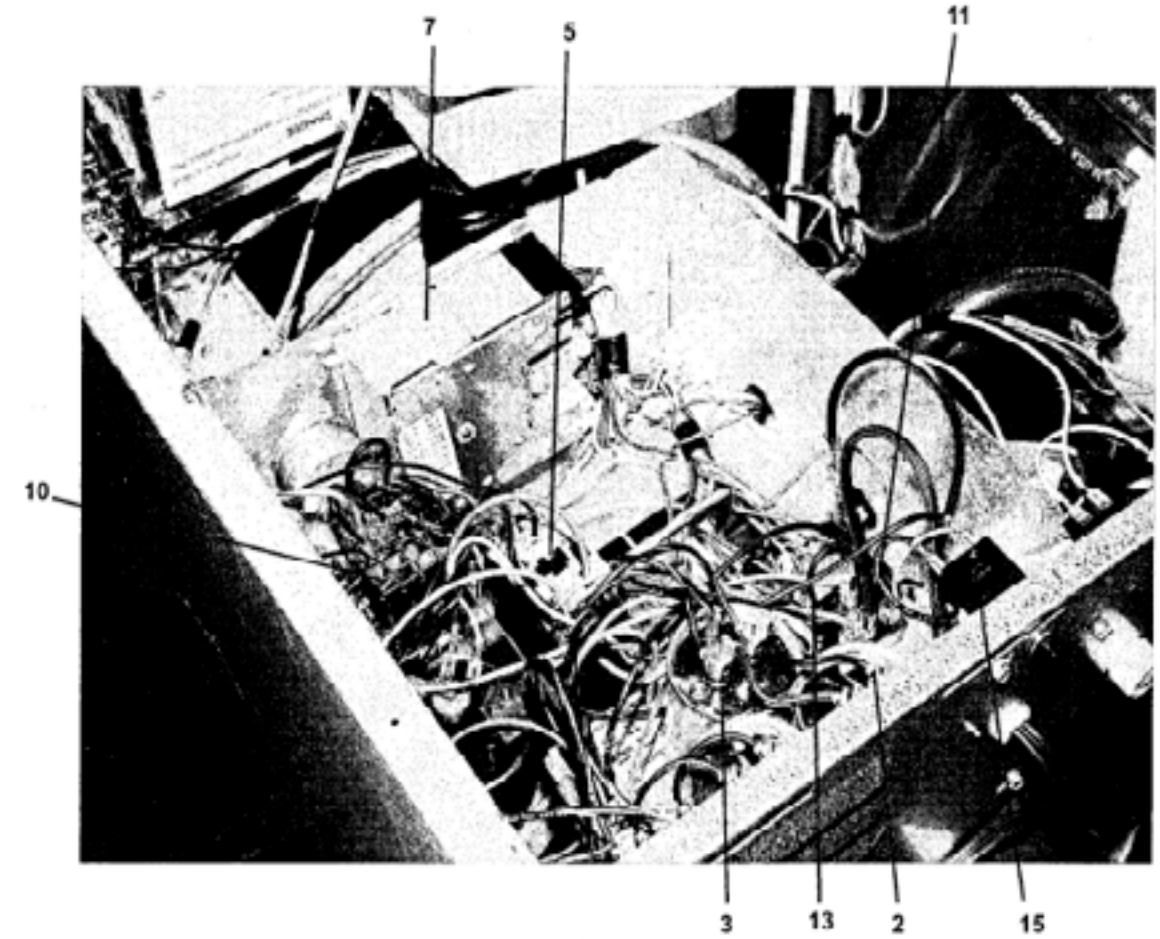

Control Panel Part # by Model Vended WCN18AA/AB

Key	Part Number	Description	Qty
1	3310-042-001	Light, Bleach	1
2	3310-041-001	Light, Cycle Control	1
*	9206-100-001	Gasket, Light	2
3	9539-479-009	Switch, Push-button (cycle selector)	1
*	9412-074-003	Label, Complete (DOUBLE LOAD)	1
*	8640-412-005	Nut, Switch Mtg	2
*	9545-031-011	Screws # 6Tx 5/16	4
4	9021-001-010	Acceptor, Coin	1
*	9545-020-004	Screw, Acceptor Mtg	4
*	8640-424-002	Nut.	4
*	9627-682-001	Harness, Coin Accumulator Wiring.	1
*	9732-126-001	Switch, Coin	1
5	9029-073-001	Bracket, Solenoid (see Door Lock Group for breakdown)	1
6	9020-005-001	Accumulator, Coin	1
7	9538-157-003	Spacer	3
8	8640-412-005	Nut, Hx	6
9	9550-174-001	Shield, Circuit Board	1
10	9242-450-002	Hose, Dispenser to Tub	1
*	8654-117-008	Clamp	2
11	9029-066-001	Side Panel to Tub Front Bracket	1

*Not illustrated

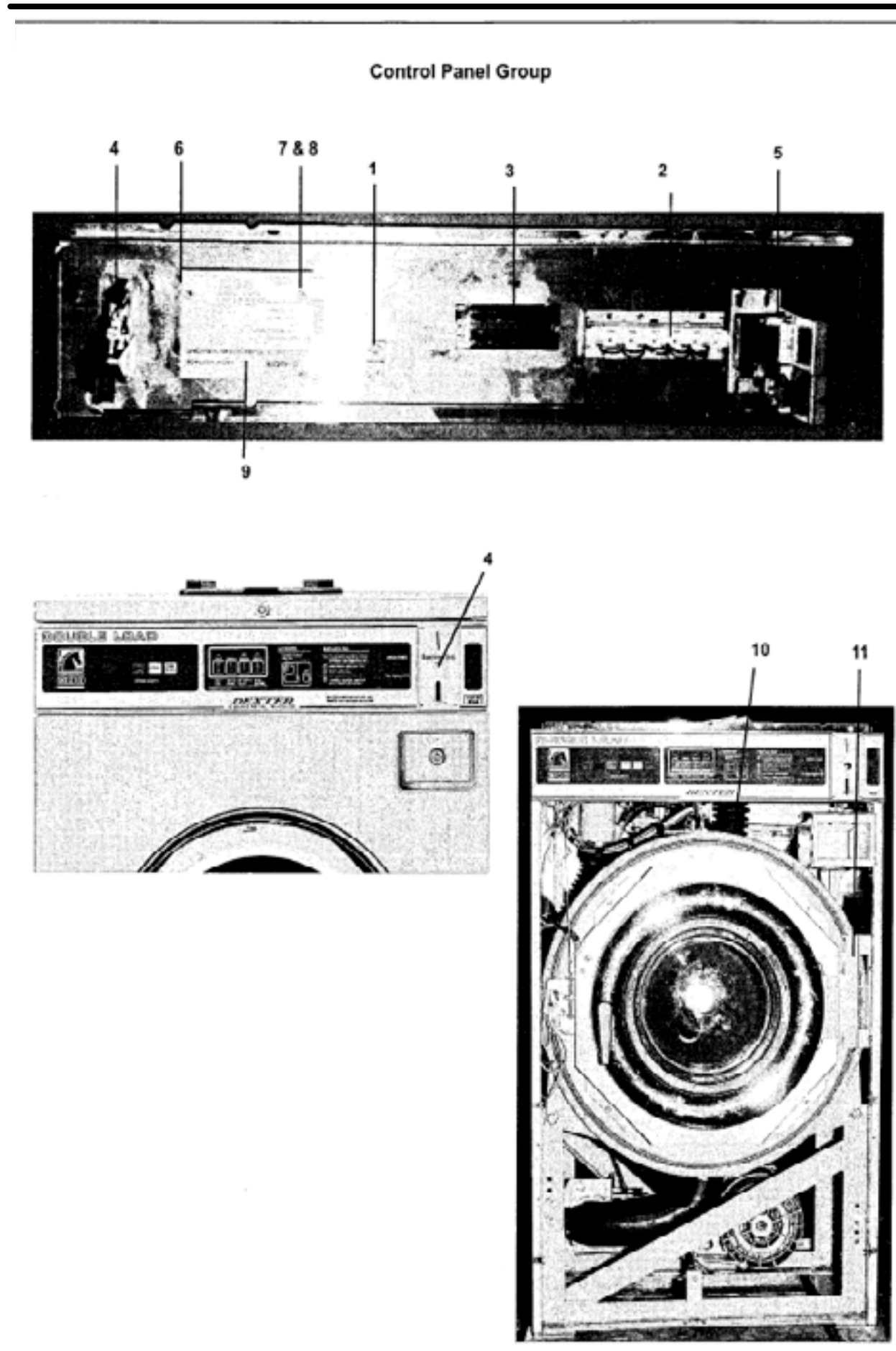

Control Panel Part # by Model OPL WCN18AADX/ABDX

Key	Part Number	Description	Qty
2	9532-140-010	Primary Seal Vringa (opl epdm)	1
3	9539-471-001	Rotary Switch	1
4	9539-474-001	Rocker Switch Red	1
5	9539-474-002	Rocker Switch Wht.	1
6	9452-595-001	Switch Mounting Plate	1
7	9:A5-045-001	Screws-8Bx1/4"	6
*	8640-412-005	Nuts Hex-keps 8/32	6
*	9627-674-001	Wiring Harness OPL manual	1
*	8220-001-235	Wire Org./Wht.	2
*	8220-001-377	Wire Wht./Grn	1
8	9307-176-001	Knob	1
9	8502-651-001	Label Nameplate OPL	1
10	8502-615-002	Label Switch Mounting Plate	1
11	9454-668-002	Front Panel w/out coin box	1

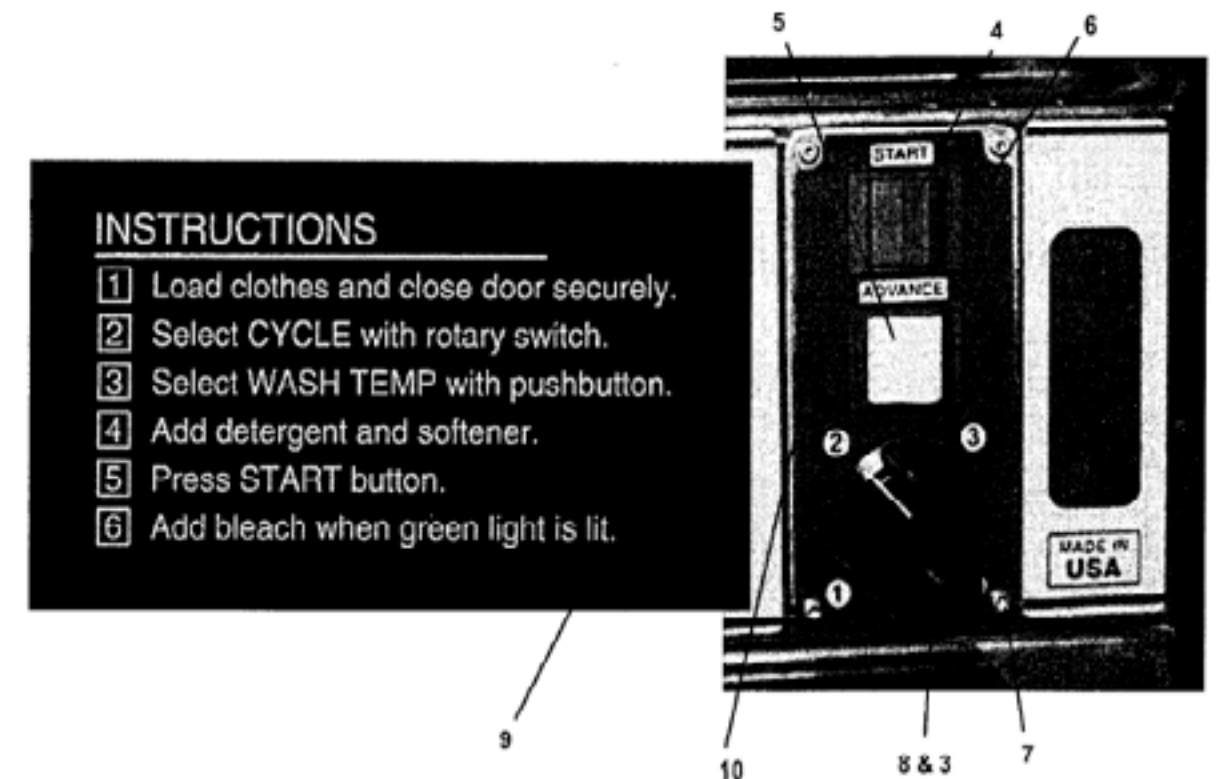
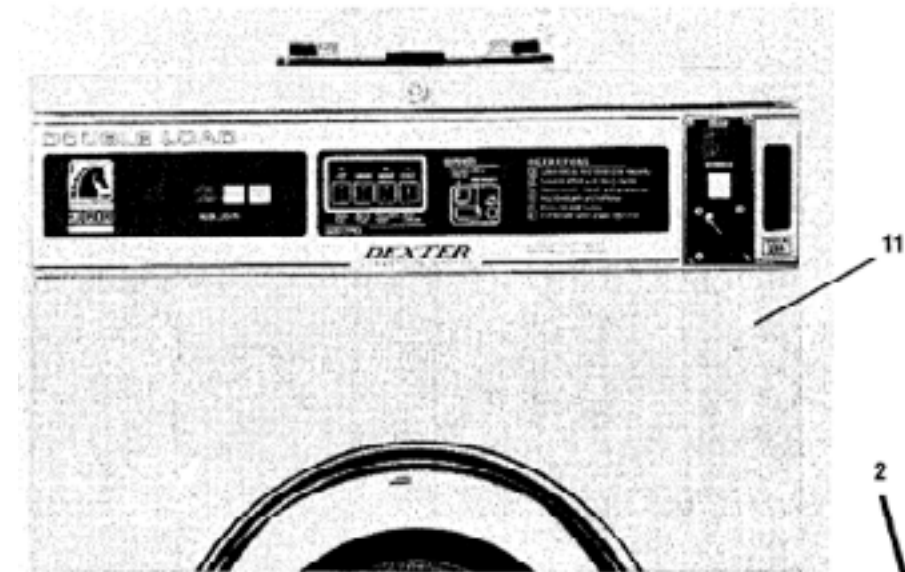

INSTRUCTIONS

- 1 Load clothes and close door securely.
- 2 Select CYCLE with rotary switch.
- 3 Select WASH TEMP with pushbutton.
- 4 Add detergent and softener.
- 5 Press START button.
- 6 Add bleach when green light is lit.

Labels and Diagrams WCN Models

Vended WCN18AA/AB

8502-620-001 Label-Motor connection, Single Phase
8502-622-002 Label—Nameplate, Single Phase
8502-619-003 Label—Fusing & Installation, Single Phase
8502-619-004 Label-Fusing & Installation, 3 Phase
8502-614-004 Label--Warning, High voltage (Single Phase)
8502-624-002 Label---Warning, Door opening (Single Phase)
8507-273-001 Instructions---SPIN direction, Single Phase
8511-001-002 Label---QUALITY, Single Phase
9345-790-002 Label Wiring Schematic, Single Phase
9345-791-002 Label--Wiring Diagram, Single Phase
9345-792-001 Label--Wiring Schematic, 3 Phase
9345-793-002 Label--Wiring Diagram, 3 Phase
8507-230-001 Instructions-Transformer Connections, 3 Phase

OPL WCN18AADX/ABDX

8502-651-001 Label-Nameplate OPL
8502-615-002 Label-Switch Mounting Plate
9345-814-002 Wiring Schematic, Single Phase
9345-815-002 Wiring Diagram, Single Phase
9345-816-001 Wiring Schematic, Three Phase
9345-817-002 Wiring Diagram, Three Phase

Section 7:

Coin Handling Parts

Coin Handling Group

Key	Part Number	Description	Qty
*	9942-024-007	Vault, Assy	1
*	9545-008-026	Screw, Vault Mtg	4

NOTE: COIN BOX AND HARDWARE KIT AND COIN BOX LOCK NOT INCLUDED WITH MACHINE.

2	9732-122-001	Kit, Coin Box W/Hardware(#2-#6)	1
3	9349-033-001	Latch, Coin Box	1
4	8641-569-002	Washer, Wave	1
5	8641-583-001	Washer, Keeper	1
6	8641-581-008	Washer, Spacer- Thick	2
6	8641-581-010	Washer, Spacer- Thin	4
7	8650-012-003	Lock, Coin Box (w/key not included with 9732-122-001)	1
8	9021-001-010	Acceptor, Coin	1
*	9545-020-004	Screw, Acceptor Mtg	4
*	8640-424-002	Nut.	4
9	9732-126-001	Switch, Coin	1
10	9119-025-002	Acceptor Chute Assy w/o Penny Rejector (standard)	1
11	9486-133-001	Button Coin Returner Retainer	1
12	9119-025-001	Acceptor Chute Assy w/ Penny Rejector (optional)	1

*Not illustrated

