







***DEXTER***<sup>®</sup>  
***LAUNDRY***

**USE THE BLUE TABS LOCATED ON THE  
RIGHT AND LEFT SIDES OF THE FOLLOWING  
DOCUMENT TO ADVANCE TO EACH SECTION.**



Dexter Commercial Vended Dryer  
Parts & Service Manual

## Equipment Safety Warnings Symbols and Terminology Used in this Equipment

<b>⚠ DANGER</b>	Indicates an imminently hazardous situation, which if not avoided, will result in death or serious injury.
<b>⚠ WARNING</b>	Indicates a potentially hazardous situation, which if not avoided could result in death or serious injury.
<b>⚠ CAUTION</b>	Indicates a potentially hazardous situation which, if not avoided, may result in minor or moderate injury. It may also be used to alert against unsafe practices. Minor burns, pinch points that result in bruises and minor chemical irritation.
<b>NOTICE</b>	Indicates information or a company policy that relates directly or indirectly to the safety of personnel or protection of property.
	This is the user caution symbol. It indicates a condition where damage to the equipment resulting in injury to the operator could occur if operational procedures are not followed. <b>TO REDUCE THE RISK OF DAMAGE OR INJURY, refer to accompanying documents; follow all steps or procedures as instructed.</b>
	This is the electrical hazard symbol. It indicates that there are <b>DANGEROUS HIGH VOLTAGES PRESENT</b> inside the enclosure of this product. <b>TO REDUCE THE RISK OF FIRE OR ELECTRIC SHOCK, do not attempt to open the enclosure or gain access to areas where you are not instructed to do so. REFER SERVICING TO QUALIFIED SERVICE PERSONEL ONLY</b>
	<b>Caution! There are sharp edges on various sheet metal parts internal to the enclosure. Use safety consciousness when placing or moving your hands while working in the interior of this equipment.</b>
	<b>Caution! To reduce the risk of damage to the Water Inlet Valve, do not supply inlet water with a temperature that exceeds 70° C.</b>  <b>Caution! To reduce the risk of fire or explosion, do not operate this equipment in any hazardous classified (ATEX) environment.</b>

## Equipment Safety Warnings

### Symbols and Terminology Used in this Equipment



Warning! Do not operate equipment if door glass is damaged in any way.



Warning! Keep clear of rotating parts.



Prohibited! Do not enter this equipment or space.



Prohibited! Do not step or stand on this equipment.



Prohibited! Do not operate without all guards and covers in place.









Prohibited! Do not operate without all guards and covers in place.



Prohibited! Do not wash or Dry clothing impregnated with flammable liquids (petrochemical).



Prohibited! Do not allow children to play in or around equipment.

	<b>DANGER</b> Indicates an imminently hazardous situation, which if not avoided, <u>will result</u> in death or serious injury.
	<b>WARNING</b> Indicates a potentially hazardous situation, which if not avoided <u>could result</u> in death or serious injury.
	<b>CAUTION</b> Indicates a potentially hazardous situation which, if not avoided, <u>may result</u> in minor or moderate injury. It may also be used to alert against unsafe practices. Minor burns, pinch points that result in bruises and minor chemical irritation.
	<b>NOTICE</b> Indicates information or a company policy that relates directly or indirectly to the safety of personnel or protection of property.
	This is the user caution symbol. It indicates a condition where damage to the equipment resulting in injury to the operator could occur if operational procedures are not followed. <b>TO REDUCE THE RISK OF DAMAGE OR INJURY, refer to accompanying documents; follow all steps or procedures as instructed.</b>
	This is the electrical hazard symbol. It indicates that there are <b>DANGEROUS HIGH VOLTAGES PRESENT</b> inside the enclosure of this product. <b>TO REDUCE THE RISK OF FIRE OR ELECTRIC SHOCK, do not attempt to open the enclosure or gain access to areas where you are not instructed to do so. REFER SERVICING TO QUALIFIED SERVICE PERSONEL ONLY</b>
	Caution! To reduce the risk of fire or explosion, do not operate this equipment in any hazardous classified (ATEX) environment.



## WARNING

	<ul style="list-style-type: none"> <li>• All Dryers must be installed in accordance to all applicable electrical, plumbing and all other local codes.</li> <li>• These installation and operation instructions are for use by qualified personnel only. To avoid injury and electrical shock, do not perform any servicing other than that contained in the installation and operation instructions, unless qualified.</li> </ul>
	Do not install Equipment in an explosive atmosphere.
	<ul style="list-style-type: none"> <li>• Care must be stressed with all foundation work to ensure a stable unit installation, eliminating possibilities of excessive vibration.</li> <li>• Foundation must be level within 13 mm to ensure proper washer operation.</li> </ul>
	Do not operate washer or Dryer if door glass is damaged in any way.
	Do not wash or Dry clothing impregnated with flammable liquids (petrochemical).



## WARNING





 	Children should be supervised to ensure they do not operate or play in or around equipment.
	Keep all panels in place to protect against electrical shock and injury and add rigidity to washer.

This appliance is not intended for use by persons (including children) with reduced physical, sensory or mental capabilities, or lack of experience and knowledge, unless they have been given supervision or instruction concerning use of the appliance by a person responsible for their safety.

A washer should not be allowed to operate if any of the following occur:

- Excessive high water level.
- Machine is not connected to a properly earthed circuit.
- Door does not remain securely locked during the entire cycle.
- Vibration or shaking from an inadequate mounting or foundation

	<b>Warning! Do not operate equipment if door glass is damaged in any way.</b>
	<b>Warning! Keep clear of rotating parts.</b>
	<b>Prohibited! Do not enter this equipment or space.</b>
	<b>Prohibited! Do not step or stand on this equipment.</b>
	<b>Prohibited! Do not operate without all guards and covers in place.</b>
	<b>Prohibited! Do not operate without all guards and covers in place.</b>
	<b>Prohibited! Do not wash or Dry clothing impregnated with flammable liquids (petrochemical).</b>
	<b>Prohibited! Do not allow children to play in or around equipment.</b>

	<b>Prohibited! Do not attempt to open, touch, or proceed before referring to the manual or unless qualified.</b>
	<b>Mandatory! Read all supporting documentation before operating or maintaining equipment.</b>
	<b>Mandatory! Disconnect power before servicing equipment.</b>
	<b>Mandatory! Lock out and tag out before servicing this equipment.</b>
	<b>Mandatory! Children should be supervised to ensure they do not operate equipment.</b>



# Section 1:

## Dryer

### Specifications & Installation

## Machine Specifications: 30Lb

### Dimensions / Capacity

Dry Weight Capacity - lb (kg)	30 lb	(13.6 kg)
Cabinet Height - in (cm)	72.63"	(184.3 cm)
Cabinet Width - in (cm)	31.5"	(80.0 cm)
Overall Depth - in (cm)	42.0"	(107.0 cm)
Door Opening - in (cm)	22.69"	(57.6 cm)
Cylinder Diameter - in (cm)	30"	(76.2 cm)
Cylinder Depth - in (cm)	27.5"	(69.9 cm)
Cylinder Volume - cu.ft. (liters)	11.25 cu.ft.	(318.6 l)
Tumbler Speed	47 RPM	

### Airflow - cfm (M3/min)

60Hz	830 cfm	(23.5 M3/ min)
50Hz	690 cfm	(19.5 M3/min)
Lint Screen Area	515 sq.in.	(3323 sq.cm)
Net Weight - lb (kg)	463 lbs	(210.2 kg)

### Shipping Dimensions:

Shipping Weight	507 lbs	(230.9 kg)
Height - in (cm)	78.0"	(195.0 cm)
Width - in (cm)	32.75"	(83.19 cm)
Depth - in (cm)	45.5"	(115.6 cm)

### BTU's /Circuit Breaker / Running Amps / Wire Size

#### Gas Models

60Hz	90,000 BTU/hr	(26.4 kW)
50Hz	80,000 BTU/hr	(23.4 kW)
Gas Supply Connection	0.5"	(12.7 mm)
Natural Gas Supply - (water column)	5 - 10"	(12.7 - 25.4 cm)
Manafold	3.5" Max	(8.9 cm)
LP Gas Supply - (water column)	11 - 13.5"	(27.9 - 34.3 cm)
Manafold	11"	(27.9 cm)

#### Gas

-10 (120/60/1 - 2 wire + ground)	15 amp / 9.6amp / #12
-39 (230/50/1 - 2 wire + ground)	10 amp / 5.1amp / #14

#### Electric (per pocket)

-64FN (400/50/3 - 4 wire + ground) - 24kW	50 amp / 45 amp / # 6
---	-----------------------

#### Installation Recommendations

Clearance Behind Machines	18"	(45.7 cm)
Make-up Air Req. (per dryer)	1.0 sq.ft.	(929 sq.cm)
Exhaust Size - in (cm)	8"	(20.3 cm)

## Machine Dimensions: 30Lb

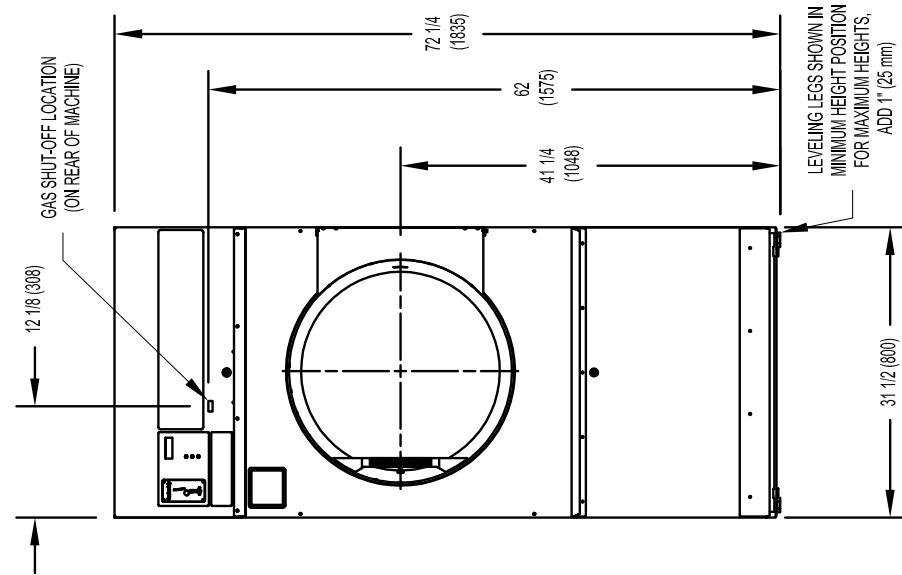

T30 COMMERCIAL DRYER  
MOUNTING DIMENSIONS

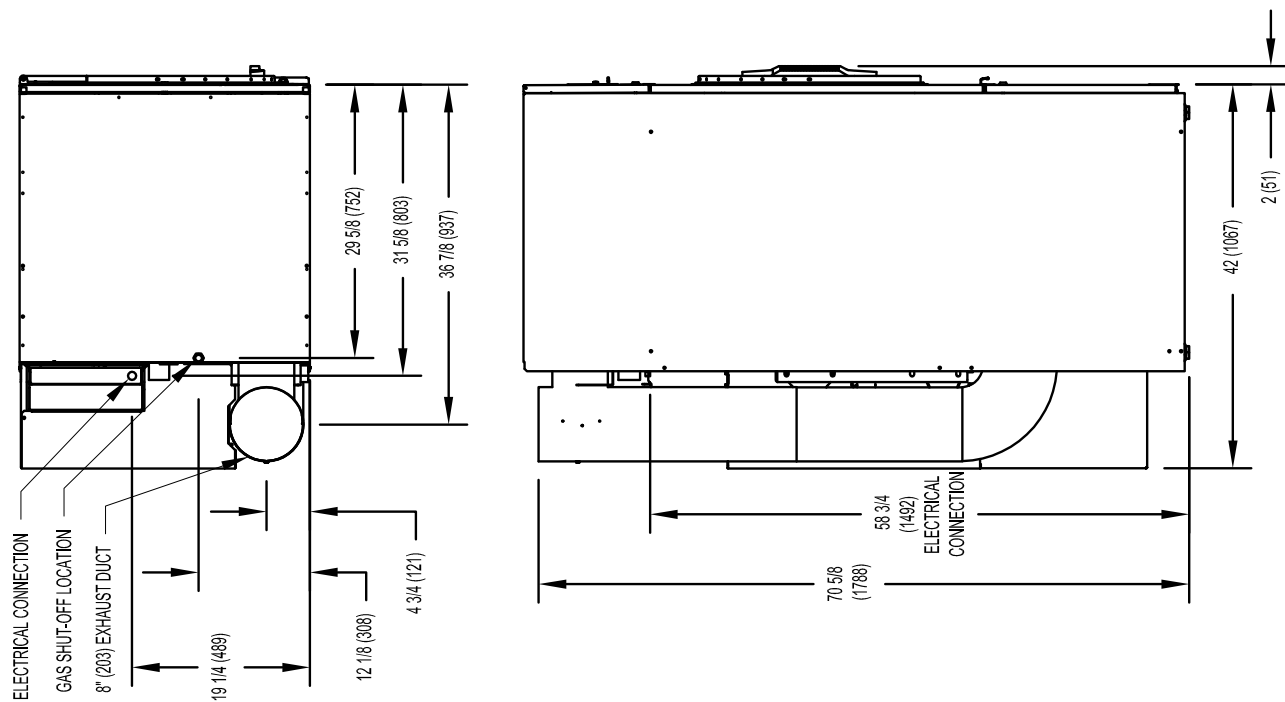

## Machine Specifications: 50Lb

### Dimensions / Capacity

Dry Weight Capacity - lb (kg)	50 lb	(24.9 kg)
Cabinet Height - in (cm)	72.63"	(184.3 cm)
Cabinet Width - in (cm)	34.5"	(87.6 cm)
Overall Depth - in (cm)	48.0"	(121.9 cm)
Door Opening - in (cm)	26.0"	(66.0 cm)
Cylinder Diameter - in (cm)	32.5"	(82.6 cm)
Cylinder Depth - in (cm)	33.0"	(84.5 cm)
Cylinder Volume - cu.ft. (liters)	15.84.2 cu.ft.	(449.5 l)
Tumbler Speed	45 RPM	

### Airflow - cfm (M3/min)

60Hz	830 cfm	(23.5 M3/ min)
50Hz	690 cfm	(19.5 M3/min)
Lint Screen Area	515 sq.in.	(3323 sq.cm)
Net Weight - lb (kg)	463 lbs	(210.2 kg)

### Shipping Dimensions:

Shipping Weight	611 lbs	(277.0 kg)
Height - in (cm)	78.0"	(198.1 cm)
Width - in (cm)	36"	(91.44 cm)
Depth - in (cm)	54.5"	(138.4 cm)

### BTU's / Circuit Breaker / Running Amps / Wire Size

#### Gas Models

60Hz	145,000 BTU/hr (26.4 kW)
50Hz	120,000 BTU/hr (23.4 kW)
Gas Supply Connection	0.5" (12.7 mm)
Natural Gas Supply - (water column)	5 - 10" (12.7 - 25.4 cm)
Manifold	3.5" Max (8.9 cm)
LP Gas Supply - (water column)	11 - 13.5" (27.9 - 34.3 cm)
Manifold	11" (27.9 cm)

#### Gas

-10 (120/60/1 - 2 wire + ground)	15 amp / 9.6amp / #12
-39 (230/50/1 - 2 wire + ground)	10 amp / 5.1amp / #14

#### Electric (per pocket)

-64FN (400/50/3 - 4 wire + ground) - 24kW	50 amp / 45 amp / # 6
---	-----------------------

### Installation Recommendations

Clearance Behind Machines	18"	(45.7 cm)
Make-up Air Req. (per dryer)	1.0 sq.ft.	(929 sq.cm)
Exhaust Size - in (cm)	8"	(20.3 cm)

## Machine Dimensions: 50Lb

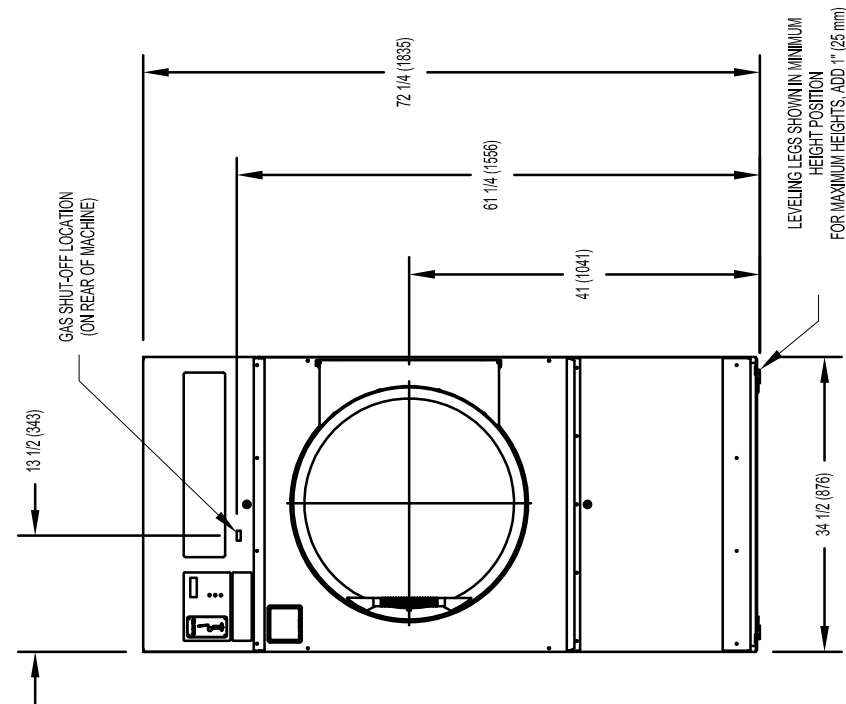

T50 COMMERCIAL DRYER  
MOUNTING  
DIMENSIONS

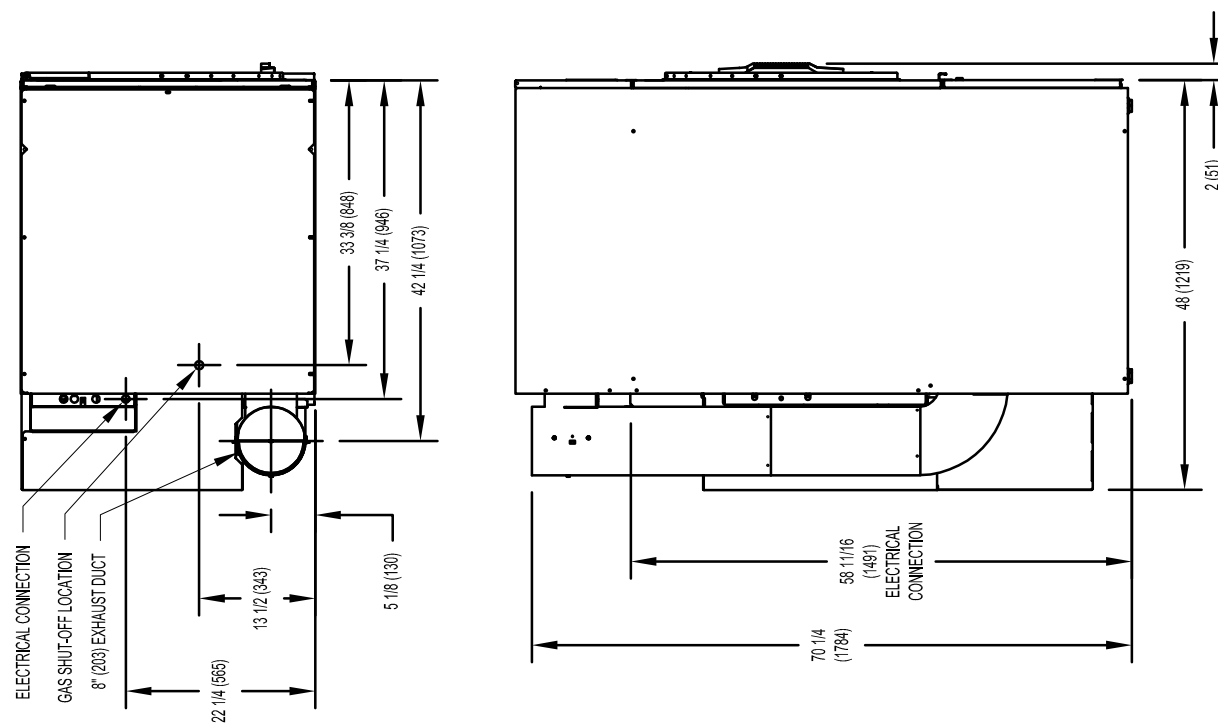

## Machine Specifications: 80Lb

### Dimensions / Capacity

Dry Weight Capacity - lb (kg)	80 lb	(36.3 kg)
Cabinet Height - in (cm)	76"	(193.0 cm)
Cabinet Width - in (cm)	38.38"	(97.5 cm)
Overall Depth - in (cm)	51.63"	(131.1 cm)
Door Opening - in (cm)	26"	(66.0 cm)
Cylinder Diameter - in (cm)	36.5"	(92.7 cm)
Cylinder Depth - in (cm)	38"	(96.5 cm)
Cylinder Volume - cu.ft. (liters)	23.0 cu.ft.	(651.3 l)
Tumbler Speed	40 RPM	

### Airflow - cfm (M3/min)

60Hz	1200 cfm	(34.0 M3/min)
50Hz	1000 cfm	(28.3 M3/min)
Lint Screen Area	823 sq.in.	(5310.0 sq.cm)
Net Weight - lb (kg)	699 lbs	(291.2 kg)

### Shipping Dimensions:

Shipping Weight	729 lbs	(331.2 kg)
Height - in (cm)	81.0"	(205.7 cm)
Width - in (cm)	40.25"	(102.2 cm)
Depth - in (cm)	55.5"	(141.0 cm)

### BTU's /Circuit Breaker / Running Amps / Wire Size

#### Gas Models

60Hz	215,000 BTU/hr (26.4 kW)
50Hz	195,000 BTU/hr (23.4 kW)
Gas Supply Connection	0.5" (12.7 mm)
Natural Gas Supply - (water column)	5 - 8" (12.7 - 20.3 cm)
Manifold	3.5" Max (8.9 cm)
LP Gas Supply - (water column)	11 - 13.5" (27.9 - 34.3 cm)
Manifold	11" (27.9 cm)

#### Gas

-10 (120/60/1 - 2 wire + ground)	15 amp / 9.6amp / #12
-39 (230/50/1 - 2 wire + ground)	10 amp / 5.1amp / #14

#### Electric (per pocket)

-64FN (400/50/3 - 4 wire + ground) -	24kW 50 amp / 45 amp / #6
--------------------------------------	---------------------------

### Installation Recommendations

Clearance Behind Machines	18"	(45.7 cm)
Make-up Air Req. (per dryer)	1.5 sq.ft.	(1394 sq.cm)
Exhaust Size - in (cm)	8"	(20.3 cm)

## Machine Dimensions: 80Lb

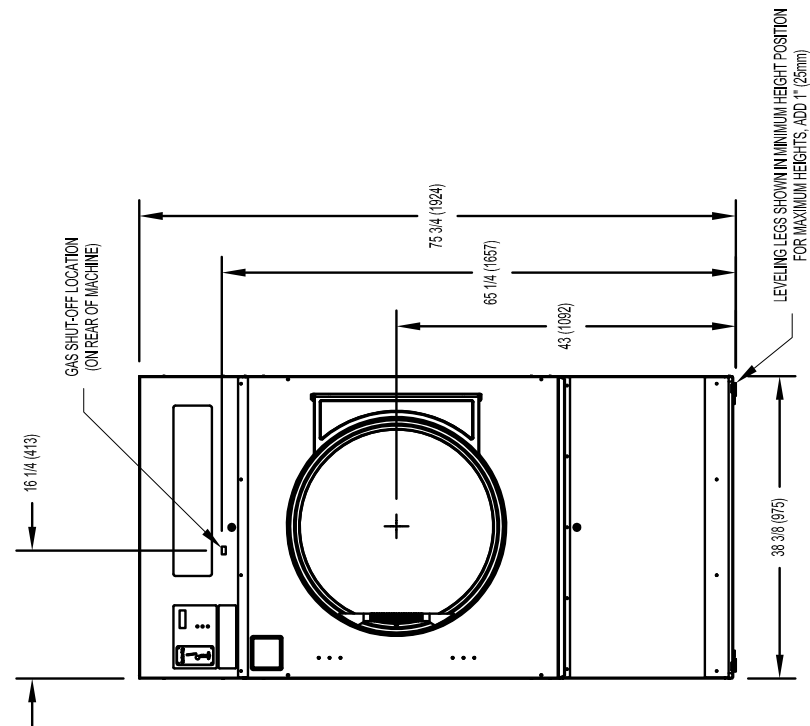

### T80 COMMERCIAL DRYER MOUNTING DIMENSIONS

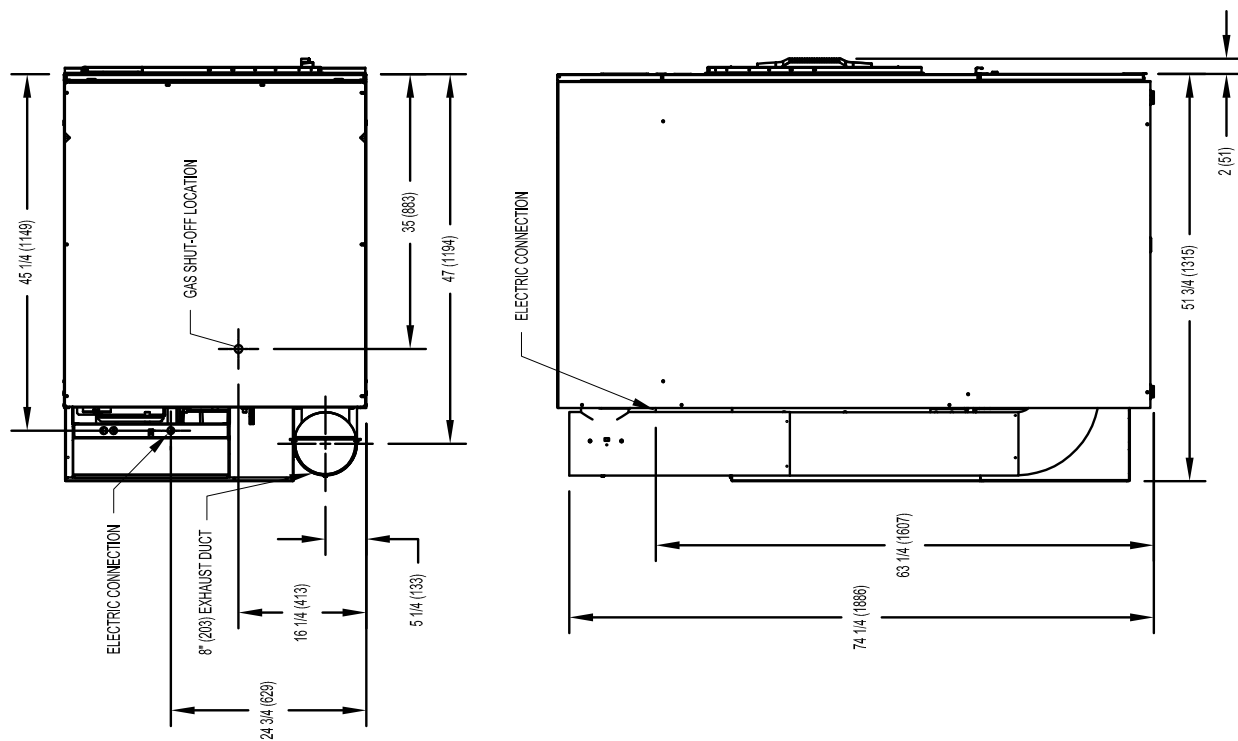

## Dryer Installation

All commercial dryer installations must conform with local applicable local codes or in the absence of local codes, with the National Fuel Gas Code ANSI Z223.1A-1988. Canadian installations must comply with current standard CAN/CGA-B149(.1 or .2) Installation Code for Gas Burning Appliances or Equipment, and local codes if applicable. The appliance, when installed, must be electrically grounded in accordance with the National Electric Code, ANSI/NFPA No. 70-1990, or when installed in Canada, with Standard CSA C22.1 Canadian Electrical Code Part 1.

### Installation Clearances:

This unit may be installed at the following alcove clearances. (millimeters)

1. Left side- 0"
2. Right side- 0" \*
3. Back- 18" (457) (Certified for 1" (25) clearance; however, 18" (457) clearance is necessary behind the belt guard to allow servicing and maintenance.)
4. Front- 48" (1220) (to allow use of dryer)
5. Top- Refer to figure labelled "Vertical Clearance Dimensions". Certification allows 0" clearance at the top 1" (25) back from the front. However, a 1/4" (6) clearance is required to allow opening the upper service door. A 10" (254) clearance is required from the top at all other points.
6. Floor- This unit may be installed upon a combustible floor. \*Units may be installed in direct contact with an adjacent dryer, providing allowance is made for opening upper and lower service doors. Do not obstruct the flow of combustion and ventilation air. Maintain minimum of 1" (25) clearance between duct and combustible material.

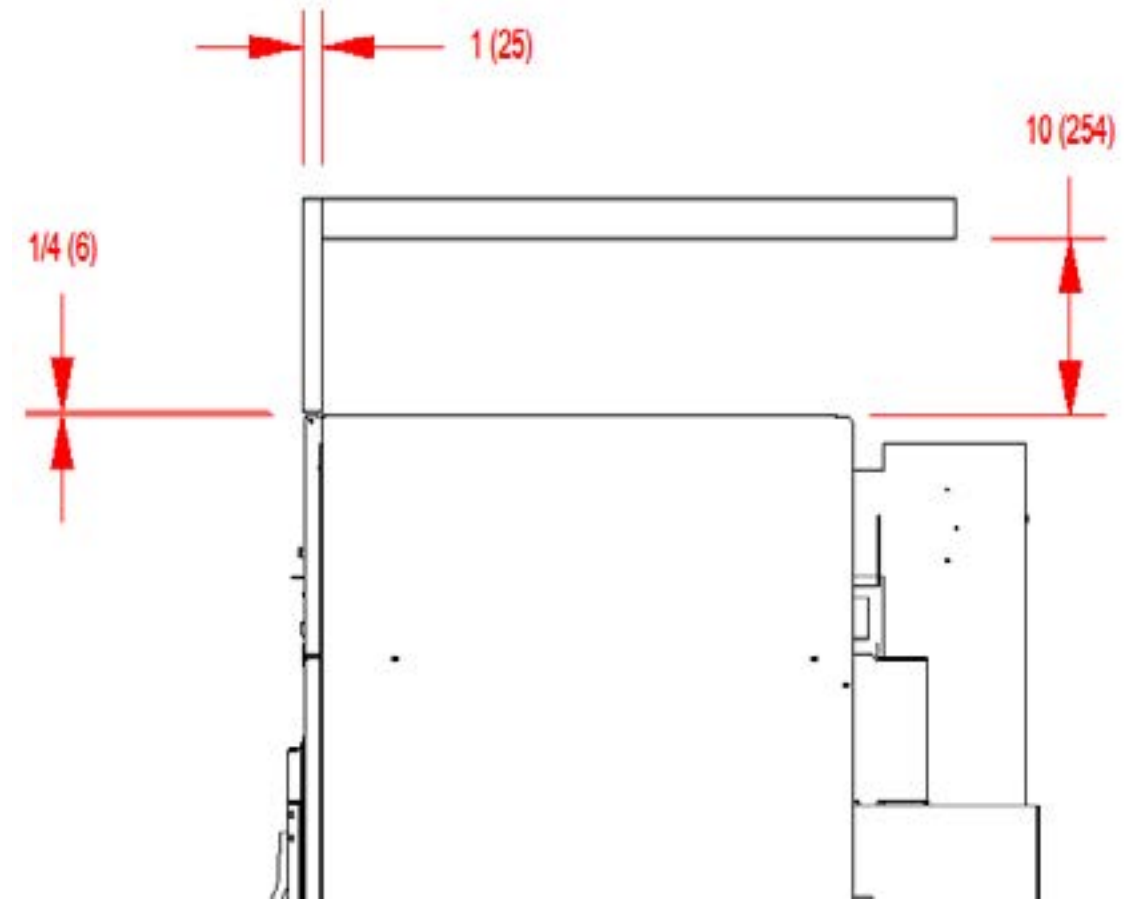

### VERTICAL CLEARANCE DIMENSIONS - ALL DCBD(30/50/80)

## MAKE-UP AIR

Adequate make-up air must be supplied to replace air exhausted by dryers on all types of installations. Provide a minimum make-up air opening to the outside for each dryer as follows:

Dryer Model	Make-up Air Volume/Time	Make-up Air Opening Area (minimum)
DCBD30KC_-10	830 CFM (23.5 m3/minute)	1 ft <sup>2</sup> (0.10 m <sup>2</sup> )
DCBD30KC_-39	690 CFM (19.5 m3/minute)	1 ft <sup>2</sup> (0.10 m <sup>2</sup> )
DCBD50KC_-10	850 CFM (23.5 m3/minute)	1.25 ft <sup>2</sup> (0.12 m <sup>2</sup> )
DCBD50KC_-39	700 CFM (19.8 m3/minute)	1.25 ft <sup>2</sup> (0.12 m <sup>2</sup> )
DCBD80KC_-10	1200 CFM (34.0 m3/minute)	1.5 ft <sup>2</sup> (0.14 m <sup>2</sup> )
DCBD80KC_-39	1000 CFM (28.3 m3/minute)	1.5 ft <sup>2</sup> (0.14 m <sup>2</sup> )

This is a net requirement of effective area. Screens, grills or louvers, which will restrict the flow of air, must be considered. Consult the supplier to determine the free area equivalent for the grill being used. The source of make-up air should be located sufficiently away from the dryers to allow an even airflow to the airintakes of all dryers. Multiple openings should be provided.

**NOTE:** The following considerations must be observed for gas dryer installations where dry cleaners are installed. The sources of all make-up air and room ventilation air movement to all dryers must be located away from any dry cleaners. This is necessary so that solvent vapors will not be drawn into the dryer inlet ducts. Dry cleaner solvent vapors will decompose in contact with an open flame such as the gas flame present in clothes dryers. The decomposition products are highly corrosive and will cause damage to the dryer(s), ducts and clothes loads.

## ELECTRICAL REQUIREMENTS.

The electrical power requirements necessary to operate the unit satisfactorily are listed on the serial plate located on the back panel of each dryer. The electrical connection should be made to the terminal block in the rear control box assembly on the rear of the unit, using a wire size adequate to handle the amperage and voltage listed on the serial plate, but never smaller than No.12 AWG wire. It is absolutely necessary that the dryer be grounded to a known ground.

Individual circuit breakers for each unit are recommended. The wiring diagram is located on the belt guard on the back of the machine.

## TRANSIENT VOLTAGE SURGE SUPPRESSORS

Like most electrical equipment your new machine can be damaged or have its life shortened by voltage surges due to lightning strikes which are not covered by factory warranty. Local power distribution problems also can be detrimental to the life of electrical components. We recommend the installation of transient voltage surge suppressors for your new equipment. These devices may be placed at the power supply panel for the complete installation and don't require an individual device for each machine.

These surge protectors help to protect equipment from large spikes and also from small ongoing spikes in the power that occur on a day to day basis. These smaller surges can shorten overall life of electrical components of all types and cause their failure at a later date. Although they can't protect against all events, these protective devices have a good reputation for significantly lengthening the useful life of electronic components.

Electronic Components are helped to have a longer useful life when they are supplied with the clean stable electrical power they like.

We are including the following names and links to a few suppliers of these devices for those who don't currently have a source.

## TVSS

### MANUFACTURERS

Innovative Technology, Inc

### CONTACT

(Eaton) Factory

### PHONE

1-800-647-8877 or www.itvss.com

EFI Electronics Corporation  
(Schneider Electric)

Factory  
Distributor – Surge Pro

1-800-877-1174 or www.efinet.com  
1-877-233-0153

MCG Surge Protection

Factory

1-800-851-1508 or www.mcgsurge.com

Advanced Protection  
Technologies Inc.

Factory

1-800-237-4567 or www.aptsurge.com

## GAS REQUIREMENTS.

The complete gas requirements necessary to operate the dryer satisfactorily are listed on the serial plate located on the back panel of the dryer. The inlet gas connection to the unit is 1/2 inch pipe thread. A joint compound resistant to the action of liquefied petroleum gases should be employed in making pipe connections. A 1/8 inch NPT plugged tapping, accessible for test gage connection, must be installed immediately upstream of the gas supply connection to the dryer. A drip tee should be provided in the gas piping entering the unit to catch dirt and other foreign articles. All pipe connections should be checked for leakage with soap solution. Never check with an open flame. For altitudes above 2,000 feet (610m) it is necessary to derate the BTU input. Contact your local distributor for instructions. L.P. gas conversion kits are available for this dryer. Contact your local distributor.

**CAUTION:** The dryer and its individual shutoff valve must be disconnected from the gas supply piping system during any pressure testing of that system at test pressures in excess of 1/2 psig. The dryer must be isolated from the gas supply piping system by closing its individual manual shutoff valve during any pressure testing of the gas supply piping system at test pressures equal to or less than 1/2 psig

## Burner Set-Up

All gas burner manifolds should be checked for proper gas pressure while burning. Dryer manifold pressure should be set at 3.5 W.C. for Natural Gas while burner operating.

**EXHAUST INSTALLATION.** (Refer to Figure 2 at the end of section 6.) Exhausting of the dryer(s) should be planned and constructed so that no air restrictions occur. Any restriction due to pipe size or type of installation can cause slow drying time, excessive heat, and lint in the room.

From an operational standpoint, incorrect or inadequate exhausting can cause a cycling of the high limit thermostat which shuts off the main burners and results in inefficient drying.

Individual exhausting of the dryers is recommended. All heat, moisture, and lint should be exhausted outside by attaching a pipe of the proper diameter to the dryer adapter collar and extending it out through an outside wall.

This pipe must be very smooth on the inside, as rough surfaces tend to collect lint which will eventually clog the duct and prevent the dryer from exhausting properly. All elbows must be smooth on the inside. All joints must be made so the exhaust end of one pipe is inside the next one downstream. The addition of an exhaust pipe tends to reduce the amount of air the blower can exhaust. This does not affect the dryer operation if held within practical limits. For the most efficient operation, it is recommended that no more than 20' (6m) of straight 8" diameter pipe be used with two right angle elbows. When more than two elbows are used, 2' (600mm) of straight pipe should be removed for each additional elbow. No more than four right angle elbows should be used to exhaust a dryer.

Maintain minimum 1" (25) clearance between duct and combustible material.

If the exhaust pipe passes through a wall, a metal sleeve of slightly larger diameter should be set in the wall and the exhaust pipe passed through this sleeve. This practice is required by some local codes and is recommended in all cases to protect the wall. This type of installation should have a means provided to prevent rain and high winds from entering the exhaust when the dryer is not in use. A hood with a hinged damper can be used for this purpose. Another method would be to point the outlet end of the pipe downward to prevent entrance of wind and rain. In either case, the outlet should be kept clear, by at least 24" (610), of any objects which would cause an air restriction.

Never install a protective screen over the exhaust outlet. When exhausting a dryer straight up through a roof, the overall length of the duct has the same limits as exhausting through a wall. A rain cap must be placed on top of the exhaust and must be of such a type as to be free from clogging. The type using a cone shaped "roof" over the pipe is suitable for this application.

Exhausting the dryer into a chimney or under a building is not permitted. In either case there is a danger of lint build-up which can be highly combustible.

Installation of several dryers, where a main discharge duct is necessary, will need the following considerations for installation (see Fig. 2). Individual 8" (200mm) ducts from the dryers into the main discharge duct should be at a 45 degree angle in the direction of discharge air flow.

**NOTE:** Never install the individual 8" ducts at a right angle into the main discharge duct. The individual ducts from the dryers can enter at the sides or bottom of the main discharge duct. Figure 2 indicates the various round main duct diameter to use with the individual dryer ducts. The main duct can be rectangular or round, provided adequate air flow is maintained. For each individual dryer, the total exhausting (main discharge duct plus duct outlet from the dryer) should not exceed the equivalent of 20 feet (6m) and two elbows. The diameter of the main discharge duct at the last dryer must be maintained to exhaust end.

**NOTE:** A small diameter duct will restrict air flow; a large diameter duct will reduce air velocity – both contributing to lint build up. An inspection door should be provided for periodic clean-out of the main duct.

**NOTE:** STATIC BACK PRESSURE should be a maximum of 0.3 in. w.c (7.6 mm w.c) at the rear exhaust outlet of the dryer. If multiple dryers are connected to the common duct, ensure the back draft damper is installed properly.

**NOTE: The following illustration shows the various round main duct diameters to use with the individual dryer ducts. The main duct can be rectangular or round, provided adequate air flow is maintained. For each individual cylinder the total exhausting (main discharge duct plus duct outlet from the dryer) should not exceed the equivalent of 14 feet and two elbows. The diameter of the main discharge duct at the last dryer must be maintained to exhaust end.**

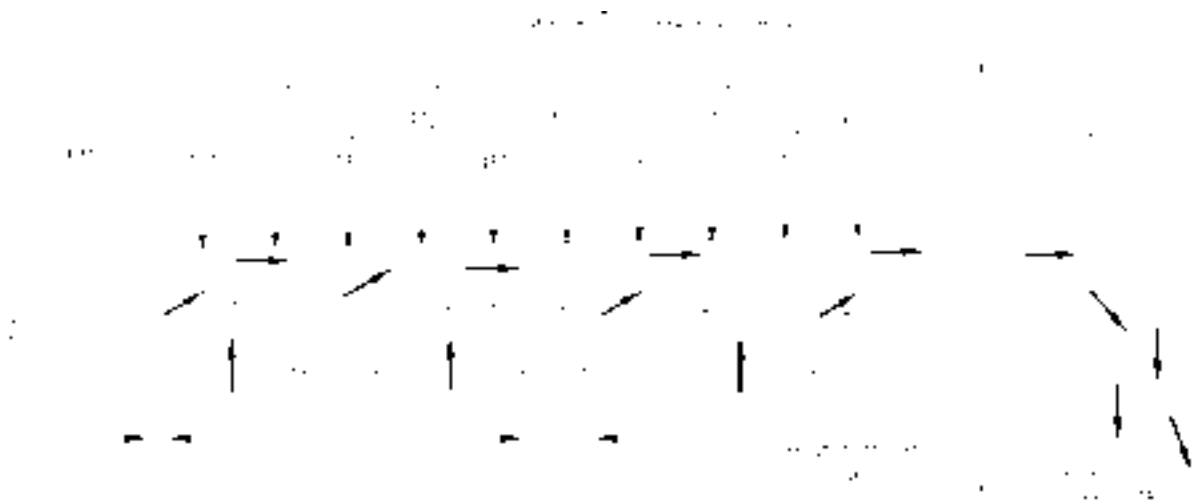

### DRYER IGNITION (SOLID STATE IGNITION).

The solid state ignition system lights the main burner gas by spark. The gas is ignited and burns only when the gas-valve relay (in the electronic controller) calls for heat. The procedure for first-time starting of a dryer is as follows:

- A. First, review and comply with the "WARNINGS ABOUT USE AND OPERATION" found on the inside front cover of this manual. Be sure the electrical power supply is connected correctly. The white (neutral) wire is to be connected to the N terminal while the black (line) wire to the L1 terminal of the terminal block in the rear control box. The dryer MUST be properly grounded.
- B. Make sure all gas supply lines are purged of air. Close the main gas shut-off valve and wait for five minutes before turning the valve back on.
- C. Turn on main electrical power switch. The dryer may be started by following the "OPERATING INSTRUCTIONS" found later in this manual.
- D. Natural gas and liquefied petroleum gas fired dryers both operate in the same manner. When gas-valve relay contacts are closed (indicating a demand for heat), the solid state ignition control will automatically supply energy to the redundant gas valve. Spark will continue until a flame is detected by the sensing probe, but not longer than 10 seconds. If the gas fails to ignite within 10 seconds, the gas will shut off for 15 seconds. The control will attempt to ignite two more times in a similar manner. If the gas fails to ignite after three tries, the gas valve closes and the system will "lock out". No further attempts at ignition will be performed automatically. It is then necessary to interrupt electrical power to the ignition system before making another attempt to light the burners. This can be done by opening the dryer door, allowing the dryer to come to a stop for 15 seconds, closing the door, and pushing the "Start" button. The dryer will then repeat the ignition trial cycle.

### DRYER SHUTDOWN

To render the dryer inoperative, turn off the main gas shut-off valve and disconnect electrical power to the dryer.

**IT IS RECOMMENDED THAT THE INSTALLER TEST THE DRYER FOR OPERATION AND INSTRUCT THE USER BEFORE LEAVING THE INSTALLATION.**



## Section 2: Dryer Operating Instructions

### OPERATING INSTRUCTIONS

1. Deposit coins or tokens to satisfy vend price display of idle dryer. Each deposit decreases vend price until display changes to show time purchased. LOW light illuminates.

2. Select drying cycle. Other cycle selections may be made now or later by pressing the appropriate key (button).

3. Close the loading door. Press "Start" button and the dryer will start. "Seconds" goes to 00. "Minutes" is rounded up and will count down each minute. The colon flashes on and off indicating the timer is counting down.

4. Clothes should be removed promptly after the cycle is completed to prevent excessive wrinkling.

Once started, the "timer" cannot be stopped. However, extra coins or tokens will be acknowledged by adding time to the display. The dryer may be stopped by opening the loading door, which interrupts the drive motor and gas burners. Close the loading door and push "Start" button to restart the dryer.

Cool-down time (owner programmable) is always part of the cycle time and is purchased by the customer. For example, if the cool-down time is 2 minutes, the last 2 minutes of the cycle will have no heat.

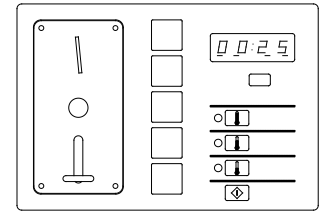

**VEND PRICE**

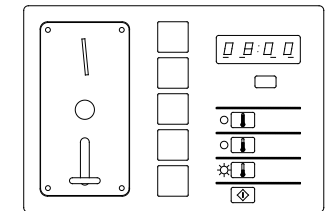

**MINUTES : SECONDS  
PURCHASED**

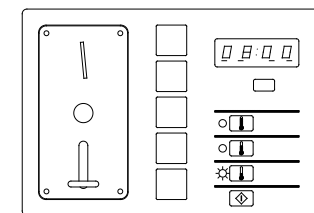

**START**



---

## Section 3:

### Dryer Programming Instructions

---

#### DESCRIPTION OF CONTROLS

Credit for coins or tokens inserted, dryer time, and temperature are controlled by an electronic controller.

The large digital display shows vend price of an idle dryer, time purchased after coins or tokens are deposited, temperature, and program information.

The three red indicator lights show the drying temperature selected. This selection may be made anytime.

The drying temperature will be displayed when the "Start"  $\diamond$  button and the temperature button for the selected temperature are pressed at the same time.

All programmed data is protected from power interruption of any length and the customer's individual cycle is protected for up to 3 seconds. This is done without batteries.

The 3 temperature buttons and the "Start"  $\diamond$  button become programming switches when the controller is in the program mode as described on page 13.

#### PROGRAMMING:

All operating parameters (vend price, temperatures, cool-down times, etc.) are adjustable. In addition, several displays of information are available from the controller (Money audits, hours run, dryer temperature).

The dryer is ready to run, from the factory, with the following pre-programmed data:

Temperature, HIGH $\downarrow$ :	175°F / 78°C
Temperature, MEDIUM $\downarrow$ :	150°F / 63°C
Temperature, LOW $\downarrow$ :	125°F / 48°C
Vend Price: 25¢	
Time for Left Coin:	3:20 (doesn't apply to single coin models)
Time for Right Coin:	8:00 (8 minutes for 25¢)
Time of Free Vend:	8:00 ("Free Dry" cycle is 8 minutes)
Cool-down Time, HIGH $\downarrow$ :	2:00 (Cool-down time in HIGH is 2 minutes)
Cool-down Time, MEDIUM $\downarrow$ :	2:00 (Same as above, except MEDIUM)
Cool-down Time, LOW $\downarrow$ :	2:00 (Same as above, except LOW)
Temperature Scale	F degrees
Decimal Point Display	ON
Seconds on Display	OFF

All of the above data can be easily changed by the owner. The changes are made by the 4 keys or buttons on the front of the control panel.

**PROGRAMMING INSTRUCTIONS:  
(To switch to program mode.)**

1. Unlock the upper service door and raise it until it can be held in place by the pivoting wire support.
2. Open the loading door and leave open.
3. Push the Program Button found between the service panel and the board. (Follow arrow on label)
4. Lower the upper service door to view the membrane switch keypad.
5. The control changes to PROGRAM mode. In PROGRAM mode, the membrane switch keypad becomes a 4-switch programming tool.
6. The ACTUAL NUMERICAL VALUES desired are keyed in as explained on page 14.

PROGRAM BUTTON  
UNDERNEATH HERE

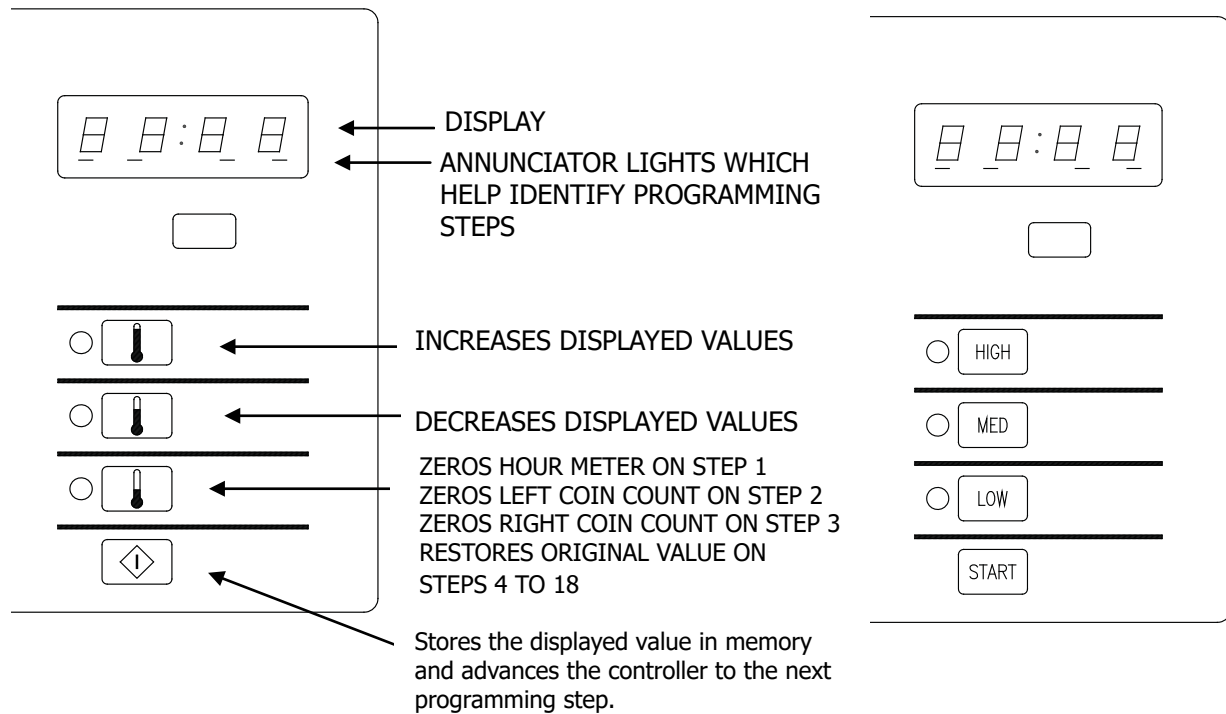
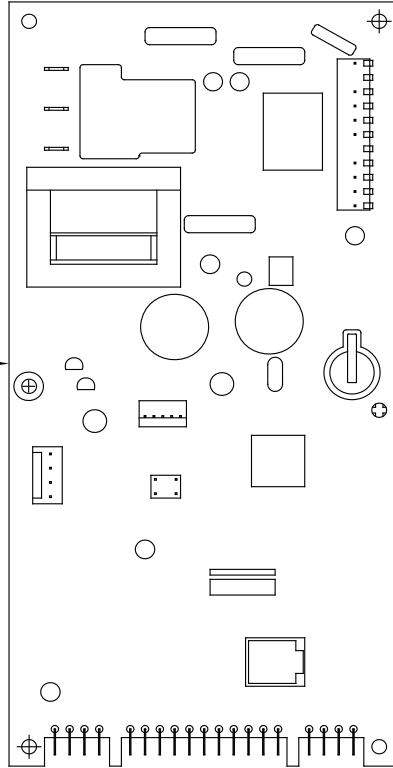

**IMPORTANT:** Please, remember to push "Start" to actually enter (store in memory) new data. If you merely change the display, memory hasn't yet been changed -- only "Start" will actually change the memory!

**ORDER OF PROGRAMMING STEPS:**

CYCLE LIGHTS	DISPLAY	PROGRAMMING STEP	DESCRIPTION	OPTIONS/RANGE OF LIMITS
HIGH, MED, LOW	---	HOURLY METER	Displays the hours of the "timer" operation.	May be reset to zero
HIGH, MED, LOW	---	LEFT MONEY AUDIT	Number of pulses from the left acceptor (dual coin models).	May be reset to zero.
HIGH, MED, LOW	---	RIGHT MONEY AUDIT	Number of pulses from the right acceptor (all models).	May be reset to zero.
HIGH	---	TEMPERATURE: HIGH	Median operating temperature-High (Regular).	150-190°F / 63-87°C
MEDIUM	---	TEMPERATURE: MEDIUM	Median operating temperature-Medium (Permanent Press).	120-170°F / 45-75°C
LOW	---	TEMPERATURE: LOW	Median operating temperature- Low (Delicate).	110-150°F / 39-63°C
	---	LEFT COIN VALUE	Value of coin or token deposited through the left acceptor (dual coin models) in 1¢ increments.	0 through 9999¢
	---	RIGHT COIN VALUE	Value of coin or token deposited through the right acceptor (all models) in 1¢ increments.	0 through 9999¢
	---	VEND PRICE	Money required to start the dryer in 1¢ increments.	0 through 9999¢ (0000 causes "Free Vend")
	---	TIME FOR LEFT COIN	Minutes and seconds awarded for one coin or token deposited through the left acceptor (dual coin models).	0 through 99:55 (minutes : seconds)
	---	TIME FOR RIGHT COIN	Minutes and seconds awarded for one coin or token deposited through the right acceptor (all models).	0 through 99:55 (minutes : seconds)
	---	TIME OF FREE VEND	Minutes and seconds of "Free" dry (If "Free" dry feature is used - see vend price above).	0 through 99:55 (minutes : seconds)
HIGH	---	COOL-DOWN TIME: HIGH	Minutes and seconds of cool-down: High cycle	0 through 10 minutes
MEDIUM	---	COOL-DOWN TIME: MEDIUM	Minutes and seconds of cool down: Medium cycle.	0 through 10 minutes
LOW	---	COOL-DOWN TIME: LOW	Minutes and seconds of cool-down: Low cycle.	0 through 10 minutes
		TEMPERATURE SCALE	Sets Temperature Display to °F or °C	F or C
		DISPLAY: DECIMAL POINT	Displays decimal point in prices.	OFF or ON
		DISPLAY: SECONDS	Displays time remaining in minutes:00 (OFF) or in minutes:seconds (ON).	OFF or ON



# Section 4:

## Dryer Service Procedures

### Trouble Shooting and Schematics

## Service Procedures

### Pressure Testing

The dryer and its individual shutoff valve must be disconnected from the gas supply piping system during any pressure testing of that system at test pressures in excess of 1/2 psig (14" water column). The dryer must be isolated from the gas supply piping system by closing its individual manual shutoff valve during any pressure testing of the gas supply piping system at test pressures equal to or less than 1/2 psig.

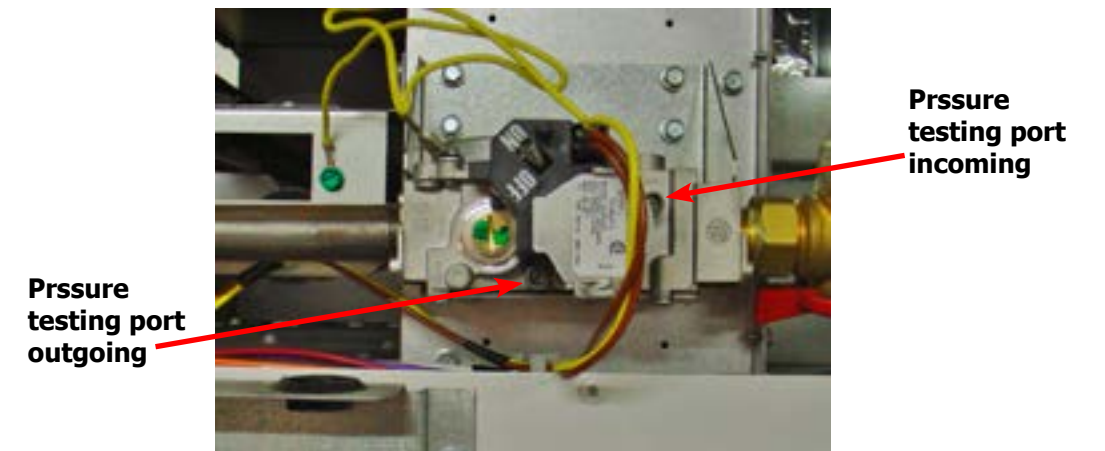

### Clothes Door Removal

Step 1: Open door and remove inner hinge plate cover by removing the two Phillips screws.  
Step 2: The clothes door may be removed from the hinge bracket by unscrewing and removing the top 3/16 allen head pivot screw located at the door upper hinge point, you will also need to use a 1/4 allen wrench in the lower fastener.  
Step 3: Next lean the door out of the top of the hinge bracket and lift the door from the bottom hinge pin.

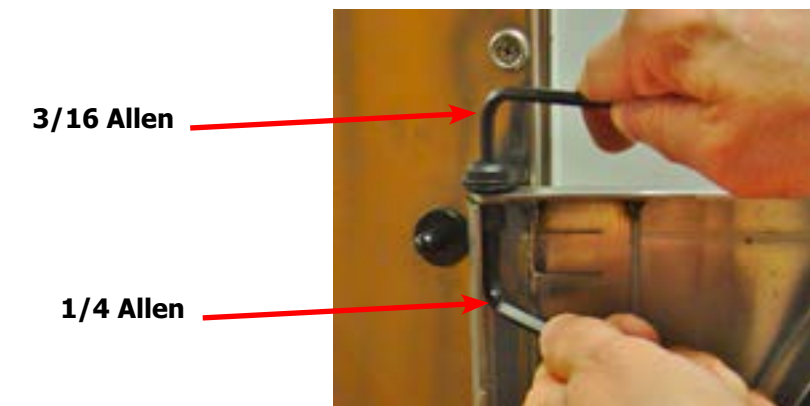

### Front Panel Removal

**Step 1:** Remove the loading door from the panel (optional, the front panel may be removed without taking off the door).  
**Step 2:** Open upper service door, and remove lint door.  
**Step 3:** Then remove the two left side phillips screws w/beveled washers and the two right side phillips w/beveled washers screws. Next disconnect door switch wires from back of loading door switch.

## Door Switch Removal & Installation

**Step 1:** Remove front panel (see front panel removal).

**Step 2:** Next disconnect door switch wires from back of loading door switch. Remove door switch by depressing the two tabs on switch and remove from the front of the panel.

Note: For the 80lb, you will have to remove the door switch cover first by removing the two 3/8" nuts.

**Step 3:** reassemble in reverse order.

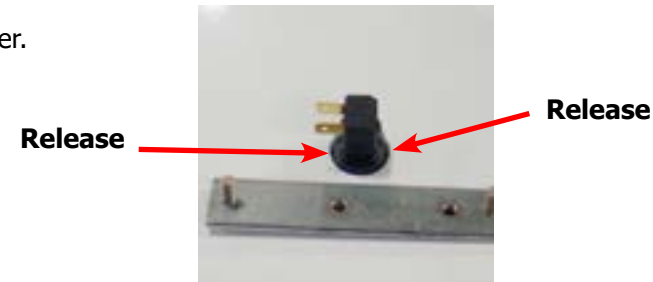

## Door Switch Operation & Testing

The normally open door switch must be closed (0 ohms resistance) for the motor and heat circuits to operate. When the door is opened, the door switch opens the 24 volt control circuit.

## Clothes Door Latch Adjustment

**Step 1:** Loosen the lock nut on the latching stud. It is located directly behind the door handle.

**Step 2:** Open the loading door.

**Step 3:** Screw the door catch stud in or out as necessary and then retighten the lock nut.



## Installation of Clothes Door Window & Gasket

**Step 1:** Remove the loading door.

**Step 2:** Place the clothes door, with its face down, on a solid surface.

**Note:** Pre-warming the gasket under a heat lamp makes the installation much easier.

**Step 3:** Put the door glass gasket on the loading door with the ridges in the wide side up. Locate the seam at the door latching stud.

**Note:** The gasket has one narrow opening on one side and a wide opening on the other. The narrow side mounts to the door. The wide side holds the glass. The wide side has ridges on one interior lip. This ridged side should go up with the door lying face down.

**Step 4:** Coat the inside and outside of the gasket with rubber lubricant or liquid soap.

**Step 5:** Slide the glass into the middle of the gasket with half of the glass above the door and half below the door.

**Step 6:** While pressing on the glass, use a modified screwdriver (grind the end off so that it is round and put a slight bend in it) and run it around half of the glass.

**Step 7:** With half of the glass installed, turn the door over and repeat step 6.

**Step 8:** Insert the modified screwdriver at the 6 o'clock position and pry the glass up enough to install the door glass support spacer (small diameter rubber tube).



Glass inserted half way

## High Limit Thermostat Locations & Functions Burner Housing

This hi-limit is located on the rear of the burner housing.

**STEP 1:** The thermostat opens the circuit to the main burners in the event of malfunction in the gas control area or temperature control. This thermostat will open quickly if there is a significant loss of air flow over the burner area.

**STEP 2:** It is held in place by two screws. There are spacers between the thermostat and bracket which must be used to give proper operation.

**Removal :** To remove the hi-limit thermostat on the side of the burner housing, remove the terminal of each wires attached to the thermostat. Lastly, remove the mounting screws holding the thermostat to the burner housing.

High Limit Thermostat



## Manual Resettable Over Temperature Safety Thermostat

The second hi-limit thermostat is located outside the rear exhaust opening mounted on the left side of the exhaust duct at the rear outlet height.

**Step 1:** The manually resettable thermostat limits the operating temperature a dryer can reach should some abnormal situation occur.

**Step 2:** Should the thermostat be tripped, the dryer will cease to heat until the thermostat is reset. Once the dryer cools, the thermostat may be reset by pushing the button in.

**REMOVAL:** To remove the manual resettable over temperature safety thermostat next to the exhaust duct. First, remove the terminals of each wire attached to the thermostat. Next, remove mounting screws holding the thermostat to the dryer cabinet.

Overtemp Thermostat

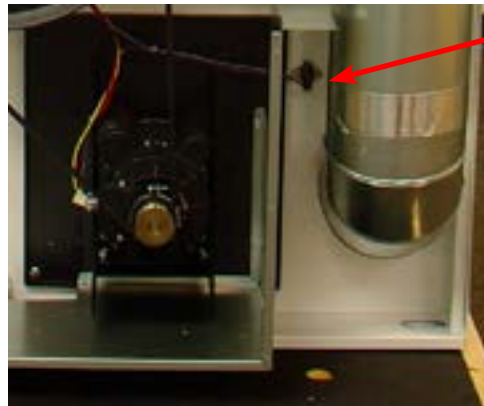

## Pressure Regulator Adjustment

Use the following procedure whenever it is necessary to check the pressure regulator setting. NOTE: Any adjustment of the pressure regulator must be made with a manometer attached at the plug in the main burner manifold.

**Step 1:** Shut off the gas supply to the dryer.

**Step 2:** Remove the 1/8" pipe plug from the end of the main burner manifold.

**Step 3:** Attach a manometer to the manifold end.

**Step 4:** Remove the pressure regulator cover screw on the gas valve.

**Step 5:** Open the shut-off valve, and operate the dryer.

**Step 6:** Adjust the pressure for a manometer reading of 3.5" water column gas pressure. (11.0" for L.P.)

**NOTE:** The main burners must be operating when adjusting the pressure regulator.

**Step 7:** Shut off the gas supply to the dryer. Remove the manometer and install the 1/8" pipe plug in the manifold.

**Step 8:** Open the shut off valve, start the dryer and check for gas leaks while the burners are ignited.

**NOTE:** Always remove power from the machine before changing drive belts or working with the drive and fan system.

1/8" pipe plug



Adjustment Screw Under Plug

## Final Drive Belt Replacement

To replace the final drive belt turn the cylinder slowly by hand and work the belt off of the large pulley.

## Motor Drive Belt Replacement

To replace the motor drive belt the final drive belt should be removed as above. Next turn the intermediate drive pulley and work the belt off of it similarly to the above belt.

## Blower Motor Removal

**Step 1:** Remove Rear upper and lower Belt pulley guards.

**Step 2:** Remove rear electrical box cover.

**Step 3:** Remove left and bottom side guard.

**Step 4:** Remove belts.

**Step 5:** Disconnect wires from the over temperature switch and cut the two wire ties securing gray wire to motor harness.

**Step 6:** Remove the wire clamp holding motor wire loom to cross member by removing the 5/16 screw.

**Step 7:** Remove the two beaded ties securing harness behind pulleys.

**Step 8:** Remove last wire tie connecting gray wire to motor harness.

**Step 9:** Next, inside the rear control box disconnect red wire, 1/4 inch quick connect inside splice connector.

**Step 10:** Remove black and yellow wires from R1 relay.

**Step 11:** Remove motor harness from control box.

**Step 12:** Next remove blower motor, back plate, and impeller from machine by removing the four 9/16 nuts.

Reassemble in reverse order.

## Blower Impeller Removal

Remove Blower motor assembly. Take notice of the location of the impeller location on the shaft. Remove the two set screws that hold the motor to the shaft.

## Airflow switch removal and adjustment

The air switch assembly is part of the ignition safety circuit and insures that the burner doesn't operate unless there is airflow. If this doesn't happen, ignition will not occur. The air switch assembly is located on the back of the Dryer.

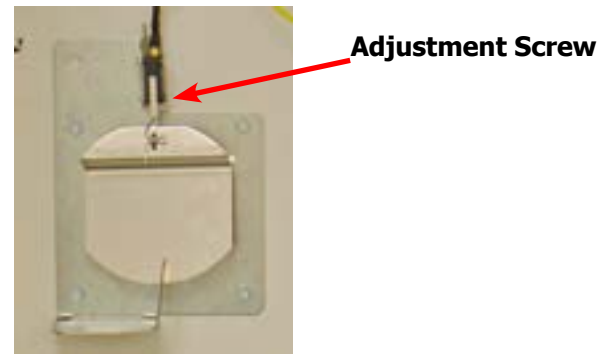

## Electronic Ignition Module

This machine uses an electronic spark ignition system to directly light the burners.

- Step 1:** The electronic ignition module (gray box) is located inside the rear control box.
- Step 2:** The red wire from the transformer provides 24 VAC through the 1.5 amp fuse and into the module to operate the entire direct ignition system.
- Step 3:** The black colored hi-voltage wire (spark plug type) plugs onto the post connector on the module, and the multi-wire plug fits into the side of the module.

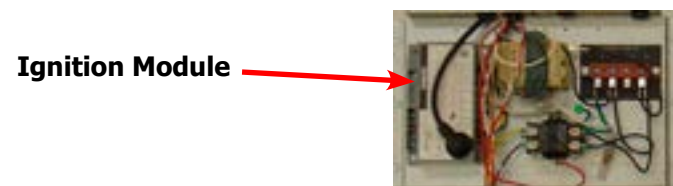

## Spark Electrode Assembly-Removal

- Step 1:** Disconnect wires to electrodes.
- Step 2:** Remove two screws to detach electrode assembly.

**NOTE:** Proper grounding of the ignition system (yellow wires) is very critical for proper ignition sequence

If there is no spark or intermittent spark, check black hi-voltage lead wire for damage or cracks in insulation. This lead wire must not be taped or connected to any metal edges along its length to prevent pinching and arcing. Also, do not bundle this wire with other wires.

Note : Spark gap and electrode location are important. If the electrode is damaged or mounting is changed the spark gap may not be correct for ignition to occur. Check for cracks in the ceramic insulator. Replace electrode assembly if necessary. Also check for carbon or foreign material on the electrodes and clean if necessary.

## Gas Valve & Manifold Removal

- Step 1:** Disconnect union at gas valve and disconnect wires from gas valve operator coils.
- Step 2:** Remove Gas Valve mounting bracket by removing the 4 5/16 screws.

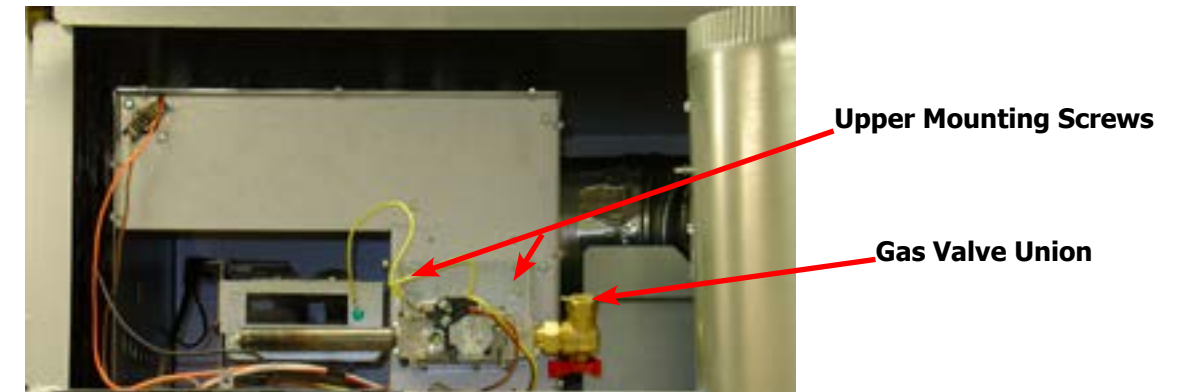

## Main Burner Orifice Removal

- Step 1:** Remove manifold and gas valve assembly as above.
- Step 2:** Using an open end wrench, remove orifices from manifold.

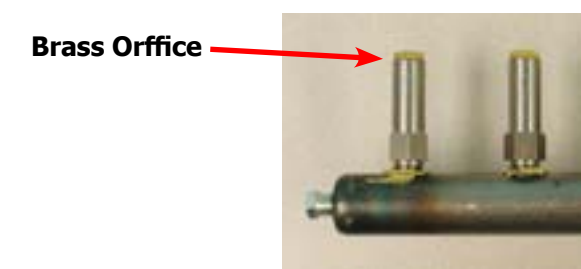

## Main Burner Removal

Remove manifold & gas valve assembly as previously discussed. Remove the four 9/16 screws securing the front of the burner to the support bracket. The burners may now be removed.

## Cylinder Pulley Removal

30Lb  
Remove bolt and washers holding pulley to cylinder shaft. Reinsert bolt then using two or three jaw puller Pull pulley straight off of shaft.  
50lb & 80Lb  
Remove bolt and washers holding pulley to cylinder shaft. Reinsert bolt then using "T" puller w/ 3/8-16UNC bolts, Pull pulley straight off of shaft

### Intermediate Pulley Removal

30Lb & 50Lb

The intermediate pulley can be removed by removing the snap ring holding the pulley to the tension arm.

**Note:** Cylinder pulley must be removed first.

80Lb

The intermediate pulley can be removed by removing the nut holding the pulley to the tension arm.

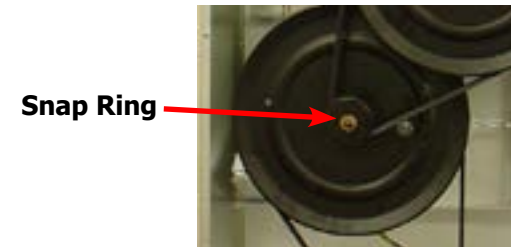

### Tension Arm Assembly Removal

The tension arm assembly may be removed by removing the snap ring that holds it to the tension arm support assembly pin. If it is necessary the arm assembly is replaced as a complete unit.



### Tension Arm Support Assembly Adjustment

The tension arm support assembly may be adjusted for alignment of the intermediate pulley and also to align the belts. The three outer nuts allow the alignment of the pin to be adjusted by pivoting the assembly on the center bolt. The center bolt can be screwed in to allow bringing the complete assembly farther back if necessary for belt alignment.

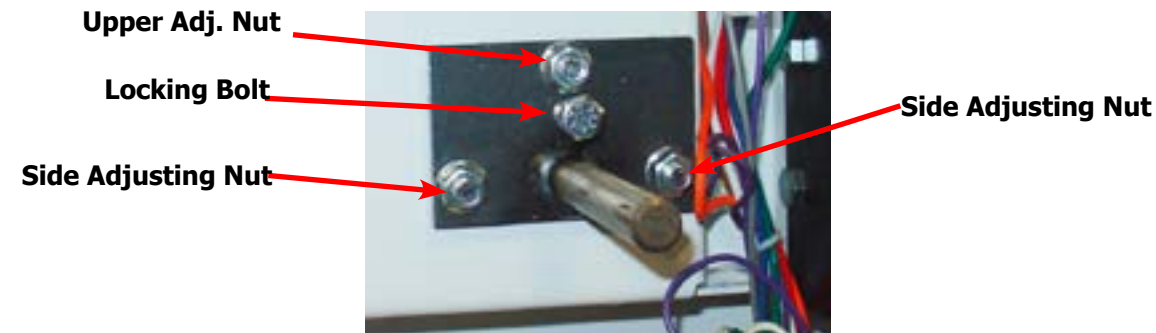

### Cylinder Removal

- Step 1:** Remove the front panel in front of the cylinder.
- Step 2:** Remove drive belt, bolt, washers, and pulley.
- Step 3:** Pull the cylinder from the front of the machine.

### Adjustment of Cylinder Assembly

- Step 1:** Loosen the two top adjusting bolts and two bottom adjusting nuts and lock nuts holding the bearing housing to the drive plate.
- Step 2:** Loosen the four mounting bolts on the side channels.
- Step 3:** Open the clothes door and insert a 1/2" thick shim at the 3 and 9 o'clock positions and a 1/4" thick shim at the 6 o'clock position.
- Step 4:** Tighten the two bottom adjusting nuts and tighten locking nuts.
- Step 5:** Tighten the bottom right mounting bolt, then the top left mounting bolt. Tighten the remaining two bolts. (Shim where and if necessary.)
- Step 6:** Tighten the two top adjusting bolts.
- Step 7:** Remove all the shims from between the front panel flange and cylinder (3,6,9 and 12 o'clock).
- Step 8:** Spin the cylinder to check for rubbing baffles, pressing down hard while rotating. If rubbing is detected, repeat procedure paying particular attention to placement of shims between bearing housing and side channels.

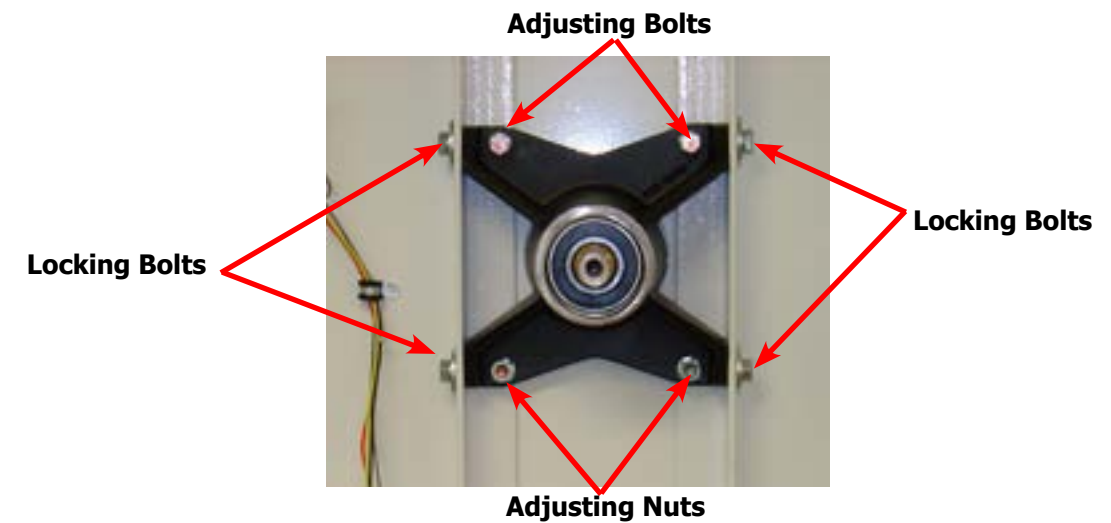

### Bearing Housing Removal

After removing cylinder as previously outlined, simply unbolt the four outside bolts and the two lower nuts and remove the bearing housing.

## Spark Electrode Assembly-Function

**Step 1:** The spark electrode and sensing electrodes are located directly at the side of the burner housing.

**Step 2:** The electrode with the black hi-voltage wire conducts the spark to the center grounding probe, directly over the burner.

**Step 3:** The electrode with the black sensing wire detects ignition and monitors flame by signaling the module.

**NOTE:** Proper grounding of the ignition system (yellow wires) is very critical for proper ignition sequence.

## Ignition System-Function & Sequence

During normal dryer operation, the following occurs:

**1.** The dryer electronic control calls for heat.

**2.** From the 24VAC control transformer, voltage for the heat circuit is applied to the control through the door switch. If the control detects that the heat should be on, a circuit is closed providing power through the over-temp thermostat, the air damper switch, the high limit switch and the motor centrifugal switch to the Ignition Module. Once the 24VAC reaches the ignition module on the red wire, sparking occurs at the ignition electrode and 24VAC is applied to open the Gas Valve.

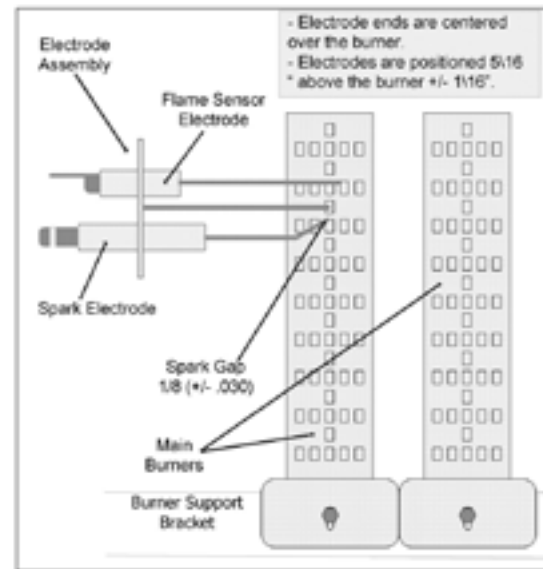

**3.** Once the flame is established, the sensing electrode detects the presence of flame and the sparking stops.

**4.** If for any reason the flame is not established in a period of 10 seconds, the electronic control will try this sequence for 3 tries. Normally the 10 seconds "Trial For Ignition" period is ample to establish and prove flame.

**5.** If the flame is shutdown or blown out during operation, the ignitor will immediately go into "Trial. For Ignition" again for 10 seconds.

**6.** However, at the end of 3 separate retries of 10 seconds "Trial for Ignition", the flame is not established, the ignition system goes into "Safety Lock-Out" and will not reactivate the "Trial for Ignition" until there is a current interruption for a period of 15 seconds. This interruption can be provided by opening the dryer loading door and allowing the machine to come to a complete stop for 15 seconds.

## Dryer Trouble Shooting

Symptom	Probable Cause	Suggested Remedy
Tumbler does not turn	Drive belts	Check both drive belts. Replace if failed.
	Tumbler does not turn	Check capacitor and motor. Replace if failed
	Door switch	Check door switch contacts and adjustment. Adjust or replace door switch.
	Timer Tumbler does not turn	Check to see if heat timer is turned on
Tumbler turns but no spark at burner	Glass fuse	Check small glass control fuse in back of dryer. Replace if failed.
	Thermostat	Check if voltage is passing through the two wires attached to the temperature thermostat
	Ignition	Check for 24VAC output from transformer.
	Transformer	Replace if have 120V between black & white and no 24V between red and yellow.
	Over temperature	Check to see if manually resettable thermostat. Thermostat is kicked out. Reset by pushing red reset button.
	Ignition control	Check for 24VAC coming into the control on the at burner red wire. If voltage, then check for 24VAC out on the brown wire. Also check for spark at the ignitor. If no 24VAC output or no spark to the ignitor, replace ignition control.
	Air Flow Switch	Check air flow switch to be sure it closes when dryer is running. If not, adjust or replace switch.
	Hi-limit	Check for continuity. Should be 0 ohms resistance when cold. If not, replace thermostat.
	Gas supply	No gas can cause system lockout

## Dryer Trouble Shooting

Symptom	Probable Cause	Suggested Remedy
Tumbler turns, ignition sparks, no flame	Gas supply	Make sure gas supply is working.
	Gas pressure	Make manometer check of gas pressure. Adjust if necessary.
	Spark Electrode Sensor	Check for damage to electrode or mounting. Replace if necessary.
	Gas valve	Check coil continuity, replace valve if failed.
	Ignition Control	Check for 24VAC to gas valve coils. If no voltage replace ignition control.
Burner Lights, but goes on and off	Electrodes	Check low voltage harness for possible wire break or cuts to allow no signal back to ignition control
Slow drying	Temperature Setting	Check thermostat for correct high temperature setting. Adjust if necessary.
	Air flow restrictions necessary	<ol style="list-style-type: none"> <li>1. Check lint screen and clean if necessary.</li> <li>2. Check exhaust for correct length and clean if necessary.</li> <li>3. Check exhaust damper to insure that it opens when dryer is running and closes when dryer is not in use.</li> <li>4. Check makeup air to insure that it is adequate. Increase makeup air if necessary.</li> <li>5. Check static Back pressure no more than .3</li> </ol>
Manual overtemp Tripping Frequently	Recirculating chamber Lint Accumulation	Remove manual overtemp thermostat and inspect in chamber for excessive lint build up. Access also gained to this chamber by removing recirculation duct mounted at bottom of chamber, or the panel inside burner chamber between burners and rear back panel
	Exhaust ducting Excessive lint buildup	Remove exhaust duct at rear of dryer and inspect for excessive lint build up in complete duct from dryer to where duct exits building.
	Clean lint from top heat air chamber above tumbler	Remove front panel completely. Be careful of any wiring attached. Remove heated air chamber cover and clean above tumbler back to burner housing.

## DRYER FAULT CODES

FAULT #	FAULT DESCRIPTION	ACTION
F1	Shorted thermostat sensor.	Dryer stops and "F1" flashes on the 4-digit display. When short circuit on sensor input is removed, "LOAD" appears on the 4-digit display and the remaining dry time is reset.
F2	Open thermostat sensor.	Dryer stops and "F2" flashes on the 4-digit display. When a good sensor is connected to sensor input, "LOAD" appears on the 4-digit display and the remaining dry time is reset.
F3	EEPROM corrupted	Dryer will not start and "F3" appears on the 4-digit display. The power to the dryer must be cycled to reset the controller. Fault should only occur when starting a dry cycle.





## Kits, Assemblies, & Common Parts

Coin Acceptor Components	Part Number
Mechanical Coin Acceptor	9021-001-010
Coin Drop Screws	9545-053-002
Retainer, Coin Acceptor	9486-149-001
Loading Door Components	Part Number
Door Handle	9244-093-001
Door Close Switch	9539-492-001
Electrical Components	Part Number
Relay, Motor Run (24VAC)	5192-299-002
Transformer, Control	8711-007-002
Controls 120VAC	9471-011-003
Heating Circuit Components	Part Number
Ignition Control Module	9857-182-001
Ignition Electrode Assembly	9875-002-003
Thermostat, Hi-Limit	9576-203-002
Thermostat, Overtemp	9576-207-006
Airflow Switch	9539-461-009
Cabinet Components	Part Number
Cleanout Duct Assembly 8"	9973-034-001



DCBD30KC\_-10  
DCBD50KC\_-10  
DCBD80KC\_-10

## Section 5: Dryer Parts Data

## Dryer Cabinet Group

Key	Description	T-30	T-50	T80	
1	Loading Door Complete SS/ Brushed SS/Blk	9960-306-001	9960-305-001	9960-305-001	1
1	Loading Door Complete Wht/ Brushed SS/Blk	9960-306-003	9960-305-003	9960-305-003	1
2	Door Assy, Loading (Ring only) Brushed SS	9960-255-008	9960-284-002	9960-284-002	1
3	Plate Assy, Hinge (SS)	9982-374-001	9982-368-001	9982-368-001	1
3	Plate Assy, Hinge (Wht)	9982-374-003	9982-368-003	9982-368-003	1
*	Cover-Hinge Back, Black	9074-341-002	9074-340-002	9074-340-002	1
*	Screw-10Bx3/8, Black	9545-008-010	9545-008-010	9545-008-010	2
*	Screw Hinge to Door	9545-012-015	9545-012-015	9545-012-015	4
*	Nut, Hinge to Door	8640-413-002	8640-413-002	8640-413-002	4
4	Glass, Door	9212-002-003	9212-002-004	9212-002-004	1
5	Gasket, Door Glass (Black)	9206-413-001	9206-413-002	9206-413-002	1
*	Support Door Glass	9548-117-000	9548-117-000	9548-117-000	2
6	Gasket, Door Outer Rim (Black)	9206-420-003	9206-420-005	9206-420-005	1
7	Handle, Loading Door	9244-082-001	9244-082-001	9244-082-001	1
*	Screw, Handle	9545-018-017	9545-018-017	9545-018-017	2
8	Stud Door Catch	9531-033-001	9531-033-002	9531-033-002	1
9	Nut-Hex, #10-32	8640-413-001	8640-413-001	8640-413-001	1
10	Nut, Acorn	8640-413-003	8640-413-003	8640-413-003	1
*	Catch, Loading Door	9086-015-002	9086-015-002	9086-015-002	2
*	Rivit	8638-190-009	8638-190-009	8638-190-009	4
11	Strap, Hinge (Black)	9966-015-002	9966-014-002	9966-014-002	1
*	Plate Assy-Backup, Hinge	9982-371-001	9982-356-001		1
*	Plate Assy-Backup, Hinge			9982-369-001	1
*	Reinforcement-Front panel			9817-003-001	1
12	Screw-Phillips, 10-32x1/2 Chrome	9545-012-003	9545-012-003	9545-012-003	4
*	Screw-Phillips-Counter sink, 10- 32x1/2 Chrome	NA	9545-012-028	9545-012-028	4
13	Screw-Special, Hinge to Door	9545-052-001	9545-052-001	9545-052-001	1
*	Nut-Allen, 1/4-20	8640-439-001	8640-439-001	8640-439-001	1
14	Washer-Fiber/Plastic	8641-436-003	8641-436-003	8641-436-003	1
15	Front Panel Assy (SS)	9454-869-001	9454-865-001	9454-867-001	1
15	Front Panel Assy (Wht)	9454-869-003	9454-865-003	9454-867-003	1
16	Screw-Phillips, 10Bx1 3/4	9545-008-014	9545-008-014	9545-008-014	4
17	Washer-Finish	8641-585-001	8641-585-001	8641-585-001	4
*	Nut-Spring	8640-399-001	8640-399-001	8640-399-001	4
*	Insulation-Front Panel, Top Half	9277-062-001	9277-057-001	9277-058-001	1
*	Insulation-Front Panel, Bottom Half	9277-062-002	9277-057-001	9278-058-002	1
*	Switch-Door Closed	9539-492-001	9539-492-001	9539-492-001	1
*	Wire-Assy, Blk	8220-063-026	8220-063-026	8220-063-026	1
*	Wire-Assy-Blu	8220-063-009	8220-063-009	8220-063-009	1
20	Coin Box Blue	9807-099-002	9807-099-002	9807-099-002	1
20	Coin Box Black	9807-099-004	9807-099-004	9807-099-004	1
*	Cabinet Touch Up Paint (White)	9472-001-013	9472-001-013	9472-001-013	1

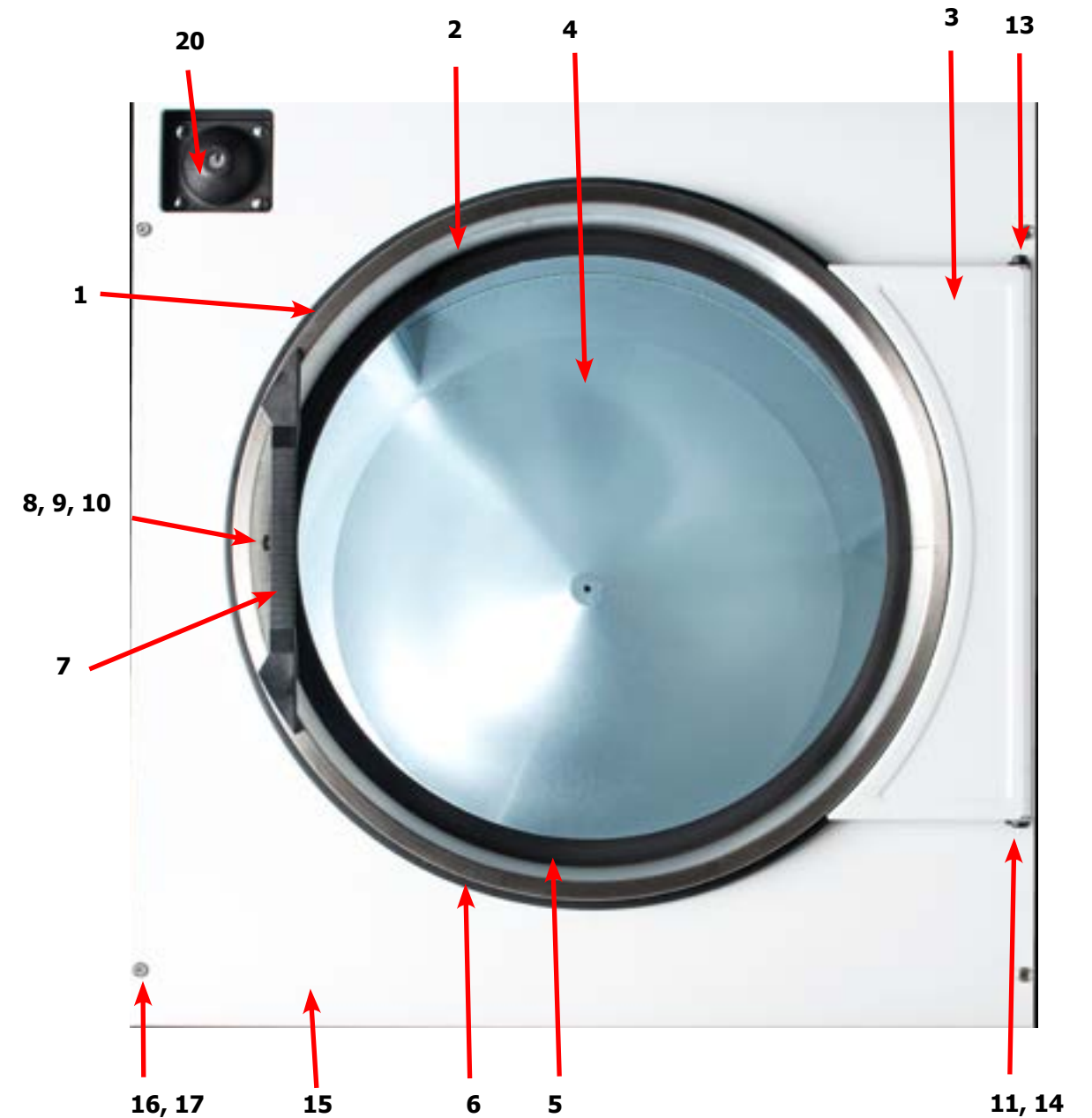

## Dryer Cabinet Group Continued

Key	Description	T-30	T-50	T80	QTY
1	Nameplate - Dexter Dryer Blue	9412-083-001	9412-083-001	9412-083-001	1
1	Nameplate - Dexter Dryer Black	9412-174-001	9412-174-001	9412-174-001	1
2	Additional Nameplate (Black only)	9412-175-001	9412-178-001	9412-177-001	1
3	Door Assy-Upper, Coin (SS)	9960-287-001	9960-289-001	9960-291-001	1
3	Door Assy-Upper, Coin (Wht)	9960-287-003	9960-289-003	9960-291-003	1
*	Bracket-Hinge	9029-224-001	9029-224-001	9029-224-001	2
*	Rivit- 3/16, Hinge to Door	9491-009-001	9491-009-001	9491-009-001	2
*	Rivit- 3/16, Hinge to Cabinet	9491-009-001	9491-009-001	9491-009-001	AR
4	Trim-Upper Service Door, Black	9578-098-002	9578-094-002	9578-096-002	1
5	Screw-Phillips, 10Bx3/8, Black	9545-008-010	9545-008-010	9545-008-010	4
6	Label Instructions Blue	8502-746-002	8502-746-002	8502-746-002	1
6	Label Instructions Black	8502-746-001	8502-746-001	8502-746-001	1
7	Label Warning	8502-748-016	8502-748-016	8502-748-016	1
8	Lock Assy and Key Upper	8650-012-003	8650-012-003	8650-012-003	1
9	Cam Lock Upper Door	9095-047-001	9095-047-001	9095-047-001	1
*	Key, FJWCC	6292-006-006	6292-006-006	6292-006-006	1
10	Membrane Switch Blue	9801-102-002	9801-102-002	9801-102-002	1
10	Membrane Switch Black	9801-102-001	9801-102-001	9801-102-001	1
11	PCB-Controler	9471-011-003	9471-011-003	9471-011-003	1
*	Spacer-#6 x 1/2	9538-157-016	9538-157-016	9538-157-016	3
*	Spacer #6 x 7/8	9538-157-017	9538-157-017	9538-157-017	2
*	Nut- #6-32	8640-411-003	8640-411-003	8640-411-003	4
	Nut- #6-32 (Grounding nut)	8640-411-001	8640-411-001	8640-411-001	1
12	Wire Assy-GRN, 24"	8220-137-001	8220-137-001	8220-137-001	1
13	Support-Upper Service Door	9548-288-001	9548-288-002	9548-288-002	1
14	Clamp-Tube	9079-121-002	9079-121-002	9079-121-002	2
*	Nut, #6-32	8640-411-003	8640-411-003	8640-411-003	2
15	Clamp-Cable, 1/2"	8654-125-006	8654-125-006	8654-125-006	1
*	Nut, #6-32	8640-411-003	8640-411-003	8640-411-003	1
16	Insulation	9277-041-016	9277-041-016	9277-041-016	1
17	Coin Acceptor	9021-001-010	9021-001-010	9021-001-010	1
18	Retainer-Coin Accepctor	9486-149-001	9486-149-001	9486-149-001	2
19	Screws-Torq, 4Bx5/8 ss	9545-053-002	9545-053-002	9545-053-002	4
*	Coin Switch, Kit	9732-126-001	9732-126-001	9732-126-001	1
*	Coin Shute	9940-016-001	9940-016-001	9940-016-001	1
*	Screw	9545-008-001	9545-008-001	9545-008-001	1
*	Nut, Elastic Stop	8640-413-004	8640-413-004	8640-413-004	*

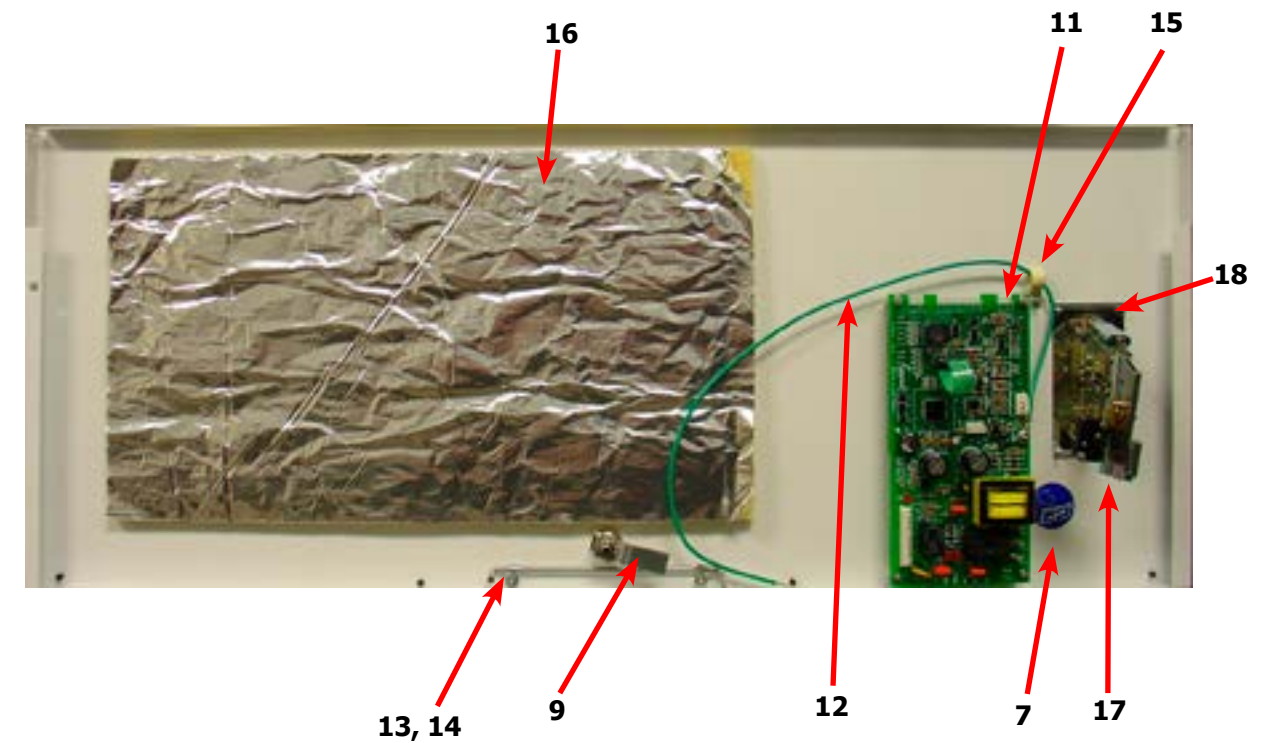
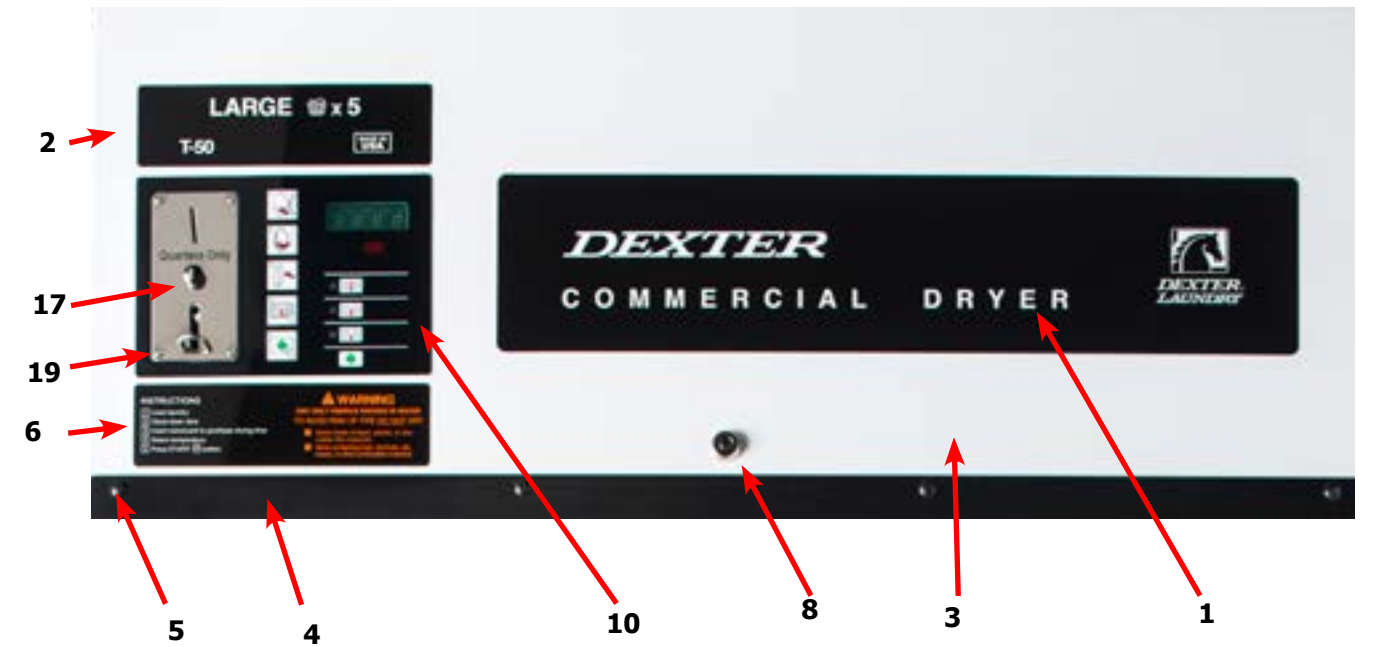

## Dryer Cabinet Group Continued

Key	Description	T-30	T-50	T80	QTY
1	Door-Lower Service, Coin, SS	9108-130-001	9108-122-001	9108-126-001	1
1	Door-Lower Service, Coin, Wht	9108-130-003	9108-122-003	9108-126-003	1
2	Lock Assy and Key Lower Door	8650-012-004	8650-012-004	8650-012-004	1
*	Cam Lock Lower Door	9095-048-001	9095-048-001	9095-048-001	1
*	Washer-Flat	8641-581-041	8641-581-041	8641-581-041	2
3	Handle-Door, Lower Service OPL	9244-084-002	9244-087-002	9244-088-002	1
4	Screw-Phillips, 10Bx3/8, Black	9545-008-010	9545-008-010	9545-008-010	5
5	Trim-Lower Kick, Black	9578-099-002	9578-095-002	9578-097-002	1
6	Screw-Phillips, 10Bx3/8, Black	9545-008-010	9545-008-010	9545-008-010	4
7	Screen Assy, Lint	9822-026-002	9822-026-001	9822-031-002	1
8	Switch-Door Closure (Round)	9539-492-001	9539-492-001	9539-492-001	1
*	Kit, Optional Replacement for Round Switch 9539-492-001	9732-351-001	9732-351-001	9732-351-001	1
9	Hinge-Door, Lower	9243-081-001	9243-082-001	9243-082-001	1
10	Screw-5/16, 10ABx3/8	9545-008-024	9545-008-024	9545-008-024	5
11	Bracket-Door Switch	9029-226-001	9029-226-001	9029-226-001	1
*	Rivit, 1/8 Low Profile	9491-009-004	9491-009-004	9491-009-004	2
12	Bracket-Chain	9029-223-001	9029-223-001	9029-223-001	2
*	Rivit, 1/8 Low Profile	9491-009-004	9491-009-004	9491-009-004	8
13	Hook, "S" Type	9248-022-002	9248-022-002	9248-022-002	4
14	Chain	9099-012-006	9099-012-006	9099-012-006	2
*	Leg, Leveling 1/2"	8544-006-001	8544-006-001	8544-006-001	4

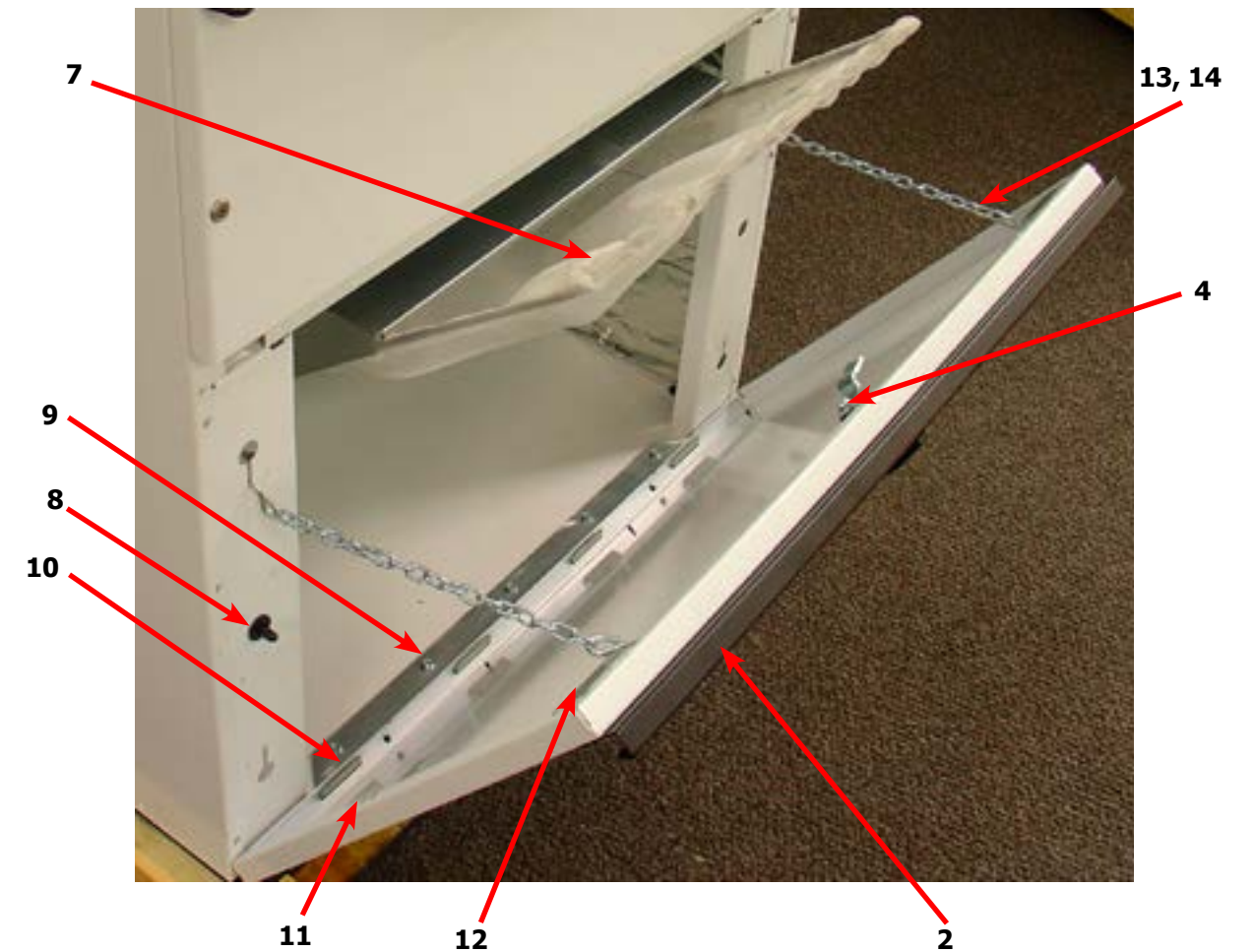
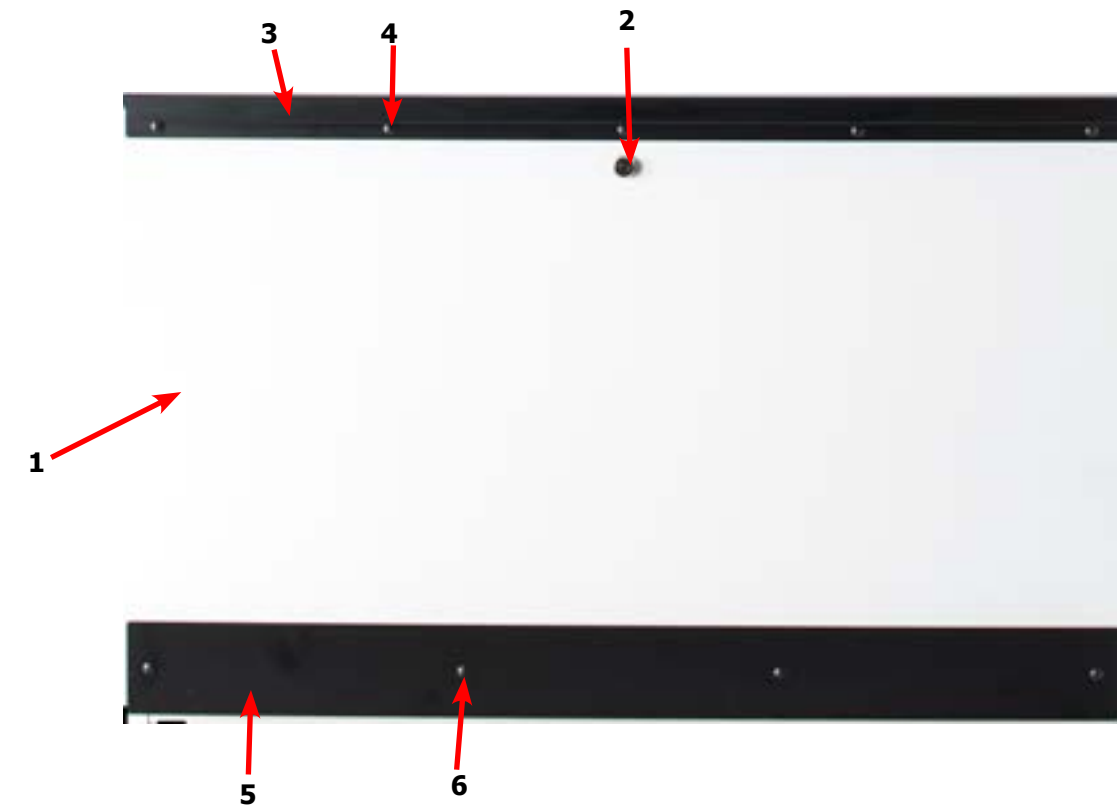

## Dryer Cabinet Group Continued

Key	Description	T-30	T-50	T80	QTY
1	Insulation, Upper service Door	9277-041-006	9277-041-016	9277-041-016	1
2	Insulation, RH Burnner	9277-041-019	9277-041-019	9277-041-023	1
3	Insulation Tumbler Area, above Baffle	9277-041-020	9277-051-003	9277-041-021	2
3	Insulation Tumbler Area, above Baffle		9277-051-003	9277-041-021	2
4	Insulation Tumbler Area, below baffle	9277-041-020	9277-051-003	9277-051-004	2
4	Insulation Tumbler Area, below baffle		9277-051-003	9277-051-004	2
5	Insulation Lint Compartment	9277-041-021	9241-041-024	9277-041-025	2
*	Screen Assy, Lint	9822-026-002	9822-026-001	9822-031-002	1
6	Switch-Door Closure	9539-492-001	9539-492-001	9539-492-001	1
7	Hinge-Door, Lower	9243-081-001	9243-082-001	9243-082-001	1
8	Screw-5/16, 10ABx3/8	9545-008-024	9545-008-024	9545-008-024	AR
9	Lint Hood-Back	9240-038-001	9240-041-001	9240-044-001	1
10	Nut Wizlock, 8-32	8640-412-004	8640-412-004	8640-412-004	6
11	Lint hood, LH	9240-040-001	9240-043-001	9240-046-001	1
12	Lint hood, RH	9240-040-002	9240-043-002	9240-046-002	1
13	Lint hood, Top	9240-039-001	9240-042-001	9240-045-001	1
14	Screw, 5/16- 10ABx3/8	9545-008-024	9545-008-024	9545-008-024	14
15	Impeller, w/set screws	9278-043-001	9278-038-004	9278-037-003	1
16	Harness -Temp Probe	9627-679-002	9627-679-002	9627-679-002	1
17	Wire Nut, #71B	8640-276-005	8640-276-005	8640-276-005	2
18	Bracket, Temp Probe	9029-197-001	NA	NA	1
19	Screw-5/16, 10ABx3/8	9545-008-024	NA	NA	1
20	Temp Probe	9501-004-002	9501-004-002	9501-004-002	1
21	Screw-Phillips, 8Bx1/4	9545-045-005	9545-045-005	9545-045-005	1
22	Vault, Coin	9942-039-002	9942-039-002	9942-039-002	1
*	Plate Assy/Coin vault mounting	9982-338-001	9982-338-001	9982-338-001	1
*	Nut/ Hexelastic stop	8640-413-004	8640-413-004	8640-413-004	2
23	Coin Shute	9940-016-001	9940-016-001	9940-016-001	1
*	Screw, 10Bx1/4	9545-008-001	9545-008-001	9545-008-001	1

**30lb Temp Probe**

**50Lb & 80Lb Temp Probe**

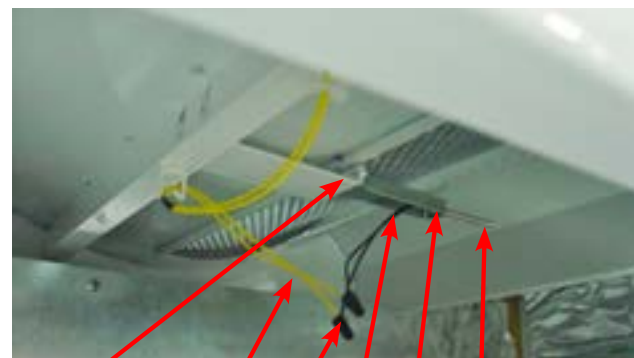

19 16 17 18 21 20

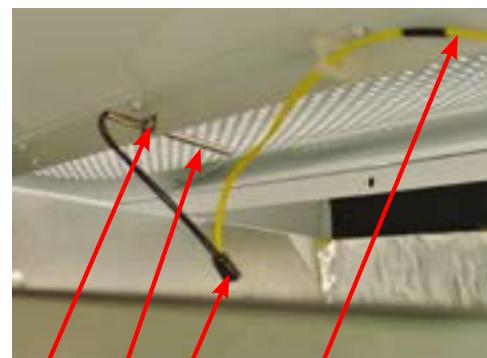

21 20 17 16

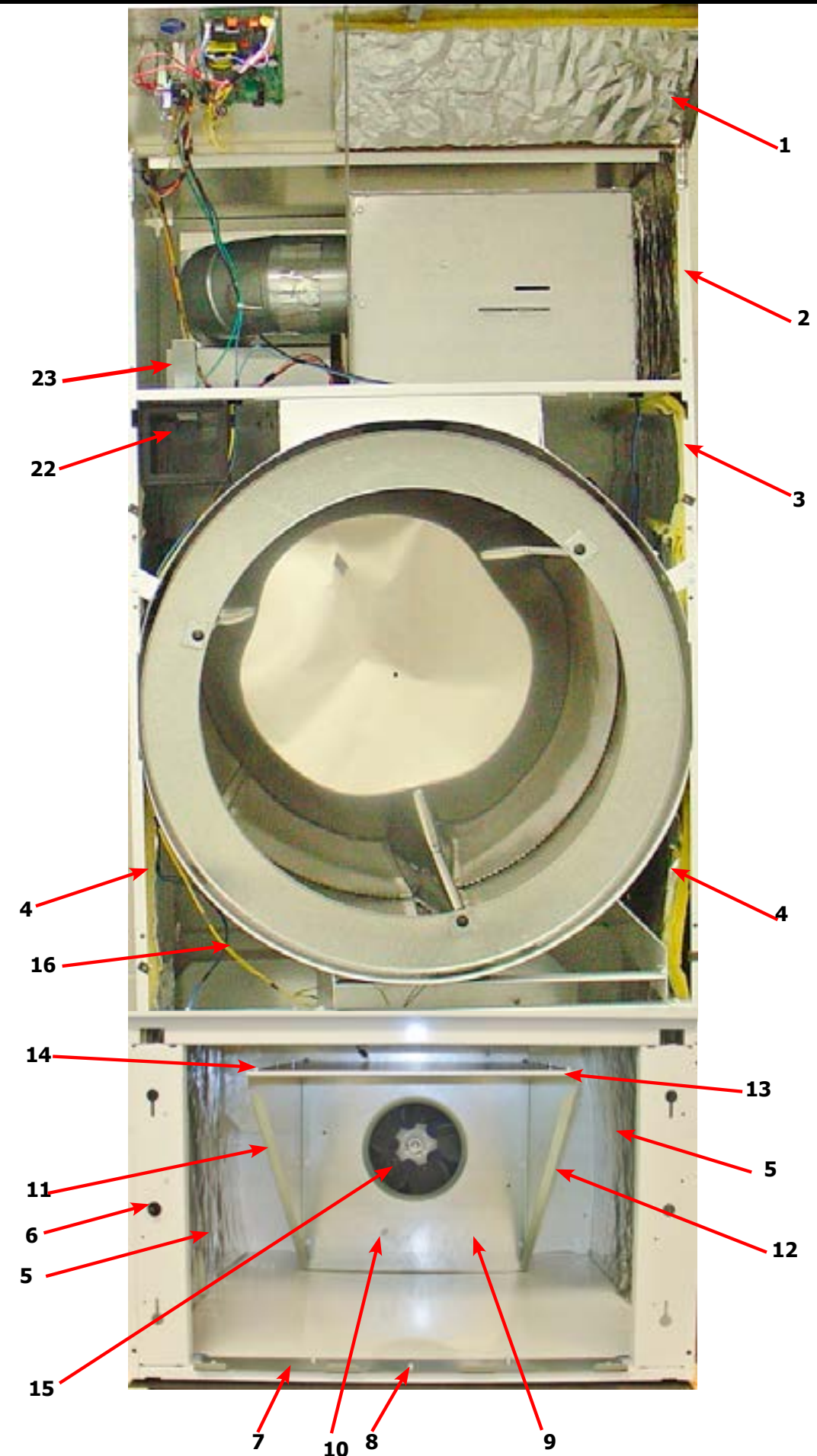

## Dryer Rear View 30Lb

Key	Description	T-30	QTY
1	Motor	9376-311-003	1
2	Pulley	9453-157-001	1
*	Set screw	9545-028-013	1
3	Plate, Motor mounting	9982-370-002	1
*	Gasket, Motor Plate	9206-428-001	1
4	Nut-3/8-16, Plate to cabinet	8640-415-004	4
*	Impeller w/set screw	9278-043-001	1
5	Screw, 5/16-18x5/8	9545-014-004	4
6	Nut, 3/8-16	8640-415-004	4
7	Support Arm, Intermediate pulley	9991-053-001	1
8	Bolt- 3/8-16x1 1/4	9545-029-010	3
9	Nut, Wizlock, 3/8x16	8640-415-004	3
*	Cap Screw, 3/8-16x1 1/2	9545-029-003	1
*	Snap Ring	9487-200-003	1
*	Washer-Flat, 3/8x1	8641-581-020	1
10	Idler Arm Assembly	9861-022-001	1
11	Washer-Flat, 3/8x1	8641-581-020	2
12	Pulley, Idler w/Bearings	9908-039-004	1
13	Bearing, Bronze	9036-145-002	2
14	Snap Ring	9487-200-003	1
15	Hook "S" type	9248-022-002	3
16	Chain, Spring tension	9099-012-002	1
17	Spring, tension	9534-319-002	1
18	Chain, Limit	9099-012-007	1
19	Belt Drive	9040-076-003	1
*	Tolerance Ring	9487-234-005	1
20	Pulley, Driven	9908-049-002	1
21	Washer-Flat, 1/2	8641-581-021	1
22	Washer-Lock, Ext. tooth, 1/2	8641-582-016	1
23	Bolt-3/4, 1/2-13x1/14	9545-017-019	1
24	Belt, Driven	9040-073-009	1

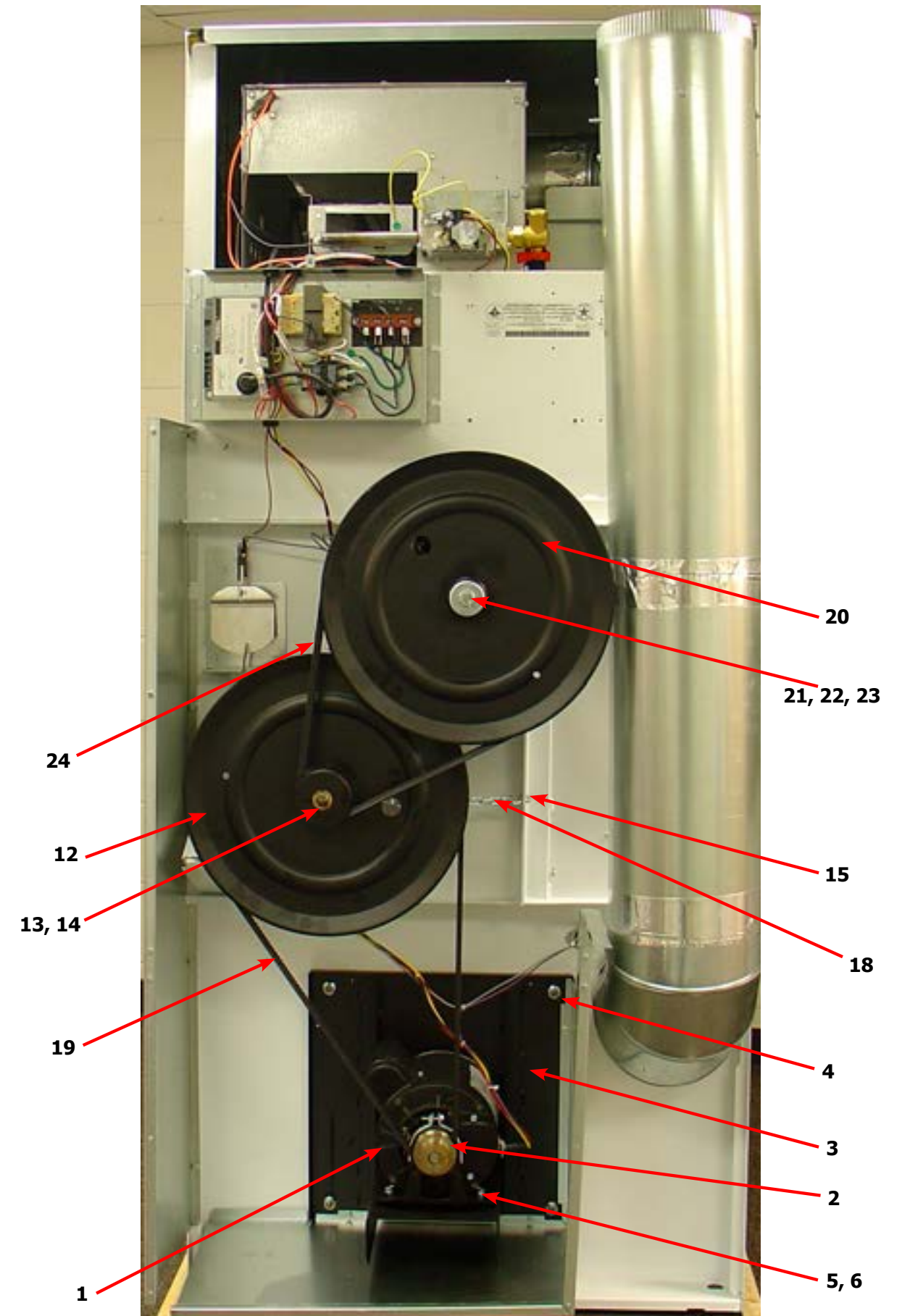
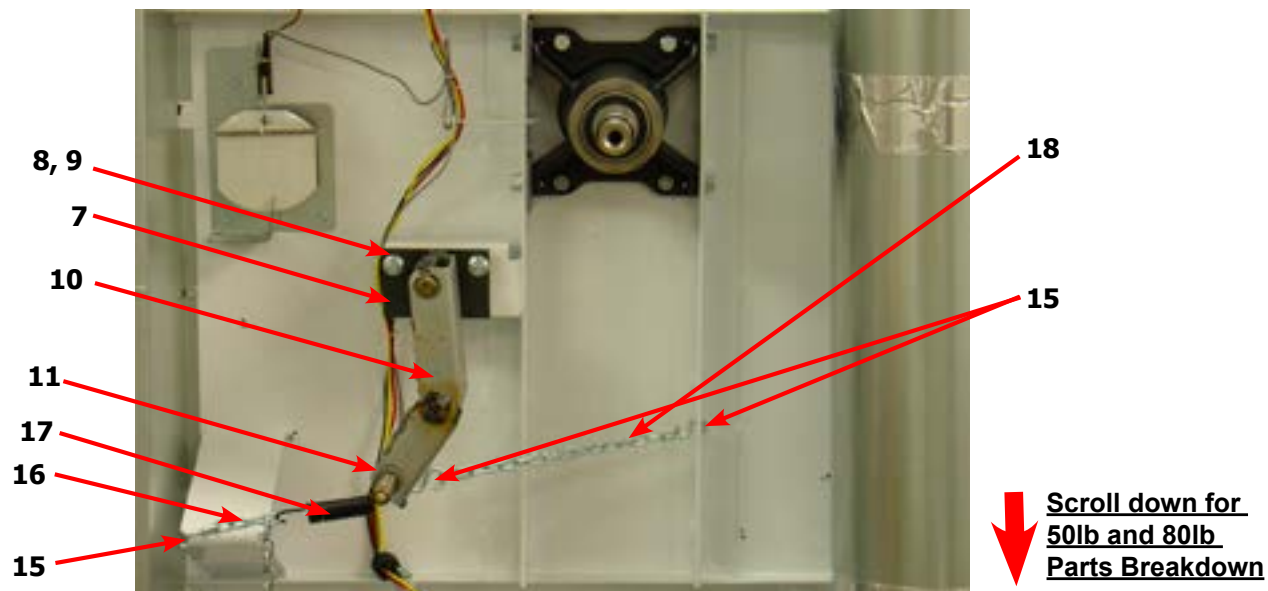

Key	Description	T-50	QTY
1	Motor	9376-317-003	1
*	Run Capacitor, Motor	5191-108-001	1
*	Start Capacitor, Motor	5191-109-001	1
2	Pulley	9453-169-013	1
*	Set screw	9545-028-013	1
3	Plate, Motor mounting	9982-370-002	1
*	Gasket, Motor Plate	9206-428-001	1
4	Nut-3/8-16, Plate to cabinet	8640-415-004	4
*	Impeller w/set screw	9278-038-004	1
5	Screw, 5/16-18x5/8	9545-014-004	4
6	Nut, 3/8-16	8640-415-004	4
7	Support Arm, Intermediate pulley	9991-053-002	1
8	Bolt- 3/8-16x1 1/4	9545-029-010	3
9	Nut, Wizlock, 3/8x16	8640-415-004	3
*	Cap Screw, 3/8-16x1 1/2	9545-029-012	1
*	Snap Ring	9487-200-003	1
*	Washer-Flat, 3/8x1	8641-581-035	1
10	Idler Arm Assembly	9861-022-002	1
*	Snap Ring (Support Arm keeper)	9487-200-003	1
*	Snap Ring	9487-200-003	1
*	Washer-Flat, 3/8x1	8641-581-035	1
11	Pulley, Idler w/Bearings	9908-048-003	1
12	Bearing, Bronze	9036-145-002	2
13	Snap Ring	9487-200-003	1
14	Hook "S" type	9248-022-002	3
15	Chain, Spring tension	9099-012-002	1
16	Spring, tension	9534-151-000	1
17	Belt Drive	9040-076-006	1
*	Tolerance Ring	9487-234-005	1
18	Pulley, Driven	9908-047-002	1
19	Washer-Flat, 1/2	8641-581-026	1
20	Washer-Lock, Ext. tooth, 1/2	8641-582-016	1
21	Bolt-3/4, 1/2-13x1/14	9545-017-009	1
22	Belt, Driven	9040-073-011	1
23	Thermostat-Overtemp, Reset	9576-207-006	1

## Dryer Rear View 50 Lb

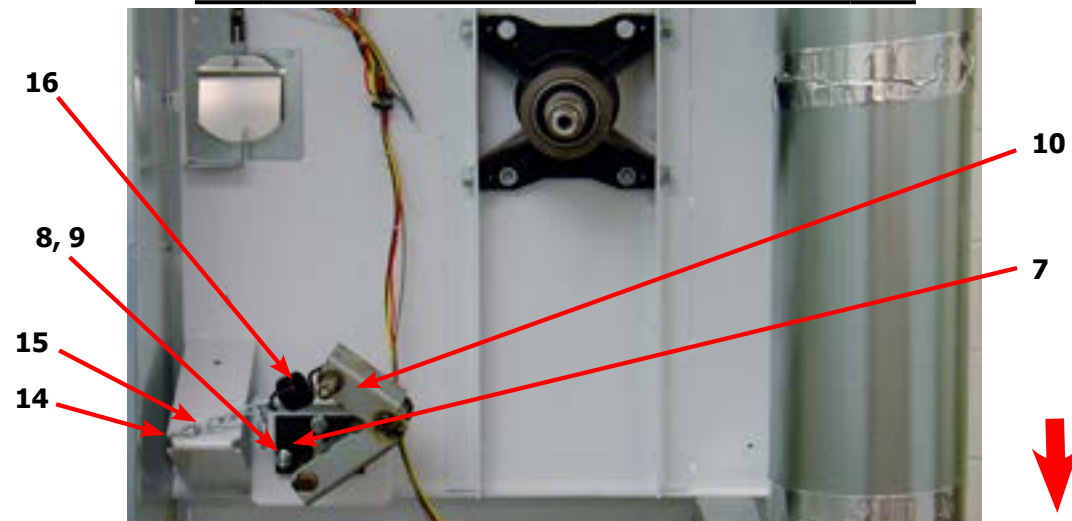

↓ [Scroll down for 80lb Parts Breakdown](#)

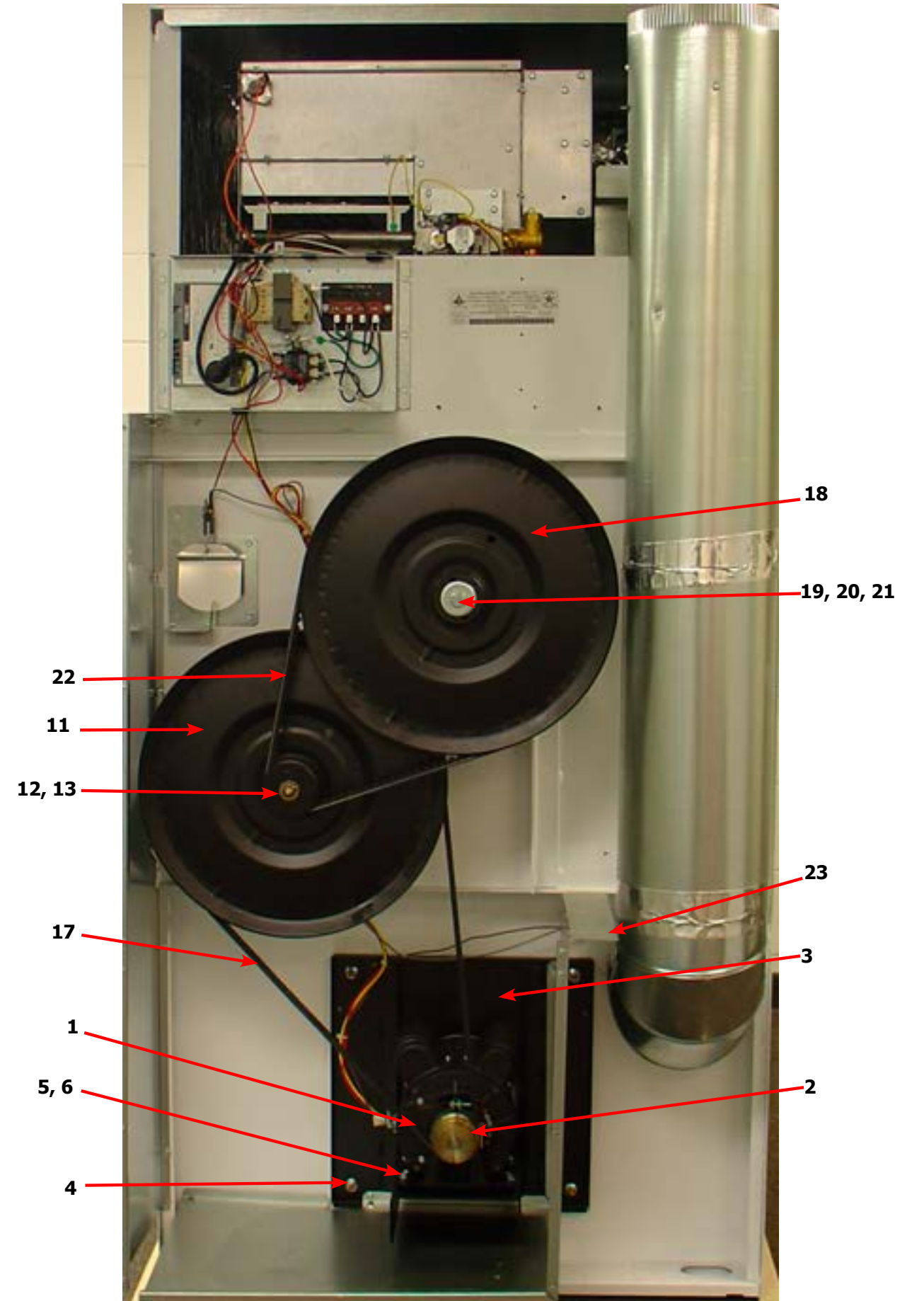

Key	Description	T-80	QTY
1	Motor	9376-317-003	1
*	Run Capacitor, Motor	5191-108-001	1
*	Start Capacitor, Motor	5191-109-001	1
2	Pulley	9453-157-001	1
*	Set screw	9545-028-013	1
3	Plate, Motor mounting	9982-372-002	1
*	Gasket, Motor Plate	9206-428-001	1
4	Nut-3/8-16, Plate to cabinet	8640-415-004	4
*	Impeller w/set screw	9278-037-003	1
5	Screw, 5/16-18x5/8	9545-014-004	4
6	Nut, 3/8-16	8640-400-003	4
*	Tolerance Ring	9487-234-001	1
7	Pulley, Driven	9908-043-002	1
8	Washer-Flat, 1/2	8641-581-026	1
9	Washer-Lock, Ext. tooth, 1/2	8641-582-016	1
10	Bolt-3/4, 1/2-13x1/4	9545-017-009	1
11	Support Arm, Intermediate pulley	9991-053-002	1
12	Bolt- 3/8-16x1 1/4	9545-029-010	3
13	Nut, Wizlock, 3/8x16	8640-415-004	3
*	Cap Screw, 3/8-16x1 1/2	9545-029-002	1
*	Snap Ring	9487-200-003	1
*	Washer-Flat, 3/8x1	8641-581-035	1
14	Idler Arm Assembly	9861-024-002	1
*	Snap Ring	9487-200-006	
*	Washer-Flat, 5/8	8641-581-039	1
15	Pulley, Idler w/Bearings	9908-042-006	1
*	Snapring, Inside-Bearing	9487-238-005	1
*	Bearing, Ball	9036-159-007	2
*	Spacer, Bearing	9538-173-002	1
16	Washer-Flat	8641-581-039	1
17	Nut, 5/8-11	8640-425-002	1
18	Hook "S" type	9248-022-002	3
19	Chain, Spring tension	9099-012-002	1
20	Spring, tension	9534-151-000	1
21	Belt Drive	9040-076-011	1
22	Belt, Driven	9040-073-012	1
23	Thermostat-Overtemp, Reset	9576-207-006	1

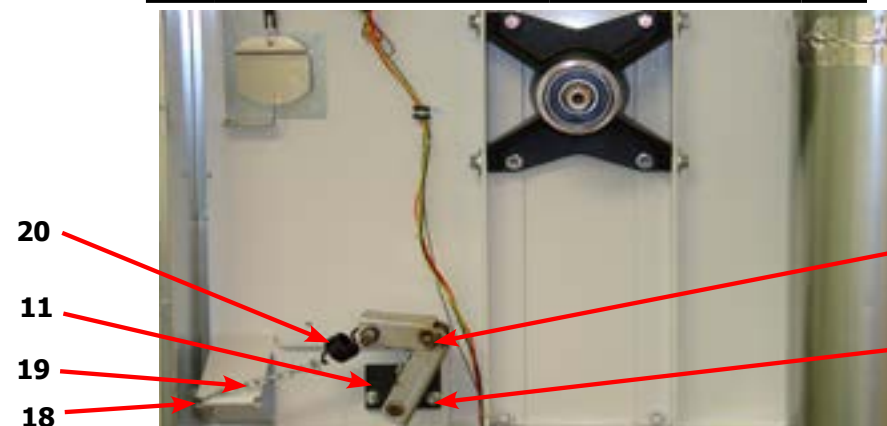

## Dryer Rear View 80 Lb

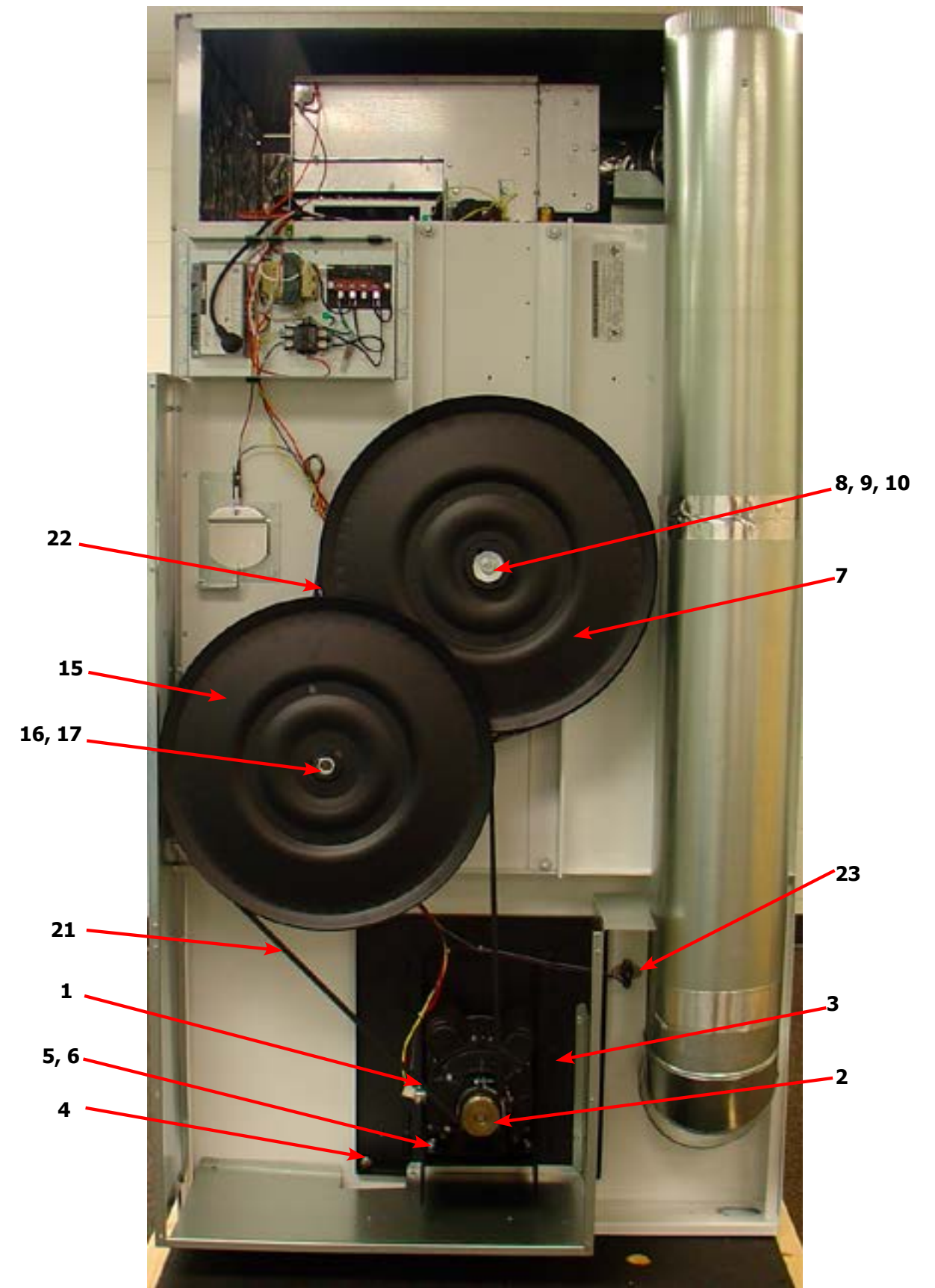

## Dryer Rear View-Guard & Exhaust

Key	Description	T-30	T-50	T80	QTY
1	Cover Cabinet	9074-347-001	9074-348-001	9074-349-001	1
*	Screw-5/16, 10ABx3/8	9545-008-024	9545-008-024	9545-008-024	AR
2	Cover-Control Box	9074-346-001	9074-346-001	9074-346-001	1
3	Screw-5/16, 10ABx3/8	9545-008-024	9545-008-024	9545-008-024	AR
4	Guard, RH	9208-093-001	9208-097-001	9208-101-001	1
*	Screw-5/16, 10ABx3/8	9545-008-024	9545-008-024	9545-008-024	AR
5	Guard Base & LH	9208-094-001	9208-098-001	9208-102-001	1
*	Screw-5/16, 10ABx3/8	9545-008-024	9545-008-024	9545-008-024	AR
6	Guard-Lower	9208-095-001	9208-099-002	9208-103-001	1
7	Screw-5/16, 10ABx3/8	9545-008-024	9545-008-024	9545-008-024	AR
8	Guard-upper	9208-096-001	9208-100-001	9208-104-001	1
*	Screw-5/16, 10ABx3/8	9545-008-024	9545-008-024	9545-008-024	AR
9	Elbow-90 degree, 8"	9142-039-001	9142-039-001	9142-039-001	1
10	Pipe-Duct, 8"	9109-121-001	9109-121-001	9109-121-002	1
11	Tee-Duct, Recirculation, 8"-6"	9810-018-001	9810-018-001	9810-019-001	1
12	Damper	9125-002-001	9125-002-001	9125-008-001	1
*	Pin-Damper, Hinge	9451-146-002	9451-146-002	9451-146-002	1
*	Nut-Spring	8520-141-000	8520-141-000	8520-141-000	2
13	Bracket-Recirculation Duct, Small	9029-228-001	9029-228-001	9028-228-001	1
14	Pipe-Duct, 6"	9109-122-001	9109-122-002	9109-122-003	1
15	Bracket-Duct, Recirculation Large	9029-246-001	9029-247-001	9029-247-001	1
16	Elbow-90 degree, 6"	9142-039-002	9142-039-002	9142-039-002	1
*	Booklet-Owners	8514-208-001	8514-208-001	8514-208-001	1
17	Diagram & Schematics	9506-474-001	9506-474-001	9506-474-001	1
18	Label-Warning & Notice	8502-600-001	8502-600-001	8502-600-001	1
19	Label-Instructions	8502-645-001	8502-645-001	8502-645-001	1
20	Decal-Lighting & Clearance	8527-151-001	8527-151-001	8527-151-001	1
21	Label-High Voltage	8502-614-004	8502-614-004	8502-614-004	1
*	8" Slide Open Clean Out Duct	9973-034-001	9973-034-001	9973-034-001	1

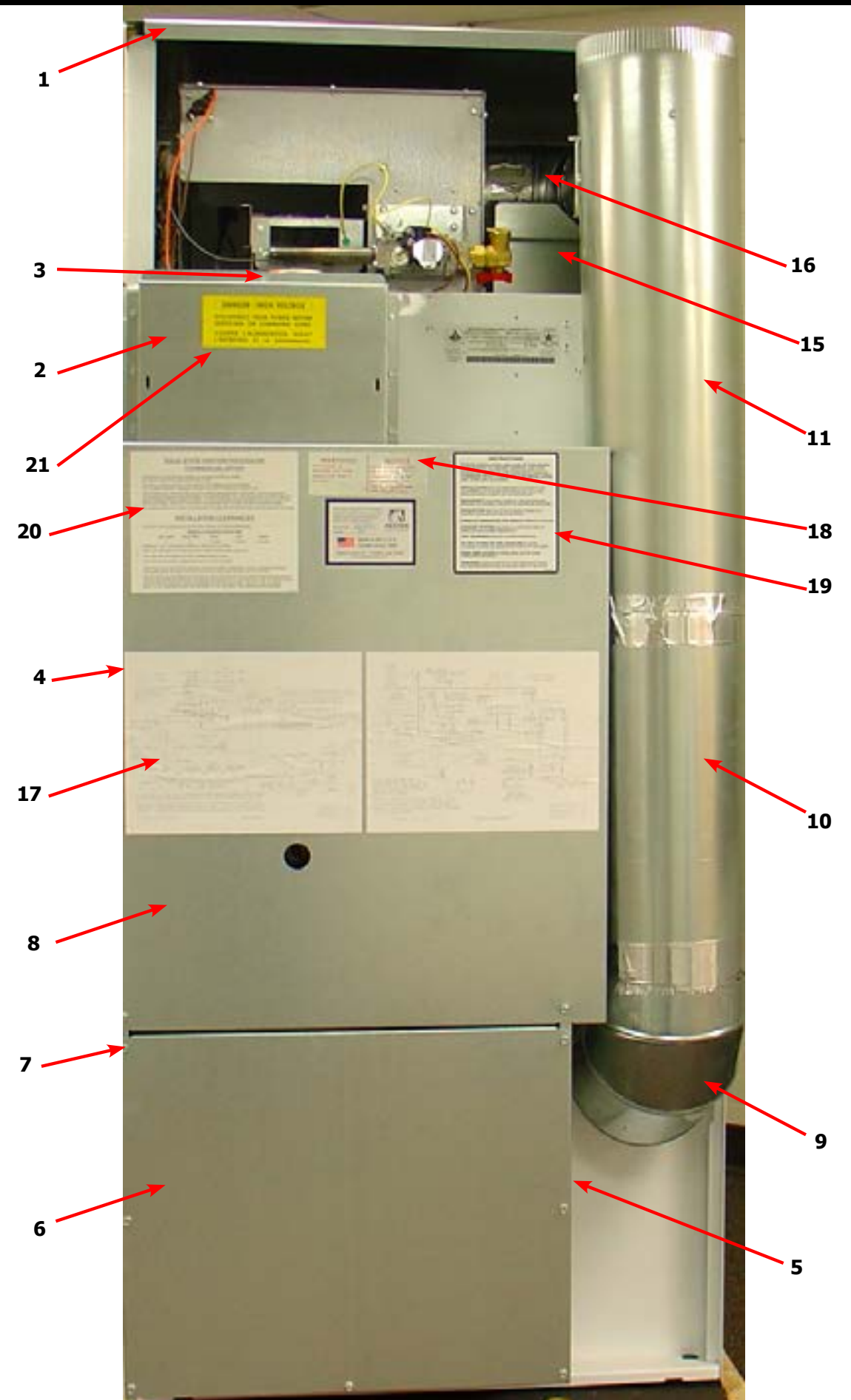
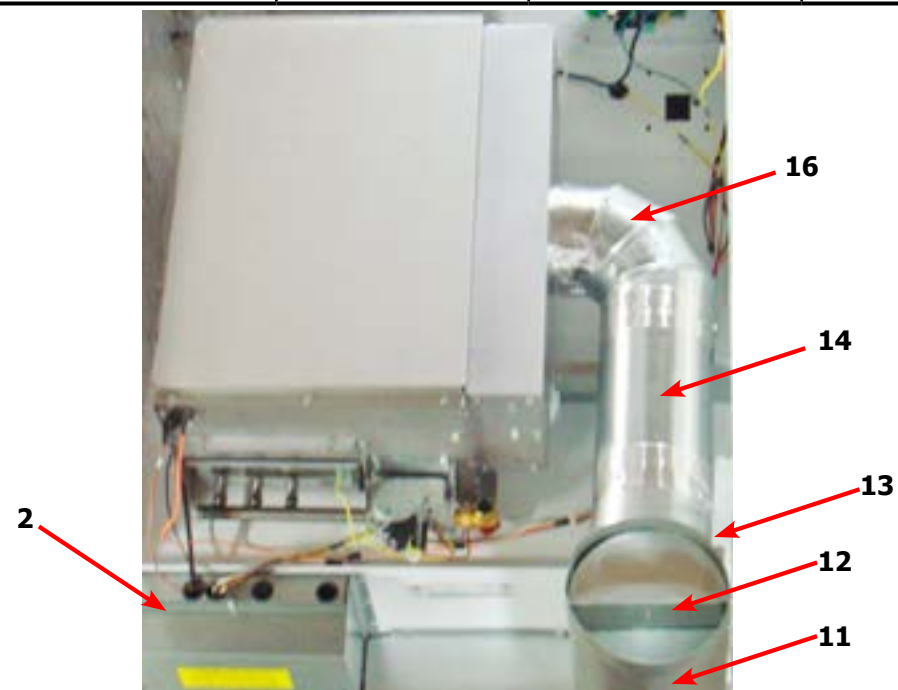

## Dryer Rear View-Bearing Housing 30Lb

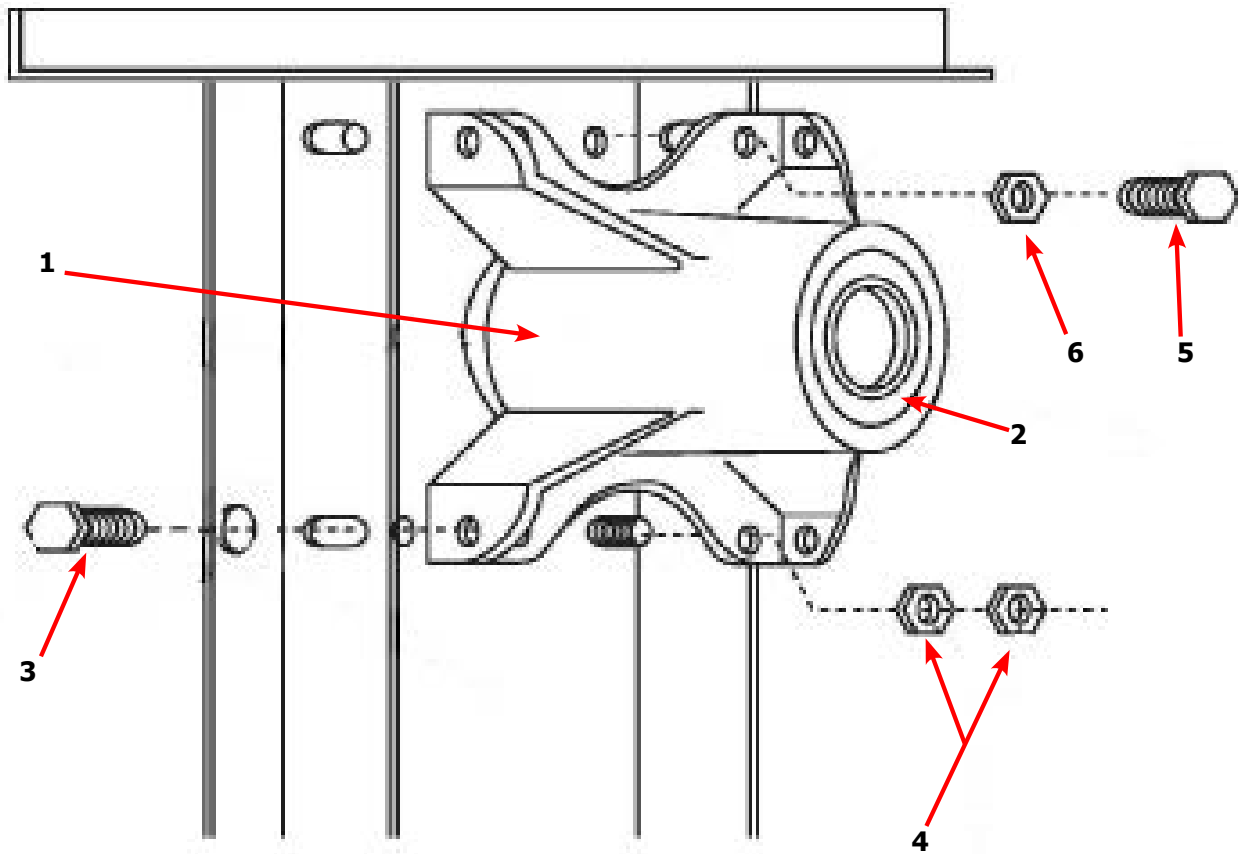

Key	Description	T-30	QTY
*	Bearing Housing Complete Assy (Includes bearings & Spacer)	9803-160-003	1
1	Housing, Bearing	9241-161-002	1
*	Bearing, Ball, Front	9036-130-001	1
*	Spacer, Bearing	9538-139-002	1
2	Bearing, Ball, Rear	9036-130-001	1
3	Screw-Wizlock, 3/8-24x3/4	9545-049-002	4
4	Nut, 5/16-18	8640-400-002	4
5	Screw, 3/8-24x1	9545-049-001	2
6	Nut, 3/8-24	8640-415-002	2
*	Shim, Tumbler	9538-139-002	AR

↓ Scroll down for  
50lb and 80lb  
Parts Breakdown

## Dryer Tumbler Group 30Lb

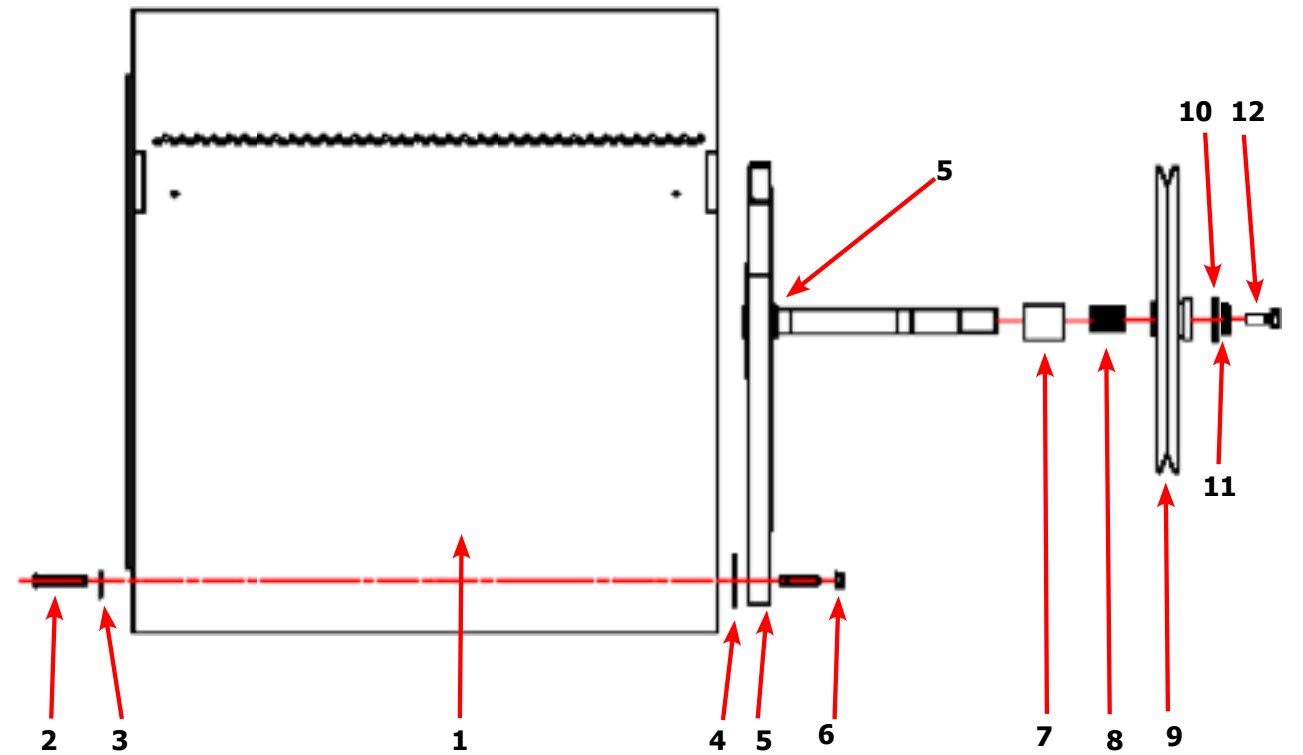

Key	Description	T-30	QTY
*	Tumbler Assy Complete W/Spider (GALV)	9848-142-001	1
1	Tumbler Assy (Galvanized)	9848-126-001	1
1	Tumbler Assy Complete W/Spider (SS & Galv front)	9848-142-002	1
1	Tumbler Assy (Stainless Galvanized front)	9848-126-002	1
2	Rod, Tumbler	9497-019-003	3
3	Washer, Special	8641-554-001	3
4	Shim	9552-013-003	AR
5	Spider Assy	9568-015-001	1
6	Nut, Wiz Lock	8640-415-004	3
7	Spacer-Shaft	9538-164-001	1
8	Tolerance Ring	9487-234-005	1
9	Pulley, Driven	9908-049-002	1
10	Washer -Flat	8641-581-026	1
11	LockWasher - IntTooth, 1"	8641-582-016	1
12	Screw, 1/2-13x1 1/4	9545-017-009	1

↓ Scroll down for  
50lb and 80lb  
Parts Breakdown

## Dryer Rear View-Bearing Housing 50Lb

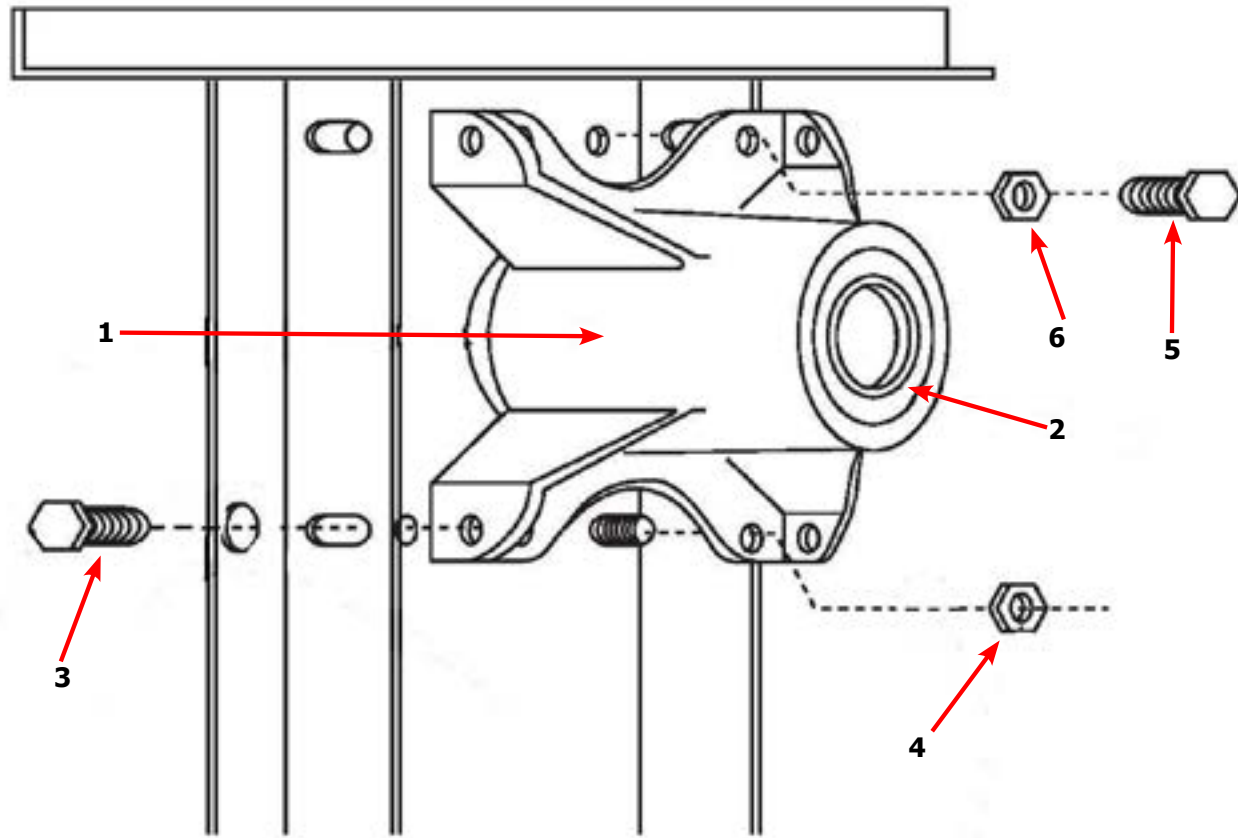

Key	Description	T-50	QTY
	Bearing Housing Complete Assy (Includes bearings & Spacer)	9803-201-001	1
1	Housing, Bearing	9241-189-002	1
*	Bearing, Ball, Front	9036-159-001	1
*	Spacer, Bearing	9538-183-001	1
2	Bearing, Ball, Rear	9036-159-003	1
3	Screw-Wizlock, 1/2-13x3/4	9545-017-017	4
4	Nut, 1/2-13	8640-417-002	2
5	Screw, 1/2-13x1 1/2	9545-017-018	2
6	Nut, 1/2-13	8640-417-002	2

↓ **Scroll down for  
80lb Parts  
Breakdown**

## Dryer Tumbler Group 50Lb

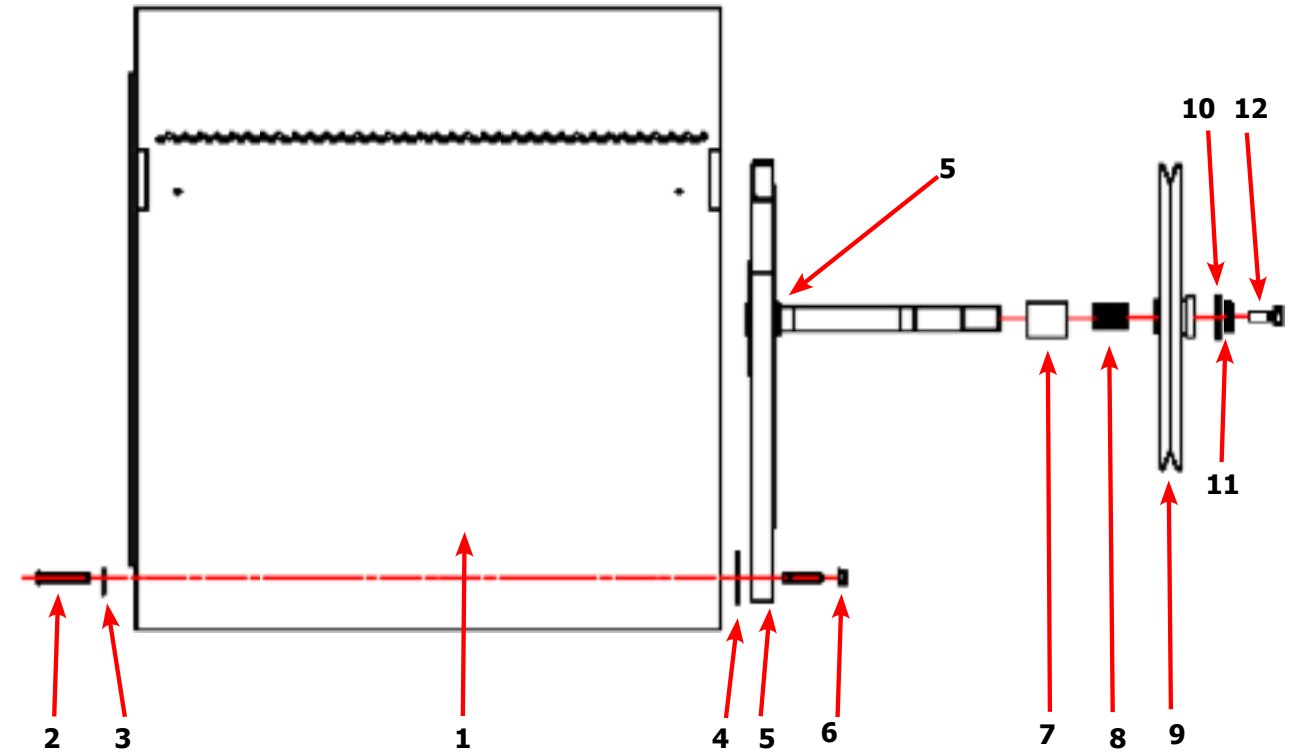

Key	Description	T-50	QTY
*	Tumbler Assy Complete W/Spider (GALV)	9848-131-001	1
1	Tumbler Assy (Galvanized)	9848-130-001	1
*	Tumbler Assy Complete W/Spider (SS & Galv front)	9848-131-002	1
1	Tumbler Assy (Stainless Galvanized front)	9848-130-002	1
2	Rod, Tumbler	9497-226-002	3
3	Washer, Special	8641-590-002	3
4	Shim	9552-013-000	AR
5	Spider Assy	9568-013-001	1
6	Nut, Wiz Lock	8640-417-005	3
7	Spacer-Shaft	9538-184-001	1
8	Tolerance Ring	9487-234-005	1
9	Pulley, Driven	9908-047-002	1
10	Washer -Flat	8641-581-026	1
11	LockWasher - IntTooth, 1"	8641-582-016	1
12	Screw, 1/2-13x1 1/4	9545-017-009	1

↓ **Scroll down for  
80lb Parts  
Breakdown**

## Dryer Rear View-Bearing Housing 80Lb

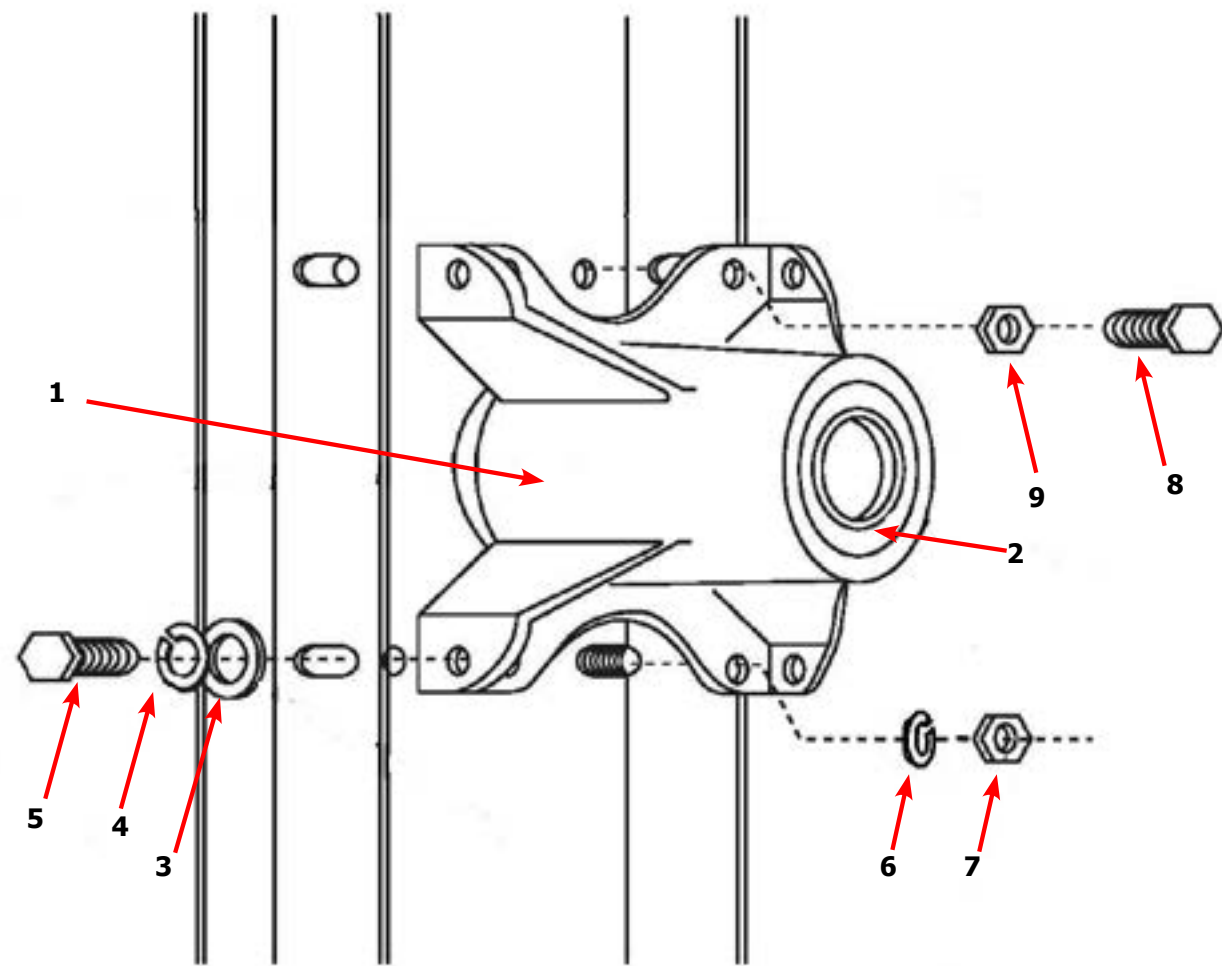

Key	Description	T80	QTY
	Bearing Housing Complete Assy (Includes bearings & Spacer)	9803-189-001	
1	Housing, Bearing	9241-183-003	
*	Bearing, Ball, Front	9036-159-001	
*	Spacer, Bearing		
2	Bearing, Ball, Rear	9036-159-002	
3	Washer, Flat 1/2	8641-581-026	
4	Lock Washer Spring, 1/2	8641-582-004	
5	Screw, 1/2-13x1	9545-017-004	
6	Lock Washer Spring, 1/2	8641-582-004	
7	Nut, 7/16-14	8640-416-001	
8	Screw, 7/16-14x1 1/2	9545-059-003	
9	Nut, 7/16-14	8641-416-001	

## Dryer Tumbler Group 80Lb

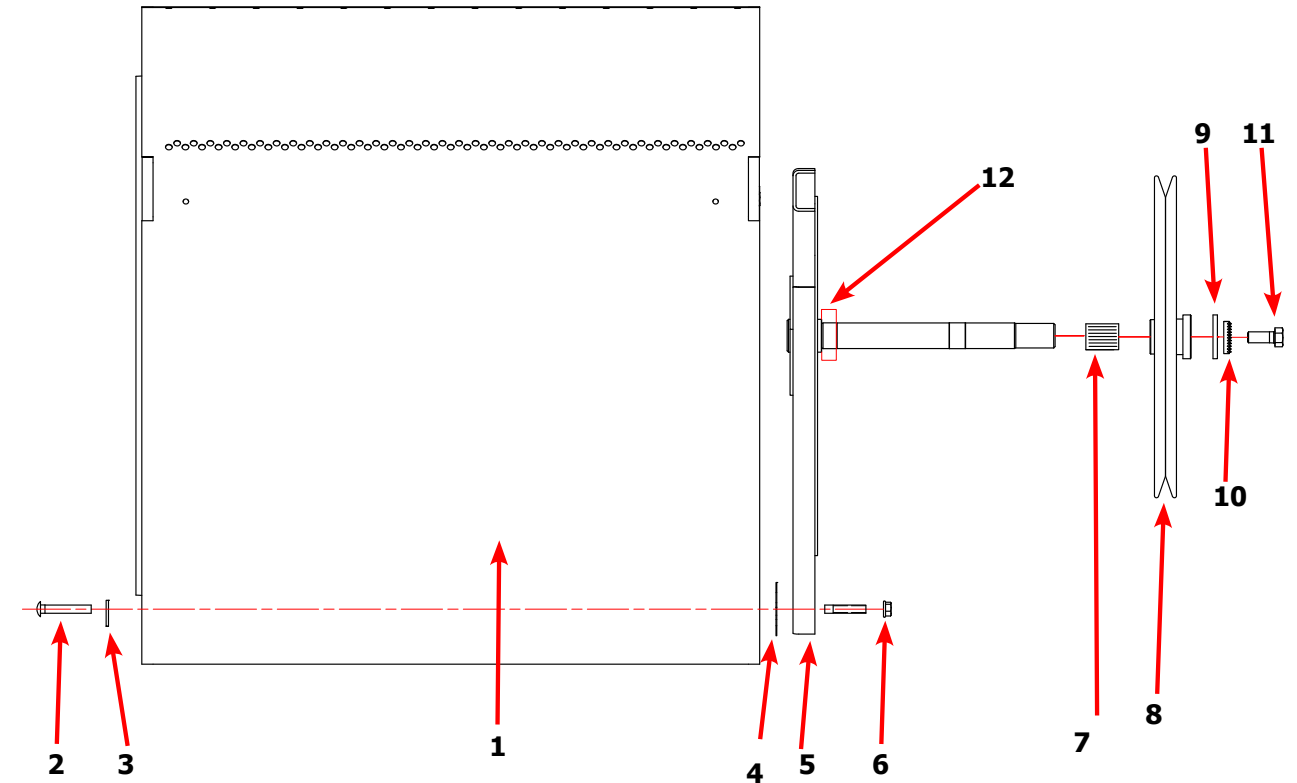

Key	Description	T80	QTY
*	Tumbler Assy Complete W/Spider (GALV)	9848-139-001	1
1	Tumbler Assy (Galvanized)	9848-138-001	1
1	Tumbler Assy Complete W/Spider (SS & Galv front)	9848-139-002	1
1	Tumbler Assy (Stainless Galvanized front)	9848-138-002	1
2	Rod, Tumbler	9497-266-001	4
3	Washer, Special	8641-590-001	4
4	Shim	9552-013-000	AR
5	Spider Assy w/Front Bearing	9873-008-001	1
6	Nut, Wiz Lock	8640-417-005	4
7	Tolerance Ring	9487-234-001	1
8	Pulley, Driven	9908-043-002	1
9	Washer -Flat	8641-581-026	1
10	LockWasher - IntTooth, 1"	8641-582-016	1
11	Screw, 1/2-13x1 1/4	9545-017-009	1
12	Bearing, Front	9036-159-002	1

# Dryer Burner Housing Group 30Lb

Key	Description	Part Number	Qty
*	Housing Assembly, Burner	9803-210-001	1
1	Panel-Burner Housing, Side Left	9454-845-001	1
2	Baffle-Burner Housing, Center	9049-091-001	1
3	Panel-Burner Housing, Top	9454-871-001	1
4	Panel-Burner Housing, Front	9454-847-001	1
5	Panel-Burner Housing, Back	9454-848-001	1
6	Baffle-Burner Housing, Recirculation	9049-092-001	1
7	Baffle-Burner Housing, Front	9049-093-001	1
8	Duct Adaptor, 6"x3" long	9109-120-01	1
9	Burner, Main	9048-021-001	2
10	Bracket-Support, Electrode	9029-214-001	1
11	Bracket-Support, Gas Valve	9029-227-001	1
12	Electrode-Ignition	9875-002-003	1
13	Control Assy, Gas Valve, White Rodgers 36J	9857-192-001	1
14	Manifold Assy	9381-009-007	1
15	Valve-Gas Shutoff, (Optional)	9379-196-001	1
16	Thermostat-HI-Limit	9576-203-002	
17	Screw, 10ABx3/8	9545-008-024	24
18	Screw, 10ABx1/4	9545-008-006	17
19	Orifice-Natural, .125	9425-069-023	2
*	Orifice-LP, #48	9425-069-003	2
*	Kit, LP Conversion, White Rodgers	9732-102-018	1
20	Bracket-Support, Burner	9029-225-001	1
21	Panel-Burner Housing, Side Right	9454-861-001	1
22	Screw, 10-32TTx1/2 Green	9545-008-027	3
23	Screw, 8-32x3/8	9545-010-014	4

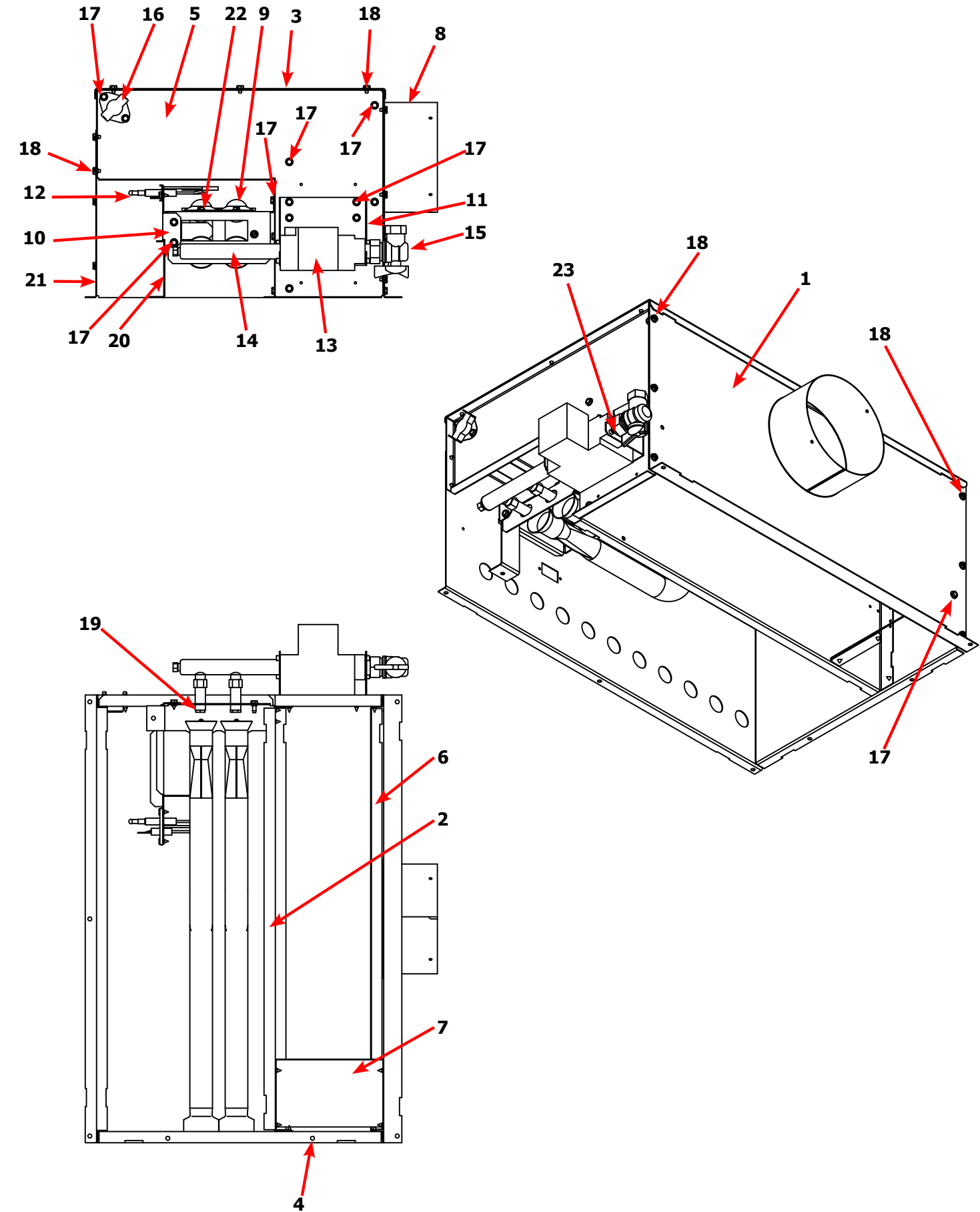



**Scroll down for  
50lb and 80lb  
Parts Breakdown**

# Dryer Burner Housing Group 50Lb

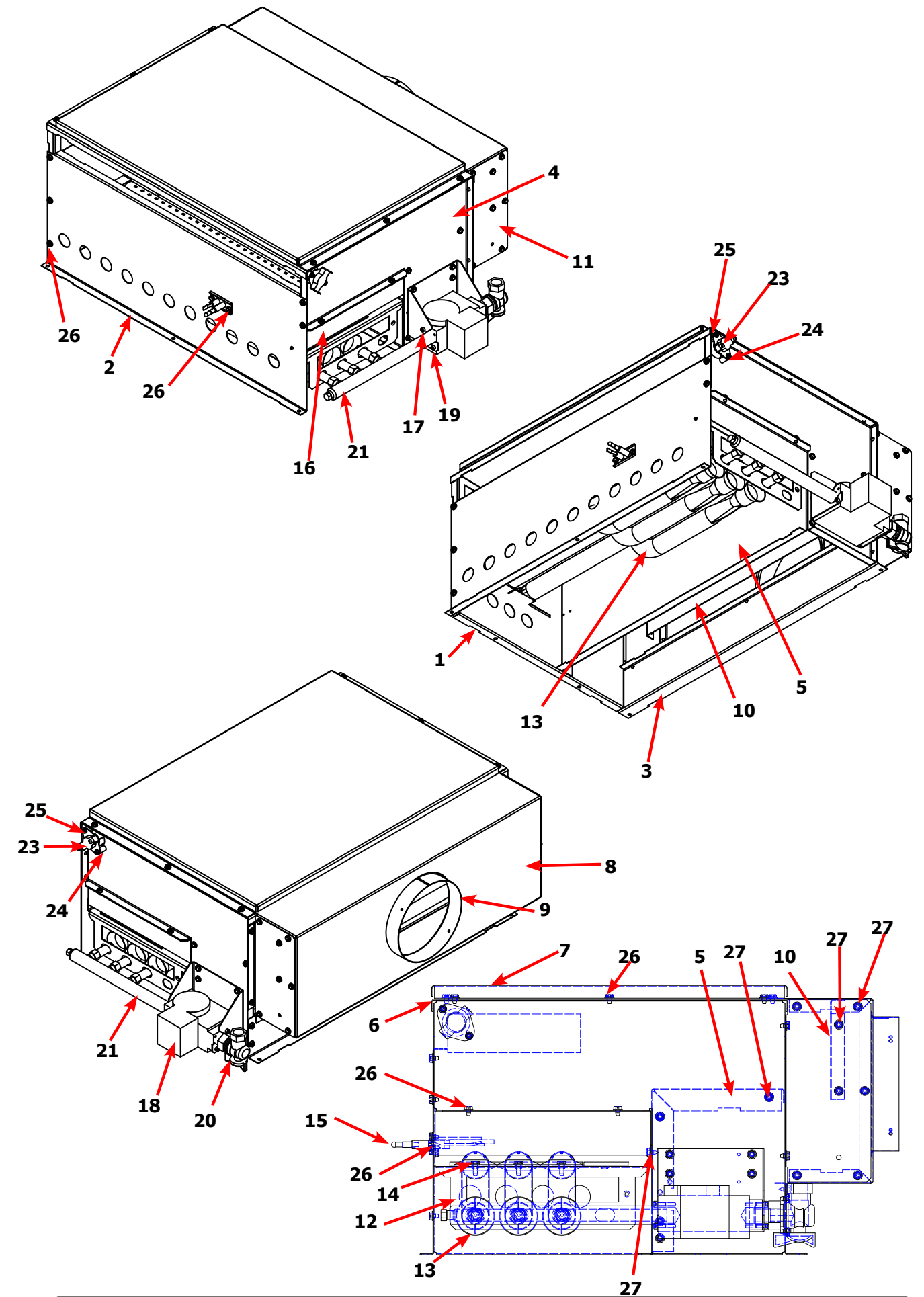
Key	Description	Part Number	Qty
	Housing Assembly, Burner	9803-211-001	1
1	Panel-Burner Housing, Front	9454-863-001	1
2	Panel-Burner Housing, Side Right	9454-861-001	1
3	Panel-Burner Housing, Side Left	9454-862-001	1
4	Panel-Burner Housing, Back	9454-864-001	1
5	Baffle-Burner Housing, Center	9049-098-001	1
6	Panel-Burner Housing, Top	9454-849-001	1
7	Panel-Burner Housing, Top	9074-343-001	1
8	Baffle-Burner Housing, Extention	9049-100-001	1
9	Duct Adaptor, 6"x1.25" long	9109-120-003	1
10	Baffle-Burner Housing, Recirculation	9049-099-001	1
11	Side-Extention Baffle, Burner Housing	9551-049-001	2
12	Bracket-Support, Burner	9029-213-001	1
13	Burner, Main	9048-021-001	3
14	Screw, 10T-32x1/2	9545-008-008	3
15	Electrode-Ignition	9875-002-003	1
16	Cover-Burner, Intet	9074-344-001	1
17	Bracket-Support, Gas Valve	9029-227-001	1
18	Control Assy, Gas Valve, White Rodgers 36J	9857-192-001	1
19	Screw, #8-32x3/8	9545-010-014	4
20	Valve-Gas Shutoff, (Optional)	9379-196-001	1
21	Manifold Assy	9381-010-003	1
*	Orfice-Natural, #30	9425-069-002	3
*	Orfice-LP, #48	9425-069-003	3
*	Kit, LP Conversion, White Rodgers	9732-102-017	1
23	Thermostat-HI-Limit	9576-203-002	1
24	Spacer-1/4x5/8 long	9538-166-009	2
25	Screw-8Bx1	9545-045-013	2
26	Screw, 10Bx1/4	9545-008-001	22
27	Screw, 10ABx3/8	9545-008-024	31





**Scroll down for  
80lb Parts  
Breakdown**

# Dryer Burner Housing Group 80Lb

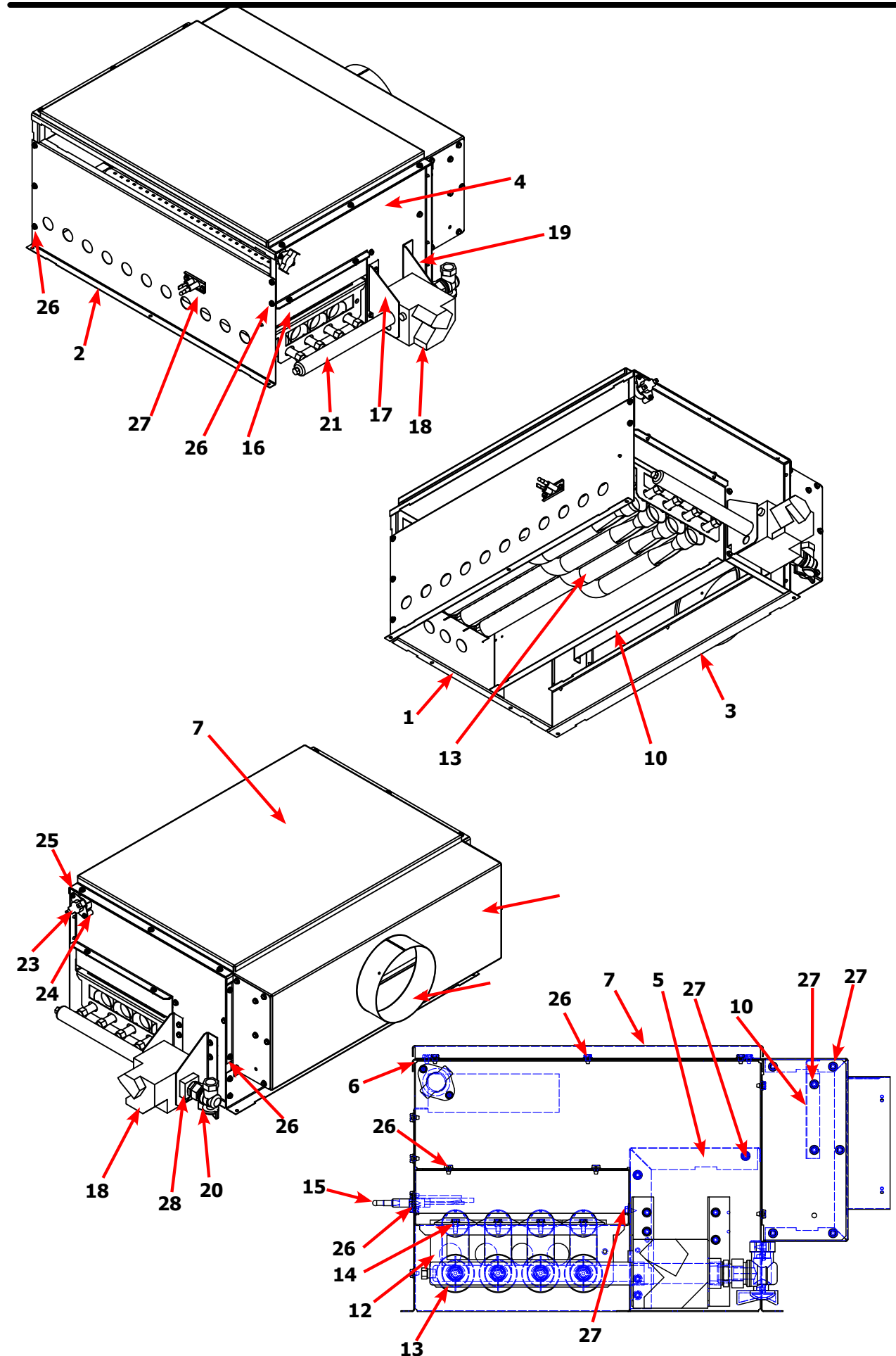
Key	Description	Part Number	Qty
	Housing Assembly, Burner	9803-212-001	1
1	Panel-Burner Housing, Front	9454-863-001	1
2	Panel-Burner Housing, Side Right	9454-861-001	1
3	Panel-Burner Housing, Side Left	9454-862-001	1
4	Panel-Burner Housing, Back	9454-864-001	1
5	Baffle-Burner Housing, Center	9049-098-001	1
6	Panel-Burner Housing, Top	9454-849-001	1
7	Panel-Burner Housing, Top	9074-343-001	1
8	Baffle-Burner Housing, Extention	9049-100-001	1
9	Duct Adaptor, 6"x1.25" long	9109-120-002	1
10	Baffle-Burner Housing, Recirculation	9049-099-001	1
11	Side-Extention Baffle, Burner Housing	9551-049-001	2
12	Bracket-Support, Burner	9029-213-001	1
13	Burner, Main	9048-021-001	4
14	Screw, 10T-32x1/2	9545-008-008	4
15	Electrode-Ignition	9875-002-003	1
16	Cover-Burner, Intet	9074-344-001	1
17	Bracket-Support, Gas Valve	9029-234-001	1
18	Control Assy,Gas Valve, White Rodgers 36J	9857-193-001	1
19	Bracket-support, Gas Valve Left hand	9029-235-001	4
20	Valve-Gas Shutoff, (Optional)	9379-196-001	1
21	Manifold Assy	9381-014-001	1
22	Orifice-Natural, #29	9425-069-021	3
*	Orifice-LP, #46	9425-069-022	3
*	Kit, LP Conversion, White Rodgers	9732-102-023	1
23	Thermostat-HI-Limit	9576-203-002	1
24	Spacer-1/4x5/8 long	9538-166-009	2
25	Screw-8Bx1	9545-045-013	2
26	Screw, 10Bx1/4	9545-008-001	22
27	Screw, 10ABx3/8	9545-008-024	31
28	Bushing-Reducer, 3/4x1/2	8615-104-009	1

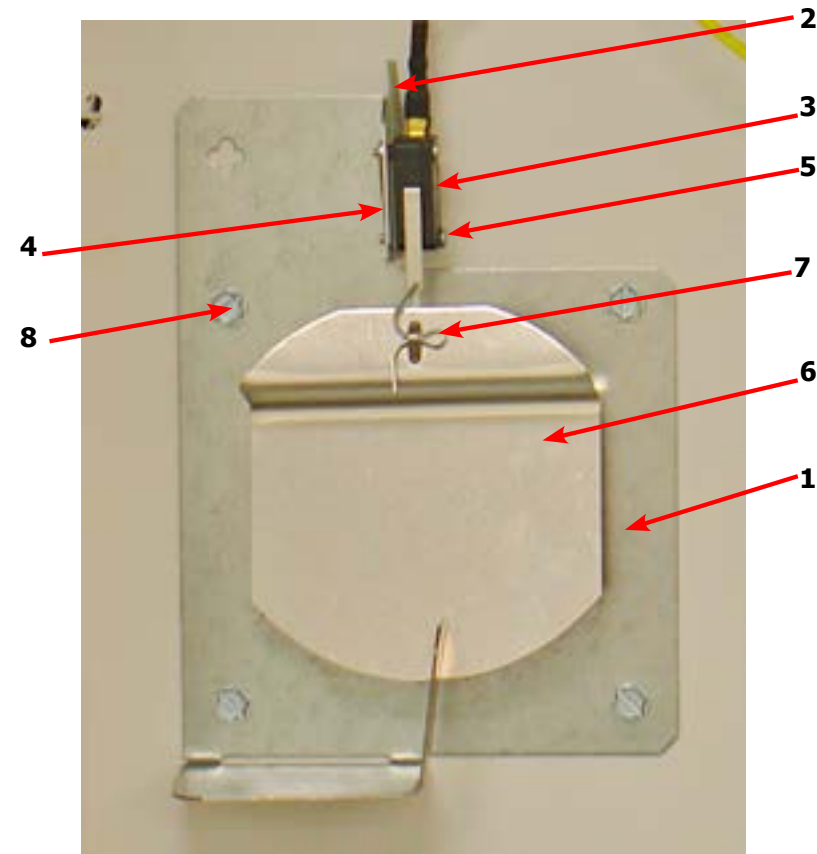



Key	Description	T-30	T-50	T80	QTY
*	Air Flow switch Assy	9801-095-002	9801-098-002	9801-098-002	1
1	Bracket-Airflow switch	9029-174-002	9029-200-002	9029-200-002	1
2	Shield-Switch	9550-169-003	9550-169-003	9550-169-003	1
3	Switch-Micro	9539-461-009	9539-461-009	9539-461-009	1
4	Nut-Twin, 4-40	8640-401-001	8640-401-001	8640-401-001	1
5	Screw-.625, 4-40	9545-020-001	9545-020-001	9545-020-001	2
6	Actuator-Air Flow Switch	9008-007-001	9008-007-001	9008-007-001	1
7	Pin-Cotter, .09375x.75	9451-169-002	9451-169-002	9451-169-002	1
	Screw, 10Bx1/4	9545-008-001			3
			9545-008-001	9545-008-001	4

## Electrical Box / Ignition Control

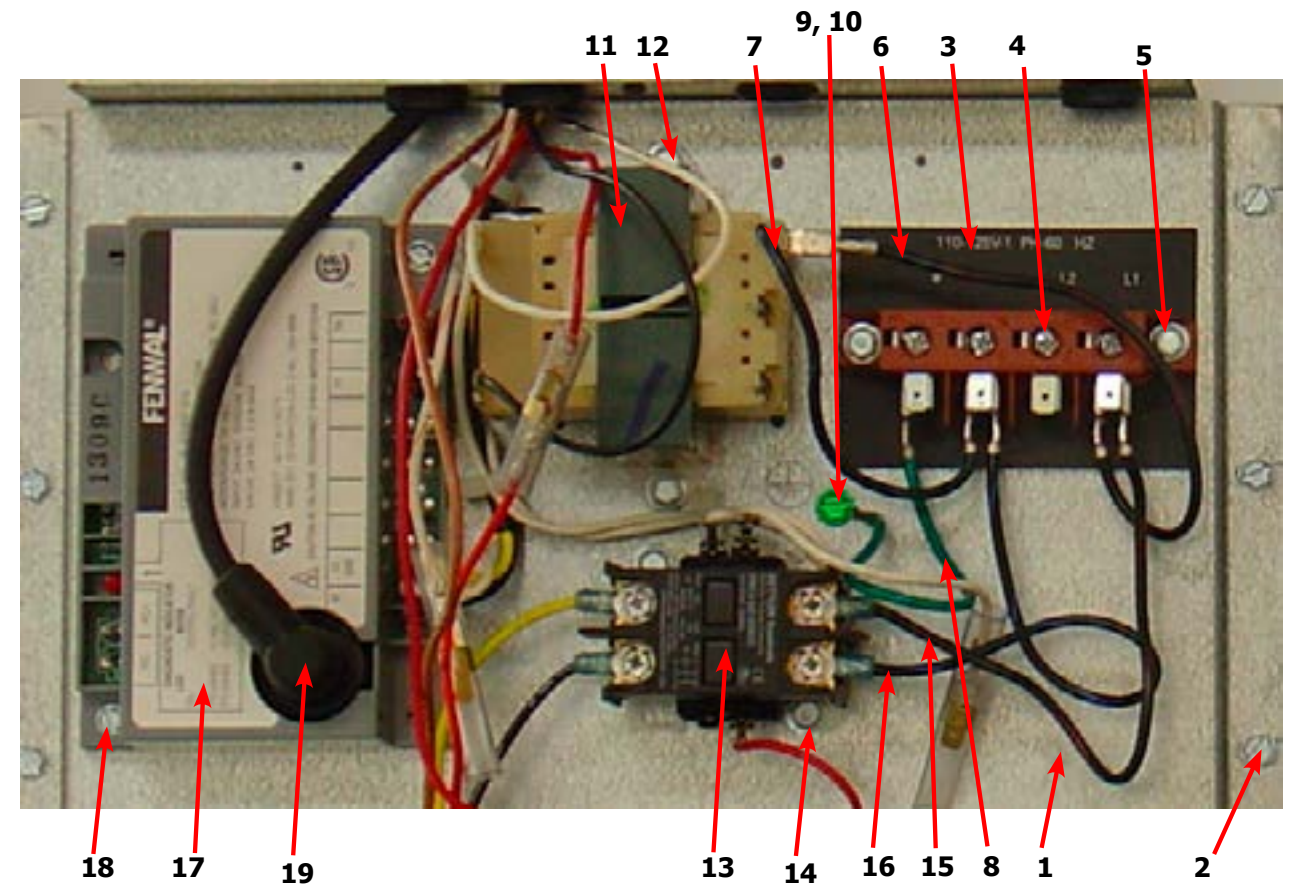

Key	Description	T-30	T-50	T80	QTY
1	Wrapper-Control Box	9636-200-001	9636-200-001	9636-200-001	1
2	Screw, 5/16-10AB-3/8	9545-008-001	9545-008-001	9545-008-001	6
*	Cover-Control Box	9074-346-001	9074-346-001	9074-346-001	1
*	Screw, 5/16-10AB-3/8	9545-008-024	9545-008-024	9545-008-024	1
3	Strip-Marker, Terminal	9558-029-005	9558-029-005	9558-029-005	1
4	Terminal Block Assy-Power, 4Pole	9897-035-001	9897-035-001	9897-035-001	1
5	Screw, 5/16-10AB-3/8	9545-008-024	9545-008-024	9545-008-024	2
6	Wire assy-Blk/Red, 6 1/2"	8220-001-230	8220-001-230	8220-001-230	1
7	Wire assy-Blk/Blu, 6 1/2"	8220-001-231	8220-001-231	8220-001-231	1
8	Wire Assy, GRN, 7"	8220-001-478	8220-001-478	8220-001-478	1
9	Screw- 10-32TTx1/2 GRN	9545-008-027	9545-008-027	9545-008-027	1
10	Lockwasher, External tooth	8641-582-006	8641-582-006	8641-582-006	1
11	Transformer, w/Circuit braker	8711-007-002	8711-007-002	8711-007-002	1
12	Screw, 5/16-10AB-3/8	9545-008-024	9545-008-024	9545-008-024	2
13	Relay-Motor, 30Amp, 24VAC	5192-299-002	5192-299-002	5192-299-002	1
14	Screw, 5/16-10AB-3/8	9545-008-024	9545-008-024	9545-008-024	2
15	Wire assy-Blk/Red, 9"	8220-146-001	8220-146-001	8220-146-001	1
16	Wire assy-Blk/Blu, 9"	8220-146-002	8220-146-002	8220-146-002	1
17	Control Assy, Ignition (Module)	9857-182-001	9857-182-001	9857-182-001	1
18	Screw-8Bx3/4"	9545-045-007	9545-045-007	9545-045-007	2
*	Harness, Ignition Module	9627-867-003	9627-867-003	9627-867-003	1
19	Wire Assy- High Voltage Lead	9631-403-009	9631-403-009	9631-403-009	1









DCBD30.50.80KC\_-39 230VAC 1 PH 50Hz

Key	Description	T-30	T-50	T80	QTY
	Motor	9376-311-004	9376-317-004	9376-317-004	1
	Pulley	9453-169-009	9435-169-014	9453-169-009	1
	Strip Terminal Marker	9558-029-004	9558-029-004	9558-029-004	1
	Wiring Label-Schematic/Diagram	9506-496-001	9506-496-001	9506-496-001	1
	Switch Assembly-Air flow	9801-095-002			
	Bracket-Airflow switch	9029-174-002			
	Switch Micro	9539-461-009			
	Orifice Main Burner, #32	9425-069-009			2
	Orifice Main Burner, #32		9425-069-009		3
	Orifice Main Burner, #30			9425-069-002	4
	LP Kit	9732-102-019	9732-102-021	9732-102-022	1
	Overlay-Trim Lower door	9435-016-004	9435-016-005	9435-016-005	1

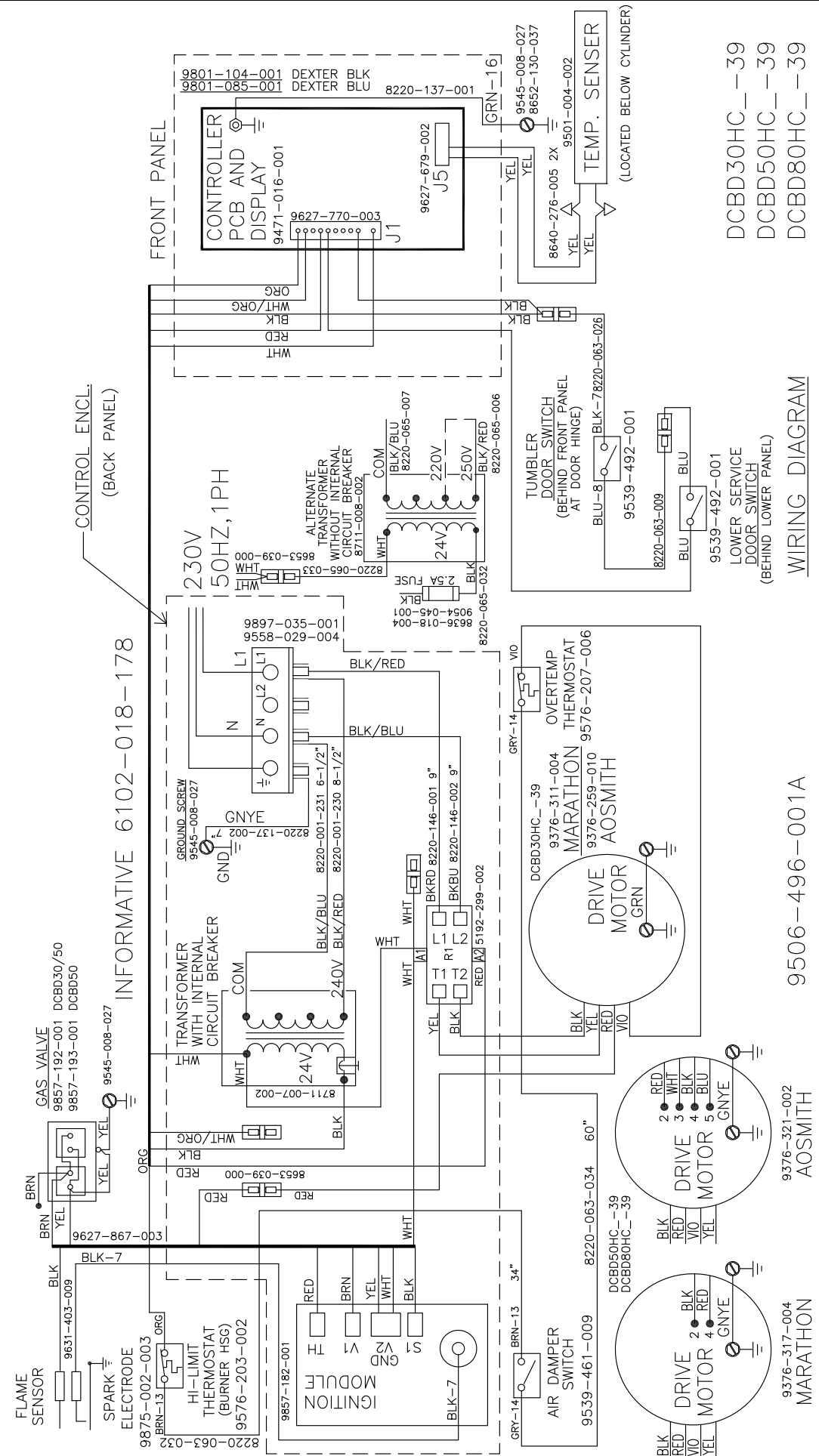

DCBD30HC\_-39  
DCBD50HC\_-39  
DCBD80HC\_-39

WIRING DIAGRAM

9506-496-001A



