

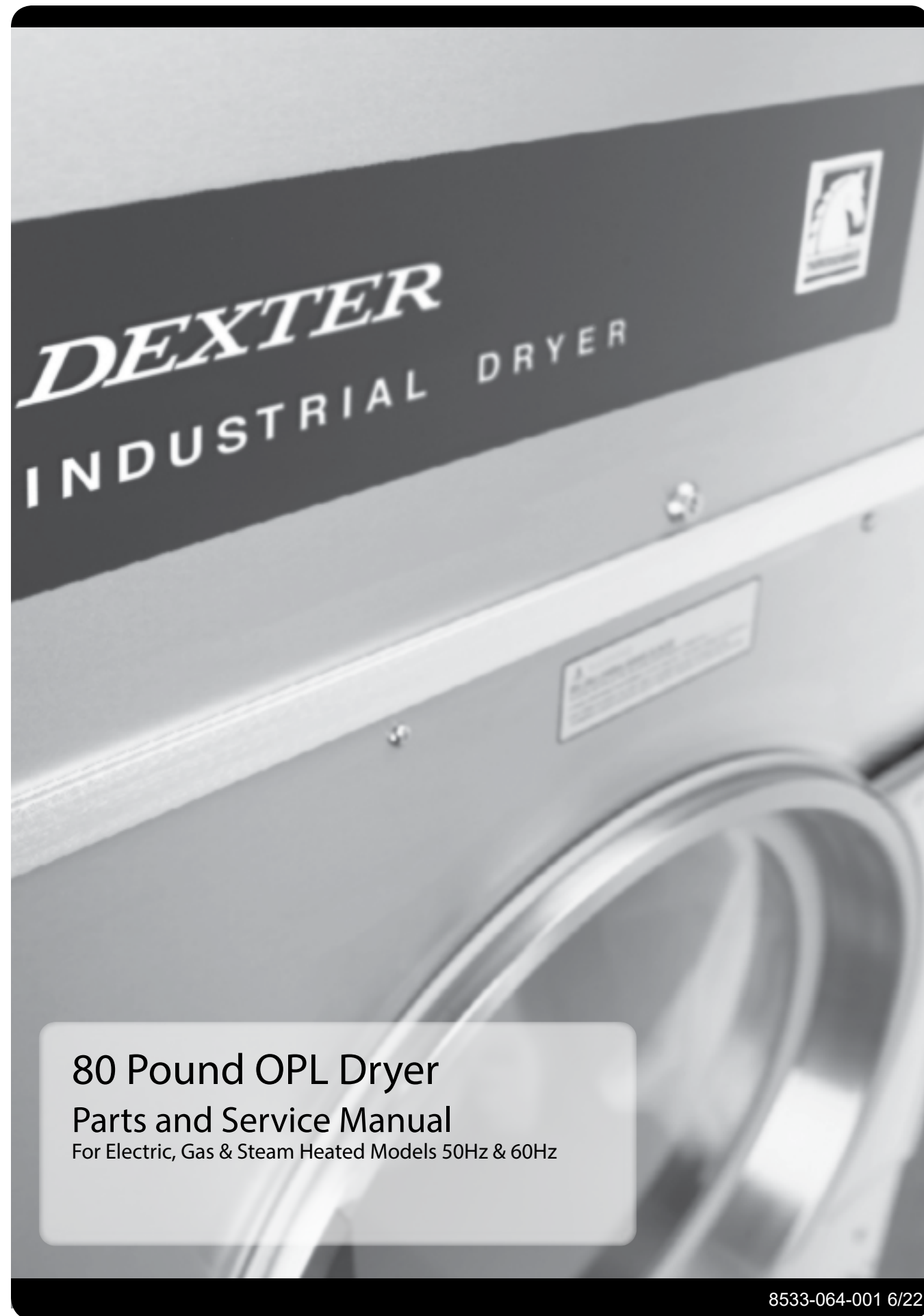

DEXTER[®]
LAUNDRY

**USE THE BLUE TABS LOCATED ON THE
RIGHT AND LEFT SIDES OF THE FOLLOWING
DOCUMENT TO ADVANCE TO EACH SECTION.**



80 Pound OPL Dryer

Parts and Service Manual

For Electric, Gas & Steam Heated Models 50Hz & 60Hz

8533-064-001 6/22

Dexter Safety Guidelines

! WARNING

The dryer must not be stored or installed where it will be exposed to water and/or weather.

For your safety the information in this manual must be followed to minimize the risk of fire or explosion or to prevent property damage, personal injury or death. Do not store or use gasoline or other flammable vapors and liquids in the vicinity of this or any other appliance.

WHAT TO DO IF YOU SMELL GAS

- Do not try to light any appliance.
- Do not touch any electrical switch: do not use any telephone in your building.
- Clear the room, building or area of all occupants.
- Immediately call your gas supplier from a neighbor's telephone.
- Follow the gas supplier's instructions.
- If you cannot reach your gas supplier, call the fire department. Installation and service must be performed by a qualified installer, service agency or the gas supplier.

To activate your warranty, be sure to return your red warranty form to the factory. Please have serial number and model ready when calling for assistance.

You, the purchaser, must post in a prominent location instructions to be followed in the event the user smells gas. Consult your local gas supplier for procedure to be followed if the odor of gas is present.

Post the following "For Your Safety" caution in a prominent location:

FOR YOUR SAFETY

Do not store or use gasoline or other flammable vapors or liquids in the vicinity of this or any other appliance.

THIS MACHINE IS FOR DRYING ONLY FABRICS CLEANED IN WATER.

To avoid possibility of fire, including spontaneous combustion, do not dry oiled floor mops, items containing foam rubber or similarly textured rubberlike materials or any material on which you have used a cleaning solvent or which contains flammable liquids or solids (such as gasoline, kerosene, waxes, etc.)

Specifications for below models
are outlined in this book:

DCWD-80 HC_15	Gas Heat	110-125/208-240/1
DCWD-80 HC_16FE	Electric Heat - 30KW	208/60/3
DCWD-80 HC_16FH	Electric Heat - 35KW	208/60/3
DCWD-80 HC_18FG	Electric Heat - 30KW	240/60/3
DCWD-80 HC_60FS	Steam Heat	208/60/1
DCWD-80 HC_61FS	Steam Heat	240/60/1

Mounting Dimensions

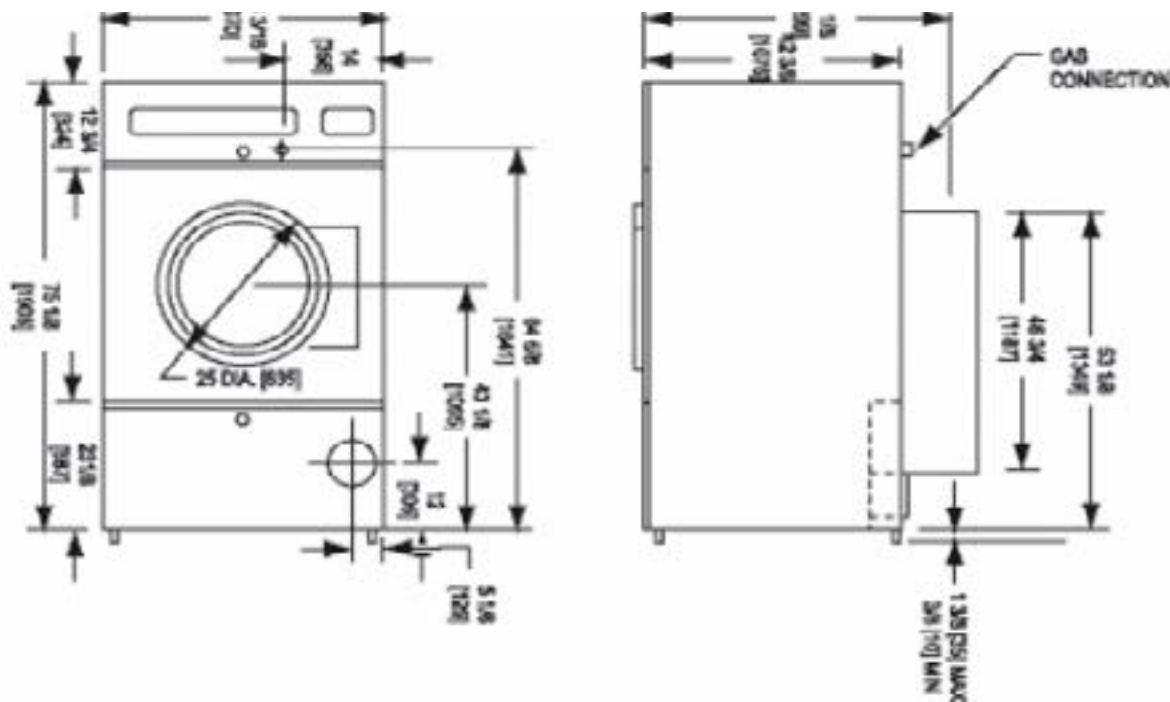

Section 1:
Specifications

Model DCWD80

w/ Microprocessor Control Gas Heat Source

Capacity

Dry Weight Capacity	80 lbs	36.3 kg
Cylinder Diameter	36.5"	92.71 cm
Cylinder Depth	38"	96.52 cm
Cylinder Volume	23 cu. ft.	651.29 dm

Dimensions

Cabinet Height (with feet)-	75.13"	190.82 cm
Cabinet Width	38.44"	97.63 cm
Overall Depth	51.13"	129.86 cm

Electrical

Electrical Voltage (60 Hz)	120V, 208-240V
Electrical Running Amps (60 Hz)	10.8/120V/1 5.2/208-240V/1
Circuit Protection (60 Hz)	15 AMP
Motor Size	1 HP
Service	2 wires + ground
Micro Control	5 pre-programmed formulas

Gas Heat

Gas Input/Hour	215,000 BTU	
Gas Supply Connection (NPT)	1/2"	1.27 mm
Temperature Control	Sensor	

Installation

Air Flow	1200 CFM	
Exhaust Size (Vent Diameter)	8"	20.32 cm
Net Weight	613 lbs	276.12 kg

Section 2: Installation & Operation

Section 2: Uncrating, Installation & Operation

Remove cardboard and innerpack.

Installation

All commercial dryer installations must conform with local applicable local codes or in the absence of local codes, with the National Fuel Gas Code ANSI Z223.1A-1988. Canadian installations must comply with current standard CAN/CGA-B149(.1 or .2) Installation Code for Gas Burning Appliances or Equipment, and local codes if applicable. The appliance, when installed, must be electrically grounded in accordance with the National Electric Code, ANSI/NFPA No. 70-1990, or when installed in Canada, with Standard CSA C22.1 Canadian Electrical Code Part 1.

Installation Clearances

This unit may be installed at the following alcove clearances.

1. Left side 0"
2. Right side 0"

*Units may be installed in direct contact with an adjacent dryer, providing allowance is made for opening upper & lower service doors.

3. Back 18" (certified for 1" clearance; however 18" behind the guard is recommended to clean, service & maintain the dryer)
4. Front 48" to allow use of dryer.
5. Top Certification allows 0" clearance at the top from the front back 1". However, a 1/2" clearance is required to allow opening the upper service door. A 4" clearance is required at the top between 1" & 4" from the front.

A 10" clearance is required from the top at all other points.

6. Floor. This unit may be installed upon a combustible floor.

Make-up Air

Adequate make-up air must be supplied to replace air exhausted by dryers on all types of installations.

Provide a minimum of 1.5 square foot of make-up air opening to the outside for each dryer. This is a net requirement of effective area Screens, grills or louvers which will restrict the flow of air must be considered. Consult the supplier to determine the free area equivalent for the grill being used.

The source of make-up air should be located sufficiently away from the dryers to allow an even air flow to the air intakes of all dryers. Multiple openings should be provided.

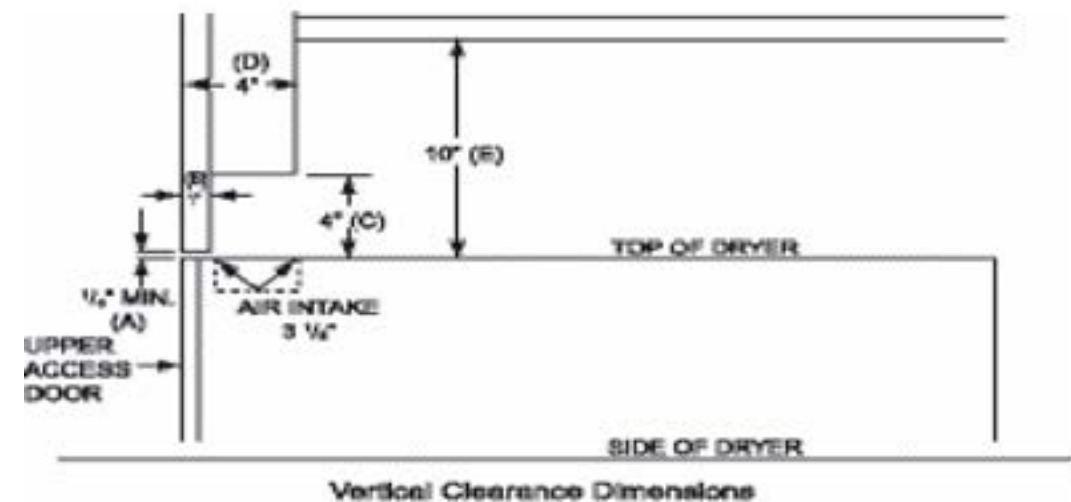

NOTE: The following considerations must be observed for gas dryer installations where dry cleaners are installed. The sources of all make-up air and room ventilation air movement to all dryers must be located away from any dry cleaners. This is necessary so that solvent vapors will not be drawn into the dryer inlet ducts. Dry cleaner solvent vapors will decompose in contact with an open flame such as the gas flame present in clothes dryers. The decomposition products are highly corrosive and will cause damage to the dryer ducts and clothes loads.

ELECTRICAL REQUIREMENTS

240 Volts, 60 Hertz, 1 Phase, 2 Wire Plus Ground
THIS machine was factory wired and tested at this voltage. If hookup to another voltage is required, refer to wiring diagram, schematic and the instructions below.

208 Volts, 60 Hertz, 1 Phase, 2 wire Plus Ground
FOR Connection to a 208 volt, 60 hertz, 1 phase supply, move the wire on the control transformer from the 240 volt terminal to the 208 volt terminal.

120 Volts, 60 Hertz, 1 Phase, 2 Wire Plus Ground
FOR Connection to a 120 volt, 60 hertz, 1 phase supply, move the wire on the control transformer from the 240 volt terminal to the 120 volt terminal. Move the number 3 end of the black jumper wire connecting terminal 3 and 4 on the terminal block so it now connects terminals 2 and 4. Move the number 5 end of the black jumper WIRE connecting terminals 5 and 6 on there terminal block so it now connects terminals 3 and 6.

ELECTRICAL REQUIREMENTS

(REFER to schematic and wiring diagram). Incoming voltage can be 120v or 208-240 volt 1 PH. 60- Hz. The electrical power requirements necessary to operate the unit satisfactorily are listed on the serial plate located on the back panel of each dryer. The ELECTRICAL connection should be made to the terminal in the control box on the rear of the unit, using a wire size adequate to handle the amperage and voltage listed on the serial plate, but never smaller than No. 12 AWG wire. The ground lug must be connected to a good external ground. Individual circuit breakers for each unit are recommended. The schematic and wiring diagram are located on the belt guard on the back of the machine. The voltage is reduced to 24V for operating controls.

GAS REQUIREMENTS

THE Complete gas requirements necessary to operate the dryer satisfactorily are listed on the serial plate located on the back panel of the dryer. The inlet gas connection to the unit is 1/2 inch pipe thread. However, the size of the piping to supply the dryer should be determined by reference to the Fuel Gas Code and consulting the local gas supplier.

A JOint compound resistant to the action of liquefied petroleum gases should be employed in making pipe connections. A 1/8 inch NPT plugged tapping, accessible for test gage connection, must be installed immediately upstream of the gas supply connection to the dryer. A drip tee should be provided in the gas piping supplying the unit to catch dirt and other foreign articles. All pipe connections should be checked for leakage with soap solution or leak detector. Never check with an open flame.

PRESSURE TESTING

THE Dryer and its individual shutoff valve must be disconnected from the gas supply piping

system during any pressure testing of that system at test pressures in excess of 1/2 psig. The dryer must be isolated from the gas supply piping system by closing its individual manual shutoff valve during any pressure testing of the gas supply piping system at test pressures equal to or less than 1/2 psig.

EXHAUST INSTALLATION

AN 8" diameter exhaust connection is required. Exhausting of the dryer should always be planned and constructed so that minimum air restrictions occur. Any restriction due to pipe size or type of installation can cause slow drying time, excessive heat, and lint build up in system and the room.

NOTE: From an operational standpoint, incorrect or inadequate exhausting can cause cycling of the high limit thermostat which shuts off the main burn- ers and results in inefficient drying.

NOTE: Individual exhausting of the dryer is recommended. All heat, mois- ture, and lint should be exhausted outside by attaching a pipe of the proper diameter to the outside by attaching a pipe of the proper diameter to the dryer adapter collars and extending it out through an outside wall. This pipe must be very smooth on the inside, as rough surfaces tend to collect lint which will eventually clog the ducts and prevent the dryer from exhausting properly. All elbows must be smooth on the inside. All joints must be made so the exhaust end of one pipe is inside the next one downstream. The ad- dition of an exhaust pipe tends to reduce the amount of air the blower can exhaust. This does not affect the dryer operation if held within practical lim- its. For the most efficient operation, it is recommended that no more than 20 feet of straight 8" diameter pipe with two right angle elbows be used for each cylinder. When more than two elbows are used, two feet of straight pipe should be removed for each additional elbow. No more than four right angle elbows should be used to exhaust each cylinder.

NOTE: If the exhaust pipe passes through a wall, a metal sleeve of slight- ly larger diameter should be set in the wall and the exhaust pipe passed through this sleeve. This practice is required by some local codes and is rec- ommended in all cases to protect the wall. This type of installation should have a means provided to prevent rain and high winds from entering the exhaust when the dryer is not in use. A hood with a hinged damper can be used for this purpose. Another method would be to point the outlet end of the pipe downward to prevent entrance of wind and rain. In either case, the outlet should be kept clear by at least 24" of any objects which would cause air restrictions.

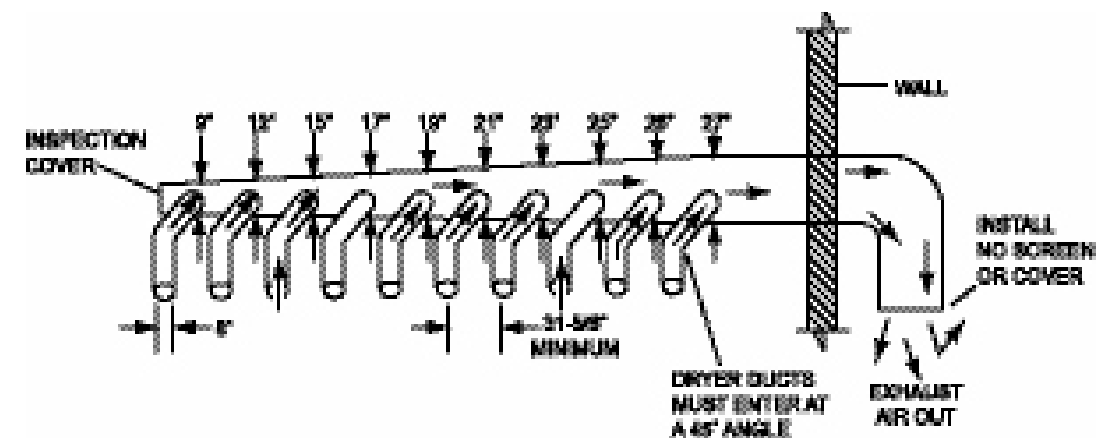

NOTE: Never install a protective screen over the exhaust outlet.

NOTE: When exhausting a dryer straight up through a roof, the overall length of the duct has the same limits as exhausting through a wall. A rain cap must be placed on top of the exhaust and must be of such a type as to be free from clogging. The type using a cone shaped "roof" over the pipe is suitable for this application.

NOTE: Exhausting the dryer into a chimney or under a building is not permitted. In either case there is a danger of lint build-up which can be highly combustible.

NOTE: Installation of several dryers where a main discharge duct is necessary, will need the following considerations for installation. Entrance into the main discharge duct should be at a 45 degree angle in the direction of discharge air flow.

NOTE: Never install the 8" ducts at a right angle into the main discharge duct. The following illustration shows the various round main duct diameters to use with the individual dryer ducts. The main duct can be rectangular or round, provided adequate air flow is maintained. For each dryer the total exhausting (main discharge duct plus duct outlet from the dryer) should not exceed the equivalent of 20 feet and two elbows. The diameter of the main discharge duct at the last dryer must be maintained to exhaust end.

NOTE: A small diameter duct will restrict air flow, a large diameter duct will reduce air velocity, both contributing to lint build up, An inspection door should be provided for periodic clean-out of the main duct.

Dryer Shutdown

To render the dryer inoperative turn off the main gas shut-off valve and disconnect power to the dryer.

Operating Mode -- Manual Dry Cycle

Place the clothes load to be dried in the cylinder and close the dryer door. The clothes should be well separated. Untangling following washing may be necessary for proper drying. Enter the amount of drying time using the numbers. The Manual LED will light. Push the Start button.

When a cycle is running, the display will show the number of minutes that remain in the cycle. The dryer will switch to the Cool Down mode when the Manual Dry cycle is finished. The drying time depends on the size of the load, the type of clothes, the amount of water in the clothes, the room temperature and humidity. At the end of the Cool Down, the dryer will stop and the display will flash DONE.

If the clothes load is not removed, the dryer will automatically tumble every two minutes for twenty seconds to start. After twelve minutes, the time between tumbles is extended to ten minutes. The Wrinkle Free mode stops when the door is opened or the Clear button is pressed.

CAUTION: Damage can occur if any fabric, including 100% cotton is run for an extended period of time on a hot after the clothes are dry.

IMPORTANT: Clothes should be removed as soon as possible after the cycle is completed and the dryer is shut off, to prevent any excessive wrinkling.

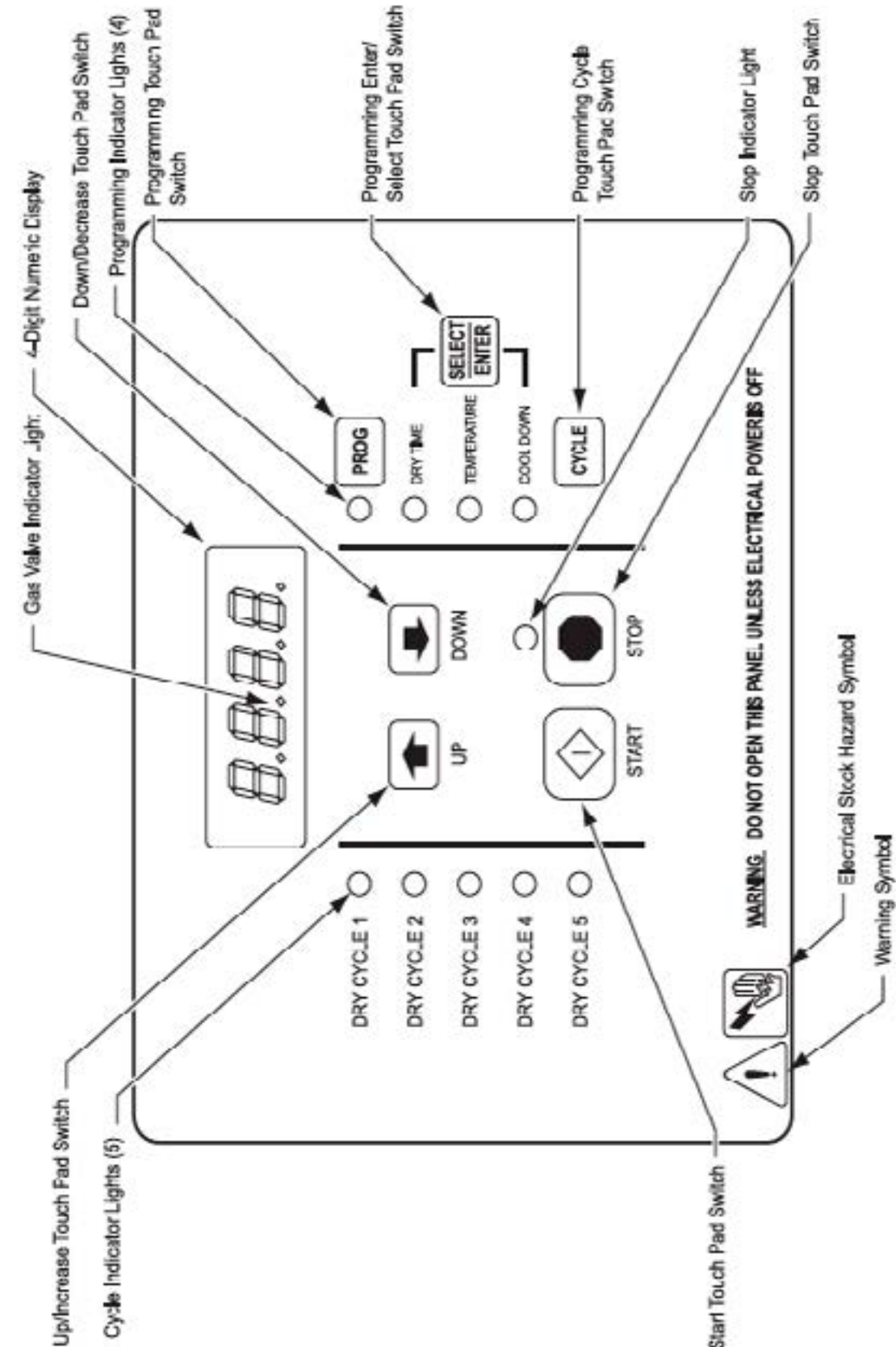

Figure 3: Non-Reversing Dryer Controller Interface

Dryer Controller Factory Default Program Settings

Dry Cycle	Cool Down Time (Minutes)	Total Cycle Time (Minutes)	Drying Temp (F)	Drying Temp (C)	Dryer Load
1	5	35	180	82	Towels, pads, heavy cotton
2	2	20	170	77	Sheets, blended materials
3	5	25	180	82	Cotton
4	2	20	130	54	Synthetic materials
5	2	25	175	79	Blended materials

MICRO PCB adjustments at rear of PCB

There are two jumpers and one push button on the component side of the dryer controller printed circuit board. The jumper located roughly in the lower right side of the circuit board controls whether the controller display shows and operates in the Fahrenheit or Celsius mode. This jumper is labeled as TEMP SELECT and has three pins. The bottom and middle pins are for Celsius and the top and middle pins are for Fahrenheit, which is indicated by the letter C for Celsius and the letter F for Fahrenheit. The other jumper, located in the top middle of the right side of the component side of the dryer controller circuit board, is used for choosing either a reversing or non-reversing type of dryer. This jumper is labeled as REV and NON-REV. This jumper must be in the reversing position, which are the top and middle pins. If the jumper is in the non-reversing position, the dryer will not reverse direction.

CaUTION: If your dryer is made non-reversing it will not reverse the drum by moving the jumper.

The push button, which is located in the middle of the component side of the dryer controller circuit board, is used to reset all five of the dry cycles to the factory default settings. It is labeled as DEFAULT. Even the dry cycles that have been modified using the permanent programming procedure will be changed back to the factory default settings when using this push button. This push button must be pressed and held for at least three seconds with power applied to the dryer controller circuit board.

Touch Pad Description

Indicator Lights (LEDs)

Cycle	These L.E.D.s are on solid when a particular cycle is chosen for operation (1 through 5) or programming.
Gas Valve	This L.E.D. is part of the 4-digit numeric display and will be on solid during the drying part of a cycle when the gas valve does not need to be on. The L.E.D. will be blinking when the gas valve needs to be on. The L.E.D. will not be on solid or blinking (off) if the cycle is stopped, complete, in cool down, or terminated.
Programming	These L.E.D.s are on solid as they are selected during the programming of the dryer controller.
Stop	This L.E.D. is on solid when either the STOP button is pressed once or the door is opened during an operating cycle.

Switches (Push-Buttons)

Up/Increase	This touch pad switch will increment (increase) dry time, cool down time, and drying temperature. It will also scroll upwards when selecting a dry cycle.
Down/Decrease	This touch pad switch will decrement (decrease) dry time, cool down time and drying temperature. It will also scroll down when selecting a dry cycle.
Program	This touch pad switch allows the dryer controller to enter the permanent programming mode.
Select/Enter	This touch pad switch will select one of the three variable parts of the dry cycle (dry time, temperature, or cool down) by sequencing through them. Once one of the variable parts of the dry cycle is chosen and changed, this touch pad switch will enter the new value into the dry cycle program.
Cycle	This touch pad switch allows the dryer controller to enter the temporary programming mode.
Stop	This touch pad switch will stop the dryer during a dry cycle without clearing the present drying cycle if pressed once. If pressed and released twice, consecutively, the present dry cycle will be cleared.
Start	This touch pad switch will start the operation of a dry cycle if pressed and released once. Pressing and holding this touch pad switch will display the current temperature of the dryer heat sensor as long as it is held in the depressed position.

4-Digit Numerical Display Messages

LOAD	This message is displayed after a dry cycle is complete and the dryer loading door has been opened or the STOP touch pad key on the dryer controller has been pressed and released twice.
donE	This message blinks immediately after completion of the dry cycle and continues to blink until the stop key on the dryer controller touch pad is pressed or the dryer loading door is opened.
Prog	This message is displayed when entering the permanent programming mode.
.15	This message appears while the dryer is in the heating time of a dry cycle. The decimal point will blink if the output for the gas valve is on, or remain on constantly if the output for the gas valve is not on. The number represents the total time left in the dry cycle (includes cool down time).
C02	This message appears when the cool down time of the dry cycle is reached. The letter "C" represents the cool down (non-heating) part of the dry cycle. The number(s) after the letter "C" represent(s) the total time remaining in the dry cycle.
F5	This message appears if there is a dryer fault. The letter "F" indicates a fault and the number after the "F" represents the specific fault that has occurred. There are five different faults that can appear (F1 through F5).

Dryer Fault Codes

Fault Code	Fault Description	Action
F1	Shorted Thermostat Sensor	Dryer stops and "F1" flashes on the 4-digit display. When short circuit on sensor input is removed, "LOAD" appears on the 4-digit display and the remaining dry time is reset.
F2	Open Thermostat Sensor	Dryer stops and "F2" flashes on the 4-digit display. When a good sensor is connected to sensor input, "LOAD" appears on the 4-digit display and the remaining dry time is reset.
F3	EEPROM Corrupted	Dryer will not start and "F3" appears on the 4-digit display. The power to the dryer must be cycled to reset the controller. Fault should only occur when starting a dry cycle.
F4	Gas Valve on fault	The drying temperature did not increase 10F. in 5 minutes. "F4" will flash on the display and the dry cycle will finish without calling for heat (energizing gas valve). Opening the door or pressing the STOP key will reset the fault and clear the remaining time in the dry cycle.
F5	Temperature Fault	The drying temperature is at least 25OF. above the temperature setting. "F5" will flash on the 4-digit display and the dry cycle will finish without calling for heat (energizing the gas valve). The power to the dryer must be cycled to reset the controller.

Operating Instructions

To dry a load of items, you must choose one of the five-programmed dry cycles. Each of these five dry cycles may be modified in two different ways to match your load. Please refer to the "Permanent Dryer Controller Programming" or "Temporary Dryer Controller Programming" section of this manual.

There are two parts to each dry cycle. The first part is the heating time, which is when the gas valve is cycled on and off according to the temperature setting in the dry cycle program. The second part is the cool down time, which is after the heating part of the dry cycle, and is when the cylinder continues to turn, but no heat is applied. There will always be at least two minutes of cool down time for each dry cycle. The maximum amount of cool down time is 15 minutes.

The five default dry cycle values are shown in the "DRYER CONTROLLER FACTORY DEFAULT PROGRAM SETTINGS" table in this manual. To improve the drying capabilities of this dryer, you should always separate (untangle) the individual articles in your load before using the dryer.

In the following instruction steps, things that are displayed on the 4-digit numerical display will be in "quotation marks" and any keys on the dryer controller touch pad that physically need to be pressed will be in CAPITAL AND BOLD LETTERS.

STEP 1: Place your untangled load into the dryer cylinder and close the dryer loading door. Notice that the dryer controller 4-digit numerical display should show the word "LOAD". If it does not show this word, then press and release the STOP touch pad key on the dryer controller twice.

STEP 2: Press and release the UP or DOWN arrow touch pad key on the dryer controller to select a dry cycle.

STEP 3: Once the desired dry cycle is selected, press and release the START touch pad key.

After the dryer controller START touch pad key is pressed, the dryer cylinder will start rotating and the two-digit total dry cycle time, along with a decimal point, will appear on the dryer controller display.

The time shown on the dryer controller display will count down to the programmed cool down time. At that time, the display will change from the decimal point and two-digit number to a letter "C" and two digits.

The letter "C" represents the cool down portion of the dry cycle. The two digits represent the amount of time remaining in the dry cycle. The two-digit time, shown on the dryer controller display, will count down to zero.

When the time decrements to zero, the dryer controller display will flash the word "donE" and the end of cycle tone will sound.

At that point, the wrinkle free cycle will automatically begin. This cycle will wait two minutes, if the door is not opened or the STOP touch pad key on the dryer controller is not pressed, and then rotate the cylinder for 10 seconds and stop. This two minutes of idle time and 10 seconds of tumble time will repeat a total of 10 times, at which time the wrinkle free cycle stops. The cylinder will not rotate again until a new dry cycle is started.

During the wrinkle free cycle the gas valve will not be operated and there will be no heat applied to the load. The word "donE" will also continue to flash and do so even after the wrinkle free cycle is finished. When the dryer loading door is opened, or the STOP touch pad key is pressed, the word "donE" will change to the word "LOAD" on the dryer controller display. The dryer will then be ready for another dry cycle.

During the dry cycle, either pressing the STOP touch pad key on the dryer controller or opening the dryer loading door, will stop the dry cycle and not clear it. If you press the STOP touch pad key on the controller and then open the dryer loading door the dry cycle will not be cleared. However, if you open (or open and close) the dryer loading door and then press the STOP touch pad key on the dryer controller, the present dry cycle will be cleared and the word "LOAD" will appear on the dryer controller display.

There are two jumpers and one push button on the component side of the dryer controller printed circuit board.

THE Jumper located roughly in the middle of the circuit board controls whether the controller display shows and operates in the Fahrenheit or Celsius mode. This jumper is labeled as TEMP SELECT and has three pins. The top and middle pins are for Celsius and the bottom and middle pins are for Fahrenheit, which is indicated by the letter C for Celsius and the letter F for Fahrenheit.

THE Other jumper, located in the middle of the right side of the component side of the dryer controller circuit board, is used for choosing either a reversing or non-reversing type of dryer. This jumper is labeled as REV and NON-REV. This jumper must be in the non-reversing position, which are the bottom and middle pins. If the jumper is in the reversing position, the heating part of the dry cycle will not operate properly. The dryer will not reverse direction either.

THE Push button, which is located in the upper right side of the component side of the dryer controller circuit board, is used to reset all five of the dry cycles to the factory default settings. It is labeled as DEFAULT SETTINGS. Even the dry cycles that have been modified using the permanent programming procedure will be changed back to the factory default settings when using this push button. This push button must be pressed and held for at least three seconds with power applied to the dryer controller circuit board.

TEMPORARY DRYER CONTROLLER PROGRAMMING

THE Temporary programming mode will allow the change of the stored dry cycle settings in the dryer controller for one complete dry cycle. After the dry cycle is complete, the default settings that existed before the temporary change are restored. The temporary dry cycle can be stopped and cleared at any time during the dry cycle operation.

TO TEMPorarily change a dryer controller cycle, follow the procedures below. Things that are displayed on the 4-digit numeric display will be in "quotation marks". Keys on the dryer controller touch pad that physically need to be pressed will be in CAPITAL AND BOLD LETTERS.

IF, At any time, you want to escape the temporary programming mode while changing the program settings, you can press the STOP key on the dryer controller touch pad if the 4-digit numeric display is not flashing. The SELECT/ENTER key on the dryer controller touch pad can be pressed and released to enter the flashing value shown on the 4-digit numeric display and allow you to escape.

IF YOU press and release the STOP key on the dryer controller touch pad, when the 4-digit numeric display is not flashing, the temporary changes to the dry cycle program will be cancelled. The stored dry cycle settings that existed before the temporary change will then be restored.

IF, At any time, you want to start the temporary dry cycle during the temporary programming mode, press and release the START key on the dryer controller touch pad if the 4-digit numeric display is not flashing. The SELECT/ENTER key on the dryer controller touch pad can be pressed and released to enter the flashing value shown on the 4-digit numeric display and allow you to start the temporary dry cycle. If

YOU Start the temporary dry cycle, the 4-digit numerical display will change to the total dry time and count down to 0 as the dry cycle progresses.

PROCEDURE

- 1) **MA**ke sure the dryer is not in a dry cycle. The 4-digit numeric display on the dryer controller will show "LOAD" when the dryer is not in a dry cycle.
- 2) **PR**ess and release the UP or DOWN arrow keys on the dryer controller touch pad to choose the dry cycle that you want to change (dry cycle 1 through 5). The dry cycle L.E.D. will illuminate to indicate which dry cycle you are choosing. If you press either arrow key and hold it down, the controller will sequence through the five dry cycles.
- 3) **PR**ess and release the CYCLE key on the dryer controller touch pad once you have chosen the dry cycle you want to change. After you press this key, the programming L.E.D. and the dry time L.E.D. will illuminate. The dry cycle L.E.D. will remain illuminated. The total dry time will also be displayed on the 4-digit numeric display.
- 4) **PR**ess and release the UP or DOWN arrow keys to change the total cycle time. Once either of the arrow keys is pressed, the dry time L.E.D. and the total dry time on the 4-digit numeric display will flash. If you press and hold either arrow key down, you will increment (UP arrow) or decrement (DOWN arrow) through the total dry times available (1 through 60 minutes). This displayed dry time includes the cool down time along with the heated time. To not change the total dry time, do not press the arrow keys to change the total dry time.
- 5) **PR**ess and release the SELECT/ENTER key. Once this key is pressed and released, the dry time L.E.D. will switch off, the dry cycle L.E.D. and programming L.E.D. will remain on, and the temperature L.E.D. will illuminate. The drying temperature will also be shown on the 4-digit numeric display.
- 6) **PR**ess and release the UP or DOWN arrow keys to change the drying temperature. Each press and release of the arrow keys will either increase or decrease the temperature by five degrees Fahrenheit or three degrees Celsius, depending on how your dryer controller is set up. Once either of the arrow keys is pressed, the temperature L.E.D. and the drying temperature on the 4-DIGit numeric display will flash. If you press and hold either arrow key down, you will increment (UP arrow) or decrement (DOWN arrow) your way through the available drying temperatures (1050 Fahrenheit or 410 Celsius, up to 1950 Fahrenheit or 900 Celsius). If you do not want to change the drying temperature, do not press the arrow keys. Go to the next step.
- 7) **PR**ess and release the SELECT/ENTER key. Once this key is pressed and released, the temperature L.E.D. will switch off, the dry cycle L.E.D. and programming L.E.D. will remain on, and the cool down L.E.D. will illuminate. The cool down time will also be shown on the 4-digit numeric display.
- 8) **PR**ess and release the UP or DOWN arrow keys to change the cool down time. Once either of the arrow keys is pressed, the cool down L.E.D. and the cool down time on the 4-digit numeric display will flash. If you press and hold either arrow key down, you will increment (UP arrow) or decrement (DOWN arrow) through the cool down times available (2 through 15 minutes). To not change the cool down time, do not press the arrow keys. Go to the next step.
- 9) **PR**ess and release the SELECT/ENTER key. Once this key is pressed and released, the cool down L.E.D. and the programming L.E.D. will switch off, and the dry cycle L.E.D. will remain on. The flashing cool down time on the 4-digit display will stop flashing and remain.

10) At this point, you have two choices. 1) You can perform the modified dry cycle by pressing and releasing the START key on the dryer controller touch pad, or 2) You can clear the modified dry cycle program by pressing and releasing the STOP key once. If you start the modified cycle, the total dry time will appear on the 4-digit numeric display and it will count down to 0 as the dry cycle progresses. If you choose to clear the modified dry cycle, the 4-digit numeric display will change to "LOAD".

TEMPORARY DRYER CONTROLLER PROGRAMMING EXAMPLE

REQUIREMENTS: Dry a load with 40 minutes of actual heat at 185 0F and five minutes of cool down.

THE Following procedure will show you how to temporarily modify the existing dry cycle 1 program for one cycle of drying. It is based on the assumption that the factory defaults have not been permanently

CHANGED. If they have been changed, the steps of this procedure will be the same, but the values that are displayed will be different. The amount of times that the dryer controller touch pad UP or DOWN keys must be pressed and released may also be different.

IF YOU want the change to be permanent, go to the "PERMANENT DRYER CONTROLLER PROGRAMMING" section of this manual.

PROCEDURE:

- 1) AFter the load has been placed in the dryer, press and release the UP or DOWN touch pad key on the dryer controller until the L.E.D. for dry cycle 1 is illuminated.
- 2) PRes and release the CYCLE key on the dryer controller touch pad. You will see the number "35" on the dryer controller display. The programming L.E.D. and dry time L.E.D. will be illuminated.
- 3) PRes and release the UP arrow key on the dryer controller touch pad 10 times so the display will show a flashing "45". When the UP arrow touch pad key is pressed the first time, the number "36" will be flashing on the dryer controller display. Each number after that will also flash.
- 4) NOw, press and release the SELECT/ENTER touch pad key on the dryer controller. The number "45" will stop flashing and the dry time L.E.D. will switch off. The dryer controller display will now show "180", the temperature L.E.D. will illuminate, and the programming L.E.D. and dry cycle 1 L.E.D. will remain on.
- 5) PRes and release the UP arrow key on the dryer controller touch pad one time so the controller display will show a flashing "185". Each press of the UP arrow key will increment the temperature by five degrees.
- 6) NOw, press and release the SELECT/ENTER touch pad key on the dryer controller. The number "185" will stop flashing and the temperature L.E.D. will switch off. The dryer control display will now show a number "5", the cool down L.E.D. will illuminate, and the programming L.E.D. and dry cycle 1 L.E.D. will remain on.
- 7) PRes and release the SELECT/ENTER key on the dryer controller touch pad, since the desired cool down time is five minutes. After you press the SELECT/ENTER touch pad key on the controller, the cool down L.E.D. and programming L.E.D. will switch off. The controller display will remain at "5" and the cycle 1 L.E.D. will remain on.

YOU Are now ready to start the new dry cycle. This new dry cycle will be in effect for one dry cycle only. After the dry cycle is done, or if the STOP touch pad key on the dryer controller is pressed and released twice, consecutively, the cycle 1 program will revert to the factory default settings.

IF YOU press the START touch pad key on the dryer controller, the controller display will change from the number "5" to the number "45" and dry cycle 1 will begin.

PERMANENT Dryer Controller Programming

THE Permanent programming mode will allow the change of the stored dry cycle settings in the dryer controller until the operator physically changes them again. The factory default settings can be restored in the dryer controller by pressing the default settings pushbutton on the back

(COMPOnent) side of the dryer controller circuit board. It is labeled and located on the upper right side of the printed circuit board, as you face the component side of the board. It must be pressed and held down for at least three seconds.

TO PERmanently change a dryer controller cycle, follow the procedure below. Things that are displayed on the 4-digit numeric display will be in "quotation marks". Keys on the touch pad that physically need to be pressed will be in CAPITAL AND BOLD LETTERS.

IF, At any time, you want to escape the permanent programming mode while changing the settings, you can press the STOP key on the dryer controller touch pad if the 4-digit numeric display is not flashing. The SELECT/ENTER key on the dryer controller touch pad can be pressed and released to enter the flashing value shown on the 4-digit numeric display and allow you to escape.

PROCEDURE

- 1) MAke sure the dryer is not in a dry cycle. The 4-digit numeric display on the dryer controller will show "LOAD" when the dryer is not in a dry cycle.
- 2) PRes and release the PROG key on the dryer controller touch pad.
- 3) PRes and release the UP arrow key on the dryer controller touch pad. The programming L.E.D. will illuminate and the 4-digit numeric display on the dryer controller will change to "Prog".
- 4) PRes and release the UP or DOWN arrow keys to choose the dry cycle you want to change (dry cycle 1 through 5). The dry cycle L.E.D. will illuminate to indicate which dry cycle you are CHOOSing. If you press either arrow key and hold it down, the controller will sequence through the five dry cycles.
- 5) PRes and release the SELECT/ENTER key once you have chosen the dry cycle you want to change. After you press this key, the dry time L.E.D. will illuminate. The dry cycle L.E.D. and the programming L.E.D. will remain illuminated. The total dry time will also be displayed on the 4-digit numeric display.
- 6) PRes and release the UP or DOWN arrow keys to change the total dry time. Once either of the arrow keys is pressed, the dry time L.E.D. and the total dry time on the 4-digit numeric display will flash. If you press and hold either arrow key down, you will increment (UP arrow) or decrement (DOWN arrow) through the total dry times available (1 through 60 minutes). This displayed dry time includes the cool down time along with the heated time. To not change the total dry time, do not press the arrow keys. Go to the next step.
- 7) PRes and release the SELECT/ENTER key. Once this key is pressed and released, the dry time L.E.D. will switch off, the dry cycle L.E.D. and programming L.E.D. will remain on, and the temperature L.E.D. will illuminate. The drying temperature will also be shown on the 4-digit numeric display.
- 8) PRes and release the UP or DOWN arrow keys to change the drying temperature. Each press and release of the arrow keys will either increase or decrease the temperature by five degrees Fahrenheit or three degrees Celsius, depending on how your dryer controller is set up. Once either of the arrow keys is pressed, the temperature L.E.D. and the drying temperature on the 4-digit numeric display will flash. If you press and hold either arrow key down, you will increment (UP arrow) or decrement (DOWN arrow) your way through the available drying temperatures (1050 Fahrenheit or 410 Celsius, up to 1950 Fahrenheit or 900 Celsius). If you do not want to change the drying temperature, do not press the arrow keys. Go to the next step.

9) Press and release the SELECT/ENTER key. Once this key is pressed and released, the temperature L.E.D. will switch off, the dry cycle L.E.D. and programming L.E.D. will remain on, and the cool down L.E.D. will illuminate. The cool down time will also be shown on the 4-digit numeric display.

10) Press and release the UP or DOWN arrow keys to change the cool down time. Once either of the arrow keys is pressed, the cool down L.E.D. and the cool down time on the 4-digit numeric display will flash. If you press and hold either arrow key down, you will increment (UP arrow) or decrement (DOWN arrow) through the cool down times available (2 through 15 minutes). To not change the cool down time, do not press the arrow keys. Go to the next step.

11) Press and release the SELECT/ENTER key. Once this key is pressed and released, the cool down L.E.D. will switch off, the dry cycle L.E.D. and programming L.E.D. will remain on, and the 4-digit numeric display will change to "Prog".

12) Press and release the STOP key to save the cycle program and escape the programming mode. If you want to change the same dry cycle program again, press the SELECT/ENTER key and continue at step 6 of this procedure. If you want to modify another dry cycle program, go to step 4 of this procedure and continue.

13) If you pressed the STOP key to escape the programming mode, you may now start the dry cycle by pressing the START key.

Permanent Dryer Controller Programming Example

REQUIREMENTS: Dry a load with 50 minutes of actual heat at 195 o F and three minutes of cool down. The following procedure will show you how to permanently modify the existing dry cycle 1 program for one cycle of drying. It is based on the assumption that the factory defaults have not been permanently changed. If they have been changed, the steps of this procedure will be the same, but the values that are displayed will be different. The amount of times that the dryer controller touch pad UP or DOWN keys must be pressed and released may also be different. If you want the change to be temporary (for only one dry cycle), go to the "TEMPORARY DRYER CONTROLLER PROGRAMMING" section of this manual.

PROCEDURE:

1) After the load has been placed in the dryer, press and release the UP or DOWN touch pad key on the dryer controller until the L.E.D. for dry cycle 1 is illuminated.

2) Press and release the PROG touch pad key on the dryer controller. The dryer controller display will not change.

3) Immediately, press and release the UP arrow key on the dryer controller touch pad. The controller display will change from "LOAd" to "Prog". You have now entered the permanent programming mode. The dry time L.E.D. will remain on and the programming L.E.D. will illuminate.

4) Press and release the SELECT/ENTER touch pad key once. The dry time L.E.D. and programming L.E.D. will remain on and the dry time L.E.D. will illuminate. The dryer controller will also show the number "35".

5) Press the UP arrow touch pad key 18 times until the dryer controller display shows the number "53".

6) Press and release the SELECT/ENTER touch pad key once. The dry time L.E.D. and programming L.E.D. will remain on and the dry time L.E.D. will switch off. The temperature L.E.D. will illuminate and the dryer controller display will show the number "180".

7) Press and release the UP arrow touch pad key three times until the dryer controller display shows the number "195".

8) Press and release the SELECT/ENTER touch pad key. The dry time L.E.D. and the programming L.E.D. will remain on and the temperature L.E.D. will switch off. The cool down L.E.D. will illuminate and the dryer controller display will show the number "5".

9) Press and release the DOWN arrow touch pad key twice until the dryer controller display shows the number "3".

10) Press and release the SELECT/ENTER touch pad key. The dry time L.E.D. and the programming L.E.D. will remain on and the cool down L.E.D. will switch off. The dryer controller display will change to "Prog".

11) Press and release the STOP touch pad key. The dry time L.E.D. will remain on and the programming L.E.D. will switch off. The dryer controller display will change to the word "LOAd".

The dryer is now ready for the new modified dry cycle to start. This modified dry cycle 1 program will remain in the dryer controller memory until the default settings push button is pressed. This default settings push button is located on the component side of the dryer controller printed circuit board in the upper right corner.

Heat Circuit

The control transformer uses the incoming voltage (208-240v or 110-125v) on the primary side and steps it down to 24 volts on the secondary side of the transformer. The 24 volts is then sent through a 1.5 amp fuse on one side of the transformer and supplies power to the computer board on a black wire and 24 volts is also sent to the normally open door switch on a black wire. With the door shut, power is then supplied by the blue wire to the run and gas relay on the computer board. When the START button is pushed on front of computer board it then sends voltage to engage the motor relay which sends power on the violet wire to R1 relay. 24 volts is then sent on a grey wire from the gas relay on the computer board to the manual reset over temp thermostat and through on the black wire then on to the air damper switch and changes to a brown wire and then on to the hi-limit switch where the 24 volts passes through the violet wire and after the drive motor starts, the centrifugal switch inside the motor moves to the run position allowing 24 volts to pass through on the red wire to the spark ignition module. The spark ignition module now sends a high voltage signal to the spark electrode for 10 seconds to light the burner and simultaneously sends 24 volts to the gas valve. When ignition occurs the high voltage spark stops and the gas valve will stay open and burner will continue to burn. If ignition does not occur within 10 seconds, the spark ignition module will try 2 more times with a sequence of 10 seconds of trial and 15 seconds off time and if the burner does not stay burning lock out occurs closing the gas valve and stopping the spark. To reset the spark ignition module, the dryer loading door can be opened or a break in the power and the tumbler allowed to stop and remain stopped for 10 seconds.

Section 3: Wiring Schematics

Wiring Schematic 80 Pound OPL Dryer

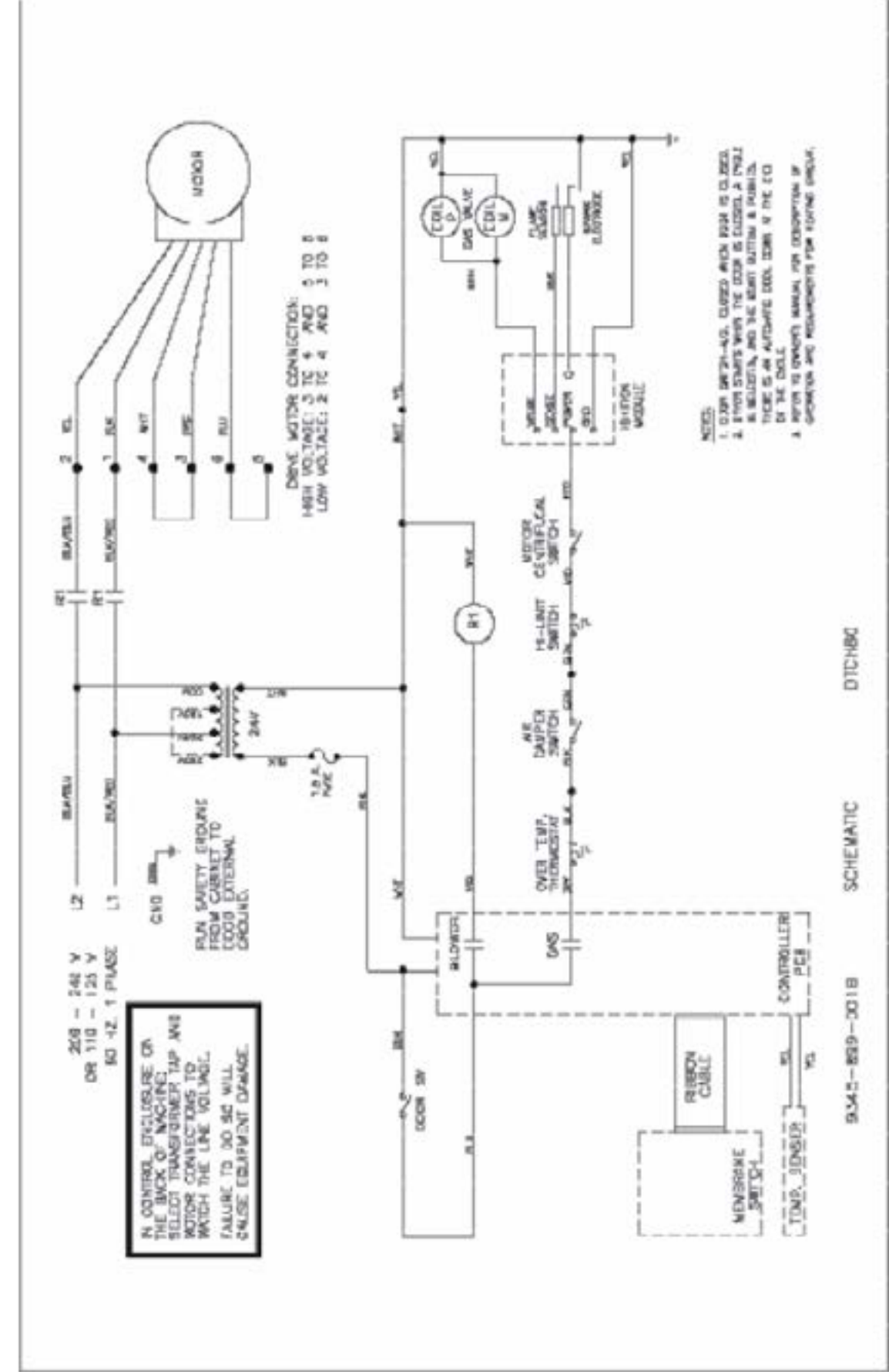

Section 4: Service Procedures

Clothes Door Removal

STEP 1: The clothes door may be removed from the hinge bracket by unscrewing and removing the allen head pivot screw located at the door upper hinge point.

STEP 2: Next lean the door out of the top of the hinge bracket and lift the door from the bottom hinge pin.

Clothes Door Latch Adjustment

STEP 1: Loosen the lock nut on the latching stud. It is located directly behind the door handle.

STEP 2: Open the loading door.

STEP 3: Screw the door catch stud in or out as necessary and then retighten the lock nut.

Installation of Clothes Door Window & Gasket

STEP 1: Remove the loading door.

STEP 2: Place the clothes door, with its face down, on a solid surface.

Note: Pre-warming the gasket under a heat lamp makes the installation much easier.

STEP 3: Put the door glass gasket on the loading door with the ridges in the wide side up. Locate the seam at the door latching stud.

Note: The gasket has one narrow opening on one side and a wide opening on the other. The narrow side mounts to the door. The wide side holds the glass. The wide side has ridges on one interior lip. This ridged side should go up with the door laying face down.

STEP 4: Coat the inside and outside of the gasket with rubber lubricant or liquid soap.

STEP 5: Slide the glass into the middle of the gasket with half of the glass above the door and half below the door.

STEP 6: While pressing on the glass, use a modified screwdriver (grind the end off so that it is round and put a slight bend in it) and run it around half of the glass.

STEP 7: With half of the glass installed, turn the door over and repeat step 6.

STEP 8: Insert the modified screwdriver at the 6 o'clock position and pry the glass up enough to install the door glass support spacer (small diameter rubber tube).

Door Switch Removal & Installation

STEP 1: The door switch is located directly behind the hinge plate of the loading door assembly. Open the door for access to the switch area. Remove the two screws holding the switch cover in position. This will allow the removal of the cover and the switch actuator plate. between the thermostat and bracket which must be used to give proper operation.

STEP 2: The entire switch box can now be pulled from the front panel opening, creating access to the door switch mounting screws.

STEP 3: Remove these two mounting screws and twin nut which frees the door switch and insulating shield. Remove wires.

STEP 4: When installing the door switch make certain the insulating shield is reassembled.

STEP 5: The actuator plate and switch box cover should be assembled as illustrated in the parts section of this book.

Door Switch Operation & Testing

The normally open door switch must be closed (0 ohms resistance) for the motor and heat circuits to operate. When the door is opened, the door switch breaks the 24 volt control circuit.

Door Switch Adjustment

STEP 1: Remove the two switch box cover screws.

STEP 2: Remove the switch cover and actuator plate.

STEP 3: Pull the entire switch box out from the opening in the front panel.

STEP 4: Loosen the bottom door switch mounting screw.

STEP 5: A slotted mounting allows the switch to slide in or out for adjustment.

High Limit Thermostat Locations & Functions

Burner Housing

This hi-limit is located on the left side of the burner housing.

STEP 1: The thermostat opens the circuit to the main burners in the event of malfunction in the gas control area or temperature control. This thermostat will open quickly if there is a significant loss of air flow over the burner area.

STEP 2: It is covered by a guard and is held in place by two screws. There are spacers between the thermostat and bracket which must be used to give proper operation.

Manual Resettable Over Temperature Safety Thermostat

The second hi-limit thermostat is located outside the rear exhaust opening mounted on the exhaust recirculation duct at the rear outlet burner height.

STEP 1: The manually resettable thermostat limits the operating temperature a dryer can reach should some abnormal situation occur.

STEP 2: Should the thermostat be tripped, the dryer will cease to heat until the thermostat is reset. Once the dryer cools, the thermostat may be reset by inserting a pencil or stick through the opening in the thermostat cover and pushing the button in.

REMOVAL: To remove the manual resettable over temperature safety thermostat on the exhaust recirculation duct, remove cover mounting screws holding its respective guard. Next, remove the terminals of each wire attached to the thermostat. Lastly, remove mounting screws holding the thermostat to the recirculation boot.

Pressure Regulator Adjustment

Use the following procedure whenever it is necessary to check the pressure regulator setting. NOTE: Any adjustment of the pressure regulator must be made with a manometer attached at the plug in the main burner manifold.

STEP 1: Shut off the gas supply to the dryer.

STEP 2: Remove the 1/8" pipe plug from the end of the main burner manifold.

STEP 3: Attach a manometer to the manifold end.

STEP 4: Remove the pressure regulator cover screw on the gas valve.

STEP 5: Open the shut-off valve, and operate the dryer.

STEP 6: Adjust the pressure for a manometer reading of 3.5" water column gas pressure. (11.0" for L.P.)

NOTE: The main burners must be operating when adjusting the pressure regulator.

STEP 7: Shut off the gas supply to the dryer. Remove the manometer and install the 1/8" pipe plug in the manifold.

STEP 8: Open the shut off valve, start the dryer and check for gas leaks while the burners are ignited.

Front Panel Removal

To remove the front panel, first remove the loading door from the panel. Then remove the two left side screws and the four right side screws. The trim does not have to be removed. (The panel may be removed with the door left in place, although it is much heavier and more awkward to do so.)

NOTE: Always remove power from the machine before changing drive belts or working with the drive and fan system.

Final Drive Belt Replacement

To replace the final drive belt turn the cylinder slowly by hand and work the belt off of the large pulley.

Motor Drive Belt Replacement

To replace the motor drive belt the final drive belt should be removed as above. Next turn the intermediate drive pulley and work the belt off of it similarly to the above belt.

Blower Impeller Removal

Remove the lint hood that is located inside the lower service door. Take notice of the location of the impeller location on the shaft. Remove the two set screws that hold the motor to the shaft.

Airflow switch removal and adjustment

The air switch assembly is part of the ignition safety circuit and insures that the burner doesn't operate unless there is airflow. If this doesn't happen, ignition will not occur. The air switch assembly is located inside the lint compartment on top of the blower housing.

Electronic Ignition Module

This machine uses an electronic spark ignition system to directly light the burners.

STEP 1: The electronic ignition module (gray box) is located inside the upper access door in the control box.

STEP 2: The red wire from the transformer provides 24 VAC through the 1.5 amp fuse and into the module to operate the entire direct ignition system.

STEP 3: The black colored hi-voltage wire (spark plug type) plugs onto the post connector on the module, and the multi-wire plug fits into the side of the module.

Spark Electrode Assembly-Removal

STEP 1: Remove electrode cover and disconnect wires to electrodes.

STEP 2: Remove two screws to detach electrode assembly.

NOTE: Proper grounding of the ignition system (yellow wires) is very critical for proper ignition sequence

If there is no spark or intermittent spark, check black hi-voltage lead wire for damage or cracks in insulation. *This lead wire must not be taped or connected to any metal edges along its length to prevent pinching and arcing. Also, do not bundle this wire with other wires.*

NOTE: Spark gap and electrode location are important. If the electrode is damaged or mounting is changed the spark gap may not be correct for ignition to occur. Check for cracks in the ceramic insulator. Replace electrode assembly if necessary. Also check for carbon or foreign material on the electrodes and clean if necessary.

Gas Valve & Manifold Removal

STEP 1: Disconnect union at gas valve and disconnect wires from gas valve operator coils.

STEP 2: Remove right manifold mounting bracket screws and slide manifold to remove from left bracket.

Spark Electrode Assembly-Function

1. The spark electrode and sensing electrodes are located directly at the side of the burner housing.
2. The electrode with the black hi-voltage wire conducts the spark to the center grounding probe, directly over the burner.
3. The electrode with the black sensing wire detects ignition and monitors flame by signaling the module.

NOTE: Proper grounding of the ignition system (yellow wires) is very critical for proper ignition sequence.

Ignition System-Function & Sequence

During normal dryer operation, the following occurs:

1. The dryer electronic control calls for heat.
2. From the 24VAC control transformer, voltage for the heat circuit is applied to the control through the door switch. If the control detects that the heat should be on, a circuit is closed providing power through the over-temp thermostat, the air damper switch, the high limit switch and the motor centrifugal switch to the Ignition Module. Once the 24VAC reaches the ignition module on the red wire, sparking occurs at the ignition electrode and 24VAC is applied to open the Gas Valve.
3. Once the flame is established, the sensing electrode detects the presence of flame and the sparking stops.
4. If for any reason the flame is not established in a period of 10 seconds, the electronic control will try this sequence for 3 tries. Normally the 10 seconds "Trial For Ignition" period is ample to establish and prove flame.
5. If the flame is shutdown or blown out during operation, the ignitor will immediately go into "Trial. For Ignition" again for 10 seconds.
6. However, at the end of 3 separate retries of 10 seconds "Trial for Ignition", the flame is not established, the ignition system goes into "Safety Lock-Out" and will not reactivate the "Trial for Ignition" until there is a current interruption for a period of 15 seconds. This interruption can be provided by opening the dryer loading door and allowing the machine to come to a complete stop for 15 seconds.

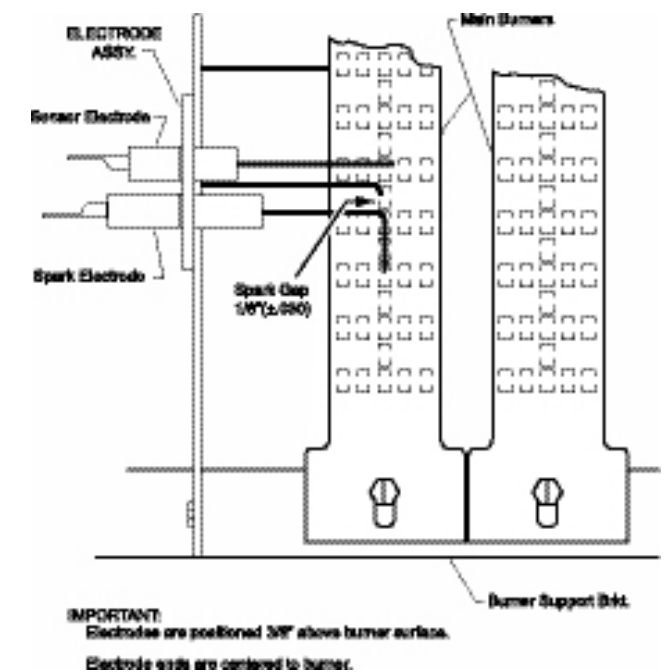

Main Burner Orifice Removal

STEP 1: Remove manifold and gas valve assembly as above.

STEP 2: Using an open end wrench, remove orifices from manifold.

Main Burner Removal

Remove manifold & gas valve assembly as previously discussed. Remove the screw securing the front of the burner to the support bracket. The burner may now be removed.

Cylinder Pulley Removal

Remove nut holding pulley to cylinder shaft. Pull pulley straight off of shaft.

Intermediate Pulley Removal

The intermediate pulley can be removed by removing the snap ring holding the pulley to the tension arms.

Tension Arm Assembly Removal

The tension arm assembly may be removed by removing the snap ring that holds it to the tension arm support assembly pin. If it is necessary the arm assembly is replaced as a complete unit.

Tension Arm Support Assembly Adjustment

The tension arm support assembly may be adjusted for alignment of the intermediate pulley and also to align the belts. The three outer nuts allow the alignment of the pin to be adjusted by pivoting the assembly on the center bolt. The center bolt can be screwed in to allow bringing the complete assembly farther back if necessary for belt alignment.

Cylinder Removal

STEP 1: Remove the front panel in front of the cylinder.

STEP 2: Remove drive belt, nut, pulley, and shaft key.

STEP 3: Pull the cylinder from the front of the machine.

Adjustment of Cylinder Assembly

STEP 1: Loosen the two top adjusting bolts and two bottom adjusting nuts and lock nuts holding the bearing housing to the drive plate.

STEP 2: Loosen the four mounting bolts on the side channels.

STEP 3: Open the clothes door and insert a 1/2" thick shim at the 3 and 9 o'clock positions and a 1/4" thick shim at the 6 o'clock position.

STEP 4: Tighten the two bottom adjusting nuts and tighten locking nuts.

STEP 5: Tighten the bottom right mounting bolt, then the top left mounting bolt. Tighten the remaining two bolts. (Shim where and if necessary.)

STEP 6: Tighten the two top adjusting bolts.

STEP 7: Remove all the shims from between the front panel flange and cylinder (3,6,9 and 12 o'clock).

STEP 8: Spin the cylinder to check for rubbing baffles, pressing down hard while rotating. If rubbing is detected, repeat procedure paying particular attention to placement of shims between bearing housing and side channels.

Bearing Housing Removal

After removing cylinder as previously outlined, simply unbolt the bearing housing and remove.

Section 5: Trouble Shooting

Section 5: Trouble Shooting - Gas Heated

Symptom	Probable Cause	Suggested Remedy
Tumbler does not turn	Drive belts	Check both drive belts
	Drive motor	Check capacitor and motor
	Door switch	Check door switch contacts and adjustment
	Micro control	Check that LED's are lit and green start key pushed
	Motor Relay	Check motor relay coils (24v) and contacts.
Tumbler turns but no spark temperature	Temperature	Check for selected in formula at burner
	Spark Electrode	Check electrode for damage to electrode or mounting
	Temperature Sensor	Check by plugging in good sensor
	Ignition Transformer	Check for 24 V out of transformer to ignition control
	Ignition control Air flow switch	Try another control Check for circuit through air flow switch
	Hi-limit	Check hi-limit
	Over-temp	Check by inserting pencil eraser side thru (Manual Reset) hole and push to reset
	Gas supply	No gas can cause system lockout check for W.C.

Symptom	Probable Cause	Suggested Remedy
Tumbler turns ignition sparks no flame	Gas supply	Make sure gas supply is working
	Gas pressure	Make manometer check of gas pressure for 3.5"W.C. natural 11"W.C. propane
	Spark electrode	Check electrode for damage to electrode or mounting
	Gas valve	Check coil continuity, replace valve if bad
Slow drying	Thermostat	What is temperature set at on control
	Air flow Restrictions	Follow installation guidelines for static back pressure and make up air
	Lint screen	Clean screen
	Exhaust	Check complete exhaust system for excessive back pressure in the duct work. No more than .3 static pressure
	Makeup air	Check for adequate makeup air (1.25 sq. Ft.)
	Temp sensor	Clean or replace sensor if necessary
	Gas	Gas pressure at burner should be (3.5" W.C.) while burning
	Blower Impeller	Check impeller for operation and check mounting set screw
	Steam & Electric Heated	Check relay for activation. Check steam Check steam valve for steam trough

Dryer Fault Codes

FAULT#	FAULT DESCRIPTION	ACTION
F1	Shorted thermostat sensor	Dryer stops and "F1" flashes on the 4- digit display. When short circuit on sensor input is removed, "LOAD" appears on the 4-digit display and the remaining dry time is reset.
F2	Open thermostat sensor	Dryer stops and "F2" flashes on the 4-digit display. When a good sensor is connected to sensor input, "LOAD" appears on the 4-digit display and the remaining dry time is reset.
F3	EEPROM corrupted.	Dryer will not start and "F3" appears on the 4-digit display. The power to the dryer must be cycled to reset the controller. Fault should only occur when starting a dry cycle.
F4	Gas valve on fault.	The drying temperature did not increase 1°F. in 5 minutes. "F4" will flash on the display and the dry cycle will finish without calling for heat (energizing gas valve). Opening the door or pressing the STOP key will reset the fault and clear the remaining time in the dry cycle.
F5	Temperature fault.	The drying temperature is at least 25°F. above the temperature setting. "F5" will flash on the 4-digit display and the dry cycle will finish without calling for heat (energizing the gas valve). The power to the dryer must be cycled to reset the controller.

Kits, Assemblies, & Common Parts

Loading Door Components	Part Number
Door Handle	9244-082-001
Door Close Switch	9539-461-001
Electrical Components	Part Number
Transformer, Control	8711-007-001
Controls	9732-249-001
Heating Circuit Components	Part Number
Ignition Control Module	9857-116-003
Ignition Electrode Assembly	9875-002-003
Thermostat, Hi-Limit	9576-203-002
Thermostat, Overtemp	9576-207-006
Fuseholder	9200-001-002
Fuse 1.5 amp	8636-018-001
Airflow Switch	9539-461-009
Cabinet Components	Part Number
Cleanout Duct Assembly 8"	9973-034-001

Section 6: Parts Data

Cabinet Group

Key	Part Number	Description	Qty
*	9960-285-005	Door Assy., Loading Complete-Wht	1
*	9960-285-004	Door Assy., Loading Complete-SS	1
1	9960-284-002	Door Assy.ONLY, Loading-SS	1
2	9982-360-003	Plate Assy., Hinge (Wht)	1
2	9982-360-001	Plate Assy., Hinge (SS)	1
*	9545-012-015	Screw, Hinge to Door 10-32 x 3/8"	4
*	8640-413-002	Nut, Hinge to Door #10-32 UNF	4
3	9212-002-004	Glass, Door	1
4	9206-164-010	Gasket, Glass	1
*	9548-117-000	Support, Door Glass (inside gasket)	1
5	9206-420-004	Gasket, Outer Rim	1
6	9244-082-001	Handle, Loading Door	1
*	9545-018-017	Screw, Handle 1/4"-20 x 3/8"	2
*	9531-033-001	Stud, Door Catch	1
*	8640-413-001	Nut, Hex	1
*	8640-413-003	Nut , Acorn # 10-32	1
*	9086-015-002	Catch, Loading Door	1
7	9989-518-003	Panel Assy., Front- white only	1
7	9989-518-001	Panel Assy., Front- S. Steel	1
8	9108-100-004	Door, Upper Service-S.S	1
8	9108-100-006	Door, Upper Service-White	1
9	9578-090-002	Trim, Door-Upper Service	1
6292-006-006		Key (only) (FJWCC)	1
10	8650-006-003	Lock w/ nut, Upper Service Door	1
*	9491-009-001	Rivet, Drive	2
*	8641-581-005	Washer, Flat 3/16"	2
*	9548-268-001	Support, Upper Door	1
11	9412-127-001	Nameplate, Industrial Dryer	1
12	9545-012-003	Screw, Chrome 10-32 x 1/2"	4
*	8641-436-004	Washer, Fiber	4
*	8641-582-019	Lockwasher # 10	10
*	8640-399-001	Nut, Spring U type 10Z	6
13	9544-069-002	Strap, Hinge (White)	1
13	9544-069-004	Strap, Hinge (Gray)	1
*	9545-012-003	Screw, to Panel 10T-32 x 1/2" Strap	4
14	9545-052-001	Screw, Door to Hinge Strap (special)	1
*	8641-436-003	Washer, Fiber/ Plastic VSCO on Door Hinge (special)	1
15	9960-281-001	Door Ass'y, Lower Service-SS	1
15	9960-281-003	Door Ass'y, Lower Service-White	1
16	9578-088-001	Trim, Door - Lower Service	1
17	9545-008-021	Screw,Pn Hd Cr., #10Bx3/8	5
18	9578-084-002	Trim, Kick- Lower Service Door	1
19	9545-008-010	Screw, Tr Hd Cr-#10x1/2 Blk	3
20	9244-084-001	Latch, Lower Door (Handle)	1
23	9435-016-003	Overlay Trim	1
*	8502-617-001	Label - Made in the USA	1
*	9277-051-002	Insulation Side Panel	6

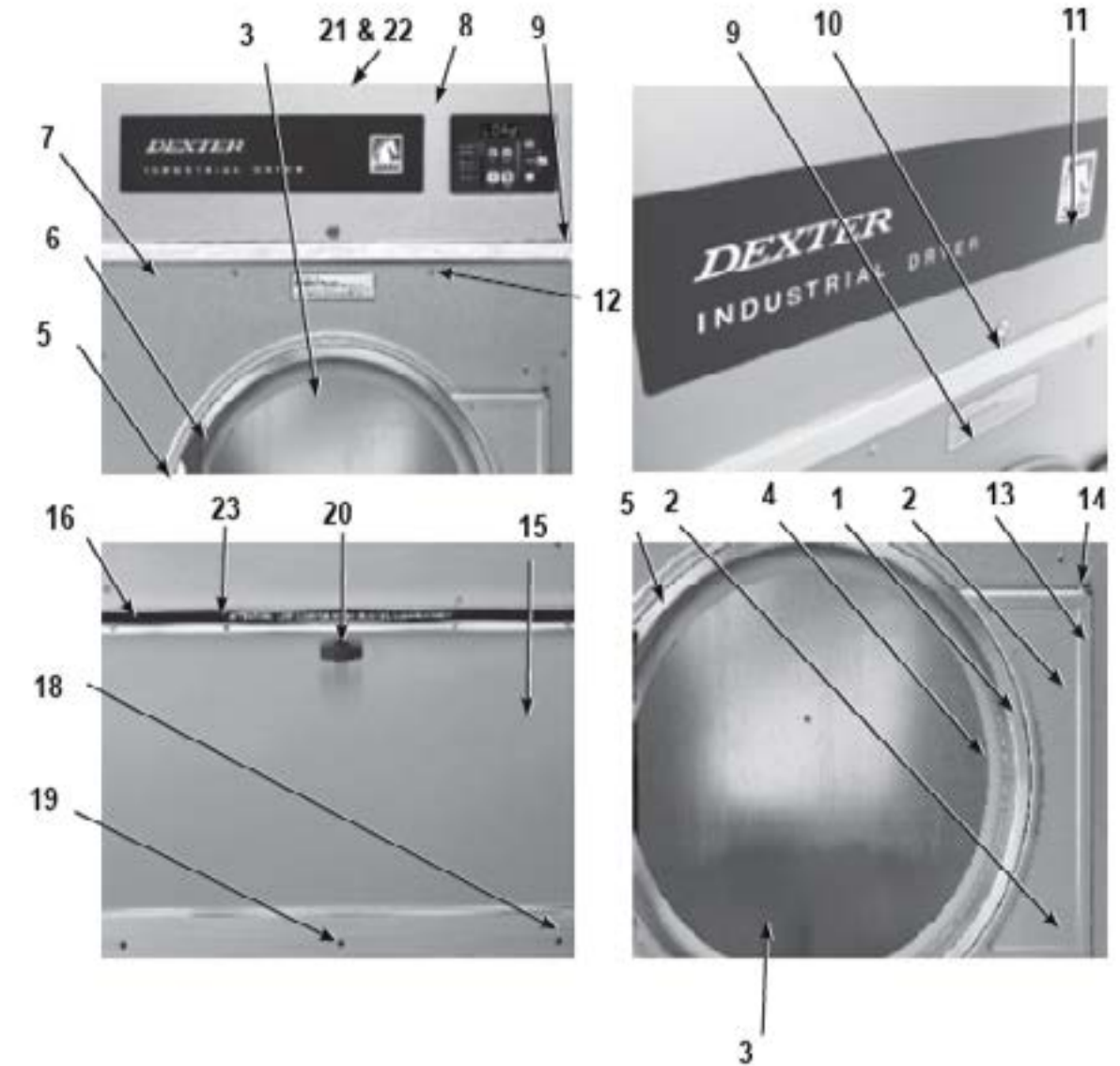

Key	Part Number	Description	Qty
*	9277-051-001	Insulation Side Panels	6
*	9277-056-002	Insulation Front Panel Bottom	1
*	9277-056-001	Insulation Front Panel Top	1
*	8544-056-001	Leg, Leveling	4
*	9049-074-001	Baffle, Cabinet- Left Inside Cabinet	1
*	9049-074-002	Baffle, Cabinet- Right Inside Cabinet	1
*	9545-008-003	Screw, #10x1/2 TEK	8
21	9074-273-001	Cover, Cabinet	1
22	9545-008-024	Screw 10AB x 3/8"	10
*	9277-050-002	Insulation Lower Service Door	1
*	9277-047-001	Insulation	1
*	9277-047-002	Insulation 1/4" black	1

Drive Group

Key	Part Number	Description	Qty
1	9376-299-002	Motor, Drive	1
*	9545-014-004	Screw, Hx 5/16-18 x 5/8"	4
*	8640-400-003	Nut 5/16-18	4
2	9453-157-001	Pulley, Motor	1
*	9545-028-013	Screw, Set	2
3	9991-054-002	Support Assembly, Motor	1
4	9545-029-005	Screw 3/8-16 x 1 1/4"	4
4	8640-415-004	Nut 3/8-16	4
5	9991-053-001	Support Assembly, Intermed. Pulley	1
6	9545-029-010	Bolt, Rd Hd, 3/8-16 x 1 1/4"	3
7	9545-029-003	Screw, 3/8-16 x 1 1/2"	1
8	8640-415-004	Nut 3/8-16	3
*	8641-581-035	Washer, Flat	4
9	9861-024-003	Arm Assembly-Tension	1
*	8641-581-035	Washer, Flat	1
*	9487-200-006	Ring-Retaining	1
10	9908-042-006	Pulley Assembly, Intermediate - w/bearings	1
11	9036-159-007	Bearing, Ball-Idler Pulley	2
*	9538-173-002	Spacer, Bearing	1
12	9908-043-002	Pulley Driven	1
*	9487-234-001	Ring, Tolerance	1
13	8641-581-026	Washer, Flat	1
13	8641-582-016	Lockwasher	1
13	9545-017-009	Screw, Hx Cap	1
14	9040-077-004	Belt, Final Drive	1
15	9040-077-003	Belt, Motor Drive	1
16	9534-151-000	Spring, Belt Tension	1
17	9099-012-002	Chain, Spring Tension	1
18	9248-022-002	Hook, Tension	1
21	9208-067-001	Guard, Drive	1
22	9454-685-001	Panel, Drive Guard, RH	1
23	9454-686-001	Panel, Drive Guard, LH	1
24	9550-175-001	Shield, Motor	1
25	9545-008-003	Screw	2
26	9545-008-024	Screw (to attach to guards above)	24
19	9074-275-004	Blower Impeller Cover (flat)	1
20	9074-275-005	Blower Impeller Cover (formed)	1

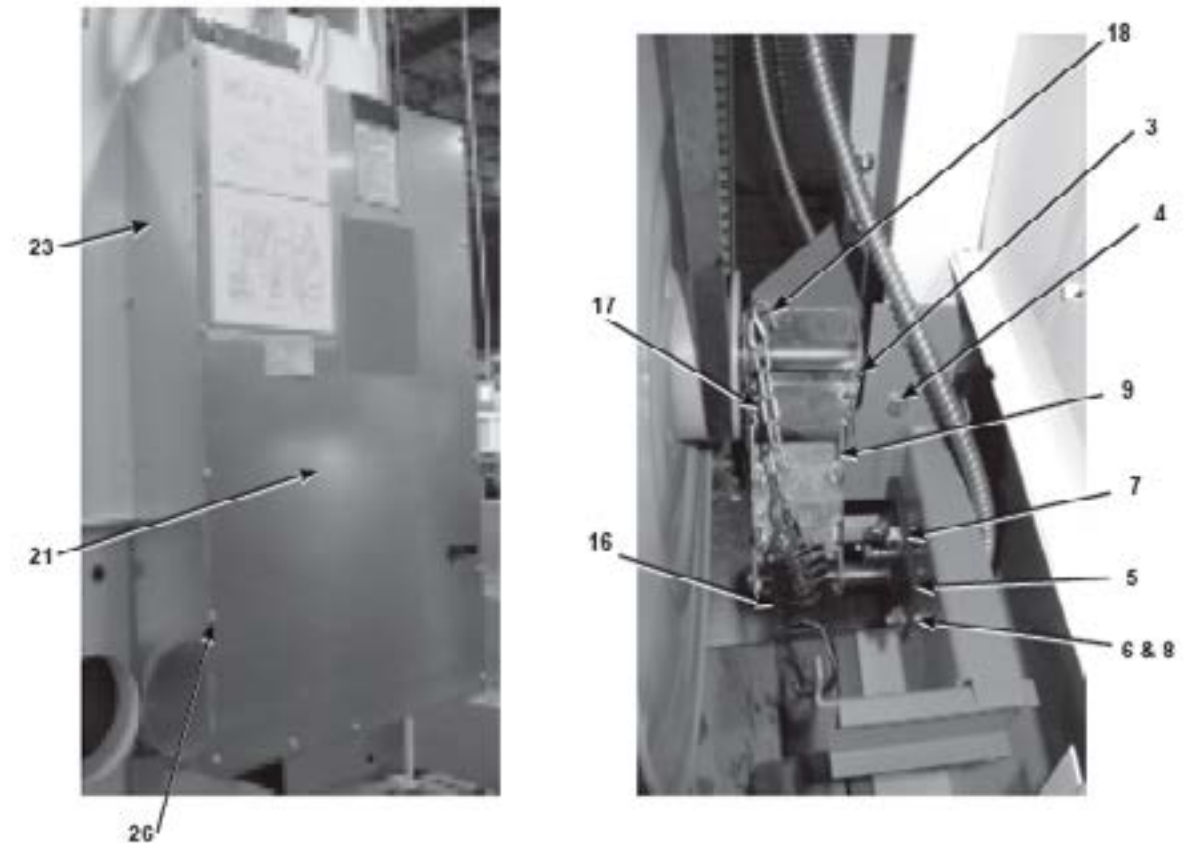
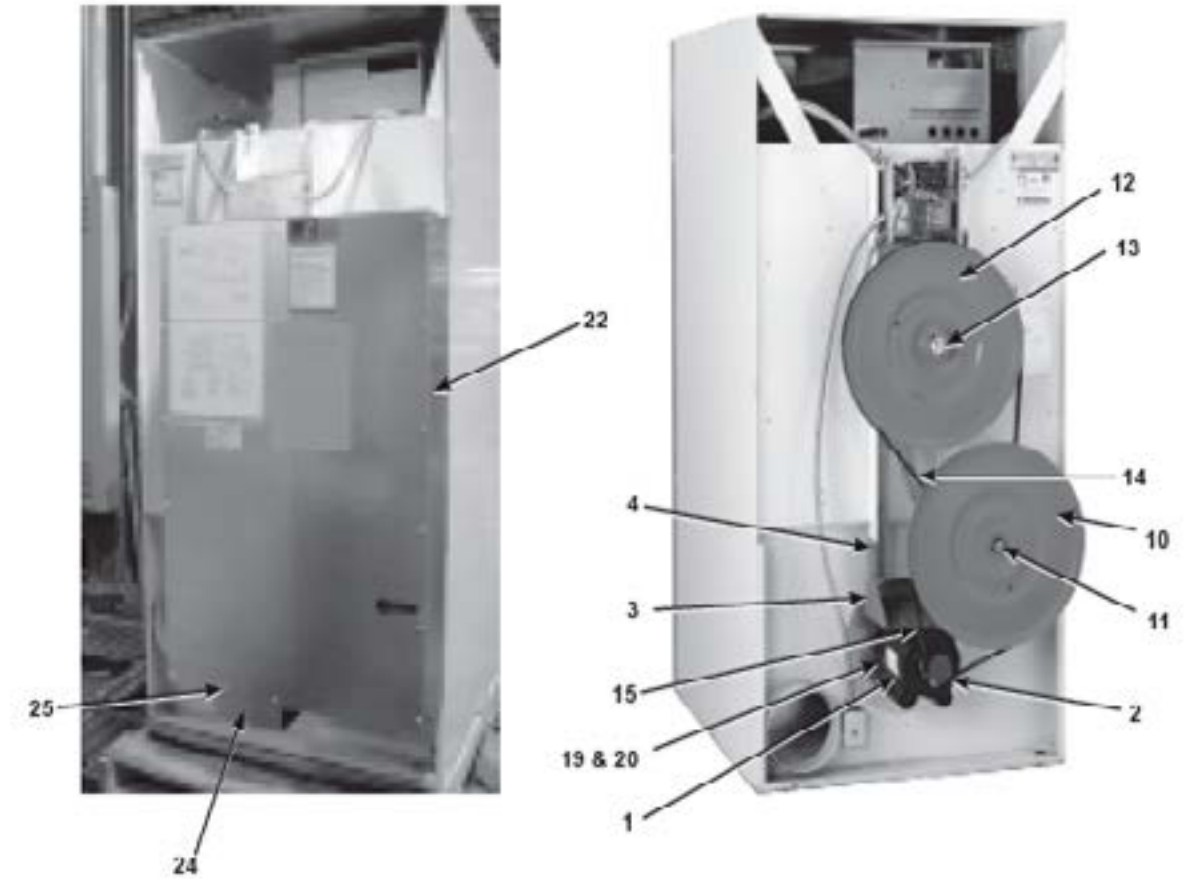

Rear Control Group

Key	Part Number	Description	Quantity
1	9041-081-001	Box , Control.....	1
*	9074-304-001	Cover, Control Box Upper.....	1
*	9545-008-024	Screw 10AB x 3/8".....	4
2	5192-295-011	Relay (Large).....	1
*	9545-044-002	Screw, #8ABx 3/8.....	2
3	9897-035-002	(4 Pole) Terminal Block Assembly, Power	1
4	9558-029-003	Strip , Terminal Marker (4 Pole).....	1
*	9545-045-002	Screw, #8ABx 3/8.....	2
*	8641-582-006	Lockwasher, Ex Tooth # 10.....	1
*	9074-305-001	Cover control box lower.....	1
5	8639-621-007	Screw #10-32 x 1/2 GRN.....	1
*	8640-411-003	Nut Hexkeys #6-32.....	2
6	8711-007-001	Transformer.....	1
*	9545-012-009	Screw--#10-32 x 1/2" Mount Transformer	2
*	8640-413-002	Nut Hexkeys #10-21 UNF Mount Transformer	2
*	8220-001-230	Wire Assembly Black/Red 8 1/2".....	1
*	8220-001-231	Wire Assembly Black/Blue.....	1
*	8220-001-452	Wire Assembly White 12 1/4".....	1
*	8220-001-478	Wire Assembly Green 7".....	1
*	8220-067-001	Wire Assembly Black/Red 7 3/4".....	1
*	8220-067-002	Wire Assembly Black/Blue 7 3/4".....	1
7	9897-034-001	Terminal Block Assembly (6 pole).....	1
*	9558-027-001	Strip Terminal Marker (6 pole).....	1
*	8220-001-230	Wire Assembly Black/Red 8 1/2" Jumper	1

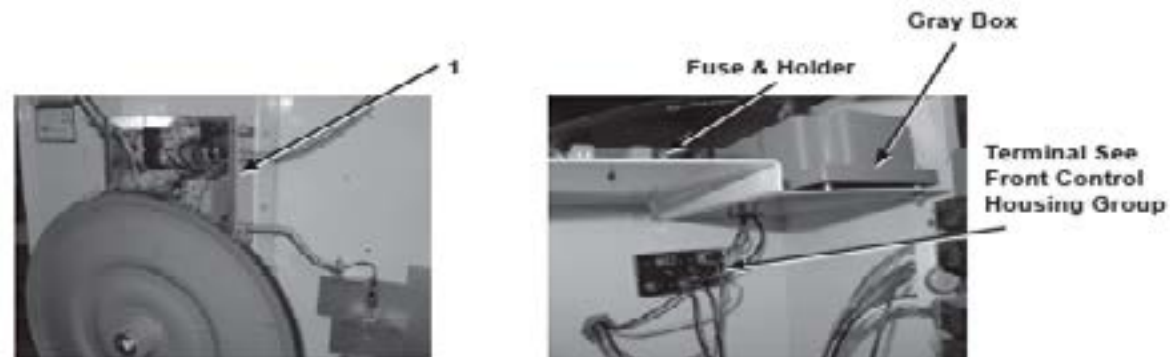
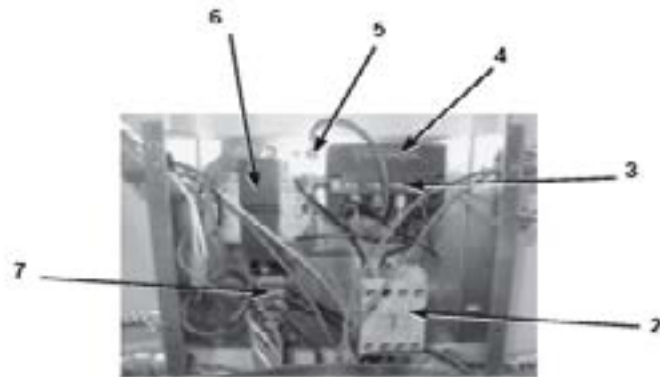

Door Switch Group

Key	Part Number	Description	Quantity
1	9041-076-001	Box, Door Switch.....	1
2	9550-159-001	Shield, Door Switch.....	1
3	9539-461-007	Switch, Door.....	1
4	8640-401-001	Nut, Special Twin #4-40.....	1
5	9545-020-001	Screw, Pn Hd Sl.#4-40x5/8.....	2
6	9074-255-001	Cover, Switch Box.....	1
7	9545-008-020	Screw, Box Cover 10 AB x 3/4".....	2
8	9008-004-001	Actuator, Switch.....	1
9	6068-041-001	Conduit Special.....	1
10	9545-012-003	Screw. 10-32 x 1/2".....	1
*	8641-436-000	Washer, Fiber.....	1
11	8640-413-004	Nut, ElasticStop 10 -32.....	1

* Not Illustrated

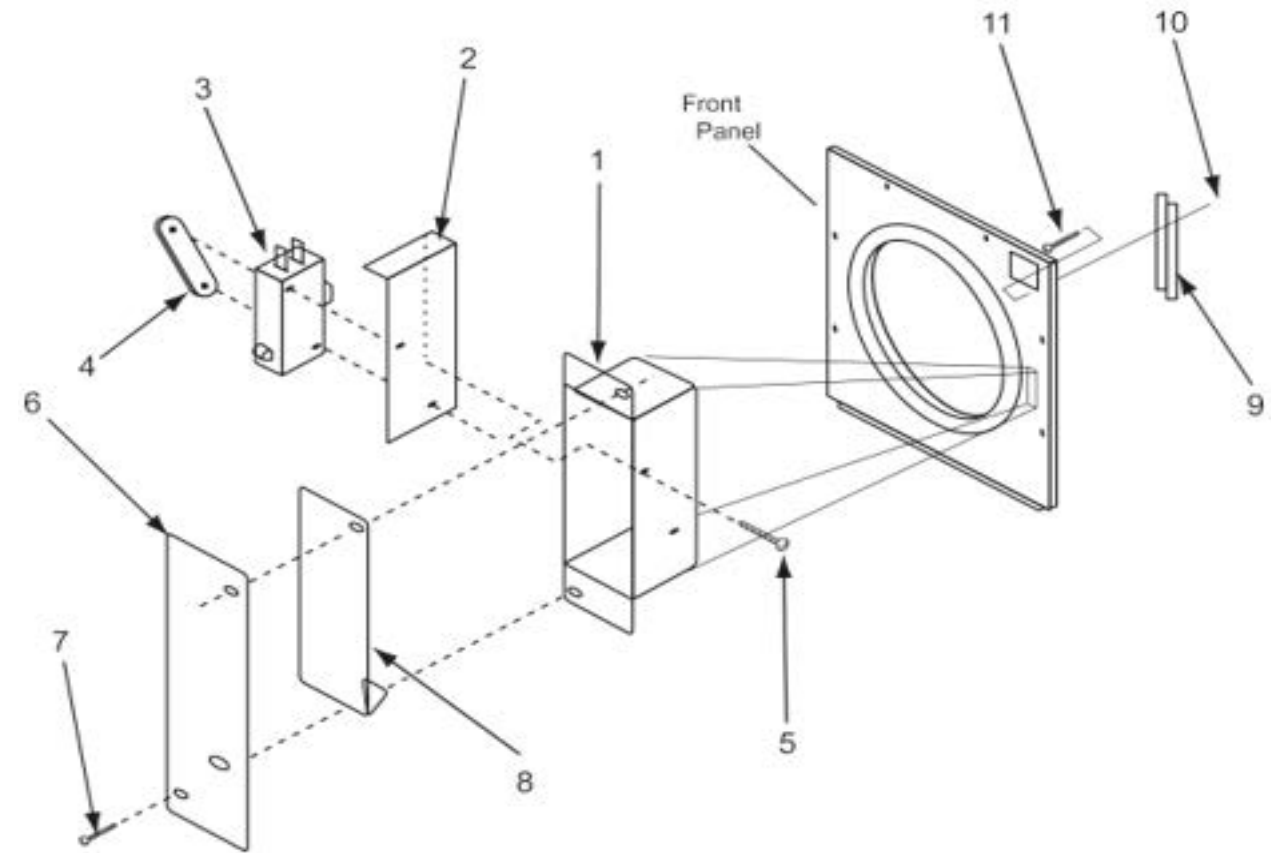

Burner Housing Group

Key	Part Number	Description	Quantity
1	9803-195-001	Housing Assembly, Burner	1
*	9545-008-024	Screw	4
2	9048-018-001	Burner, Main	4
*	9545-008-008	Screw 10T-32 x 1/2	4
3	9875-002-002	Electrode, Ignition	1
4	9452-645-001	Plate, Electrode Mtg	1
5	9545-045-001	Screw, Electrode Mtg 8B x 11/4"	2
6	9857-134-002	Control Assy, Gas	1
7	9381-011-001	Manifold, Assy 4 port	1
*	9425-069-021	Orifice, Burner-Natural	4
*	9425-069-022	Orifice, Burner-LP	4
8	9576-203-002	Thermostat, Hi-Limit	1
*	9538-142-001	Spacer, Hi-Limit	2
*	9545-045-007	Screw 8B x 3/4"	2
19	9074-234-001	Cover, Hi-Limit Stat	1
*	9545-008-024	Screw 10 B x 3/8"	1
*	9857-116-003	Control, Ignition (Gray Box)	1
*	9545-044-002	Screw 6-32 x 1"	2
*	8640-411-003	Nut, Hex Keps #6-32	2
*	9897-026-001	Terminal Block Power (Inside Control Panel)	1
*	9545-031-004	Screw 6 AB x 5/8"	2
*	9039-915-001	BRACKET, Pipe gas line	1
*	9545-008-003	Screw 6AB x 5/8"	2
21	9631-403-003	Wire Ass'y, High Voltage	1
20	9627-711-001	Harness, Low Voltage Ignition	1
*	9054-045-001	Fuseholder	1
*	8636-018-001	Fuse 1.5 amps	1
*	8711-007-001	Transformer, Control (In rear control box)	1
*	9545-008-026	Screw, #10x1/2"	2
*	9732-102-010	Kit, LP Conversion 4 Burner	1
13	9548-280-001	Support, Front Burner	1
14	9545-008-008	Screw 10T-32 x 1/2"	1
*	9454-731-001	Left side burner housing	1
*	9454-730-001	Right side burner housing	1
9	9379-164-002	Valve, Gas Shut-Off w/ brass union	1
*	9458-020-003	Pipe, Gas Line	1
*	9454-737-001	Front Side Burner Housing	1

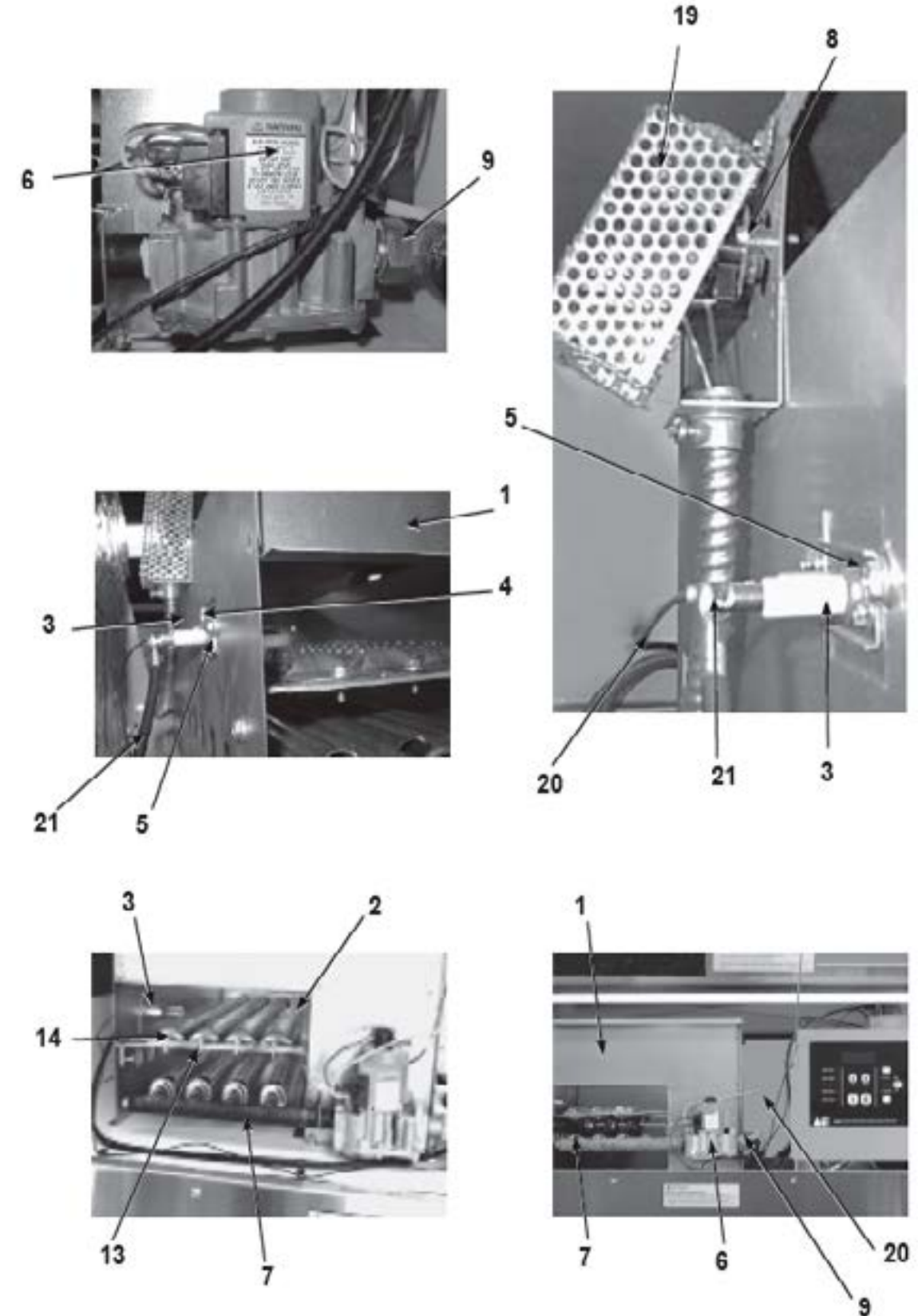

Bearing Housing Group

Key	Part Number	Description	Qty
*	9803-189-001	Housing, Bearing Ass'y w one(rear) bearing	1
1	9241-183-003	Housing, Bearing	1
2	9036-159-001	Bearing, Ball-Rear	1
*	9036-159-002	Bearing, Ball-Front	1
3	8641-581-026	Washer, Flat 1/2"	4
4	8641-582-004	Lockwasher spring 1/2"	4
5	9545-017-004	Bolt, 1/2-13x1	4
6	9545-059-003	Screw, 7/16-14x1 1/2	2
*	8641-582-013	Lockwasher, 7/16	2
7	8640-416-001	Nut, 7/16-14.	4
*	9487-234-001	Ring, Tolerance	1

* Not Illustrated

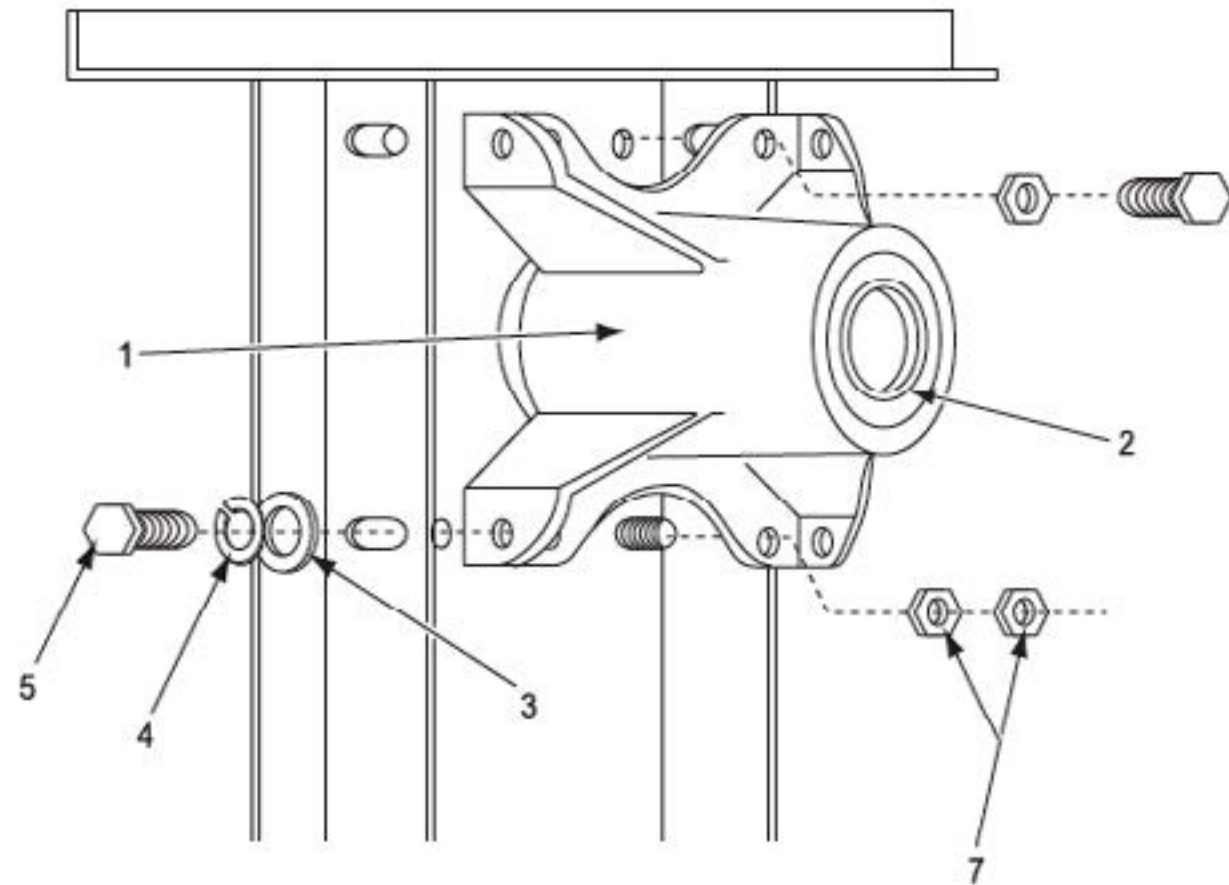

Tumbler Basket Group

Key	Part Number	Description	Qty
1	9848-133-001	Tumbler Ass'y	1
*	9848-118-002	Tumbler Ass'y SS.....	1
2	9873-005-001	Spider Ass'y with bearing on.....	1
3	9497-226-001	Rod, Tumbler	4
4	8640-417-005	Nut 1/2"-13.....	4
5	9552-013-000	Shim.....	4
7	8641-590-001	Washer, Tumbler Rod Special	4
*	9487-234-001	Ring, Tolerance.....	1
8	8641-582-016	Lock Washer ext tooth 1/2", Tumbler Shaft	1
9	8641-581-026	Flat Washer 1/2",Tumbler Shaft.....	1
10	9545-017-009	Screw, Tumbler Shaft 1/2-13 x 11/4"	1

* Not Illustrated

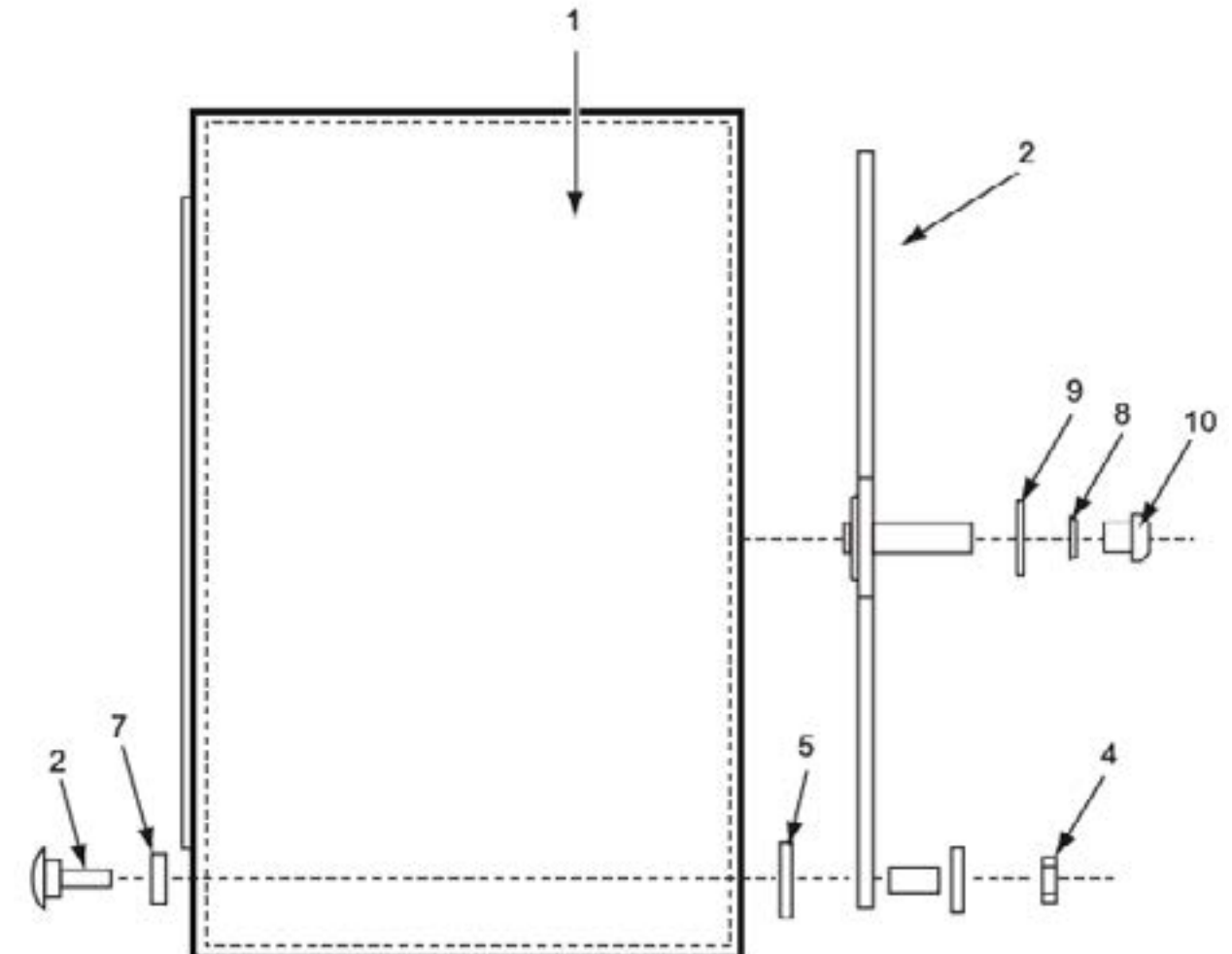

Blower Impeller and Air Flow Switch Group Over Temperature Switch

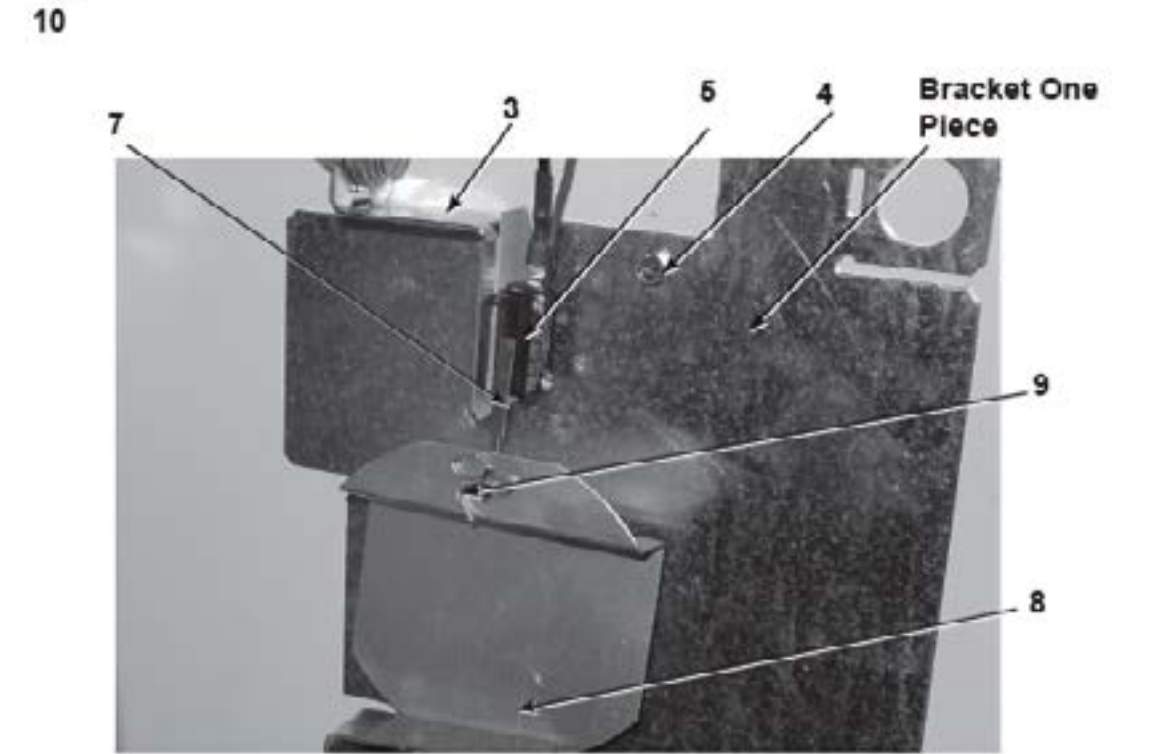

Key	Part Number	Description	Quantity
3	9029-135-001	Bracket -Switch One Piece.....	1
4	9545-008-024	Screw-10B x 1/4.....	2
5	9539-461-009	Switch-Micro.....	1
12	9545-020-001	Screw 4-40 x 5/8.....	2
*	8640-401-001	Nut Twin.....	1
8	9008-007-001	Actuator-Switch.....	1
9	9451-169-002	Pin Cotter.....	1
13	9039-575-000	Bracket Conduit.....	1
11	9825-057-002	Over-tempcoverass'y.....	1
*	9576-207-006	Thermostatover-tempMnl.....	1
*	9545-008-024	Screw 10B x 3/8.....	2
*	9550-169-003	Shield for macro switch.....	1
17	9834-009-001	Hood Assembly, Lint.....	1
*	8640-412-004	Nut, Whizlock.....	6
14	9822-031-002	Lint Screen 34" length (newest style).....	1
10	9278-037-003	Impeller, w/set screws.....	1
15	9501-004-002	Temperature Sensor Probe.....	1

* Not Illustrated

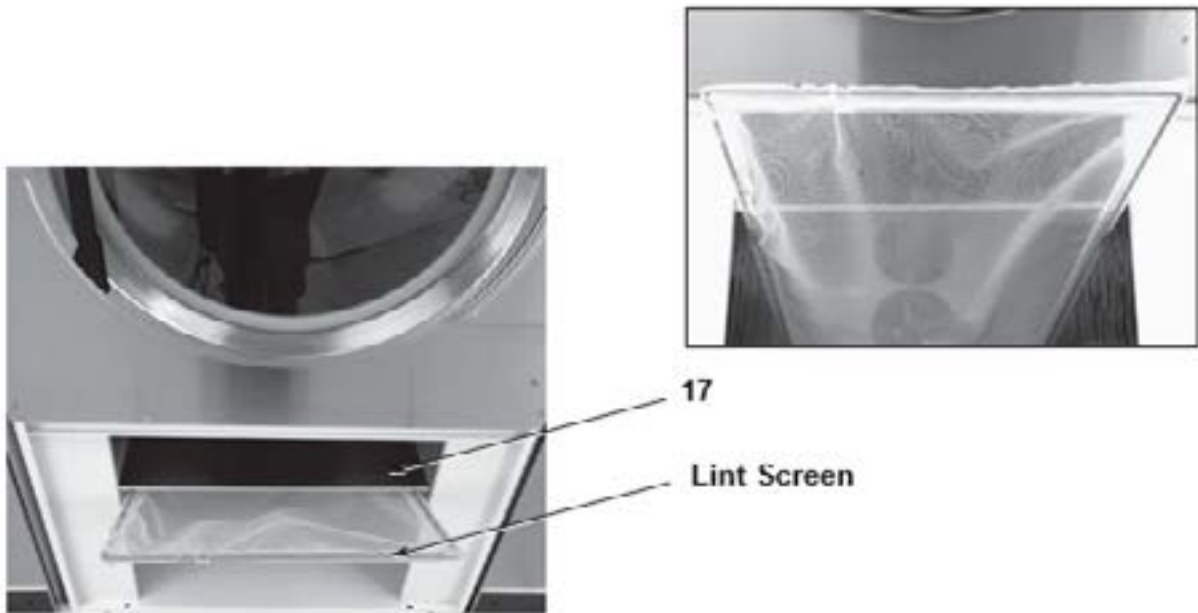

Wire & Harness Group

Key	Part Number	Description	Qty
*	8220-001-486	BRN 26".....	1
*	8220-001-499	BLK 26".....	1
*	8220-101-002	BLK 64".....	1
*	8220-101-007	Wire Assembly VIO 54".....	1
*	8220-101-004	Wire Assembly BRN 54".....	1
*	2114-008-000	Bushing Anti Short.....	1
*	8220-001-221	Door Switch Wire Assembly BLK 45".....	1
*	8220-001-222	Door Switch Wire Assembly BLU 45".....	1
*	8220-001-461	Wire Assembly WHT 58".....	1
*	8220-062-007	Wire Assembly BLK 74".....	1
*	8220-064-001	Wire Assembly GRY 61".....	1
*	8220-064-012	Wire Assembly RED 61".....	1
*	8220-065-021	Wire Assembly VIO 61".....	1
*	8640-276-003	Wire Nut #73 B ORG.....	1
*	8220-103-003	Wire Assembly GRY 64".....	1
*	8220-001-230	Wire Assembly BLK/RED 8.5".....	1
*	8220-001-231	Wire Assembly BLK/BLU 6.5".....	1
*	8220-001-452	Wire Assembly WHT 12" - 4".....	1
*	8220-001-478	Wire Assembly GRN 7".....	1
*	8220-067-001	Wire Assembly BLK/RED 7 3/4".....	1
*	8220-067-002	Wire Assembly BLK/BLU 7 3/4".....	1
*	8220-001-466	Wire Assembly Yellow 4 7/8".....	1
*	9627-711-001	Low Voltage Harness.....	1
*	9637-403-003	High Voltage Harness.....	1
*	8220-001-290	Wire Assembly BLK 20".....	1
*	9627-679-002	Wire Harness Heat Sensor.....	1

Label Group

Key	Part Number	Description	Qty
*	8507-256-001	Instructions Uncrating.....	1
*	8514-072-001	Owners Booklet.....	1
*	8507-350-001	Instructions Dry Install / Start-Up.....	1
*	8507-330-001	Instructions TVSS.....	1
*	9345-899-001	Wiring Schematic.....	1
*	9345-890-001	Wiring Diagram.....	1
*	8511-001-002	Label Quality.....	1
*	8502-658-001	Label Fire Hazard.....	1
*	8527-115-001	Label Decal Lighting and Clearance.....	1
*	8502-645-001	Label Instructions.....	1
*	8502-600-001	Label Warning and Notice.....	1

Rear Guard Group

Key	Part Number	Description	Qty
*	9208-067-001	Drive Guard.....	1
*	9454-685-001	Right Side Panel Drive Guard.....	1
*	9454-686-001	Left Side Panel Drive Guard.....	1
*	9550-175-001	Motor Shield.....	1
*	9545-008-003	Screw 10-16 x 1/2 TEK.....	2
*	9545-008-024	Screw 10 B x 1/4.....	24

Electric Heated Dryers Electrical Parts All Types of KW DCTD 80HC_16 FH 208/60/3 35 KW

Key	Part Number	Description	Quantity
*	5192-294-001	Relay - 125A.....	1
*	9377-003-001	Variator Coil Supply.....	1
*	5198-213-005	Circuit Breaker 3 Pole.....	2
*	8220-057-014	Wire Assembly Blk.....	3
*	9345-917-001	Schematic.....	1
*	9345-918-001	Diagram.....	1
*	9870-088-006	Heater Elements.....	2
*	5192-295-011	Relay.....	1
*	8502-711-001	Warning Label 208V.....	1
*	8220-057-004	Wire Brown 30".....	1
*	8220-057-007	Wire White/Black 45".....	1
*	8220-057-008	Wire Black 45".....	1
*	8220-057-011	Wire Violet 32".....	1
*	8220-057-015	Wire Black 8".....	6
*	8220-057-019	Wire White 8".....	1
*	8220-061-008	Wire Black 36".....	4
*	8220-061-010	Wire Black 48".....	2
*	8220-078-008	Wire Black 9".....	2
*	8220-078-011	Wire White 45".....	1
*	8220-078-012	Wire Red 45".....	1
*	8502-614-004	Label High Voltage.....	1
*	8502-708-001	Label Exhaust Warning.....	1
*	8514-092-001	Owners Book.....	1
*	9029-127-001	Guard Bracket Mounting.....	1
*	9208-053-001	Guard Front Cabinet Cover.....	1
*	9208-056-001	Guard Rear Cabinet Cover.....	1
*	9074-289-001	Cover Plate Control Box.....	1
*	9210-117-001	Gussett Control Box.....	1
*	9548-282-001	Support Wire.....	2
*	9074-288-001	Cover Plater Heater.....	1
*	9636-151-001	Wrapper Heat Housing LH.....	1
*	9636-152-001	Wrapper Heat Housing RH.....	1
*	9550-181-001	Shield Side Heathousing.....	2
*	9577-056-001	Top Heater Housing Half.....	2
*	9053-067-004	Bushing Insulated 1".....	6
*	9577-057-001	Top Box Control.....	1
*	9636-153-001	Wrapper Box Control.....	1
*	9058-025-001	Bottom Box Control.....	1
*	9053-067-004	Bottom Bushing Insulated.....	2
*	9295-004-001	Formed Jumper.....	2
*	9295-005-001	Straight Jumper.....	4
*	9488-010-003	Din Rail 4 3/4".....	1
*	9897-037-001	Power Block 3 Pole.....	1
*	9897-038-001	Power Block 1 Pole.....	1
*	9209-087-001	Grommet.....	1
*	8640-399-004	Nut Spring.....	1
*	8640-399-009	Nut Spring U Type.....	4
*	8502-639-001	Label Warning.....	1
*	8502-702-001	Label Warning Fire Hazard (French).....	1
*	8652-134-002	Terminal Lug Solderless.....	1

Electric Heated Parts Model Specific

DCTD 80H__ 16 FG 240/60/3 30 KW

Key	Part Number	Description	Quantity
*	5198-213-003	Circuit Breaker 3 Pole	2
*	5192-285-004	Relay	1
*	9870-088-002	Heater Elements	2
*	9345-965-001	Schematic	1
*	9345-966-001	Diagram	1
*	8220-057-014	Wire Black 8"	1
*	5192-294-001	Relay 125A	1

DCTD 80H__ 16 FE 208/60/3 30 KW

Key	Part Number	Description	Quantity
*	9345-963-001	Schematic	1
*	9345-964-001	Diagram	1
*	5198-213-004	Circuit Breaker 3 Pole	2
*	5192-285-004	Relay	1
*	5192-294-001	Relay 125 amp Resistive Contact	1
*	9870-088-001	Heater Elements	2
*	8220-057-014	Wire Black 8'	1

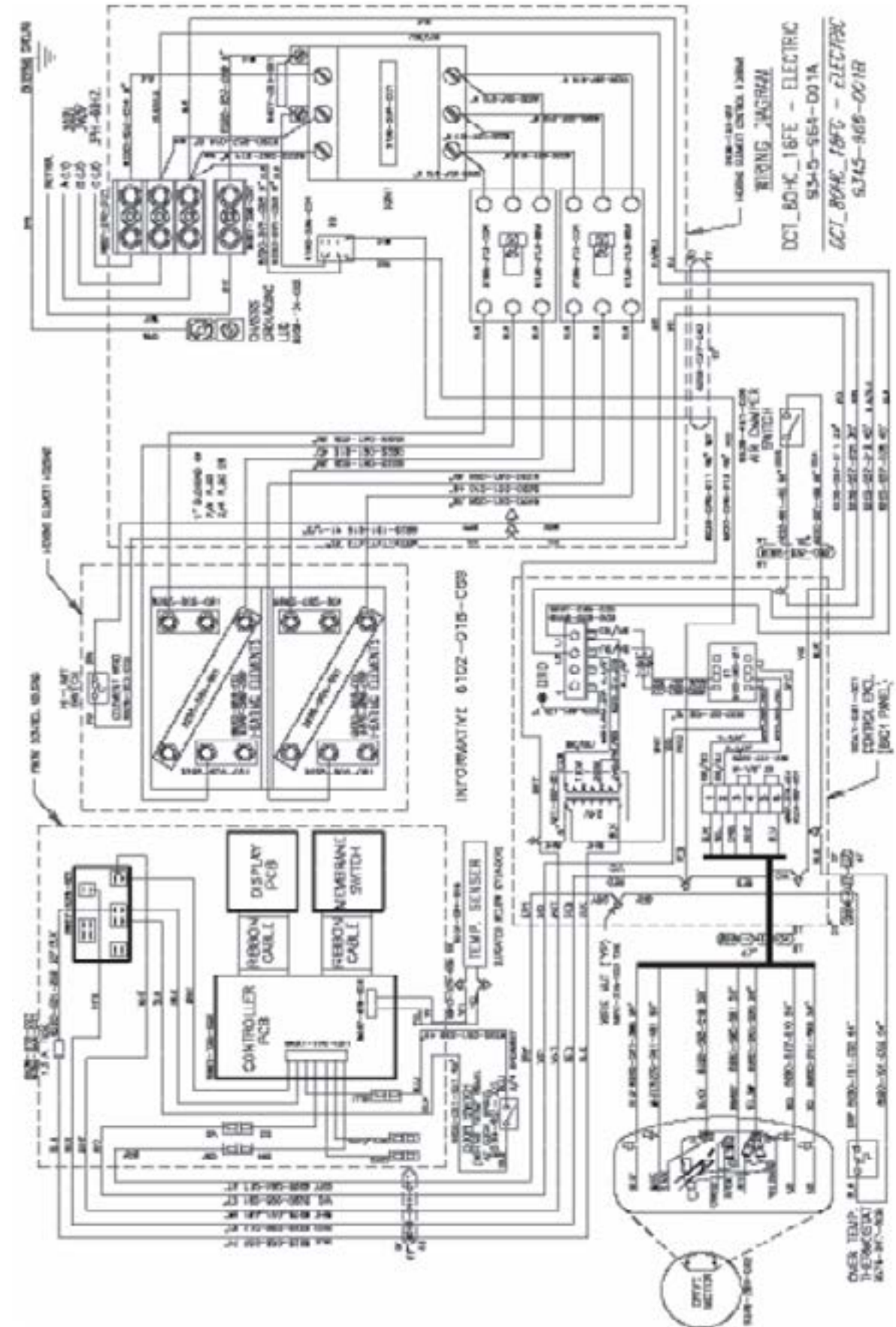

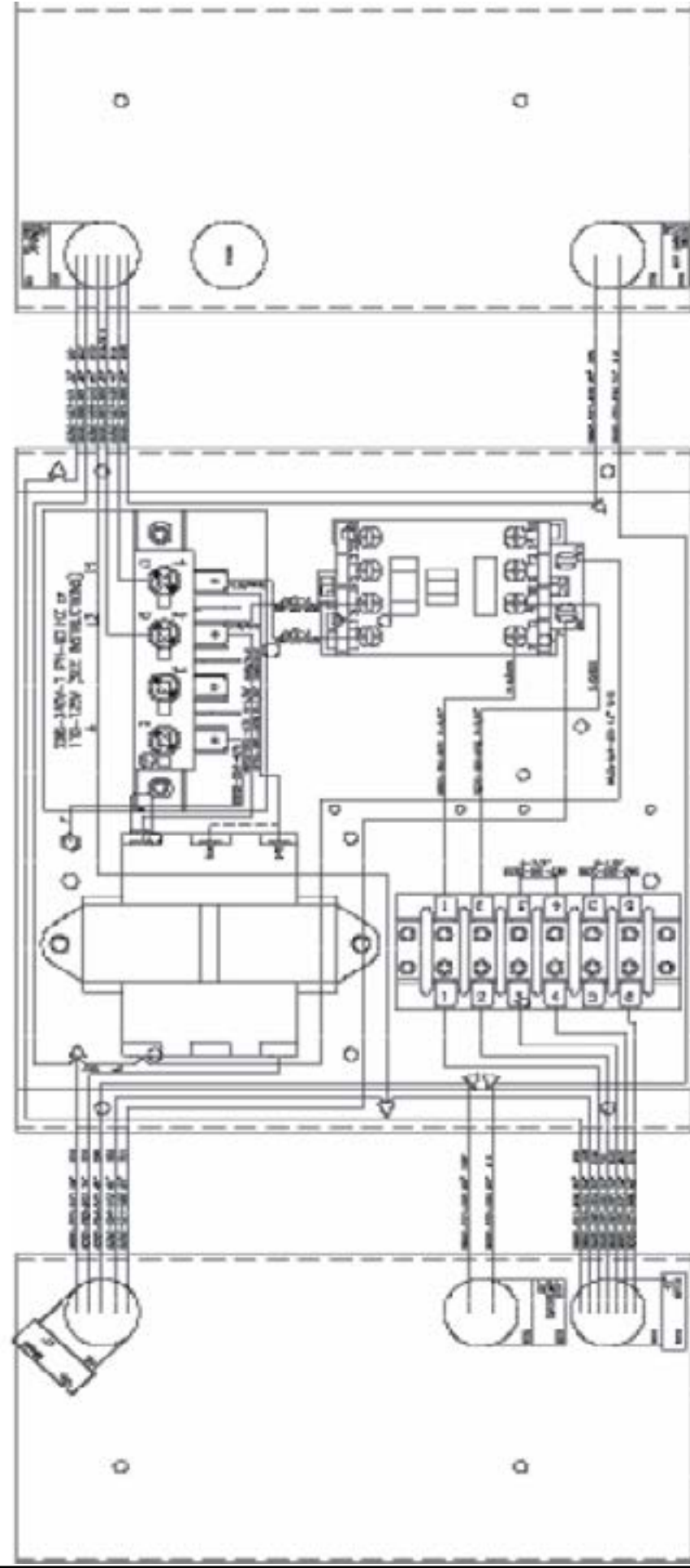

INFORMATIVE 6102-018-079

9041-081-001J

SAMPLE BOX

DCT_80HC_1(6,8)F(E,G,H) - ELECTRIC

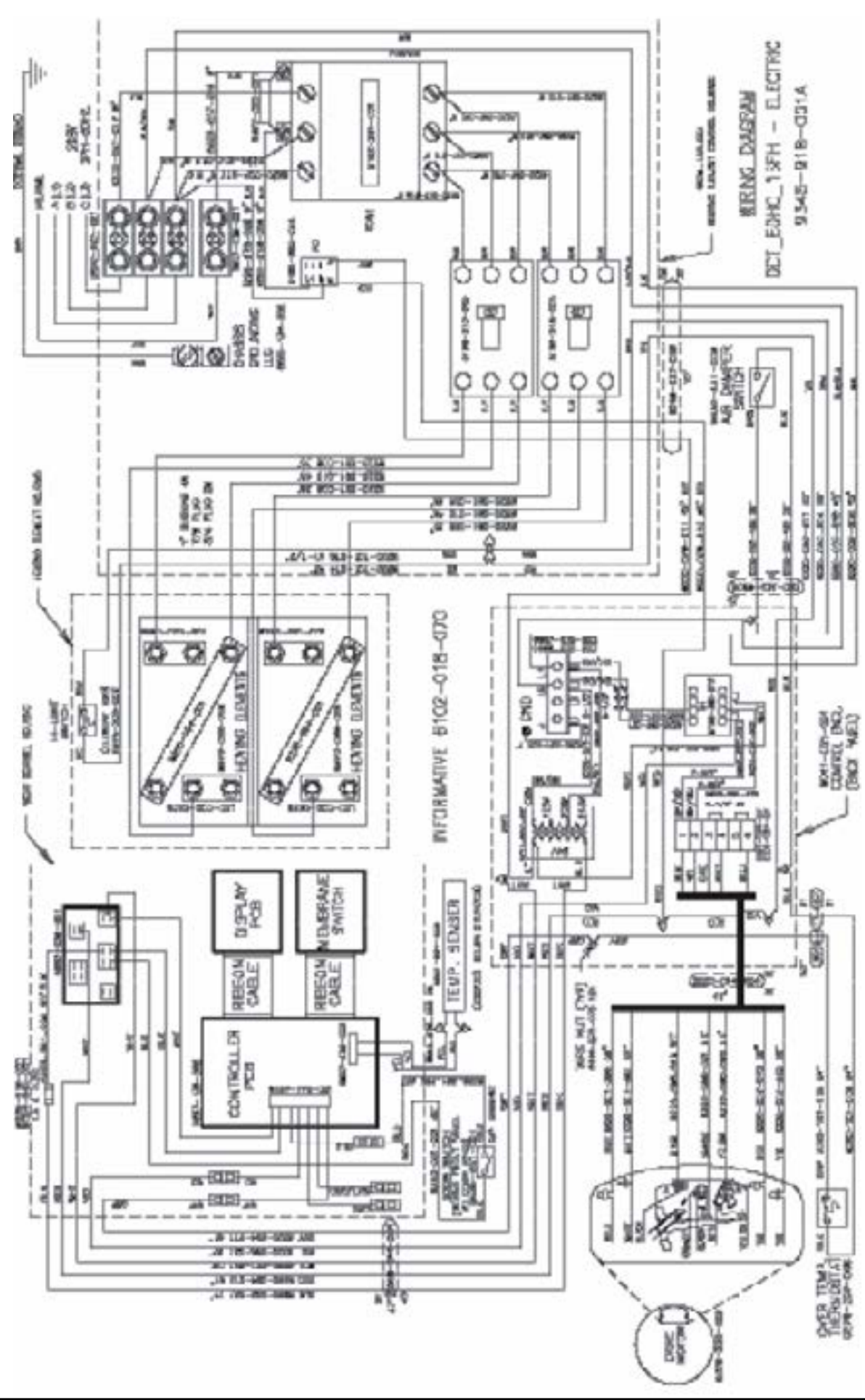

MIRING DIAGRAM
DCT_EDHC_1 1PH - ELECTRIC
9345-918-001A

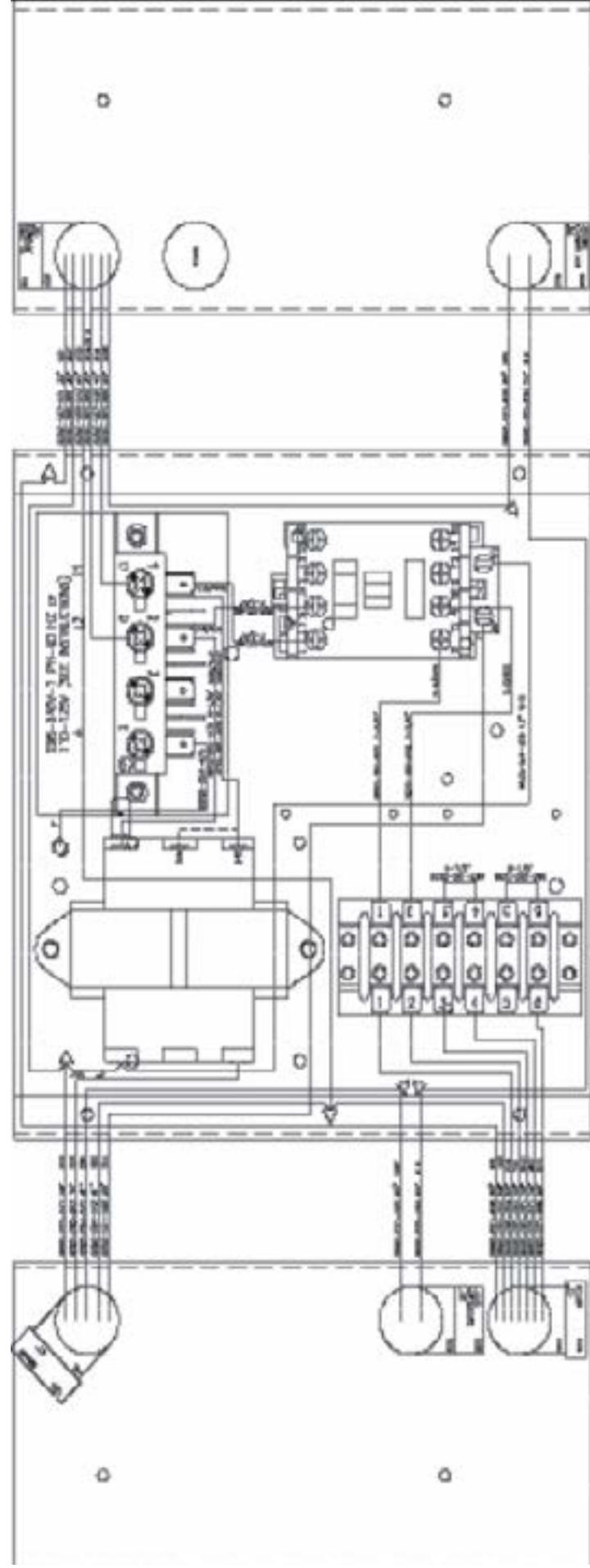

9041-081-001J

INFORMATIVE 6102-018-079

SAMPLE BOX

DCT_80HC_1(6,8)F(E,G,H) - ELECTRIC



INFORMATIVE 6102-018-080

9636-153-001B ELECTRIC BOX

DCT_80HC_1(6,8)F(E,G) - ELECTRIC

DCT_80HC_18FH - ELECTRIC

Steam Heated Parts Model Specific

Key	Part Number	Description	Qty
*	9799-021-001	Steam PCB Assembly Micro	1
*	9805-031-001	Lint Screen Assembly Intake	1
*	9506-025-001	Wire Diagram For 10 FS Model	1
*	9506-026-001	Wire Schematic For 10 FS Model	1
*	9486-154-001	Retainer Lint Screen Intake	1
*	9488-012-001	Rail Lint Screen Intake	1
*	9379-193-002	Steam Valve Solenoid	1
*	9242-465-001	Braided Steam Hose Stainless	2
*	9181-031-001	Frame Lint Screen Intake	1
*	9089-049-001	Coil Steam Heating	1
*	8514-137-001	Owners Manual	1
*	8502-717-001	Label Lint Screen	1
*	8220-078-017	Wire Assembly White 7"	1
*	8220-078-016	Wire Assembly Red 7"	1
*	8220-075-015	Wire Assembly Black/Yellow 40"	1
*	8220-067-002	Wire Assembly Black/Blue 7 3/4"	2
*	8220-064-039	Wire Assembly White Yellow 40"	1
*	8220-064-037	Wire Assembly Green 40"	1
*	8220-063-010	Wire Assembly Black/Red 7"	1
*	5192-285-004	Relay (clear)	1
*	5192-295-011	Relay (large)	1
*	9506-027-001	Wire Schematic for 60FS Model	1
*	9506-028-001	Wire Diagram for 60FS Model	1
*	9506-029-001	Wire Schematic for 61FS Model	1
*	9506-030-001	Wire Diagram for 61FS Model	1

Steam Wire Diagram 240 Volt

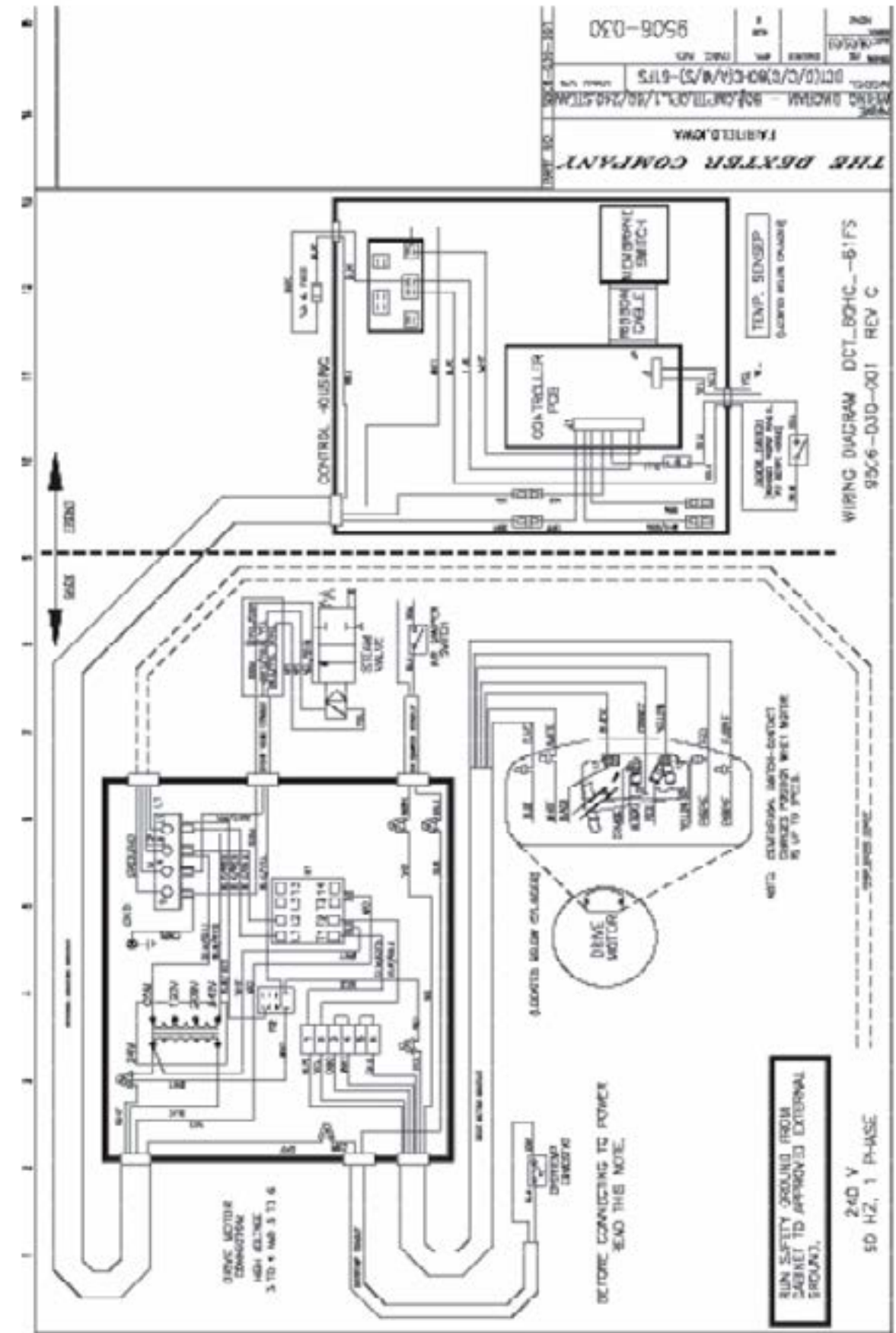

Steam Wire Diagram 120 Volt

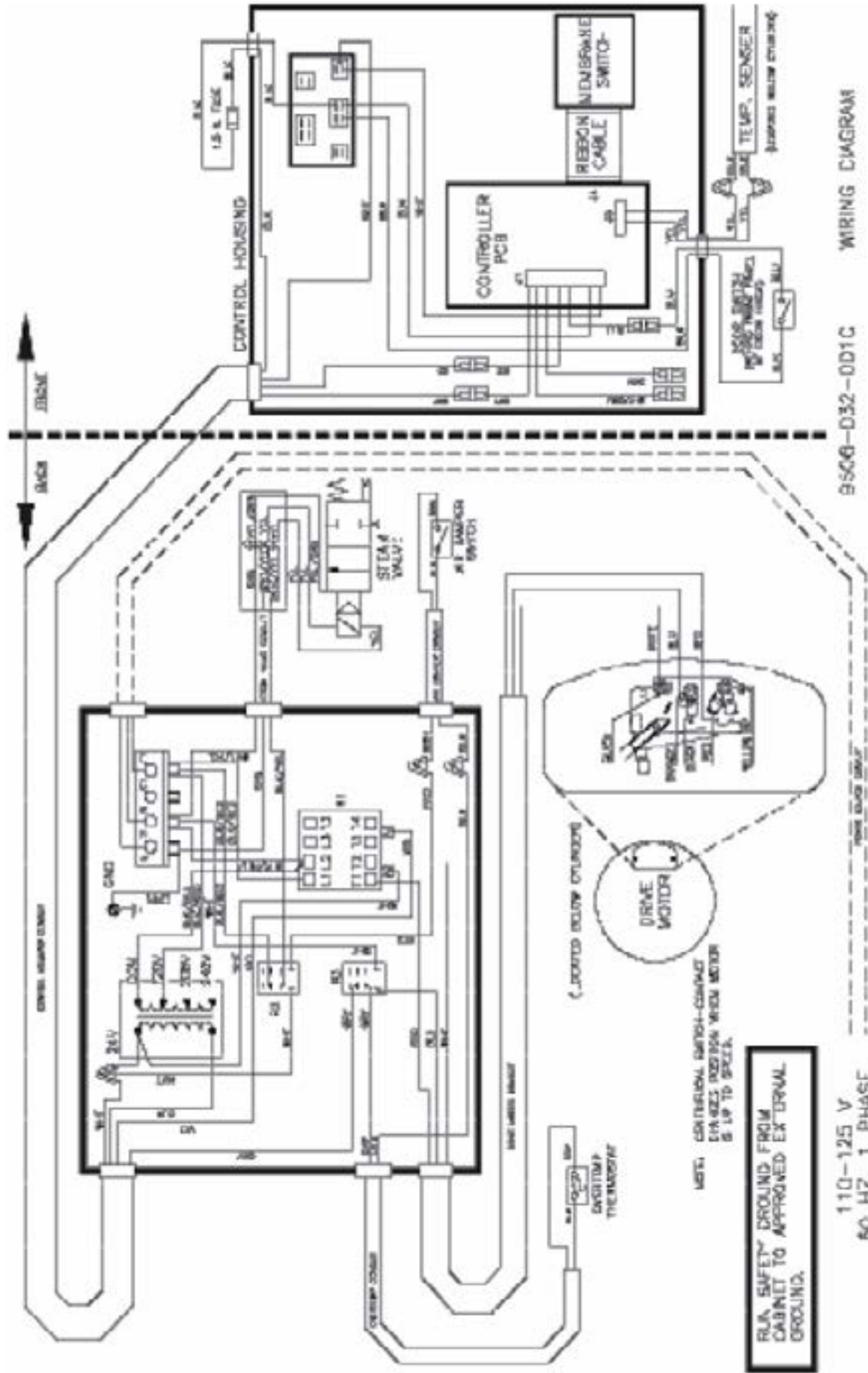

Steam Wire Informative

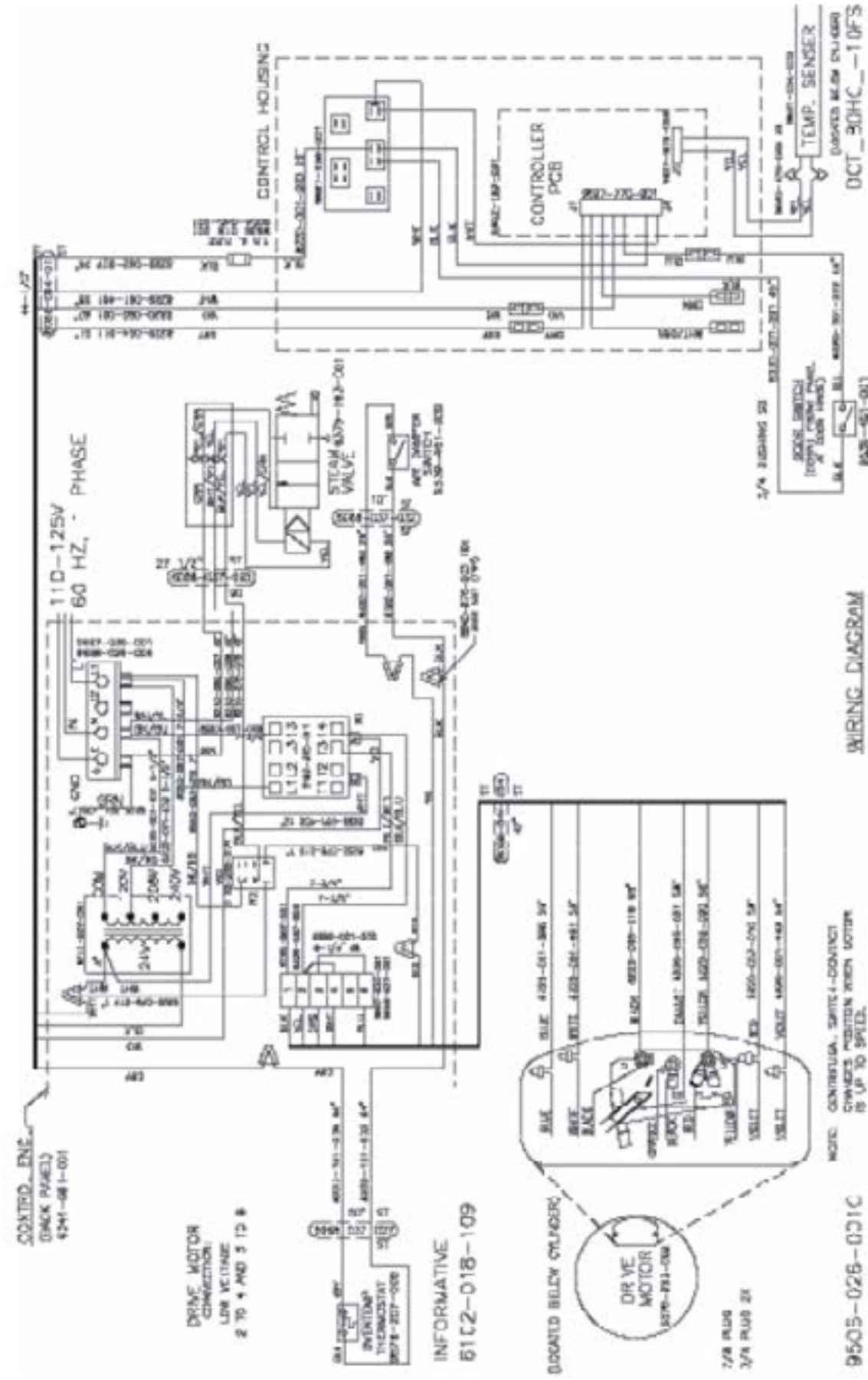

Steam Wire Diagram 208 Volt

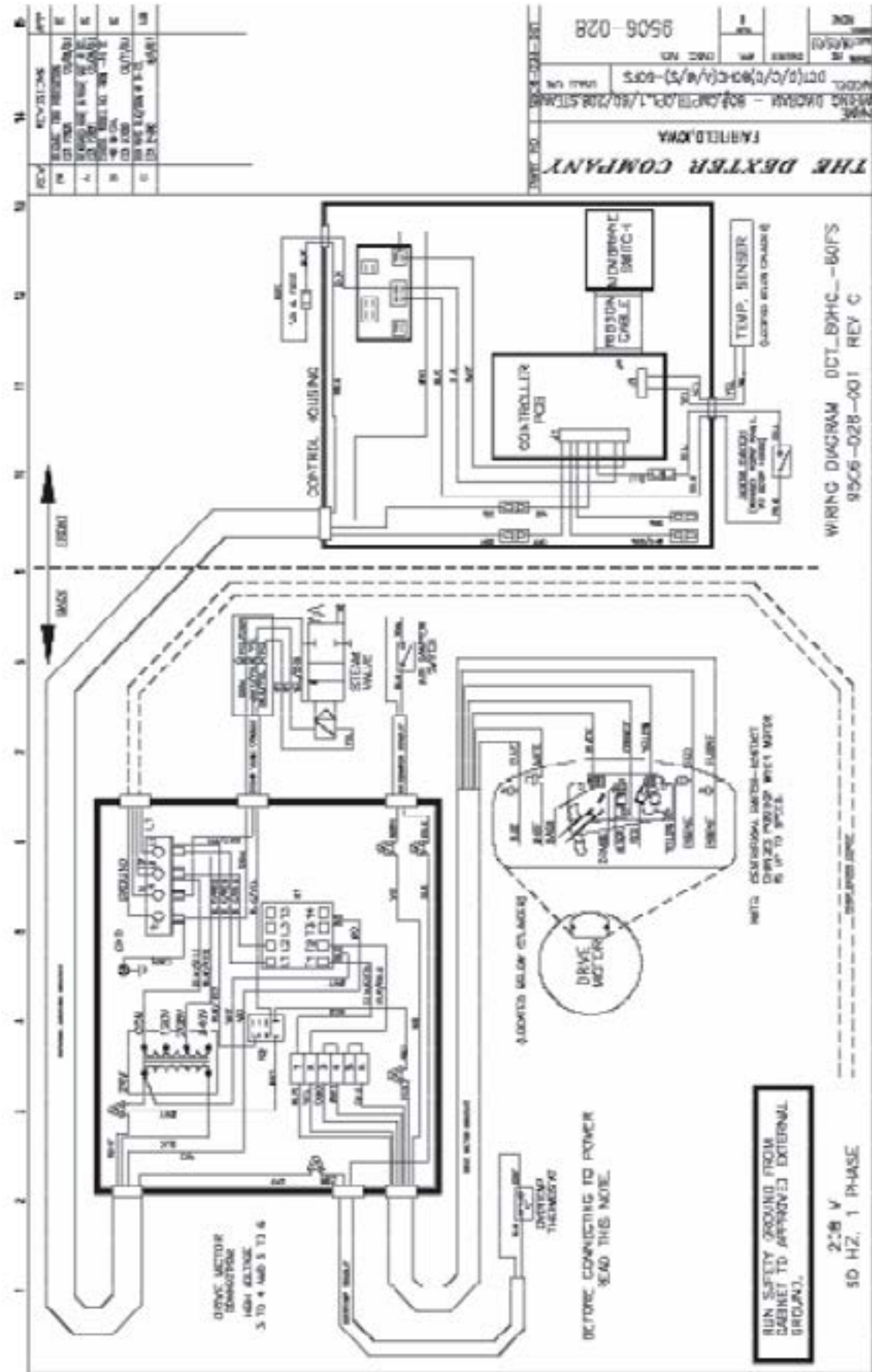

Electrical Components 50HZ

Key	Part Number	Description	Quantity
5	9558-029-005	Strip-Terminal, Marker	1
*	8220-001-230	Wire Assembly RED/BIK 81/2"	1
*	8220-001-282	Wire Assembly RED 20"	1
*	8220-001-461	Wire Assembly WHT, 58"	1
*	8220-001-479	Wire Assembly BIU, 45"	1
*	8220-001-480	Wire Assembly BIK, 45"	1
*	8220-001-524	Wire Assembly BIK, 46"	1
*	8220-001-530	Wire Assembly BIK, 67"	1
*	8220-001-531	Wire Jumper Assembly WHT, 12",4"	1
*	8220-065-006	Wire Assembly RED/BIK, 11"	1
*	8220-065-007	Wire Assembly BIK/BIU, 11"	1
*	8220-068-001	Wire Assembly BIK/RED, 5"	1
*	8220-068-003	Wire Assembly BIK/BIU, 5"	1
*	8220-088-002	Wire Assembly BIK, 5"	1
*	8220-097-002	Wire Assembly Jumper BRN	1
*	8220-098-003	Wire Assembly Jumper, YEI	1
*	8220-101-010	Wire Assembly YEUBIK, 62"	1
*	8220-101-011	Wire Assembly YEL, 62"	1
*	8220-101-017	Wire Assembly WHT, 3"	1
1	5192-295-010	Relay	1
2	8636-018-004	Fuse-2.5A	1
3	8711-008-002	Transformer-Control	1
4	9183-030-001	Filter-Line, EMI	1
*	9539-461-007	Switch-Micro, Door	1
*	8640-276-003	Nut-Wire connection, #73B, ORG	11
7	9631-403-005	Wire Assembly-High Voltage	1
8	9857-140-001	Control, Ignition	1
9	9453-169-009	Pulley-Drive Motor	1
*	9345-913-001	Wiring Schematic	1
*	9345-914-001	Wiring Diagram	1
*	8514-043-002	Booklet-Owners	1
*	9277-051-001	Insulation-Side Panel	1
*	8502-684-004	label- European Information	1
*	8502-680-001	CE-Rotation	1

Burner and Gas Valve components 50Hz.

Key	Part Number	Description	Quantity
*	9803-190-001	Burner Housing Assembly (Welded)	1
*	9048-018-001	Burner Assembly	3
*	9049-058-002	Baffle-Burner housing, Center	1
1	9381-010-002	Manifold Assembly (3 Port)	1
*	9425-069-020	Orifice-Plug, Main Burner, 3.9mm	3
2	9857-132-004	Valve Assembly-Gas	1
3	9732-162-001	Kit-VR86 Valve Flange	2
*	9791-001-002	Adaptor Assembly-Gas inlet	1
*	9000-043-001	Adaptor-3/4US to 3/4ISO Thred	1
*	9000-044-002	Adaptor European Exhaust	1

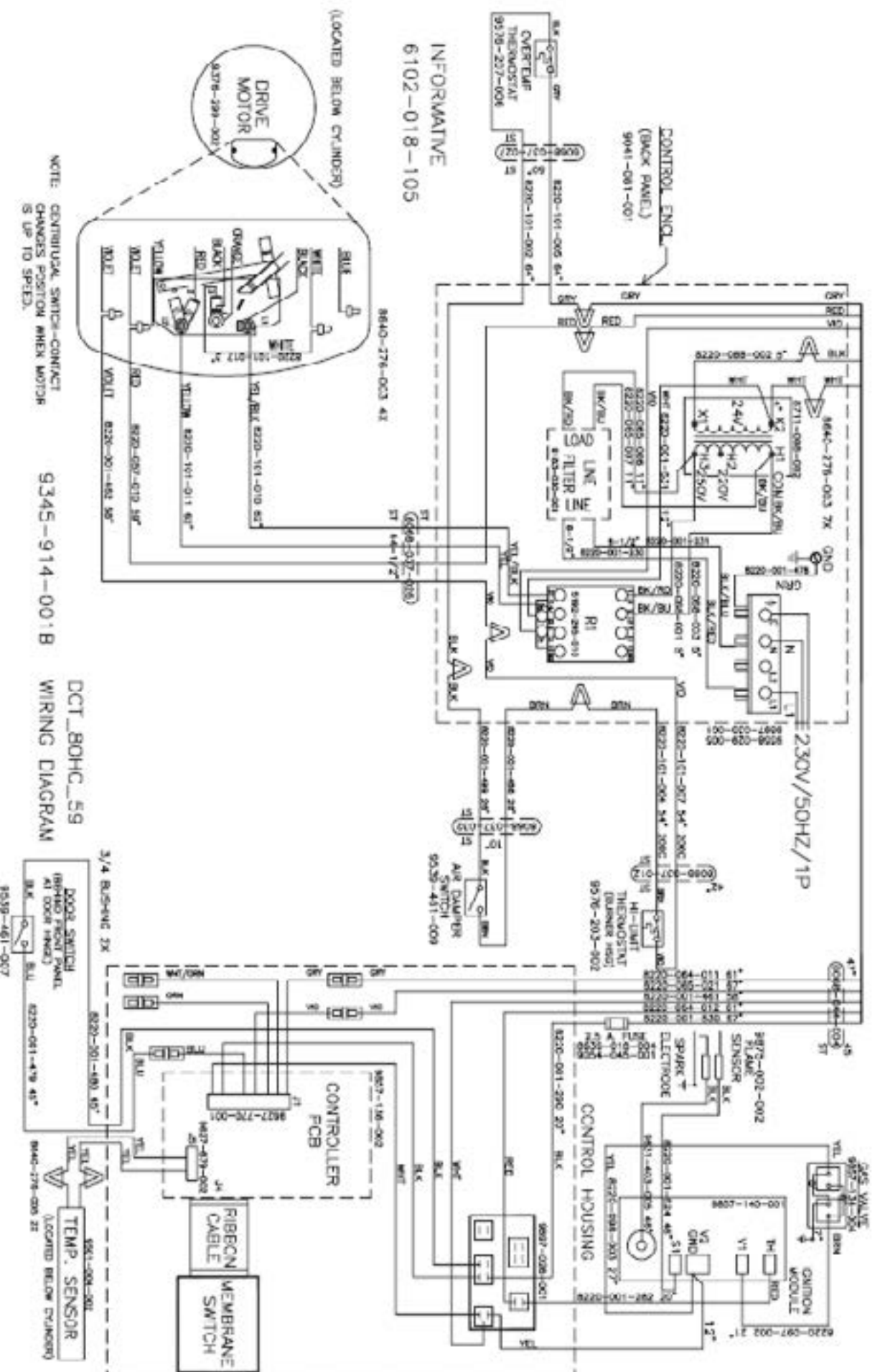
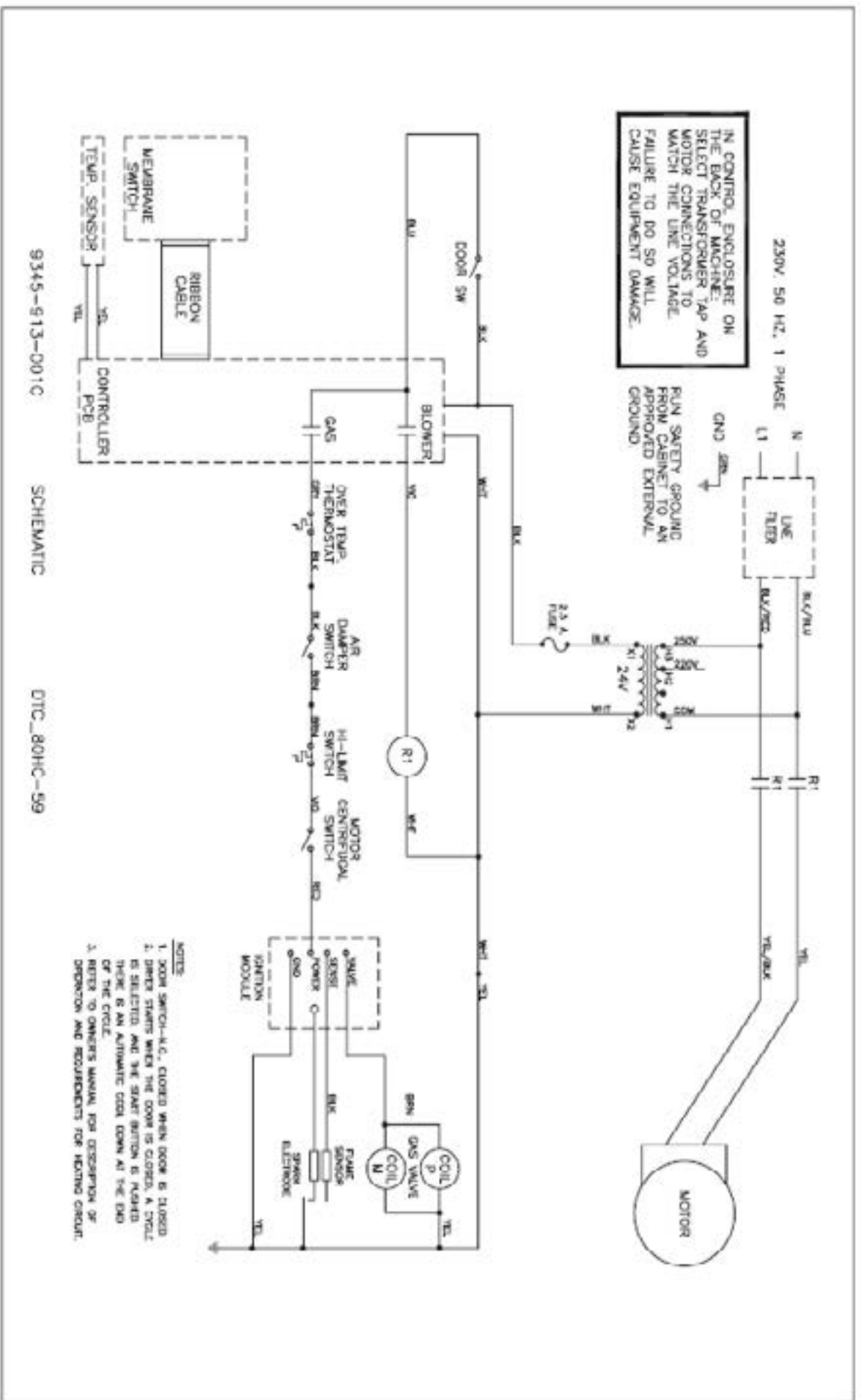

Section 7: Maintenance

Preventative Maintenance

Daily

1. Clean lint screen by unlocking and sliding out in their tracks for access. Use soft brush if necessary. Failure to do so will slow drying and increase gas usage and temperatures throughout the dryer.
2. Check lint screen for tears. Replace if necessary.

Monthly

1. Remove lint accumulation from end bells of motor.
2. Clean lint from lint screen compartment.
3. Remove lint and dirt accumulation from top of the dryer and all area above, and around the burners and burner housing. Failure to keep this portion of the dryer clean can lead to a build-up of lint creating a fire hazard.
4. Place a few drops of light oil on top and bottom pivots of the clothes door hinge.
5. Grease bearings and shaft of intermediate drive pulley.

Quarterly

1. Check belts for looseness, wear or fraying.
2. Inspect gasket of door glass for excessive wear.
3. Check tightness of all fasteners holding parts to support channel.
4. Check tightness of tumbler shaft retaining nut.
5. Remove lint accumulation from primary air ports in burners.
6. Grease pivot pins and tension arms where in contact with each other.

Semi-Annually

1. Remove and clean main burners.
2. Remove all orifices and examine for dirt and hole obstruction.
3. Remove all lint accumulation. Remove front panel, lint screen housing and remove lint accumulation.

Annually

1. Check intermediate pulley bearings for wear.
2. Check and remove any lint accumulation from exhaust system.