



VENDED LAUNDRY T-80 EXPRESS DRYER



T-80 EXPRESS DRYER

Dexter C-Series Dryer

Vended laundry solutions you can depend on.

Dexter C-Series vended dryers are engineered to show up for work in even the harshest laundry environments. Featuring upgraded controls and high quality materials, these fast and efficient dryers are designed to help make you more successful.

A store full of laundry equipment is a big investment and choosing the right equipment is an important decision. Our products will provide you the efficiency, flexibility, performance, and durability you need to be confident in your choice. With lifetime technical support and an industry leading 5-year limited warranty, you can be confident that we will stand behind every dryer you invest in.

Contact your Dexter Authorized Distributor today for more details.

EFFICIENT:

Perforated tumblers, balanced radial airflow, and the right amount of air recirculation provide maximum efficiency.

The anti-wrinkle feature offers an intermittent tumble to keep laundry wrinkle free.

DURABLE:

With heavy-duty bearings in a cast iron bearing housing, Dexter dryers are built to last.

Welded steel spider assemblies support the tumbler from the rear and eliminate the need for front support rollers.

The polished chrome or stainless steel doors and high-quality stainless steel panels keep dryers looking great year after year.

The screw resistant tumbler hole pattern minimizes tumbler damage.

RELIABLE:

Our industry leading 5-year warranty covers the trunnion, bearings, and bearing housing.

A 3-year parts warranty covers the rest.

We stand behind every machine you invest in with lifetime technical support.

PROFITABLE:

Every Dexter machine is now easier to use with a common user interface on all products, multiple language options, and detailed customer prompts.

C-Series controls work with DexterLive.com to allow you to create custom programs that fit your business.

A variety of PLUS cycle features and promotion options will help you maximize revenue generation.

INSTALLATION:

A vertical exhaust and vent are standard on every dryer for easy installation. Additional options are available.

The exhaust cleanouts are easy to reach and allow for regular maintenance.

The hinged lower service door makes cleaning the lint screen quick and easy.

OPTIONS:

Available with blue or black graphics, stainless steel or galvanized tumblers, chrome or stainless steel doors, and white or stainless steel panels.

Your dryers can be shipped with coin acceptors or payment system ready.

Gas models, with propane kits available.

This dryer is available as a reversing or non-reversing model.

Dexter C-Series dryers are available in 30lb, 50lb, 80lb and 120lb capacities.

EMPLOYEE OWNED | MADE IN THE USA | SINCE 1894

DEXTER.COM

2211 WEST GRIMES AVENUE, FAIRFIELD, IOWA 52556 USA

1.800.524.2954

T-80 EXPRESS DRYER SPECIFICATIONS

Capacity:

Dry Weight Capacity - lb (kg)	80	(36.3)
Cylinder Volume - cu ft (L)	23	(651.3)

Speed:

Tumbler Speed - RPM	40	---
Motor Size - 60 Hz Models - hp (kW)	1	(0.75)
Motor Size - 50 HZ Models - hp (kW)	0.75	(0.56)
Motor Size - 60 HZ Reversing - hp (kW)	1 & 0.75	(0.75 & 0.56)

Airflow:

60 Hz Model - cfm (M3/min)	1200	(34)
50 Hz Model - cfm (M3/min)	1000	(28.3)

Dimensions:

Cabinet Height - in (cm)	75 3/4	(192.4)
Cabinet Width - in (cm)	38 1/2	(97.8)
Cabinet Depth - in (cm)	51 3/4	(131.4)
Door Opening - in (cm)	25 5/8	(65.1)
Floor to Door Bottom - in (cm)	29 1/4	(74.3)
Cylinder Diameter - in (cm)	36 1/2	(92.7)
Cylinder Depth - in (cm)	38	(96.5)
Lint Screen Area - sq in (sq cm)	823	(5310)

Weight:

Net Weight - lb (kg)	715	(324.3)
----------------------	-----	---------

Shipping Information:

Shipping Weight - lb (kg)	770	(349.3)
Shipping Height - in (cm)	80 3/4	(205.1)
Shipping Width - in (cm)	40 1/4	(102.2)
Shipping Depth - in (cm)	55 1/2	(141)

Gas Requirements (Gas Models Only):

Gas Supply Connection - in (mm)	3/4	(19.1)
Natural Gas Supply (Water Column) - in (cm)	5-8	(12.7 - 20.3)
LP Gas Supply (Water Column) - in (cm)	11 1/2- 13 1/2	(29.2 - 34.3)

Gas Usage (Gas Models Only):

60Hz Model - BTU/hr (kW)	215,000	(63)
50Hz Model - BTU/hr (kW)	195,000	(57.1)

Electrical Requirements:

Gas Models:

Model	Volts / Hz / Phase / Wiring	Circuit Breaker Amps / Running Amps / Wire Size / Reversing
-10	120 / 60 / 1 / 2 wire + ground	15 / 10.4 / #12 / Both Rev & Non-Rev
-39	230 / 50 / 1 / 2 wire + ground	10 / 5.2 / 2.1 mm ² / Non-Reversing
-59	230 / 50 / 1 / 2 wire + ground	10 / 5.2 / 2.1 mm ² / Non-Reversing

Electric Models:

Model	Volts / Hz / Phase / Wiring	Circuit Breaker Amps / Running Amps / Wire Size / Reversing
-79	24 / 400 / 50 / 3 / 4 wire + ground	50 / 45 / 13.3 mm ² / Non-Reversing

Installation Recommendations:

Minimum Clearance Between Machines - in (cm)	0	(0)
Minimum Clearance Behind Machines - in (cm)	18	(45.7)
Make-Up Air Required - sq ft (sq cm)	1.5	(1394)
Exhaust Size - in (cm)	8	(20.3)
Max. Exhaust Back Pressure (Water Column) - in (mm)	0.3	(7.6)
Recommended Exhaust Length - ft (m) & 2 elbows	14	(4.3)

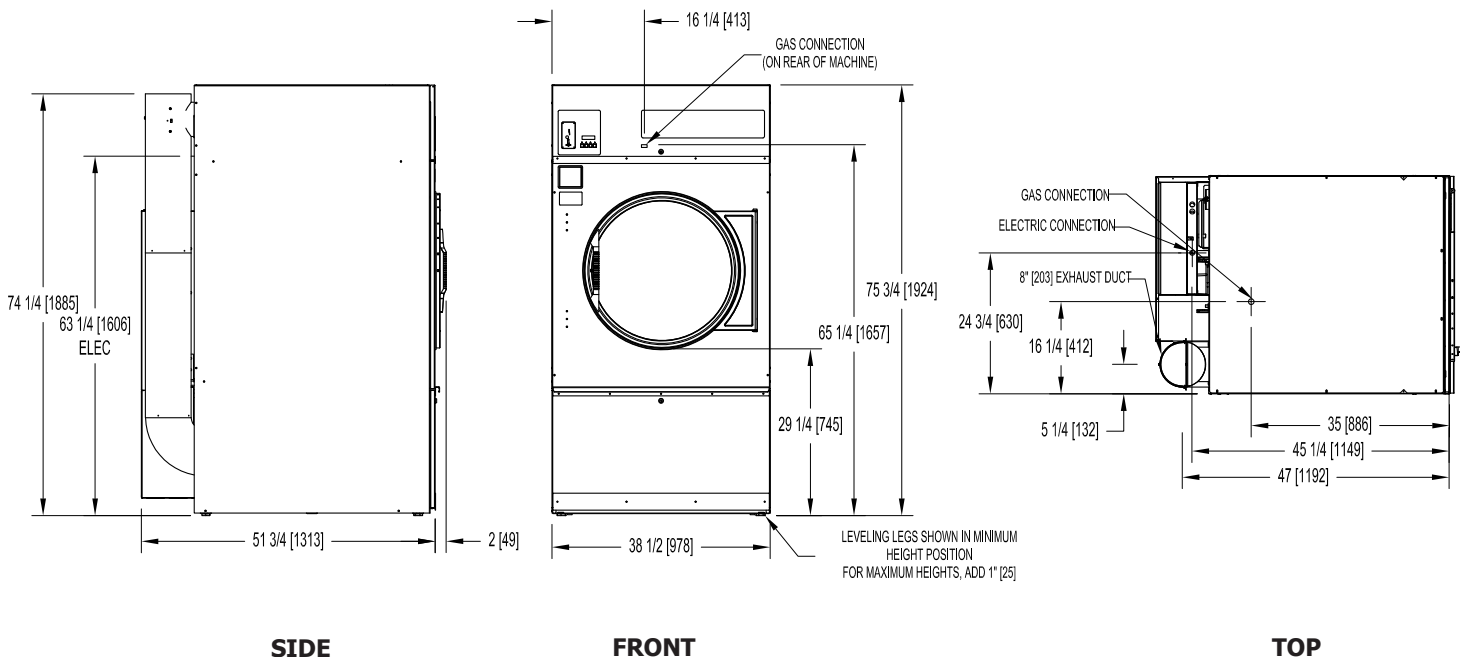

Additional exhaust options are available. Contact your distributor for more information.

Due to continuous product improvements specifications are subject to change, please consult the installation manual for the most accurate information.
 *Agency approvals vary based on machine configuration. Major approval bodies include ETL, CE and AGA. Dexter Laundry is ISO 9001:2015 certified.