



DEXTER[®]
LAUNDRY

**USE THE BLUE TABS LOCATED ON THE
RIGHT AND LEFT SIDES OF THE FOLLOWING
DOCUMENT TO ADVANCE TO EACH SECTION.**











DEXTER
LAUNDRY



O-Series OPL Washers T-350 & T-450 Express Washers 200G

Parts & Service Manual

Equipment Safety Warnings Symbols and Terminology Used in this Equipment

	Indicates an imminently hazardous situation, which if not avoided, will result in death or serious injury.
	Indicates a potentially hazardous situation, which if not avoided could result in death or serious injury.
	Indicates a potentially hazardous situation which, if not avoided, may result in minor or moderate injury. It may also be used to alert against unsafe practices. Minor burns, pinch points that result in bruises and minor chemical irritation.
	Indicates information or a company policy that relates directly or indirectly to the safety of personnel or protection of property.
	This is the user caution symbol. It indicates a condition where damage to the equipment resulting in injury to the operator could occur if operational procedures are not followed. TO REDUCE THE RISK OF DAMAGE OR INJURY , refer to accompanying documents; follow all steps or procedures as instructed.
	This is the electrical hazard symbol. It indicates that there are DANGEROUS HIGH VOLTAGES PRESENT inside the enclosure of this product. TO REDUCE THE RISK OF FIRE OR ELECTRIC SHOCK , do not attempt to open the enclosure or gain access to areas where you are not instructed to do so. REFER SERVICING TO QUALIFIED SERVICE PERSONEL ONLY
	Caution! There are sharp edges on various sheet metal parts internal to the enclosure. Use safety consciousness when placing or moving your hands while working in the interior of this equipment.
	Caution! To reduce the risk of damage to the Water Inlet Valve, do not supply inlet water with a temperature that exceeds 70° C. Caution! To reduce the risk of fire or explosion, do not operate this equipment in any hazardous classified (ATEX) environment.

Equipment Safety Warnings, Symbols, and Terminology Used in this Equipment



Warning! Do not operate equipment if door glass is damaged in any way.



Warning! Keep clear of rotating parts.



Prohibited! Do not enter this equipment or space.



Prohibited! Do not step or stand on this equipment.

Prohibited! Do not operate without all guards and covers in place.



Prohibited! Do not operate without all guards and covers in place.



Prohibited! Do not wash clothing impregnated with flammable liquids (petrochemical).



Prohibited! Do not allow children to play in or around equipment.

	Indicates an imminently hazardous situation, which if not avoided, <u>will result</u> in death or serious injury.
	Indicates a potentially hazardous situation, which if not avoided <u>could result</u> in death or serious injury.
	Indicates a potentially hazardous situation which, if not avoided, <u>may result</u> in minor or moderate injury. It may also be used to alert against unsafe practices. Minor burns, pinch points that result in bruises and minor chemical irritation.
	Indicates information or a company policy that relates directly or indirectly to the safety of personnel or protection of property.
	This is the user caution symbol. It indicates a condition where damage to the equipment resulting in injury to the operator could occur if operational procedures are not followed. TO REDUCE THE RISK OF DAMAGE OR INJURY, refer to accompanying documents; follow all steps or procedures as instructed.
	This is the electrical hazard symbol. It indicates that there are DANGEROUS HIGH VOLTAGES PRESENT inside the enclosure of this product. TO REDUCE THE RISK OF FIRE OR ELECTRIC SHOCK, do not attempt to open the enclosure or gain access to areas where you are not instructed to do so. REFER SERVICING TO QUALIFIED SERVICE PERSONEL ONLY
	Caution! To reduce the risk of fire or explosion, do not operate this equipment in any hazardous classified (ATEX) environment.



WARNING



- All washers must be installed in accordance to all applicable electrical, plumbing and all other local codes.

- These installation and operation instructions are for use by qualified personnel only. To avoid injury and electrical shock, do not perform any servicing other than that contained in the installation and operation instructions, unless qualified.



Do not install washers in an explosive atmosphere.



- Care must be stressed with all foundation work to ensure a stable unit installation, eliminating possibilities of excessive vibration.

- Foundation must be level within 13 mm to ensure proper washer operation.



Do not operate washer if door glass is damaged in any way.



Do not wash clothing impregnated with flammable liquids (petrochemical).



WARNING



Children should be supervised to ensure they do not operate or play in or around equipment.









Keep all panels in place to protect against electrical shock and injury and add rigidity to washer.

This appliance is not intended for use by persons (including children) with reduced physical, sensory or mental capabilities, or lack of experience and knowledge, unless they have been given supervision or instruction concerning use of the appliance by a person responsible for their safety.

A washer should not be allowed to operate if any of the following occur:

- Excessive high water level.
- Machine is not connected to a properly earthed circuit.
- Door does not remain securely locked during the entire cycle.
- Vibration or shaking from an inadequate mounting or foundation

	Warning! Do not operate equipment if door glass is damaged in any way.
	Warning! Keep clear of rotating parts.
	Prohibited! Do not enter this equipment or space.
	Prohibited! Do not step or stand on this equipment.
	Prohibited! Do not operate without all guards and covers in place.
	Prohibited! Do not operate without all guards and covers in place.
	Prohibited! Do not wash clothing impregnated with flammable liquids (petrochemical).
	Prohibited! Do not allow children to play in or around equipment.

	Prohibited! Do not attempt to open, touch, or proceed before referring to the manual or unless qualified.
	Mandatory! Read all supporting documentation before operating or maintaining equipment.
	Mandatory! Disconnect power before servicing equipment.
	Mandatory! Lock out and tag out before servicing this equipment.
	Mandatory! Disconnect water supply before servicing equipment.
	Mandatory! Children should be supervised to ensure they do not operate equipment.

Lined area for notes.

Dexter Safety Guidelines



WARNING

These washers are equipped with devices and features relating to their safe operation. To avoid injury or electrical shock, do not perform and service, unless qualified to do so.

FOR SAFETY

1. Always shut off power and water supply and also discharge capacitors before servicing.
2. Do not overload the washer.
3. Do not attempt to open door if cylinder is in motion or contains water.
4. Do not mechanically force or override door lock in any way.
5. Do not bypass any safety devices of this washer.
6. Do not use volatile or flammable substances in or near this washer.
7. Keep all panels in place. They protect against shock and injury and add rigidity to the washer.

A machine should not be allowed to operated if any of the following occur:

- Excessively high water level.
- Machine is not connected to a properly grounded circuit.
- Loading door does not remain securely locked during the entire cycle.
- Vibration or shaking from an inadequate mounting or foundation.

To activate your warranty, be sure to return your red warranty form to the factory. Please have serial number and model ready when calling for assistance.

Table of Contents

Section 1:

Machine Mounting & Installation

T-350	15
T-450	15
T-350 Installation	16
T-450 Installation	17

Section 2:

Machine Installation & Operating Instructions

Basic Installation.....	20
Electrical Connections & Fusing	
Requirements.....	21-23
Machine Operating Instructions	24
Emergency Stop Button	25
Detergent Measurements by Model.....	26

Section 3:

Machine Programming Instructions

Wash Cycle Programming	30-37
------------------------------	-------

Section 4:

Trouble Shooting

Common Troubleshooting Solutions Pages..	40-42
Troubleshooting Machine Fault Errors.....	44-47
Motor Winding restances.....	47

Section 5:

Machine Service Procedures

Top Panel Removal.....	50
Front Panel Removal	50
Back Panel Removal	50
Drain Valve Access.....	50
Drain Valve Cleaning	50
Detergent Dispenser	50
Vacuum Breaker / Air Gap.....	50
Water Valves	50
Door Lock Assembly Operation	51
Adjustment for the Door Lock Assembly.....	51-52
Adjusting the Loading Door	53
Loading Door Removal	53



Section 1:

Machine Mounting

Specifications for below models are outlined in this book:

T-350	WN0350XA-12E01X	208-240 volts 60hz	Single Phase or Three Phase
T-450	WN0450XA-12E01X	208-240-volts 60hz	Single Phase or Three Phase

T-350 Mounting Pad Dimensions

T-350 INDUSTRIAL WASHER MOUNTING DIMENSIONS

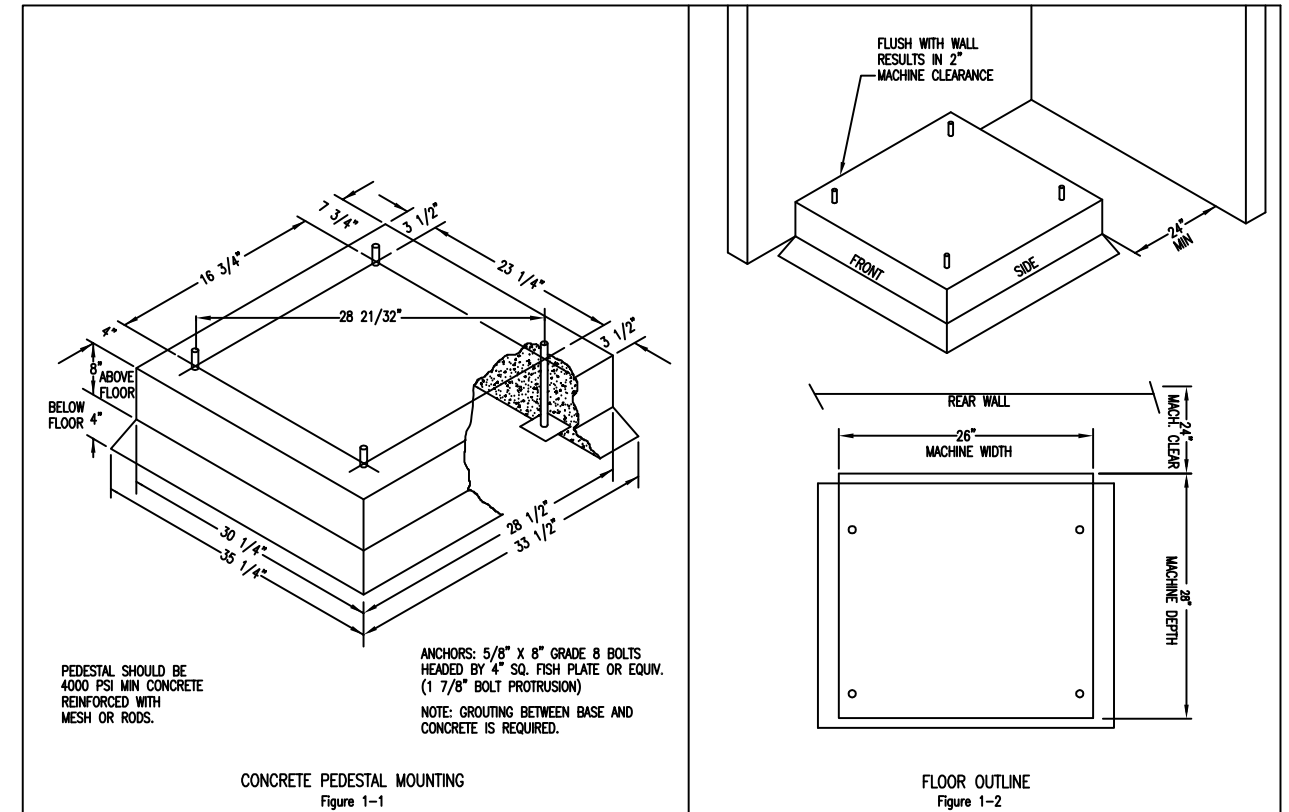
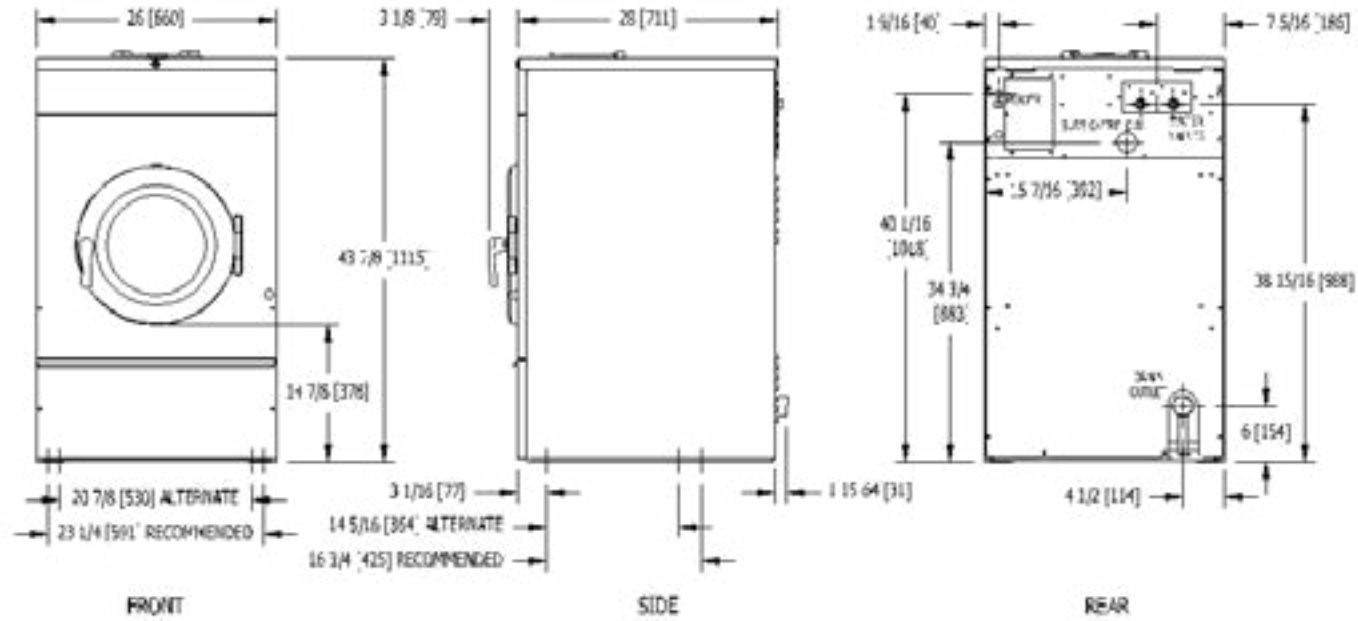

T-450 INDUSTRIAL WASHER MOUNTING DIMENSIONS

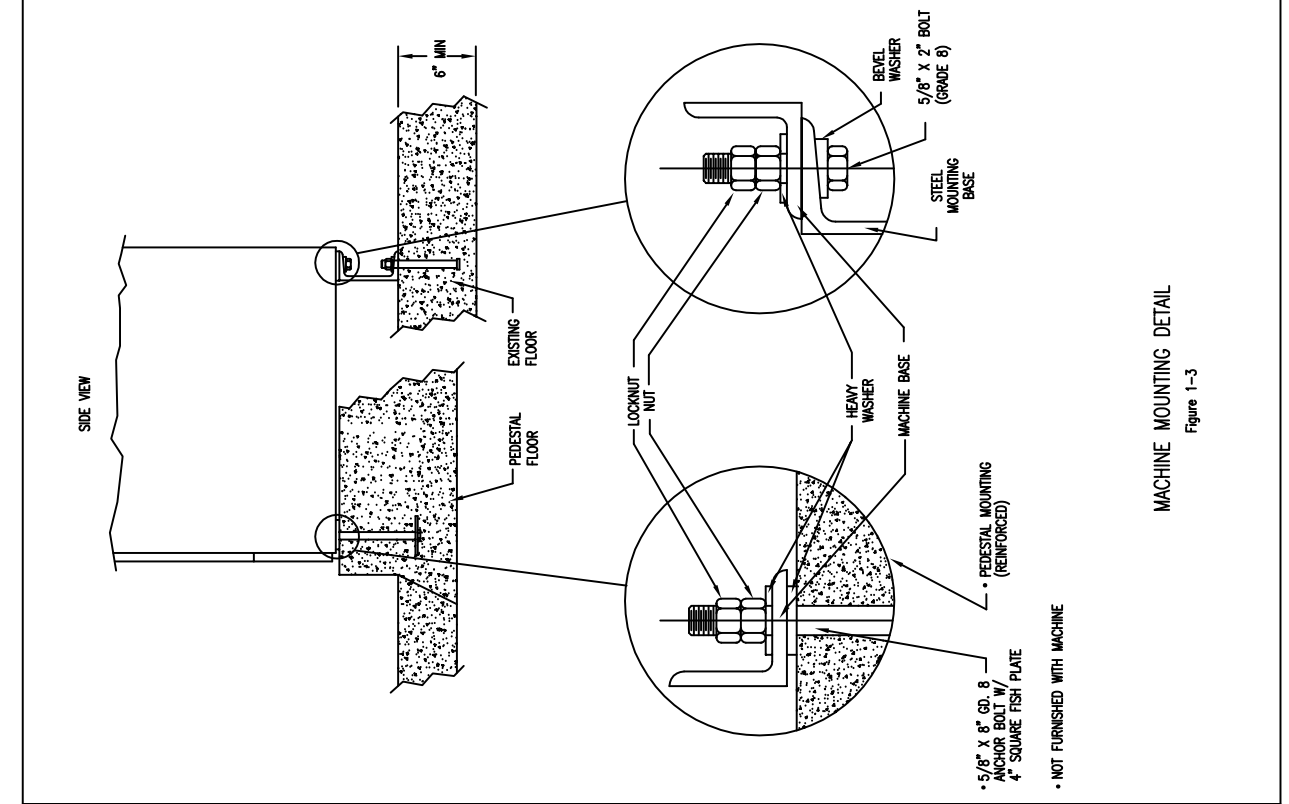
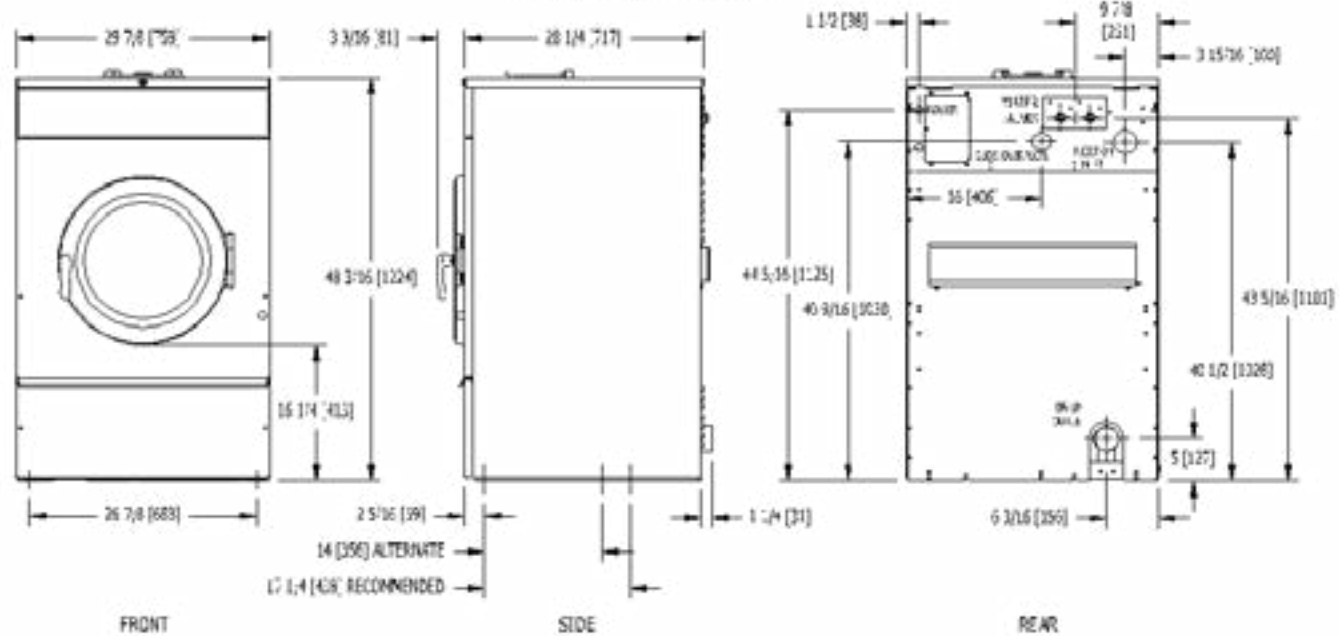



Section 2:

Machine Installation & Operating Instructions

Installation & Operation

All washers must be installed in accordance with all local, state and national building, electrical, and plumbing codes in effect in the area.

Foundation Requirements

This machine is designed for use on or over bare concrete floor - not to be used above combustible flooring, such as carpet or wood. The washer must be securely bolted **and grouted** to a substantial concrete floor, or mounted **and grouted** upon a suitable base that is securely bolted **and grouted** to a substantial concrete floor.

CARE MUST BE TAKEN WITH ALL FOUNDATION WORK TO ENSURE A STABLE UNIT INSTALLATION, ELIMINATING POSSIBILITIES OF EXCESSIVE VIBRATION.

All installations require concrete floors and quality grade anchor bolts or expansion anchors. Mounting hardware is not provided with the machines. Refer to appropriate model Machine Mounting Detail Figures 1-1, 1-2 and 1-3 for floor thickness and bolt sizes. See mounting diagram for overall washer dimensions.

Mounting

A concrete pedestal or steel-mounting base that elevates the machine above the floor level is recommended to provide easy access to the loading door.

Recommended height:

T-350: approximately 8 inches (200 mm)

T-450: approximately 6 inches (152 mm)

Allow a minimum 24 inches (610 mm) of clearance behind the rear of the machine to provide access for motor service. Contact a Dexter laundry equipment distributor for recommended steel mounting bases. If an elevated concrete pedestal is desired, it should be embedded into the existing floor. See Machine Mounting Detail Figures for floor thickness and bolt sizes.

EXPANSION ANCHORS ARE NOT RECOMMENDED FOR USE IN CONCRETE PEDESTALS BECAUSE THE ANCHORS ARE TOO CLOSE TO AN EDGE, CAUSING IT TO BREAK OUT.

Mounting Holes

See mounting dimensions for the machine model you are installing in previous section. They also show a typical concrete pad arrangement. It is highly recommended that you use all mounting holes supplied with each model. Note: Mounting bolts should be checked frequently to insure that they remain tight. The machine should be checked with a spinning load to be sure there is no unusual vibration or movement between the machine and the base or floor. Please note: Machine grouting is highly recommended as grouting insures stability and longevity.

Plumbing

Water supply hoses are provided with each machine. The threaded connections on the hoses are $\frac{3}{4}$ -11 $\frac{1}{2}$ NHT for 60 Hz models and $\frac{3}{4}$ -14 BSP for 50 Hz models.

Separate hot and cold water lines must be supplied to the machine, maintaining 30 psi to 120 psi (207 kPa to 827 kPa) water flow pressure. A 140°F (60°C) hot water supply is recommended for best washing results. Do not exceed 180°F (82°C) water temperature.

Drain

The drain outlet tube size:

For T-350 is 2 $\frac{1}{4}$ inches (57 mm) in diameter,

and for T-450, 650, 750, 950, 1450 is 3 inches (76 mm) in diameter

Any drain hose used must be lower than the drain valve to assure proper draining.

Protective Film

The machine may have protective adhesive film on the front escutcheon area and the front and side stainless steel panels. The film may be peeled off before putting the machine into service.

Electrical

The Dexter single/three-phase 208-240VAC 60 Hz (single phase 230VAC 50 Hz) non-heated washing machines and three phase only 208-240VAC 60 Hz (400VAC 50 Hz) heated washing machines are intended to be permanently installed appliances. No power cord is provided. The machine should be connected to an individual branch circuit not shared by lighting or other equipment. A means for disconnection with a contact separation of at least 1/8" (3 mm) must be provided. The connection should be sheathed in liquid-tight or approved flexible conduit, or equivalent, with conductors of the proper size and insulation (50 Hz: The sheath of the supply cord must be at least equivalent to that of a cord complying with IEC 227 or IEC 245). A qualified technician should make such connections in accordance with the wiring diagram. See specification sheet for minimum recommended wire size.

Individual circuit breakers for each unit are required. Do not use ground-fault (earth-fault) circuit breakers or ground-fault (earth-fault) circuit interrupter outlets.

To Make Electrical Connections

Disconnect all power to the washer.

Remove the top panel of the washer and locate the power terminal block near the back of the control compartment.

If power is 208-240V-3PH-60Hz, connect L1, L2, L3 and Ground. If there is a high leg, it must NOT be connected to L1 or L2. However, failure due to a voltage surge on the high leg is not covered by equipment warranty. Contact Dexter Laundry with any questions.

If power is 208-240V-1PH-60Hz, connect L1, L2 and Ground (Only Non-Heated Washers may be connected to 1PH power).

If power is 400V-3PH-50Hz, connect L1, L2, L3, N, and Earth. If there is a high leg, it must NOT be connected to L1 or L2. However, failure due to a voltage surge on the high leg is not covered by equipment warranty. Contact Dexter Laundry with any questions. (Only Heated Washers may be connected to 400V-3PH power).

If power is 230V-1PH-50Hz, connect L1, N and Earth (Only Non-Heated Washers may be connected to 1PH power).

NOTE: It is important that the grounding screw next to the power terminal block be connected to a good external ground.

Dexter Recommended Connections	Controller / Injector Signals
Detergent	1
Bleach	2
Starch	3
Sour/Softener	4
	5
	6
	7
	8
	9
	10



! WARNING

Always disconnect electrical power to the machine before performing any adjustments or service.

60 HZ CONTROL TRANSFORMER CONNECTIONS

NOTE: transformer must be set at proper tap for proper operation.

The controls transformer is located inside the control trough and steps a range of 208 to 240 volts down to 115 volts and 24 volts. There are two terminals on the controls transformer for the primary (incoming) power. Use the terminal marked "208V" for power supplies between 208 and 219 volts. Use the terminal marked "240V" for power supplies between 220 and 240 volts. Refer to the following for control transformer connections.

CONTROL TRANSFORMER CONNECTIONS

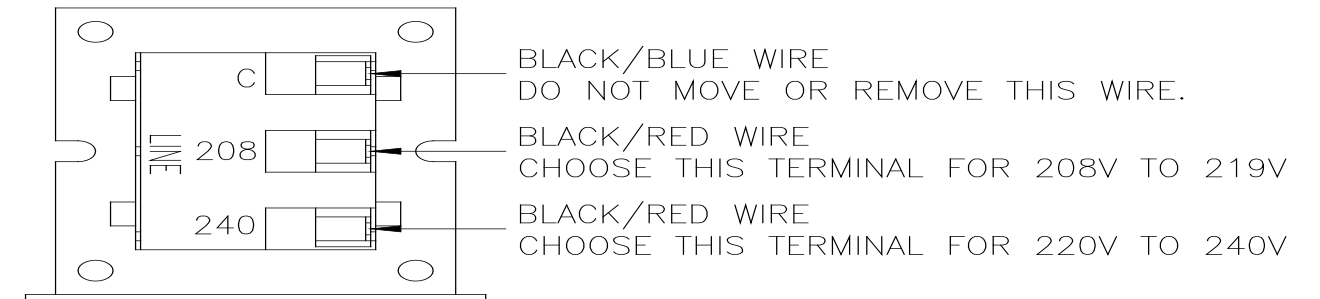

CONTROLS TRANSFORMER (230V 50 Hz models only)

The controls transformer is located inside the control trough and steps a range of 180 to 255 volts down to 24 volts. There are two terminals on the controls transformer for the primary (incoming) power. Use the terminal marked "L1 200V" for power supplies between 180 and 229 volts. Use the terminal marked "L1 230V" for power supplies between 230 and 255 volts.

CONTROL TRANSFORMER CONNECTIONS

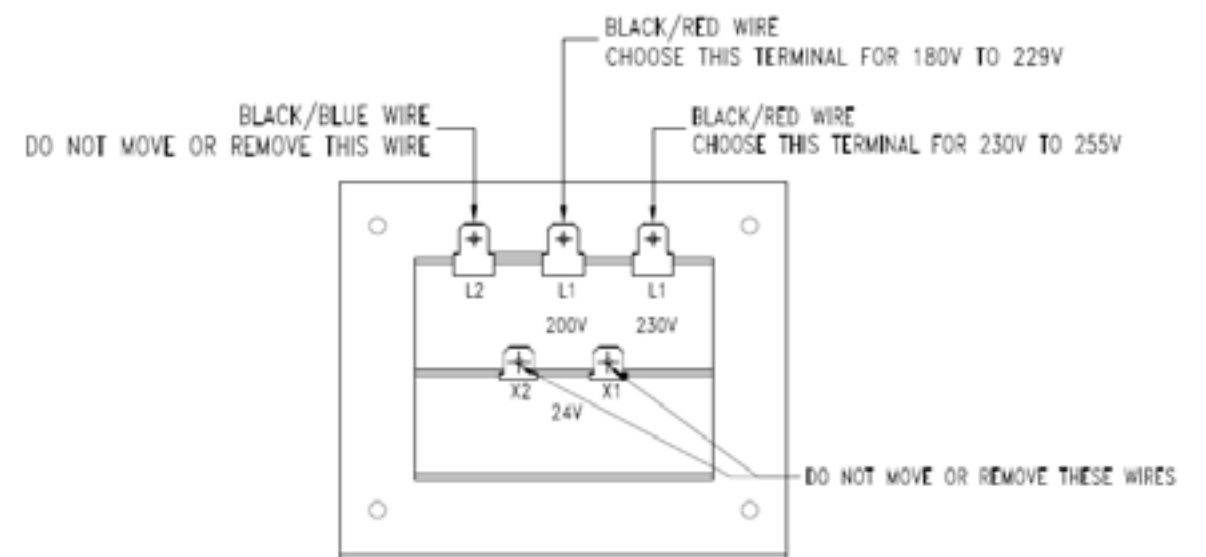

50 Hz Control Transformer Connections

2.11.5 VARIABLE FREQUENCY DRIVE ADJUSTMENTS (208-240V 60 Hz T-950, T-675 and T-1475 models only)

The variable frequency drive allows for varying acceleration during Final Spin on T-950, T-675 and T-1475 models. It is important to utilize a decreased acceleration rate when the application power is low. This acceleration rate is determined by a white wire jumper installed on the drive terminal block from +10V to AVI. Reference the diagram below for terminal block locations.

Remove the wire jumper when input power is between 208 and 219 volts. Keep the jumper installed when input power is between 220 and 240 volts. Reference the drawings below for the jumper location.

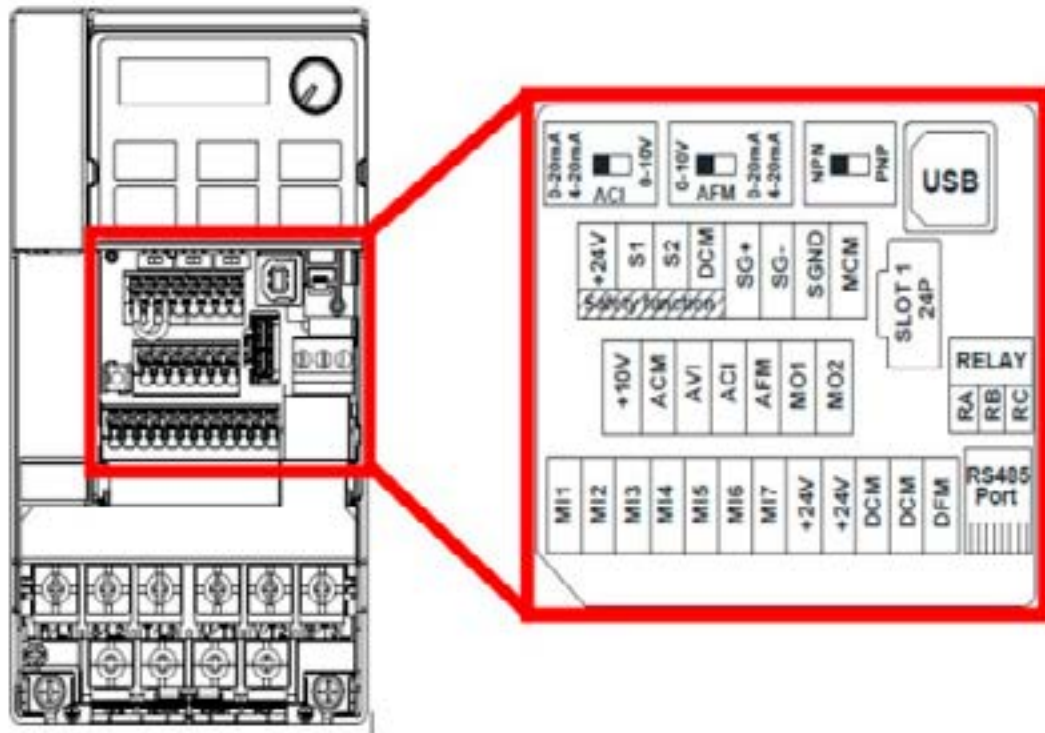

Control Terminations on Variable Frequency Drive

O Series Washer Model	Max Spin Speed	Input Voltage	Jumper Terminal Locations on Variable Frequency Drive (VFD)															
			M11	M12	M13	M14	M15	M16	DCM (Left)	DCM (Right)	74V	ACM	AVI	ACI	10V	MO1		
T-950	200G	240V													X		X	
	200G	208V	No Jumper required															
T-675	300G	240V													X		X	
	300G	208V	No Jumper required															
T-1475	300G	240V													X		X	
	300G	208V	No Jumper required															

INJECTION SOURCE CONNECTIONS

The washer control may be programmed to send ten 120VAC output signals for 60Hz models (or 24VAC for 50Hz) for a chemical injection system. The signals are not intended as a power source and must be limited to less than 100 milliamps of current. There is a separate terminal block for connection of the external injection signals. For the injection sources, program codes 1 through 10 and their respective terminal block connections are as shown in Table 1.

Dexter Recommended Connections	Controller / Injector Signals
Detergent	1
Bleach	2
Starch	3
Sour/Softener	4
	5
	6
	7
	8
	9
	10

Table 1: Injection Signal and Circuit Identification

If required, chemical injection hoses are to be inserted into the injection inlet at the upper right rear of the washer. These hoses should be inserted into the round PVC pipe a distance of:
 For T-450 minimum of 8" (20 cm) and a maximum of 12" (30 cm)
 For T-650, 750, 950 and 1450 a minimum of 14" (36 cm) and a maximum of 18" (46 cm)
 (For T-350 insert hoses into the top soap dish)
 This will eliminate chemical buildup in the pipe and/or restrict water flow to the tub. Secure the hoses as required.

Fusing Requirements:

Dual element time delay fuse or equivalent breaker of amperage specified below.

- 1 Phase or 3 Phase 15 amp , 208-240v
- WN0350-12, WN0450-12.
- WN0350-39 or 59, WN0450-39 or 59.

OPERATION CHECK

During intermediate spin and final spin, the cylinder should turn in a counterclockwise direction when viewed from the front of the machine. If spin is clockwise, the T1 and T2 motor wires connecting to terminal T1 and T2 on the variable frequency drive should be swapped. Remove power to the machine before opening service panels and swapping wires.

OPERATING INSTRUCTIONS

STARTING THE WASHER

1) Turn on power to the washer.

A) Load the laundry.

Place laundry into the cylinder and latch the door securely. Be sure laundry does not get caught between the door gasket and tub front when closing the door. Maximum load is the dry weight capacity listed in the specification sheet. Do not exceed the listed capacity weight.

NOTE: To begin closing the door, the handle must be in the horizontal position. After moving the door to the closed position, the handle must be turned down to the vertical position in order to latch the door for machine operation.

2) Select wash cycle.

Select the appropriate cycle for the type of load being washed. Use the "UP" and "DOWN" keys to change the cycle on the display to the desired cycle and press the enter button to select.

3) Add washing chemicals.

If not using a chemical injection system, add low sudsing powdered detergent into the "DETERGENT" compartment of the automatic dispenser on the top or front of the washer. If liquid wash products are used in the "DETERGENT" compartment, they must be added at the beginning of the wash cycle. If desired, add fabric softener to the "FABRIC-SOFTENER" compartment. Use the amount of fabric softener as recommended by the manufacturer. If the machine is set for pre-wash, washing products can be added to the round opening of the dispenser or put in with the clothes when loading the washing machine. If bleach is desired, DO NOT place into dispenser until the ADD BLEACH message is displayed.

4) Start wash cycle.

Press enter to start the cycle. The display will show cycle information throughout the cycle. The door will lock and remain locked until the end of the cycle. Pause wash cycle / End wash cycle Press the red pause button to pause the cycle. Select Start to restart the cycle or select Cancel Cycle to end the wash cycle.

5) End of cycle

A tone will sound (if programmed) and the display will indicate that the cycle has ended. The door can now be opened. Immediately remove contents of washer. Leave the door open when the machine is not in use.

EMERGENCY STOP / SAFETY DOOR LOCK

This machine is equipped with a safety door lock that locks the door when the cycle is started until the cycle is complete. The door lock prevents opening the door for up to 3 minutes if the power is interrupted during the cycle.

The Emergency Stop button ends the cycle and allows the door to be opened after the Safety Door Lock releases. When the Emergency Stop button is pressed an alarm will sound (if programmed), an "Emergency Stop" message will be displayed, tumbler movement will begin to slow and water will begin draining from inside the washer. Though the machine may end movement quickly, it may take up to 3 minutes for the door to unlock. During that time the alarm will continue to sound. When the alarm stops, the door may be opened. Inspect the washer as needed and reset the emergency stop button by turning it clockwise. Reset the washer by selecting Cancel. The washer may be restarted by closing and latching the door, and starting a new cycle.

VARIABLE FREQUENCY DRIVE INDICATORS

There are three small red LEDs located on the upper Variable Frequency Drive (VFD) cover. They are labeled as "READY", "RUN", and "FAULT" and can be used for troubleshooting. The definitions of the LEDs are listed in Table 2 below.

Washer Condition	"READY" LED Status	"RUN" LED Status	"FAULT" LED Status
Idle Mode (No Cylinder Movement)	ON	OFF	OFF
Tumbling	ON	ON	OFF
Stop from Tumble	ON	FLASHING	OFF
Ramp to Intermediate or Final Extract Spin	ON	ON	OFF
Spinning (Intermediate or Final)	ON	ON	OFF
Stop from Spin (Intermediate or Final)	ON	FLASHING	OFF
Faulted	ON	OFF	ON



Injection Source Details

The washer control may be programmed to send output signals for a chemical injection system. There is a separate terminal block for connection of the external injection signals. For the injection sources, program codes 0 through 6 are as shown in the table below. Injection signal will trigger a 120 volt reading at rear terminal block for approximately 5-10 seconds and will start to trigger at about 10-15 seconds after start of fill bath. (Chemical Injection Signals are shown in the programming section.)

Detergent Measurements By Washer Model



Triple Load T-350 Washer



Mega Load T-450 Washer

TRANSIENT VOLTAGE SURGE SUPPRESSORS

Like most electrical equipment your new machine can be damaged or have its life shortened by voltage surges due to lightning strikes which are not covered by factory warranty. Local power distribution problems also can be detrimental to the life of electrical components. We recommend the installation of transient voltage surge suppressors for your new equipment. These devices may be placed at the power supply panel for the complete installation and don't require an individual device for each machine.

These surge protectors help to protect equipment from large spikes and also from small ongoing spikes in the power that occur on a day to day basis. These smaller surges can shorten overall life of electrical components of all types and cause their failure at a later date. Although they can't protect against all events, these protective devices have a good reputation for significantly lengthening the useful life of electronic components.

Electronic Components are helped to have a longer useful life when they are supplied with the clean stable electrical power they like.

Notes

Blank lined area for taking notes.

O-SERIES WASHERS PROGRAMMING WITH DEXTERLIVE



Our O-Series washers are simple and easy to program with DexterLive.com. This guide will provide an overview of some of the features DexterLive offers and how to create the cycles that fit your location's specific needs.

Set-Up an Account and Location

If you don't already have a DexterLive account, it is easy to register at DexterLive.com.

Once you have an account, you can create a new location and customize that location based on a specific application. Simply select on-premise laundry as your location type and the application type option will be available.

Tip: If you have multiple applications, you can provide a generic name (e.g., Motel) and use the same custom programs across multiple locations.

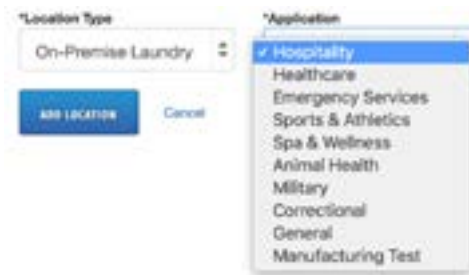

Add Equipment

Before programming cycles, you need to add equipment. Because functionality differs between model types, it is important to select the right model. You can name your machine, input the serial number, and add the DexterLive ID if you choose. However, this information is not required.

Tip: To create a generic program to be used in many locations, leave the serial number and DexterLive ID blank.

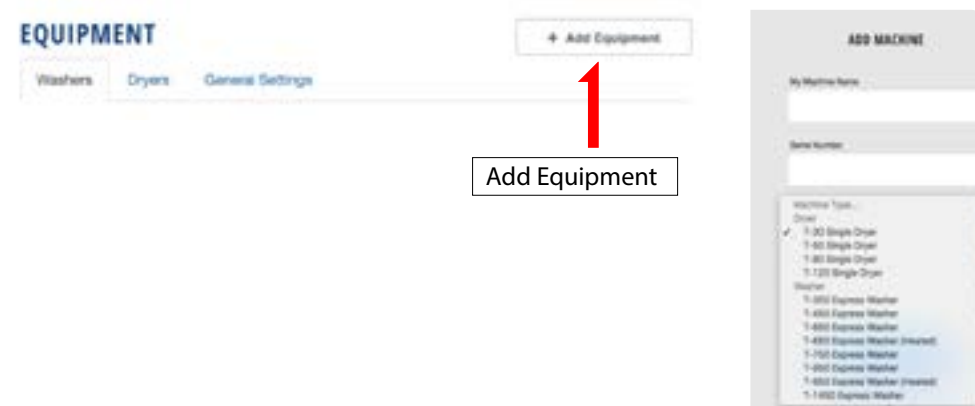

General Settings

General settings will set the global parameters for your location. These parameters will impact all washers and dryers added to that location.



Setting	Options	Notes
Machine Display Language	Multiple	Changes the language of cycles, stages, and prompts that are displayed on the control. Individual cycles can still be set for different languages.
End of Cycle Sound	On / Off	Buzzer will sound when cycle is complete.
Button Sound	On / Off	Audible feedback when buttons are pressed.
Display Temperature	°F / °C	Choose between Fahrenheit or Celsius.
Passcode	0000 – 9999	Select a code for management screen access
View Non-Critical Errors	On / Off	Will display errors such as Slow Fill / Slow Drain during cycle. If OFF, these errors will still register in the cycle log, but will not be shown on the display.
Time Format	12 hr / 24 hr	Changes how time is displayed on the control.

Machine Settings

Most programming functions are available under the individual machine settings. Under this selection, you can review, edit, create, or delete cycles as well as select injection types and customize tumble speeds.



Cycles

The cycle page allows you to add, edit, copy, delete, or reorder cycles.

	CYCLE NAME	TOTAL TIME	MAX FILL TEMP	MAX TUMBLE MODE	
Cycle 1	White Sheets	27 min	Hot	Normal	≡ ☰ 🗑️
Cycle 2	Color Sheets	22 min	Warm	Normal	≡ ☰ 🗑️
Cycle 3	White Towels	28 min	Hot	Normal	≡ ☰ 🗑️
Cycle 4	Color Towels	23 min	Warm	Normal	≡ ☰ 🗑️
Cycle 5	Blankets	23 min	Warm	Normal	≡ ☰ 🗑️
Cycle 6	Delicates	23 min	Warm	Delicate	≡ ☰ 🗑️
Cycle 7	Hats & Mops	35 min	Hot	Normal	≡ ☰ 🗑️
Cycle 8	Uniforms	29 min	Hot	Normal	≡ ☰ 🗑️
Cycle 9	Stain Treatment	60 min	Hot	Normal	≡ ☰ 🗑️
Cycle 10	White Linens	33 min	Hot	Normal	≡ ☰ 🗑️
Cycle 11	Colored Linens	32 min	Hot	Normal	≡ ☰ 🗑️
Cycle 12	White Uniforms	36 min	Hot	Normal	≡ ☰ 🗑️

+ Add Cycles

Legend

	Edit Cycle	Select anywhere on the cycle description (cycle name, target temp, material, or target) to open the cycle details for editing.
≡	Reorder Cycle	Select and hold to move a cycle up or down in the listing. This will change the order it is displayed on the control.
📄	Copy Cycle	This will duplicate the cycle. Tip: It is easiest to edit an existing cycle instead of creating a new cycle. Copy the cycle that is closest to the cycle you want to create and edit that cycle. If a default cycle doesn't meet your needs, select "Add Cycle" and choose a default cycle from another application. You can always change the cycle name in the edit section.
🗑️	Delete Cycle	This will delete an existing cycle.
+ Add Cycles	Add Cycle	This will allow you to add a preset cycle from another industry or another location.

Cycle Settings

A cycle can be edited by clicking on the cycle name in the Cycles page. The name and language can be customized for that specific cycle. Changing the language for a cycle will change the status, stage names, and prompts displayed during that particular cycle.

Cycle 1 - White Sheets Settings

Cycle Name: White Sheets

Language: English

Tip: If a location has multi-lingual employees, the same cycle can be duplicated and programmed for different languages. For example, in a location with English and Spanish speaking employees, program White Sheets to the desired settings. Copy that cycle, set that cycle language to Spanish, and note the name change to Sabanas Blancas. This will allow all employees to read the necessary prompts and descriptions on the control.

Stages

A stage can also be considered a bath, such as prewash, wash, rinse, etc. Each cycle can consist of 20 unique stages. Within each stage, the following parameters can be selected.

Setting	Options	Options	Description
Fill	Bath Temperature	Hot Warm Cold No Fill	
	Auxiliary Temperature (Heated Models Only)	No Heat 100F (38C) – 195F (91C)	Heated models only. Temperature is programmable in 5 °F / 3° C increments.
	Water Level	Low High	These settings can be controlled by the electronic pressure sensor.
Soap / Chemicals	Injection Type 1 – 3	None Detergent Flush Softener Flush Chemical 1-10	Three unique soap options are available for each stage. See optional settings for setting chemical injection details.
	Injection Delay	0 – 150 seconds	If Delay Fill is ON this is the time from when the low water level is met. If Delay Fill is OFF this represents the time from start of the stage to when chemical injection begins.
	Injection Duration	1 – 240 seconds	The amount of time chemicals will be injected.

Bath	Soak Time	0 – 60 minutes	Time from when fill is complete to when agitation begins.
	Agitation Time	0 – 30 minutes	Time load will tumble.
	Agitation Type	Normal Delicate Custom 1-3	Aggressiveness of the tumble action. Tip: For wet clean or super-delicate applications, create your own custom agitation type in the optional settings.
Drain	Drain Method	Standard None	Tip: Select None for a soak longer than 60 minutes
Spin	Spin Time	0-30 minutes	Amount of time in spin mode.
	Spin Speed	60 – 200G	Spin time must be selected to set spin speed. Speed is programmable in 20G increments.

Continue adding or editing stages as appropriate to create the specific cycle you want. Remember, you have the ability to customize all 20 stages, so get creative and gain Total Control over your laundry experience.

Tip: See example below illustrating how stages can be customized to create a specialty cycle, such as an extended soak.

Example - Extended Soak:

Parameter	Stage 1: Prewash	Stage 2: Soak	Stage 3: Soak	Stage 4: Soak / Wash	Stage 5: Rinse	Stage 6: Final Rinse
Temperature	Cold	Cold	NA	NA	Cold	Cold
Water Level	High	High	High	High	High	High
Soap	None	Chemical 1, 2 & 3	None	None	Chemical 4	Chemical 5
Soak Time	0 mins	60 mins	60 mins	15 mins	0 mins	0 mins
Agitate Time	5 mins	0 mins	0 mins	30 mins	15 mins	15 mins
Agitation Type	Normal	NA	NA	Normal	Normal	Normal
Drain Method	Standard	None	None	Standard	Standard	Standard
Spin Time	NA	NA	NA	2 mins	5 mins	5 mins
Spin Speed	NA	NA	NA	200G	100 G	200G

Optional Settings

These settings will only apply to that specific model type. For instance, optional settings for the T-950 will not apply to a T-650. These will need to be set individually by model.



Custom Agitation

DexterLive has the ability to create 3 custom agitation types. These custom agitations will enable you to create cycles such as a wet clean cycle with “rocking” methods versus a true tumble agitation.

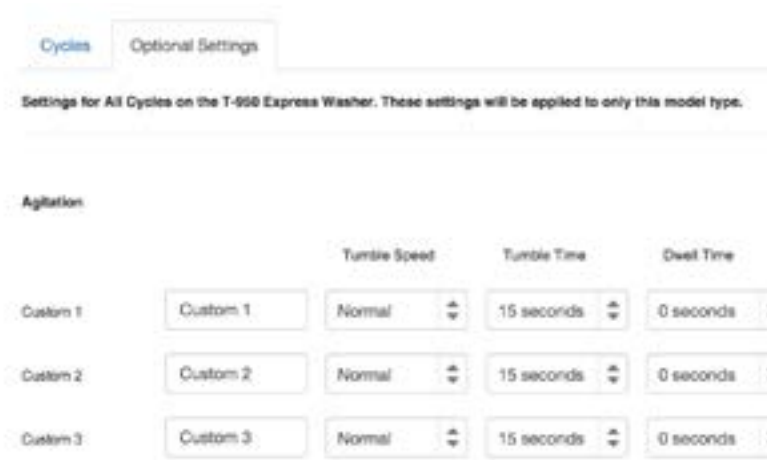

Settings	Options		Notes
		Normal (G / RPM)	Delicate (G / RPM)
Tumble Speed	T-350	0.9 / 55	0.6 / 47
	T-450	0.9 / 50	0.6 / 41
	T-650	0.9 / 50	0.6 / 41
	T-750	0.9 / 43	0.6 / 36
	T-950	0.9 / 43	0.6 / 33
	T-1450	0.9 / 39	0.6 / 32
	Tumble Time	1 – 60 seconds	
Dwell Time	0 – 60 seconds		Controls the length of pause between tumbler action. Tip: By selecting a long dwell time, you allow items to “settle” before restarting the tumbler action.

Tip: See example below for how a custom agitation can be used to create a wet clean cycle.

Example: Wet Clean

Agitation

Custom 1 Wet Clean Delicate 6 seconds 10 seconds

Tumble Speed Tumble Time Dwell Time

Parameter	Stage 1: Prewash	Stage 2: Soak	Stage 3: Soak	Stage 4: Soak / Wash	Stage 5: Rinse	Stage 6: Final Rinse
Temperature	Cold	Cold	NA	NA	Cold	Cold
Water Level	Low	High	High	High	High	High
Soap	None	Chemical 1	None	None	Chemical 5	Chemical 6
Soak Time	0 mins	10 mins	10 mins	10 mins	5 mins	5 mins
Agitate Time	2 mins	2 mins	2 mins	2 mins	2 mins	2 mins
Agitation Type	Wet Clean	Wet Clean	Wet Clean	Wet Clean	Wet Clean	Wet Clean
Drain Method	Standard	None	None	Standard	Standard	Standard
Spin Time	0 mins	NA	NA	0 mins	2 mins	2 mins
Spin Speed	NA	NA	NA	NA	60 G	100 G

Injection Source Names

Name specific injection sources to clearly show which chemical is being used in which stage or cycle.

Delay Fill

With Delay Fill on, the stage does not begin decrementing time until the water level is met. This ensures the load soaks or agitates the target time, even in cases of low water pressure and slow fills. The default settings have Delay Fill turned ON.

Delay Spin

Delay Spin can be set to OFF or up to 150 seconds. Delay Spin can be used in slow drain situations to reduce nuisance Slow Drain error codes. The default settings have Delay Spin turned OFF.

Programming

Once all cycles are set, the programming file (called userconfig.xml) can be downloaded following the instructions on the programming tab DexterLive.com.

At the machine, you can enter management view by pressing up on the idle screen.



Simply insert the USB, scroll to Import User Data, and begin using your customized washer cycles.



Notes

2.11.5 MAXIMUM SPIN SPEED ADJUSTMENT (All washers except T-950)

If desired, the washer can be adjusted to limit the maximum extract spin speed for all wash cycles.

To make this adjustment, a jumper wire must either be installed or removed on the Variable Frequency Drive (VFD), depending on the washer model and desired speed. This Dexter jumper part number 8220-057-036 (qty 1) is factory supplied on terminal points "10V" and "RC". Remove this jumper to make new jumper connections if necessary. Refer to figure below for the approximate location of the control terminations on the Variable Frequency Drive (VFD) and for appropriate jumper connection points indicated with an "X" for the desired maximum spin speed setting. If no adjustment to the default spin speed is desired, do not remove or add any wires on VFD.

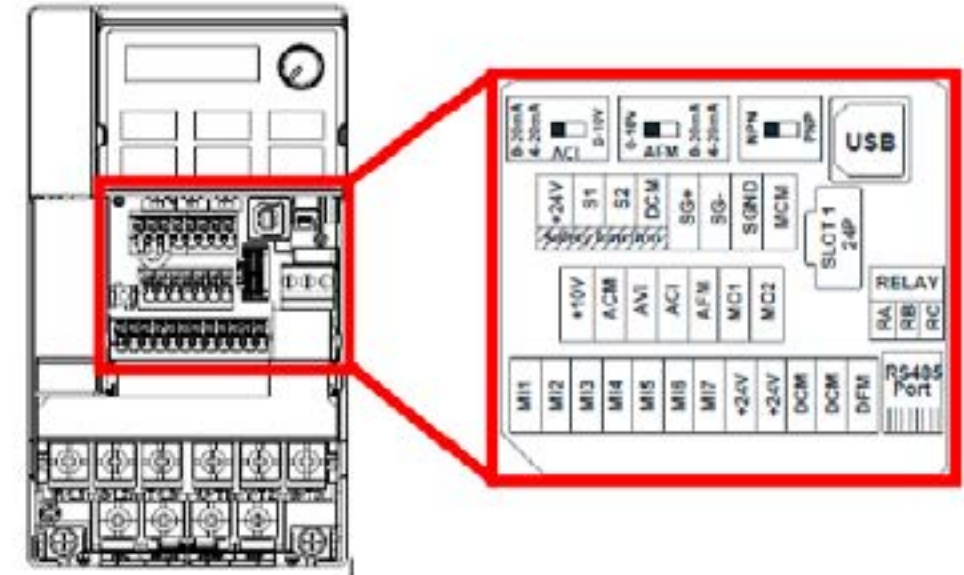

Control Terminations on Variable Frequency Drive

V Series Washer Model	Max Spin Speed	Jumper Terminal Locations on Variable Frequency Drive (VFD)													
		MI1	MI2	MI3	MI4	MI5	MI6	DCM (Left)	DCM (Right)	24V	ACM	AV1	ACI	10V	M01
T-300, T-400,	60 G							X					X		
T-600, T-900,	80 G				X			X							
T-1200	100 G	Default Setting (No Jumper Required)													
T-350, T-450, T-750	60 G												X		X
	100 G				X			X							
	140 G					X		X							
T-650, T-1450	200 G	Default Setting (No Jumper Required)													
	100 G												X		X
	140 G	REMOVE Brown Jumper Between MI5/M01													
	200 G	Default Setting (No Jumper Required)													

Spin Speed Adjustment Jumper Locations

MAXIMUM SPIN SPEED ADJUSTMENT (T-950 Only)

The variable frequency drive allows for varying acceleration during Final Spin on T-950 models. It is important to utilize a decreased acceleration rate when the application power is low. This acceleration rate is determined by a white wire jumper installed on the drive terminal block from +10V to AVI.

Remove the wire jumper when input power is between 208 and 219 volts. Keep the jumper installed when input power is between 220 and 240 volts. Reference the drawing below for the jumper location.

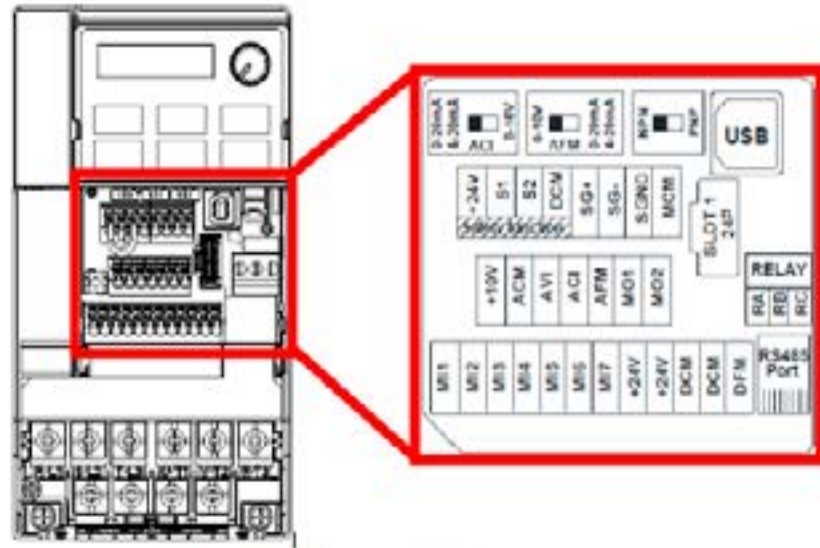

Control Terminations on Variable Frequency Drive

V Series Washer Model	Input Voltage	Max Spin Speed	Jumper Terminal Locations on Variable Frequency Drive (VFD)												
			MI1	MI2	MI3	MI4	MI5	MI6	DCM (Left)	DCM (Right)	24V	ACM	AVI	ACI	10V
T-950	240V	140 G	REMOVE Brown Jumper Between MI5/MO1												
		200G											X		X
	208V	140 G	REMOVE Brown Jumper Between MI5/MO1												
		200G	No Jumper required												

T-950 Spin Speed Adjustment Jumper Locations



Section 4:

Trouble Shooting

Common Troubleshooting Solutions

Symptom	Probable Cause	Suggested Remedy
Machine does not start	Power Supply	Check these areas: Circuit breakers, Voltage, Power leads, Power connections. Is front display LED display lit?
	Door Switch	Check for continuity through door switch when door is closed. If no continuity, adjust or replace door switch.
	Control Breaker or Fuse	Check the 1.5 amp and 2.0 amp fuses (60 hz models) or circuit breaker (50 hz models) for continuity. If no continuity, replace fuse or breaker.
	Control Transformer	Check voltage output from control transformer for 24 VAC and 120VAC (50 hz models have 24 VAC only). If voltage is incorrect, check for proper transformer tap connection or replace transformer.
	Check PCB board	Check all wire connections for sure contacts.
	Check wiring between PCB	Check data cable phone type connectors unplug and VFD and replug with power removed.
	Check Door Lock Mechanism	Check that 120 VAC power (for 60 hz) or 24 VAC power (for 50 hz) is at door lock motor after start button is pressed.
Door does not lock	Check display for fault code	Follow tests described in fault code section.
	Door locking mechanism	Check to ensure that mechanism is receiving 120VAC for 60 Hz. models (or 24VAC for 50 Hz. models) from main relay PCB. If it is receiving power but not functioning, then replace mechanism.
	Door Switch	Check for continuity through door latch switch when door closed. If no continuity, adjust or replace door switch.
Door will not open	Thermoactuator	Check to see if thermoactuator(s) and/or its mechanism is stuck or binding and not allowing the door lock mechanism to open. Check to be sure that the locking thermoactuator is not receiving 24VAC during the last 1 1/2 minutes of the cycle. Also check to see that the unlocking thermoactuator is receiving 24VAC during the last minute of the cycle. If the timing and voltage are correct, replace the thermoactuator.
	Door Rod	Check to see that door rod from solenoid to lock ass'y is long enough to allow lock ass'y to disengage. If not, adjust rod.
Door will not open	Door locking mechanism	Check that door lock mechanism is not stuck closed. If stuck, replace.
	Door Rod	Check to see that door rod from solenoid to lock ass'y is long enough to allow lock ass'y to disengage. If not, adjust rod.
No hot water in detergent dispenser	Water Valve Coil	Check coil continuity at terminals and replace if no continuity. 120 VAC power (60Hz) only on for 20 second in wash bath. (24 VAC for 50 Hz models)
	Water Inlet	Check water inlet screens for blockage and clean screens if necessary.
	Water	Check to insure that water is turned on and operating.
	P-20 Wire Harness	Check black & white harness.

Symptom	Probable Cause	Suggested Remedy
Hot water does not enter tub in wash	Water Valve Coil	Check coil continuity at terminals and replace if no continuity. Check for 120 VAC power (60 Hz) from main relay PCB. (24 VAC for 50 Hz models)
	Water Inlet	Check water inlet screens for blockage and clean if necessary screens
	Water	Check to insure that water is turned on and operating.
	Check Voltage	If appropriate voltage is not present at the valve, refer to the wiring diagram for your specific washer model. Check for voltage at the P4 Connector on the Relay PCB. Check for LED indication that the appropriate relay is activated.
	Pressure Switch	Check pressure switch continuity between terminals . If no continuity, check pressure switch hose for obstruction. If hose okay, change pressure switch.
No cold water to tub in wash	Water Valve Coil	Check coil continuity at terminals and replace if no continuity.
	Water Inlet Screens	Check water inlet screens for blockage and clean if necessary.
	Water	Check to insure that water is turned on and operating.
	Check Voltage	If appropriate voltage is not present at the valve, refer to the wiring diagram for your specific washer model. Check for voltage at the P4 Connector on the Relay PCB. Check for LED indication that the appropriate relay is activated.
	Pressure Switch	Check pressure switch continuity between terminal contacts. If no continuity, check pressure switch hose for obstruction. If hose okay, change pressure switch.
Water comes in but level does not rise	Drain Valve (open)	Check these areas: <ul style="list-style-type: none"> • Drain valve blockage • Drain valve motor and gear train. If power but drain valve does not close, replace valve. • Power to the drain valve. If no power to drain valve, check circuit for power.
	Check Voltage	If appropriate voltage is not present at the valve, refer to the wiring diagram for your specific washer model. Check for voltage at the P4 Connector on the Relay PCB. Check for LED indication that the appropriate relay is activated.
Water does not flush softener compartment.	Water Valve Coil	Check coil continuity at terminals and replace if no continuity.
	Water Inlet Screens	Check water inlet screens for blockage and clean if necessary.
	Water	Check to insure that water is turned on and operating.
Water does not flush softener compartment.	Pressure Switch	Check pressure switch continuity between terminals. If no continuity, check pressure switch hose for obstruction. If hose okay, change pressure switch.
Water level too high	Pressure Switch	Check for blockage in pressure switch hose. Check for pressure switch opening circuit across terminals . Replace switch if contacts do not open.
Water drains slowly	Drain System	Check hoses and drain valve for blockage. Clean of inadequate size. if necessary. Check building drains for blockage

Fault#	Description	Customer Action
HEAT_RISE_OUT_OF_RANGE	Operating temperature is above (target temperature + upper hysteresis) and above 220F (104C)	Check operating thermistor
NO_HEAT_RISE	Operating temperature is below (target temperature + lower hysteresis) and operating temperature has not increased by 2F in 15 minutes	Check operating thermistor Check gas Check combustion
PROX_SENSOR_OUT_OF_RANGE	This error occurs when the machine control sees output from the proximity sensor(s) that does not fall in the acceptable range for the particular washer or dryer model running at normal speeds. It also occurs when the machine control sees output from the proximity sensor that implies the tumbler is still turning when the control has commanded it to Stop.	The machine will not start and the Error Code will continue to be displayed until the prompt is followed to Reset the Error Code and return the Machine to Idle Mode.
NO_PROX_SENSOR_OUTPUT	The RPM is below 10 after the VFD is within 10% of its commanded frequency for 3 seconds	Check belts Check Prox Sensors
BL_COMMAND_ERROR	The control board received a bootloader command but was unable to complete the operation requested	Hold reset button for 10 seconds to force control board into the actual bootloader.
THERMISTOR_SHORT	There is a short circuit across the thermistor terminals or the measured temperature is above 385 degrees F (below 100 ohms).	Check Thermistor connections Check Thermistor resistance
THERMISTOR_OPEN	There is an open circuit across the thermistor terminals or the measured temperature is below -33 degrees F (above 310 Mohms)	Check Thermistor connections Check Thermistor resistance
OH_THERMISTOR_SHORT	There is a short circuit across the thermistor terminals or the measured temperature is above 440 degrees F (below 50 ohms).	Check OH Thermistor connections Check OH Thermistor resistance

Fault#	Description	Customer Action
OH_THERMISTOR_OPEN	There is an open circuit across the OH thermistor terminals or the measured temperature is below -33 degrees F (above 310 Mohms)	Check OH Thermistor connections Check OH Thermistor resistance
DRIVE_COMMUNICATION_ERROR	Failure to reset VFD, communication retry failure over 3 times	Check VFD cable Check VFD power
DRIVE_CRC_MISMATCH_ERR	CRC mismatch in VFD message	Check VFD FW Check VFD cable Check for noise on VFD cable
DRIVE_ENABLE_ERROR	VFD speed still 0 after commanding frequency 3 times	Check VFD enable relay Check VFD enable connector Check VFD enable cable
DRIVE_EXCEPTION_ERROR	Exception received from VFD	Refer to Graphics board for specific exception
SLOW_SPIN_ERROR	VFD frequency is not within 10% of the command frequency after time specified by acceleration type	Check VFD load
DRIVE_RESETTING	Tempory warning indicating that the drive was commanded to reset	Check VFD FW Check VFD cable Check for noise on VFD cable
DRIVE_RESET_COMPLETE	Warning used to indicate a VFD reset was successful	No Action Required
MODEL_DRIVE_SIZE_ERROR	VFD size does not match machine configuration parameters	Check model header Check model configuration
DRIVE_PARAMETER_ERROR	VFD parameters not match machine configuration parameters	Check model header Check model configuration
NON_DEXTER_DRIVE	Failed to validate Dexter Drive	Check VFD model
SPIN_TIME_ERROR	VFD frequency is not 0 after time specified by deceleration type	Check VFD Check Drum
VFD_FAULT	Fault detected on VFD	Check Graphics board for which fault
VFD_HARD_ERROR	Unknown error returned from the VFD	Check VFD
VFD_RESET_FAIL	Failed to reset the VFD	Check VFD

Fault#	Description	Customer Action
PORT_EXP_INIT	Could not initialize port expander(s)	Check I2C connections
PORT_EXP_READ	Could not read port expander	Check I2C connections
PORT_EXP_SET	Could not set output on port expander	Check I2C connections
PORT_EXP_OLAT	Could not latch output on port expander	Check I2C connections Check voltage on output pins of port expander
PORT_EXP_BAD_CONTROL	Control register mismatch on port expander or issue writing to control register	Verify Relay board was not reset without control board
PORT_EXP_FAILURE	Output register mismatch on port expander	Verify Relay board was not reset without control board
MODEL_CONN	Model connector missing or invalid	Check model connector
OVERHEAT_ERROR	Overheat condition detected	Check Overheat thermistor Check operating temperature thermistor
POWER_LOSS_ERROR	Power loss condition detected	Check power cable Check power to control board
SLOW_FILL_ERROR	Water level has not reached desired level when filling for 15 minutes	Check water supply Check water valves Check water valve relays Check pressure sensor

Fault#	Description	Customer Action
SLOW_DRAIN_ERROR	Water level has not reached empty level when draining for 5 minutes	Check water drain Check drain valve Check drain valve relay Check pressure sensor
INVALID_FILL	Fill type specified does not match available types	Contact software engineering. Indicative of software bug or processor malfunction
DOOR_SHUT_NOT_LOCKED	Unable to lock door when starting washer cycle. Unable to keep door locked when running a cycle	Check door lock motor Check door lock relay Check thermoactuators
INCOMPATIBLE_SPIN_SPEED	Spin type specified does not match available types	Potential model mismatch between control board and graphics board, reset machine.
THERMAL_LOCK_FAIL	Unable to hold the door locked when testing between stages	Check thermoactuators
E_STOP	Emergency Stop button depressed	Check E-stop button

20lb O-Series Express Washer

Motor	Winding	Wire #	Resistance	
			Minimum	Maximum
60lb 1ph or 3ph 60hzMain (wash & spin)		T1 & T2	3.71	4.09
Dexter #9376-307-001		T2 & T3	3.71	4.09
Marathon #		T1 & T3	3.71	4.09

30lb O-Series Express Washer

Motor	Winding	Wire #	Resistance	
			Minimum	Maximum
60lb 1ph or 3ph 60hzMain (wash & spin)		T1 & T2	2.45	2.71
Dexter #9376-319-001		T2 & T3	2.45	2.71
Marathon #		T1 & T3	2.45	2.71

NOTE: Resistance values are measured at the stator. Values at the end of the motor wiring harness may be slightly higher.

Top Panel Removal

- Step 1:** Remove 4 screws that hold detergent dispenser to top panel.
- Step 2:** Unlock top panel lock.
- Step 3:** Raise top panel, slide to the rear to release from back clips and lift off.

Front Panel Removal

- Step 1:** Remove 2 screws between front panel top and front (located behind control panel).
- Step 2:** Remove the two screws in the middle of the front panel.
- Step 3:** Pull panel out at the bottom to about a 45 degree angle to detach the top lip and remove.

Back Panel Removal

- Step 1:** Remove all screws holding back panel in position except the bottom row.
- Step 2:** The bottom row of screws are slotted and only need to be loosened and to lift off panel.

NOTE: The back panel is not only a safety requirement but also contributes to the rigidity of the cabinet.

Drain Valve Access

For access to drain valve, remove lower service panel. The drain valve is a ball type and is powered closed by the drain valve motor. It is mounted under the washer tub on the left side. It is spring loaded open. If power is interrupted to the washer, the motor releases the sealing ball, allowing the drive spring to open the valve. With the valve open, all water in the washer will drain out.

Drain Valve Cleaning

- Step 1:** Loosen the clamp on the tub hose at the drain valve end and remove the hose from the drain valve.
- Step 2:** Loosen the drain hose clamp on the back of the drain valve. Remove two drain valve mounting racket screws from the frame of the washer.
- Step 3:** Disconnect red/white & white/red wire connection at clear connector.
- Step 4:** Remove the drain valve and bracket assembly. Unplug the wiring after the drain valve is removed from the washer.

Detergent Dispenser

Remove top panel to access dispenser. (see Removing Top Panel) Detergent is flushed from the front of the compartment and fabric softener is flushed from the back. There will be a small amount of water left in the fabric softener compartment after each use.

Vacuum Breaker (also called an air gap)

In the left rear of the cabinet is the vacuum breaker. It guides the water to the tub and dispenser and prevents a back flow of water.

Water Valves

Remove top panel to access water valves. (see Removing Top Panel) The two dual outlet water valves are mounted to the rear channel with two screws each. Always check inlet screens to be sure that they are clean. Disassembly requires the removal of two solenoid screws and three valve body screws. Below the solenoid coil is a solenoid guide, armature, armature spring and diaphragm. All valve parts are available individually or as a complete unit.

Door Lock Assembly Operation

After loading the clothing, the door should be closed and latched. The locking cam on the door contacts the latching switch actuator which closes the latching switch. The specified number of coins should now be added to start the washer. The solenoid pulls up on the locking pawl by use of a linkage rod. The locking pawl has two jobs. The first is to lock the door. This is accomplished by blocking the locking cam on the door so that it can't rotate to unlock. The second job is to close the two piggyback lock sensing switches. These switches control power to all of the controls. If the door unlocks for any reason, these two switches will stop the machine. When the door handle is 1/4 to 1/2 of an inch from its fully closed position, the latching switch should close. The two piggyback lock sensing switches should be open when the door is unlocked and should be closed when the door is locked.

Accessing the Door Lock Assembly

After removing the front panel the door lock assembly can now be accessed

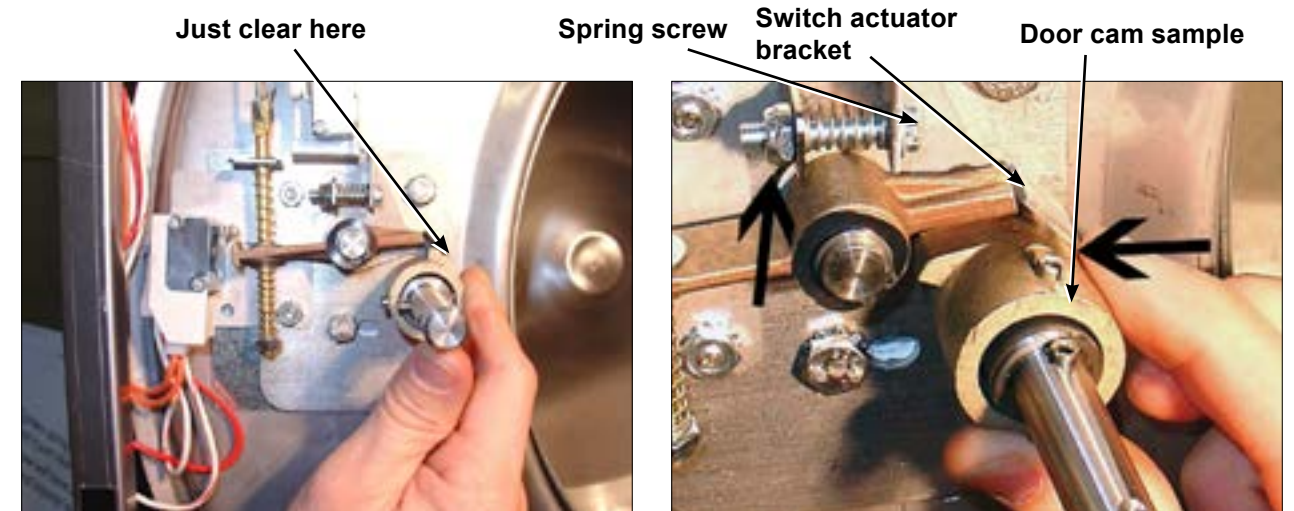

Step 1: Set door cam over pin. Here you can see the door cam away from the door lock assembly.

Step 2: Tighten spring screw on switch actuator bracket arm until it just clears cam OD. at base of door lock assembly.

Adjustment to this bracket usually is not necessary as next step is used more in field.

Flat blade screw on door switch latching



Step 3: With switch actuator bracket adjusted you will now need to adjust single switch by loosening 2 flat blade screws and allowing swivel of switch. Move switch towards above bracket until it actuates. Now tighten flat blade screws. Use a .040 thickness gauge to insert between bracket and switch and the switch should close and open again upon removal of thickness gauge.

Door cam check position



Step 4: Check for switch actuation at partial turn of cam as in operation above. Door handle goes from horizontal to six o'clock vertical.

Adjustment screw for (piggyback switches)

Top of flat end of locking pawl.

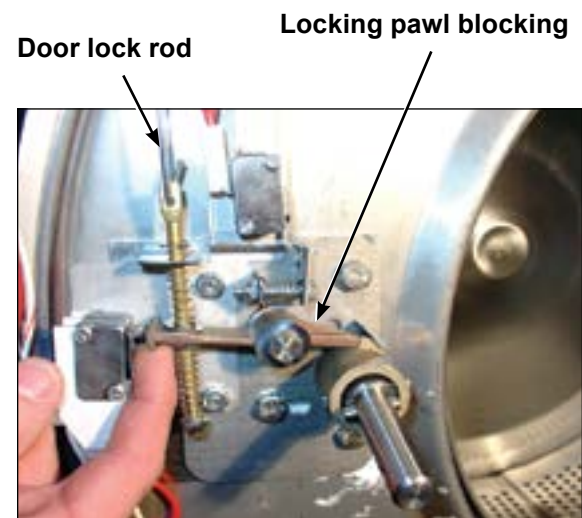

Step 5: Check that lock pawl arm swings to cam lobe to lock position.



Step 6: The lock stacked switches (piggyback) must be adjusted as door lock solenoid pulls up on door rod and locking pawl is now blocking door cam from turning and is in full up position. The stacked switches (piggyback) have a single actuator arm and it must actuate when single actuator roller wheel rolls to flat side of locking pawl. You will also notice a .040 gap between actuator arm and switch bodies.

Note: Both stacked switches must operate together!

Adjusting the Loading Door

The door can be adjusted by changing the number of shims behind the door hinge and the door lock assembly. The vertical fit of the door to the tub can be altered by loosening the door hinge bolts and raising or lowering the door before retightening. It is important for the door to be centered on the tub front. By chalking the front of the tub and closing the door to transfer that line to the gasket, the centering can be evaluated. It is also important for door pressure to be similar around the door perimeter. Door pressure can be evaluated by inserting a dollar bill in several positions and tugging on it. See Parts Section for kit to increase door sealing pressure.

Loading Door Removal



Step 1: Support door to prevent dropping.



Step 2: Remove 3 bolts holding hinge retainer clamp and set door off.

Loading Door Hinge Removal



Step 1: First remove loading door, front panel, and trim ring.



Step 2: Remove 3 screws holding door hinge. Shims may be present between hinge and tub front. The number may be increased or decreased to adjust right side door pressure.

NOTE: Door hinge mounting bolts penetrate tub front and require silicone sealer applied to holes when reinstalling.

Loading Door Disassembly

Step 1: Remove the loading door as outlined above. Lay the door on a flat surface with the glass down

Step 2: While holding down on the door glass, lift up on the door ring and roll back the lip of the gasket with your fingers.

Step 3: Work all the way around the gasket and the glass is out.

Loading Door Reassembly

Step 1: Lay the door ring face down on a flat surface. Start the glass into one side of the door gasket.

Step 2: Use one hand underneath to push the gasket out and the other hand on the top pulling the gasket in place

Step 3: The front lip of the door gasket should be checked for proper seating.

Control Panel Name Plate Decal

The name plate on washer front is adhesive backed.

Control Panel Name Plate Removal

The name plate may be removed by simply peeling it off.

Re-Installation of Name Plate

Step 1: Remove any remaining glue from the control panel.

Step 2: Before removing the paper backing from the name plate, check fit to the control panel. The program push buttons are the locating guides.

Step 3: Remove the paper backing from the right side of the name plate, position it on the panel and press right end into place. Peel the backing from the left end and press into place.

Outer Cabinet Removal

Removal of Cabinet T-350 & T-450

Step 1: The power supply, water hoses, and drain connection must all be disconnected before proceeding with the disassembly.

Step 2: Now remove the lower service panel and the top panel assembly.

Step 3: Remove the left and right lower front panel screws that retain the panel to the chassis.

Step 3: Remove the bottom row of back panel screws.

Step 4: Remove the loading door.

Step 5: Remove the screws along the bottom of each side panel. When reinstalling these screws do not overtighten.

Step 6: Remove clamp and soap dispenser hose where it attaches to the tub inlet. Disconnect the door lock wires from all switches and the door lock solenoid.

Step 7: Disconnect pull rod between solenoid and door lock assembly. Disconnect the wires to the dump valve at the bottom of the machine.

Step 8: Disconnect the wires to the drive motor from the VFD T1, T2, T3.

Step 9: Remove the clamp and the hose from the vacuum breaker where it connects to the inlet on the back of the tub.

Step 10: Remove the pressure switch hose from the bottom of the switch.

Step 11: It should now be possible for two people to lift the cabinet up and off of the front of the machine and set it aside.

Door Locking Gear Motor Assembly

The door locking gear motor is rotated shut with control voltage to lock the door and releases when voltage is removed. It is located in the left front corner of the washer. (Original locking solenoid models can be converted to the new assembly)

Thermoactuators

The thermoactuators are a safety device that keeps the door from immediately unlocking if power is lost while the machine is operating. They are mounted under the door locking solenoid.

Lock Thermoactuator

Control voltage is applied to the lock thermoactuator at the beginning of the cycle making it extend and block the door locking gear motor. This keeps the door locked for approximately two minutes after a power failure occurs. The lock thermoactuator does not delay the door opening at the end of a normal cycle.

Unlock Thermoactuator

To insure that the lock thermoactuator has retracted by the end of the cycle, one minute prior to the end of the cycle, the unlock thermoactuator is powered with control voltage making it extend and unblock the door locking gear motor.

Drive Belt Removal

Turn the drive pulley while applying pressure to the drive belt until it rolls off of the basket pulley first and then remove from the motor pulley. Be cautious not to drop the motor which could unhook the tension assembly.

Reverse this procedure for installation.

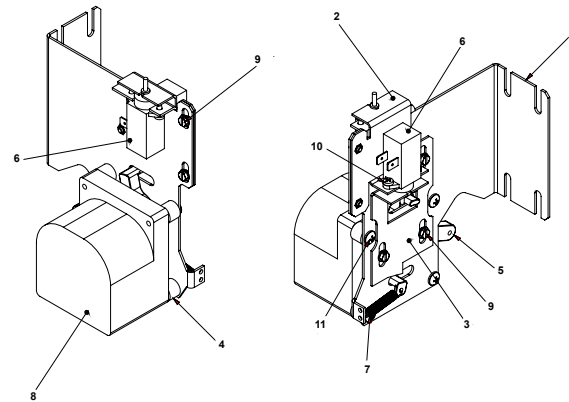

Door Lock Gear Motor

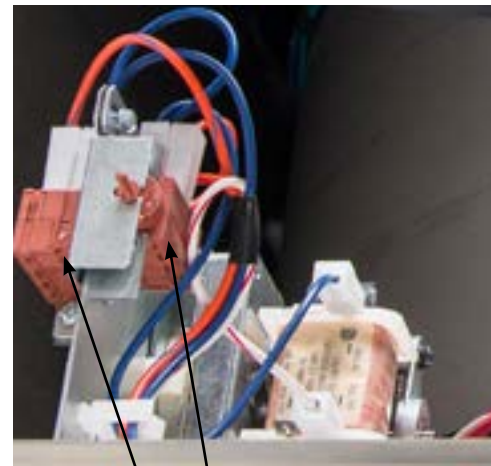

Thermoactuators



Drive Belt

Tub Back, Bearing and Cylinder Assembly

Basket assembly T-350 & T-450

Removal

Step 1: Remove the top and back panel as described.

Step 2: Move the rear channel, that the water valves mount to, forward by removing the five mounting screws.

Step 3: Remove the drive belt.

Step 4: Remove the overflow hose, tub fill hose and pressure switch hose from the back of the tub.

Step 5: Mark the tub back and bearing assembly for ease in assembly later. (see picture)

Step 6: Remove the 12 bolts and nuts from the perimeter of the tub back clamp ring. (Two of the twelve bolts are longer and go through the thicker part of the brace where it connects to the frame.)

Step 7: Remove the 2 bolts that fasten the clamp ring to the frame.

Step 8: The entire tub back and cylinder assembly may be lifted out of the tub (it may be necessary to break the adhesion of the silicone that seals the tub back to the tub). Blocks should be placed under the edges of the cylinder before setting it down to prevent damage to the cylinder flange.

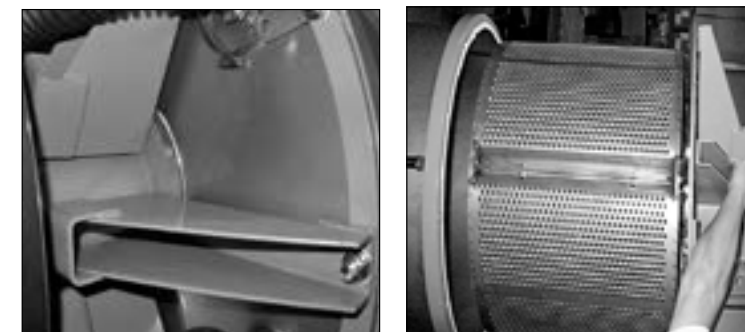

Reassembly

Reverse the procedures to the left paying attention to the following areas

Step 1: Lay the washer on its front. Note: Put a thick pad across the front of the washer, above the door, to protect the handle and coin acceptor.

Step 2: Make sure the bearing housing weep holes are located at 12 o'clock and 6 o'clock.

Step 3: Clean the silicone rubber from the back of the outer tub and the perimeter of the tub back where the two meet. There is no gasket in this area.

Step 4: Apply a new bead of silicone rubber around the back of the outer tub. (see picture)

Step 5: Lower the tub back, bearing and cylinder assembly into the washer outer tub.

Step 6: Torque all bolts according to the following charts.

Basket Pulley, Bearing Housing, Water Seals and Tub Back

The cast iron basket pulley is retained by a bolt, locking washer and a flat washer.



Removal

Step 1: Insert a large screw driver or punch through a spoke in the pulley into the bearing housing support. This keeps the pulley from turning.

Step 2: Remove the retaining bolt, lockwasher and flat washer and reinstall just the bolt

Step 3: Use a puller to remove the pulley from the shaft. Watch for tolerance ring.

Reassembly

Step 1: Make sure that the tolerance ring is in place inside the pulley.

Step 2: The shoulder inside the pulley that holds the tolerance ring should face the back of the washer when installed correctly.

Step 3: Use a stack of flat washers and a longer bolt to press the pulley onto the basket shaft.

Step 4: Reinstall the retaining bolt, lock washer and flat washer. The shaft end bolt with washer should be installed with a torque value listed in charts in this manual.

Removal of Bearing Housing From Basket Shaft, Bearings and Water Seals



Step 1: To remove the tub back assembly, the 6 bolts attaching it to the bearing housing must be removed.

Step 2: Remove water seals from the seal mounting plate on the cylinder shaft. These are removed with your fingers.

Step 3: The retaining ring next to the front bearing must also be removed.

Step 4: The bearings are pressed into the housing and must be pressed back out.

Reinstallation onto Basket Shaft

Step 1: Carefully set the assembly over the shaft engaging the bearings and bearing spacer.

Step 2: The tolerance ring that fits inside the pulley should be placed in position (see Basket Pulley Reassembly for correct positioning).

Step 3: The pulley should then be started onto the shaft. A stack of flat washers and a longer pulley bolt will be required to pull the basket shaft through the bearings and pulley.

Step 4: Install the shaft end bolt with washers and torque to specifications in Bolt Torque Chart.

Step 5: See Tub Back, Bearing and Cylinder Assembly for installation of complete assembly back into washer.

Reassembly

Step 1: When installing new bearings into a bearing housing, first press the front (large) bearing into the housing until it bottoms. With the bearing spacer in place, press the rear bearing in until the spacer is snug between the two bearings. Be sure and reinstall the retaining ring in front of the front bearing (see picture).



Step 2: The tub back assembly should be reattached to the bearing housing with the 6 mounting bolts and torqued according to the torque chart. **Note: The bead of silicone that seals each bolt to the tub back. This must be cleaned and replaced upon reassembly (see picture).**



If the 6 support assemblies have been removed from the bearing housing, the 6 rear bearing housing bolts should be torqued according to the chart also.

Step 3: The primary and secondary seals that mount on the sealing ring may be slid over the shaft and seated on the metal sealing ring. In the unlikely event that the metal ring that mounts these sealing rings were to be damaged or moved, a new one would need to be pressed on. The ring must be pushed against the stop on the shaft. Before installing the new sealing ring, a bead of silicone should be put on the basket shaft (see picture). After installing the seals, lubricate the faces of the seals with silicone grease (see picture).



Drive Motor Removal

Step 1: Remove the drive belt as explained in previous instructions.

Step 2: Remove the tension spring and bracket.

Step 3: Disconnect the motor wires in the control area at the top of the machine. The motor wire retaining clamp should be removed and reused. There is a diagram showing where each motor wire plugs in so there is no need to mark them.

Step 4: Loosen the set screws on the motor support shaft.

Step 5: Remove the retaining bolt from the front of the support shaft.

Step 6: Remove the motor support shaft.

Step 7: Lift motor out of machine. Note: On larger washers it is advisable to put a board under the motor and slide it out rather than lifting it.

T-350 & T-450 Bolt Torque Chart

Bolt Size	Where Used	Torque
1/2"x 1 1/4" bolt	Tub End of Bearing Hsing. 9545-017-009	70-110 ft/lbs
5/8"x 1 1/2" bolt	Tub End of Bearing Hsing. 9545-060-001	120-150 ft/lbs
1/2"x 1 1/4" bolt	Mtg. of Tub to Cradle Asy. 9545-017-009	70-110 ft/lbs
5/8"x 2 1/2" bolt	Mtg. of Tub to Cradle Asy. 9545-060-001	120-150 ft/lbs
3/8"x 1 1/2" bolt	Tub Back Ring to Tub Back 9545-029-003	45-80 ft/lbs

Control Mounting Trough

Remove top panel to access control trough. (see Removing Top Panel) It sets on the right side of the machine and holds the control PCB's, transformers, and pressure switch.

Main Data Communication Cable

Goes between front PCB board and Variable Frequency Drive unit mounted center rear of machine. It has telephone type connectors at each end and is inserted at Controller PCB and the Variable Frequency Drive.

Circuit Breaker/Fuse

The fuse (optional circuit breaker) mounts to the rear channel. It carries all of the controls in the machine but does not include the motor. To reset the circuit breaker just push in the button. If you have a fuse then remove fuseholder and fuse and replace with a 1 1/2 amp fast blow type fuse.



Fuse Location

Main Control Printed Circuit Board

Please be sure to be grounded to machine before removal of this board from machine. PC board mounted vertically behind front control panel. Remove hold down nuts in 4 corners and 1 at bottom center.

PCB Transformer Step-down

Small transformer mounted at front of control trough that is powered with 120 VAC primary and two secondary outputs of 2.3 VAC and 24-27 VAC.

Controls Transformer

This transformer is mounted at the back of the control trough and steps a range of 208 to 240 volts down to 120 volts for the controls. There are two terminals on the controls transformer for incoming power. One terminal tap is marked for 208 volts use this tap for measured voltage of 200 volts - 215 volts. and the other tap is marked 230 volts for 216 volts - 240 volts. Note: All washers have a controls transformer. Always check the incoming voltage and use the appropriate transformer terminal when installing ALL washers.

Main Relay Printed Circuit Board

Please be sure to be grounded to machine before removal of this board. PCB mounting horizontal in control trough towards front of machine. Remove 4 mounting nuts.

LED Printed Circuit Board Temperature & Start Display/Push-Button

The selector switch is mounted in the center of the control panel and is held in place with five nuts. It allows the selection of hot, warm or cold water temperatures. Note: Do not over tighten on reinstallation as the switch can be damaged, stay pushed in and will cause erratic displays.

Pressure Switch

The pressure switch sets the water level in the washer. As the water level rises, it compresses the air in the pressure switch hose. When the washer reaches the desired water level, the compressed air in the pressure switch hose opens the contacts in the switch, shutting off the water. When at the empty level, the pressure switch contacts are closed allowing the machine to either spin or fill with water.

Power Connection Terminal Block

This terminal block sets at the very back of the control trough. Incoming power to the washer should connect here. (see Electrical under Installation and Operation Section for exact connections)



Rear

Delta Variable Frequency Drive:

Main power is connected to terminals L1, L2, and L3 on the Delta drive. If the washer is connected to a three phase source, there should be voltage present on all three terminals. If the washer is connected to single phase power, there should be voltage present on terminals.

The voltage should measure 208 Volts to 240 Volts A.C. between phases and connected to if connected to three phase). There is a tolerance of + 10% on the mains voltage (187 Volts to 264 Volts).

Delta VFD Motor Leads:

The wires from the motor are connected to terminals T1, T2, and T3. Since this drive uses pulse width modulation, an accurate current or voltage reading is not possible. Although an accurate current reading is not possible, a balanced current reading should be present while the motor is running.

Delta VFD Dynamic Braking Resistors:

Two, 160 Ohm or 200 Ohm braking resistors (Please check your washer model parts requirements and quantities), are connected in parallel and attached to the drive at terminals B1 and B2. These resistors allow voltage, which is generated by the motor when decelerating, to be dissipated. They will become hot while the motor is slowing down, so care should be taken so as not to come in contact with them. This will prevent an electrical shock and/or a physical burn.

Delta VFD Cooling Fan:

There is a cooling fan attached to the bottom of the Delta drive. This fan will operate when the internal temperature of the drive reaches a predetermined level, the same way the radiator fan in a newer car operates. THE FAN CAN OPERATE ANYTIME POWER IS APPLIED TO THE DRIVE! Remove power to the drive if work is required around the fan.

Electronic Pressure Sensor

The Electronic Pressure Sensor comes standard on all models Starting Septembet, 1st 2015. Machines manufactured before this date can be upgraded with Kit 9732-213-001. The Pressure sensor is adjustable. The Factory settings chart will let you know the starting values for each machine and by following the Switch position chart you can adjust the water levels in 1/4 inch increments from that starting value.

Factory Settings:



Model	Vended		On-Premise	
	Switch #1 Efficient	Switch #2 Classic	Switch #1 Low Level	Switch #2 High Level
T-300	5.25	7.00	6.00	6.75
T-350	5.25	6.25	6.00	6.75
T-400	7.00	9.00	8.00	11.00
T-450	6.00	6.25	6.00	8.50
T-450 SWD	5.00	7.00	6.00	8.50
T-600	7.25	9.25	8.00	11.00
T-650	6.50	8.25	8.00	11.00
T-750	6.00	7.50	6.00	8.75
T-900	6.00	7.50	6.00	8.75
T-950	6.00	7.50	6.00	8.75
T-1200	6.00	7.50	6.00	8.75
T-1450	6.75	7.00	6.75	9.50

Switch Positions:

Depth (in):	Pos 1	Pos 2	Pos 3	Pos 4	Pos 5	Pos 6
5.00						
5.25	on					
5.50		on				
5.75	on	on				
6.00			on			
6.25	on		on			
6.50		on	on			
6.75	on	on	on			
7.00				on		
7.25	on			on		
7.50		on		on		
7.75	on	on		on		
8.00			on	on		
8.25	on		on	on		
8.50		on	on	on		
8.75	on	on	on	on		
9.00					on	
9.25	on				on	
9.50		on			on	
9.75	on	on			on	
10.00			on		on	
10.25	on		on		on	
10.50		on	on		on	
10.75	on	on	on		on	
11.00				on	on	
11.25	on			on	on	
11.50		on		on	on	
11.75	on	on		on	on	
12.00			on	on	on	
12.25	on		on	on	on	
12.50		on	on	on	on	
12.75	on	on	on	on	on	
13.00						on
13.25	on					on
13.50		on				on
13.75	on	on				on
14.00			on			on
14.25	on		on			on
14.50		on	on			on
14.75	on	on	on			on
15.00				on		on

Electrical Path Circuit Schematics

Start Circuit

Power travels into the machine on L1 & L2 and (L3 if 3 phase used). Power from the L1 & L2 supplies power to the 12vdc power supply. This power being sent to the Control PCB. 115vac, 24vac, and the ac Neutral is created by the control transformer. The 115vac and 24vac is being sent to the Terminal Blocks. Power from the L1 and L2 also supplies power to the 12VDC power supply. The 12VDC power is sent directly to the Control PCB on the blue wires.

- All 115vac power is designated in the machine by red wire connections and the 115vac neutral is designated by white wires with a red stripe. (wht/red) All 115 AC Voltage begins at the terminal block for 115VAC supplied through a control fuse located next to the terminal strip.
- All 24vac power is designated in the machine by orange wire connections and the 24vac neutral is designated by white wires with an orange stripe. (wht/org) All 24 AC Voltage begins at the terminal block for 24VAC supplied through a control fuse located next to the terminal strip.
- All 12vdc power is designated in the machine by blue wire connections and the 12vdc ground is designated by white wires with a blue stripe. (wht/blu)

Closing the door will engage the door hinge closed switch, sending the J11-5, 12vdc voltage to the blue/white wire and over to the S1 door latched switch. Turning the door handle to the vertical latched position closes the primary door latched switch, returning the 12vdc voltage to the main control PCB on the blue/orange wire at the J11-2 connection. This proves the door is closed and latched and ready for safe operation.

A 12VDC signal to J11-2 of the Control PCB and 120vac at the J4-14 of the relay PCB makes 120vac available to the K9 door lock relay. A continuous 5VDC signal is sent out on the J11-6 brown wire and returned on the brown/white wire to the J11-3 connector of the control PCB. This is passed through the (normally closed) emergency stop button switch.

The Washer is ready for operation.

The cycle is selected using the up and down buttons. The start button is now pressed. The control signals the relay board to close relay K9 sending 120vac to the door lock on the red/brown wire. The door lock motor engages and pulls up on the door locking rod which locks the door and closes the S3 and S4 door locking switches. This sends the 12vdc signal back to the control at J11-1 on the blue/grey wire. This 12VDC also pulls in the K4 relay which sends 24vac to the normally closed K2 relay that powers the Locking Thermoactuator to expand and block the locking mechanism. At the same time the K5 relay is engaged sending an enable signal to the variable frequency drive. 120VAC will go to the door lock assembly from the P17 connector of the relay PCB on the red/brown wire. The door lock motor engages and pulls up on the door locking rod, locking the door and closing the S2 and S3 door locking switches. The Locking Thermoactuator receives 24vac on the orange/green wire and will expand to block the locking mechanism.

Note: If the door locked signal is not received after one second from pressing the Start button, no motion occurs and the error message "DOOR SHUT, NOT LOCKED" will appear on the display. The washer will not restart until the power is removed and re-applied.

The door lock gear motor will test the door locking circuit 10 seconds before the end of the first stage. The control will release the 120VAC to the red/brown wire which will cause the Gear Motor to release which tests the Locking Thermoactuator safety circuit. This release will last for 10 seconds. As long as the Thermoactuator has properly extended to block the door locking mechanism, the machine will continue as normal.

Agitation Circuit

When the 12VDC signal closes the K5 in the Control PCB it closes the loop in the yellow wire from the VFD terminal MI6 back to the DCM on the white/yellow through the stop button. This enables the Drive to operate and allow motion. If the K5 is not closed or the Aux Stop Button is engaged there will be no motion. A proximity sensor is used to verify that the cylinder is turning when the VFD is commanded to operate. If the VFD frequency is greater than 0 Hz and the proximity sensor has no change in output for 10 seconds, the error code "NO PROX SENSOR OUTPUT" is displayed. The K7 Closes supplying 120vac on the red/brown to energize the Drain Valve. This supplies power to close the valve. The main control PCB sends data commands to the VFD through the data cable connected at P-2. These commands control all wash cylinder movement. The type of agitation is programmed in the control settings.

- o Agitation type: Normal, delicate, or 3 custom options
- o Agitation time
- o Spin speed
- o Spin time

Fill Circuit-Warm Stage

During the machine fill, a 12vdc signal is sent on the blue wire from the J8-1 connection of the main control PCB to the pressure switch common contacts. This 12vdc returns on the blue/yellow wire for low level and blue/red wire for high level.

Note: Unlike the other previous Dexter washers, with O-Series Controls the empty signal is an open circuit, full is a closed circuit.

The washer fills the tub through the back of the machine with either one or both the C1/C3 cold and H1/H3 hot water fill valves. From the P4 connection of main relay PCB, 120vac is sent out of the K4 relay on the red/pink wire to the C1/C3 cold water fill valve. 120vac is sent out of the K1 relay on the red/grey wire to the H1/H3 hot water fill valve depending on the programmed bath temperature. If the washer does not initially reach low water level within 7 minutes the cycle will continue and "SLOW FILL ERROR" will be displayed alternately with the Cycle Progress screen. (This is the case unless "None" is chosen for fill level). The alternating "SLOW FILL ERROR" will be displayed the rest of the cycle even when the "CYCLE DONE" screen is displayed. It will reset when the user opens the door.

If the "SLOW FILL ERROR" occurs after 7 minutes and the water level is still not met at 15 minutes, the washer will come to a controlled stop. The current stage will end, and the cycle will not continue. The "SLOW FILL ERROR" will be displayed on the screen until reset. Even on high fill, as long as the low water level is met one time during a stage, the "SLOW FILL ERROR" will not be displayed during the remainder of the stage. This includes if the low water level is met before 7 minutes, then drops again and requires additional filling.

Soap Dish flush / Injection Signals

The signal for the Detergent, Softener or Injection Signals are programmable to engage for 0 to 150 seconds. By setting up the injection or flush in the programming, a 120V signal will be sent from the main or secondary relay board to a specific flush valve or injection terminal on the back of the machine. The Hot Detergent flush is powered from the Red/Black of the main relay board. The Cold Softener flush is powered from the Red/Violet of the main relay board. All Injection Terminal Strip signals are powered from the Grey wires of the secondary relay board. All 120v neutral is carried through the white/red wires.

The Detergent Flush, Softener Flush or Injection Signal start time is selectable from 0 to 150 second delay. The start time of the delay count down is dependent on the settings of the Delay Fill option. This Delay Fill option is a global setting which affects all stages of all cycles. The default setting is Delay Fill enabled which means that the Compartment flush or injection signal delay time will not start counting down until AFTER the low level fill has been achieved. (If the setting is changed to "disabled", then the countdown will begin from the beginning of the stage.

T-350 -12 O1 Schematic

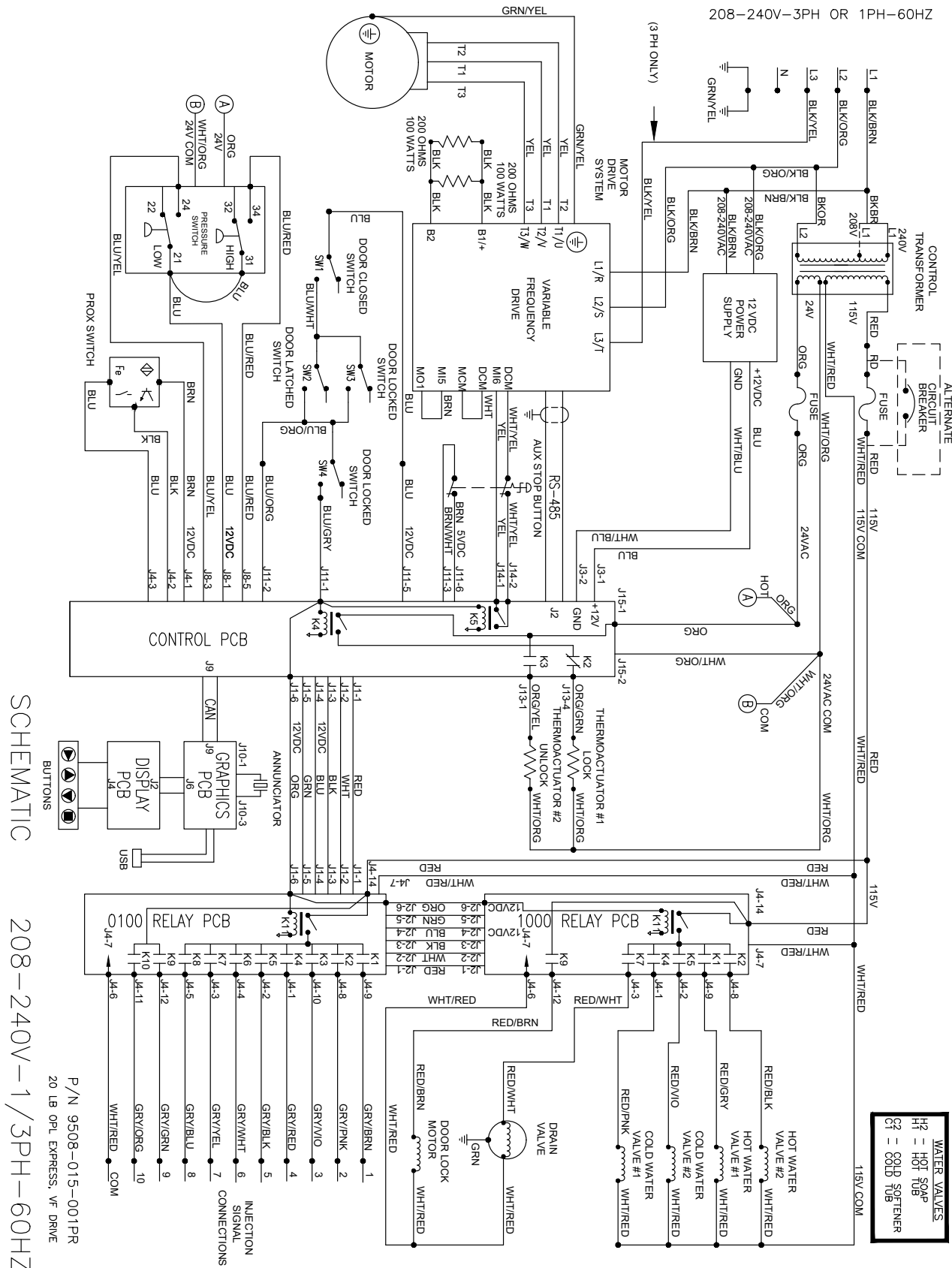

SCHEMATIC

208-240V-1/3PH-60HZ

T-350 -12 O1 Diagram

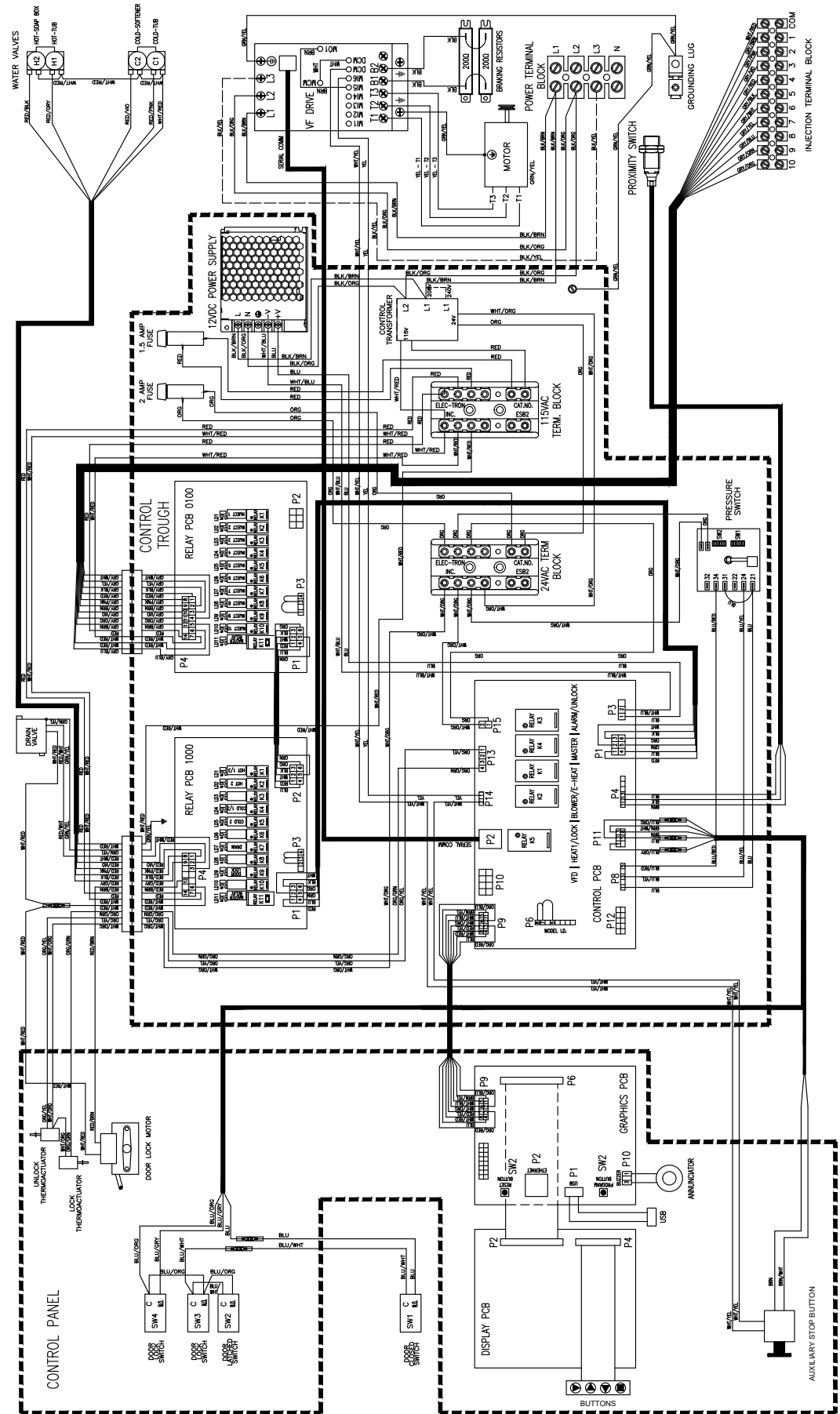

208 - 240V, 1/3PH, 60HZ

P/N 9507-015-001PR
20 LB OPL EXPRESS, VF DRIVE
W0350V--12_O_X

O-Series Accessories

T-350	WN0350XA-12EO1X	208-240 volts 60hz	Single Phase or Three Phase
T-450	WN0450XA-12EO1X	208-240-volts 60hz	Single Phase or Three Phase

Key	Description	T-350	T-450	QTY
*	Kit, Door Gasket Expander (large)	9732-139-002	9732-139-002	1
*	Kit, Door Gasket Expander (small)	9732-139-001	9732-139-001	1
*	Hose, Water Supply 3/8" I.D. x 48"	9990-027-011	9990-027-011	2
*	Washer, Inlet Hose (furnished)	8641-242-000	8641-242-000	2
*	Strainer, Inlet Hose (furnished)	9565-003-001	9565-003-001	2
*	Bevel Washer for 5/8" bolt used in installations using angle iron bases	8641-586-002	8641-586-002	4
*	Sealing compound RTV-45	8538-151-002	8538-151-002	AR
*	Flow Restrictors (in dispenser)	9475-002-002	9475-002-002	2
*	OPL Bearing & Seal Kit	9732-219-008	9732-219-005	1
	USB, W/ owners booklets	9150-045-002	9150-045-002	1



Section 8:

Parts Data:

T-350	WN0350XA-12EO1X	208-240 volts 60hz	Single Phase or Three Phase
T-450	WN0450XA-12EO1X	208-240-volts 60hz	Single Phase or Three Phase

Kits, Assemblies, & Common Parts

Description	T-350	T-450
Cylinder and Tub Back	9732-354-002	9732-354-004
Kit - Door Lock Assy. & Cam, replaces 9885-024-001	9732-347-001	9732-347-001
Kit - Door cam replacement	9732-346-002	9732-346-002
Kit - Locking Pawl replacement	9732-346-001	9732-346-001
Kit - 8650-012-003 Lock with spacer	9732-344-001	9732-344-001
Kit - 3" Drain valve seal replacement	9732-327-001	9732-327-001
Drain Valve 3"		9379-202-001
Drain Valve 2"	9379-199-001	
Water Valve (Dual)	9379-183-012	9379-183-012
Diaphragm	9118-049-003	9118-049-003
Cylinder Plug (1.5" Plastic)	9456-041-007	9456-041-007
Electronic Pressure Switch	9732-315-001	9732-315-001
Delta E Drive Display	9150-044-001	9150-044-001
Breaking Resistor 200 Ohms	9483-004-002	9483-004-002
Transformer	8711-017-001	8711-017-001
Main Control Board	9799-027-001	9799-027-001
Data Cable	9806-023-003	9806-023-003
Door Lock Gear Motor Assembly	9922-015-003	9922-015-003
Door Lock Latching Assembly	9885-031-001	9885-031-001
Door Handle Only	9244-091-001	9244-091-001
Front Panel Screw	9545-008-014	9545-008-014
Front Panel Finisher Washer	8641-585-001	8641-585-001
Front Panel Spring Nut	8640-442-001	8640-442-001
Soap Box Screw	9545-008-012	9545-008-012
Soap Box Spring Nut	8640-399-007	8640-399-007
5/16 Hex Screw	9545-008-026	9545-008-026
Belt	9040-079-004	9040-079-005
Key, Top- # 6324	6292-006-007	6292-006-007
Fuse Holder Assembly	9200-001-002	9200-001-002
Fuse, 2 Amp Slow, 1/4 x 1-1/4	8636-018-005	8636-018-005
Fuse, 1.5 Amp Fast, 1/4 x 1-1/4	8636-018-001	8636-018-001
Door Glass Gasket	9206-411-002	92406-419-001

Wiring Harness Part # by Model

Key	Description	T-350	T-450	QTY
*	Cable Assy. USB	9806-024-001	9806-024-001	1
*	Wiring Harness, Door Lock	9627-936-002	9627-936-002	1
*	Wire Assy. Blue 17"	8220-063-047	8220-063-047	1
*	Wire Assy. Blue / White 17"	8220-063-048	8220-063-048	1
*	Wiring Harness, Power Terminal Block	9627-932-002	9627-932-002	1
*	Wiring Harness, Injection	9627-935-002	9627-935-002	1
*	Wire Assy. Brown #21, 3"	8220-057-035	8220-057-035	1
*	Wire Assy. White 3"	8220-057-036	8220-057-036	1
*	Wire Assy. Black Jumper Braking Resistors	8220-117-002	8220-117-002	1
*	Data Cable	9806-023-003	9806-023-003	1
*	Wire Assy. White/Red Jumper Water Valves	8220-123-002	8220-123-002	1
*	Wiring Harness, 15-Pin Non-Injection	9627-934-002	9627-934-002	1

Cabinet and Front Panel Group Part # by Model

Key	Description	T-350	T-450	QTY
*	Panel, Side (Left or Right) - stainless		9732-359-007	2
*	Panel, Right Side-stainless	9989-640-001		1
*	Panel, Left Side - stainless	9989-640-002		1
*	Screw, (Side Panel to Base)	9545-018-018	9545-018-013	6
*	Nut, Hex 1/4-20 UNC	8640-414-006	8640-414-006	6
*	Pad-Foam, Side Panel	0904-904-001	0904-904-001	2
*	Bracket, Side Panel under front panel	9029-263-001	9029-263-001	1
*	Nut, Hex (to tub front)	8640-413-002	8640-413-002	2
*	Screw, #10B x 1/2	9545-008-026	9545-008-026	2
2	Panel, Control	9454-597-001	9454-955-001	1
*	Screw, Control Panel to Sides	9545-008-026	9545-008-026	4
3	Nameplate Decal, Control Panel (Black)	9412-241-001	9412-242-001	1
4	Button, Push	9035-063-001	9035-063-001	1
5	Panel Assy, Front	9989-612-003	9989-598-001	1
*	Trim Edge Protector	9578-092-005	9578-092-005	1
*	Label, Warning-Door Opening (Black)	8502-757-001	8502-757-001	1
*	Label, Warning-Door Risk of Injury (Black)	8502-759-001	8502-759-001	1
10	Door, Lower Service (includes handle & Rivits)	9960-286-001	9960-286-002	1
11	Handle (bumper guard)	9244-086-001	9244-086-002	1
*	Rivet	9491-009-003	9491-009-003	4
*	Washer, Finish	8641-585-001	8641-585-001	2
*	Nut, Spring	8640-442-001	8640-442-001	2
15	Lock, Top (w/Key)	8650-012-003	8650-012-003	1
*	Lock Spacer	9538-189-001	9538-189-001	1
*	Key, Top- # 6324	6292-006-007	6292-006-007	1
16	Bumper-Loading door	9051-055-001	9051-055-001	1



Rear View Access Part # by Model

Key	Description	T-350	T-450	QTY
1	Drive Motor	9376-307-001	9376-319-001	1
2	Pulley, Motor	9453-180-001	9453-181-001	1
*	Set Screw,Sq.Hd(motor pulley)	9545-028-015	9545-028-015	2
3	Rod, Motor Mtg	9497-222-002	9497-222-002	1
*	Screw (end of motor rod)	9545-029-005	9545-029-005	1
*	Lockwasher (end of motor rod)	8641-582-014	8641-582-014	1
4	Motor Bushing (Rubber)	9053-082-001	9053-082-001	2
5	Clamp-Worm, 316SS, 1.5"	8654-117-019	8654-117-019	2
6	Strap Bracket, Motor Tension	9029-206-001	9029-206-002	1
*	Nut, Strap to Motor 10/32 UNF	8640-413-002	8640-413-002	1
*	Washer #10	8641-581-006	8641-581-006	1
7	Spring, Belt Tension	9534-319-002	9534-319-002	1
8	Pulley, Driven	9453-168-005	9453-168-006	1
*	Tolerance Ring (Driven Pulley)	9487-234-001	9487-234-003	1
9	Screw 1/2-13x1 1/4"	9545-017-009		1
9	Screw 5/8-11x1 1/2" Driven pulley		9545-060-001	1
10	Lockwasher 1/2"	8641-582-016		1
10	Lockwasher 5/8"		8641-582-018	1
11	Washer, Flat 1/2"	8641-581-026		1
11	Washer, Flat 5/8x2 1/4"		8641-581-032	1
12	Drive Belt	9040-079-004	9040-079-005	1
17	Hose, Overflow Suds, 11"	9242-463-002	9242-463-003	1
*	Clamp, Hose Vent	8654-117-008	8654-117-008	1
13	Hose, Overflow to drain	9242-449-002	9242-449-002	1
*	Clamp, Hose overflow to drain	8654-117-018	8654-117-018	2
14	Hose, Pressure Switch	9242-175-000	9242-175-007	1
*	Clamp, Pressure Switch Hose	8654-117-015	8654-117-015	1
*	Vacuum Breaker Mtg Bracket	9029-266-001	9029-077-001	1
*	Vacuum Breaker ALL	9610-001-001	9610-001-001	1
*	Clamp, Hose to Vacuum Breaker	8654-117-014	8654-117-014	1
*	Hose, Vacuum Breaker to tub	9242-458-001		1
*	Hose, Vacuum Breaker to Injector		9242-461-001	1
*	Clamps	8654-117-014	8654-117-014	1
15	Injector Assembly, Soap		9883-010-001	1
*	Hose, Injector to Tub Back		9242-462-001	1
*	Clamp		8654-117-014	1
16	Cap-Injector Assy		0935-127-001	1
*	Clamp		9242-117-008	1
*	Panel Assy., Back	9454-632-001	9989-562-001	1
*	Screw Panel Mtg.#10Bx1/2"	9545-008-026	9545-008-026	10
*	Nut, Spring	8640-399-004	8640-399-004	6
*	Screw, To Base-1/4x3/4		9545-030-002	1

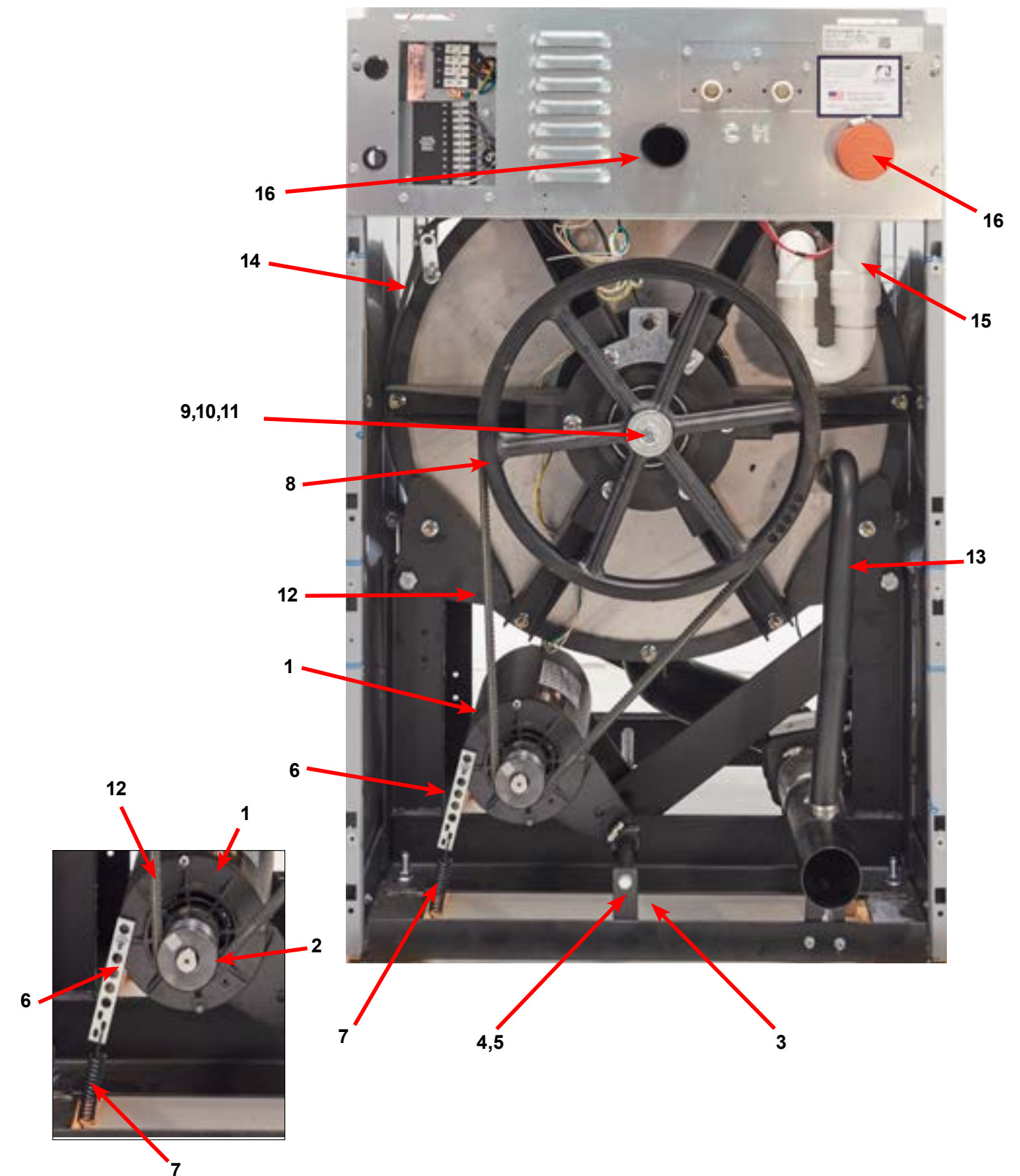

Key	Description	T-350	T-450	QTY
1	Channel, Rear	9947-025-001	9947-026-001	1
2	Screw #10Bx1/2	9545-008-026	9545-008-026	4
*	Nut, Spring	8640-399-007	8640-399-007	4
3	Plug, 7/8"	9456-041-006		1
4	Bushing, 7/8"	9053-067-002		1
5	Bracket-Terminal Block Assy	9029-265-001	9029-265-001	1
6	Screw, 10Bx1/2	9545-008-026	9545-008-026	4
7	Strip-Terminal marker, Power	9558-025-001	9558-025-001	1
8	Terminal Block-Power	9897-033-002	9897-033-002	1
*	Screw-6ABx3/4	9545-031-010	9545-031-010	2
9	Harness-Power Terminal Block	9627-932-002	9627-932-002	1
10	Terrminal Lug, Solderless	8652-134-001	8652-134-001	1
*	Lockwasher #10	8641-582-006	8641-582-006	1
11	Screw-10-32ttX1x1/2 GRN	9545-008-027	9545-008-027	2
12	Strip-Terminal Marking, Injector, 11 position	9558-036-001	9558-036-001	1
13	Terminal Block-Injector	9897-032-003	9897-032-003	1
*	Screw-4Bx5/8ss	9545-053-002	9545-053-002	2
14	Harness-Injection	9627-935-002	9627-935-002	1
15	Label-Warning	8502-639-001	8502-639-001	1
16	Bushing-Insulated, 3/4"	9053-067-001	9053-067-001	1
17	Bushing-Insulated, 1"	9053-067-004	9053-067-004	1
*	Cover, Terminal Block	9074-267-001	9074-267-001	1
*	Screw #10Bx1/2	9545-008-026	9545-008-026	1
18	Plate Drive Mounting	9982-382-001	9982-383-001	1
19	Nut-#10-32UNF, 2B	8640-413-002	8640-413-002	4
20	VFD Delta "E" drive 208-240 volt	9375-032-015	9375-030-019	1
*	Cable, Data	9806-023-003	9806-023-003	1
*	VFD Cooling Fan	9189-013-001	9189-013-001	1
*	VFD, MS300, O2	9375-034-015	9375-035-016	1
*	VFD Cooling Fan	9189-015-001	9189-016-001	1
21	Nut-#10-32UNF 2B	8640-413-002	8640-413-002	4
22	Mounting Plate Water Valves	9452-813-001	9452-813-001	1
23	Nut-Elastic stop, #10-32	8640-413-002	8640-413-002	2
24	Valve-Water, Duel Coil	9379-183-012	9379-183-012	2
25	Screw #10Bx1/2	9545-008-026	9545-008-026	4
26	Shield over Water Valves Plastic	9550-194-001	9550-194-001	1
27	Push Clip	9083-121-001	9083-121-001	3
28	Vacuum Breaker	9610-001-001	9610-001-001	1
*	Bracket-Vacuum Breaker	9029-266-001	9029-077-001	1
*	Vacuum Breaker Cap (Red)	0935-135-002	0935-135-002	
29	Screw, 10Bx1/2	9545-008-026	9545-008-026	4
30	Cap-Injector Assy		0935-127-001	1
*	Clamp		9242-117-008	1
31	Hose, Vacuum Breaker to Injector		9242-461-001	1
32	Clamps		8654-117-014	1
33	Hose-Suds Overflow	9242-463-002	9242-463-003	1
34	Braking resistors (200 ohm)	9483-004-002	9483-004-002	2
35	Screw-#10Bx1/2	9545-008-026	9545-008-026	4

Rear View Access Part # by Model Continued

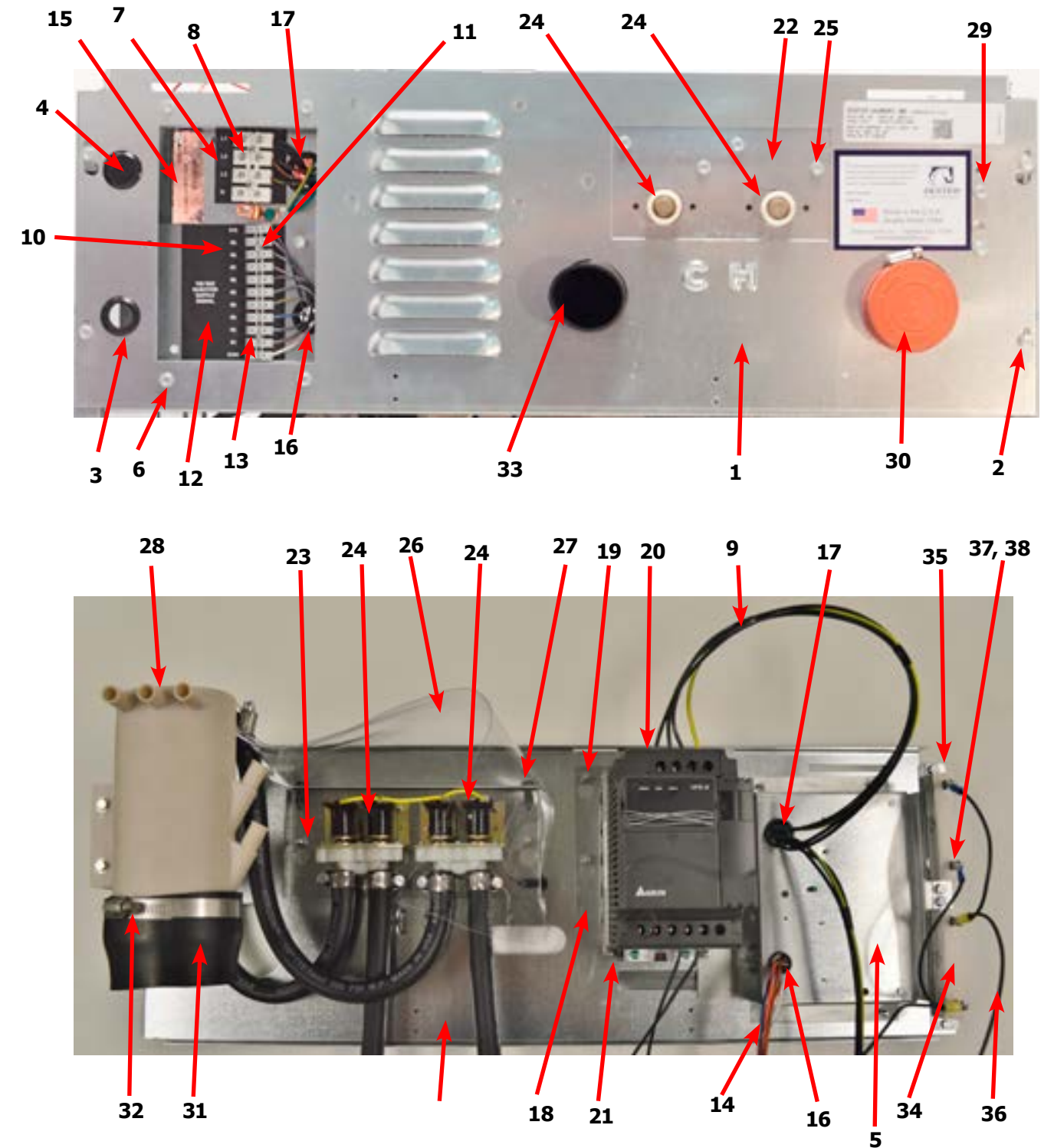

Cylinder, Seals & Bearings Part # by Model

Key	Description	T-350	T-450	QTY
*	Bearings and Seal Kit	9732-219-008	9732-219-005	1
*	Housing, Bearing- Assembly (items #2-#6)	9803-179-003	9803-186-001	1
2	Housing, Bearing	9241-169-002	9241-180-002	1
3	Bearing, Front (LARGE)	9036-159-009	9036-159-005	1
4	Bearing, Rear (SMALL)	9036-159-008	9036-159-004	1
5	Spacer, Bearing	9538-158-001	9538-167-001	1
6	Ring, Bearing Retainer	9487-238-001	9487-238-003	1
7	Tub Back Mating Ring	9487-261-002	9487-261-003	1
8	Seal, Large	9532-140-009	9532-140-009	1
9	Seal, Small	9532-140-003	9532-140-006	1
10	Ring, Seal Mounting	9950-042-001	9950-048-001	1
11	Back Assy, Tub 2 piece	9962-016-001	9962-013-002	1
12	Bolt, Tub End of Bearing Housing (1/2" x 1 1/4")	9545-017-009		6
12	Nut 1/2'	8640-417-005		6
12	Flat washer 1/2"	8641-581-034		6
12	Bolt 7/16-14x1 1/2" Tub end of bearing housing		9545-059-003	6
12	Nut 5/8"		8640-425-001	6
13	Support Arm Assy, Bearing Housing	9991-057-002	9991-056-002	6
*	Tub Alignment Spacer	9552-038-003	9552-038-003	
14	Bolt Pulley End of Bearing Housing (3/8" x 1 1/2")	9545-029-003		6
14	Nut, Flange Locking 3/8"	8640-415-004		6
14	Bolt Pulley end of bearing housing (7/16-14x2")		9545-059-002	6
14	Nut, Flange Locking 7/16"		8640-416-005	6
15	Pulley, Driven	9453-168-005	9453-168-006	1
*	Ring, Tolerance	9487-234-001	9487-234-003	1
16	Washer 1/2"	8641-581-026		1
16	Washer 5/8"		8641-581-032	1
18	Bolt 1/2-13 x 1 1/4"	9545-017-009		1
18	Bolt 5/8-11x1 1/2"		9545-060-001	1
20	Lockwasher 1/2" Ext. tooth	8641-582-016		1
18	Lockwasher 5/8 Ext. tooth		8641-582-018	1
*	Cylinder Assy Before Serial # W1.20190.XXX	9732-354-002	9732-354-004	1
*	Cylinder Assy After Serial # W1.20190.XXX	9848-164-001	9848-166-001	1
*	Tub and Cylinder Assy.	9869-029-001	9869-031-001	1
*	Tub Assembly	9930-160-001	9930-162-001	1

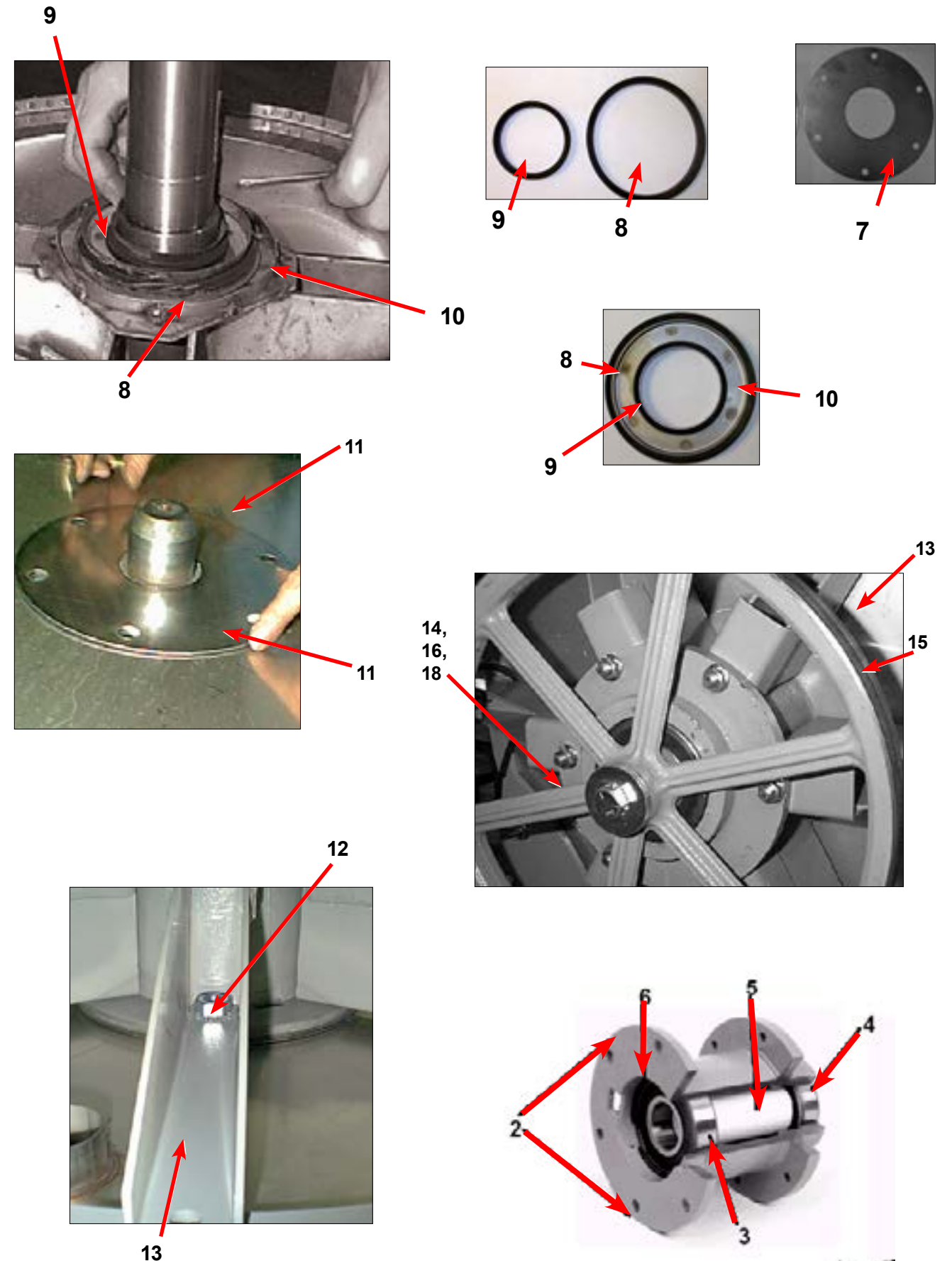

Door Lock Assembly (All Models)

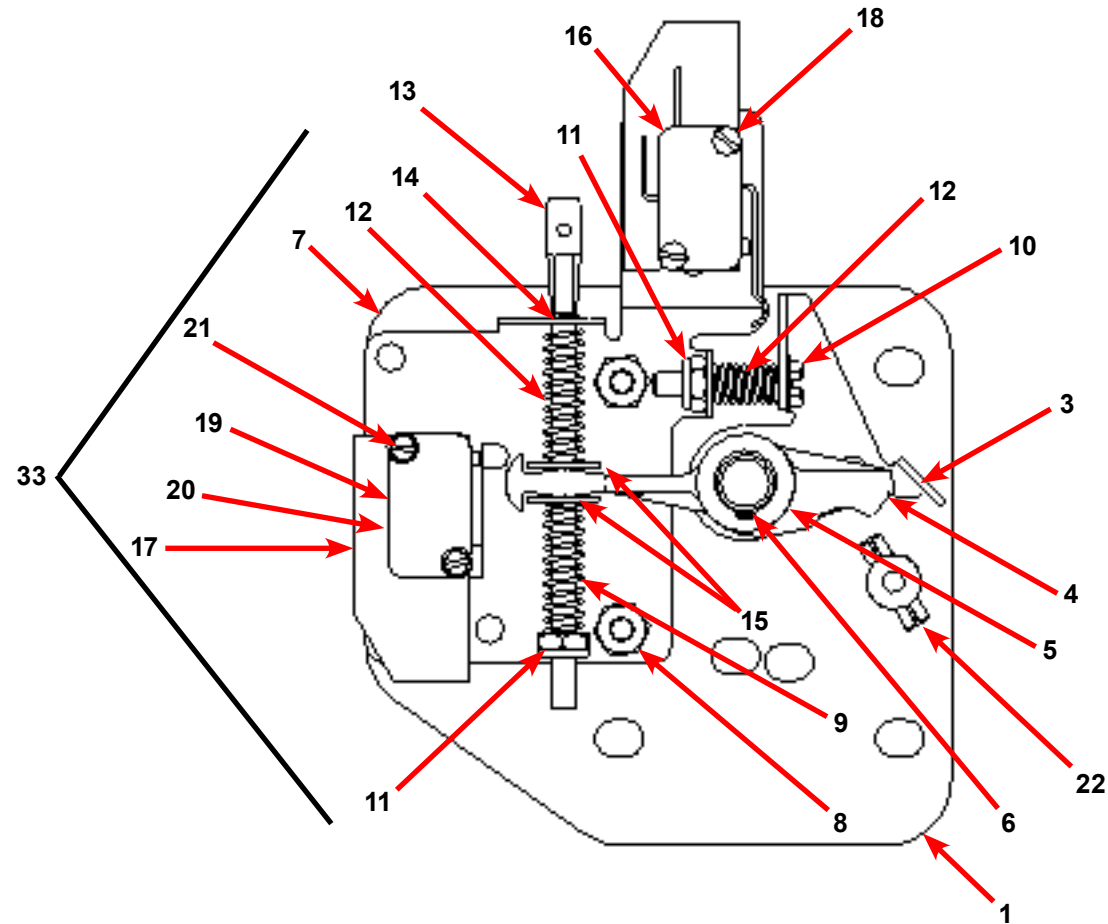

Key	Description	All Models	QTY
*	Lock Assy, Complete (#1-22) (includes #1 thru #22)	9885-031-001	1
1	Plate Assy, Door Lock	9982-346-001	1
2	Washer, Flat (SS or Brass)	8641-581-030	1
3	Actuator, Latching Switch	9008-005-001	1
4	Pawl, Locking	9732-346-002	1
5	Washer, Spring	8641-569-003	1
6	Ring, Retaining	9487-200-004	1
7	Bracket Switch	9029-163-001	1
8	Nut, Hex 10-32 UNF	8640-413-002	2
9	Spring, Actuating	9534-364-002	1
10	Screw, Hx. 10-32 x 1"	9545-012-020	1
11	Nut, Elastic Stop 10-32	8640-413-004	2
12	Spring, Return	9534-364-001	2
13	Pin, Guide	9451-193-001	1

Key	Description	All Models	QTY
14	Ring, Retaining	9487-200-005	1
15	Washer	8641-581-031	1
16	Switch, Latching Sensing	9539-461-008	1
17	Shield, Switch	9550-169-003	3
18	Screw 4-40 x 5/8"	9545-020-001	2
18	Nut, Twin 4-40	8640-401-001	1
19	Switch, Locking Sensing	9539-461-007	2
20	Actuator, Switch Locking	9008-006-003	1
21	Screw 4-40 x 1 1/8"	9545-020-003	2
21	Nut, Twin 4-40	8640-401-001	1
*	Spacer Sensor	9538-182-001	*
22	Pin, Dowel (for door cam)	9451-181-004	1
*	Shim, Door Lock, Thin	9552-037-001	AR
*	Screw, Lock mtg 1/4"-20 x 3/4"	9545-018-014	3
*	Lockwasher 1/4" Ext tooth	8641-582-007	3
*	Door Stud Pin, 3/16" x 3/4"	9451-181-004	1

Gear Motor Door Lock Assembly

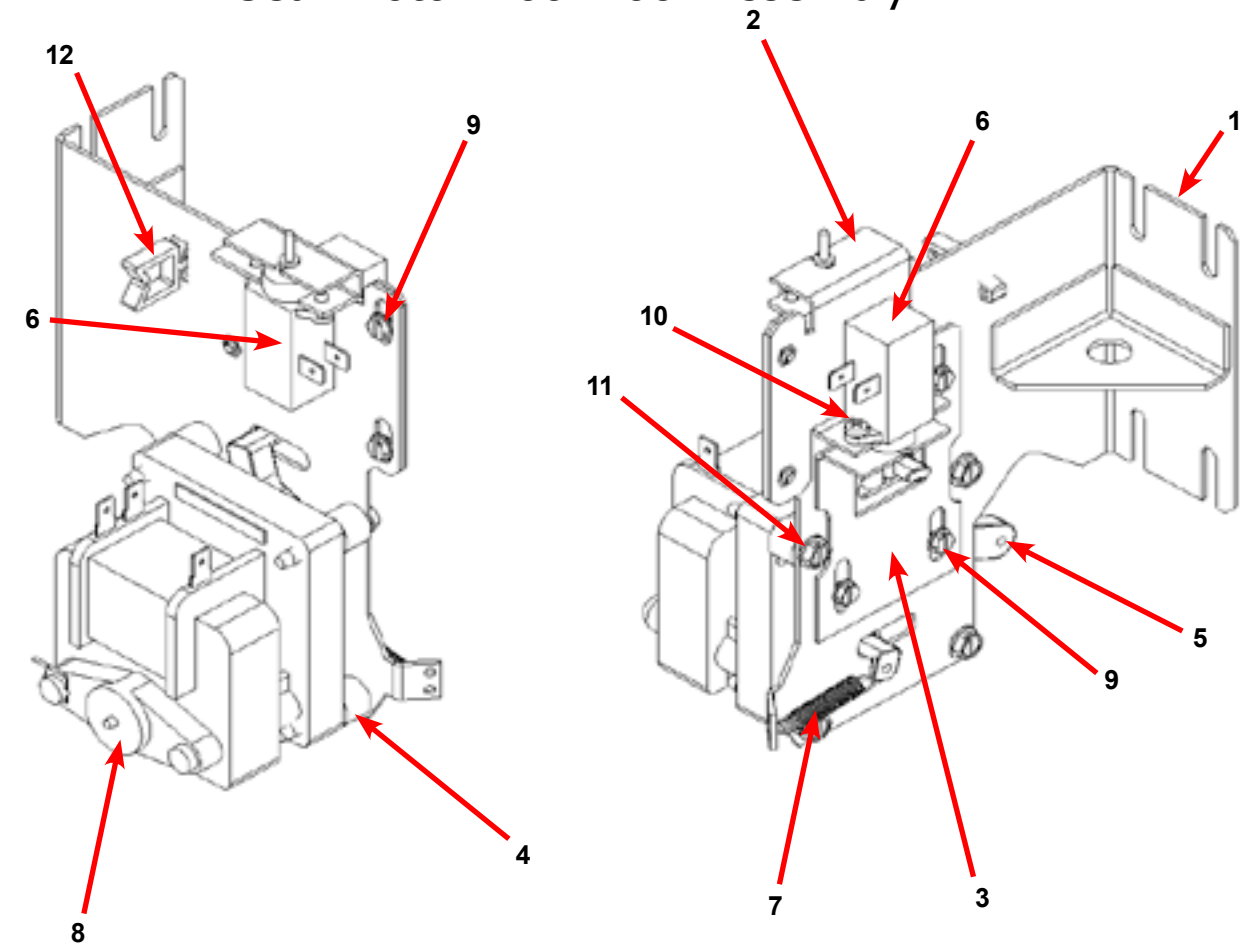

Key	Description	T-350	T-450	QTY
*	Actuator Assembly (Includes 1-10, Rod NOT included)	9892-015-003	9892-015-003	1
1	Bracket Assy, Slide Lock Actuator	9985-190-001	9985-190-001	1
2	Bracket Assy, Slide - Unlock	9985-189-001	9985-189-001	1
3	Bracket Slide Lock	9029-204-001	9029-204-001	1
4	Spacer, Plastic	9538-157-021	9538-157-021	4
5	Arm - Door Lock	9001-063-001	9001-063-001	1
6	Thermoactuator - 24VAC	9586-001-003	9586-001-003	2
7	Spring - Extension	9534-350-001	9534-350-001	1
8	Motor & Gear Assembly 120 VAC	9914-137-015	9914-137-015	1
9	Screw -Hxwshrdsls, 6-32 x 3/16	9545-044-003	9545-044-003	6
10	Cross Recessed PAn Hd Tapping screw	9545-031-011	9545-031-011	4
11	Screw - hxwshdsl, 10-24 - 1.25f, ctd	9545-046-007	9545-046-007	4
12	Standoff-Wire	9527-007-001	9527-007-001	1
*	Rod, Door Lock	9497-225-011	9497-225-012	1

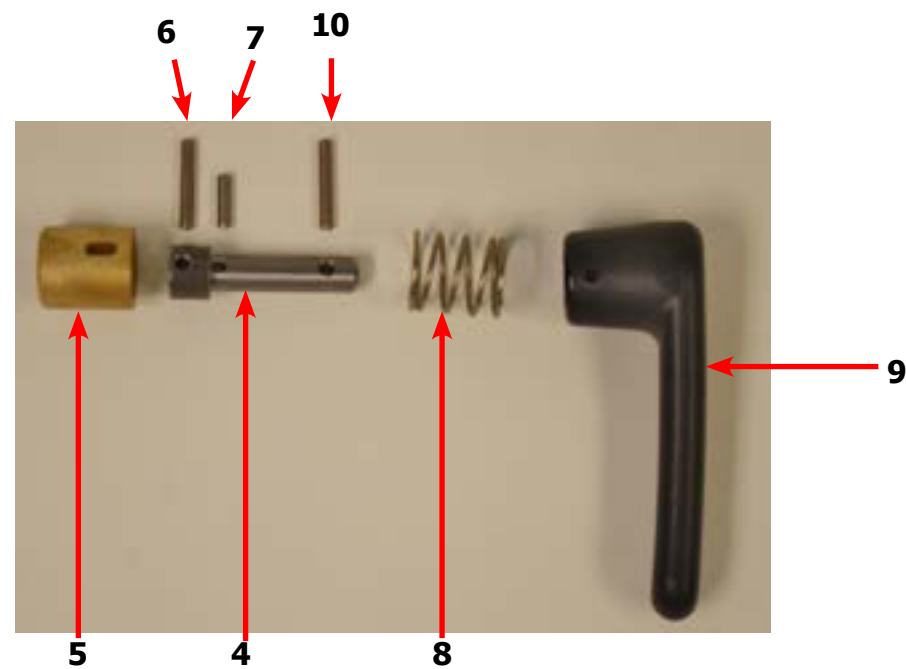
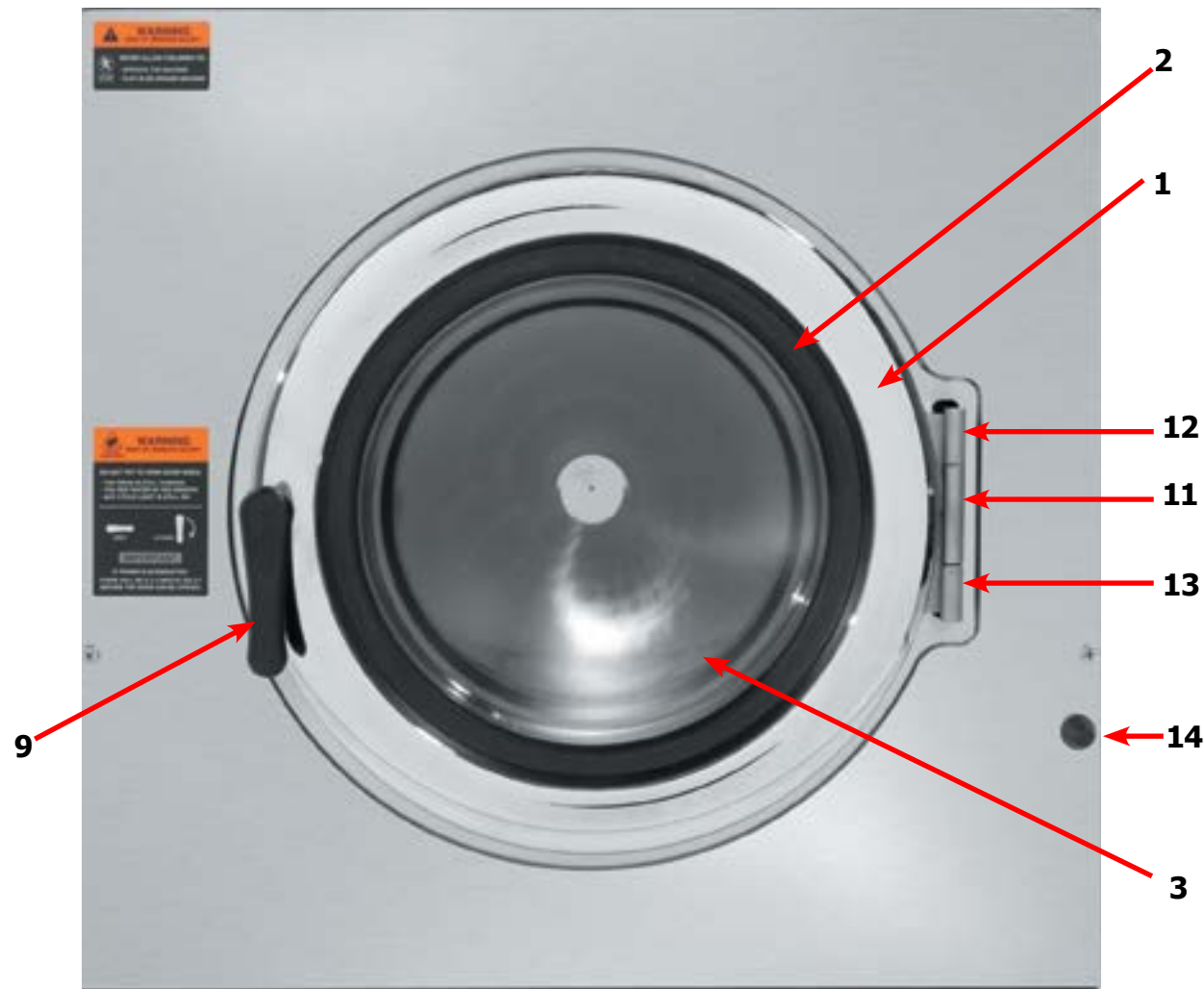

Loading Door Part # by Model

Key	Description	T-350	T-450	QTY
*	Loading Door, Complete #1-10	9960-308-001	9960-309-001	1
1	Loading Door, Ring	9487-264-002	9487-265-002	1
2	Gasket, Loading Door	9206-411-002	9206-419-001	1
3	Window, Loading Door	9635-018-001	9635-016-001	1
*	Shaft Assy, Locking (includes 4 thru 7)	9913-136-001	9913-136-001	1
4	Shaft, Door Locking	9537-195-002	9537-195-002	1
5	Cam, Locking	9095-051-001	9095-051-001	1
6	Pin, Groove (1 1/4)	9451-181-005	9451-181-005	1
7	Pin, Groove (3/4)	9451-181-004	9451-181-004	1
8	Spring, Lock Cam	9534-360-002	9534-360-002	1
9	Handle, Door	9244-091-001	9244-091-001	1
10	Pin, Door Handle (groove)	9451-181-005	9451-181-005	1
11	Door Hinge Assembly Mounts to Tub Front	9955-030-001	9955-030-001	
*	Shim, Loading Door Hinge (Thin)	9552-036-001	9552-036-001	2
*	Screw, 5/16-18x3/4	9545-014-009	9545-014-009	3
*	Lock Washer, 5/16	8641-582-009	8641-582-009	3
12	Leaf Assembly-Hinge, Top	9845-008-001	9845-008-001	1
13	Leaf Assembly-Hinge, Bottom	9845-005-002	9845-005-002	1
*	Screw, 5/16x5/8	9545-056-002	9545-056-002	3
14	Bumper-Loading Door	9051-055-001	9051-055-001	1
*	Nut, 1/4, 20UNC, 2B	8640-414-003	8640-414-003	1
15	Label, Warning-Door Opening (Black)	8502-757-001	8502-757-001	1
16	Label, Warning-Door Risk of Injury (Black)	8502-759-001	8502-759-001	

Loading Door Hinge 180 Degree Opening

Key	Description	T-350	T-450	QTY
1	Door Hinge Assembly (mounts to tub front)	9955-030-001	9955-030-001	1
*	Shim, Loading Door Hinge (Thin)	9552-036-001	9552-036-001	2
*	Screw, 5/16-18x3/4	9545-014-009	9545-014-009	3
*	Lock Washer, 5/16	8641-582-009	8641-582-009	3
2	Leaf Assembly-Hinge, Top	9845-008-001	9845-008-001	1
3	Leaf Assembly-Hinge, Bottom	9845-005-002	9845-005-002	1
4	Screw, 5/16x5/8	9545-056-002	9545-056-002	3
5	Switch, Door Hinge Close (Plunger)	9539-492-001	9539-492-001	1
6	Door Ring	9487-264-002	9487-265-002	1
7	Gasket, Door Glass	9206-411-002	9206-419-001	1
8	Window, Cloths	9635-018-001	9635-016-001	1
*	Bumper-Loading Door	9051-055-001	9051-055-001	1
*	Nut, 1/4, 20UNC, 2B	8640-414-003	8640-414-003	1

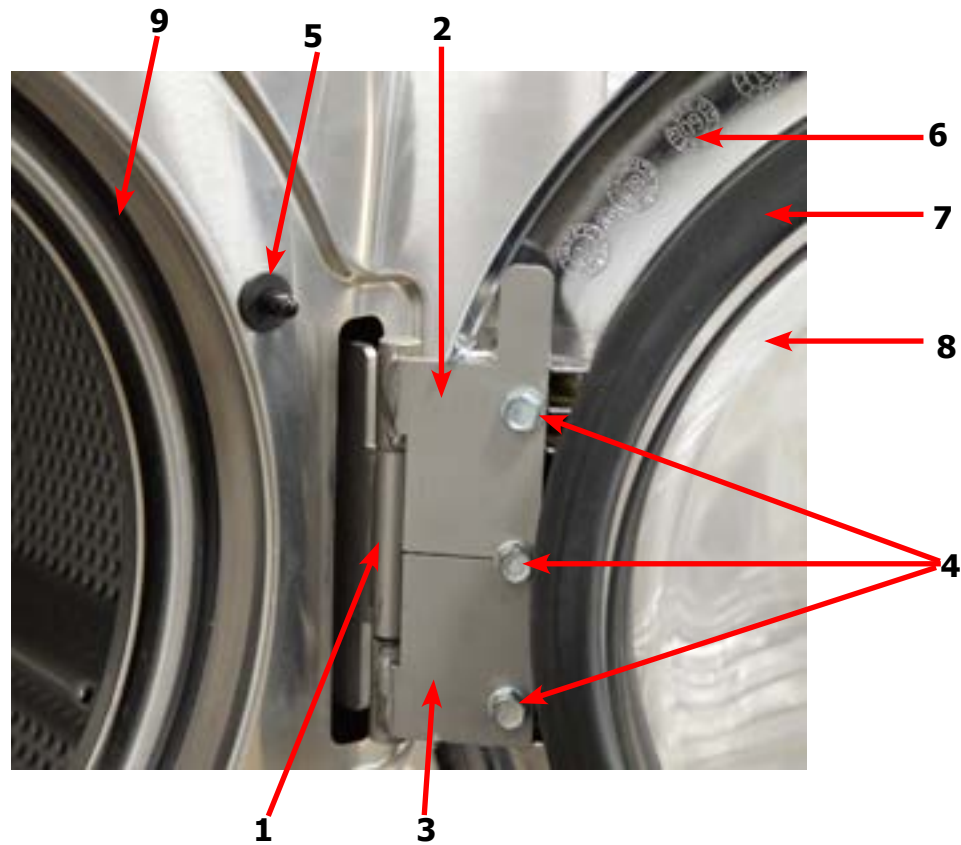

Water Inlet Valve Breakdown Part # by Model

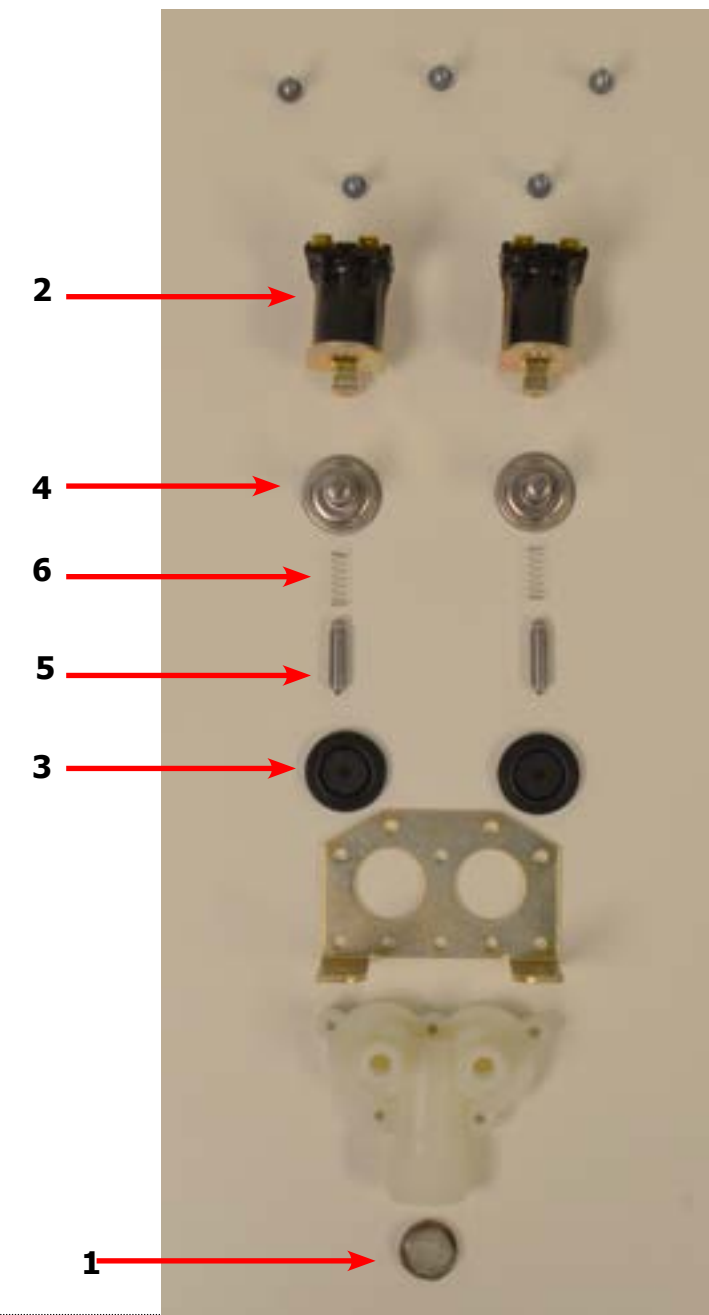

Key	Description	T-350	T-450	QTY
*	Valve, Water Inlet (includes 1 thru 6)	9379-183-012	9379-183-012	2
1	Screen, Inlet end of valve	9555-056-001	9555-056-001	2
2	Coil Assy., 120 V Invensys	9089-017-001	9089-017-001	2
*	Diaphragm Invensys (EPDM)	9118-049-001	9118-049-001	2
*	Diaphragm Invensys (Viton)	9118-049-002	9118-049-002	2
3	Diaphragm Invensys (EPDM NSF)	9118-049-003	9118-049-003	2
4	Guide, Solenoid Invensys	9211-021-002	9211-021-002	2
5	Armature Invensys	9015-008-001	9015-008-001	2
6	Spring, Armature Invensys	9534-298-001	9534-298-001	2

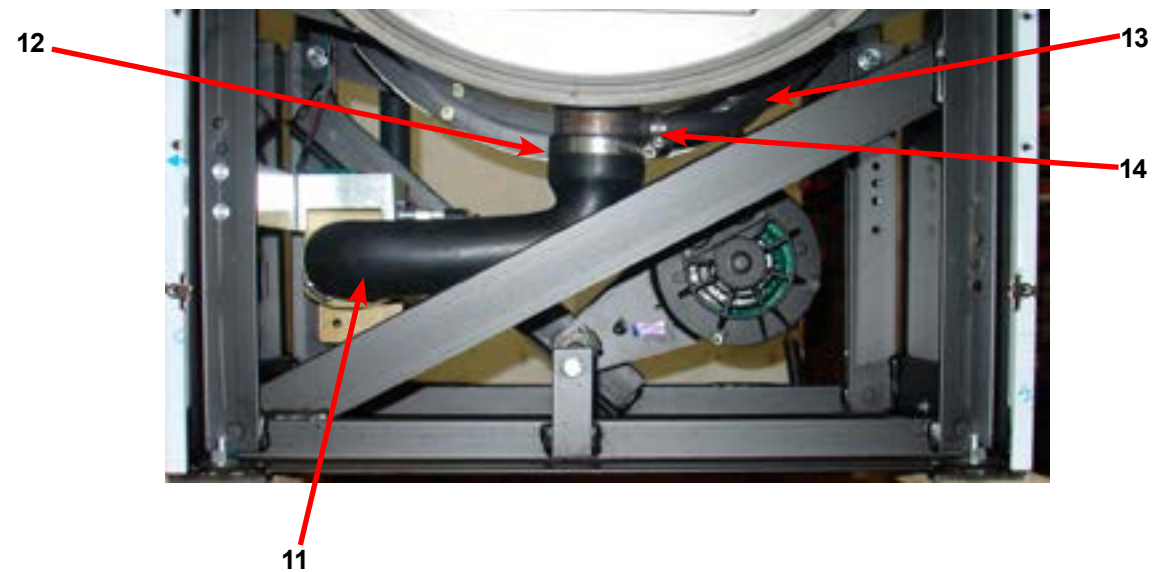
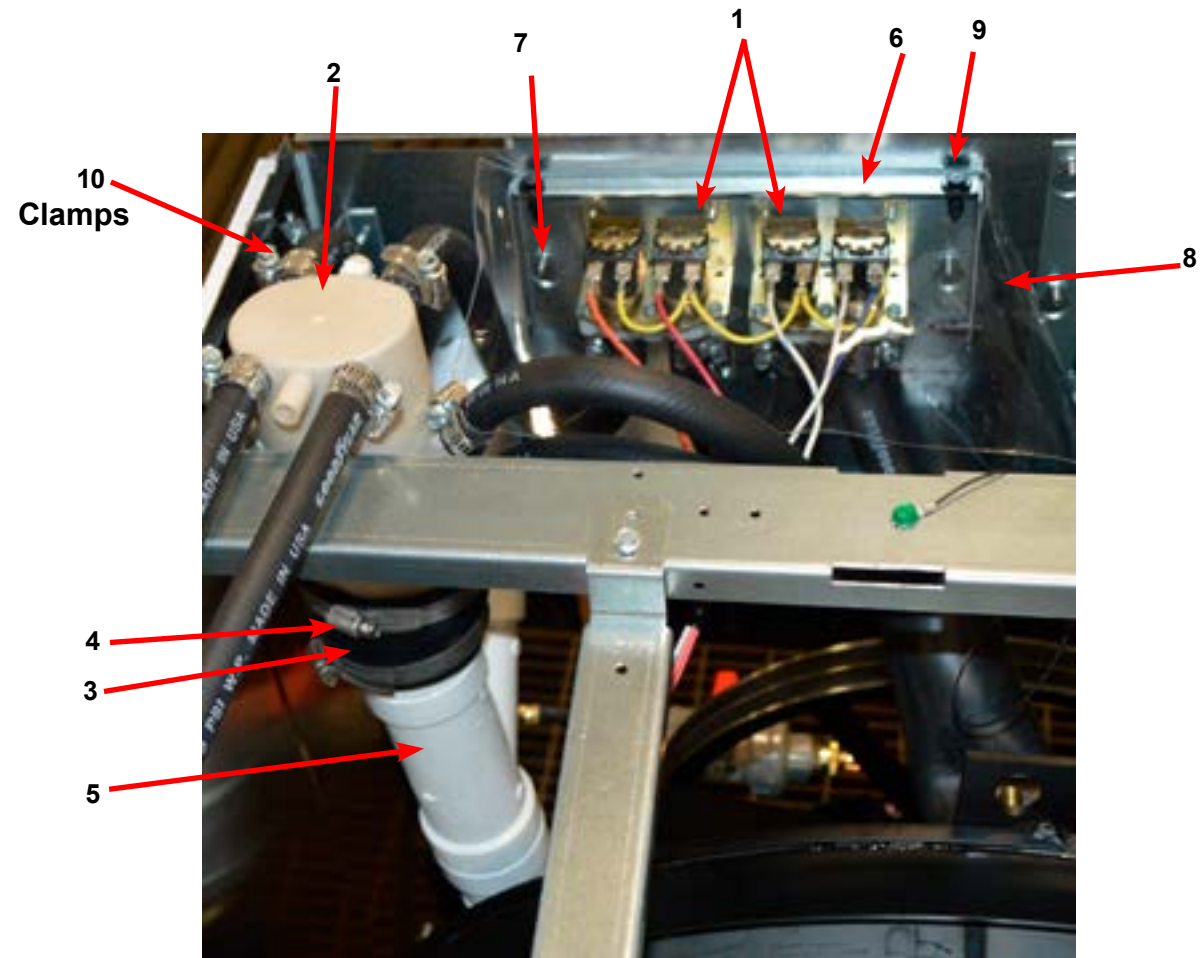

Water Inlet Part # by Model

Key	Description	T-350	T-450	QTY
1	Valve, Water Inlet (dual outlet) (see Water Inlet Valve Breakdown for individual parts)	9379-183-012	9379-183-012	2
*	Screw, Valve Mtg	9545-008-026	9545-008-026	4
2	Vacuum Breaker	9610-001-001	9610-001-001	1
*	Bracket, Vacuum Breaker	9029-266-001	9029-077-001	1
*	Screw	9545-008-026	9545-008-026	4
*	Hose, Vacuum Breaker to Tub	9242-458-001		1
*	Clamp, Tub End	8654-117-014		2
3	Hose, Vacuum Breaker to Injector		9242-461-001	1
4	Clamps		8654-117-014	1
5	Injector Assembly, Soap		9883-010-001	1
*	Hose, Injector to Tub Back		9242-462-001	1
*	Clamps		8654-117-014	1
*	Cap-Injector Assy		0935-127-001	1
*	Clamp		9242-117-014	1
6	Plate-Water Valves	9452-813-001	9452-813-001	1
7	Nut-Elastic stop, #10-32	8640-413-002	8640-413-002	2
8	Shield over Water Valves Plastic	9550-194-001	9550-194-001	1
9	Clip Push on	9083-121-001	9083-121-001	2
*	Hose, Bulk 1/2" I.D.	9242-453-001	9242-453-001	AR
10	Clamp, Hose-Worm	8654-117-015	8654-117-015	12
*	Flow restrictor	9475-002-002	9475-002-002	2
*	Dispenser, Soap	9122-005-004	9122-005-004	1
*	Gasket, Dispenser	9206-416-001	9206-416-001	1
*	Nut, Spring-SS	8640-399-007	8640-399-007	4
*	Screw, Disp. Mtg	9545-008-012	9545-008-012	4
11	Hose Tub to Drain Valve	9242-468-001	9242-456-001	1
12	Clamp	8654-117-014	8654-117-014	1
13	Hose, Pressure Switch	9242-175-000	9242-175-007	1
14	Clamp, Pressure Switch Hose	8654-117-015	8654-117-015	1

Chassis and Drain Part # by Model

Key	Description	T-350	T-450	QTY
1	Base Assy,Frame	9945-119-002	9945-141-002	1
2	Outer Tub Assy	9930-160-001	9930-122-001	1
*	Tub & Cylinder Assy	9869-029-001	9869-031-001	1
3	Ring Assy, Tub Mtg-Front	9950-057-002	9950-051-004	1
4	Ring Assy.Clamp Tub Mtg.- Rear	9950-046-002	9950-056-002	1
5	Bolt, 1/2" x 1 1/4 Rings to Base	9545-017-012		4
6	Nut, Wizlock, 1/2-13	8640-417-005	8640-417-005	1
7	Hose, Tub to Drain Valve	9242-468-001	9242-456-001	1
8	Clamp, Hose (Tub to Drain Valve)	8654-117-014	8654-117-014	2
9	Valve, Drain	9379-199-001	9379-202-001	1
10	Hose, Drain Valve to Tube	9242-451-002	9242-457-001	1
11	Clamp, Hose (Drain Valve to Tube)	8654-117-014	8654-117-014	2
12	Bracket, Drain Valve	9029-005-001		1
*	Screw, Valve to Bracket 12ABx1/2	9545-008-026		2
13	Tube Assy, Drain	9915-125-002	9915-119-002	1
*	Screw Tube (Bracket to Base 1/4Bx3/4	9545-030-002	9545-030-002	2
14	Hose, Overflow to drain	9242-449-002	9242-449-002	1
*	Clamp, Overflow	8654-117-018	8654-117-018	2
*	Shim, Support Assembly (thin)	9552-038-003	9552-036-001	AR
15	Injection Tube		9883-010-001	1
*	Hose-Inlet, Water	9242-458-001		1
16	Dispenser Soap	9122-005-004	9122-005-004	1
17	Gasket, Dispenser	9206-416-001	9206-416-001	1
*	Nut Spring SS	8640-399-007	8640-399-007	4
*	Screw, Disp. Mtg	9545-008-012	9545-008-012	4
*	Hose, Dispenser to Tub	9242-450-002	9242-450-002	1
*	Clamp, Dispenser Hose	8654-117-008	8654-117-008	2
18	Back Ass'y, Tub	9962-016-001	9962-013-002	1

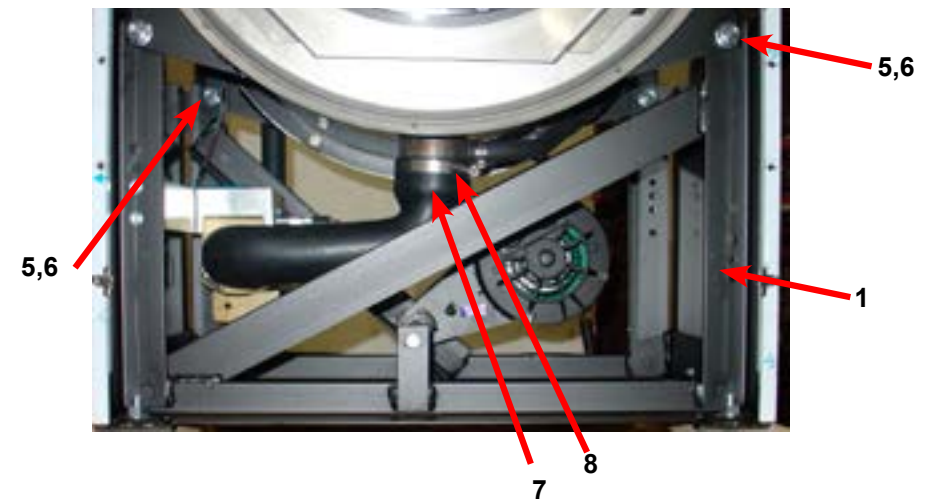
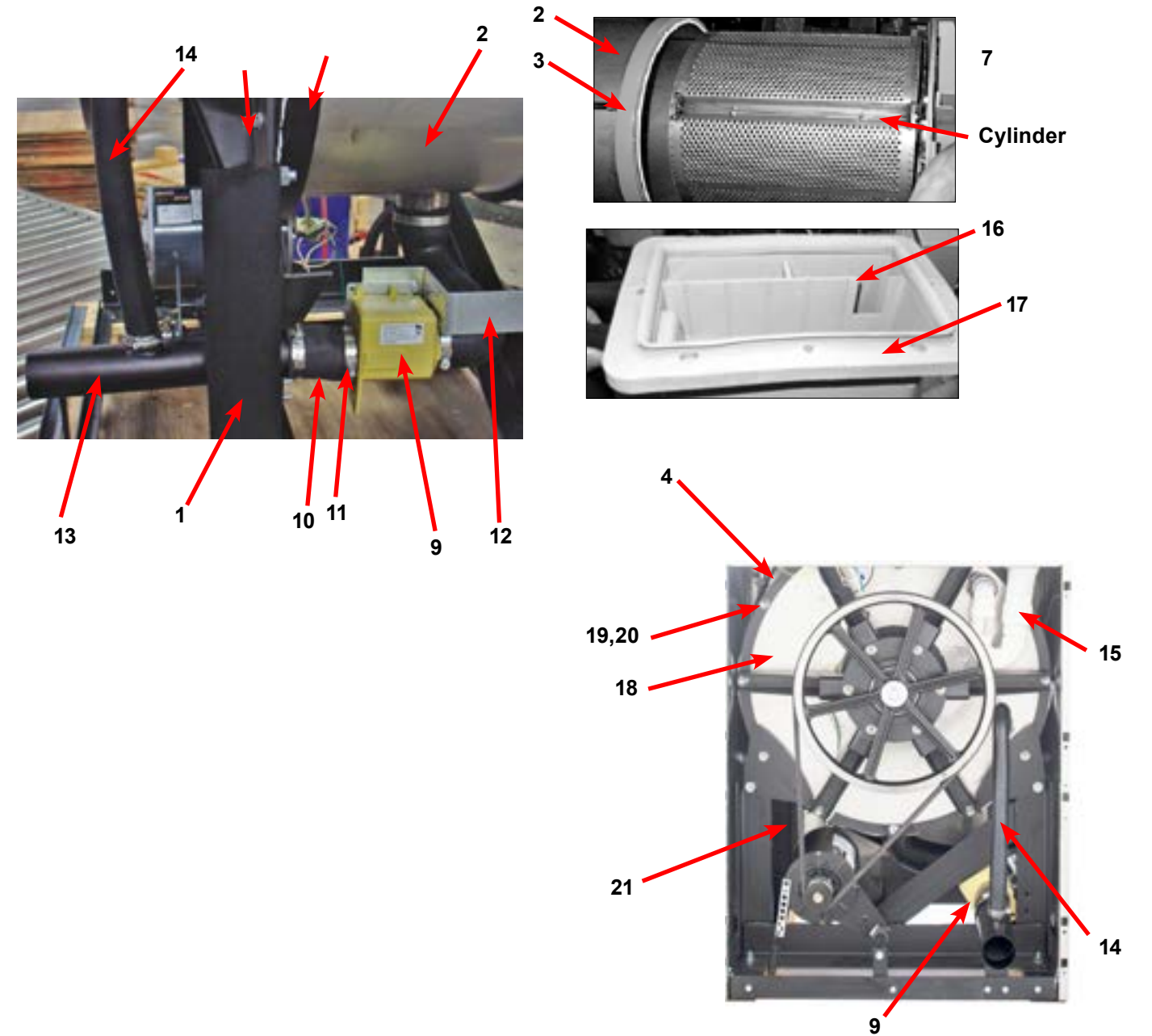

Electrical Components - Top Compartment 208/240VAC

Key	Description	T-350	T-450	QTY
*	Control Trough Assembly	9857-241-001	9857-242-001	1
1	Trough Assembly	9839-020-001	9839-020-001	1
2	Transformer, Dual Secondary	8711-017-001	8711-017-001	1
*	Screw, #10B x 1/2	9545-008-026	9545-008-026	4
*	Lockwasher #10	8641-582-006	8641-582-006	4
3	Terminal Block, Power	9897-026-005	9897-026-005	2
*	Screw, #8AB x 1/2	9545-045-012	9545-045-012	4
4	Wiring harness, Graphic Control	9627-922-002	9627-922-002	1
5	PCB Assembly, Main Control	9799-027-001	9799-027-001	1
6	PCB Assembly, Relay	9799-028-001	9799-028-001	2
*	Screw, #10B x 1/2	9545-008-026	9545-008-026	12
7	Wiring Harness, Main	9627-933-002	9627-933-002	1
8	Wiring Harness, Chemical Injection	9627-927-001	9627-927-001	1
9	Wire Assembly, Model Designator	8220-158-005	8220-158-011	1
10	Wiring Harness, VFD	9627-928-002	9627-928-002	1
*	Cable Clamp, 3/16"	8654-125-005	8654-125-005	1
*	Screw, 8B x 1/4"	9545-045-001	9545-045-001	1
11	Wiring Harness, Control / Relay	9627-921-001	9627-921-001	2
*	Wire Assembly, Relay PCB	8220-159-005	8220-159-005	1
*	Wire Assembly, Relay PCB	8220-159-006	8220-159-006	1
*	Screw, 10-32T x 1/2 Green	9545-008-027	9545-008-027	2
*	Lockwasher #10	8641-582-006	8641-582-006	2
*	Standoff, Twist lock	9527-002-002	9527-002-002	4
14	Pressure Switch	9732-315-001	9732-315-001	1
*	PCB Support, 3/8"	9548-285-001	9545-285-001	4
15	Wiring Harness, Pressure Switch	9627-926-002	9627-926-002	1
16	Wire Assembly, Orange 7-1/2"	8220-062-052	8220-062-052	1
17	Wire Assembly, White / Orange 9"	8220-062-053	8220-062-053	1
18	Fuse Holder Assembly	9200-001-002	9200-001-002	2
19	Fuse, 2 Amp Slow, 1/4 x 1-1/4	8636-018-005	8636-018-005	1
20	Fuse, 1.5 Amp Fast, 1/4 x 1-1/4	8636-018-001	8636-018-001	1
*	Label, Fuse 2.5 Amp	8502-716-002	8502-716-002	1
*	Label, Fuse 1.5 Amp	8502-716-001	8507-716-001	1
21	Wire Assembly, Red 7-1/2"	8220-062-059	8220-062-059	2
22	Wire Assembly, Orange 7-1/2"	8220-062-052	8220-062-052	2
*	Label, Water Level Settings	8502-775-001	8502-775-001	1
24	Wiring Harness, Power Supply	9627-923-001	9627-923-001	1

Electrical Components - Top Compartment

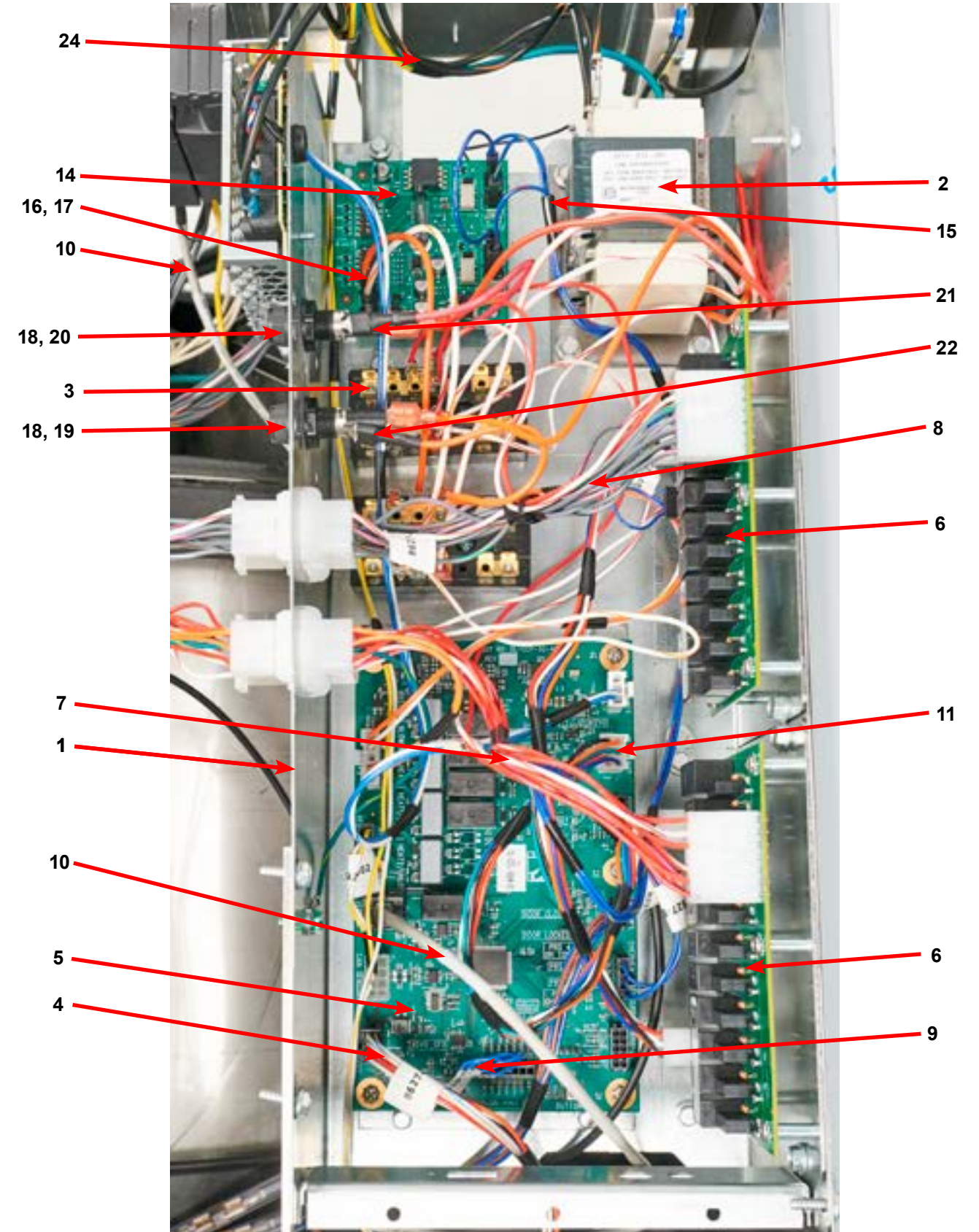

Control Panel Part # by Model

Key	Description	T-350	T-450	QTY
1	Panel Control Assembly (panel only)	9989-598-001	9989-598-001	1
*	Screw, Hxwshrhdundct #10Bx 1/2" (Control to sides)	9545-008-026	9545-008-026	4
*	Plate-Latch, Top	9452-625-001	9452-625-001	1
*	Nut, #8-32	8640-412-005	8640-412-005	2
*	Post Locator Top	9467-024-001	9467-024-001	2
*	Nut Hexkeps #6-32	8640-411-003	8640-411-003	2
*	Locator Panel	9355-001-001	9355-001-001	2
*	Screw FillHDCR 10Bx1/2" Guide	9545-008-023	9545-008-023	2
	Shield, PCB	9550-184-001	9550-184-001	1
	Nut, #8-32	8640-412-005	8640-412-005	3
2	Pushbutton Control (Black)	9035-063-001	9035-063-001	1
3	Window-Display LCD w/Gasket	9635-021-002	9635-021-002	1
4	PCB assembly Display	9857-230-003	9857-230-003	1
5	Nut Elasticstop #6-32	8640-411-003	8640-411-003	4
6	Cable Assy. USB	9806-024-001	9806-024-001	1
*	Harness Doorlock, Switches	9627-936-002	9627-936-002	1
*	Harness, P5/Pressure Switch	9627-926-002	9627-926-002	1
*	Kit-Emergency Stop, O-Series (includes #X, #Y)	9732-223-004	9732-223-004	1
7	Button- Emergency Stop, w/Latch	9035-061-002	9035-061-002	1
8	Spacer Plastic #8x1/8	8640-412-005	8640-412-005	2
9	Plate-Mounting E-Stop Button	9452-725-001	9452-725-001	1
10	Nut Hexeeps #8-32	8640-412-005	8640-412-005	2
11	Switch-Contact Block, DPST, NC	9539-499-001	9539-499-001	1
*	Nameplate,Control Panel (Black)	9412-241-001	9412-242-001	1
12	Motor Ass'y, Door Locking (see Door Lock Group for parts breakdown)	9892-015-003	9892-015-003	1
13	Thermoactuator - 24VAC	9586-001-003	9586-001-003	2
14	Hex Nuts (mounting Door Lockassy. to control panel)	8640-412-005	8640-412-005	4
15	Nut-Spring	8640-399-008	8640-399-008	2
16	Screw, #10B x 1/2	9545-008-026	9545-008-026	2

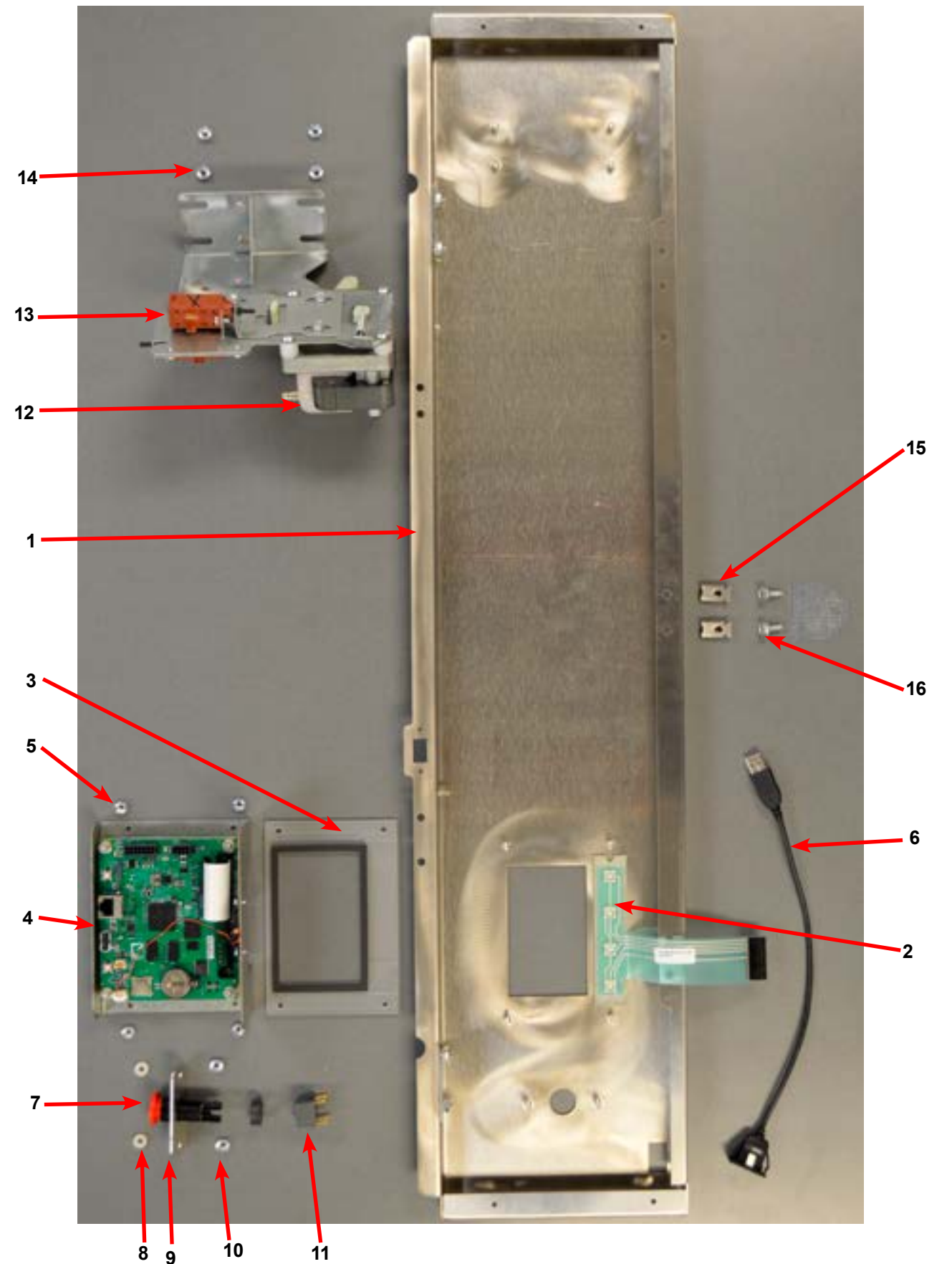

T-350 Express 208-240 Wiring Informitive

WIRING DIAGRAM 208 - 240V, 1/3PH, 60HZ

P/N 9507-015-001PR
20 LB OPL EXPRESS, VF DRIVE
WINDSOX_12.0.X

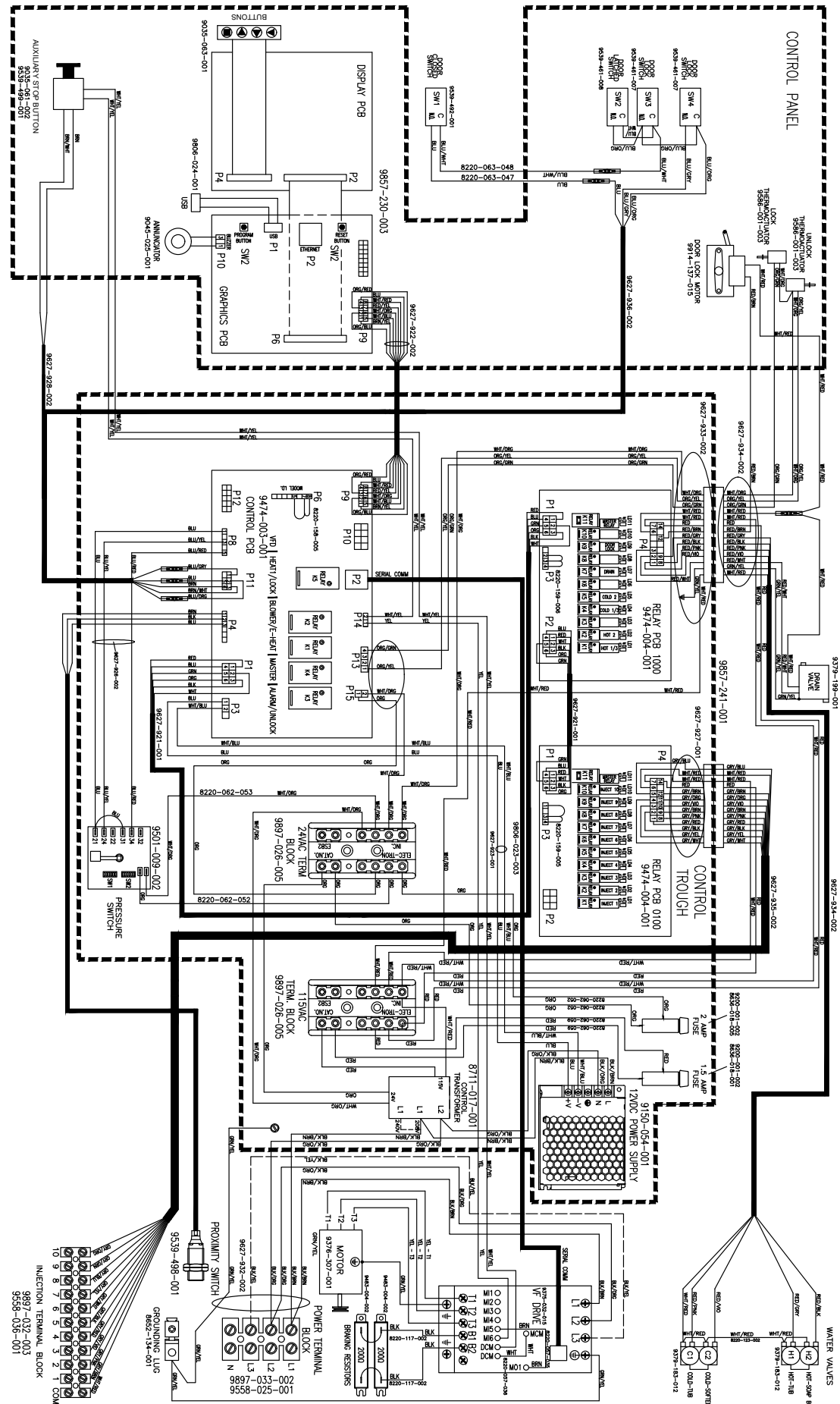

T-450 Express 208-240 Wiring Informitive

WIRING DIAGRAM 208 - 240V, 1/3PH, 60HZ

P/N 9507-016-001PR
30 LB OPL EXPRESS, VF DRIVE
WINDSOX_12.0.X

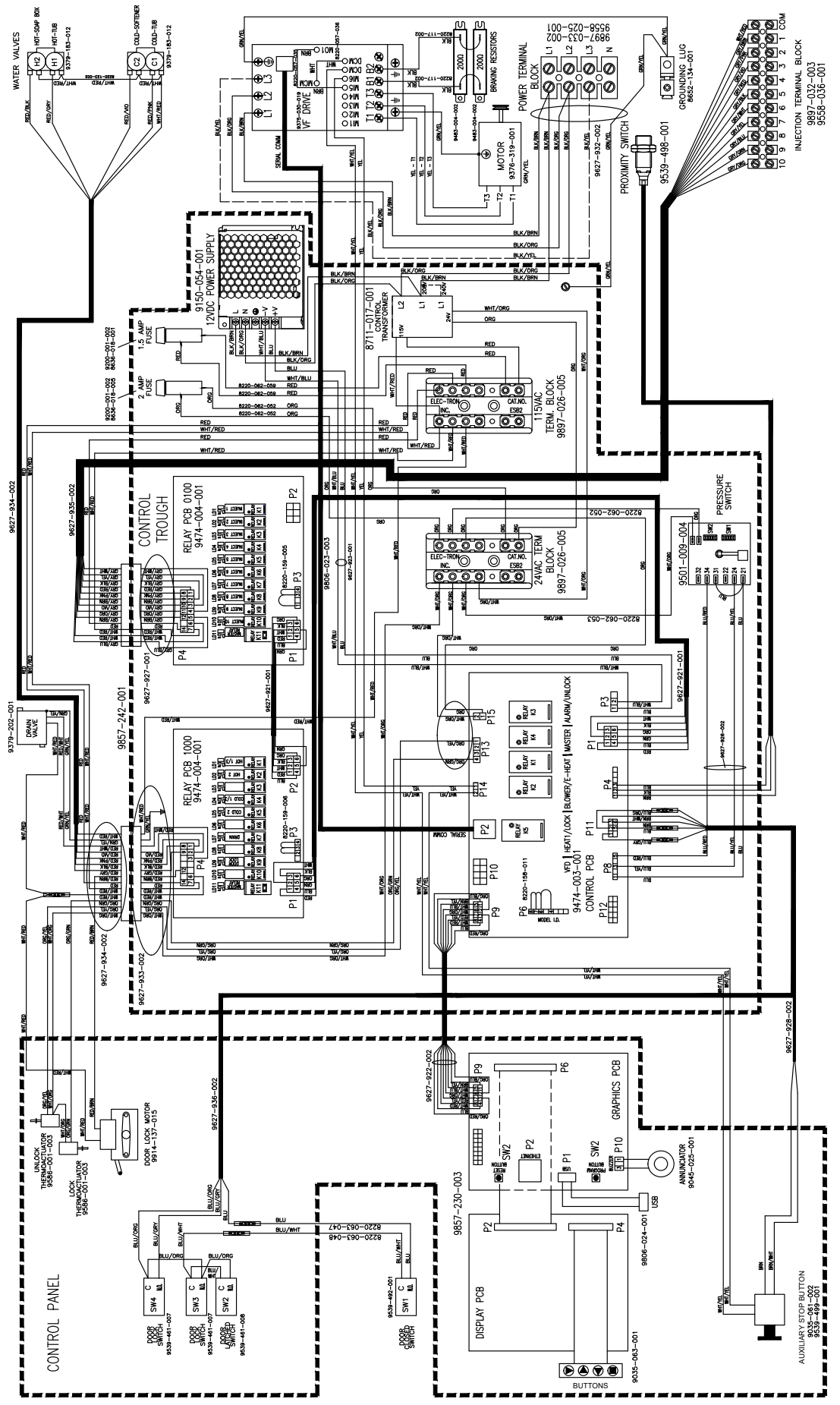

Transformer, Electrical -39 models

Key	Component	T-350	T-450	QTY
*	Operators Manual	8514-237-002	8514-239-002	
*	Wiring Schematic & Diagram	9506-553-001	9506-553-001	1
*	Controls Assembly - Trough,	9857-211-002	9857-213-002	1
*	Wiring Harness, Power Terminal Block	9627-747-006	9627-747-006	1
1	Circuit Breaker	5198-211-002	5198-211-002	1
*	Instructions, Transformer Connect	8507-230-003	8507-230-003	1
2	Controls Transformer	8711-004-003	8711-004-003	1
3	Transformer	8711-009-003	8711-009-003	1
*	Terminal Strip Marker	9558-028-002	9558-028-002	1

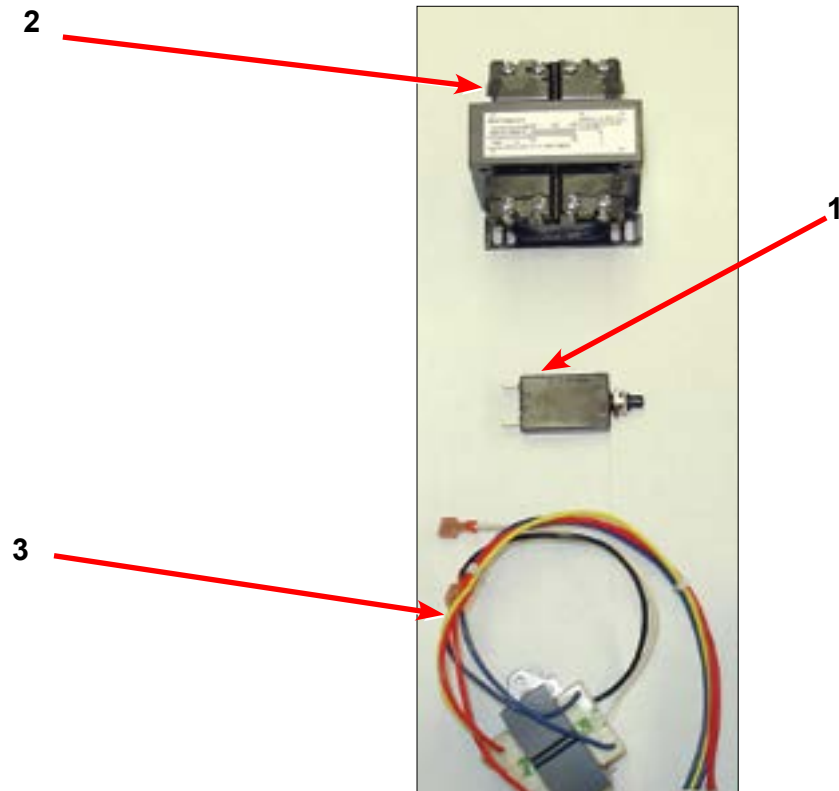

Water Valve, Drain Valve -39 models

Key	Component	T-350	T-450	QTY
1	Water Valve	9379-183-013	9379-183-013	2
2	Drain Valve 2" inch	9379-199-002		1
3	Drain Valve 3" inch		9379-202-002	1

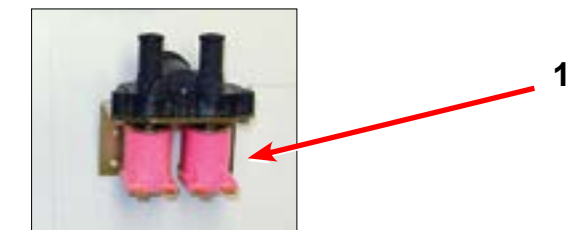
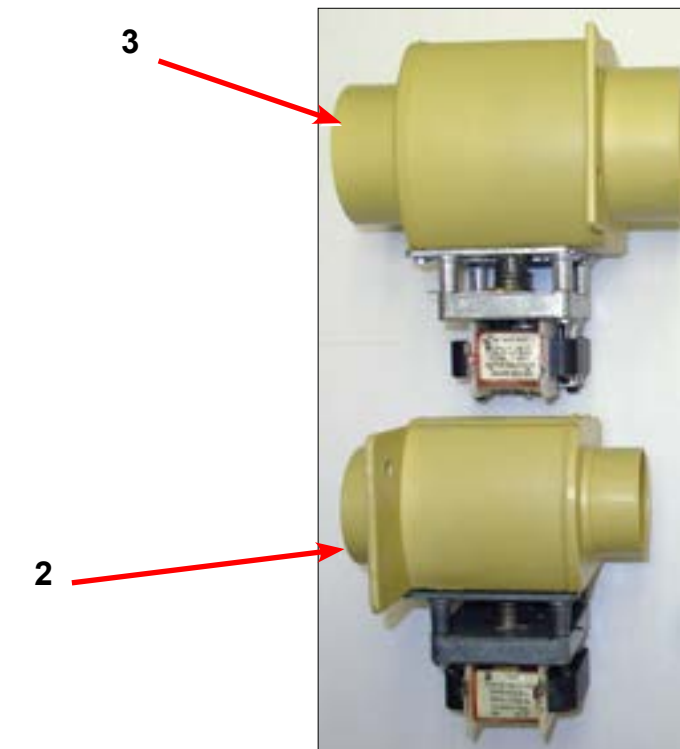

T-350 -39 O1 Diagram

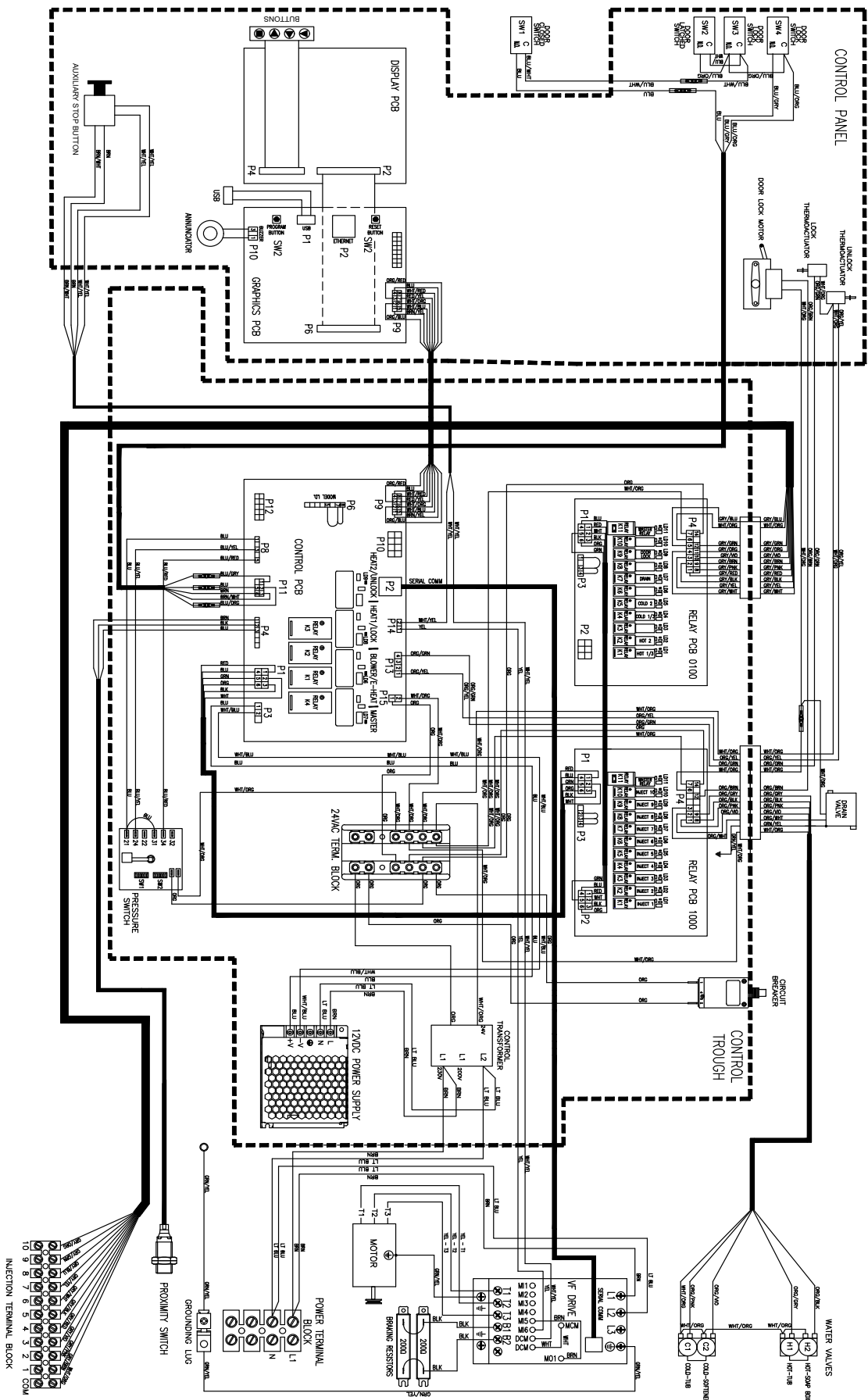

WIRING DIAGRAM 230 - 240V, 1PH, 50HZ

P/N 9507-025-001PR
20 LB OPL EXPRESS, VF DRIVE
WHD350X-38.0.X-1-X

T-350 -39 O1 Schematic

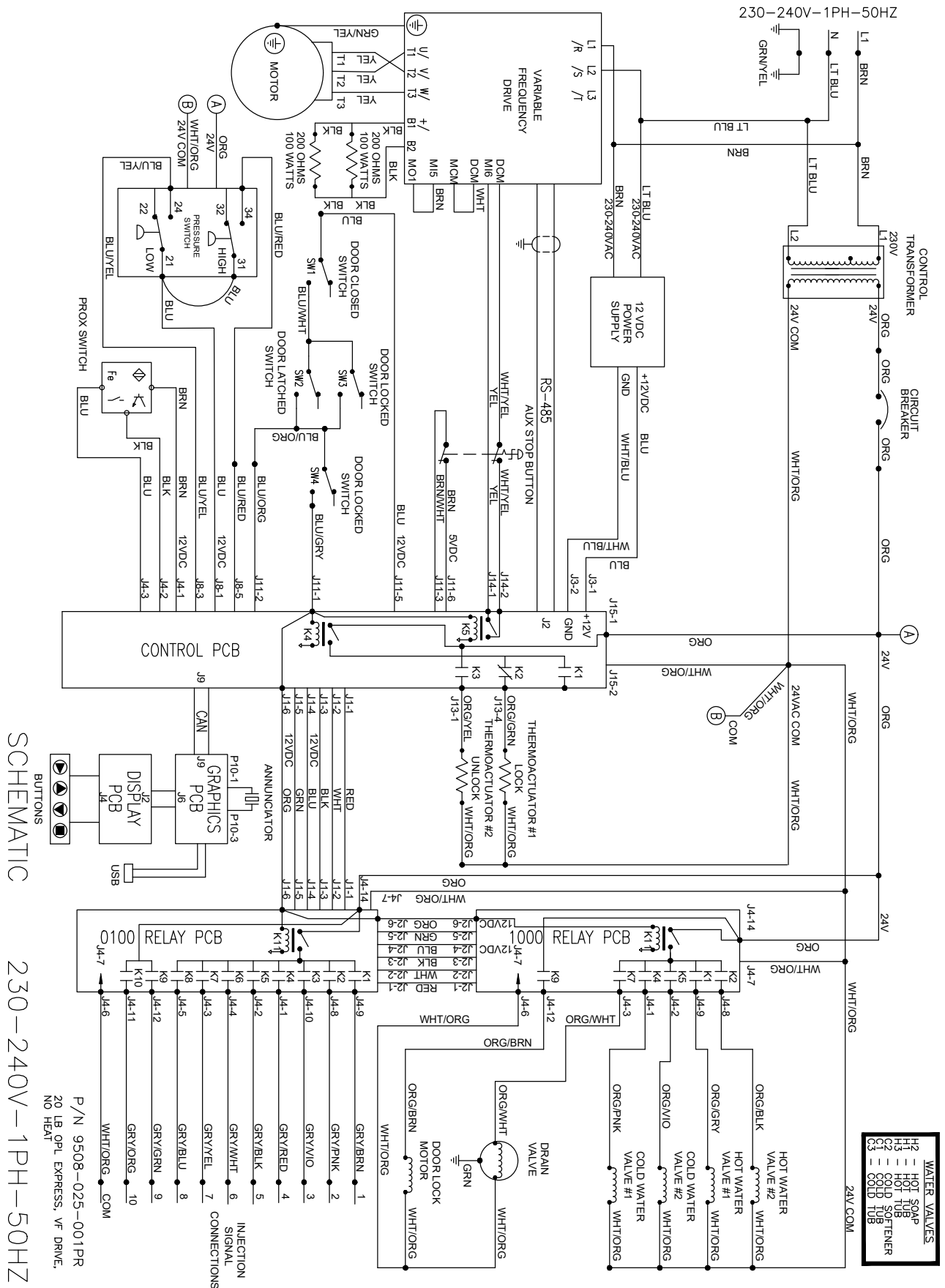

WATER VALVES
 H1 - HOT WATER VALVE #1
 H2 - HOT WATER VALVE #2
 C1 - COLD WATER VALVE #1
 C2 - COLD WATER VALVE #2

SCHEMATIC

230-240V-1PH-50HZ

P/N 9508-025-001PR
20 LB OPL EXPRESS, VF DRIVE,
NO HEAT

T-350 -39 O2 Diagram

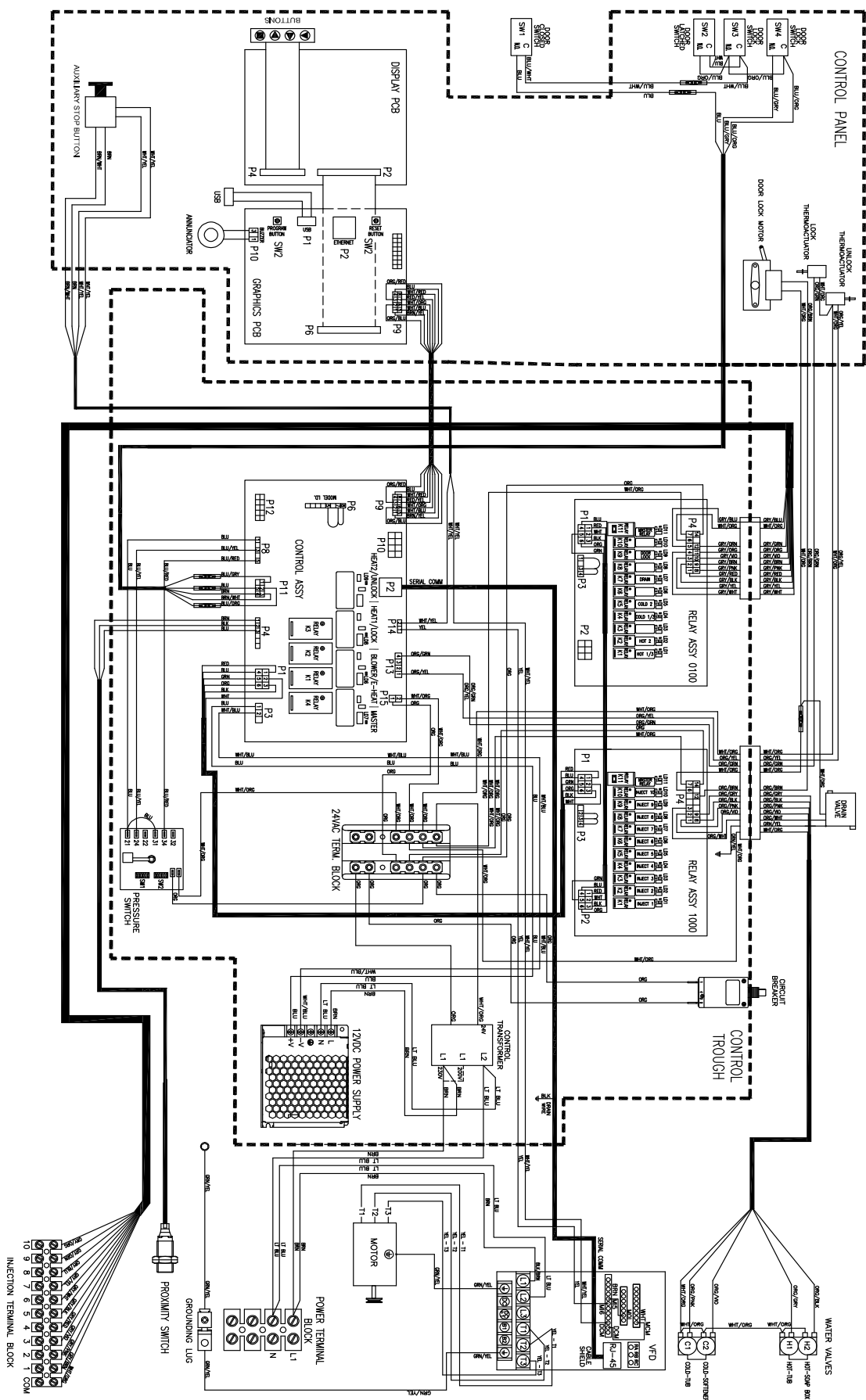

WIRING DIAGRAM 230 - 240V, 1PH, 50HZ

P/N 9507-064-001PR
20 LB OPL EXPRESS, VF DRIVE
NO HEAT
WMS030X-39_03X-1-X

T-350 -39 O2 Schematic

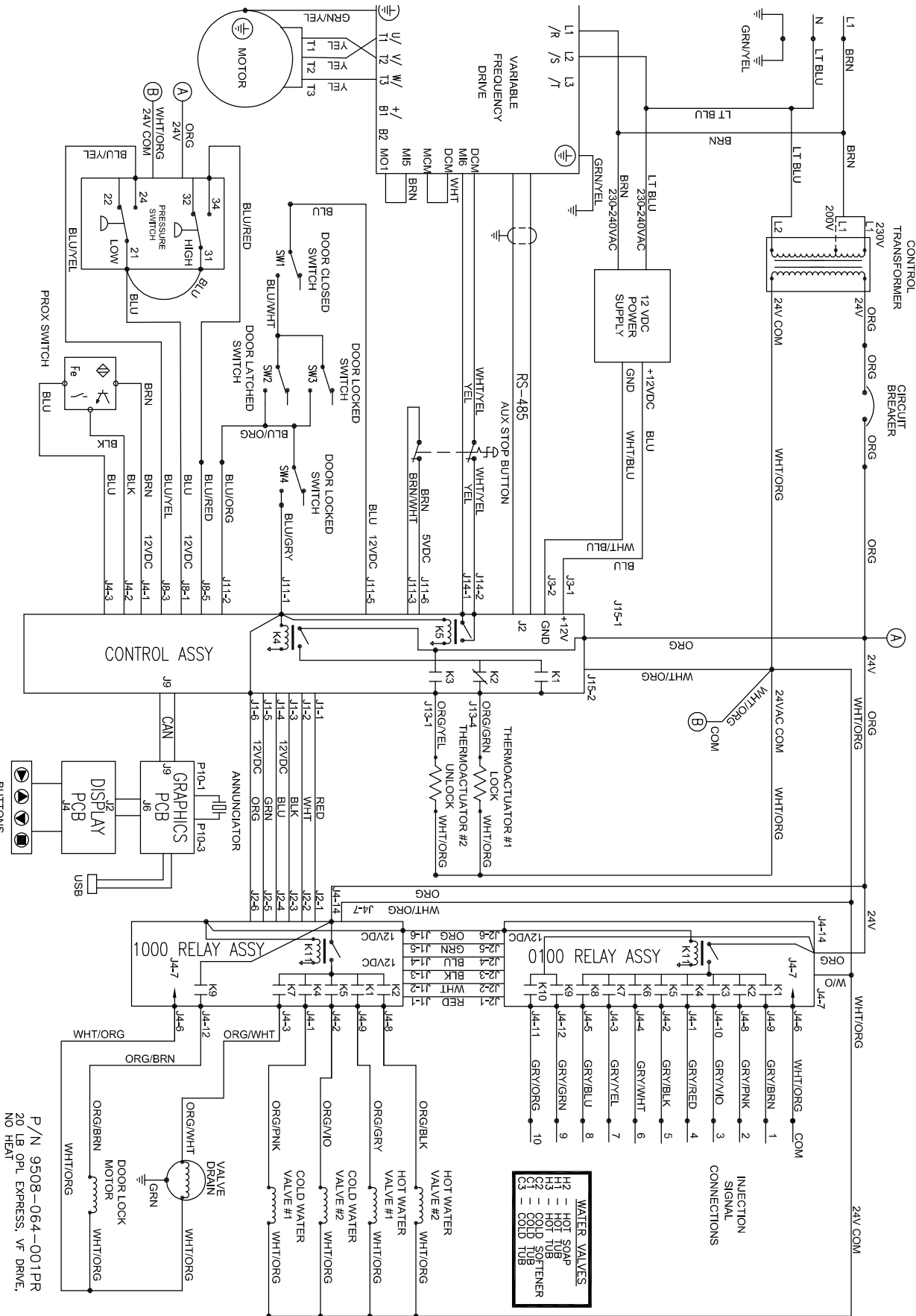

SCHEMATIC

230-240V-1PH-50HZ

P/N 9508-064-001PR
20 LB OPL EXPRESS, VF DRIVE,
NO HEAT

T-450 -39 O1 Diagram

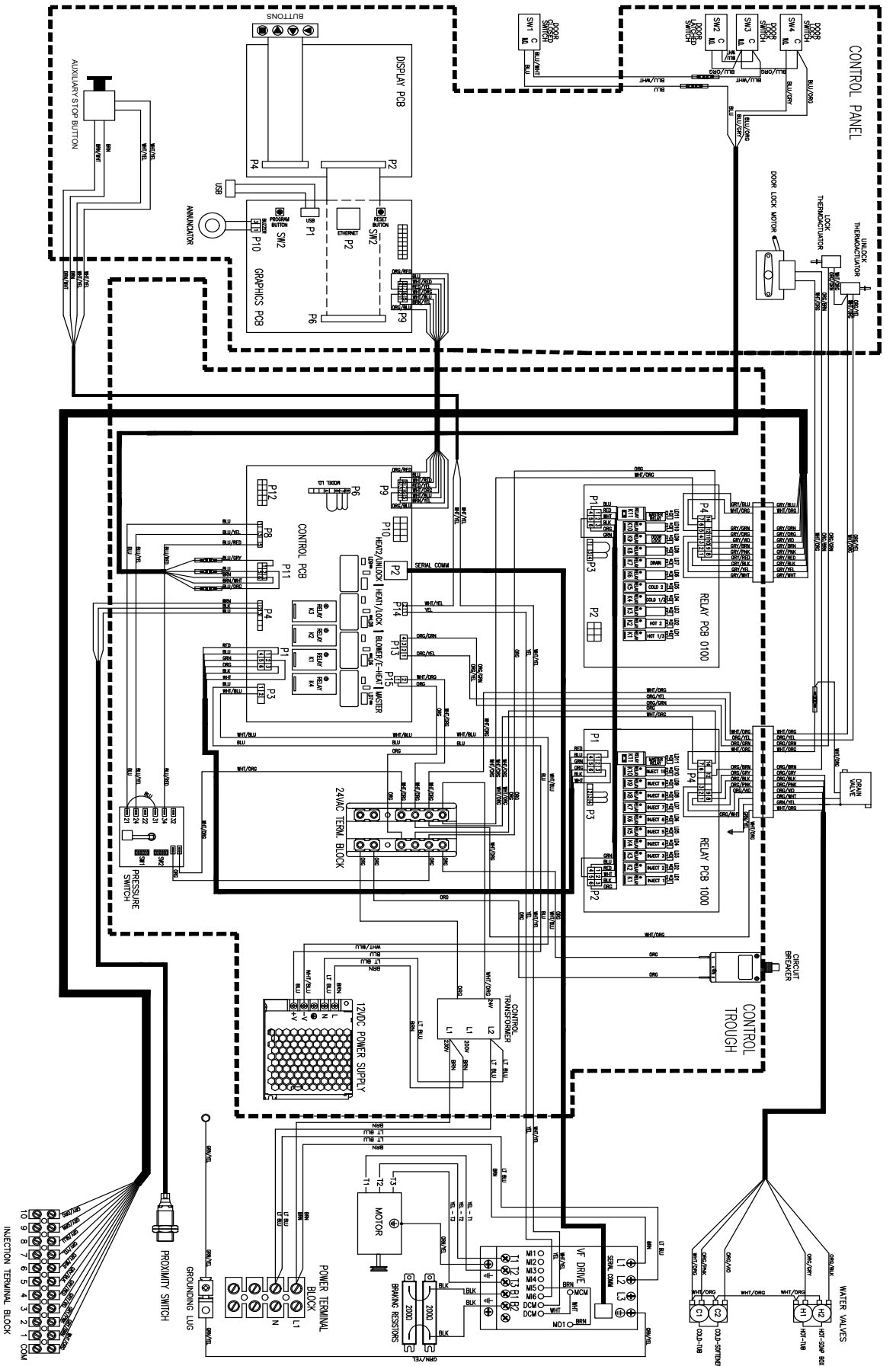

WIRING DIAGRAM 230 - 240V, 1PH, 50HZ

P/N 9507-026-001PR
30 LB OPL EXPRESS, VF DRIVE
NO HEAT
WHD050A-39_0_X-_-_-X

T-450 -39 O1 Schematic

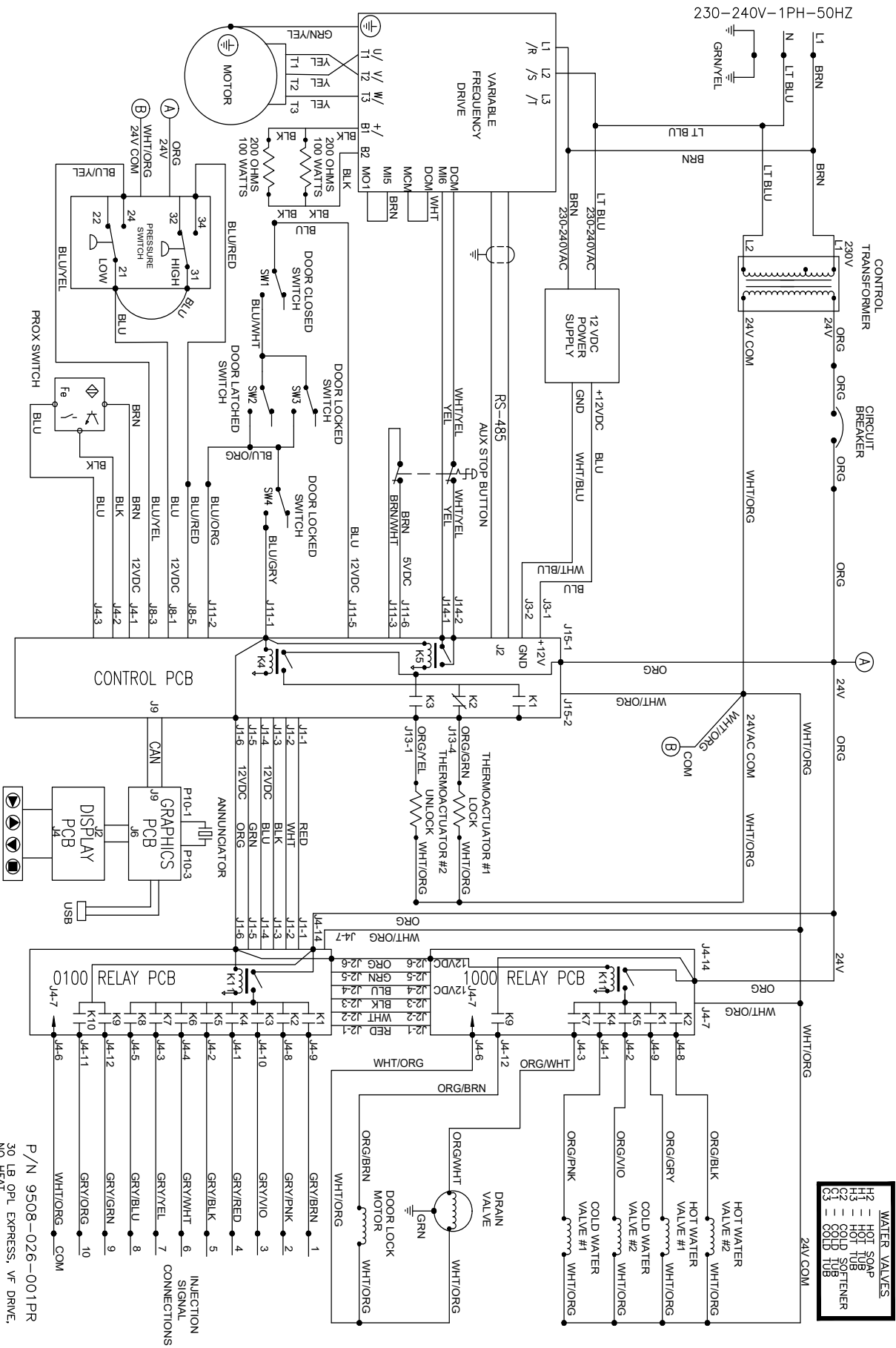

WATER VALVES	
H1	HOT SOLENOID
H2	HOT TUB SOLENOID
H3	HOT TUB SOLENOID
C1	COLD SOLENOID
C2	COLD TUB SOLENOID
C3	COLD TUB SOLENOID

SCHEMATIC

230-240V-1PH-50HZ

P/N 9508-026-001PR
30 LB OPL EXPRESS, VF DRIVE,
NO HEAT

T-450 -39 O2 Diagram

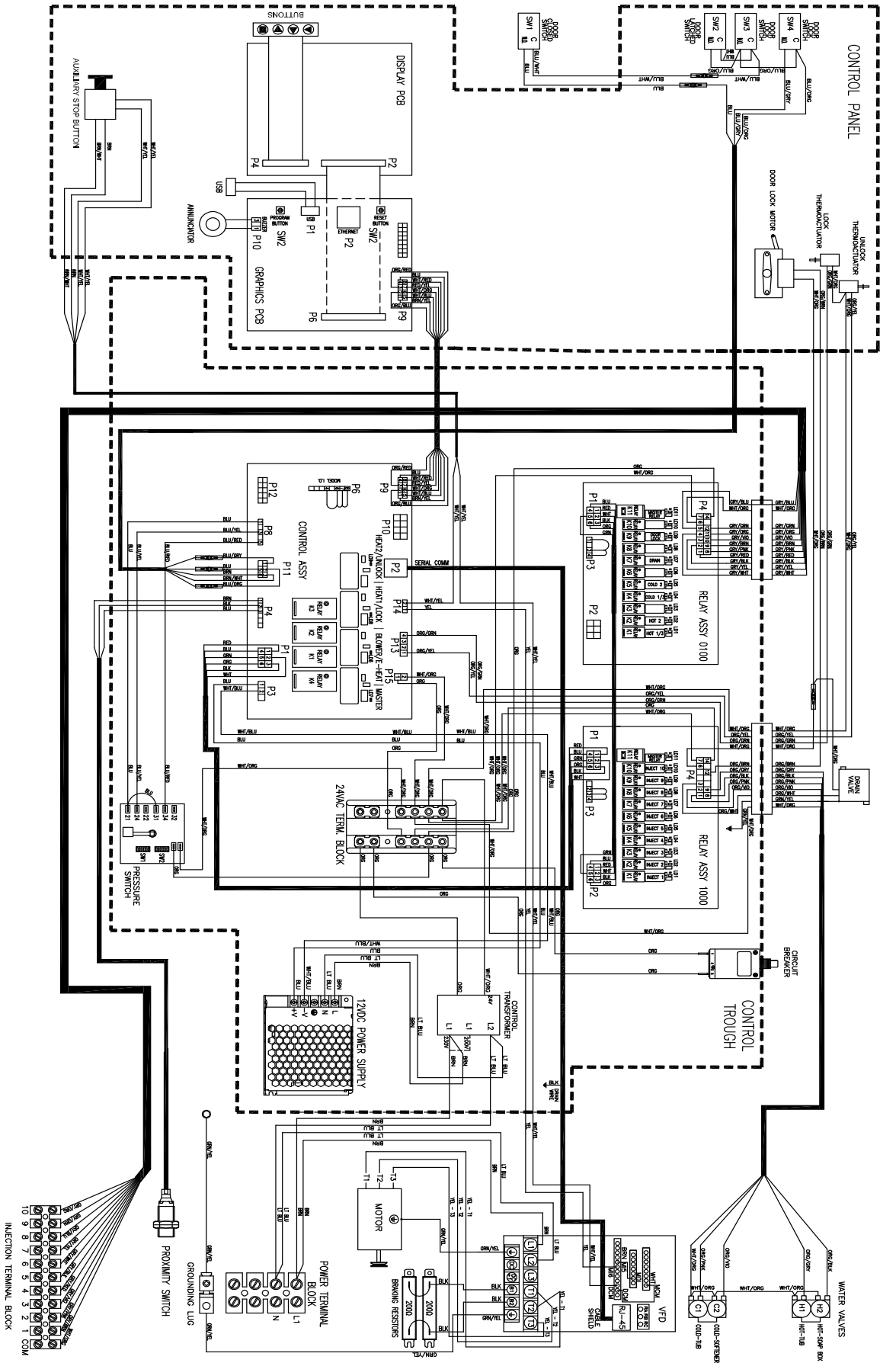

WIRING DIAGRAM 230 - 240V, 1PH, 50HZ

P/N 9507-065-001PR
30 LB OPL EXPRESS, VF DRIVE
NO HEAT
WINDBOX -39, 02V- X

T-450 -39 O2 Schematic

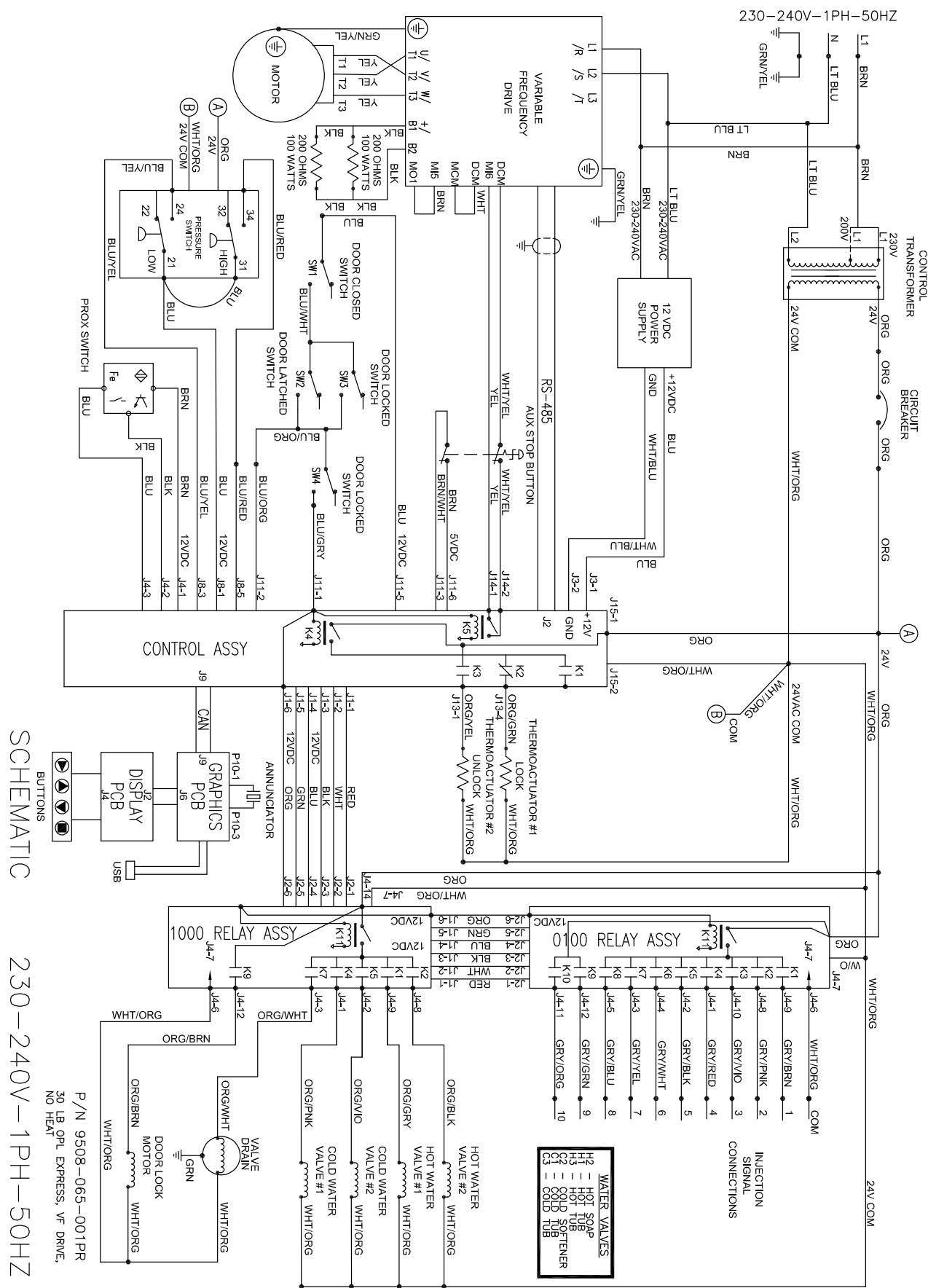

SCHEMATIC

230-240V-1PH-50HZ

P/N 9508-065-001PR
30 LB OPL EXPRESS, VF DRIVE,
NO HEAT



Section :10

Maintenance

Preventative Maintenance

Daily

- Step 1:** Check that the loading door remains securely locked and cannot be opened during an entire cycle.
- Step 2:** Clean the top, front, and sides of the cabinet to remove residue.
- Step 3:** Clean the soap dispenser and lid and check that all dispenser mounting screws are in-place and tight.
- Step 4:** Check the loading door for leaks. Clean the door seal of all foreign matter.
- Step 5:** Leave the loading door open to aerate the washer when not in use.

Quarterly

- Step 1:** Make sure the washer is inoperative by switching off the main power supply.
- Step 2:** Check the V-belts for wear and proper tension.
- Step 3:** Clean lint and other foreign matter from around motor.
- Step 4:** Check all water connections for leaks.
- Step 5:** Check the drain valve for leaking and that it opens properly.
- Step 6:** Wipe and clean the inside of the washer and check that all electrical components are free of moisture and dust.
- Step 7:** Remove and clean water inlet hose filters. Replace if necessary.
- Step 8:** Check anchor bolts. Retighten if necessary.