

230V-1PH-50HZ

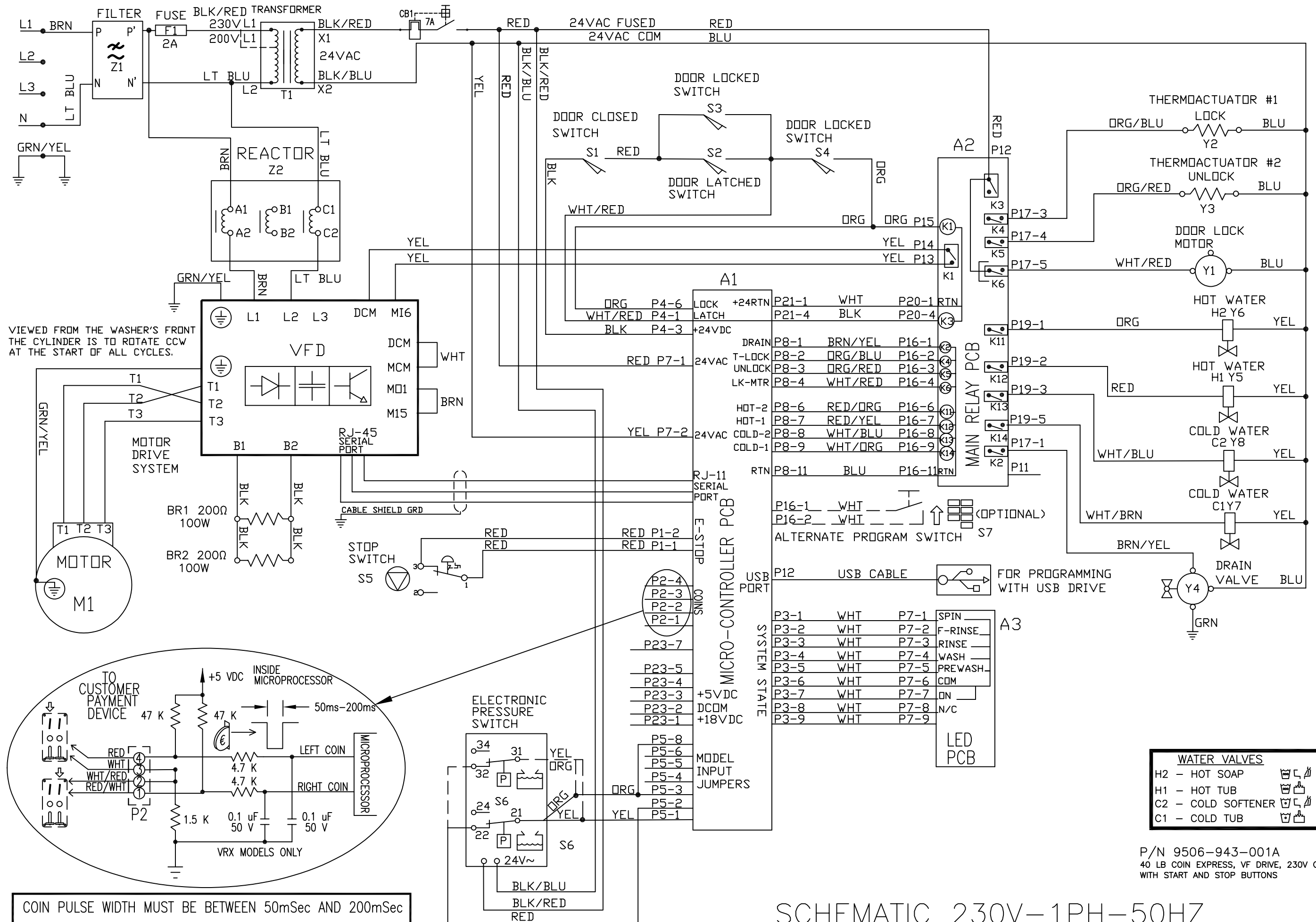

VIEWS FROM THE WASHER'S FRONT THE CYLINDER IS TO ROTATE CCW AT THE START OF ALL CYCLES.

COIN PULSE WIDTH MUST BE BETWEEN 50mSec AND 200mSec

WATER VALVES		
H2 - HOT SOAP		
H1 - HOT TUB		
C2 - COLD SOFTENER		
C1 - COLD TUB		

P/N 9506-943-001A
40 LB COIN EXPRESS, VF DRIVE, 230V CE
WITH START AND STOP BUTTONS

SCHEMATIC 230V-1PH-50HZ

LOCATION: TOP FRONT

LOCATION: BOTTOM

LOCATION: BACK

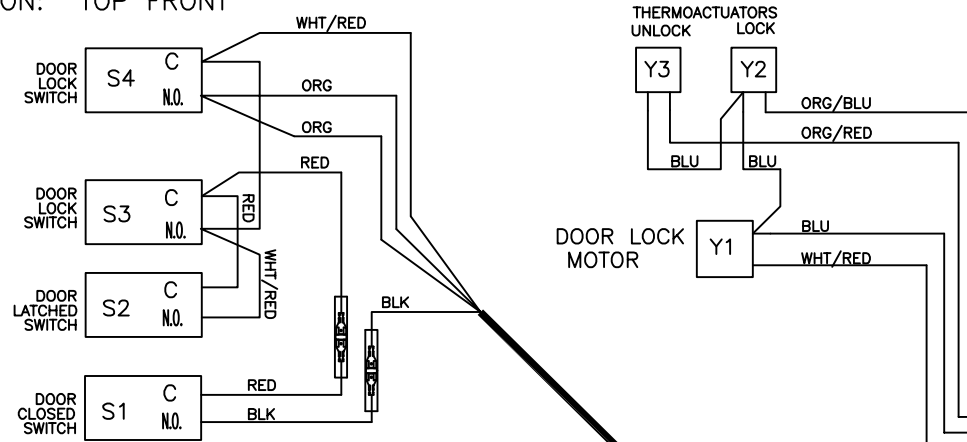

LOCATION: CONTROL TROUGH

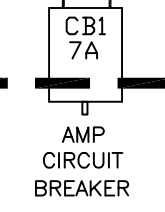
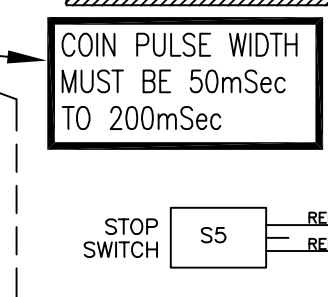
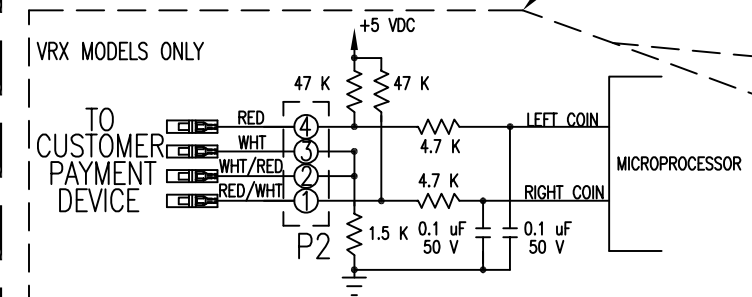
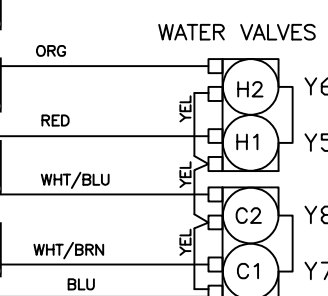
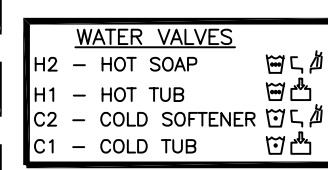
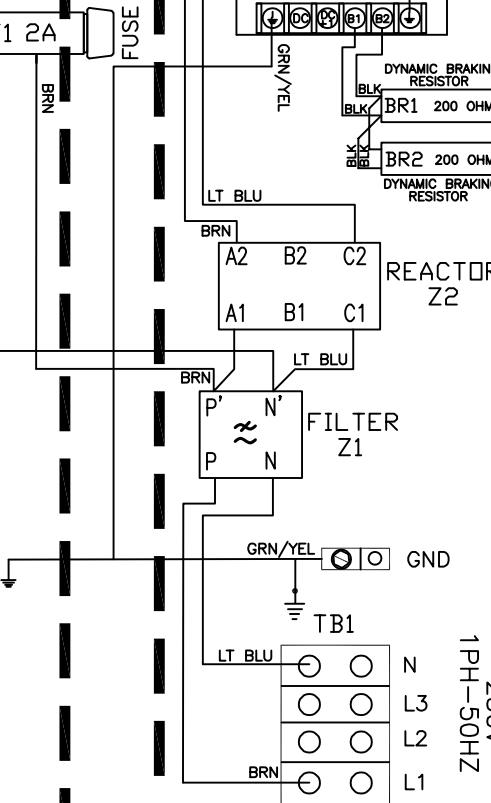
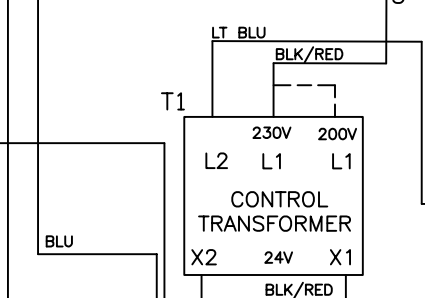
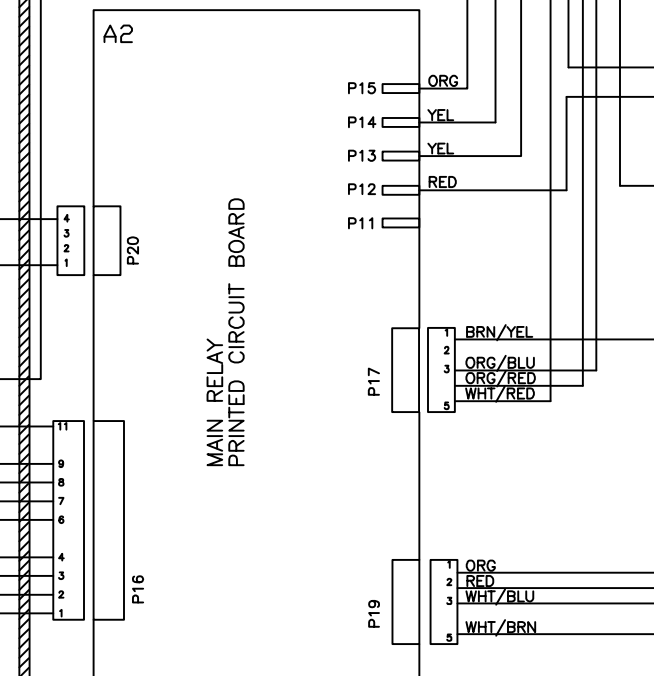
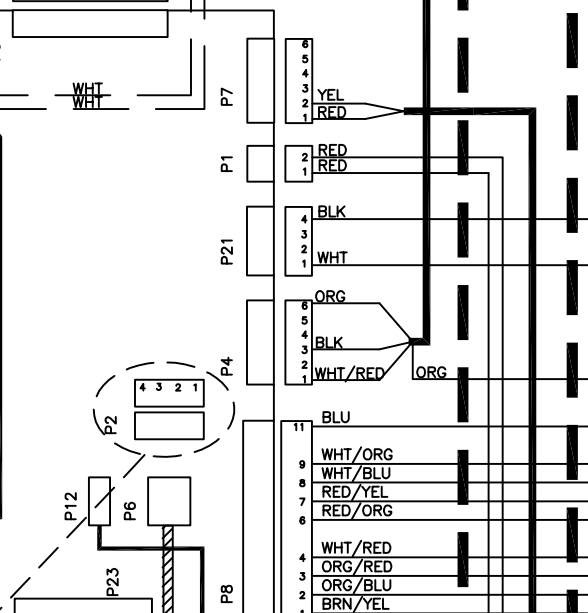
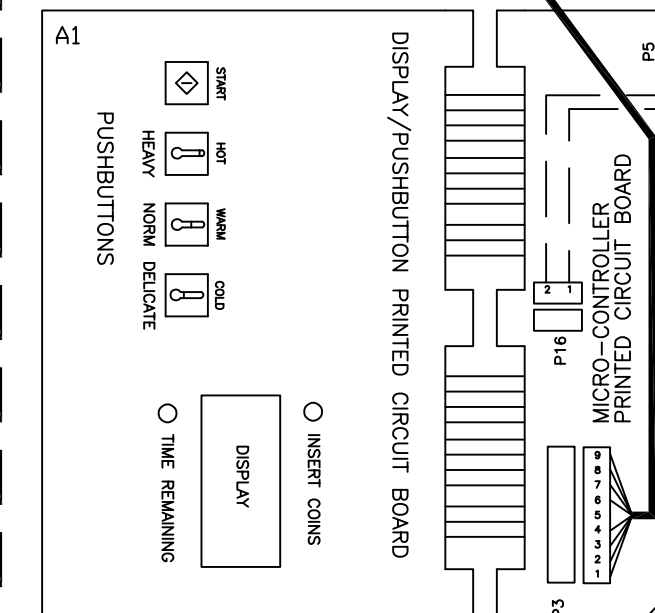
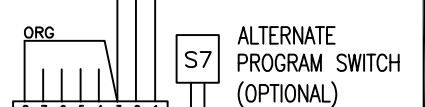
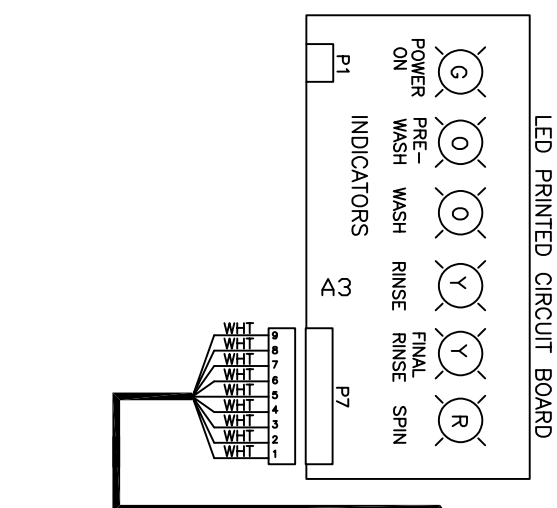
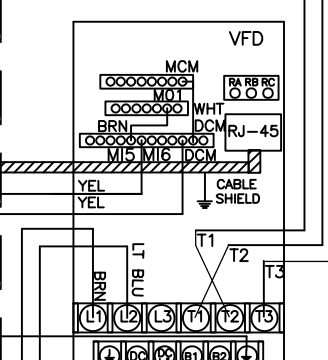
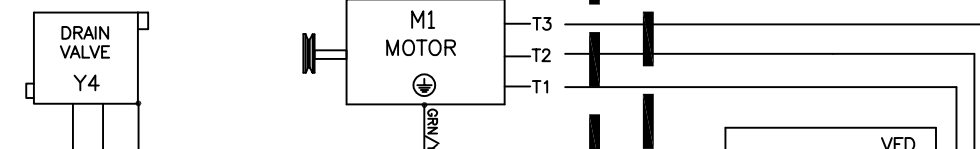
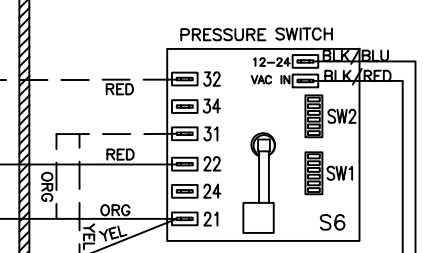

P/N 9506-943-001A
 40 LB COIN EXPRESS, VF DRIVE, 230V CE
 WITH START AND STOP BUTTONS

WIRING DIAGRAM 230V-1PH-50HZ

COLOR GUIDE			
COLOR	ENGLISH	ITALIANO	Ελληνικά
BRN	BROWN	MARRONE	ΚΑΦΕ
LT BLU	LIGHT BLUE	AZZURRO	ΑΝΟΙΧΤΟ ΜΠΛΕ
BLK	BLACK	NERO	ΜΑΥΡΟ
RED	RED	ROSSO	ΚΟΚΚΙΝΟ
BLU	BLUE	BLU	ΜΠΛΕ
GRN	GREEN	VERDE	ΠΡΑΣΙΝΟ
YEL	YELLOW	GIALLO	ΚΙΤΡΙΝΟ
ORG	ORANGE	ARANCIONE	ΠΟΡΤΟΚΑΛΙ
WHT	WHITE	BIANCO	ΛΕΥΚΟ

COMPONENT GUIDE			
COMPONENT	ENGLISH	ITALIANO	Ελληνικά
Z1	FILTER	FILTRO	ΦΙΛΤΡΟ
Z2	REACTOR	REATTORE	ΑΝΤΙΔΡΑΣΗ
Z3	TORRID (NOT USED)	TOROIDE	ΠΕΡΙΣΤΡΟΦΗΣ
Z4	FERRITE (NOT USED)	FERRITO	ΦΕΡΡΙΤΗΣ
VFD	INVERTER	INVERTER	ΜΕΤΑΣΧΗΜΑΤΙΣΤΗΣ
M1	MOTOR	MOTORE	Μοτέρ
F1	FUSE	FUSIBILE	Ασφάλεια
CB1	CIRCUIT BREAKER	INTERRUTTORE CIRCUITO	Ασφαλειοδιακόπτης
T1	CONTROL TRANSFORMER	TRASFORMATORE-COMANDI	ΜΕΤΑΣΧΗΜΑΤΙΣΤΗΣ-ΕΛΕΓΧΟΥ
TB1	MAIN SUPPLY TERMINAL BLOCK	MORSETTIERA-ALIMENTAZIONE PRINCIPALE	ΜΟΝΑΔΑ ΤΕΡΜΑΤΙΚΟΥ-ΚΕΝΤΡΙΚΗ ΠΑΡΟΧΗ
TB2	COMMON TERMINAL BLOCK	MORSETTIERA-COMUNE	ΜΟΝΑΔΑ ΤΕΡΜΑΤΙΚΟΥ-ΚΟΙΝΟ
BR1	BRAKING RESISTOR	RESISTENZA DI FRENATURA	ΑΝΤΙΣΤΑΣΗ ΠΕΔΗΣΗΣ
BR2	BRAKING RESISTOR	RESISTENZA DI FRENATURA	ΑΝΤΙΣΤΑΣΗ ΠΕΔΗΣΗΣ
S1	DOOR CLOSED SWITCH	INTERRUTTORE-CHIUSURA SPORTELLO	ΔΙΑΚΟΠΤΗΣ-ΚΛΕΙΣΙΜΟ ΠΟΡΤΑΣ
S2	DOOR LATCHED SWITCH	INTERRUTTORE-SERRATURA SPORTELLO	ΔΙΑΚΟΠΤΗΣ-ΑΣΦΑΛΙΣΗ ΠΟΡΤΑΣ
S3	DOOR LOCKED SWITCH	INTERRUTTORE-BLOCCO SPORTELLO	ΔΙΑΚΟΠΤΗΣ-ΚΛΕΙΔΩΜΑ ΠΟΡΤΑΣ
S4	DOOR LOCKED SWITCH	INTERRUTTORE-BLOCCO SPORTELLO	ΔΙΑΚΟΠΤΗΣ-ΚΛΕΙΔΩΜΑ ΠΟΡΤΑΣ
S5	STOP SWITCH	INTERRUTTORE-ARRESTO	ΔΙΑΚΟΠΤΗΣ-ΤΕΡΜΑΤΙΣΜΟΣ
S6	ELECTRONIC PRESSURE SWITCH	INTERRUTTORE-	ΔΙΑΚΟΠΤΗΣ-
S7	ALTERNATE PROGRAM SWITCH	INTERRUTTORE-PROGRAMMAZIONE	ΔΙΑΚΟΠΤΗΣ-ΠΡΟΓΡΑΜΜΑΤΙΣΜΟΣ
A1	CONTROL PCB	GRUPPO-COMANDO PRINCIPALE	ΜΟΝΑΔΑ-ΚΥΡΙΟΣ ΠΙΝΑΚΑΣ ΕΛΕΓΧΟΥ
A2	RELAY PCB	GRUPPO-SCHEDA RELE'	ΜΟΝΑΔΑ - ΠΙΝΑΚΑΣ ΡΕΛΕ
A3	LED PCB	GRUPPO-DISPLAY	ΜΟΝΑΔΑ - ΕΝΔΕΙΞΕΙΣ
Y1	DOOR LOCK MOTOR	MOTORE-BLOCCO SPORTELLO	ΜΟΤΕΡ - ΚΛΕΙΔΩΜΑ ΠΟΡΤΑΣ
Y2	LOCK THERMOACTUATOR	TERMOATTUATORE-BLOCCO	ΘΕΡΜΟΕΝΕΡΓΟΠΟΙΗΤΗΣ - ΚΛΕΙΔΩΜΑ
Y3	UNLOCK THERMOACTUATOR	TERMOATTUATORE-SBLOCCO	ΘΕΡΜΟΕΝΕΡΓΟΠΟΙΗΤΗΣ - ΞΕΚΛΕΙΔΩΜΑ
Y4	DRAIN VALVE	VALVOLA-SCARICO	ΒΑΛΒΙΔΑ - ΑΠΟΣΤΡΑΓΓΙΣΗ
Y5	HOT WATER FILL VALVE	VALVOLA-RIEMPIMENTO ACQUA CALDA	ΒΑΛΒΙΔΑ - ΠΛΗΡΩΣΗ ΖΕΣΤΟΥ ΝΕΡΟΥ
Y6	HOT WATER FLUSH VALVE	VALVOLA-SCARICO ACQUA CALDA	ΒΑΛΒΙΔΑ - ΕΚΠΛΥΣΗ ΖΕΣΤΟΥ ΝΕΡΟΥ
Y7	COLD WATER FILL VALVE	VALVOLA-RIEMPIMENTO ACQUA FREDDA	ΒΑΛΒΙΔΑ - ΠΛΗΡΩΣΗ ΚΡΥΟΥ ΝΕΡΟΥ
Y8	COLD WATER FLUSH VALVE	VALVOLA-SCARICO ACQUA FREDDA	ΒΑΛΒΙΔΑ - ΕΚΠΛΥΣΗ ΚΡΥΟΥ ΝΕΡΟΥ