

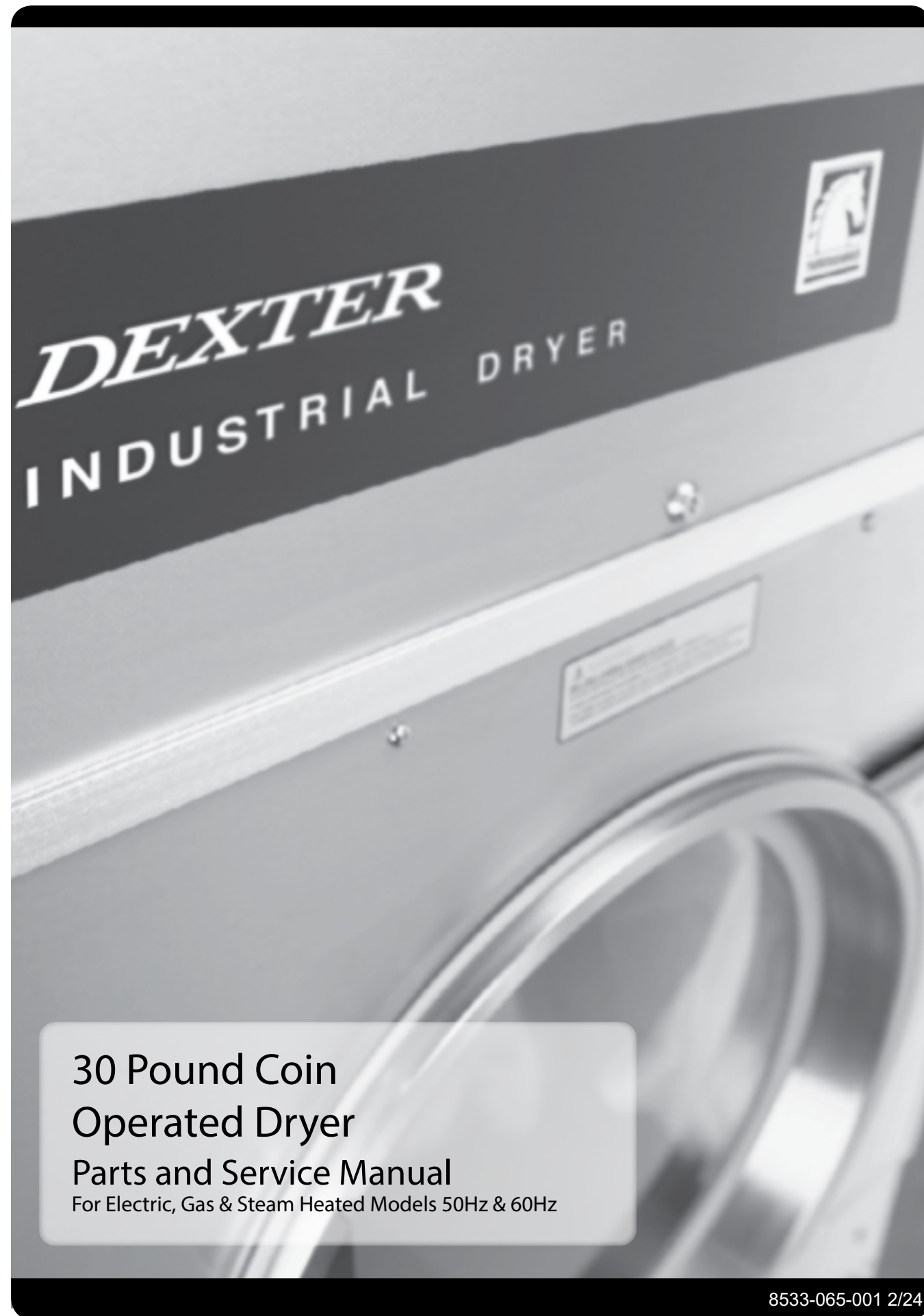

***DEXTER.***  
***LAUNDRY***

**USE THE BLUE TABS LOCATED ON THE  
RIGHT AND LEFT SIDES OF THE FOLLOWING  
DOCUMENT TO ADVANCE TO EACH SECTION.**



## 30 Pound Coin Operated Dryer

### Parts and Service Manual

For Electric, Gas & Steam Heated Models 50Hz & 60Hz

8533-065-001 2/24

## Dexter Safety Guidelines

### ! WARNING

The dryer must not be stored or installed where it will be exposed to water and/or weather.

For your safety the information in this manual must be followed to minimize the risk of fire or explosion or to prevent property damage, personal injury or death. Do not store or use gasoline or other flammable vapors and liquids in the vicinity of this or any other appliance.

### WHAT TO DO IF YOU SMELL GAS

- Do not try to light any appliance.
- Do not touch any electrical switch: do not use any telephone in your building.
- Clear the room, building or area of all occupants.
- Immediately call your gas supplier from a neighbor's telephone.
- Follow the gas supplier's instructions.
- If you cannot reach your gas supplier, call the fire department. Installation and service must be performed by a qualified installer, service agency or the gas supplier.

***To activate your warranty, be sure to return your red warranty form to the factory. Please have serial number and model ready when calling for assistance.***

You, the purchaser, must post in a prominent location instructions to be followed in the event the user smells gas. Consult your local gas supplier for procedure to be followed if the odor of gas is present.

Post the following "For Your Safety" caution in a prominent location:

### FOR YOUR SAFETY

Do not store or use gasoline or other flammable vapors or liquids in the vicinity of this or any other appliance.

THIS MACHINE  
IS FOR DRYING  
ONLY FABRICS  
CLEANED IN  
WATER.

To avoid possibility of fire, including spontaneous combustion, do not dry oiled floor mops, items containing foam rubber or similarly textured rubberlike materials or any material on which you have used a cleaning solvent or which contains flammable liquids or solids (such as gasoline, kerosene, waxes, etc.)

Specifications for below models  
are outlined in this book:

<b>DCTD30KC__10</b>	<b>Gas Heated</b>	<b>120/60/1</b>
<b>DCTD30KC__21CR</b>	<b>Gas Heated</b>	<b>230/50/1</b>
<b>DCTD30KC__16FE</b>	<b>Electric Heated - 30 KW</b>	<b>208/60/3</b>
<b>DCTD30KC__59</b>	<b>Gas Heated</b>	<b>230/50/1</b>
<b>DCTD30KC__66FW</b>	<b>Electric Heated - 15 KW</b>	<b>415/50/3</b>
<b>DLC30Q</b>	<b>Gas Heated</b>	

Mounting Dimensions

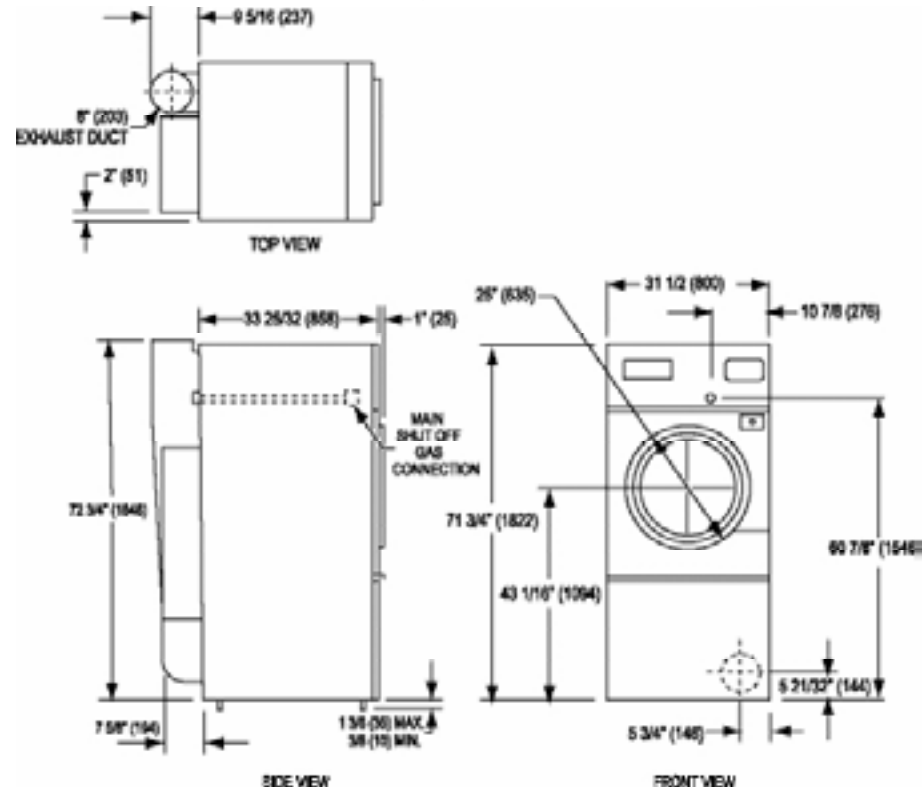

Section 1:  
Specifications

Model DTCD30

w/ Microprocessor Control Gas Heat Source

<b>Dry Weight Capacity (lbs)</b>	30 lbs
<b>Dimensions</b>	
Basket Depth	29 1/2"
Basket Diameter	30"
Basket Volume	12.07 cu ft.
Door Opening	22 11/16"
Overall Height (with legs)	73 1/8" minimum, 74 1/8" maximum
Cabinet Width	31 1/2"
Overall Depth	43 1/4"
Door Height (floor to center of door)	43 1/16"
Necessary Service Clearance Behind Machine	18"

<b>Temperature (degrees)</b>	
Regular/Hot	150 - 190 F
(factory setting)	175 F
Permanent Press/Medium	120 - 170 F
(factory setting)	150 F
Delicate/Warm	110 - 150 F
(factory setting)	125 F

<b>Electrical</b>	
Motor HP	1/2 HP
Electrical Running Amps	9.6
Circuit Breaker (amps)	15
Built-in Motor Protection Circuit	Yes
Phase	Single
Voltage (60 Hz)	120 V
Circuit Protection (60 Hz)	15 AMP
Service	2 wire + ground
Wire Size	#12

<b>Cylinder Rotation</b>	
Direction	counter clockwise
Speed (RPM)	47

<b>Gas</b>	
Natural (supply line)	5" - 8" WC
Natural (burner manifold)	3 1/2" WC
L.P. (supply line)	11" - 14" WC
L.P. (burner manifold)	11" WC
Inlet Line Size	1/2" NPT
BTU Input	90,000

<b>Venting</b>	
Air Flow (cfm)	830
Size	8"
Maximum Length with 2 elbows	20 ft.
Maximum Length with 4 elbows	16 ft.
Make-up Air - Each Dryer (minimum)	1 sq. ft.

<b>Shipping Weight (lbs)</b>	<b>486</b>
<b>Net Weight (lbs)</b>	<b>439</b>

# Section 2: Installation & Operation

## Section 2: Uncrating, Installation & Operation

Remove cardboard and innerpack. Complete the uncrating as described in the procedure listed on the instruction sheet taped to the loading door glass.

### Field Assembly

For secure packaging, the dryer is shipped with the tee, one part of the heat reclaimer, inside the lower service door.

### Installation

1. Remove 4 metal screws from the bag in coin box. Go to the rear of the dryer and remove the tape holding the top of the vertical 8" pipe.
2. Install the tee into both the vertical pipe and the horizontal boot. Using the four pilot holes provided, drill 4 matching 9/64 inch (3.6) diameter mounting holes; 2 holes through the boot into the tee outlet, and 2 holes through the tee inlet into the 8 inch vertical pipe. Install the 4 screws provided to secure the tee to the pipe and boot.
3. Install your exhaust system to the tee. Tape all joints with 2" duct tape.

### Alternate Installation

If it is desired to have the dryer exhaust at a low level, the installation can be altered as shown in the following illustration:

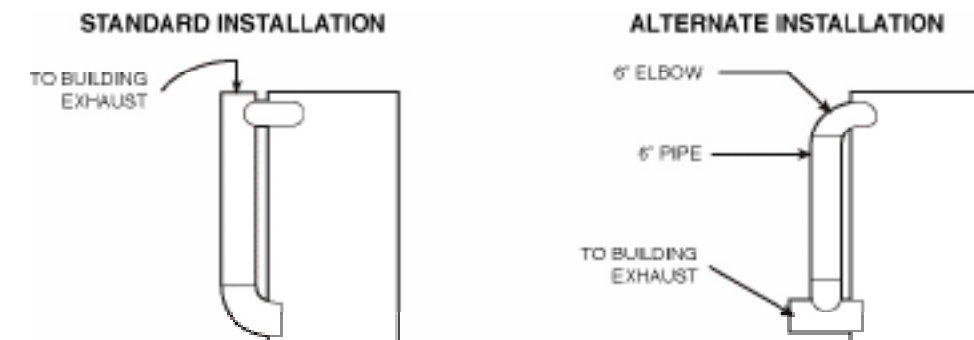

The installer should acquire a 6" dia. 90° elbow and 6" dia. straight pipe for the two areas shown in the alternate installation.

The exhaust tee may be cut off on the long end to give an over all length of 14" (356). This allows you to come vertically to the 6" elbow above. (The necessary pipe for the standard installation is included as shown.)

### Dryer Installation

1. **CODE CONFORMITY.** All commercial dryer installations must conform with local codes or, in the absence of local codes, with the latest edition of the National Fuel Gas Code ANSI 2223. 1. Canadian installations must comply with current Standard CAN/CGA-B149 (.1 or .2) Installation Code for Gas Burning Appliances or Equipment, and local codes if applicable. The appliance, when installed, must be electrically grounded in accordance with the latest edition of the National Electric Code, ANSI/NFPA70, or, when installed in Canada, with Standard CSA C22.1 Canadian Electrical Code Part 1.
2. **INSTALLATION CLEARANCES:** This unit may be installed at the following alcove clearance. (millimeters)

- I. Left Side 0"
- II. Right Side 1" (25)
- III. Back 18" (457) (Certified for 1" (25) clearance; however, 18" (457) clearance is necessary behind the belt guard to allow servicing and maintenance.)
- IV 48" (1220) (to allow use of dryer)
- V Top Refer to figure labelled "Vertical Clearance Dimensions"
  - AB. Certification allows 0" clearance at the top 1" (25) back from the front. However, a 1/4" (6) clearance is required to allow opening the upper service door.
  - CD. A 4" (102) clearance is required at the top between 1" (25) and 4" (102) from front.
  - E. A 10" (254) clearance is required from top at all other points.
- VI Floor This unit may be installed upon a combustible floor.

\*Units may be installed in direct contact with an adjacent dryer, providing allowance is made for opening upper and lower service doors.

Do not obstruct the flow of combustion and ventilation air.

Maintain minimum of 1" (25) clearance between duct and combustible material.

Refer to installation label attached to the inside surface of the upper door of the dryer for other installation information.

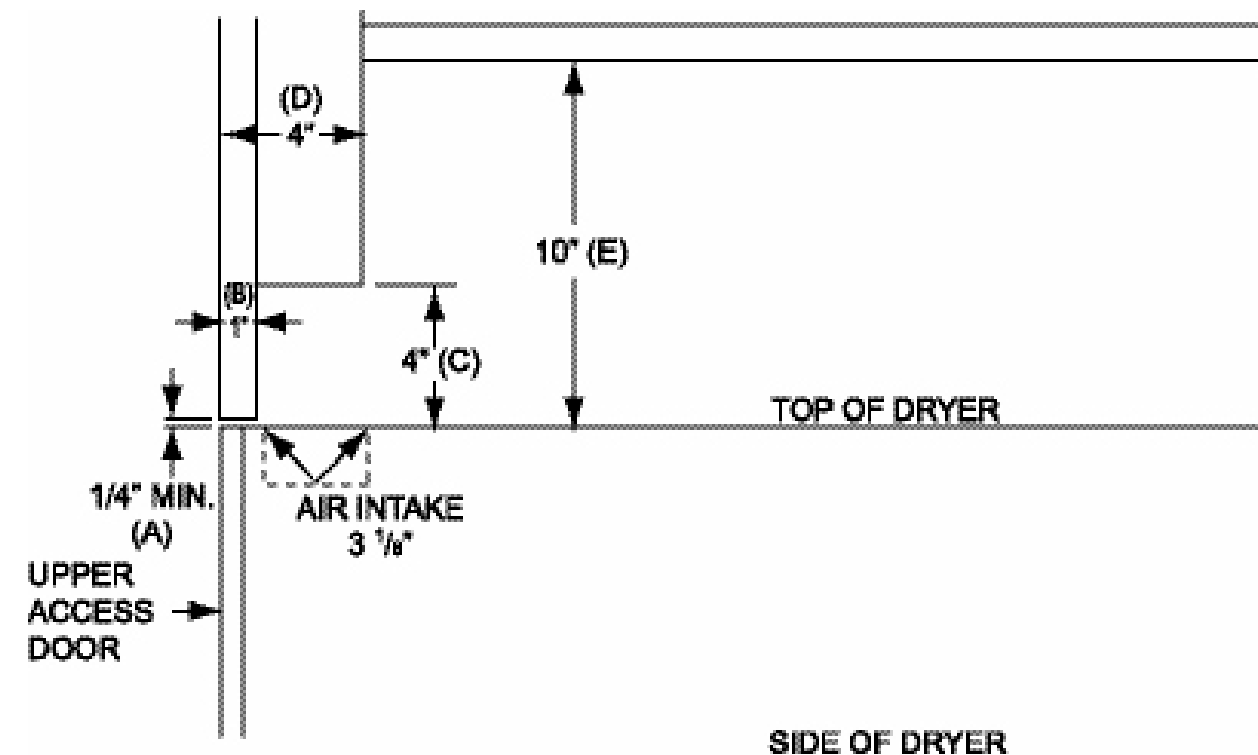

**Vertical Clearance Dimensions**

3. MAKE-UP AIR. Adequate make-up air (830 CFM) must be supplied to replace air exhausted by dryers on all types of installations. Provide a minimum of one square foot make-up air opening to the outside for each dryer. This is a net requirement of effective area. Screens, grills or louvers which will restrict the flow of air must be considered. Consult the supplier to determine the free area equivalent for the grill being used.

The source of make-up air should be located sufficiently away from the dryers to allow an even airflow to the air intakes of all dryers. Multiple openings should be provided.

**NOTE:** The following considerations must be observed for gas dryer installations where dry cleaners are installed. The sources of all make-up air and room ventilation air movement to all dryers must be located away from any dry cleaners. This is necessary so that solvent vapors will not be drawn into the dryer inlet ducts. Dry cleaner solvent vapors will decompose in contact with an open flame such as the gas flame present in clothes dryers. The decomposition products are highly corrosive and will cause damage to the dryer(s), ducts and clothes loads.

4. ELECTRICAL REQUIREMENTS. The electrical power requirements necessary to operate the unit satisfactorily are listed on the serial plate located on the back panel of each dryer. The electrical connection should be made to the pig tail leads in the outlet box (or terminal board, if supplied) on the rear of the unit, using a wire size adequate to handle the amperage and voltage listed on the serial plate, but never smaller than NO.12 AWG wire. It is absolutely necessary that the dryer be grounded to a known ground.

Individual circuit breakers for each unit are recommended. The wiring diagram is located on the belt guard on the back of the machine.

5. GAS REQUIREMENTS. The complete gas requirements necessary to operate the dryer satisfactorily are listed on the serial plate located on the back panel of the dryer.

- The inlet gas connection to the unit is 1/2 inch pipe thread. A joint compound resistant to the action of liquefied petroleum gases should be employed in making pipe connections.
- An 1/8 inch NPT plugged tapping, accessible for test gage connection, must be installed immediately upstream of the gas supply connection to the dryer.
- A drip tee should be provided in the gas piping entering the unit to catch dirt and other foreign articles.
- All pipe connections should be checked for leakage with soap solution. Never check with an open flame. For altitudes above 2,000 feet (610m) it is necessary to derate the BTU input. Contact your local distributor for instructions.
- L.P. gas conversion kits are available for this dryer. Contact your local distributor.

**CAUTION:** The dryer and its individual shutoff valve must be disconnected from the gas supply piping system during any pressure testing of that system at test pressures in excess of 1/2 psig. The dryer must be isolated from the gas supply piping system by closing its individual manual shutoff valve during any pressure testing of the gas supply piping system at test pressures equal to or less than 1/2 psig.

6. EXHAUST INSTALLATION. (Refer to Figure 2 at the end of section 6.) EXhausting of the dryer(s) should be planned and constructed so that no air restrictions occur. Any restriction due to pipe size or type of installation can cause slow drying time, excessive heat, and lint in the room. From an operational standpoint, incorrect or inadequate exhausting can cause a cycling of the high limit thermostat which shuts off the main burners and results in inefficient drying.

Individual exhausting of the dryers is recommended. All heat, moisture, and lint should be exhausted outside by attaching a pipe of the proper diameter to the dryer adapter collar and extending it out through an outside wall. This pipe must be very smooth on the inside, as rough surfaces tend to collect lint which will eventually clog the duct and prevent the dryer from exhausting properly. All elbows must be smooth on the inside. All joints must be made so the exhaust end of one pipe is inside the next one downstream. The addition of an exhaust pipe tends to reduce the amount of air the blower can exhaust. This does not affect the dryer operation if held within practical limits. For the most efficient operation, it is recommended that no more than 20 feet (8m) of straight 8" diameter pipe be used with two right angle elbows. When more

than two elbows are used, two feet of straight pipe should be removed for each additional elbow. No more than four right angle elbows should be used to exhaust a dryer.

Maintain a minimum of 1" (25) clearance between duct and combustible material.

If the exhaust pipe passes through a wall, a metal sleeve of slightly larger diameter should be set in the wall and the exhaust pipe passed through this sleeve. This practice is required by some local codes and is recommended in all cases to protect the wall. This type of installation should have a means provided to prevent rain and high winds from entering the exhaust when the dryer is not in use. A hood with a hinged damper can be used for this purpose. Another method would be to point the outlet end of the pipe downward to prevent entrance of wind and rain. In either case, the outlet should be kept clear, by at least 24" (810), of any objects which would cause an air restriction.

Never install a protective screen over the exhaust outlet.

When exhausting a dryer straight up through a roof, the overall length of the duct has the same limits as exhausting through a wall. A rain cap must be placed on top of the exhaust and must be of such a type as to be free from clogging. The type using a cone shaped "roof" over the pipe is suitable for this application.

Exhausting the dryer into a chimney or under a building is not permitted. In either case there is a danger of lint build-up which can be highly combustible.

Installation of several dryers where a main discharge duct is necessary, will need the following considerations for installation (see Fig. 2). Individual 8" ducts from the dryers into the main discharge duct should be at a 45 degree angle in the direction of discharge air flow.

**NOTE:** Never install the individual 8" ducts at a right angle into the main discharge duct. The individual ducts from the dryers can enter at the sides or bottom of the main discharge duct. Figure 2 indicates the various round main duct diameter to use with the individual dryer ducts. The main duct can be rectangular or round, provided adequate airflow is maintained. For each individual dryer, the total exhausting (main discharge duct plus duct outlet from the dryer) should not exceed the equivalent of 20 feet (8m) and two elbows. The diameter of the main discharge duct at the last dryer must be maintained to exhaust end.

**NOTE:** A small diameter duct will restrict air flow; a large diameter duct will reduce air velocity -- both contributing to lint buildup. An inspection door should be provided for periodic clean-out of the main duct.

**NOTE:** STATIC BACK PRESSURE should be a maximum of 0.3 in. w.c (7.6 mm w.c) at the rear exhaust outlet of the dryer. If multiple dryers are connected to the common duct, ensure the back draft damper is installed properly.

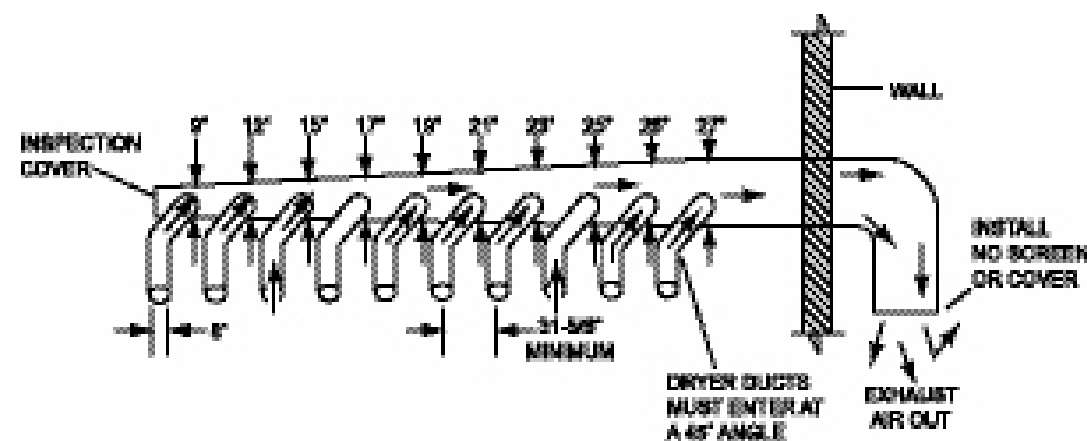

7. DRYER IGNITION (SOLID STATE IGNITION). The solid state ignition system lights the main burner gas by spark. The gas is ignited and burns only when the gas-valve relay (in the electronic controller) calls for heat. The procedure for first-time starting of a dryer is as follows:

A. First, review and comply with the "Warnings About Use and Operation" found on the inside front cover of this manual. Be sure the electrical power supply is connected correctly. The white wire is to be connected to the white wire (common) in the junction box and the black wire to the black wire (power leg). The dryer MUST be properly grounded.

B. Make sure all gas supply lines are purged of air. Close the main gas shut-off valve and wait for five minutes before turning the valve back on.

C. Turn on the main electrical power switch. The dryer may be started by following the "Operating Instructions" found later in this manual.

D. Natural gas and liquefied petroleum gas fired dryers both operate in the same manner. When the gas-valve relay contacts are closed (indicating a demand for heat), the solid state ignition control will automatically supply energy to the redundant gas valve. Spark will continue until a flame is detected by the sensing probe, but not longer than 10 seconds. If the gas fails to ignite within 10 seconds, the gas valve closes and the system will "lock out". No further attempts at ignition will be performed automatically. It is then necessary to interrupt electrical power to the ignition system before making another attempt at igniting the burners. This can be done by opening the dryer door and allowing the dryer to come to a stop for 15 seconds, then closing the door and pushing the "Start" button. The dryer will then repeat the ignition trial cycle.

8. MAIN BURNER ADJUSTMENT. The primary air shutter of each main burner must be properly adjusted for the correct air-gas ratio. Loosen the shutter locking screws. Adjust the shutter by closing it sufficiently to give a blue flame with a yellow tip. Next open the shutter until the yellow tips are at a minimum. After adjustment, securely lock each shutter in position by tightening the shutter locking screws.

## Dryer Shutdown

To render the dryer inoperative, turn off the main gas shut-off valve and disconnect electrical power to the dryer.

## Operating Instructions

1. Deposit coins to satisfy vend price display of idle dryer. Each deposit decreases vend price until display changes to show time purchased. WARM light illuminates.

2. Select drying cycle. Other cycle selections may be made now or later by pressing the appropriate key (button).

3. Close the loading door. Press [START] and the dryer will start. "Seconds" goes to [00]. "Minutes" is rounded up and will count down each minute. The colon flashes on and off indicating the timer is counting down.

4. Clothes should be removed promptly after the cycle is completed to prevent excessive wrinkling.

Once started, the "timer" cannot be stopped. However, extra coins will be acknowledged by adding time to the display. The dryer may be stopped by opening the loading door which interrupts the drive motor and gas burners. Close the loading door and push [-] to restart the dryer.

Cool-down time (owner programmable) is always part of the cycle time and is purchased by the customer. For example, if cool-down time is 2 minutes, the last 2 minutes of the cycle will have no heat.

## Description Of Controls

- Credit for coins deposited, dryer time and temperature are controlled by an electronic controller.
- The large digital display shows vend price of an idle dryer, time purchased after coins are deposited, temperature and program information.
- The three red indicator lights show the drying temperature selected. This selection may be made anytime.
- The drying temperature will be displayed when the start switch and the switch for the selected temperature are pressed at the same time.
- All programmed data is protected from power interruption of any length and the customer's individual cycle is protected for up to 3 seconds. This is done without batteries.
- The 3 temperature buttons and the start button become programming switches when the controller is in the program mode as described on page 10.

## Programming:

All operating parameters (vend price, temperatures, cool-down times, etc.) are adjustable. In addition, several displays of information are available from the controller (Money audits, hours run, dryer temperature).

The dryer is ready to run, from the factory, with the following pre-programmed data:

Temperature, HOT:	175 (degrees F) / 78 (degrees C)
Temperature, MEDIUM:	150 (degrees F) / 63 (degrees C)
Temperature, WARM:	125 (degrees F) / 48 (degrees C)
Vend Price:	25 (cents)
Time for Left Coin:	3:20 - 3 minutes, 20 seconds for a dime (doesn't apply to single-coin models)
Time for Right Coin:	10:00 (10 minutes for a quarter)
Time of Free Vend:	10:00 ("Free Dry" cycle is 10 minutes)
Cool-down Time, HOT:	2:00 (Cool-down time in HOT is 2 minutes)
Cool-down Time, MEDIUM:	2:00 (Same as above, except MEDIUM)
Cool-down Time, WARM:	2:00 (Same as above, except WARM)
Temperature Scale:	F or C degrees

All of the above data can be easily changed by the owner. The changes are made by the 4 keys or buttons on the front of the control panel.

## Changing Program Data

Put dryer in PROGRAM mode as instructed on page 9. The dryer remains in the PROGRAM mode until one of these actions occur:

- The switch is actuated again.
- The fifteenth step is completed and the START switch is pushed following the fifteenth step.
- Programming is stopped for about a minute.
- The loading door is closed.

Observe the displayed value in each step. If no change is required, press START to advance to the next program step. If a change is required the values are made larger by the HOT button, smaller by the PERM-PRESS button. The hour meter and money audit can be reset to zero if WARM is pressed. Note that after any reset or program change it is necessary to advance to the next step by pressing START to enter the revision. OTHERWISE THE VALUE WILL REMAIN AS IT WAS BEFORE THE ALTERATION.

## Single Pocket Dryer

### Computer Dryer

## Description of Electronic Control

The single electronic control unit controls the coin count, dry time, temperature and information display. The digital display shows vend price when waiting for coins to be inserted and time purchased after coins have been deposited. When the tumbler is in use, the display shows the number of minutes remaining to be used. The three temperature selection buttons have indicator lights to indicate which temperature selection has been made. At the end of the cycle, the digital display flashes until the operator opens the door to remove the load. Temperature readout is available by pressing the temperature selection button that is in use along with the start button.

## Electronic Control Features Available ( shown in picture below)

1. **Anti-Wrinkle**  
After a dryer has completed its dry time, the dryer will tumble intermittently without heat, until the door is opened. This is to reduce wrinkling of the clothes. This feature may be selected by removing a jumper from the electronic control.
2. **Last Temperature Used**  
After a dryer has completed its dry time, the temperature that was being used will be selected for the next use, unless the new user selects a different one. This feature may be selected by removing a jumper from the electronic control.
3. **Battery Back-up**  
All programmed and dry time remaining data are protected from power interruption by battery back-up.

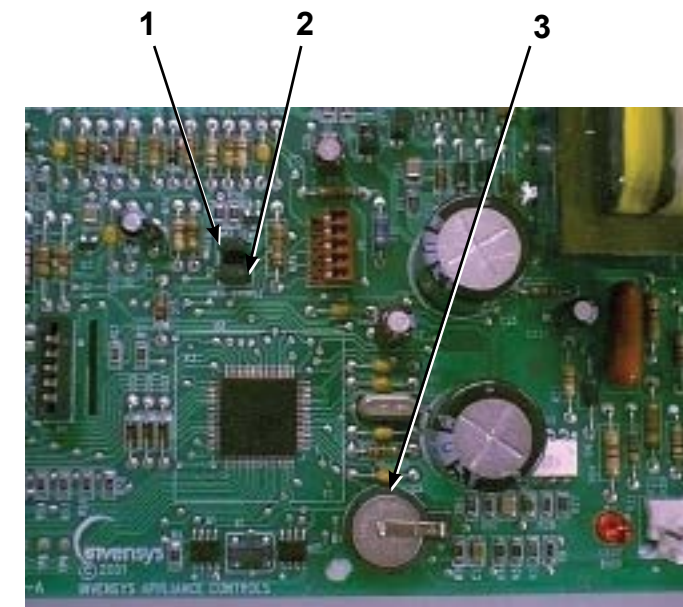

# Programming Computer Control

## ENTERING THE PROGRAM MODE

1. Unlock and open the upper service door.
2. Open the loading door.
3. Remove the metal plug found just to the left of the WARM cycle light.
4. Push the Program Button that is now accessible through a hole in the control mounting plate.
5. The control will switch to the Program mode.

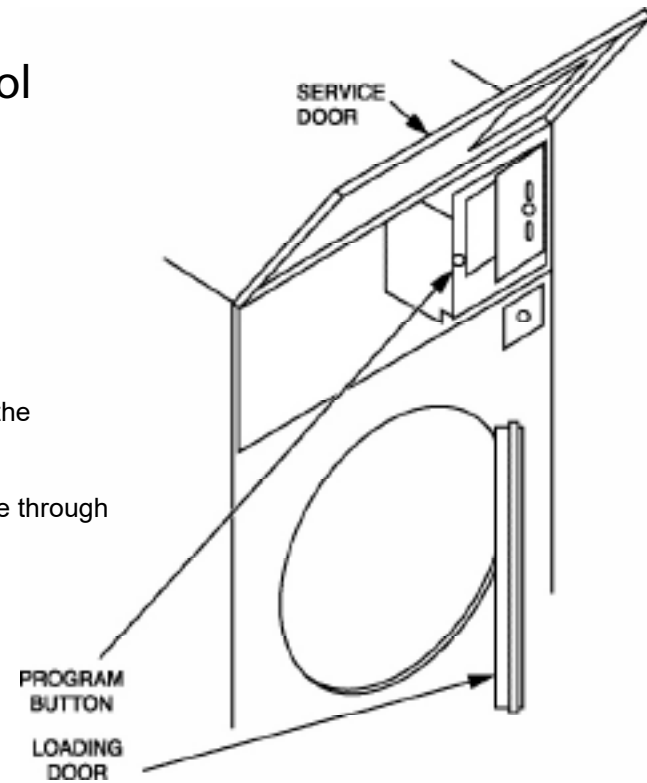

## PROGRAMMING

1. The annunciator lights in the display and temperature lights identify each programming step. (Shown on following page.)
2. The START button advances the controller to the next programming step and stores any changes to the program in memory.
3. The HOT and PERM PRESS buttons increase and decrease the values in the display.
4. The WARM button zeroes the hour meter and coin audit in program steps 1 and 2. This button also restores the original factory settings for the step being displayed in program steps 3 through 15.

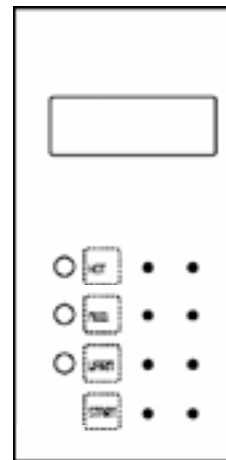

ANNUNCIATOR LIGHTS WHICH HELP IDENTIFY PROGRAMMING STEPS

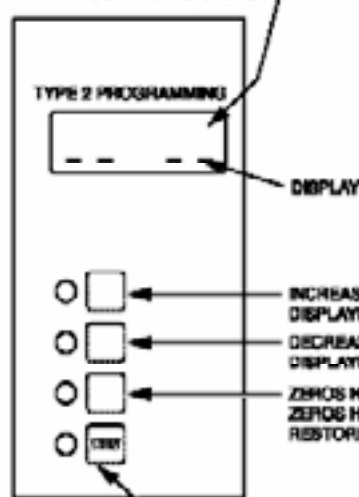

**IMPORTANT:** Please remember to push [START] to actually enter (store in memory) new data. If you merely change the display, memory hasn't yet been changed. Always push [START] after any program change before exiting the program mode.

START: Stores the displayed value in memory, and advances the controller to the next programming step.

## ORDER OF PROGRAMMING STEPS

CYCLE LIGHTS	DISPLAY	PROGRAMMING STEP	OPTIONS/RANGE OF LIMITS	FACTORY SETTINGS
		Hour meter	May be reset / 0 to 9999hr.	0
● H ● M ● W	--	Left Coin Audit	May be reset / 0 to 9999 coins	0
● H ● M ● W	--	Right Coin Audit	May be reset / 0 to 9999 coins	0
● H	--	Temperature, Hot	150 to 190 degrees F (5 degree increments)	175
● M	--	Temperature, Perm Press	120 to 170 degrees F (5 degree increments)	150
● W	--	Temperature, Warm	110 to 150 degrees F (5 degree increments)	125
	--	Left Coin Value	0 to 100 cents (5 cent increments)	\$0.10
	--	Right Coin Value	0 to 100 cents (5 cent increments)	\$0.25
	--	Vend Price	0 to 100 (5 cent increments)	\$0.25
	--	Time for Left Coin	0 to 99:55 min. (5 sec. increments)	10:00
	--	Time for Right Coin	0 to 99:55 min. (5 sec. increments)	10:00
	--	Time of Free Vend	0 to 99:55 min. (5 sec. increments)	10:00
● H	--	Cool-down Time, Hot	0 to 10 minutes (5 sec. increments)	2:00
● M	--	Cool-down Time, Medium	0 to 10 minutes (5 sec. increments)	2:00
● W	--	Cool-down Time, Warm	0 to 10 minutes (5 sec. increments)	2:00
	F	Temperature Scale	Celsius or Fahrenheit	C or F

Hour meter May be reset / 0 to 9999hr. 0  
H  
M Left Coin Audit May be reset / 0 to 9999 coins 0  
W  
H Right Coin Audit May be reset / 0 to 9999 coins 0  
M  
W  
H Temperature, Hot 150 to 190 degrees F 175  
(5 degrees increments)  
M Temperature, Perm Press 120 to 170 degrees F 150  
(5 degree increments)  
W Temperature, Warm 110 to 150 degrees F 125  
(5 degree increments)  
Left Coin Value 0 to 100 cents \$.10  
(5 cent increments)  
Right Coin Value 0 to 100 cents \$.25  
(5 cent increments)  
Vend Price 0 to 100 \$.25  
(5 cent increments)  
Time for Left Coin 0 to 99:55 min. 10:00  
(5 sec. increments)  
Time for Right Coin 0 to 99:55 min. 10:00  
(5 sec. increments)  
Time of Free Vend 0 to 99:55 min. 10:00  
(5 sec. increments)  
H Cool-down Time, Hot 0 to 10 minutes 2:00  
(5 sec. increments)  
M Cool-down Time, Medium 0 to 10 minutes 2:00  
(5 sec. increments)  
W Cool-down Time, Warm 0 to 10 minutes 2:00  
(5 sec. increments)  
f Temperature Scale Celsius or Fahrenheit C or F

## TRANSIENT VOLTAGE SURGE SUPPRESSORS

Like most electrical equipment your new machine can be damaged or have its life shortened by voltage surges due to lightning strikes which are not covered by factory warranty. Local power distribution problems also can be detrimental to the life of electrical components. We recommend the installation of transient voltage surge suppressors for your new equipment. These devices may be placed at the power supply panel for the complete installation and don't require an individual device for each machine.

These surge protectors help to protect equipment from large spikes and also from small ongoing spikes in the power that occur on a day to day basis. These smaller surges can shorten overall life of electrical components of all types and cause their failure at a later date. Although they can't protect against all events, these protective devices have a good reputation for significantly lengthening the useful life of electronic components.

Electronic Components are helped to have a longer useful life when they are supplied with the clean stable electrical power they like.

We are including the following names and links to a few suppliers of these devices for those who don't currently have a source.

MANUFACTURER	LINK
MCG Surge Protection	<a href="http://mcgsurge.com">mcgsurge.com</a>
Eaton Corporation	<a href="http://eaton.com/us/en-us">eaton.com/us/en-us</a>
Schneider Electric	<a href="http://se.com/us/en">se.com/us/en</a>
Asco Power Technologies	<a href="http://ascopower.com/us/en">ascopower.com/us/en</a>
Emerson Electric Co.	<a href="http://emerson.com/en-us">emerson.com/en-us</a>



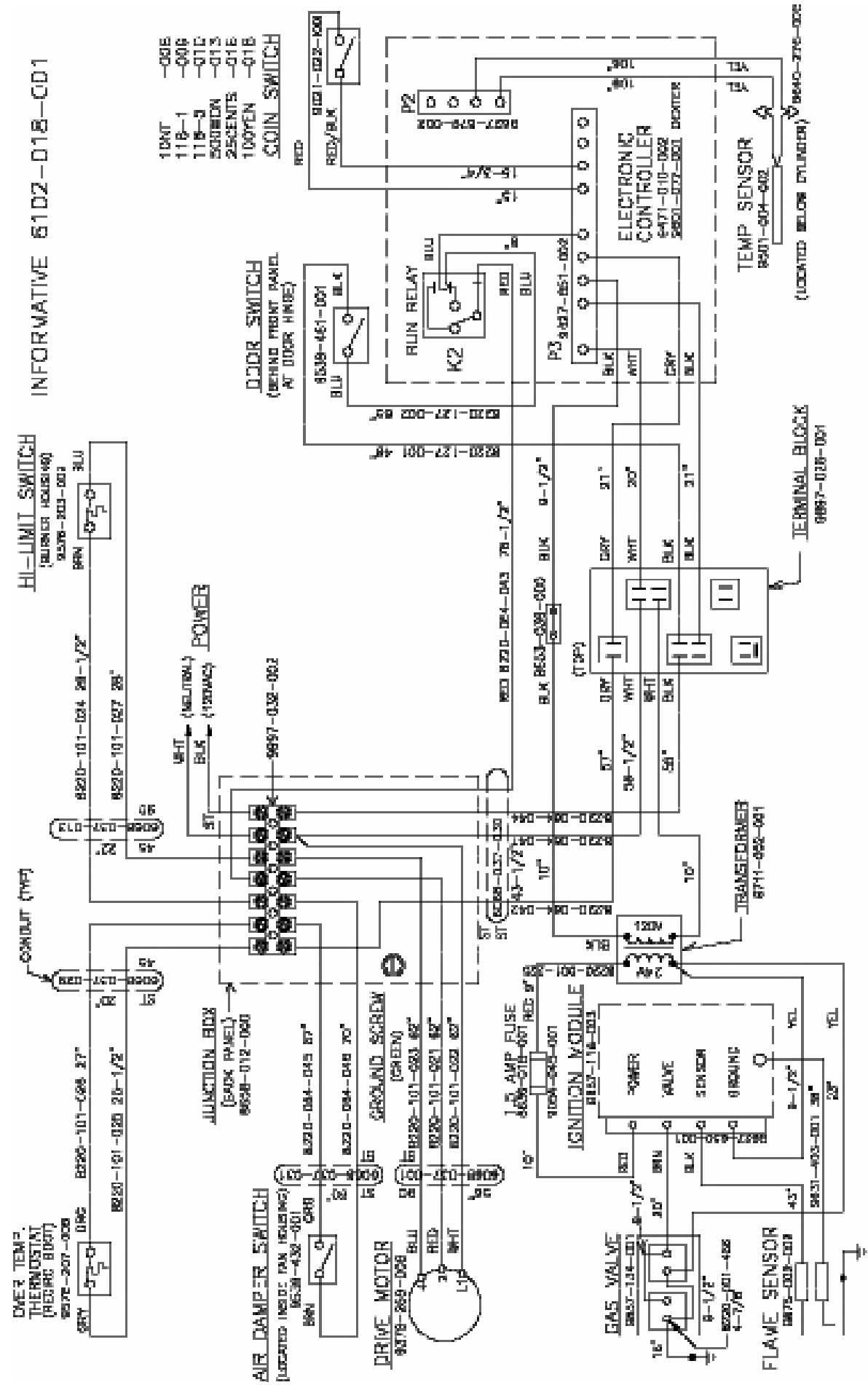

WIRING DIAGRAM

DLC30/DCTD30KC\_10 6CHZ

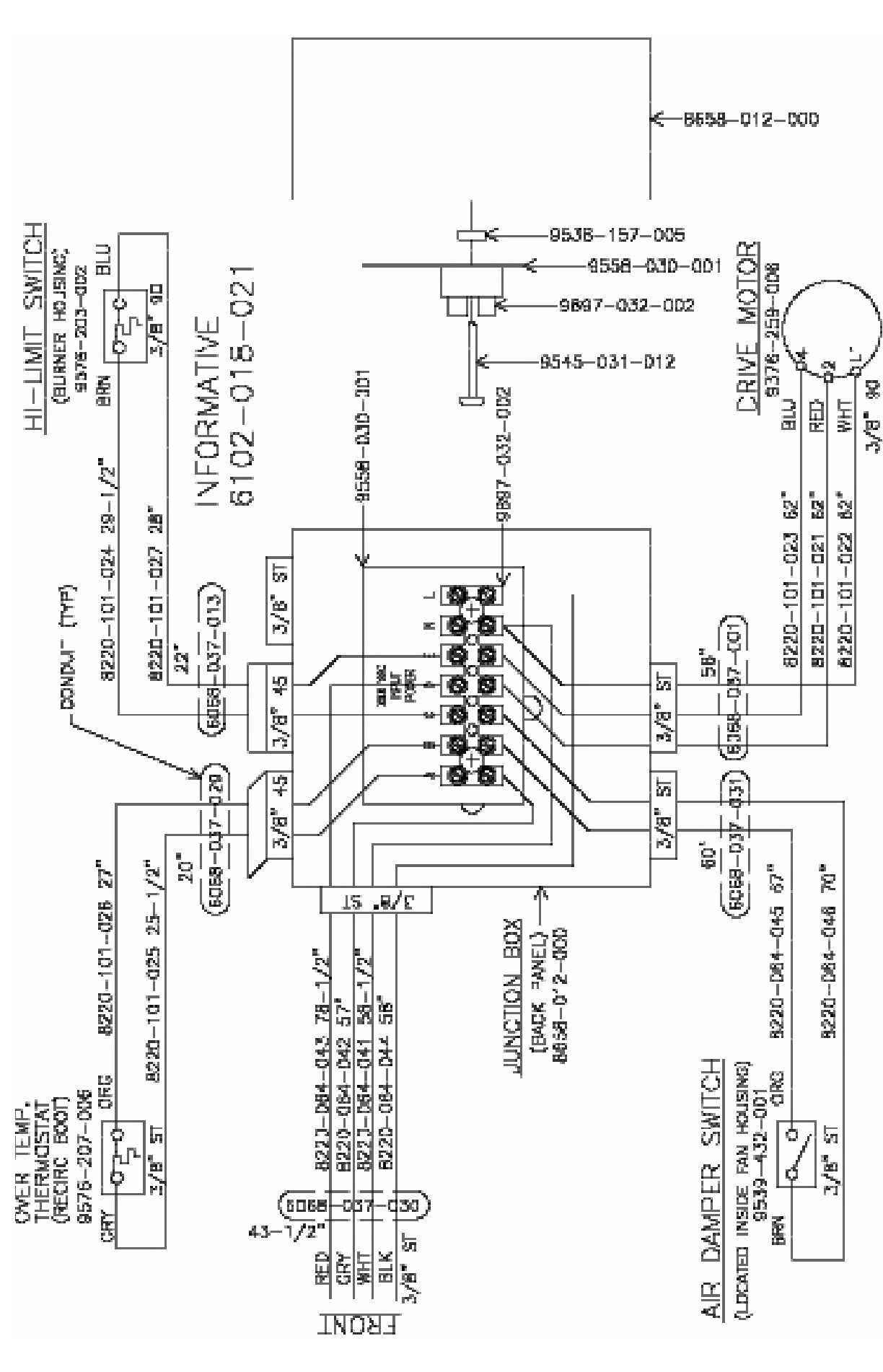

SAMPLE BOX

DLC30 60HZ/DCTD30KC\_10

---

## Section 4: Service Procedures

---

### Clothes Door Removal

**STEP 1:** The clothes door may be removed from the hinge bracket by unscrewing and removing the allen head pivot screw located at the door upper hinge point.

**STEP 2:** Next lean the door out of the top of the hinge bracket and lift the door from the bottom hinge pin.

### Clothes Door Latch Adjustment

**STEP 1:** Loosen the lock nut on the latching stud. It is located directly behind the door handle.

**STEP 2:** Open the loading door.

**STEP 3:** Screw the door catch stud in or out as necessary and then retighten the lock nut.

### Installation of Clothes Door Window & Gasket

**STEP 1:** Remove the loading door.

**STEP 2:** Place the clothes door, with its face down, on a solid surface.

**Note:** Pre-warming the gasket under a heat lamp makes the installation much easier.

**STEP 3:** Put the door glass gasket on the loading door with the ridges in the wide side up. Locate the seam at the door latching stud.

**Note:** The gasket has one narrow opening on one side and a wide opening on the other. The narrow side mounts to the door. The wide side holds the glass. The wide side has ridges on one interior lip. This ridged side should go up with the door laying face down.

**STEP 4:** Coat the inside and outside of the gasket with rubber lubricant or liquid soap.

**STEP 5:** Slide the glass into the middle of the gasket with half of the glass above the door and half below the door.

**STEP 6:** While pressing on the glass, use a modified screwdriver (grind the end off so that it is round and put a slight bend in it) and run it around half of the glass.

**STEP 7:** With half of the glass installed, turn the door over and repeat step 6.

**STEP 8:** Insert the modified screwdriver at the 6 o'clock position and pry the glass up enough to install the door glass support spacer (small diameter rubber tube).

## Door Switch Removal & Installation

**STEP 1:** The door switch is located directly behind the hinge plate of the loading door assembly. Open the door for access to the switch area. Remove the two screws holding the switch cover in position. This will allow the removal of the cover and the switch actuator plate. between the thermostat and bracket which must be used to give proper operation.

**STEP 2:** The entire switch box can now be pulled from the front panel opening, creating access to the door switch mounting screws.

**STEP 3:** Remove these two mounting screws and twin nut which frees the door switch and insulating shield. Remove wires.

**STEP 4:** When installing the door switch make certain the insulating shield is reassembled.

**STEP 5:** The actuator plate and switch box cover should be assembled as illustrated in the parts section of this book.

## Door Switch Operation & Testing

The normally open door switch must be closed (0 ohms resistance) for the motor and heat circuits to operate. When the door is opened, the door switch breaks the 24 volt control circuit.

## Door Switch Adjustment

**STEP 1:** Remove the two switch box cover screws.

**STEP 2:** Remove the switch cover and actuator plate.

**STEP 3:** Pull the entire switch box out from the opening in the front panel.

**STEP 4:** Loosen the bottom door switch mounting screw.

**STEP 5:** A slotted mounting allows the switch to slide in or out for adjustment.

## High Limit Thermostat Locations & Functions

### Burner Housing

This hi-limit is located on the left side of the burner housing.

**STEP 1:** The thermostat opens the circuit to the main burners in the event of malfunction in the gas control area or temperature control. This thermostat will open quickly if there is a significant loss of air flow over the burner area.

**STEP 2:** It is covered by a guard and is held in place by two screws. There are spacers between the thermostat and bracket which must be used to give proper operation.

## Manual Resettable Over Temperature Safety Thermostat

The second hi-limit thermostat is located outside the rear exhaust opening mounted on the exhaust recirculation duct at the rear outlet burner height.

**STEP 1:** The manually resettable thermostat limits the operating temperature a dryer can reach should some abnormal situation occur.

**STEP 2:** Should the thermostat be tripped, the dryer will cease to heat until the thermostat is reset. Once the dryer cools, the thermostat may be reset by inserting a pencil or stick through the opening in the thermostat cover and pushing the button in.

**REMOVAL:** To remove the manual resettable over temperature safety thermostat on the exhaust recirculation duct, remove cover mounting screws holding its respective guard. Next, remove the terminals of each wire attached to the thermostat. Lastly, remove mounting screws holding the thermostat to the recirculation boot.

## Pressure Regulator Adjustment

Use the following procedure whenever it is necessary to check the pressure regulator setting. NOTE: Any adjustment of the pressure regulator must be made with a manometer attached at the plug in the main burner manifold.

**STEP 1:** Shut off the gas supply to the dryer.

**STEP 2:** Remove the 1/8" pipe plug from the end of the main burner manifold.

**STEP 3:** Attach a manometer to the manifold end.

**STEP 4:** Remove the pressure regulator cover screw on the gas valve.

**STEP 5:** Open the shut-off valve, and operate the dryer.

**STEP 6:** Adjust the pressure for a manometer reading of 3.5" water column gas pressure. (11.0" for L.P.)

**NOTE:** The main burners must be operating when adjusting the pressure regulator.

**STEP 7:** Shut off the gas supply to the dryer. Remove the manometer and install the 1/8" pipe plug in the manifold.

**STEP 8:** Open the shut off valve, start the dryer and check for gas leaks while the burners are ignited.

## Front Panel Removal

To remove the front panel, first remove the loading door from the panel. Then remove the two left side screws and the four right side screws. The trim does not have to be removed. (The panel may be removed with the door left in place, although it is much heavier and more awkward to do so.)

**NOTE:** Always remove power from the machine before changing drive belts or working with the drive and fan system.

## Final Drive Belt Replacement

To replace the final drive belt turn the cylinder slowly by hand and work the belt off of the large pulley.

## Motor Drive Belt Replacement

To replace the motor drive belt the final drive belt should be removed as above. Next turn the intermediate drive pulley and work the belt off of it similarly to the above belt.

## Blower Impeller Removal

Remove the lint hood that is located inside the lower service door. Take notice of the location of the impeller location on the shaft. Remove the two set screws that hold the motor to the shaft.

## Airflow switch removal and adjustment

The air switch assembly is part of the ignition safety circuit and insures that the burner doesn't operate unless there is airflow. If this doesn't happen, ignition will not occur. The air switch assembly is located inside the lint compartment on top of the blower housing.

## Electronic Ignition Module

This machine uses an electronic spark ignition system to directly light the burners.

**STEP 1:** The electronic ignition module (gray box) is located inside the upper access door in the control box.

**STEP 2:** The red wire from the transformer provides 24 VAC through the 1.5 amp fuse and into the module to operate the entire direct ignition system.

**STEP 3:** The black colored hi-voltage wire (spark plug type) plugs onto the post connector on the module, and the multi-wire plug fits into the side of the module.

## Spark Electrode Assembly-Removal

**STEP 1:** Remove electrode cover and disconnect wires to electrodes.

**STEP 2:** Remove two screws to detach electrode assembly.

**NOTE:** Proper grounding of the ignition system (yellow wires) is very critical for proper ignition sequence

If there is no spark or intermittent spark, check black hi-voltage lead wire for damage or cracks in insulation. *This lead wire must not be taped or connected to any metal edges along its length to prevent pinching and arcing. Also, do not bundle this wire with other wires.*

**NOTE:** Spark gap and electrode location are important. If the electrode is damaged or mounting is changed the spark gap may not be correct for ignition to occur. Check for cracks in the ceramic insulator. Replace electrode assembly if necessary. Also check for carbon or foreign material on the electrodes and clean if necessary.

## Gas Valve & Manifold Removal

**STEP 1:** Disconnect union at gas valve and disconnect wires from gas valve operator coils.

**STEP 2:** Remove right manifold mounting bracket screws and slide manifold to remove from left bracket.

## Spark Electrode Assembly-Function

1. The spark electrode and sensing electrodes are located directly at the side of the burner housing.
2. The electrode with the black hi-voltage wire conducts the spark to the center grounding probe, directly over the burner.
3. The electrode with the black sensing wire detects ignition and monitors flame by signaling the module.

**NOTE:** Proper grounding of the ignition system (yellow wires) is very critical for proper ignition sequence.

## Ignition System-Function & Sequence

During normal dryer operation, the following occurs:

1. The dryer electronic control calls for heat.
2. From the 24VAC control transformer, voltage for the heat circuit is applied to the control through the door switch. If the control detects that the heat should be on, a circuit is closed providing power through the over-temp thermostat, the air damper switch and the motor centrifugal switch to the Ignition Module. Once the 24VAC reaches the ignition module on the red wire, sparking occurs at the ignition electrode and 24VAC is applied to open the Gas Valve.
3. Once the flame is established, the sensing electrode detects the presence of flame and the sparking stops.
4. If for any reason the flame is not established in a period of 10 seconds, the electronic control will try this sequence for 3 tries. Normally the 10 seconds "Trial For Ignition" period is ample to establish and prove flame.
5. If the flame is shutdown or blown out during operation, the ignitor will immediately go into "Trial. For Ignition" again for 10 seconds.
6. However, at the end of 3 separate retries of 10 seconds "Trial for Ignition", the flame is not established, the ignition system goes into "Safety Lock-Out" and will not reactivate the "Trial for Ignition" until there is a current interruption for a period of 15 seconds. This interruption can be provided by opening the dryer loading door and allowing the machine to come to a complete stop for 15 seconds.

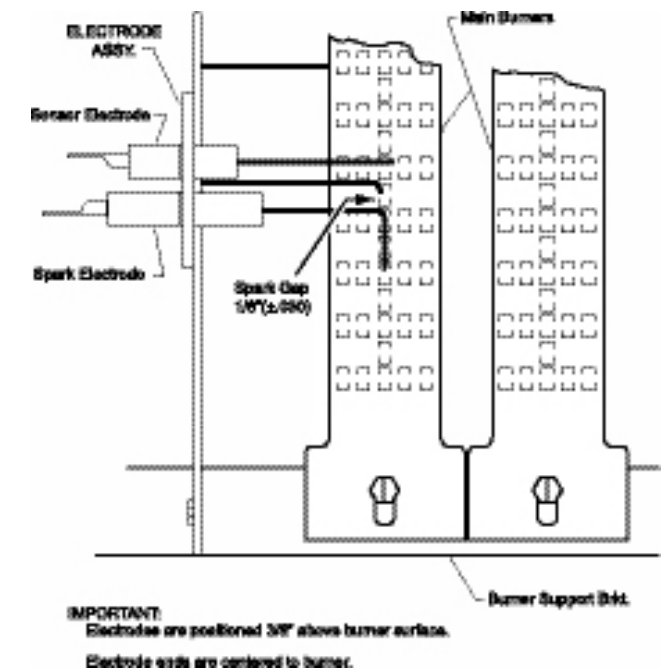

---

## Main Burner Orifice Removal

**STEP 1:** Remove manifold and gas valve assembly as above.

**STEP 2:** Using an open end wrench, remove orifices from manifold.

## Main Burner Removal

Remove manifold & gas valve assembly as previously discussed. Remove the screw securing the front of the burner to the support bracket. The burner may now be removed.

## Cylinder Pulley Removal

Remove nut holding pulley to cylinder shaft. Pull pulley straight off of shaft.

## Intermediate Pulley Removal

The intermediate pulley can be removed by removing the snap ring holding the pulley to the tension arms.

## Tension Arm Assembly Removal

The tension arm assembly may be removed by removing the snap ring that holds it to the tension arm support assembly pin. If it is necessary the arm assembly is replaced as a complete unit.

## Tension Arm Support Assembly Adjustment

The tension arm support assembly may be adjusted for alignment of the intermediate pulley and also to align the belts. The three outer nuts allow the alignment of the pin to be adjusted by pivoting the assembly on the center bolt. The center bolt can be screwed in to allow bringing the complete assembly farther back if necessary for belt alignment.

## Cylinder Removal

**STEP 1:** Remove the front panel in front of the cylinder.

**STEP 2:** Remove drive belt, nut, pulley, and shaft key.

**STEP 3:** Pull the cylinder from the front of the machine.

---

## Adjustment of Cylinder Assembly

**STEP 1:** Loosen the two top adjusting bolts and two bottom adjusting nuts and lock nuts holding the bearing housing to the drive plate.

**STEP 2:** Loosen the four mounting bolts on the side channels.

**STEP 3:** Open the clothes door and insert a 1/2" thick shim at the 3 and 9 o'clock positions and a 1/4" thick shim at the 6 o'clock position.

**STEP 4:** Tighten the two bottom adjusting nuts and tighten locking nuts.

**STEP 5:** Tighten the bottom right mounting bolt, then the top left mounting bolt. Tighten the remaining two bolts. (Shim where and if necessary.)

**STEP 6:** Tighten the two top adjusting bolts.

**STEP 7:** Remove all the shims from between the front panel flange and cylinder (3,6,9 and 12 o'clock).

**STEP 8:** Spin the cylinder to check for rubbing baffles, pressing down hard while rotating. If rubbing is detected, repeat procedure paying particular attention to placement of shims between bearing housing and side channels.

## Bearing Housing Removal

After removing cylinder as previously outlined, simply unbolt the bearing housing and remove.

## Section 5: Trouble Shooting

## Section 5: Trouble Shooting - Gas Heated

Symptom	Probable Cause	Suggested Remedy
Tumbler does not turn	Drive belts	Check both drive belts
	Drive motor	Check capacitor and motor
	Door switch	Check door switch contacts and adjustment
	Micro control	Check that LED's are lit and green start key pushed
	Motor Relay	Check motor relay coils (24v) and contacts.
Tumbler turns but no spark temperature	Temperature	Check for selected in formula at burner
	Spark Electrode	Check electrode for damage to electrode or mounting
	Temperature Sensor	Check by plugging in good sensor
	Ignition Transformer	Check for 24 V out of transformer to ignition control
	Ignition control Air flow switch	Try another control Check for circuit through air flow switch
	Hi-limit	Check hi-limit
	Over-temp	Check by inserting pencil eraser side thru (Manual Reset) hole and push to reset
	Gas supply	No gas can cause system lockout check for W.C.

Symptom	Probable Cause	Suggested Remedy
Tumbler turns ignition sparks no flame	Gas supply	Make sure gas supply is working
	Gas pressure	Make manometer check of gas pressure for 3.5"W.C. natural 11"W.C. propane
	Spark electrode	Check electrode for damage to electrode or mounting
	Gas valve	Check coil continuity, replace valve if bad
Slow drying	Thermostat	What is temperature set at on control
	Air flow Restrictions	Follow installation guidelines for static back pressure and make up air
	Lint screen	Clean screen
	Exhaust	Check complete exhaust system for excessive back pressure in the duct work. No more than .3 static pressure
	Makeup air	Check for adequate makeup air (1.25 sq. Ft.)
	Temp sensor	Clean or replace sensor if necessary
	Gas	Gas pressure at burner should be ( 3.5" W.C.) while burning
	Blower Impeller	Check impeller for operation and check mounting set screw
	Steam & Electric Heated	Check relay for activation. Check steam Check steam valve for steam trough

## Dryer Fault Codes

FAULT#	FAULT DESCRIPTION	ACTION
F1	Shorted thermostat sensor	Dryer stops and "F1" flashes on the 4- digit display. When short circuit on sensor input is removed, "LOAD" appears on the 4-digit display and the remaining dry time is reset.
F2	Open thermostat sensor	Dryer stops and "F2" flashes on the 4-digit display. When a good sensor is connected to sensor input, "LOAD" appears on the 4-digit display and the remaining dry time is reset.
F3	EEPROM corrupted.	Dryer will not start and "F3" appears on the 4-digit display. The power to the dryer must be cycled to reset the controller. Fault should only occur when starting a dry cycle.
F4	Gas valve on fault.	The drying temperature did not increase 1°F. in 5 minutes. "F4" will flash on the display and the dry cycle will finish without calling for heat (energizing gas valve). Opening the door or pressing the STOP key will reset the fault and clear the remaining time in the dry cycle.
F5	Temperature fault.	The drying temperature is at least 25°F. above the temperature setting. "F5" will flash on the 4-digit display and the dry cycle will finish without calling for heat (energizing the gas valve). The power to the dryer must be cycled to reset the controller.

## Kits, Assemblies, & Common Parts

Coin Acceptor Components	Part Number
Mechanical Coin Acceptor	9021-002-016
Coin Drop Screws	9545-053-002
Retainer, Coin Acceptor	9486-149-001
Loading Door Components	Part Number
Door Handle	9244-082-001
Door Close Switch	9539-461-001
Electrical Components	Part Number
Transformer, Control	8711-007-001
Transformer, Ignition	8711-002-001
Controls	9471-010-002
Heating Circuit Components	Part Number
Ignition Control Module	9857-116-003
Ignition Electrode Assembly	9875-002-003
Thermostat, Hi-Limit	9576-203-002
Thermostat, Overtemp	9576-207-006
Fuseholder	9200-001-002
Fuse 1.5 amp	8636-018-001
Airflow Switch	9539-461-009
Cabinet Components	Part Number
Cleanout Duct Assembly 8"	9973-034-001

## Section 6: Parts Data

## Cabinet Group

Key	Part Number	Description	Qty
•	9960-256-021	Door Assembly, Loading Complete-WHT	1
•	9960-256-022	Door Assembly, Loading Complete-ALM	1
•	9960-256-025	Door Assembly, Loading Complete-SS	1
1	9960-255-007	Door Assembly Only, Loading SS	1
2	9982-280-002	Plate Assembly, Hinge-WHT	1
2	9982-280-005	Plate Assembly, Hinge-ALM	1
2	9982-280-011	Plate Assembly, Hinge-SS	1
•	9545-012-015	Screw, Hinge to Door #10-32x 3/8	4
•	8640-413-002	Nut, Hinge to Door #10-32UNF	4
3	9212-002-003	Glass, Door	1
4	9206-164-009	Gasket, Glass	1
•	9548-117-000	Support, Door Glass (inside Gasket)	3
5	9206-420-002	Gasket, Outer Rim	1
6	9244-082-001	Handle, Loading Door	1
•	9545-018-017	Screw, Handle 1/4" 20 x 3/8"	2
•	9531-033-001	Stud, Door Catch	1
•	8640-413-001	Nut, Hex	1
•	8640-413-003	Nut, Acorn # 10-32	1
•	9086-015-002	Catch, Loading Door	1
•	8638-190-009	Rivet, Pop-Catch loading door	2
7	9454-569-005	Panel Assembly, Front WHT	1
7	9454-569-008	Panel Assembly, Front ALM	1
7	9454-569-010	Panel Assembly, Front SS	1
8	9108-084-010	Door, Upper Service WHT	1
8	9108-084-013	Door, Upper Service ALM	1
8	9108-084-014	Door, Upper Service SS	1
9	9578-085-001	Trim, Upper Service Door	1
•	9491-009-001	Rivet, Drive-Door Hinge	2
•	8641-581-005	Washer, Flat 3 /16	2
•	9548-268-001	Support, Upper Door	1
•	8650-006-003	Lock w/nut Lower Service Door	1
•	6292-006-006	Key, Service Lock (FJWCC)	1
10	9412-083-001	Nameplate, Commerical Dryer	1
•	9545-012-003	Screw, Chrome 10-32 x 1/2	4
•	8641-436-004	Washer, Fiber	4
•	8641-582-019	Lockwasher #10	10
•	8640-399-001	Nut, Spring U Type 10Z-Front Panel Clips	6
11	9544-047-002	Strap, Hinge-WHT	1
11	9544-047-005	Strap, Hinge-ALM	1
11	9544-047-007	Strap, Hinge-SS	1
•	9545-012-028	Screw, Hinge To Panel 10T-32 x 1/2	4
12	9545-052-001	Screw, Door to Hinge Strap (special)	1
•	8641-436-003	Washer, Fiber/Plastic VSCO on Door Hinge (special)	1
13	9960-243-022	Door Assembly, Lower Service WHT	1
13	9960-243-025	Door Assembly, Lower Service ALM	1
13	9960-243-026	Door Assembly, Lower Service SS	1
14	9578-081-002	Trim-Handle, Lower Service Door	1
•	9545-008-021	Screw, Pn Hd Cr-#10 x 3/8	1
15	9578-084-001	Trim, Kick-Lower Service Door	1
*	9472-001-013	Cabinet Touch Up Paint (White)	1

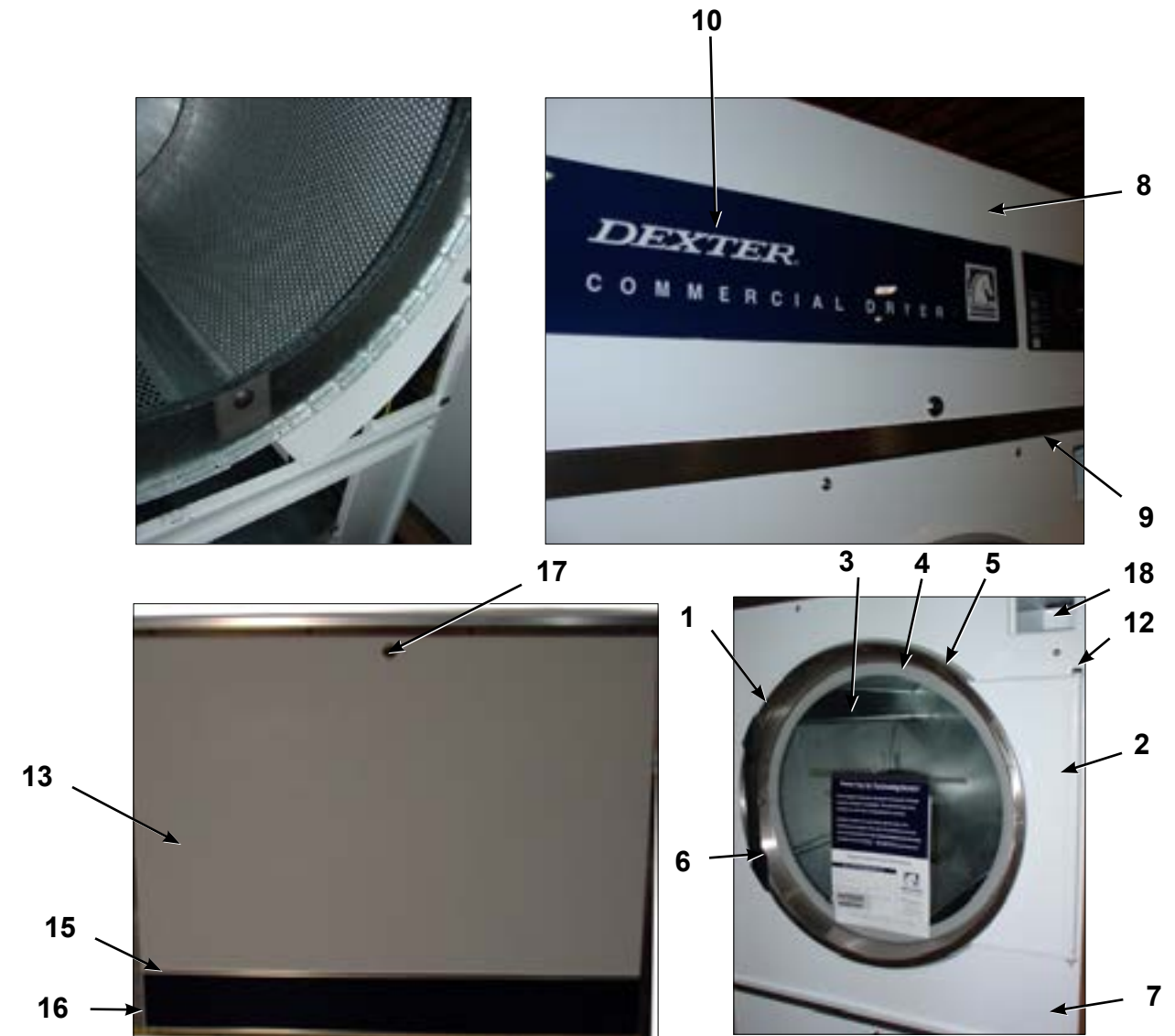

Key	Part Number	Description	Qty
16	9435-004-001	Overlay, Trim Kick	1
•	9545-008-010	Screw, Tr Hd Cr #10 x 1/2 BLK	3
17	8650-006-003	Lock w/nut Lower Service Door	1
•	8502-617-001	Label-Made in the USA	1
18	9942-027-002	Vault Assembly, Coin - SS	1
18	9942-027-004	Coin Vault Assembly White	1
18	9942-027-003	Coin Vault Assembly Almond	1
•	9807-099-001	Box Assembly Coin Vault ESD W/lock & Key Chrome	1
•	9277-041-002	Insulation Side Pannel	1
•	9277-041-004	Insulation Side Pannel	1
•	9277-047-001	Insulation 1/4" Black Top LH Side Burner Area	1
•	9277-047-002	Insulation 1/4" Black Service Door	1
•	8544-006-001	Leg, Leveling	4
*	8545-061-002	Leveling Leg Wrench	1
•	9545-008-003	Screw, #10 x 1/2 TEK	8
•	9074-236-001	Cover, Cabinet	1
*	8640-413-004	Nut, Elastic Stop	*

## Front Control Housing Group

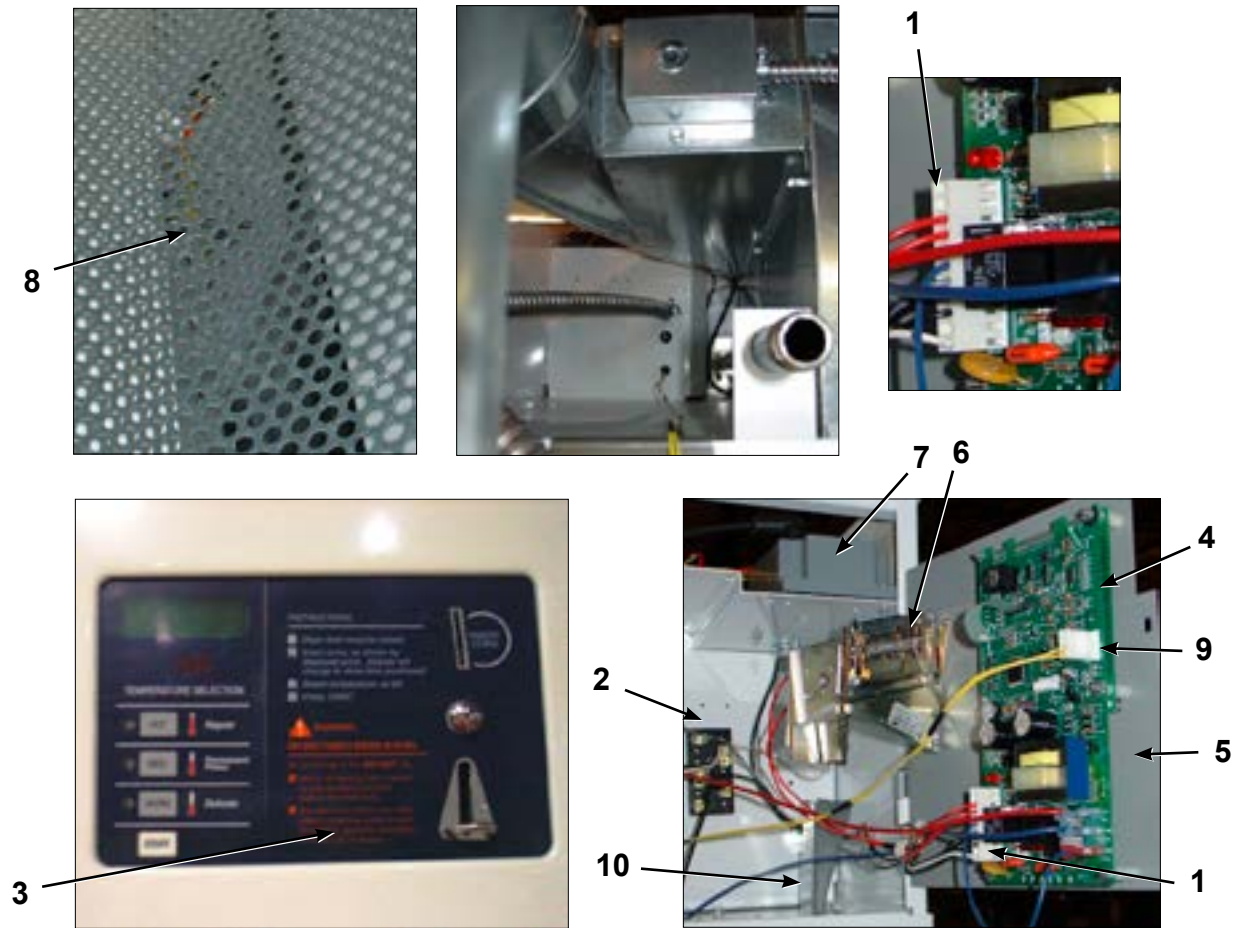

Key	Part Number	Description	Qty
1	9627-651-002	Harness Assembly, Micro	1
2	9897-026-001	Terminal Block Assembly	1
•	9545-031-004	Screw, 6AB x 3/8" (for Terminal Block)	2
3	9801-077-001	Membrane, Switch Assembly	1
3	9801-058-005	Membrane Switch Assembly (DLC30 Only)	1
4	9471-010-002	PCB Board Control	1
•	8651-053-003	Plug, Button	1
5	9982-305-002	Plate Assembly, Control Mounting	1
•	9451-146-005	Pin-Hinge Meterplate	2
6	9021-002-016	Acceptor-Coin 25¢	1
•	9054-045-001	Fuse Holder	1
•	8636-018-001	Fuse 1.5 Amp	1
•	8711-002-001	Transformer-Control	1
7	9857-116-003	Control, Ignition	1
•	9627-650-001	Harness Assembly, Low Voltage	1
•	9631-403-001	Wire Assy High Voltage (From Ignition Control)	1
8	9501-004-002	Temperature Sensor	1
9	9627-679-002	Wire Harness, Temp Sensor	1
•	8640-276-005	Nut, Wire connector 71B, BLK	2
•	9452-614-001	Bracket Sensor Mounting	1
•	9545-045-005	Screw, Mounting Bracket 8B x 1/4	1
10	9940-013-001	Coin Chute Assembly	1

## Drive Group

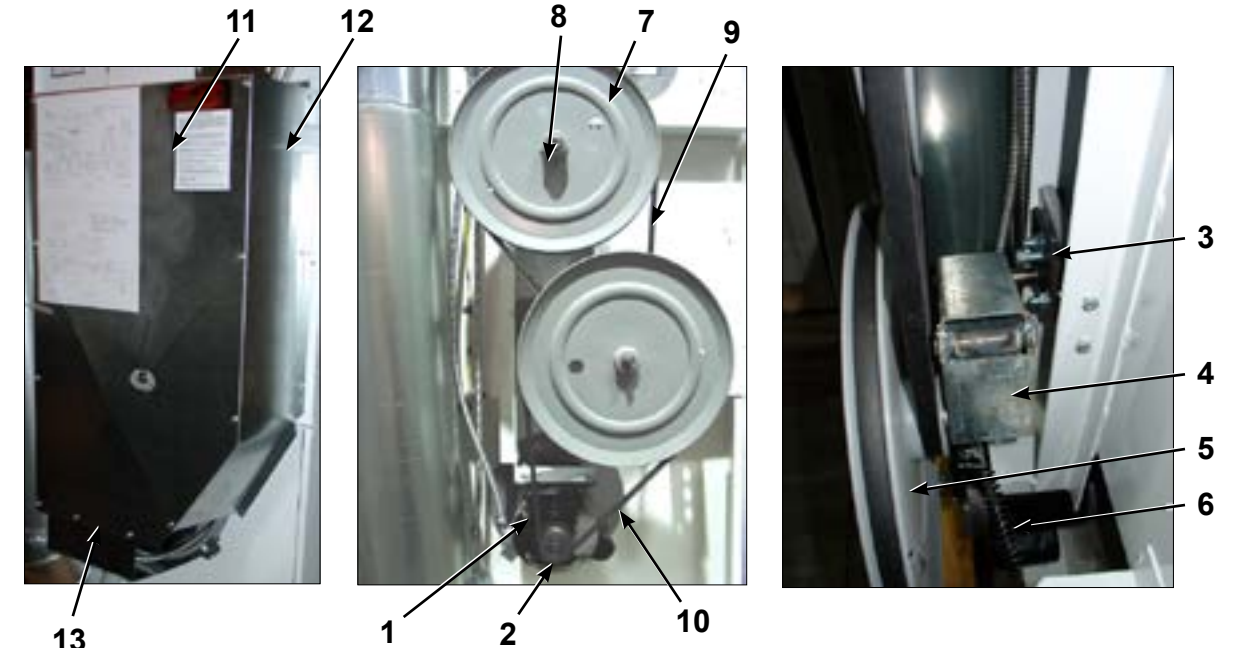

Key	Part Number	Description	Qty
1	9376-259-006	Motor, Drive AO Smith before serial #210650	1
*	9732-205-006	Motor Replacement Kit	1
*	5191-106-001	Capacitor, AO Smith Motor Start	1
1	9376-311-001	Motor, Marathon after serial #210650	1
*	5191-107-001	Capacitor, Marathon Motor Start	1
•	9545-014-004	Screw, Hx 5/16-18 x 5/8	4
•	8640-400-003	Nut 5/16 - 18	4
2	9453-157-001	Pulley - Motor	1
•	9545-028-013	Screw, Set	2
3	9991-053-002	Support Assembly, Intermediate Pulley	1
•	9545-029-010	Bolt, Rd Hd, 3/8-16 x 1 1/4	3
•	9545-029-012	Screw, 3/8-16 x 1 1/2	1
•	8640-415-004	Nut, 3/8-16	3
•	8641-581-035	Washer, Flat	3
4	9861-022-001	Arm Assembly-Tension Complete	1
*	9861-015-001	Tension Arm (Short) DLC30 Only	1
*	9861-016-001	Tension Arm DLC30 Only	1
5	9908-039-001	Pulley Assembly, Intermediate-W/Bearings	1
•	9036-145-002	Bearings, Bronze Flange	2
•	9487-200-003	Ring, Retaining	3
6	9534-319-002	Spring, Belt Tension	1
•	8641-581-035	Washer, Flat	2
7	9908-040-001	Pulley Driven	1
•	9306-006-000	Key, Woodruff	1
8	8640-222-000	Nut, 1"-14	1
•	8641-582-015	Washer,Lock Internal Tooth	1
9	9040-073-004	Belt, Final Drive	1
10	9040-077-002	Belt, Motor Drive	1
11	9208-065-001	Guard, Drive	1
*	9545-008-024	Guard Screws	*
12	9454-596-002	Pannel, Drive Guard, RH	1
•	9454-595-002	Pannel, Drive Guard, LH	1
13	9550-190-001	Shield, Motor	1
•	9545-008-003	Screw 10-16 x 1/2, TEK	2



## Burner Housing Group

Key	Part Number	Description	Quantity
1	9803-163-002	Housing Assembly, Burner Welded	1
•	9545-008-024	Screw 10AB x 3/8	2
2	9048-018-001	Burner, Main	3
•	9545-008-008	Screw 10 T-32 x 1/4"	3
3	9875-002-003	Electrode, Ignition	1
•	9985-161-001	Bracket Assembly, Electrode Mounting	1
•	9545-008-024	Screw, Electrode Mtg 8B x 10x 3/8"	2
4	9857-134-001	Control Assy, Gas	1
5	9381-009-001	Manifold, 2 port	1
•	9425-069-002	Orifice, Burner-Natural #30	2
•	9425-069-003	Orifice, Burner-LP #48	2
6	9576-203-002	Thermostat, Hi-Limit	1
•	9538-142-001	Spacer, Hi-Limit	2
•	9545-045-007	Screw 8B x 3/4"	2
7	9074-234-001	Cover, Hi-Limit Stat	1
•	9545-008-024	Screw 10 B x 3/8"	1
8	9857-116-003	Control, Ignition (Gray Box)	1
•	9545-044-002	Screw 6-32 x 1"	2
•	8640-411-003	Nut, Hex Keps 6 x 32	2
9	9897-026-001	Terminal Block Power (Inside Control Panel)	1
•	9545-031-004	Screw 6 AB x 5/8"	2
•	9039-915-001	Bracket, Pipe gas line	1
•	9545-008-003	Screw 6AB x 5/8"	2
10	9631-403-001	Wire Ass'y, High Voltage	1
11	9627-650-001	Harness, Low Voltage Ignition	1
12	9054-045-001	Fuseholder	1
13	8636-018-001	Fuse 1.5 amps	1
•	8711-007-001	Transformer, Control	1
•	9545-012-009	Screw, 10x1/2"	2
•	9732-102-003	Kit, LP Conversion	1
•	9548-256-001	Support, Front Burner	1
•	9545-008-008	Screw 10T-32 x 1/2"	3
14	9379-164-001	Valve, Gas Shut-Off w/ brass union (Optional)	1
•	9458-020-003	Pipe, Gas Line	1
•	9918-002-002	Recirculation Boot	1
•	9545-008-024	Screw, 10AB x 3/8"	7
•	9576-207-006	Thermostat, Over Temp-Manual Reset	1
•	9545-045-008	Screw, 8AB x 3/8"	2
16	9825-057-002	Cover, Over Temp Thermostat	1
•	9545-008-024	Screw, 10AB x 3/8"	2

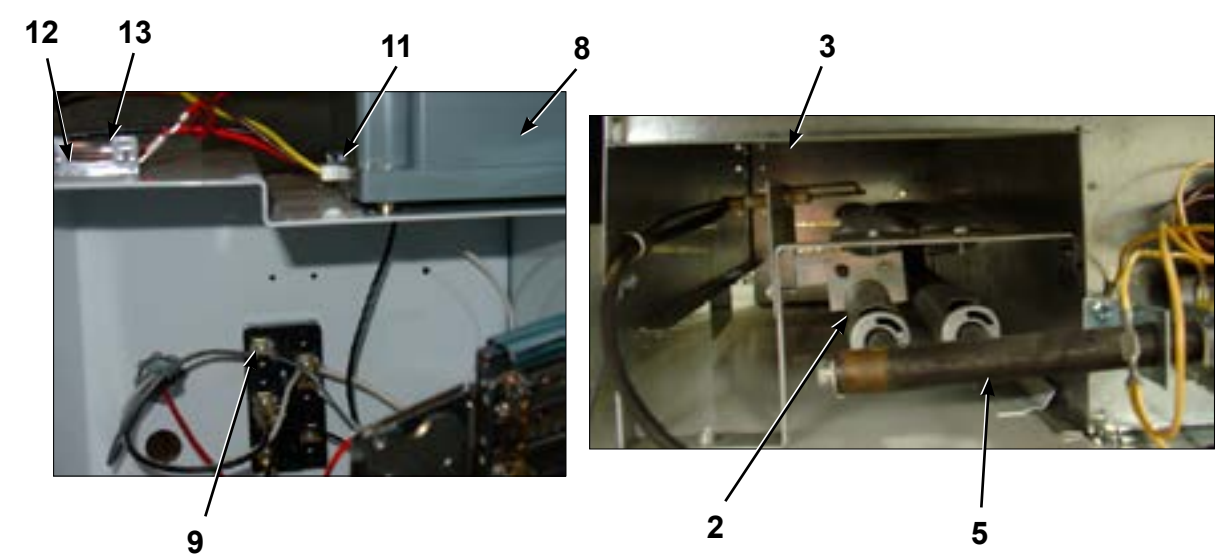
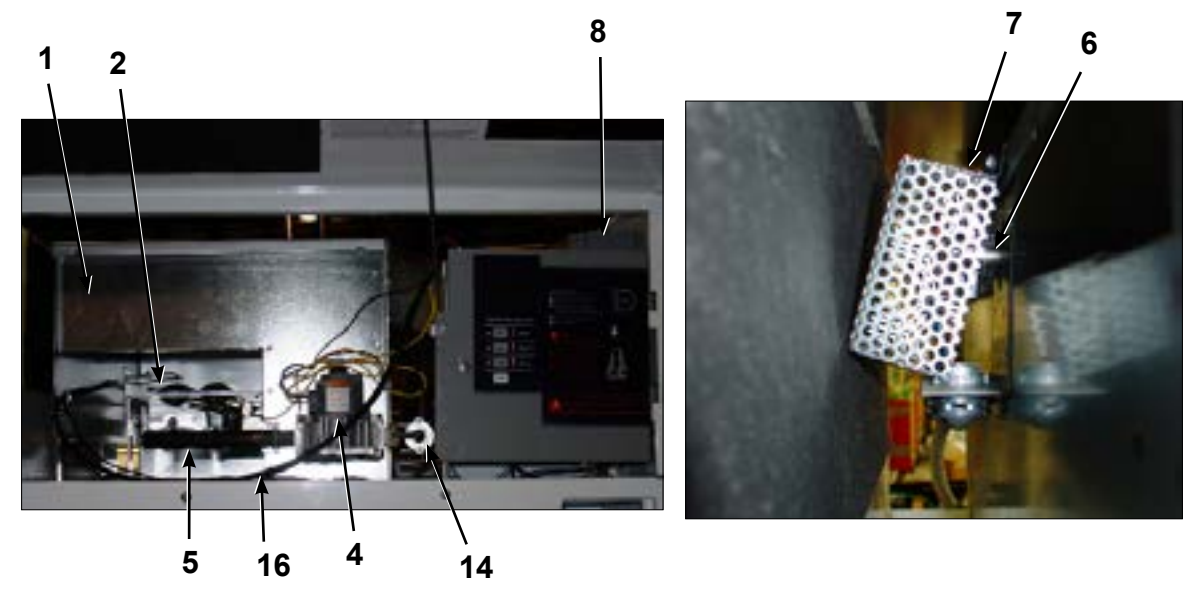
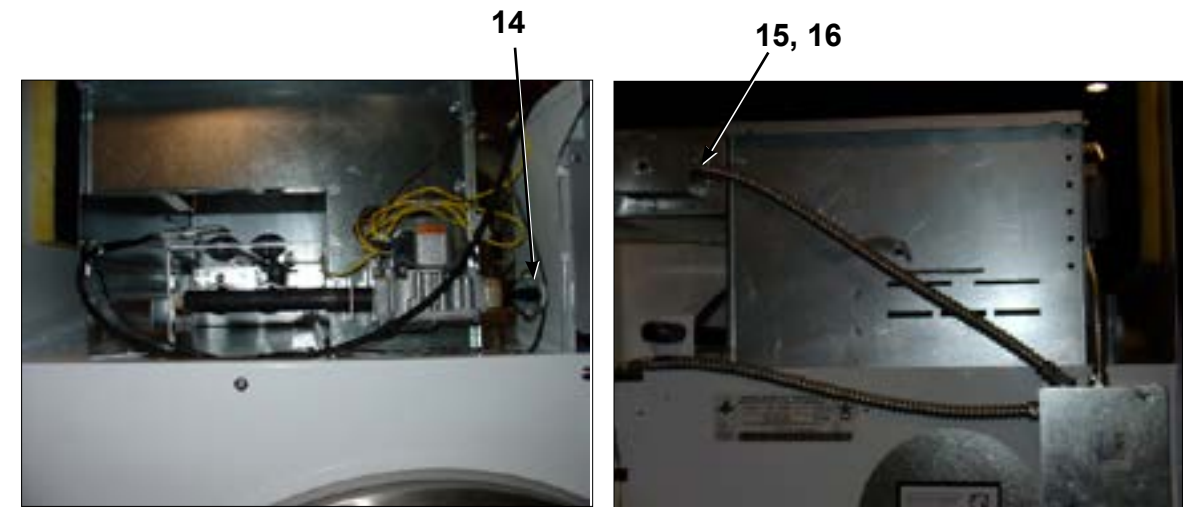

## Bearing Housing Group

Key	Part Number	Description	Quantity
*	9803-160-002	Housing, Bearing Ass'y w one( rear ) bearing .....	1
1	9241-161-001	Housing, Bearing .....	1
2	9036-130-001	Bearing, Ball-Rear .....	1
*	9036-130-001	Bearing, Ball-Front .....	1
	9538-139-001	Spacer, Bearing .....	1
3	8641-581-009	Washer, Flat 3/8" .....	4
4	8641-582-003	Lockwasher spring 3/8" .....	4
5	9545-049-002	Screw 3/8" x 3/4" .....	4
6	8640-415-002	Nut, 3/8" .....	2
*	8640-400-002	Nut, 5/16" .....	4
*	8640-222-000	Nut, Tumbler Shaft .....	1
*	9306-006-000	Key, Tumbler Shaft .....	1
*	9908-040-001	Pulley Drive .....	1
*	9552-013-003	Shim .....	1
8	9545-049-001	Screw 3/8" x 1" .....	2

\* Not Illustrated

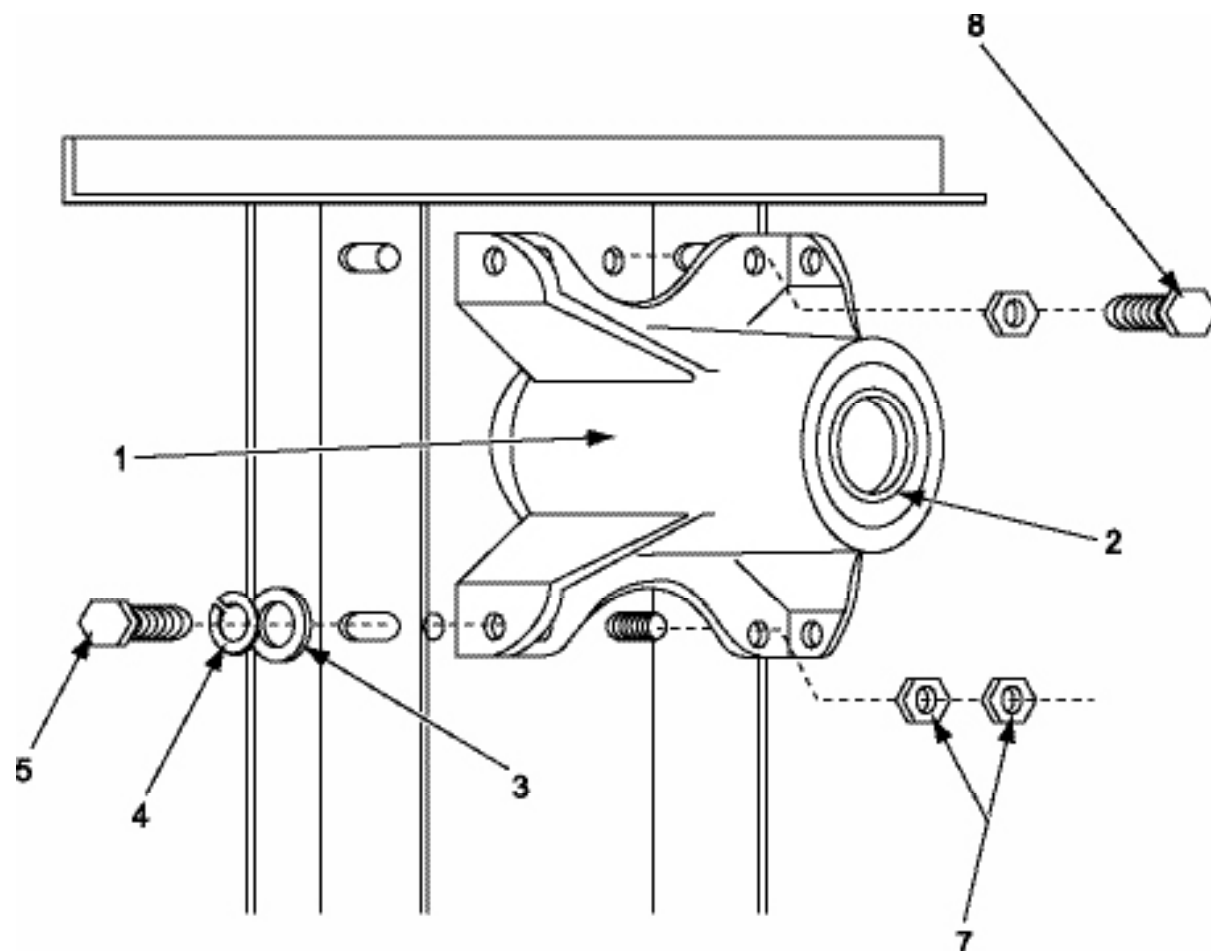

## Tumbler Basket Group

Key	Part Number	Description	Quantity
1	9848-101-001	Tumbler Assy .....	1
*	9848-128-002	SS Tumbler .....	1
2	9568-012-001	Spider & Shaft Assy .....	1
3	9497-019-001	Rod, Tumbler .....	3
4	8640-415-004	Nut, Tumbler Rod .....	3
5	9552-013-003	Shim .....	AR
7	8641-554-001	Washer, Tumbler Rod (special) .....	3
8	9306-006-000	Key, Tumbler Shaft .....	1
9	8641-582-015	Lock Washer, Tumbler Shaft .....	1
10	8640-222-000	Nut, Tumbler Shaft .....	1
*	9848-129-001	Tumbler w/ Spider .....	1

\* Not Illustrated

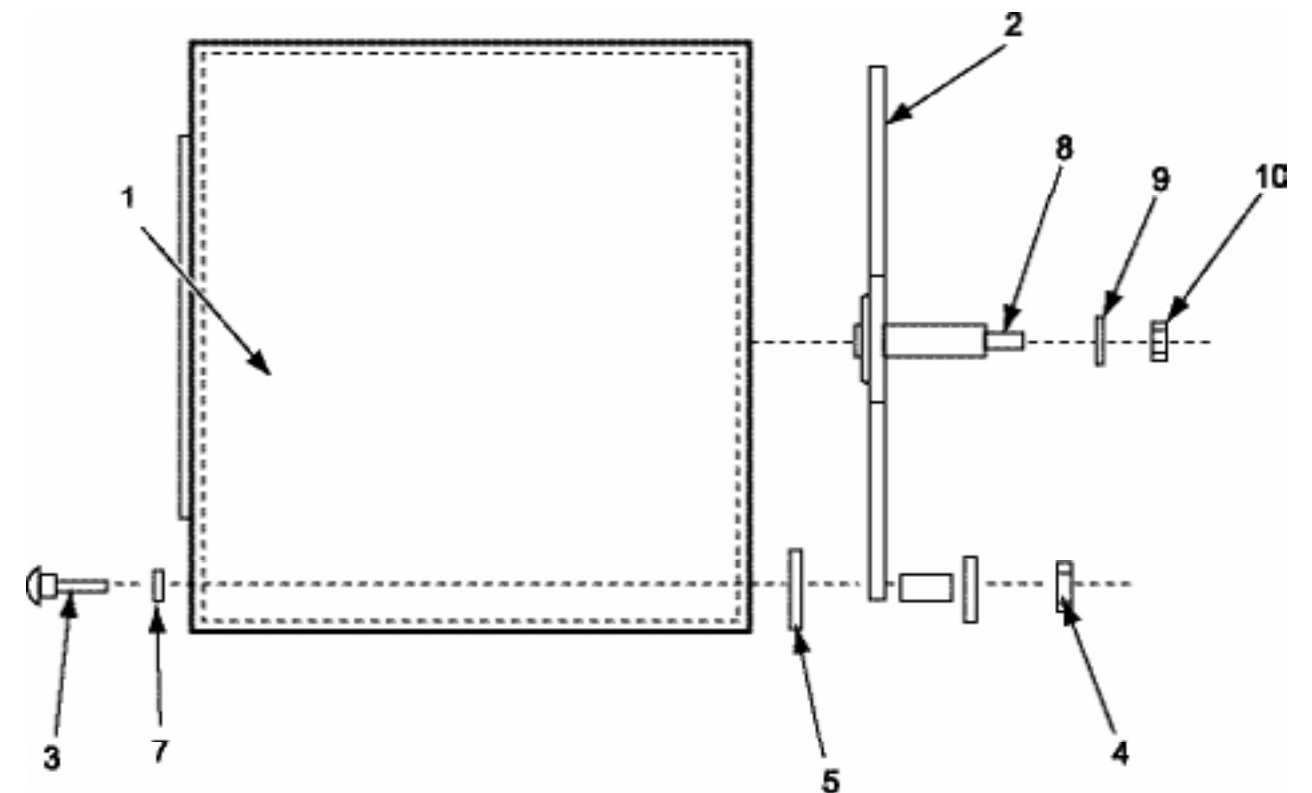

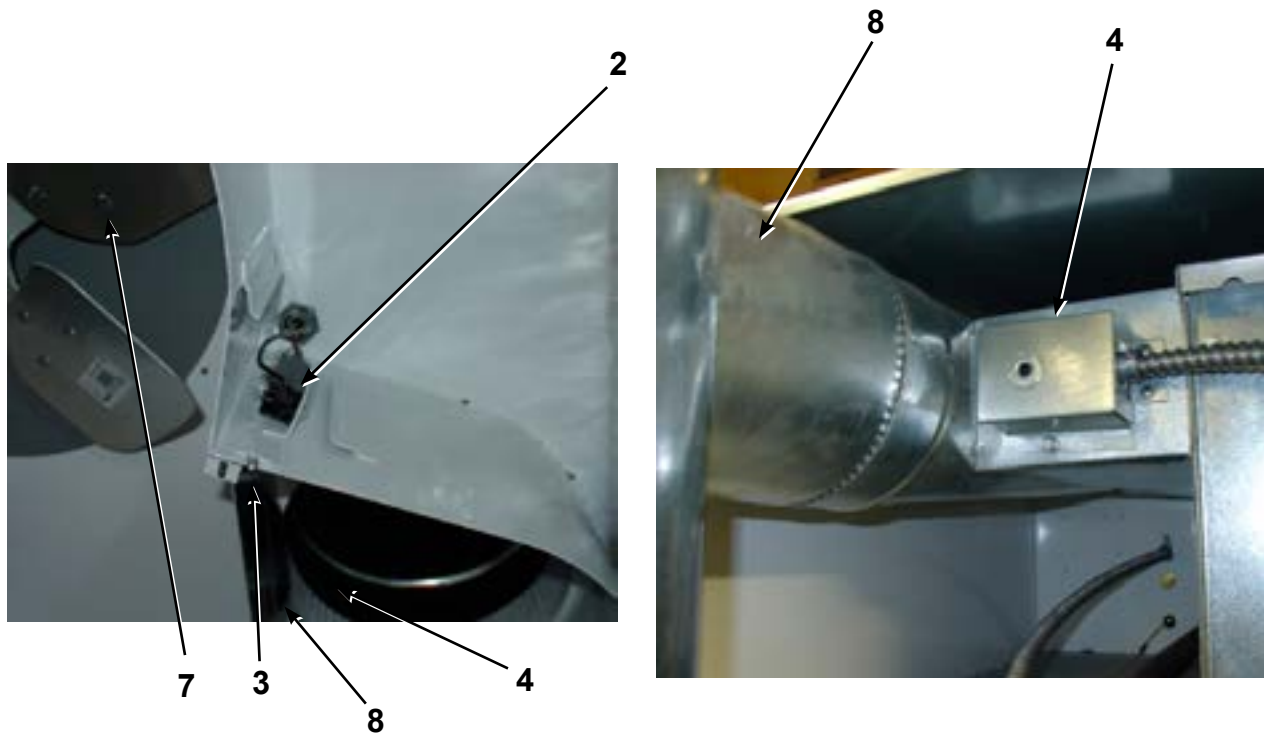

## Blower Impeller and Air Flow Switch Group Over Temperature Switch

Key	Part Number	Description	Quantity
•	9074-242-001	Cover Damper Switch.....	1
1	9125-001-001	Damper.....	1
•	9545-044-002	Screw Switch Mtg. ....	2
2	9539-432-001	Switch Damper .....	1
•	8640-411-003	Nut Switch Locking .....	1
•	8640-420-001	Nut Twin.....	1
3	9451-146-001	Pin Damper.....	1
4	9825-057-002	Over-tempcoverass'y .....	1
•	9576-207-006	Thermostatover-tempMnl.....	1
•	9545-045-008	Screw 10B x 3/8.....	2
•	9486-137-001	Retainer pushon .....	1
•	9535-050-003	Sleeve-Hi-Limitswitcaccess .....	1
5	9822-027-002	Hood Ass'y, Lint .....	1
•	8640-412-004	Lint Hood Mtg. ....	6
6	9822-026-001	Lint Screen.....	1
7	9278-037-002	Impeller, w/set screws.....	1
•	9545-028-013	Set Screw.....	2
8	9918-002-002	Recirculation Boot.....	1
*	9973-034-001	8" Slide Open Clean Out Duct (Optional).....	1

\* Not Illustrated

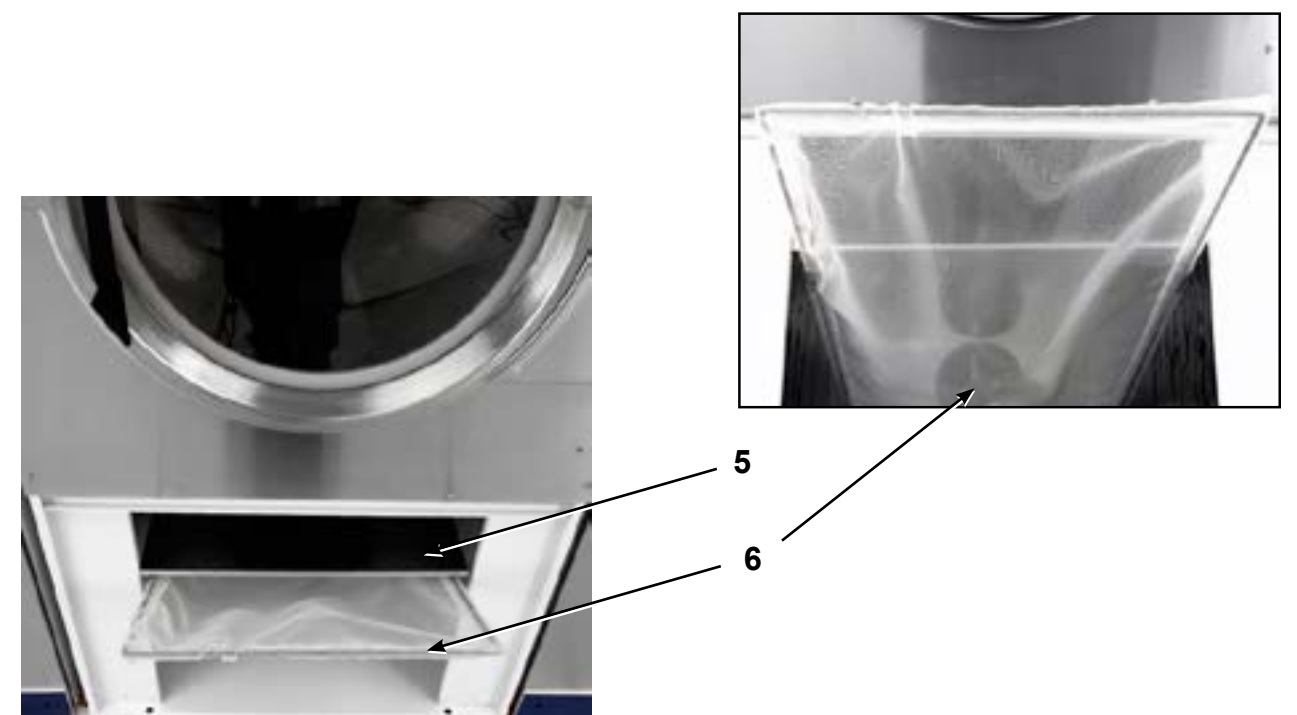
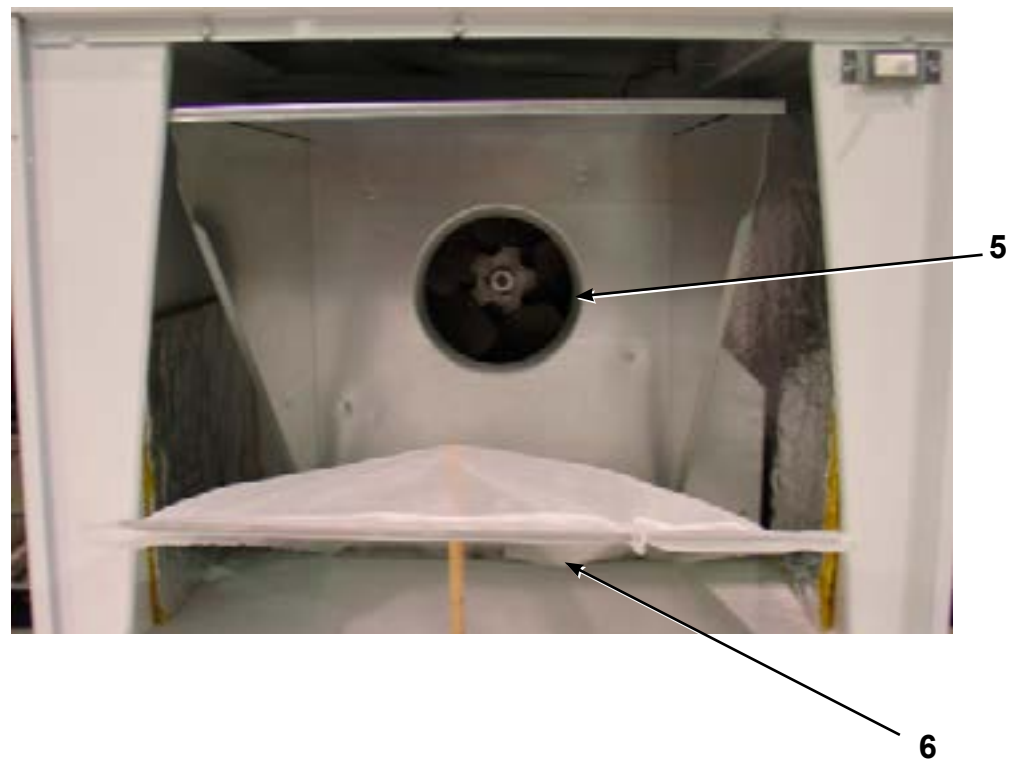

## Wire & Harness Group

Key	Part Number	Description	Qty
	9627-651-002	Harness, Control.....	1
	9627-679-002	Wire Harness, Temp Sensor.....	1
	8640-276-005	Nut, Wire connector 71B, BLK.....	2
	9627-650-001	Harness Assembly, Low Voltage.....	1
	9631-403-001	Wire Assy, High Voltage (From Ignition Control).....	1
	9054-045-001	Fuse Holder .....	1
	8636-018-001	Fuse, 1.5 Amp.....	1
	9897-032-002	Terminal Block, Rear Control Box.....	1
	8220-064-044	Wire Assy, BLK 58", Power Terminal Block to Block.....	1
	8220-064-041	Wire Assy, WHT 58 1/2", Power Terminal Block to Block .....	1
	8220-101-022	Wire Assy, WHT 62", Terminal Block to Motor .....	1
	8220-101-021	Wire Assy, RED 62", Terminal Block to Motor.....	1
	8220-057-034	Wire Assy, BLU 62", Terminal Block to Motor .....	1
	8220-064-046	Wire Assy, BRN 70", Terminal Block to Air Flow Switch .....	1
	8220-064-045	Wire Assy, ORG 67", Terminal Block to Air Flow Switch.....	1
	8220-064-042	Wire Assy, GRY 57", Terminal Block to Terminal Block .....	1
	8220-101-025	Wire Assy, GRY 25 1/2", Terminal Block to Over Temp Switch....	1
	8220-101-026	Wire Assy, ORG 27", Terminal Block to Over Temp Switch .....	1
	8220-101-024	Wire Assy, BRN 29 1/2", Terminal Block to High Limit Switch .....	1
	8220-101-027	Wire Assy, BLU 28", Terminal Block To High Limit Switch .....	1
	8220-064-043	Wire Assy, RED 78 1/2", Terminal Block To Control Board.....	1
	8220-001-225	Wire Assy, RED 9" Transformer to Fuse Holder .....	1
	8220-127-001	Wire Assy, Black 48" Terminal Block to Door Switch .....	1
	8220-127-002	Wire Assy, Blue 65" Terminal Block to Door Switch.....	1
	8653-039-000	Connector-Wire, Line 1/4" .....	1
	8711-002-001	Transformer, Control 120/24 VAC.....	1

## Label Group

Key	Part Number	Description	Qty
	8507-256-001	Instructions, Uncrating.....	1
	8514-003-010	Owner's Booklet.....	1
	8507-350-001	Instructions, Dryer Install / Start Up.....	1
	8507-330-001	Instructions TVSS.....	1
	9506-047-002	Wiring Schematic.....	1
	9506-048-002	Wiring Diagram .....	1
	8511-001-002	Label, Quality.....	1
	8527-105-001	Label, Decal Lighting and Clearance.....	1
	8502-645-001	Label Instructions.....	1
	8502-600-001	Label, Warning and Notice .....	1
	8502-640-004	Label, Instructions.....	1

## Label With Electronic Coin Acceptor Parts

Key	Part Number	Description	Qty
	8220-001-338	Wire Assembly-6" BLU, Transformer to Terminal Block .....	1
	8502-725-001	LABEL-INSTRUCT/WARN,ELECTRCOIN.....	1
	8502-730-001	LABEL-WARNING,ELECCOINACCEPTOR .....	1
	8640-411-002	NUT-ELASTICSTOP,#6-32 .....	2
	8640-424-002	NUT-HEXELASTICSTOP,#4-40 .....	3
	8711-003-001	TRANSFORMER-120/12VAC .....	1
	9021-014-002	ACCEPTOR-COIN,ELECTRONIC(108).....	1
	9452-724-001	PLATE-MOUNTING,COMPUTERCONTROL .....	1
	9506-072-002	WIRINGLABEL-SCHEMATIC.....	1
	9506-073-002	WIRINGLABEL-DIAGRAM.....	1
	9531-040-002	STUD-SELFCLINCHING,#4-40X3/8 .....	3
	9545-044-006	SCREW-PNHDCR,#6-32X5/16.....	2
	9627-651-003	WIRINGHARNESSELECTRONICCNTRL .....	1
	9982-334-002	PLATEASY-CONTROLSMNTNG(CMPTR).....	1

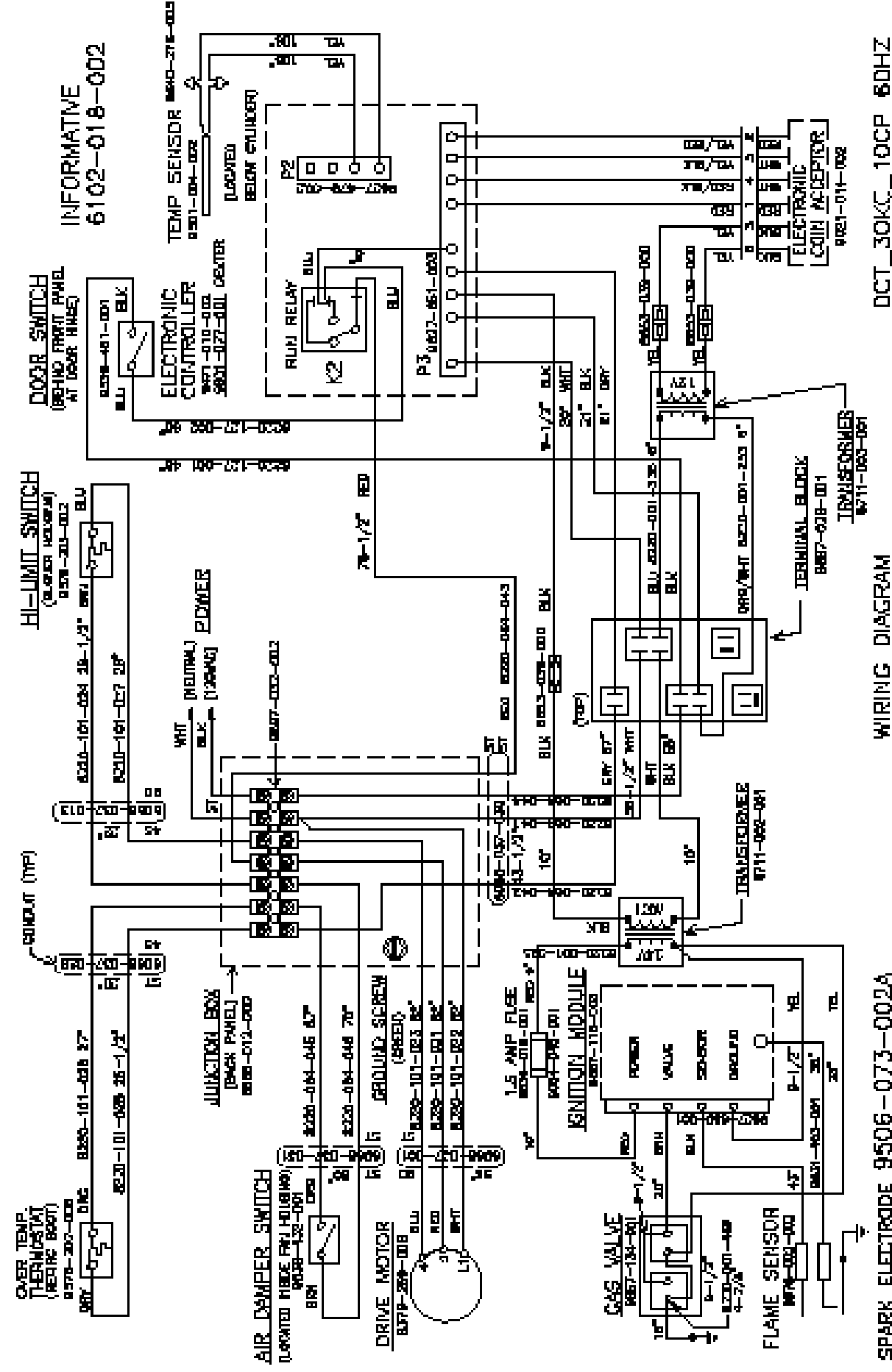

SPARK ELECTRODE 9506-073-002A

WIRING DIAGRAM

DCT\_30KC\_10CP 60HZ

INFORMATIVE  
6102-018-002

NOTES:

1. COIN OUTPUTS—N.O., CLOSED WHEN COIN INSERTED
2. DOOR SWITCH—N.O., CLOSED WHEN DOOR IS CLOSED.
3. MOTOR RUN RELAY CONTACT WILL CLOSE WHEN THE COIN COUNT IS SATISFIED, THE DOOR CLOSED AND THE START BUTTON PRESSED.
4. CENTRIFUGAL SWITCH—CONTACT CHANGES POSITION WHEN MOTOR IS UP TO SPEED.
5. REFER TO OWNER'S MANUAL FOR DESCRIPTION OF OPERATION AND REQUIREMENTS FOR HEATING CIRCUIT.

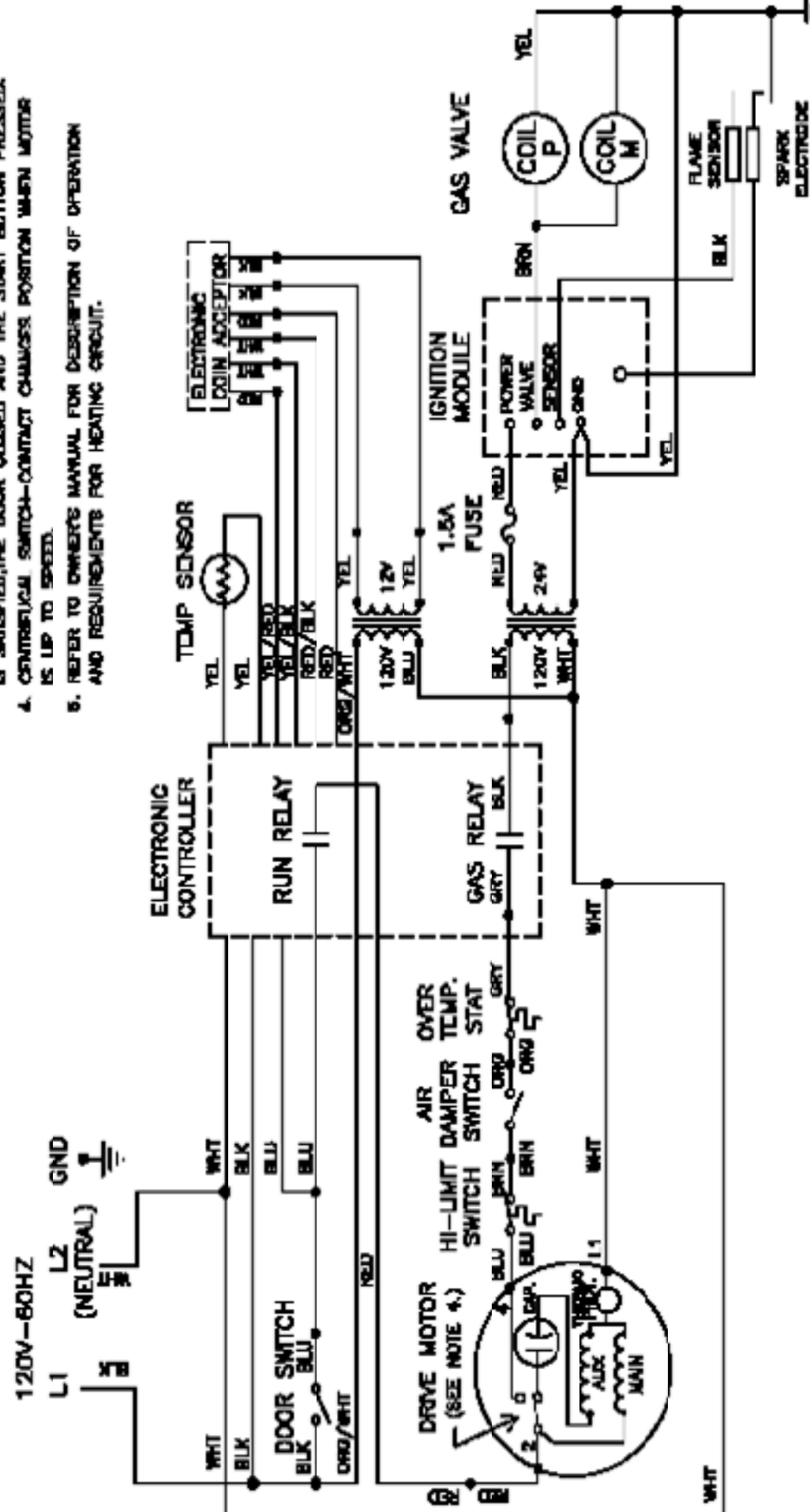

9506-072-002A

SCHEMATIC

DCT\_30KC\_10CP



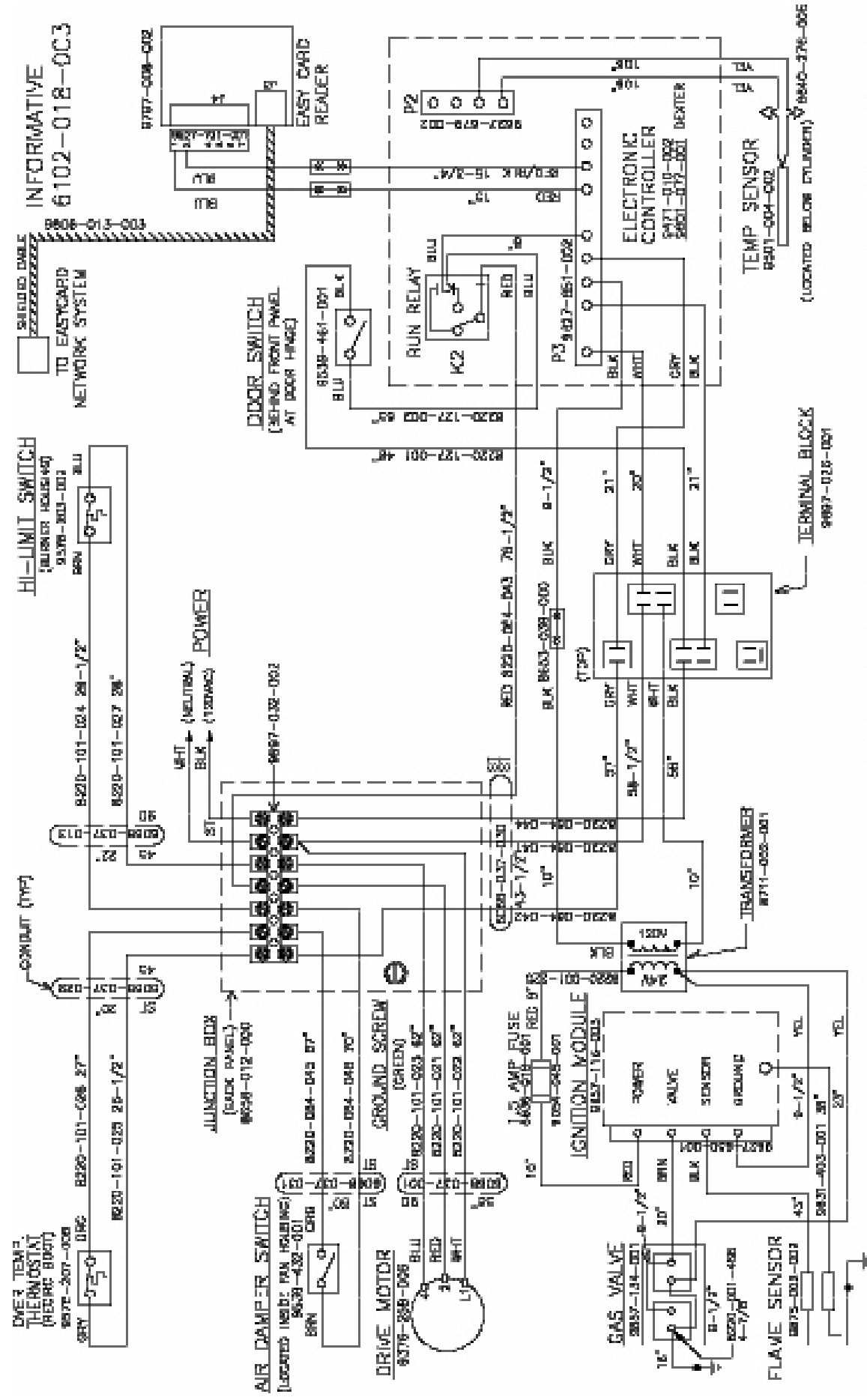

## EC Models (Intergrated EasyCard Ready Parts)

Key	Part Number	Description	Qty
	5192-286-015	Relay .....	1
	8220-001-198	Wireasy- Wht, 46 1/2" .....	1
	8220-001-199	Wireasy- Wht, 53 1/2" .....	1
	8220-001-200	Wireasy- Red, 53 1/2" .....	1
	8220-001-219	Wireasy- Blk, 56" .....	1
	8220-001-220	Wireasy- Red, 56" .....	1
	8220-001-227	Wireasy- Blk, 25 1/2" .....	1
	8220-001-230	Wireasy- Blk/Red, 8 1/2" .....	1
	8220-001-231	Wireasy- Blk/Blu .....	1
	8220-001-282	Wireasy- Red, 20" .....	1
	8220-001-290	Wireasy- Blk .....	1
	8220-001-412	Wireasy- Blu, 20" .....	1
	8220-001-462	Wireasy- Vio, 58" .....	2
	8220-001-478	Wireasy- Grn, 7" .....	1
	8220-001-479	Wireasy- Blu, 45" .....	1
	8220-001-480	Wireasy- Blk, 45" .....	1
	8220-001-530	Wireasy- Blk, 67" .....	1
	8220-001-531	Wireasy- Wht, 12"-4" .....	1
	8220-034-001	Wireasy-Brn,67" .....	1
	8220-034-002	Wireasy-Blu,461/2" .....	1
	8220-062-002	Wireasy- Blk, 11" .....	2
	8220-063-004	Wireasy- Blk, 48" .....	1
	8220-065-006	Wireasy- Blk/Red, 11" .....	1
	8220-065-007	Wireasy- Blk/Blu, 11" .....	1
	8220-068-002	Wireasy- Blk/Red, 7" .....	1
	8220-068-003	Wireasy- Blk/Blu, 5" .....	1
	8220-088-001	Wireasy- Wht, 8" .....	1
	8220-088-002	Wireasy- Blk, 5" .....	1
	8220-088-003	Wireasy- Red, 8" .....	2
	8220-097-001	Wireasy- JUmper, Brn .....	1
	8220-098-003	Wireasy- Jumper, Yel .....	1
	8220-101-001	Wireasy- Gry,251/2" .....	1
	8220-101-014	Wireasy- Vio,42" .....	1
	8220-101-016	Wireasy- Brn,411/2" .....	1
	8507-230-003	Instructions-Transform Connect .....	1
	8507-349-001	Instruction-Switches, Electacpt .....	1
	8514-003-012	Booklet-Owners 30# Dryers 9/07 .....	1
	8615-104-040	Reducer-1/2x3/4 .....	1
	8640-276-003	Nut-Wireconn, #73b, Org .....	10
	8640-424-002	Nut-Hexelasticstop, #4-40 .....	3
	8711-008-002	Transformer-Control .....	1
	9000-043-001	Adapter-3/4usto3/4iso .....	1
	9021-015-002	Acceptor-CoiN, Electronic (109) .....	1
	9029-091-001	Bracket-Control Box .....	1
	9074-263-002	Cover-Ignition Control Box .....	1
	9183-030-001	Filter-Line,Emi .....	1
	9208-039-001	Guard-Drive .....	1
	9248-022-002	Hook-Stype .....	1
	9376-259-008	Motor-Dryer,A.O.Smith (30#) .....	1
	9381-009-005	Manifold Assembly-(2) Port .....	1
	9452-671-001	Plate-Bracket Extender .....	1
	9452-724-001	Plate-Mounting,Computer Control .....	1
	9453-169-009	Pulley-Drive, Machined .....	1
	9454-696-001	Panel-Shield, Motor, Lh .....	1

9454-697-001	Panel-Shield ,Motor, Rh .....	1
9471-011-002	Printed Circuit BOard Assembly .....	1
9506-204-001	Wiring Label- Schematic .....	1
9506-204-002	Wiring Label- Schematic .....	1
9506-205-001	Wiring Label-Diagram .....	1
9506-205-002	Wiring Label-Diagram .....	1
9539-461-007	Switch-Micro .....	1
9545-008-027	Screw-HxwsrhdsLtd, #10-32 Ttx 1/2 .....	1
9627-651-003	Wiring Harness- Electronic Cntrl .....	1
9631-382-002	Wireasy-Gry, 45 1/2" .....	1
9631-403-005	Wireasy-High Voltage .....	1
9732-162-001	Kit-Honeywellvr 86 Valve Flange .....	2
9791-001-002	Adapter Assembly- Gas Inlet .....	1
9804-021-001	Shield Assembly- Motor .....	1
9807-080-001	Box Assembly- Control .....	1
9857-132-004	Control Assembly- Gas .....	1
9857-140-001	Control Assembly- Fenwal .....	1
9857-166-001	Control Assembly .....	1
9897-036-001	Terminal Block Assembly- Power .....	1
9982-334-002	Plate Assembly - Controls Mntng(Cmptr) .....	1

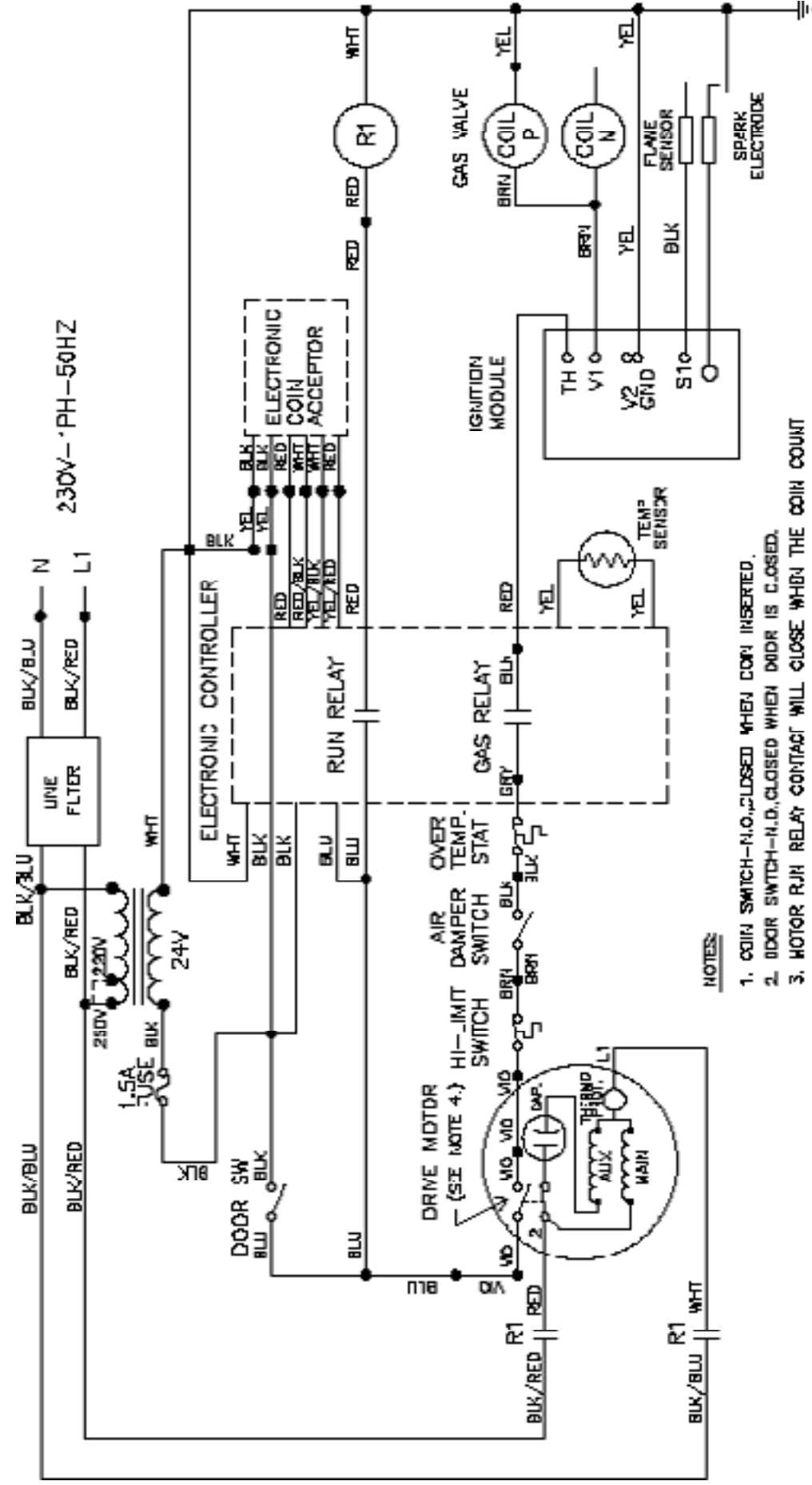

**NOTES:**

1. COIN SWITCH--N.O.,CLOSED WHEN COIN INSERTED.
2. DOOR SWITCH--N.O.,CLOSED WHEN DOOR IS CLOSED.
3. MOTOR RUN RELAY CONTACT WILL CLOSE WHEN THE COIN COUNT IS SATISFIED,THE DOOR CLOSED AND THE START BUTTON PRESSED.
4. CENTRIFUGAL SWITCH--CONTACTS CHANGE POSITION WHEN MOTOR S UP TO SPEED.
5. REFER TO OWNER'S MANUAL FOR DESCRIPTION OF OPERATION AND REQUIREMENTS FOR HEATING CIRCUIT.

9505-204-002A

**SCHEMATIC**

DCT\_30KC\_59CR

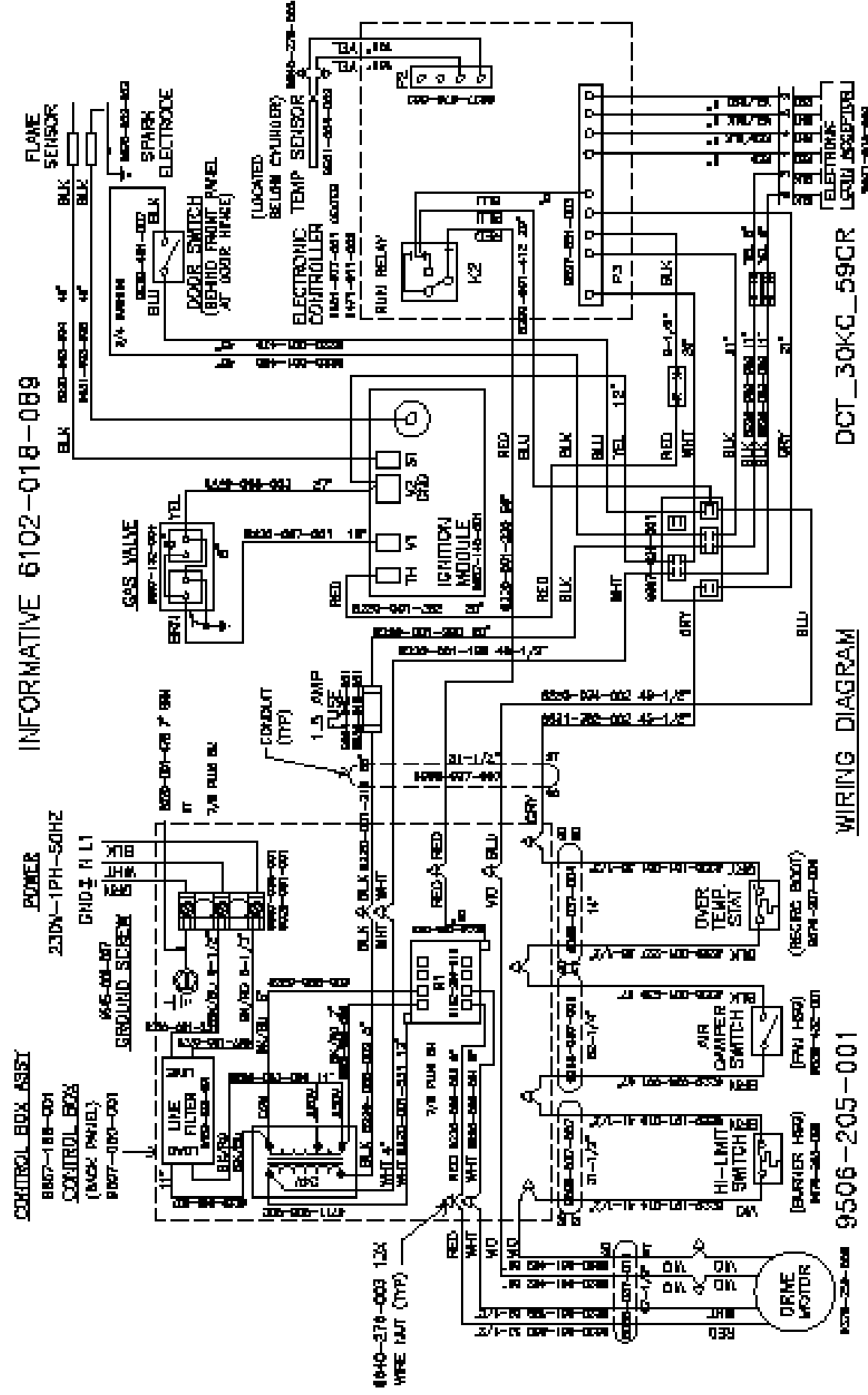

9506-205-001

**WIRING DIAGRAM**

DCT\_30KC\_59CR

## 21CR Gas Heated Parts

Key	Part Number	Description	Qty
	5192-288-001	Relay .....	1
	8502-698-001	Label-Aussie warning .....	1
	8502-699-001	Label-Aust gas approval badge .....	1
	8502-725-001	Label-Instruct/Warn, Electr coin .....	1
	8502-730-001	Label-Warning, Elec coin acceptor .....	1
	8507-230-003	Instructions-Transform connect .....	1
	8507-298-001	Instructions-Aussie addendum .....	1
	8640-276-003	Nut-Wireconn,#73b,Org .....	13
	8711-008-002	Transformer-Control .....	1
	9021-015-002	Acceptor-Coin, Electronic(109) .....	1
	9074-263-001	Cover-Ignition control box .....	1
	9183-030-001	Filter-Line, Emi .....	1
	9208-039-001	Guard-Drive .....	1
	9248-022-002	Hook-Stype .....	1
	9376-259-008	Motor-Dryer,A.O.Smith(30#) .....	1
	9381-009-005	Manifold assembly-(2)Port .....	1
	9435-016-001	Overlay-Trim, Lwr serv door,30# .....	1
	9452-671-001	Plate-Bracket extender .....	1
	9452-724-001	Plate-Mounting, Computer control .....	1
	9453-169-009	Pulley-Drive, Machined .....	1
	9454-644-001	Panel-Control box, Top .....	2
	9454-696-001	Panel-Shield, Motor, Lh .....	1
	9454-697-001	Panel-Shield, Motor, Rh .....	1
	9456-041-006	Plug-Plastic,7/8" .....	7
	9471-011-002	Printed circuit board assembly .....	1
	9506-074-002	Wiringlabel-Schematic .....	1
	9506-075-002	Wiringlabel-Diagram .....	1
	9578-087-001	Trim-Door, Lower service .....	1
	9627-651-003	Wiring harness-Electronic control .....	1
	9631-381-018	Wire assembly-Red,7" .....	1
	9631-382-002	Wire assembly-Gry,45 1/2" .....	1
	9732-162-001	Kit-Honey wellvr 86 valve flange .....	2
	9804-021-001	Shield assembly-Motor .....	1
	9807-080-001	Box asy- Control .....	1
	9857-129-001	Controls asy-Ignition, Johnson .....	1
	9857-131-001	Control asy .....	1
	9857-132-004	Control assembly-Gas .....	1
	9982-334-001	Plateasy-Controls mntng(Cmptr) .....	1
	9982-334-002	Plateasy-Controls mntng(Cmptr) .....	1
	8220-001-198	Wire assembly-Wht,46 1/2" .....	1
	8220-001-199	Wire assembly-Wht,53 1/2" .....	1
	8220-001-200	Wire assembly-Red,53 1/2" .....	1
	8220-001-219	Wire assembly-Blk,56" .....	1
	8220-001-220	Wire assembly-Red,56" .....	1
	8220-001-221	Wire assembly-Blk,45" .....	1
	8220-001-222	Wire assembly-Blu,45" .....	1
	8220-001-227	Wire assembly-Blk,25 1/2" .....	1
	8220-001-282	Wire assembly-Red,20" .....	1
	8220-001-332	Wire assembly-Blk .....	1
	8220-001-333	Wire assembly-Wht .....	1
	8220-001-411	Wire assembly-Red,9" .....	2
	8220-001-412	Wire assembly-Blu,20" .....	1
	8220-001-530	Wire assembly-Blk,67" .....	1
	8220-034-001	Wire assembly-Brn,67" .....	1
	8220-034-002	Wire assembly-Blu,46 1/2" .....	1
	8220-057-020	Wire assembly-Blu,54" .....	2
	8220-062-002	Wire assembly-Blk,11" .....	2

8220-062-024	Wire assembly-Wht,19" .....	1
8220-063-004	Wire assembly-Blk,48" .....	1
8220-064-025	Wire assembly-Wht,9" .....	2
8220-088-013	Wire assembly-Blk,6" .....	1
8220-090-002	Wire assembly-Jumper,Brn .....	1
8220-098-001	Wire assembly-Jumper,Yel .....	1
8220-100-002	Wire assembly-Jumper .....	1
8220-101-001	Wire assembly-Gry,25 1/2" .....	1
8220-101-003	Wire assembly-Blu,41 1/2" .....	1
8220-101-016	Wire assembly-Brn,41 1/2" .....	1
8220-107-001	Wire assembly-Jumper,Wht .....	2

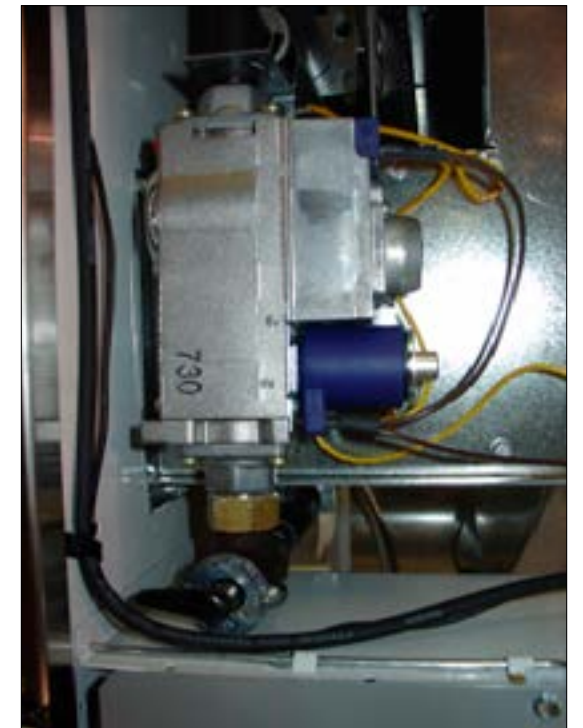
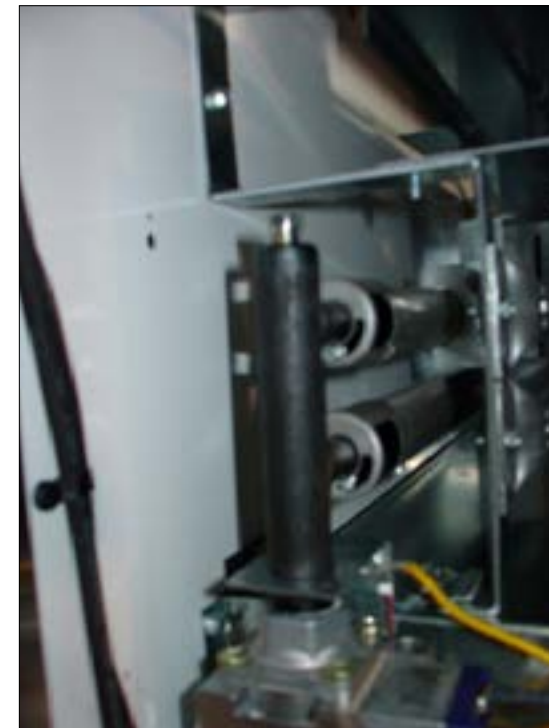
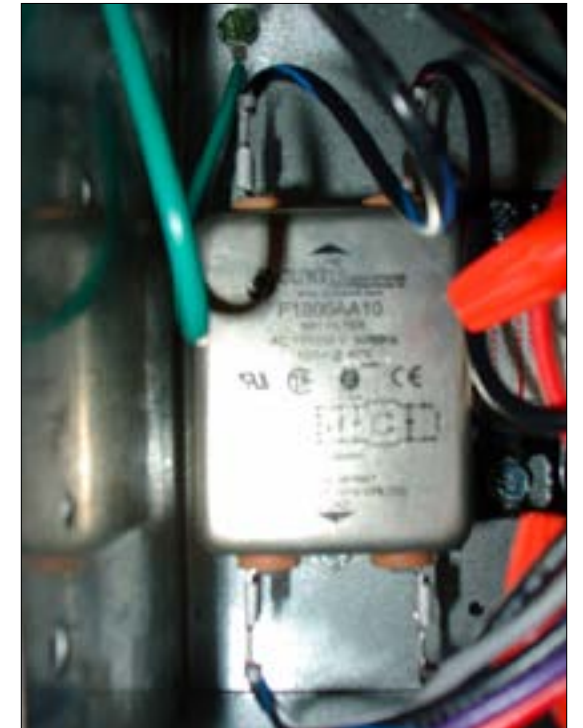



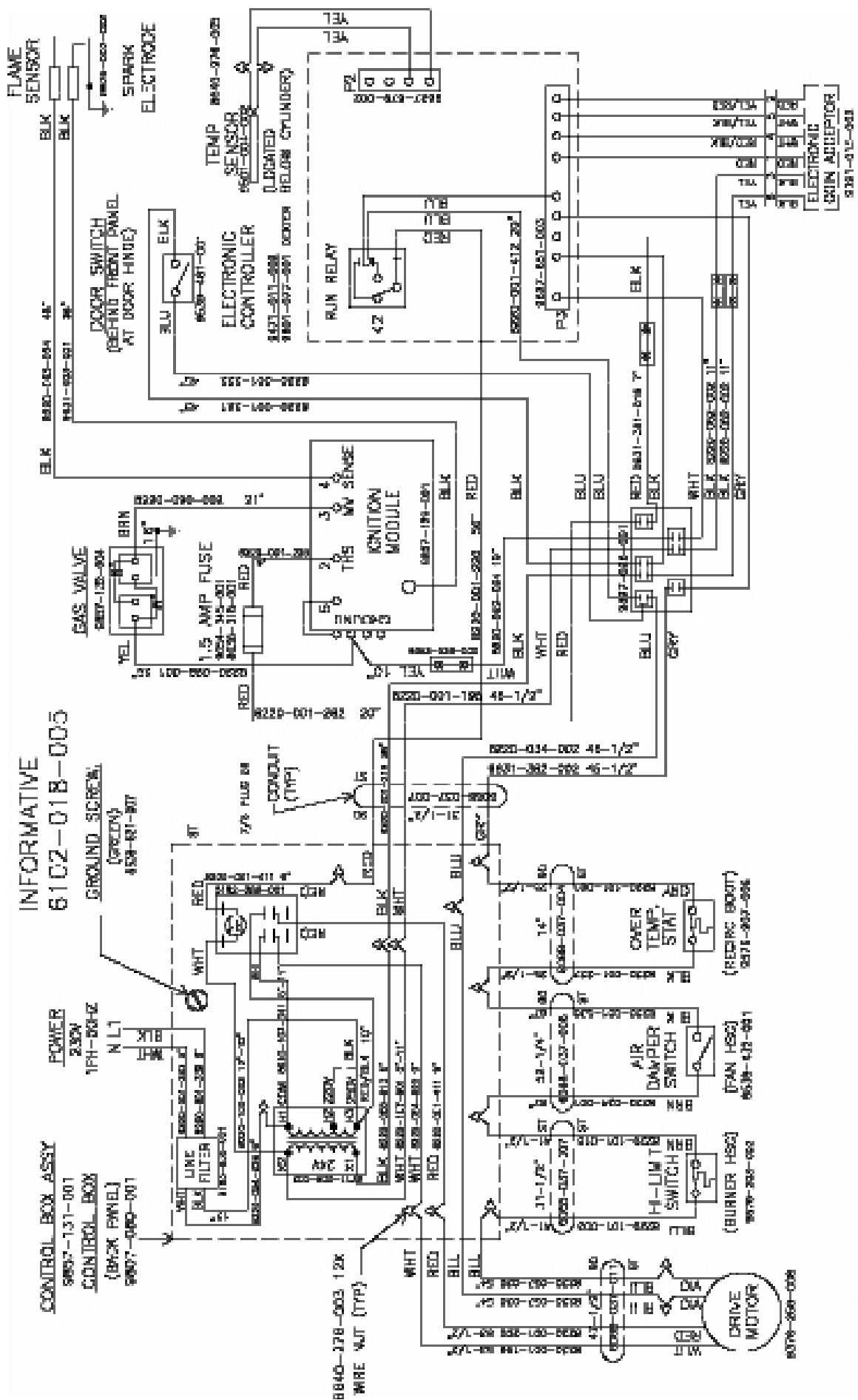

DCT\_30KC\_21CR\_50HZ\_AL

WIRING DIAGRAM

9506-075-0C2

### 16FE Electric Heated Parts List

Key	Part Number	Description	Qty
	5192-294-001	Relay-125 amp (Resistive) Contact.....	1
	5198-213-004	Circuit breaker-3 pole.....	2
	8220-057-004	Wire assembly-Brn,30".....	1
	8220-057-007	Wire assembly-Wht/Blk,45".....	1
	8220-057-008	Wire assembly-Blk,45".....	1
	8220-057-014	Wire assembly-Blk,8".....	3
	8220-057-015	Wire assembly-Blk,8".....	6
	8220-057-019	Wire assembly-Wht,8".....	1
	8220-061-008	Wire assembly-Blk,36".....	4
	8220-061-010	Wire assembly-Blk,48".....	2
	8220-064-021	Wire assembly-Blk/Wht,90".....	1
	8220-095-025	Wire assembly-Red,31".....	1
	8220-101-002	Wire assembly-Blk,64".....	1
	8220-101-005	Wire assembly-Gry,64".....	1
	8220-101-015	Wire assembly-Brn,30".....	1
	8502-614-004	Label-Warning,High voltage.....	1
	8502-639-001	Label-Warning.....	1
	8502-658-001	Label-Warning,Fire hazard.....	1
	8502-702-001	Label-Warn,Fire hazard (French).....	1
	8502-708-001	Label-Exhaust warning.....	1
	8502-711-001	Label-Warning for 208v.....	1
	8514-106-001	Booklet-Owners, 30# Htd Dryer.....	1
	8639-621-007	Screw-Hx wshr hd,#10-32x1/2,Gm.....	1
	8640-276-003	Nut-Wire conn,#73b,Org.....	1
	8652-134-002	Terminal-Lug, Solderless.....	1
	8653-068-004	Connector-Conduit, 90 degree.....	5
	8653-068-006	Connector-Conduit, 3/8", 45.....	1
	9029-127-001	Bracket-Guard mounting.....	1
	9058-025-001	Bottom-Box, Control.....	1
	9074-288-001	Cover-Plate, Heater.....	1
	9074-289-001	Cover-Box, Control.....	1
	9074-290-001	Cover-Housing, Overtemp thermo.....	1
	9109-108-001	Duct-Thermostat,Over temp.....	1
	9142-039-001	Elbow-90 degree ajd,8".....	2
	9208-053-001	Guard-Front,Cabinet cover.....	1
	9208-058-001	Guard-Rear,Right hand (Cover).....	1
	9208-059-001	Guard-Rear,Left hand (Cover).....	1
	9241-187-001	Housing-Thermostat, Overtemp.....	1
	9295-004-001	Jumper-Formed.....	2
	9295-005-001	Jumper-Straight.....	4
	9377-003-001	Varistor-Coil suppressor.....	1
	9488-010-001	Rail-Din.....	0.396
	9488-010-003	Rail-Din, 43/4".....	1
	9506-176-002	Wiring label-Schematic.....	1
	9506-177-002	Wiring label-Diagram.....	1
	9548-282-001	Support-Wire.....	2
	9870-088-001	Heater-Electric elem, 15kw, 208v.....	2
	9897-037-001	Block-Power, 3 pole.....	1
	9897-038-001	Block-Power, 1 pole.....	1



## 66 FW Electric Heated Parts List

Key	Part Number	Description	Qty
	5192-285-004	Relay .....	1
	5192-288-001	Relay .....	1
	5192-290-002	Relay-Heaters,40amp(240vac) .....	1
	5198-215-002	Circuitbreaker-3pole,415v .....	1
	8220-001-199	Wireasy-Wht,531/2" .....	1
	8220-001-200	Wireasy-Red,531/2" .....	1
	8220-001-221	Wireasy-Blk,45" .....	1
	8220-001-222	Wireasy-Blu,45" .....	1
	8220-001-290	Wireasy-Blk .....	1
	8220-001-411	Wireasy-Red,9" .....	2
	8220-001-412	Wireasy-Blu,20" .....	1
	8220-001-530	Wireasy-Blk,67" .....	1
	8220-034-001	Wireasy-Brn,67" .....	1
	8220-034-002	Wireasy-Blu,461/2" .....	1
	8220-057-004	Wireasy-Brn,30" .....	1
	8220-057-007	Wireasy-Wht/Blk,45" .....	1
	8220-057-008	Wireasy-Blk,45" .....	1
	8220-057-011	Wireasy-Vio,32" .....	1
	8220-057-015	Wireasy-Blk,8" .....	3
	8220-057-019	Wireasy-Wht,8" .....	1
	8220-057-020	Wireasy-Blu,54" .....	2
	8220-057-030	Wireasy-Blk,17" .....	3
	8220-061-008	Wireasy-Blk,36" .....	3
	8220-064-025	Wireasy-Wht,9" .....	1
	8220-064-051	Wireasy-Red/Blk,62" .....	1
	8220-078-008	Wireasy-Blk,9" .....	2
	8220-078-011	Wireasy-Wht,45" .....	1
	8220-078-012	Wireasy-Red,45" .....	1
	8220-088-013	Wireasy-Blk,6" .....	1
	8220-101-002	Wireasy-Blk,64" .....	1
	8220-101-005	Wireasy-Gry,64" .....	1
	8220-101-014	Wireasy-Vio,42" .....	1
	8220-101-015	Wireasy-Brn,30" .....	1
	8220-107-001	Wireasy-Jumper,Wht .....	2
	8220-107-002	Wireasy-Jumper,Blk .....	1
	8502-614-004	Label-Warning,Highvoltage .....	1
	8502-639-001	Label-Warning .....	1
	8502-658-001	Label-Warning,Firehazard .....	1
	8502-698-001	Label-Aussiewarning .....	1
	8502-708-001	Label-Exhaustwarning .....	1
	8507-230-003	Instructions-Transformconnect .....	1
	8507-298-001	Instructions-Aussieaddendum .....	1
	8636-018-004	Fuse-2.5a .....	1
	8652-134-002	Terminal-Lug,Solderless .....	1
	8653-039-000	Connector-WiRe,Inline,1/4" .....	1
	8711-008-002	Transformer-Control .....	1
	9021-002-015	Acceptor-Coin,Complete .....	1
	9029-127-001	Bracket-Guardmounting .....	1
	9058-025-001	Bottom-Box,Control .....	1
	9074-263-001	Cover-Ignitioncontrolbox .....	1
	9074-288-001	Cover-Plate,Heater .....	1
	9074-289-001	Cover-Box,Control .....	1
	9074-290-001	Cover-Housing,Overtmpthermo .....	1
	9109-108-001	Duct-Thermostat,Overtmp .....	1
	9142-039-001	Elbow-90 degree, 8" .....	2

9208-039-001	Guard-Drive .....	1
9208-053-001	Guard-Front,Cabinetcover .....	1
9208-058-001	Guard-Rear,Righthand(Cover) .....	1
9208-059-001	Guard-Rear,Lefthand(Cover) .....	1
9210-117-001	Gusset-Box,Control .....	1
9241-187-001	Housing-Thermostat,Overtmp .....	1
9248-022-002	Hook-Style .....	1
9295-006-001	Jumper-Straight,3hole .....	1
9376-259-008	Motor-Dryer,A.O.Smith(30#) .....	1
9377-003-002	Varistor-Coilsuppressor .....	1
9435-016-001	Overlay-Trim,Lwrservdoor,30# .....	1
9452-668-003	Plate-Controls,Mounting(Cmptr) .....	1
9452-741-001	Plate-Replacement,Heater .....	1
9453-169-001	Pulley-Drive-Casting-Manual .....	1
9453-169-009	Pulley-Drive,Machined .....	1
9454-644-001	Panel-ControlbOx,Top .....	2
9454-696-001	Panel-Shield,Motor,Lh .....	1
9454-697-001	Panel-Shield,Motor,Rh .....	1
9456-041-006	Plug-Plastic,7/8" .....	9
9471-011-002	Printedcircuitboardassembly .....	1
9488-010-001	Rail-Din .....	0.396
9488-010-003	Rail-Din,43/4" .....	1
9506-206-001	Wiringlabel-Schematic .....	1
9506-206-002	Wiringlabel-Schematic .....	1
9506-207-001	Wiringlabel-Diagram .....	1
9506-207-002	Wiringlabel-Diagram .....	1
9544-041-002	Strap-Beadedtie .....	1
9548-282-001	Support-Wire .....	1
9578-087-001	Trim-Door,Lowervservice .....	1
9804-021-001	Shieldassembly-Motor .....	1
9857-163-001	Controlasy .....	1
9870-088-002	Heater-Electricelem,15kw,240v .....	1
9897-037-001	Block-Power,3pole .....	1
9897-038-001	Block-Power,1pole .....	1
9982-305-005	Plateasy-Controls,Mntg(Cmptr) .....	1
9982-305-006	Plateasy-Controls,Mntg(Cmptr) .....	1



## Section 7: Maintenance

### Preventative Maintenance

#### Daily

**Step 1:** Clean the lint screen free of lint and other debris. Use a soft brush and Hot water if necessary.

**Step 2:** Check the lint screen for tears. Replace if necessary.

**Step 3:** Clean lint from the lint screen compartment.

**Step 4:** Inspect felt seal on lint screen assembly, replace if needed.

#### Monthly

**Step 1:** Remove lint accumulation from the end bells of the motor.

**Step 2:** Remove lint accumulation from front control area.

**Step 3:** Remove lint and dirt accumulation from the top of the dryer and all areas above, below, and around the burners and burner housing. Failure to keep this portion of the dryer clean can lead to a build-up of lint creating a fire hazard.

**Step 4:** Remove and clean coin acceptors. (Vended Models Only)

#### Quarterly

**Step 1:** Check the belts for looseness, wear, or fraying.

**Step 2:** Inspect the gasket of the door glass for excessive wear.

**Step 3:** Check tightness of all fasteners holding parts to support channel.

**Step 4:** Check tightness of all set screws.

**Step 5:** Remove the air flow switch assembly and check the tumbler thru-bolts for tightness.

**Step 6:** Apply a few drops of oil to pivot pins and the tension arms where in contact with each other.

#### Semi-Annually

**Step 1:** Remove and clean the main burners.

**Step 2:** Remove all orifices and examine for dirt and hole obstruction.

**Step 3:** Remove all lint accumulation. Remove the front panel and the lint screen housing and remove lint accumulation.

#### Annually

**Step 1:** Check the intermediate pulley bearings for wear.

**Step 2:** Check and remove any lint accumulation from the exhaust system including recirculation chambers if applicable.

**Step 3:** Grease the bearings and the shaft of the intermediate pulley. Use an Alemite grease gun and Molykote BR2-S grease. (Where applicable)