



DEXTER[®]
LAUNDRY

**USE THE BLUE TABS LOCATED ON THE
RIGHT AND LEFT SIDES OF THE FOLLOWING
DOCUMENT TO ADVANCE TO EACH SECTION.**

Kits, Assemblies, & Common Parts

Description	T120
Kit - 220v Motor Conversion	9732-304-001
Kit - A to C series Conversion, Black, 120v	9732-307-002
Kit - A to C series Conversion, Blue, 120v	9732-307-001
Kit, Optional Replacement for Round Switch 9539-492-001	9732-351-001
Temperature Probe	9501-004-002
Control	9732-249-001
Ignition Control Box	9857-182-001
Electrode Assembly, Ignition	9875-002-003
Thermostat, Hi-Limit	9576-203-002
Thermostat, Overtemp	9576-207-006
Motor Run Relay	5192-299-002
Transformer	8711-007-002
Lint Screen	9822-033-001
Air Flow Switch	9539-461-009
Front Panel Assy (Wht) Round Switch	9989-546-001
Front Panel Assy (Wht) Square Switch	9444-007-003
Motor Belt	9040-076-008
Tumbler Belt	9040-076-005
Spider/Trunnion	9568-016-001
Door Handle	9244-082-001



Section 5: Dryer Parts Data

DN0120NC-10EB1R
Before Serial D1.19254.036

Dryer Cabinet Front Panel

Key	Description	T-120	
*	Loading Door Complete Wht/Brushed SS/Blk	9960-305-003	1
1	Door Assy, Loading (Ring only) Brushed SS	9960-284-002	1
2	Plate Assy, Hinge (Wht)	9982-368-003	1
*	Cover-Hinge Back, Black	9074-340-002	1
*	Screw-10Bx3/8, Black	9545-008-010	2
*	Screw Hinge to Door	9545-012-015	4
*	Nut, Hinge to Door	8640-413-002	4
3	Glass, Door	9212-002-004	1
4	Gasket, Door Glass (Black)	9206-413-002	1
*	Support Door Glass	9545-117-000	2
5	Gasket, Door Outer Rim (Black)	9206-420-005	1
6	Handle, Loading Door	9244-082-001	1
*	Screw, Handle	9545-018-017	2
7	Stud Door Catch 7/8"	9531-033-003	1
8	Nut-Hex, #10-32	8640-413-001	1
9	Nut, Acorn	8640-413-003	1
*	Catch, Loading Door	9086-015-002	2
*	Rivet	9491-009-004	2
10	Strap, Hinge (Black)	9966-014-002	1
*	Chanel Assy-Front Panel	9947-024-001	1
*	Screw-Phillips, 10-32x1/2 Chrome	9545-012-028	4
*	Screw-Phillips-Counter sink, 10-32x1/2 Chrome	9545-012-003	2
11	Screw-Special, Hinge to Door	9545-052-001	1
*	Nut-Allen, 1/4-20	8640-439-001	1
12	Washer-Fiber/Plastic	8641-436-003	1
13	Front Panel Assy (Wht) Round Switch	9989-546-001	1
13	Front Panel Assy (Wht) Square Switch	9444-007-003	1
14	Screw-Phillips, 10Bx1 3/4	9545-008-014	10
15	Washer-Finish	8641-585-001	10
*	Nut-Spring	8640-399-001	10
16	Screw-Torx, 10AB x 3/4", White "T-20"	9545-008-035	8
*	Insulation-Front Panel	9277-060-001	1
17	Label-Warning	8502-753-001	1
18	Plug-Front Panel, Optional Door Switch Location (Round)	9456-050-001	1
18	Plug-Front Panel, Optional Door Switch Location (Square)	9456-055-001	1
*	Switch-Door (Round)	9539-492-001	1
*	Switch-Door (Square)	9539-501-001	1
*	Wire-Assy-Blk, 23"	8220-063-028	1
*	Wire-Assy-Red, 23"	8220-063-029	1
19	Plug, 1/4", Locking	9456-051-001	6
*	Plug-2"	9456-041-009	1
20	Switch Assembly-Membrane	9801-103-001	1
21	Box-Control	9041-107-002	1
*	Cabinet Touch Up Paint (White)	9472-001-013	1

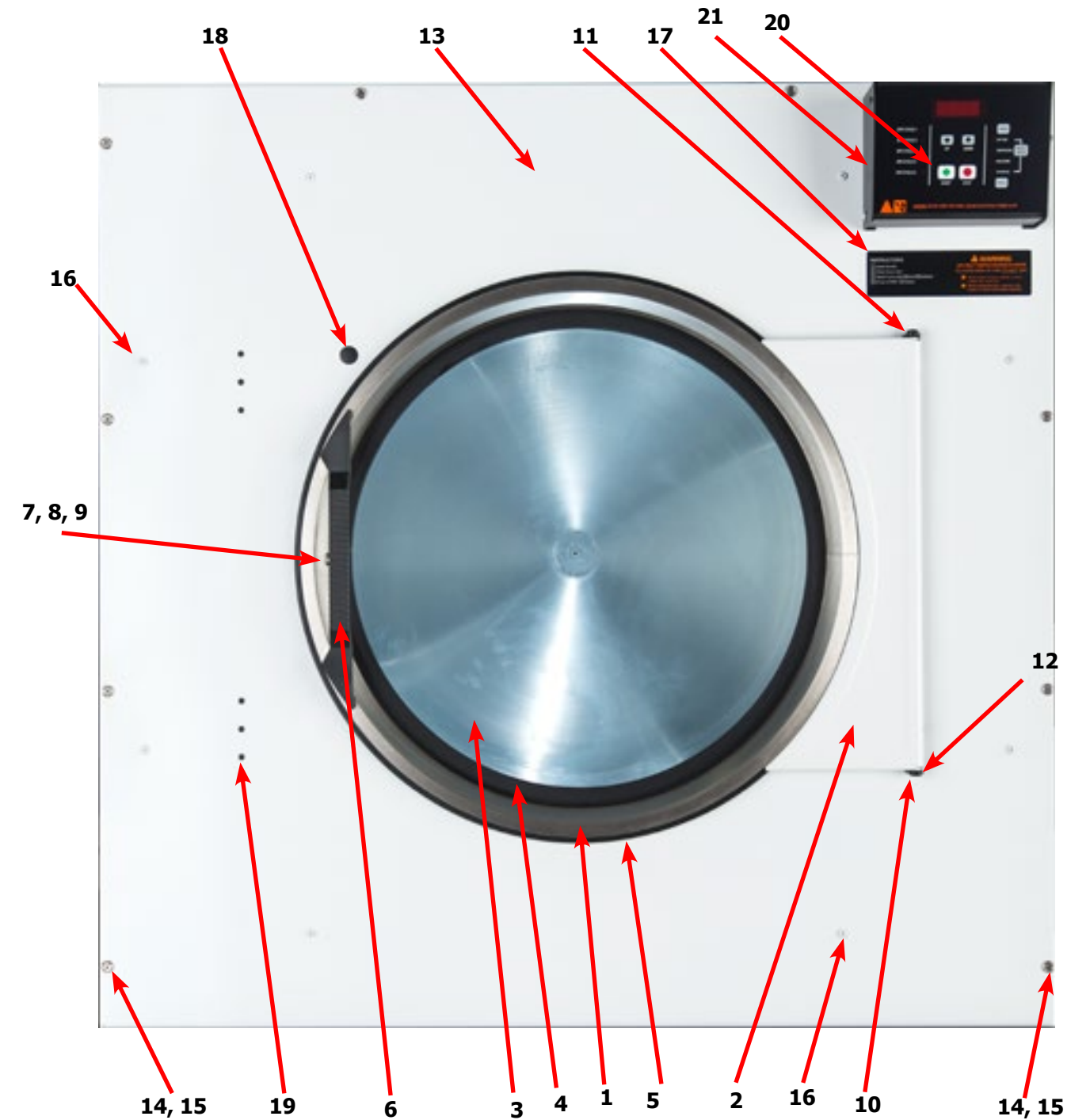

Dryer Cabinet Group Continued

Key	Description	T-120	QTY
1	Nameplate - Dexter Dryer Black	9412-196-001	1
2	Door Assy-Upper, OPL (Wht)	9454-884-002	1
3	Screw-Phillips, 10Bx1 3/4	9545-008-014	4
4	Washer-Finish	8641-585-001	4
*	Nut-Spring	8640-399-001	4
5	Box-Control Front, Black	9041-107-002	1
6	Screw-5/16, 10ABx3/8	9545-008-024	4
7	Screw-10-32 x 1/2, Chrome	9545-012-003	2
8	Plate Assembly-Meter, Black	9982-379-002	1
9	Nut-Elastic Stop, #10-32	8640-413-004	2
10	Spacer-#6 x 1/2	9538-157-016	4
11	Kit-OPL Reversing, PCB-Controler	9732-249-001	1
12	Nut, #6-32	8640-411-001	3
13	Wire Assy-GRN, 12"	8220-060-001	1
14	Nut, #6-32	8641-411-003	1
15	Screw, #10-32 x1/2 Green	9545-008-027	1
16	Lock Washer #10	8641-582-006	1
17	Fuse, .600MA/250V	8636-024-001	1
18	Membrane Switch	9801-103-001	1
19	Screw Torx-6BSD x 1/2, BLK, "T10"	9545-031-009	2
20	Harness-Control	9627-770-002	1
21	Harness-Temp Probe	9627-679-002	1
22	Plug-2"	9456-041-009	1
23	Label-Warning	8502-753-001	1

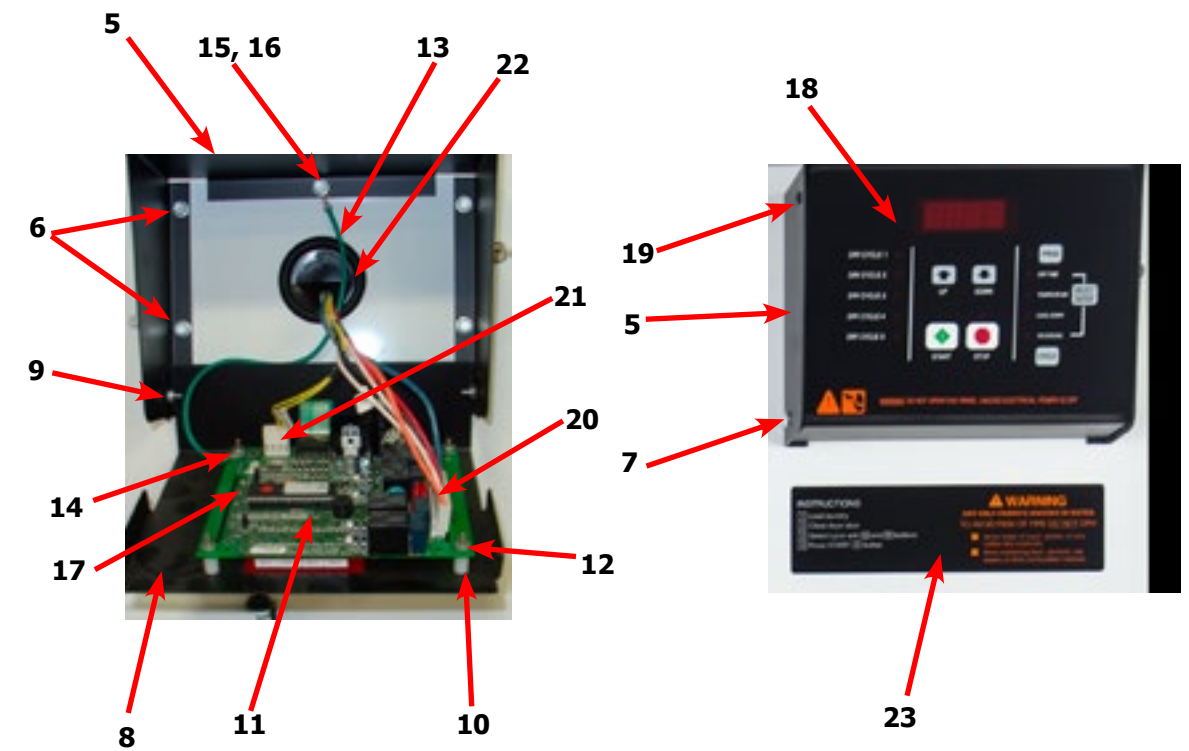

Dryer Cabinet Group Continued

Key	Description	T-120	QTY
*	Assembly-Door-Lower Service, OPL, Wht (Number 1 thru 14)	9960-307-001	1
1	Door-Lower Service, OPL, Wht	9108-132-002	1
2	Handle-Door, Lower Service, Black	9244-090-002	1
*	Screw-Phillips, 10Bx3/8, Black	9545-008-010	5
3	Handle,Turn-Door, Lower Service OPL	9244-084-002	2
4	Trim-Lower Kick, Black	9578-100-002	1
5	Screw-Phillips, 10Bx3/8, Black	9545-008-010	5
6	Bracket, Lower Service, (Hinge Bracket)	9029-233-001	2
7	Rivet, 1/8 Low Profile	9491-009-004	4
8	Nut, Elastic Stop, 10-32 UNF	8640-413-007	2
9	Arm, Lower Service, Right	9001-064-003	1
10	Screw. 10-32 x 1/2"	9545-012-003	1
11	Arm, Lower Service, Left	9001-064-004	1
*	Screw. 10-32 x 1/2"	9545-012-003	1
12	Insulation	9277-059-001	1
13	Bracket-Door Switch	9029-226-001	2
14	Rivet, 1/8 Low Profile	9491-009-004	4
15	Switch-Door (Round)	9539-492-001	2
*	Switch-Door (Square)	9539-501-001	1
*	Kit, Optional Replacement for Round Switch 9539-492-001	9732-351-001	1
16	Hinge-Door, Lower	9243-083-002	1
17	Screw-5/16, 10ABx3/8	9545-008-024	5
18	Screen Assy, Lint	9822-033-001	1
*	Footing Foot	9188-016-001	4

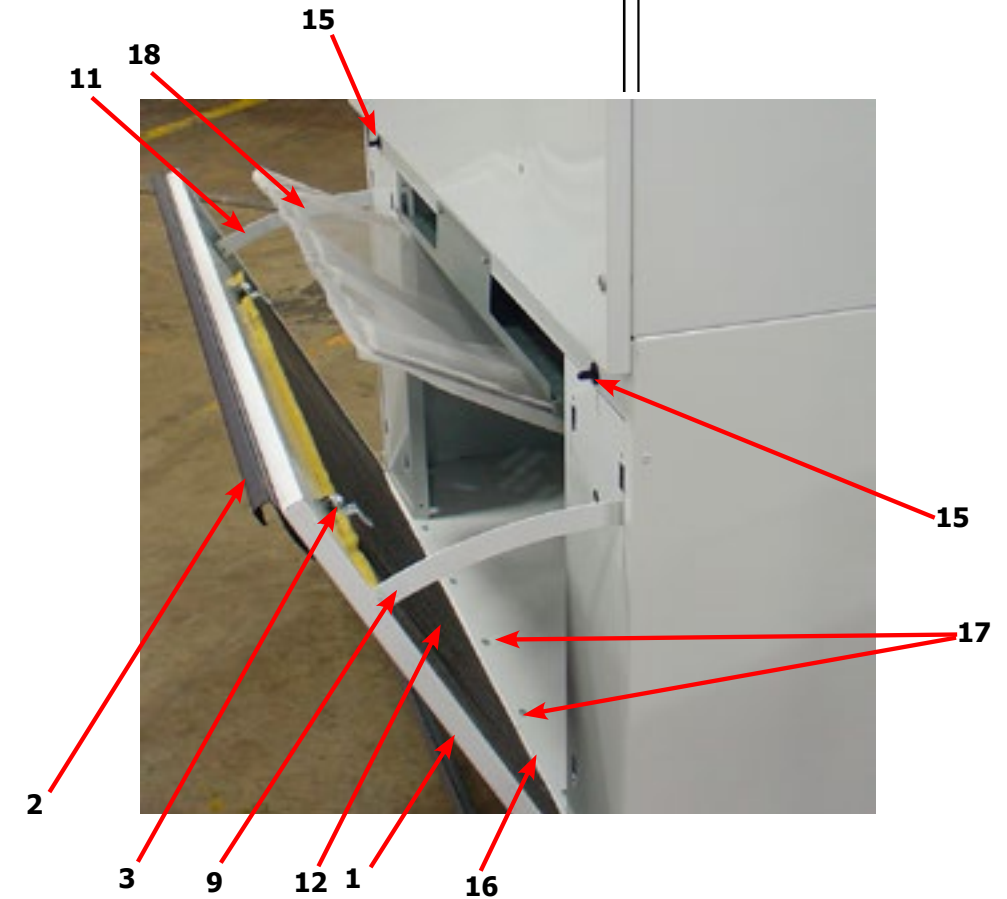
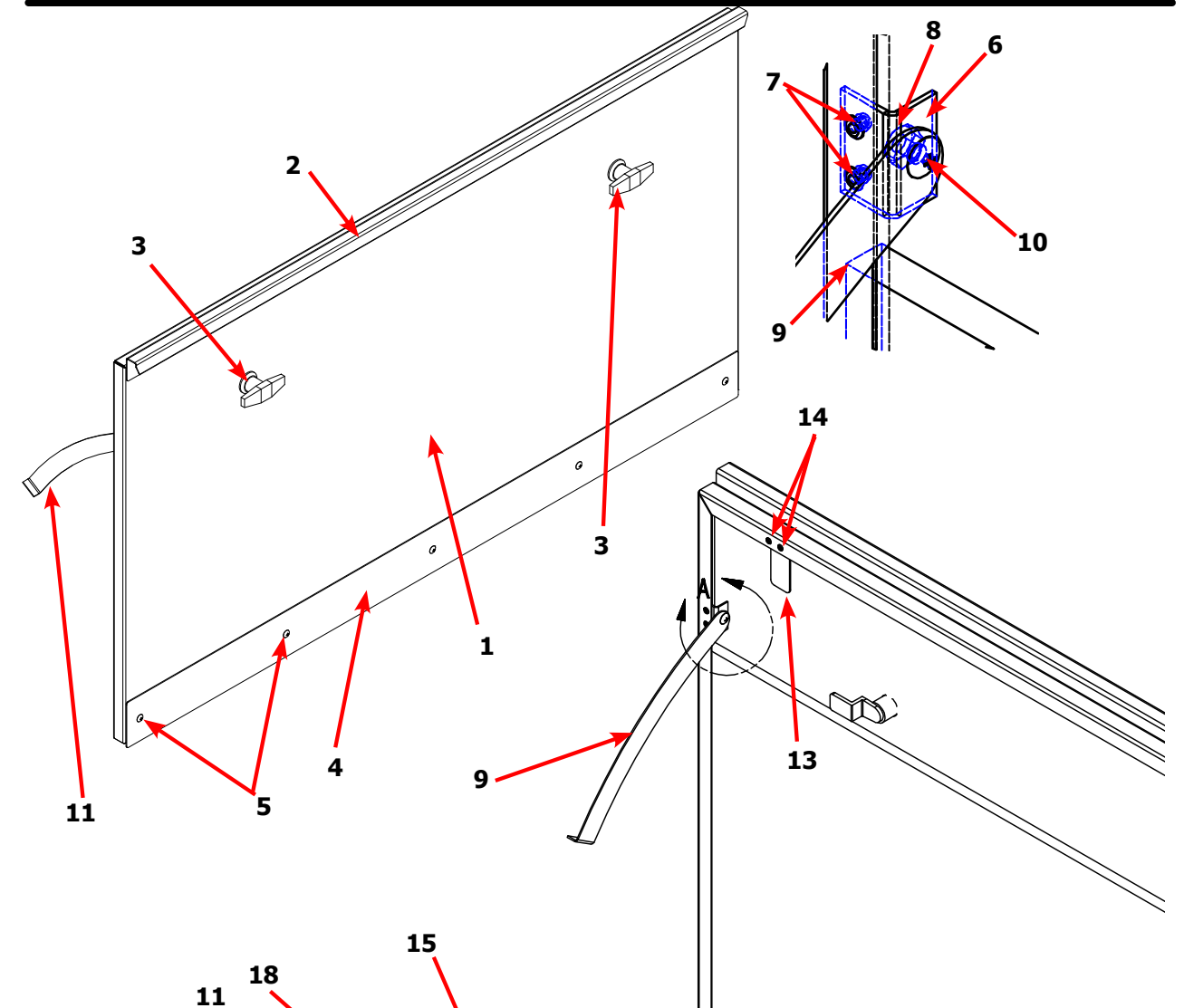

Dryer Cabinet Group Continued

Key	Description	T-120	QTY
1	Panel Assy.-Upper Right	9989-549-002	1
*	Screw, 5/16- 10ABx3/8	9545-008-024	2
2	Insulation-Right Upper, Burner Area	9277-041-002	1
3	Panel Assy.-Upper Left	9989-550-002	1
*	Screw, 5/16- 10ABx3/8	9545-008-024	2
4	Insulation Tumbler Area, Right (Front & Back)	9277-051-005	2
4	Insulation Tumbler Area, Right (Center)	9277-051-006	1
5	Insulation Tumbler Area, Left (Front & Back)	9277-051-005	2
5	Insulation Tumbler Area, Left (Center)	9277-051-006	1
6	Switch-Door (Round)	9539-492-001	2
*	Switch-Door (Square)	9539-501-001	
*	Screen Assy, Lint	9822-033-001	1
*	Lint Hood Assembly	9834-011-001	1
7	Lint Hood, Top & Sides	9240-047-001	1
8	Lint Hood, Bottom	9058-028-001	1
9	Lint Hood, Angle	9003-333-001	1
10	Screw, 5/16- 10ABx3/8	9545-008-024	21
11	Hinge-Door, Lower	9243-083-002	1
*	Screw-5/16, 10ABx3/8	9545-008-024	5
12	Impeller, w/set screws	9278-041-001	1
13	Harness -Temp Probe	9627-679-002	1
14	Wire Nut, #71B	8640-276-005	2
15	Temp Probe	9501-004-002	1
16	Screw-Phillips, 8Bx1/4	9545-045-005	1
17	Bracket, Temp Probe	9029-111-001	1
18	Screw, 8AB x 3/8	9545-045-008	2
19	Trim-Edge, Lint Hood	9578-092-003	2

120Lb. Temp Probe

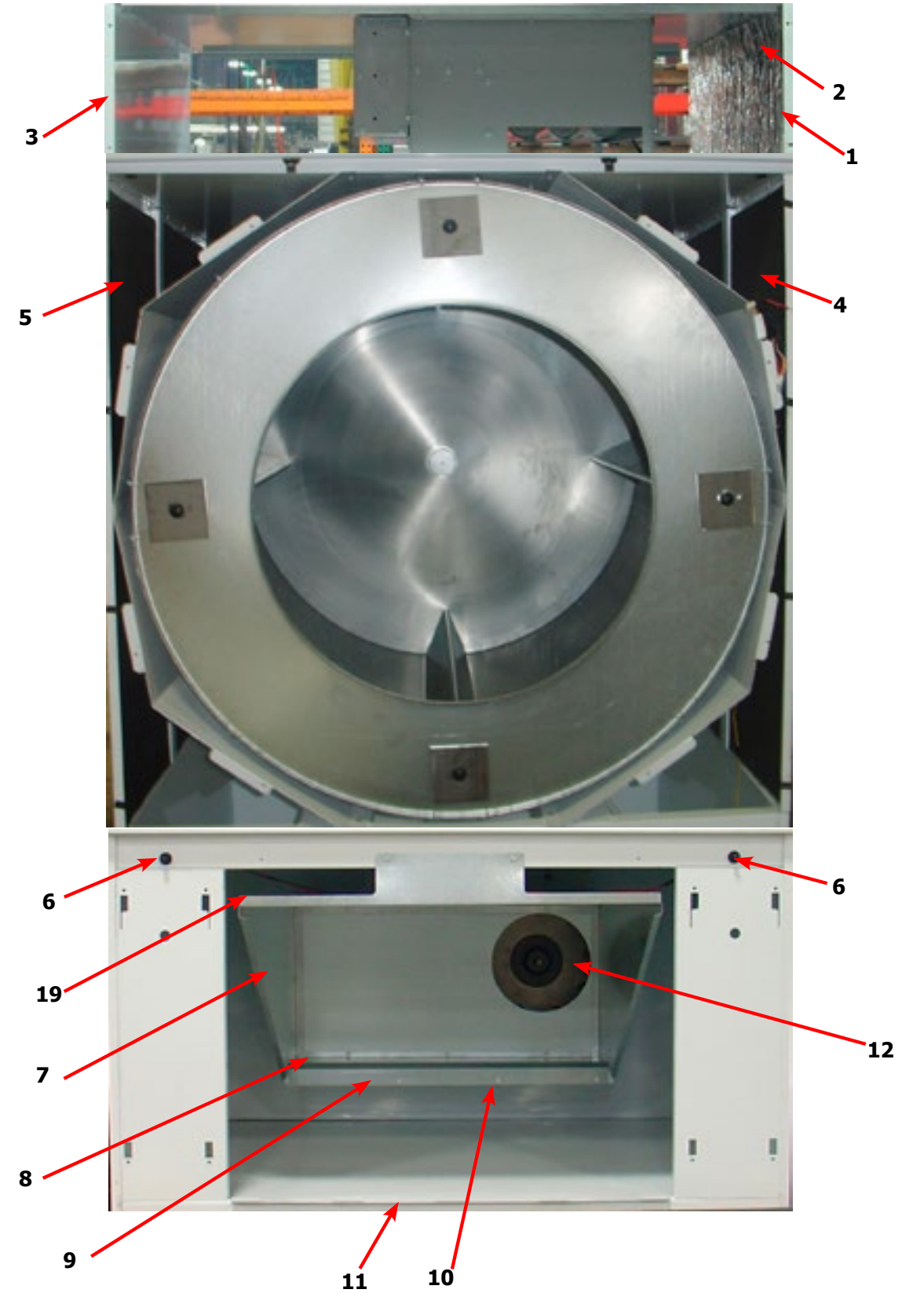
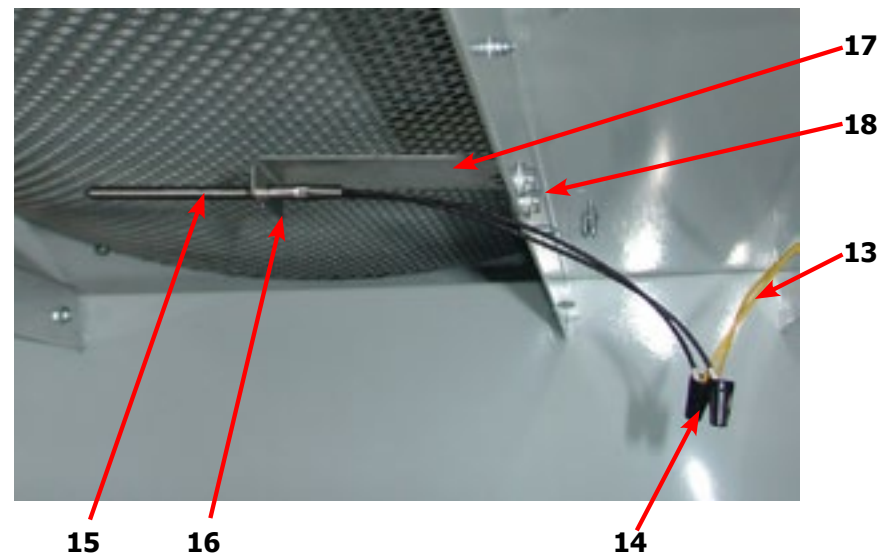

Dryer Modular Cabinet Group 120lb. (After Serial D1.23179.001)

Key	Description	T80	QTY
1	Cabinet Base Assembly	9945-172-001	1
*	Lower Back Panel Assembly	9989-754-002	1
2	Lower Cabinet RH Side Panel	9444-125-003	1
3	Lower Cabinet LH Side Panel	9444-125-004	1
4	Lower Cabinet Front Channel	9081-217-001	1
*	Upper Back Panel Assembly	9989-717-002	1
5	RH Middle Side Panel Assembly	9989-543-003	1
6	LH Middle Side Panel Assembly	9989-543-004	1
7	Cabinet Top Cover	9074-356-001	1
8	Baffle	9049-135-001	4
*	Baffle Stiffener Angle	9003-388-001	2
9	RH Upper Side Panel Assembly	9989-549-002	1
10	LH Upper Side Panel Assembly	9989-550-002	1
*	10abx3/8 Screw	9545-008-024	92
*	3/16 Blind Rivet	9491-009-001	131
*	Wht 3/16 Blind Rivet	9491-009-005	58
*	Hex kep Nut 1/4-20unc, 2b	8640-414-006	10

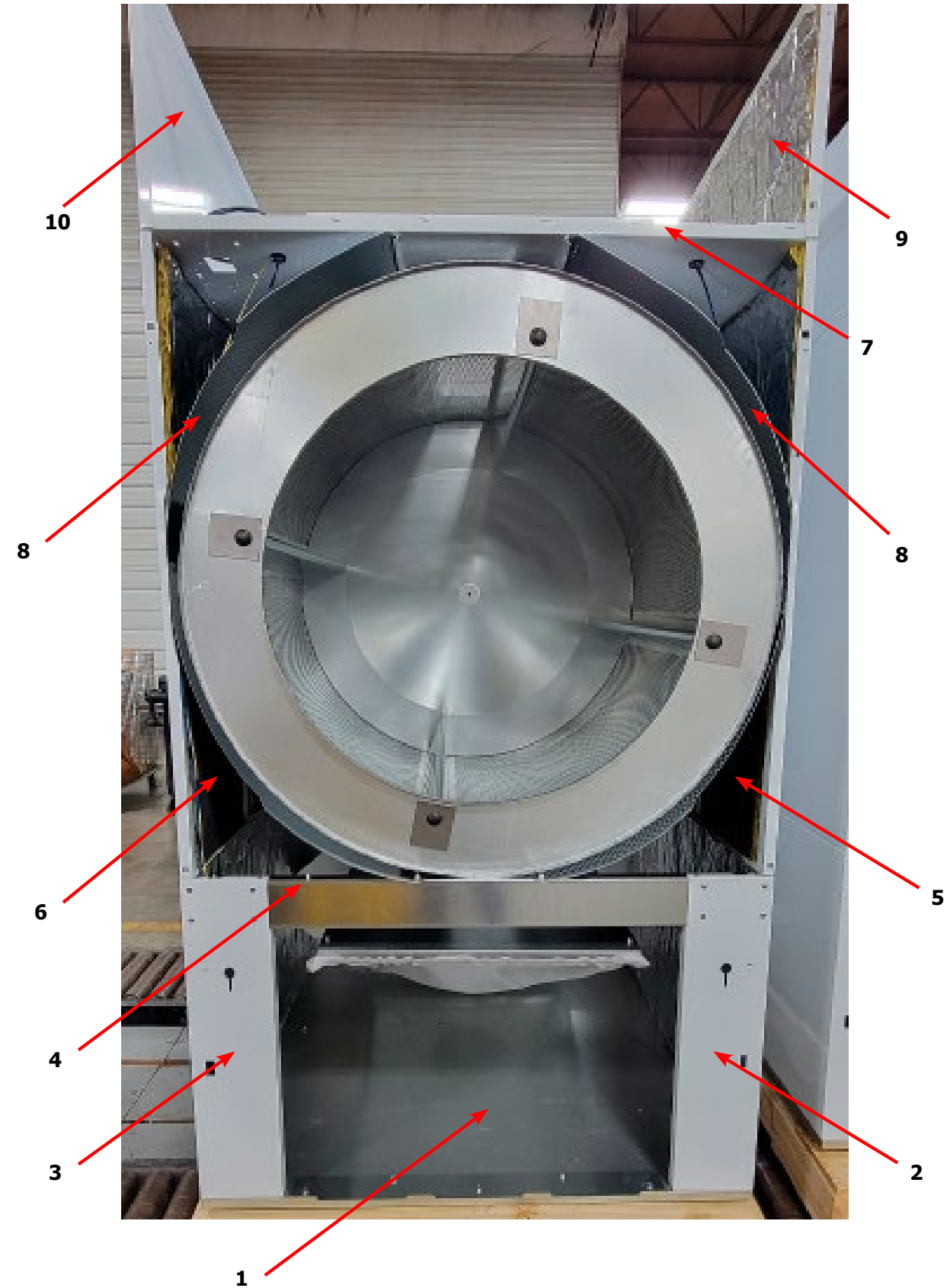

Dryer Rear View 120Lb Reversing

Key	Description	T-120	QTY
1	Pulley, Driven	9453-168-003	1
2	Tolerance Ring	9487-234-006	1
3	Washer -Flat	8641-581-032	1
4	LockWasher - IntTooth, 1"	8641-582-018	1
5	Screw, 5/8-11 x 1 1/2	9545-060-001	1
6	Belt-Driven	9040-076-005	2
*	Impeller, 5" x 16"	9278-041-001	1
7	Plate Assembly-Impeller	9982-375-002	1
8	Nut-Wiz Lock, 5/16-18	8640-400-003	6
*	Gasket-Impeller Housing	9206-428-002	1
9	Motor-Blower, -10 ,Before Serial #D1.19254.036	9376-317-005	1
9	Motor-Blower, -11 ,Before Serial #D1.19254.036	9376-334-001	1
9	Motor-Blower, After Serial #D1.19254.036	9376-334-001	1
10	Screw, 5/16-18 x 5/8	9545-014-004	4
11	Nut-Wiz Lock, 5/16-18	8640-400-003	4
12	Thermostat-Overtemp	9576-207-006	1
13	Screw-10AB x 3/8	9545-008-006	2
14	Pulley, Intermediate, w/Bearings	9908-051-001	1
*	Bearings-Ball	9036-159-011	2
*	Spacer-Bearings	9538-186-001	1
*	Ring-Retaining, Internal	9487-238-006	1
15	Washer-Flat	8641-581-039	1
16	Nut, 5/8-11	8640-425-002	1
17	Belt, Motor	9040-076-008	1
18	Motor, Drive	9376-307-003	1
19	Pulley-Motor	9453-169-012	1
20	Bushing, Motor -Support	9053-074-002	2
21	Rod-Motor Mounting, Black	9497-222-008	1
22	Collar-Shaft, w/Set Screws	9076-052-002	1
23	Chain-Belt tension	9099-012-004	1
*	Hook-S Type	9248-022-002	1

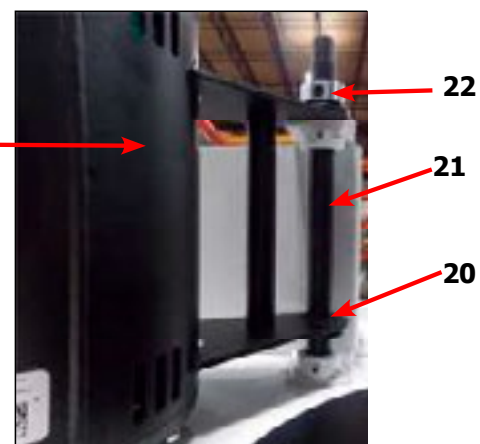
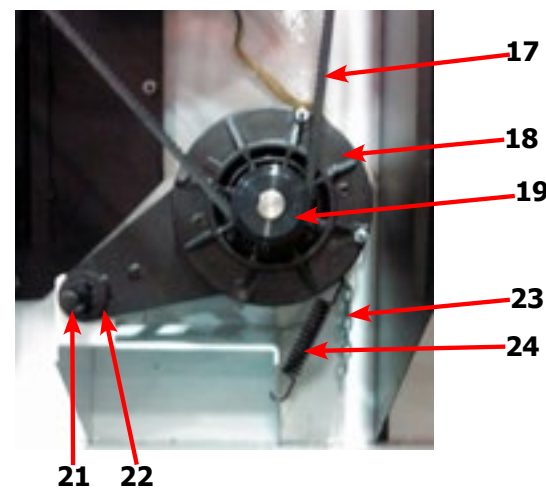

Dryer Rear View 120Lb Reversing

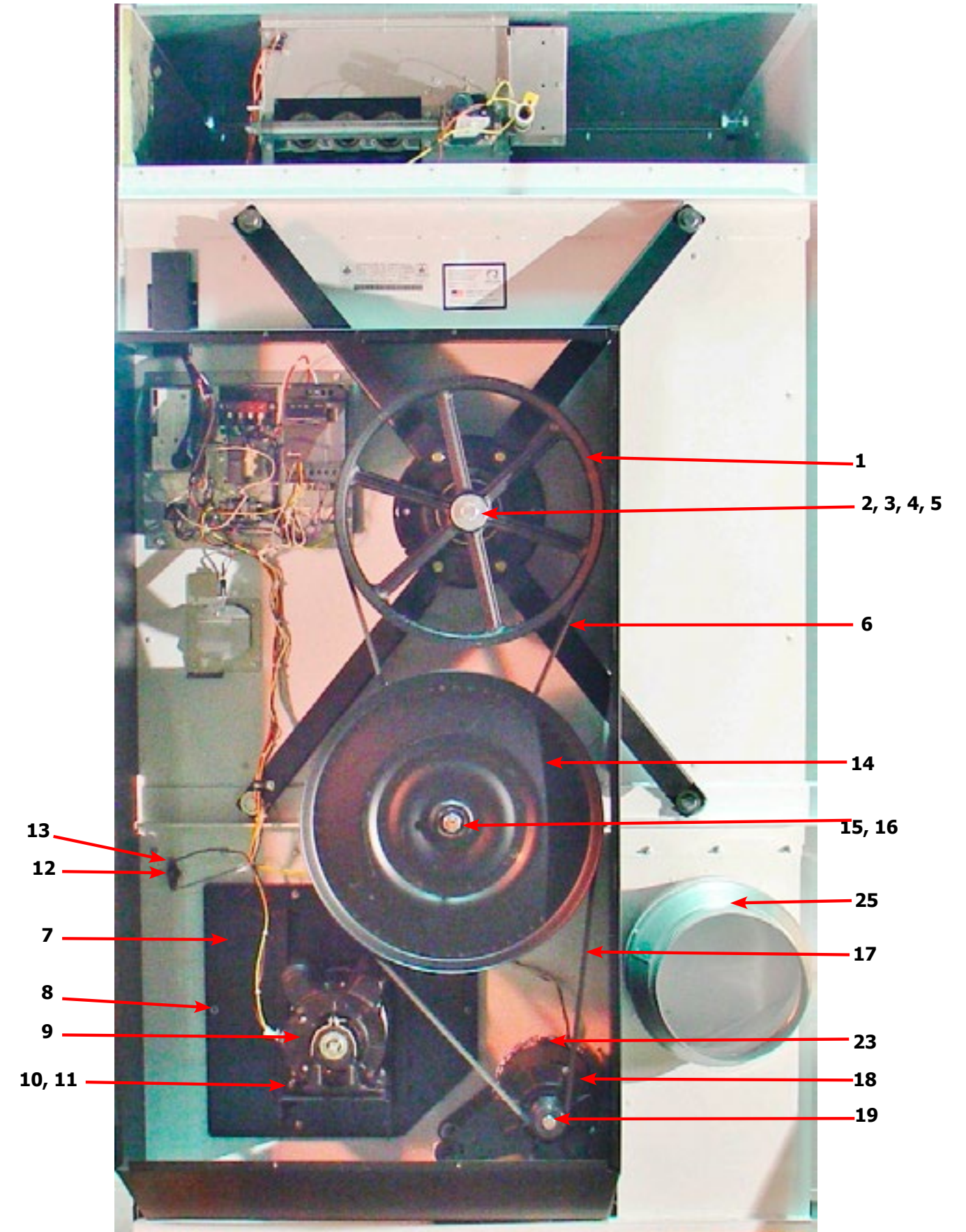

Dryer Rear View 120Lb Reversing Continued

Key	Description	T-120	QTY
1	Pulley, Driven	9453-168-003	1
2	Tolerance Ring	9487-234-006	1
3	Washer -Flat	8641-581-032	1
4	LockWasher - IntTooth, 1"	8641-582-018	1
5	Screw, 5/8-11 x 1 1/2	9545-060-001	1
6	Plate Assembly-Intermediate, Tension	9982-378-002	1
7	Rod-Intermediate, Pivot	9497-230-002	1
8	Collar, Locking	9076-060-001	1
9	Bolt, 1/2-13 x 1 1/2	9545-017-001	2
10	Thermostat-Overtemp	9576-207-006	1
11	Screw-10AB x 3/8	9545-008-006	2
*	Impeller, 5" x 16"	9278-041-001	1
12	Plate Assembly-Impeller	9982-375-002	1
13	Nut-Wiz Lock, 5/16-18	8640-400-003	6
*	Gasket-Impeller Housing	9206-428-002	1
14	Motor-Blower -10, Before Serial # D1.19254.036	9376-317-005	1
14	Motor-Blower -11, Before Serial # D1.19254.036	9376-344-001	1
14	Motor-Blower -10 & -11 After Serial # D1.19254.036	9376-344-001	1
15	Screw, 5/16-18 x 5/8	9545-014-004	4
16	Nut-Wiz Lock, 5/16-18	8640-400-003	4
17	Motor, Drive	9376-307-003	1
18	Pulley-Motor	9453-169-012	1
*	Bushing, Motor -Support	9053-074-002	2
19	Rod-Motor Mounting, Black	9497-222-008	1
20	Collar-Shaft, w/Set Screws	9076-052-002	1
21	Chain-Belt tension	9099-012-004	1
*	Hook-S Type	9248-022-002	1
*	Spring, Belt Tension	9534-151-000	1



7 8 6

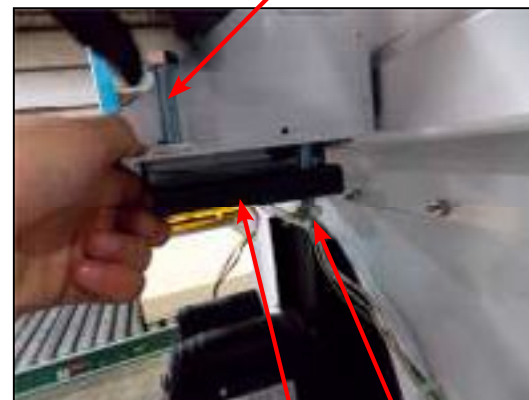

6 9

Dryer Rear View 120Lb Reversing Continued

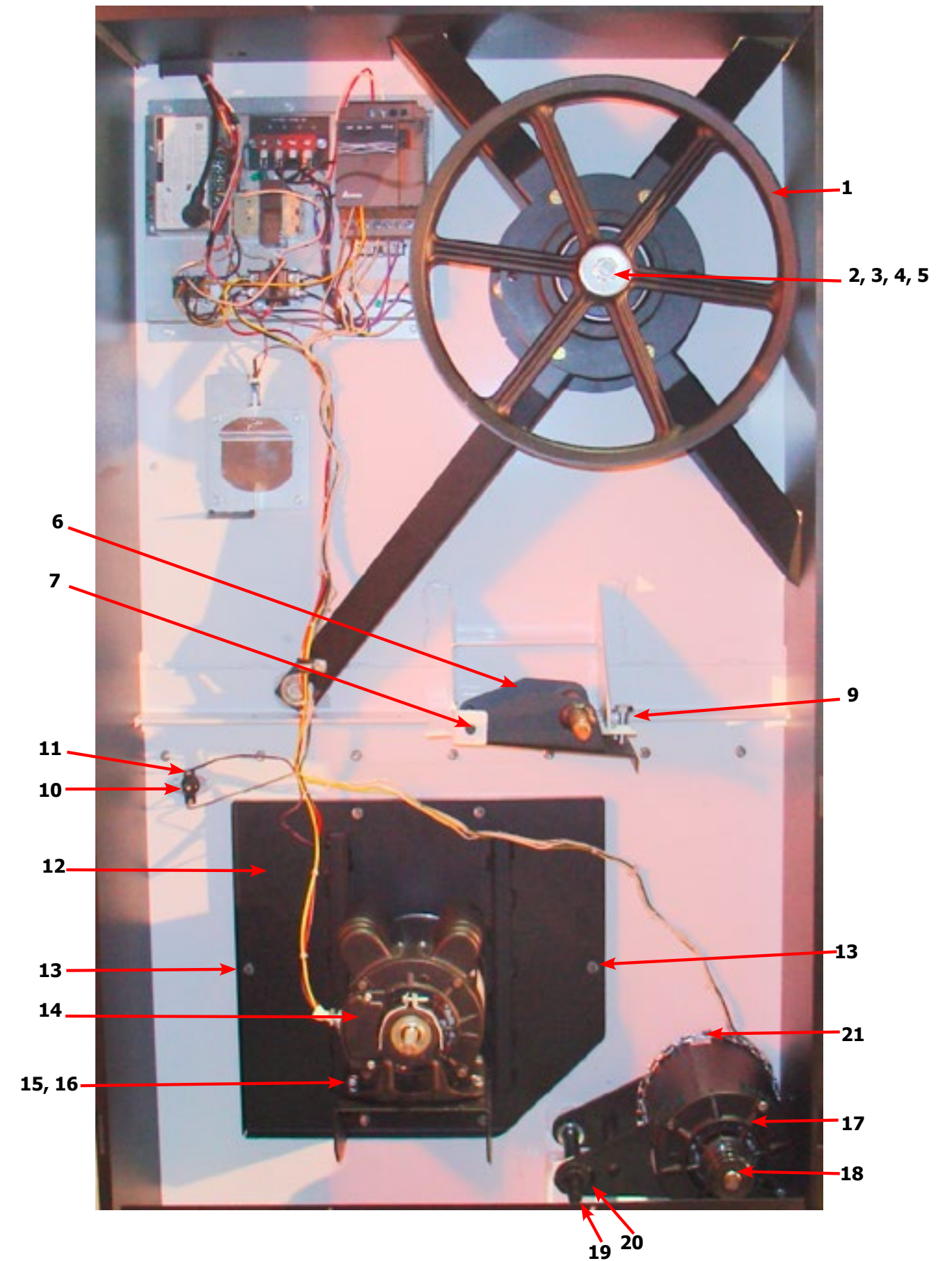

19 20

Dryer Rear View-Guard & Exhaust

Key	Description	T-120	QTY
1	Cover Cabinet	9074-356-001	1
*	Screw-5/16, 10ABx3/8	9545-008-024	16
2	Duct-Transition, 12" to 10"	9109-124-001	1
*	Screws-10-16 x 1/2	9545-008-003	3
*	Guard-Side, Right	9208-111-002	1
*	Screw-Torx T20, 10B x 3/8, BLK	9545-008-034	7
3	Guard-Side, Left	9208-110-002	1
*	Screw-Torx T20, 10B x 3/8, BLK	9545-008-034	8
4	Guard-Top	9208-112-002	1
*	Screw-Torx T20, 10B x 3/8, BLK	9545-008-034	11
5	Guard-Bottom	9208-113-002	1
*	Screw-Torx T20, 10B x 3/8, BLK	9545-008-034	6
6	Guard-Wires	9208-115-002	1
*	Screw-Torx T20, 10B x 3/8, BLK	9545-008-034	2
7	Guard-Door, Right	9208-114-004	1
*	Screw-Torx T20, 10B x 3/8, BLK	9545-008-034	6
8	Guard-Door, Left	9208-114-003	1
9	Screw-Torx T20, 10B x 3/8, BLK	9545-008-034	4
*	Nut-Spring, U-type	8640-399-001	4
*	Booklet-Owners	8514-215-001	1
10	Diagram & Schematics	9506-499-001	1
11	Label-Warning & Notice	8502-600-001	1
12	Label-Instructions	8502-645-001	1
13	Decal-Lighting & Clearance	8527-151-001	1
14	Label-High Voltage	8502-614-004	1

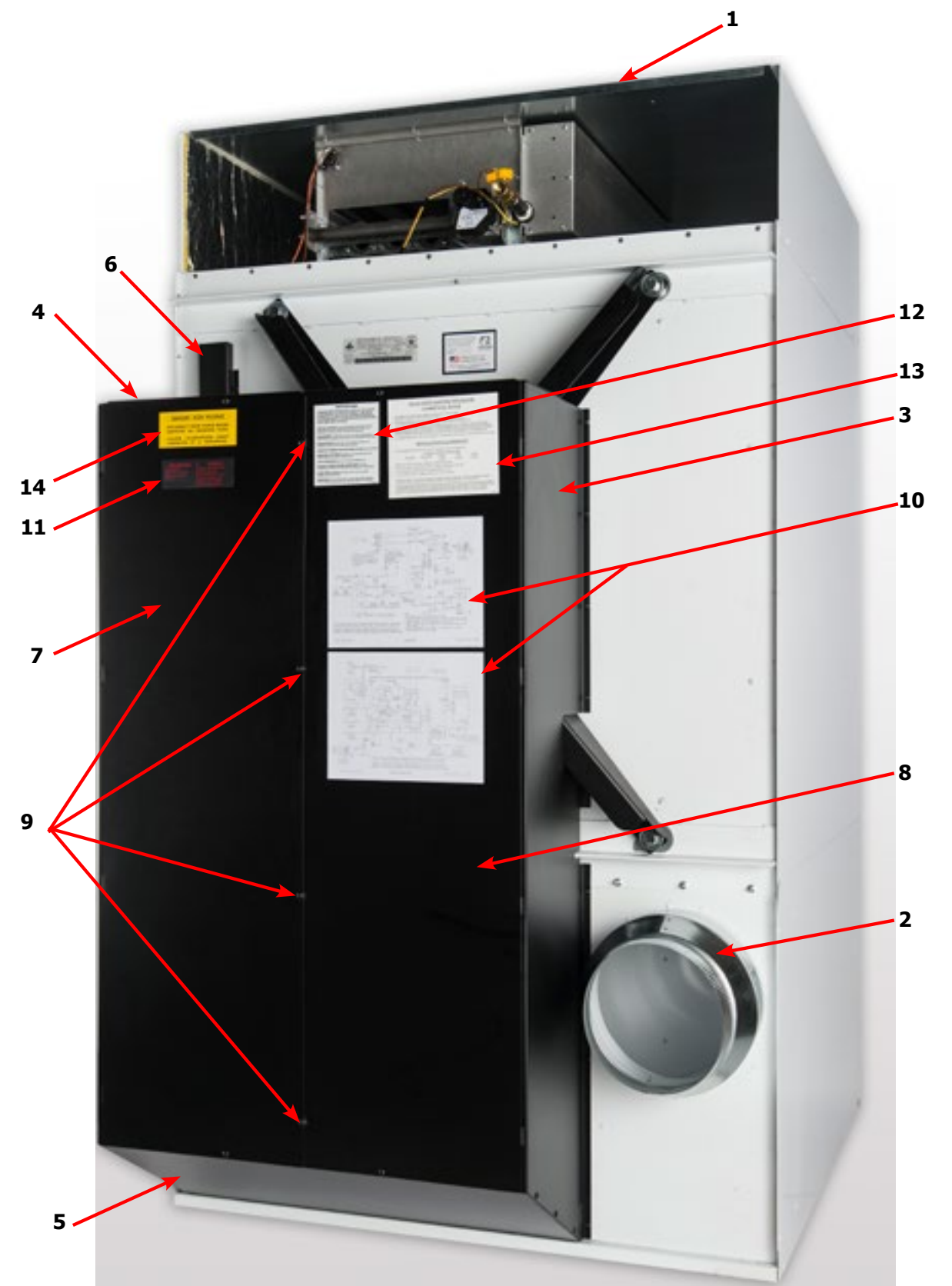

Dryer Rear View-Bearing Housing 120Lb

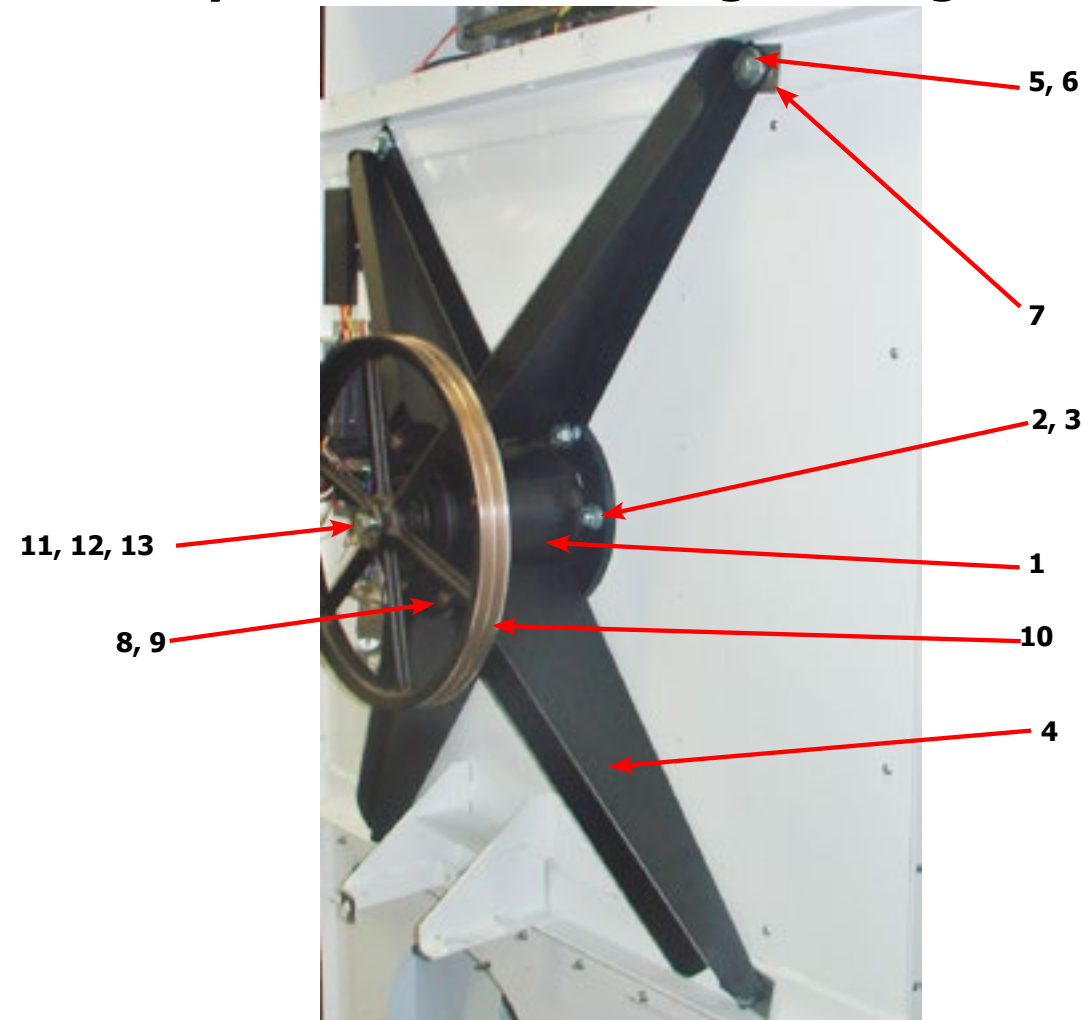

Key	Description	T-120	QTY
	Bearing Housing Complete Assy (Includes bearings & Spacer)	9803-186-001	1
1	Housing, Bearing	9241-180-002	1
*	Ring, Retaining-Internal	9487-238-003	1
*	Bearing, Ball, Front	9036-159-005	1
*	Spacer, Bearing	9538-167-001	1
*	Bearing, Ball, Rear	9036-159-004	1
*	Washer, Flat	8641-581-040	6
2	Screw-5/8"-11 x 1 1/2"	9545-060-001	6
3	Nut-Whizlock, 5/8" x 11	8640-425-001	6
4	Arm-Support Housing	9001-065-002	4
5	Screw-5/8-11 x 1 1/2	9545-060-001	4
6	Washer, Flat 5/8"	8641-581-038	4
7	Shim	9552-045-001	AR
8	Screw-7/16"-14 x 1 1/2"	9545-059-003	4
9	Nut-Whizlock, 7/16"	8640-416-005	4
*	Tolerance Ring	9487-234-006	1
10	Pulley Driven	9453-168-003	1
11	Washer, Flat 5/8" x 2 1/4"	8641-581-032	1
12	Lock Washer Spring, 1/2	8641-582-018	1
13	Screw, 5/8-11 x 1 1/2"	9545-060-001	1

Dryer Tumbler Group 80Lb

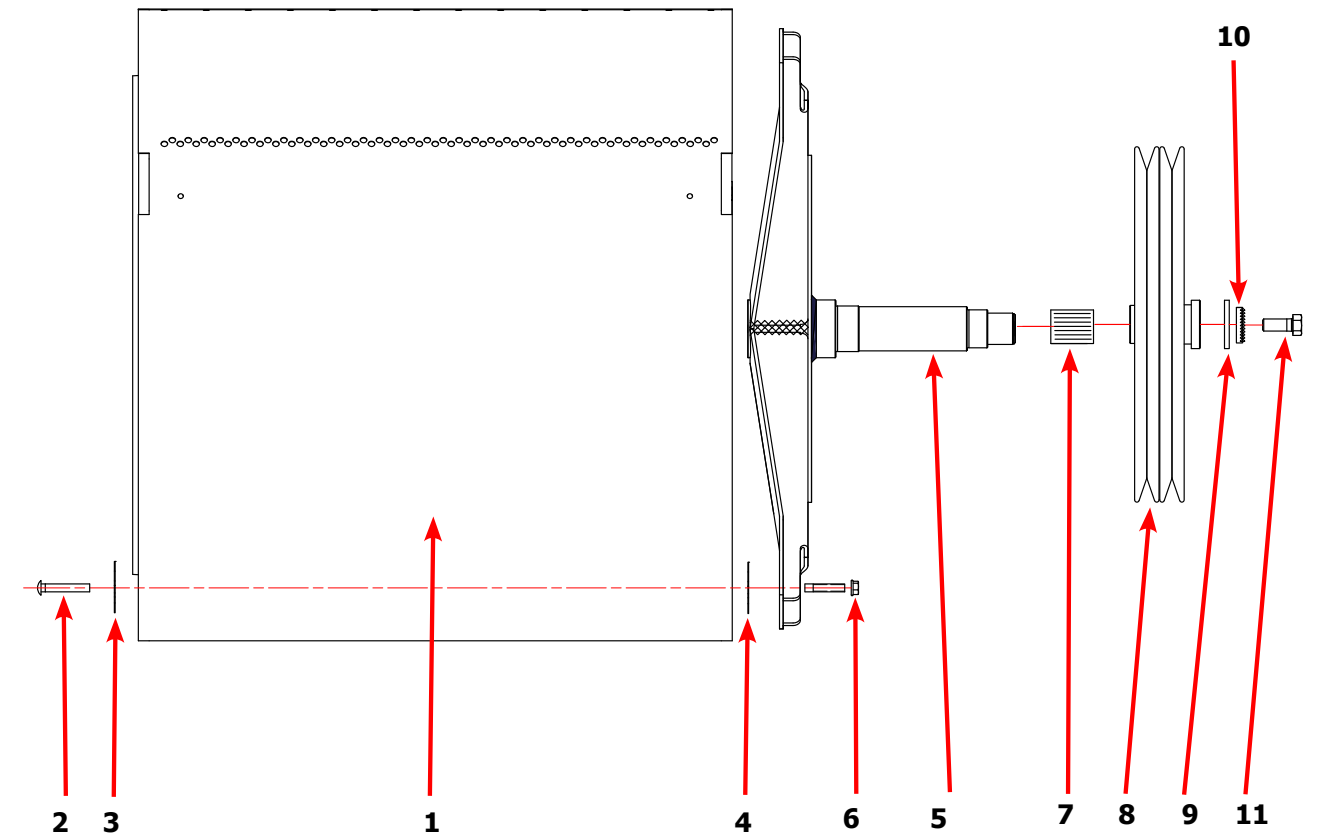

Key	Description	T-120	QTY
*	Tumbler Assy Complete W/Spider (GALV)	9848-152-001	1
1	Tumbler Assy (Galvanized)	9849-153-001	1
2	Rod, Tumbler	9497-266-003	4
3	Plate support, Tie Rod	9452-805-001	4
4	Shim	9552-013-003	AR
5	Spider Assy	9568-016-001	1
6	Nut, Wiz Lock	8640-417-005	4
7	Tolerance Ring	9487-234-006	1
8	Pulley, Driven	9453-168-003	1
9	Washer -Flat	8641-581-032	1
10	LockWasher - IntTooth, 1"	8641-582-018	1
11	Screw, 5/8-11 x 1 1/2"	9545-060-001	1

Dryer Burner Housing Group 120Lb

Key	Description	T-120	QTY
*	Housing Assembly, Burner	9803-213-001	1
1	Screw, 10ABx3/8	9545-008-024	55
2	Bracket-Support, Gas Valve	9029-240-001	1
3	Side-Extention Baffle, Burner Housing	9551-049-001	2
4	Burner, Main	9048-022-001	3
5	Baffle-Burner Housing, Extention	9049-105-001	1
6	Panel-Burner Housing, Front	9454-882-001	1
7	Panel-Burner Housing, Back	9454-883-001	1
8	Panel-Burner Housing, Side Left	9551-052-001	1
9	Baffle-Center, Burner	9049-106-001	1
10	Panel-Burner Housing, Side Right	9551-051-001	1
11	Channel-Burner Housing, Right	9081-164-001	1
12	Bracket-Manifold	9029-239-001	1
13	Bracket-Support, Burner, Front	9029-241-001	1
14	Bracket-Support, Burner, Rear	9029-242-001	1
15	Control Assy,Gas Valve, White Rodgers 36J	9857-193-001	1
16	Manifold Assy	9381-013-001	1
17	Top Assembly, Burner Housing	9961-161-001	1
18	Screw, 10Bx1/4	9545-008-001	18
*	Orifice-Natural, #10	9425-069-027	3
*	Orifice-LP, #32	9425-069-009	3
*	Kit, LP Conversion, White Rodgers	9732-102-025	1
19	Thermostat-HI-Limit	9576-203-002	1
20	Electrode-Ignition	9875-002-003	1
21	Bracket-Igniter	9029-243-001	1
22	Elbow-3/4 Street, Black	8615-104-042	1
23	Pipe-Nipple, 3/4 x 4", Black	8655-073-046	1
24	Valve-Gas Shutoff, (Optional)	9379-198-001	1

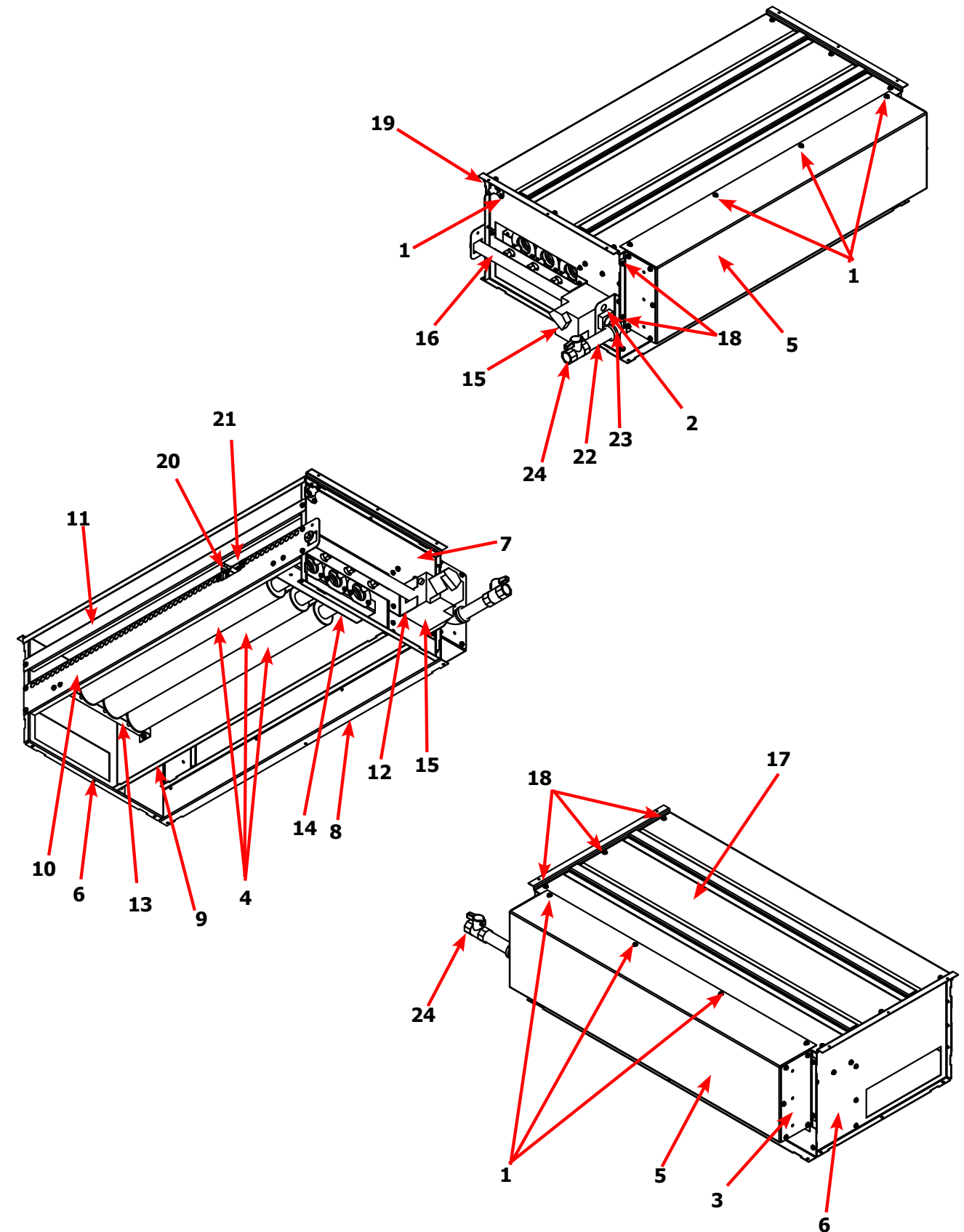

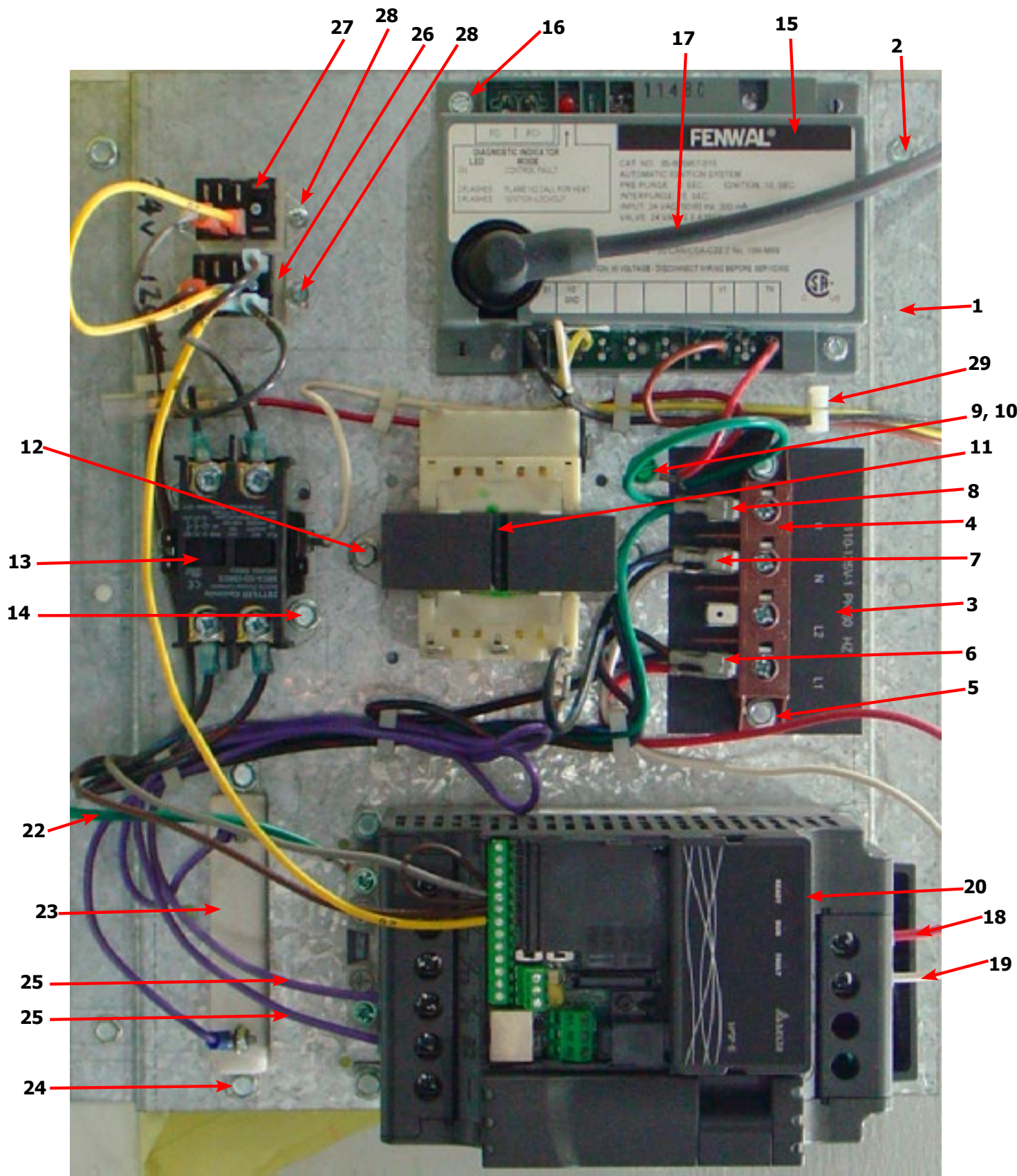

Dryer Rear View-Control Box

Key	Description	T-120	QTY
*	Control Assembly, (1 thru 28)	9857-195-001	
1	Channel-Controls	9081-163-001	1
2	Screw, 5/16-10AB-3/8	9545-008-026	6
3	Strip-Marker, Terminal	9558-029-005	1
4	Terminal Block Assy-Power, 4Pole	9897-035-001	1
5	Screw, 5/16-10AB-3/8	9545-008-024	2
6	Wire Assy-Blk/Red, 8 1/2"	8220-001-230	1
7	Wire Assy-Blk/Blu, 6 1/2"	8220-001-231	1
8	Wire Assy, GRN, 7"	8220-001-478	1
9	Screw- 10-32TTx1/2 GRN	9545-008-027	2
10	Lockwasher, External tooth	8641-582-006	2
11	Transformer, w/Circuit braker	8711-007-002	1
12	Screw, 5/16-10AB-3/8	9545-008-024	2
13	Relay-Motor, 30Amp, 24VAC	5192-299-002	1
14	Screw, 5/16-10AB-3/8	9545-008-024	2
*	Wire Assy-Blk/Red, 15"	8220-146-003	2
*	Wire Assy-Blk/Blu, 15"	8220-146-004	2
15	Control Assy, Ignition (Module)	9857-182-001	1
16	Screw-8Bx3/4"	9545-045-007	2
*	Harness, Ignition Module	9627-867-004	1
17	Wire Assy- High Voltage Lead	9631-403-005	1
18	Wire Assy-Red, 12"	8220-067-004	1
19	Wire Assy- White, 12"	8220-067-003	1
20	Drive-VFD Inverter, 1HP, 120VAC	9375-031-003	1
*	VFD Cooling Fan	9189-013-001	1
PS	Key Pad, Delta E-Drive	9150-044-001	1
21	Screw-#10B x 1/2	9545-008-026	4
22	Wire Assy-Green, 18"	8220-092-006	1
*	Wire Assy-BRN, 19"	8220-078-019	1
*	Wire Assy-Yellow, 20"	8220-082-002	1
*	Wire Assy-Gray, 18"	8220-078-018	1
*	Wire Assy, Brown 3"	8220-057-035	1
23	Resistor-Dynamic Breaking, 200OHM	9483-004-002	1
24	Screw-5/16, 10ABx3/8	9545-008-024	2
25	Wire Assy, Violet 24"	8220-118-001	2
26	Relay, 120VAC	5192-285-001	1
27	Relay, 24VAC	5192-285-004	1
28	Screw, 6B x 3/8	9545-031-005	4
*	Wire Assy-BLK/BLU, 15"	8220-150-002	1
*	Wire Assy-BLK/RED, 12"	8220-150-001	1
*	Harness, Control	9627-770-001	1
29	Stand off	9527-007-001	7

Wiring Schematic for 60hz Dryer -10BD

9506-499-001C

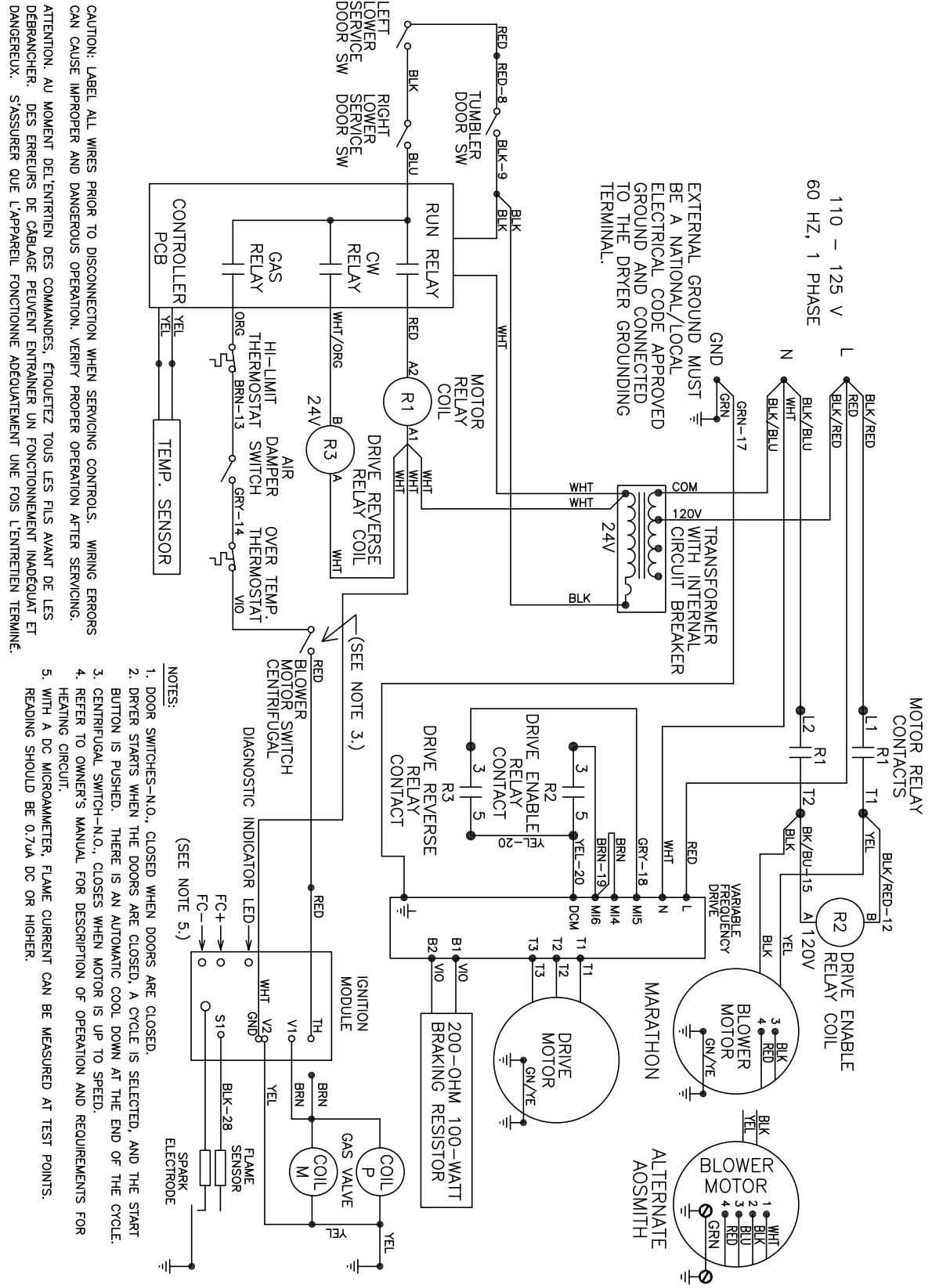

NOTES:

1. DOOR SWITCHES--N.O., CLOSED WHEN DOORS ARE CLOSED.
2. DRYER STARTS WHEN THE DOORS ARE CLOSED, A CYCLE IS SELECTED, AND THE START BUTTON IS PUSHED. THERE IS AN AUTOMATIC COOL DOWN AT THE END OF THE CYCLE.
3. CENTRIFUGAL SWITCH--N.O., CLOSES WHEN MOTOR IS UP TO SPEED.
4. REFER TO OWNER'S MANUAL FOR DESCRIPTION OF OPERATION AND REQUIREMENTS FOR HEATING CIRCUIT.
5. WITH A DC MICROMMETER, FLAME CURRENT CAN BE MEASURED AT TEST POINTS. READING SHOULD BE 0.7UA DC OR HIGHER.

SCHEMATIC

DCBD120HC--10BD

Wiring Diagram for 60hz Dryer -10BD

DCBD120HC--10BD

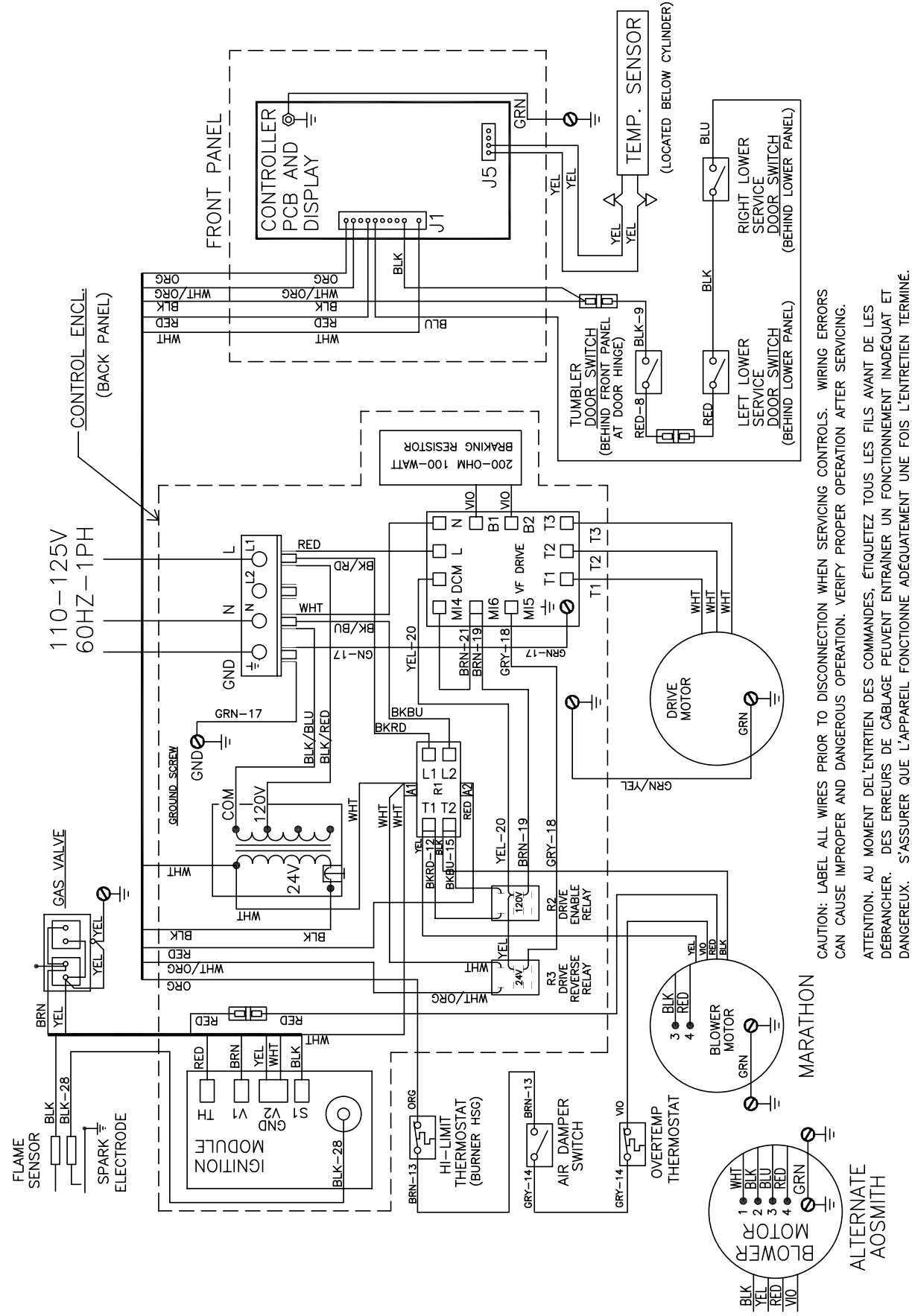

CAUTION: LABEL ALL WIRES PRIOR TO DISCONNECTION WHEN SERVICING CONTROLS. WIRING ERRORS CAN CAUSE IMPROPER AND DANGEROUS OPERATION. VERIFY PROPER OPERATION AFTER SERVICING.

ATTENTION: AU MOMENT DEL'ENTRIEN DES COMMANDES, ETIQUETEZ TOUS LES FILS AVANT DE LES DEBRANCHER. DES ERREURS DE CABLAGE PEUVENT ENTRAINER UN FONCTIONNEMENT INADEQUAT ET DANGEREUX. S'ASSURER QUE L'APPAREIL FONCTIONNE ADEQUATEMENT UNE FOIS L'ENTRIEN TERMINE.

WIRING DIAGRAM

9506-499-001C

**DCBD120HC_-39 230VAC 1 PH 50Hz
DN0120NC-39AB1R**

Key	Description	T-120	QTY
*	Motor-Drive	9376-307-003	1
*	Pulley	9453-169-009	1
*	Motor-Blower Before Serial # D1.19254.036	9376-317-006	1
*	Motor-Blower After Serial # D1.19254.036	9376-334-001	1
*	Capacitor, Run	5191-108-005	1
*	Capacitor, Start	5191-109-005	1
	Wiring Label-Schematic/Diagram	9506-500-001	1
	Orifice Main Burner, #30	9425-069-028	4
	Overlay-Trim Lower door	9435-016-007	1
	Label- Warning instructions	8502-698-001	1

Wiring Informative for 50hz Dryer -39BD

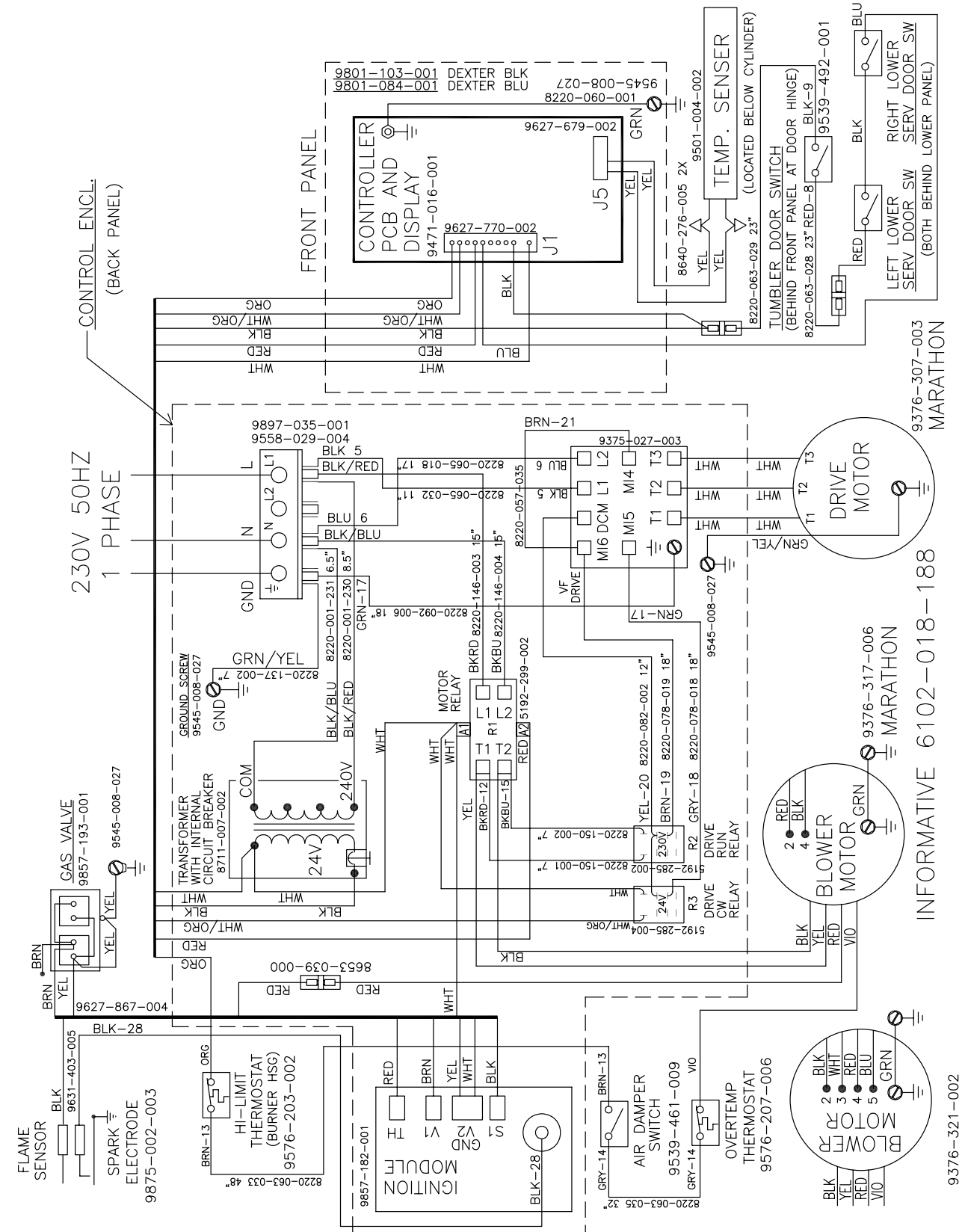

DCBD120HC_-39BD

INFORMATIVE 6102-018-188

9506-500-001A WIRING DIAGRAM

9376-321-002
AOSMITH

Key	Description	T-120	QTY
*	Control Assembly, (1 thru 28)	9857-195-002	
1	Channel-Controls	9081-163-001	1
2	Screw, 5/16-10AB-3/8	9545-008-001	6
3	Strip-Marker, Terminal	9558-029-004	1
4	Terminal Block Assy-Power, 4Pole	9897-035-001	1
5	Screw, 5/16-10AB-3/8	9545-008-024	2
6	Wire assy-Blk/Red, 6 1/2"	8220-001-230	1
7	Wire assy-Blk/Blu, 6 1/2"	8220-001-231	1
8	Wire Assy, GRN/YEL, 7"	8220-137-002	1
9	Screw- 10-32Tx1/2 GRN	9545-008-027	2
10	Lockwasher, External tooth	8641-582-006	2
11	Transformer, w/Circuit braker	8711-007-002	1
12	Screw, 5/16-10AB-3/8	9545-008-024	2
13	Relay-Motor, 30Amp, 24VAC	5192-299-002	1
14	Screw, 5/16-10AB-3/8	9545-008-024	2
*	Wire assy-Blk/Red, 9"	8220-146-003	2
*	Wire assy-Blk/Blu, 9"	8220-146-004	2
15	Control Assy, Ignition (Module)	9857-182-001	1
16	Screw-8Bx3/4"	9545-045-007	2
*	Harness, Ignition Module	9627-867-004	1
17	Wire Assy- High Voltage Lead	9631-403-005	1
18	Wire Assy-BLK, 11"	8220-065-032	1
19	Wire Assy- BLU, 11"	8220-065-018	1
20	Drive-VD Inverter, 1HP, 230VAC	9375-032-003	1
20	Key Pad, Delta E-Drive	9150-044-001	
21	Screw-#10B x 1/2	8640-413-002	4
22	Wire Assy-Green, 18"	8220-092-006	1
*	Wire Assy-BRN, 19"	8220-078-019	1
*	Wire Assy-Yellow, 20"	8220-082-002	1
*	Wire Assy-Gray, 18"	8220-078-018	1
*	Wire Assy, Brown 3"	8220-057-035	1
26	Relay, 230VAC	5192-285-002	1
27	Relay, 24VAC	5192-285-004	1
28	Screw, 6B x 3/8	9545-031-005	4
*	Wire Assy-BLK/BLU, 15"	8220-150-002	1
*	Wire Assy-BLK/RED, 12"	8220-150-001	1
*	Harness, Control	9627-770-002	1

Control Box Informatve for 50hz Dryer -39BD

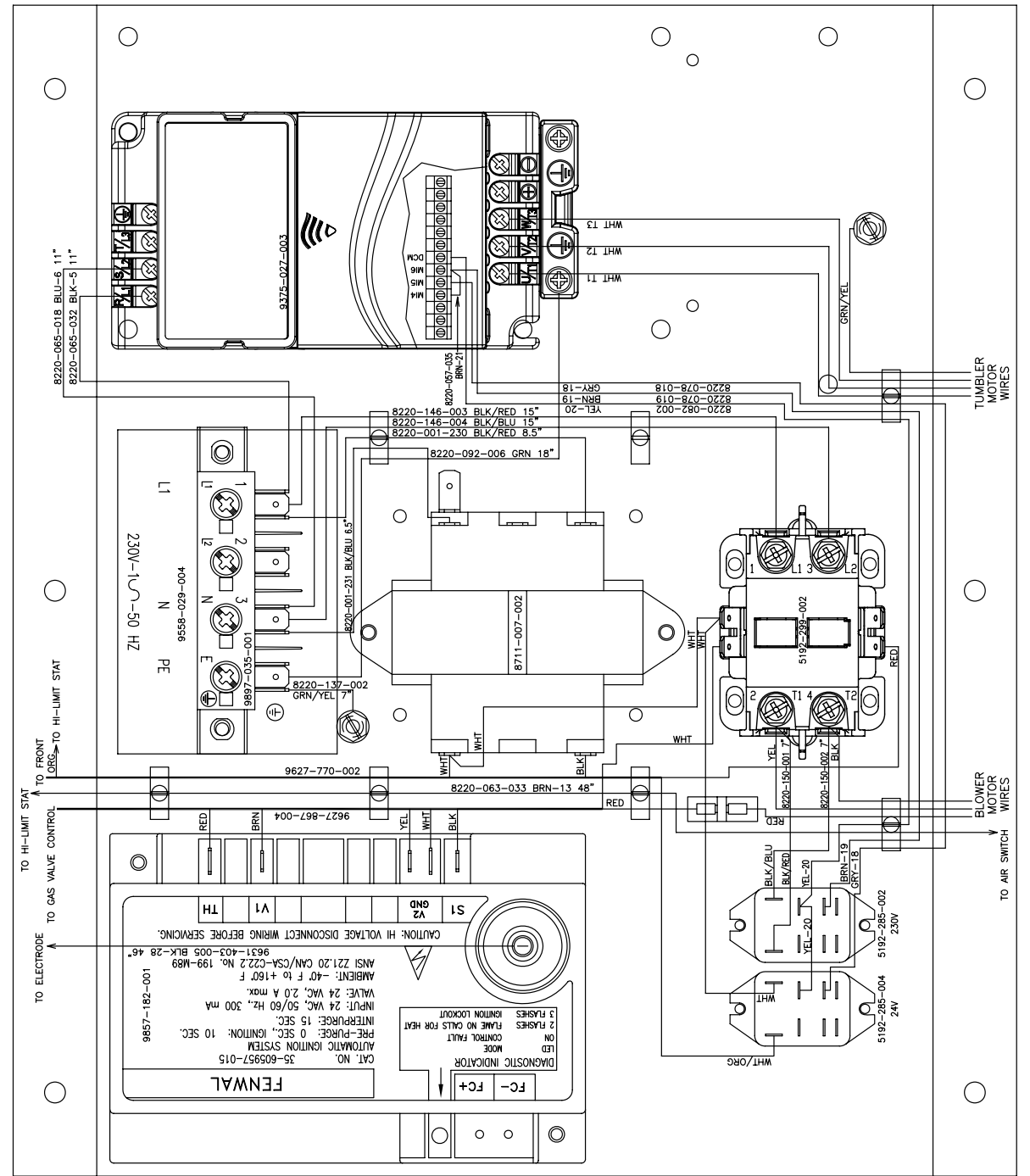

INFORMATIVE 6102-018-192

DCBD120HC_-39BD

SAMPLE BOX

9081-163-001B

