



DEXTER[®]
LAUNDRY

**USE THE BLUE TABS LOCATED ON THE
RIGHT AND LEFT SIDES OF THE FOLLOWING
DOCUMENT TO ADVANCE TO EACH SECTION.**

Kits, Assemblies, & Common Parts

Loading Door Components	Part Number
Door Handle	9244-082-001
Door Close Switch	9539-461-007
Electrical Components	Part Number
Transformer, Control	8711-007-001
Controls	9732-249-001
Heating Circuit Components	Part Number
Ignition Control Module	9857-116-003
Ignition Electrode Assembly	9875-002-003
Thermostat, Hi-Limit	9576-203-002
Thermostat, Overtemp	9576-207-006
Fuseholder	9200-001-002
Fuse 1.5 amp	8636-018-001
Airflow Switch	9539-461-009
Cabinet Components	Part Number
Cleanout Duct Assembly 8"	9973-034-001

Section 6: Parts Data

Cabinet Group

Key	Part Number	Description	Qty
*	9960-285-005	Door Assy., Loading Complete-Wht	1
*	9960-285-004	Door Assy., Loading Complete-SS	1
1	9960-284-002	Door Ring ONLY, Loading-SS	1
2	9982-360-003	Plate Assy., Hinge (Wht)	1
2	9982-360-001	Plate Assy., Hinge (SS)	1
*	9545-012-015	Screw, Hinge to Door 10-32 x 3/8"	4
*	8640-413-002	Nut, Hinge to Door #10-32 UNF	4
3	9212-002-004	Glass, Door	1
4	9206-164-010	Gasket, Glass	1
*	9548-117-000	Support, Door Glass (inside gasket)	1
5	9206-420-004	Gasket, Outer Rim	1
6	9244-082-001	Handle, Loading Door	1
*	9545-018-017	Screw, Handle 1/4"-20 x 3/8"	2
*	9531-033-001	Stud, Door Catch	1
*	8640-413-001	Nut, Hex	1
*	8640-413-003	Nut, Acorn # 10-32	1
*	9086-015-002	Catch, Loading Door	1
*	8638-190-009	Rivet, Door Latch	2
7	9454-809-007	Panel Assy., Front- White	1
7	9454-809-001	Panel Assy., Front- S. Steel	1
8	9108-102-001	Door, Upper Service-S.S	1
8	9108-102-004	Door, Upper Service-White	1
9	9578-091-003	Trim, Door-Upper Service	1
6292-006-006		Key (only) (FJWCC)	1
10	8650-006-003	Lock w/ nut, Upper Service Door	1
*	9491-009-001	Rivet, Drive, Upper Door Mounting	2
*	8641-581-005	Washer, Flat 3/16" Upper Door Mounting	2
*	9548-268-001	Support, Upper Door	1
11	9412-127-001	Nameplate, Commercial Dryer	1
12	9545-012-003	Screw, Chrome 10-32 x 1/2"	4
*	8641-436-004	Washer, Fiber	4
*	8641-582-019	Lockwasher # 10	10
*	8640-399-001	Nut, Spring U type 10Z	6
13	9544-069-002	Strap, Hinge (White)	1
13	9544-069-004	Strap, Hinge (Gray)	1
*	9545-008-032	Screw, Hinge to Panel 10T-32 x 3/4"	4
14	9545-052-001	Screw, Door to Hinge Strap (special)	1
*	8641-436-003	Washer, Fiber/ Plastic VSCO on Door Hinge (special)	1
15	9960-280-001	Door Ass'y, Lower Service-SS	1
15	9960-280-003	Door Ass'y, Lower Service-White	1
*	9277-050-001	Insulation Lower Door	1
16	9578-088-002	Trim, Door - Lower Service	1
23	9435-016-002	Overlay Trim	1
17	9545-008-021	Screw,Pn Hd Cr., #10Bx3/8	5
18	9578-084-003	Trim, Kick- Lower Service Door	1
19	9545-008-010	Screw, Tr Hd Cr-#10x1/2 Blk	3
20	9244-084-001	Latch, Lower Door (Handle)	1
*	8502-617-001	Label - Made in the USA	1
*	9277-051-002	Insulation Side Panel - Lower Service Area	3

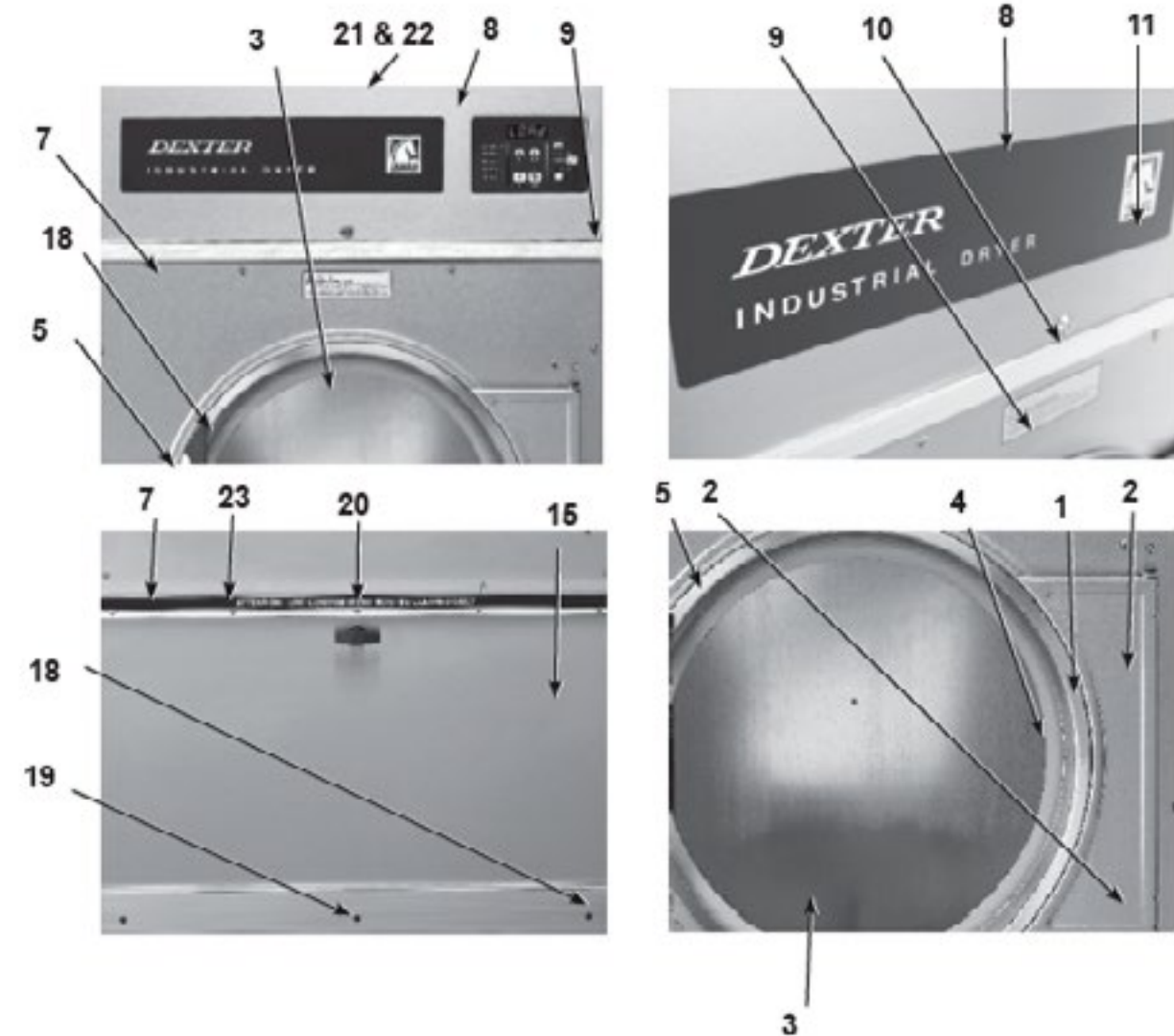

Key	Part Number	Description	Qty
*	9277-051-001	Insulation Side Panels - Around Basket	6
*	9277-055-002	Insulation Front Panel Bottom	1
*	9277-055-001	Insulation Front Panel Top	1
*	8544-006-001	Leg, Leveling	4
*	9812-012-001	Baffle, Cabinet- Left Inside Cabinet	1
*	9812-012-002	Baffle, Cabinet- Right Inside Cabinet	1
*	9545-008-003	Screw, #10x1/2 TEK	8
21	9074-276-001	Cover, Cabinet	1
22	9545-008-024	Screw 10AB x 3/8"	10
*	9277-041-003	Insulation	1
*	9277-047-002	Insulation 1/4" black	1

Front Control Housing Group

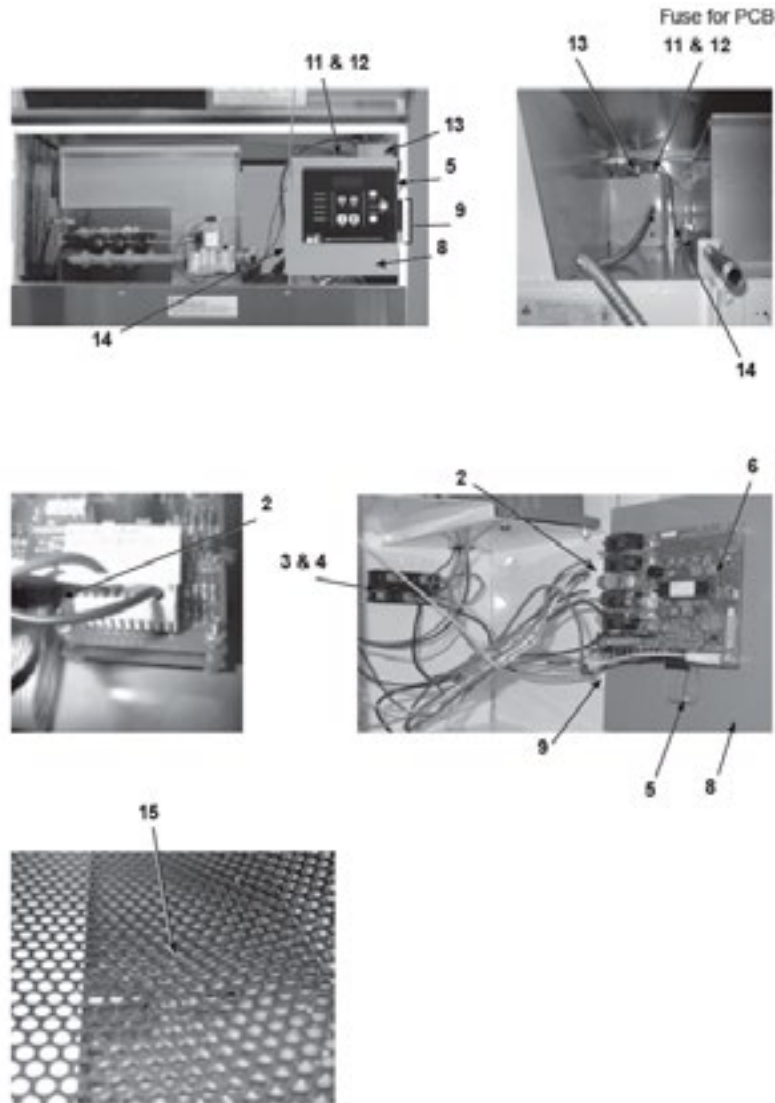

Key	Part Number	Description	Qty
2	9627-770-001	Wiring Harness Micro	1
3	9897-026-001	Terminal Block Assembly	1
4	9545-031-004	Screw 6AB x 3/8" (for terminal block)	2
5	9801-085-001	Membrane Switch Assembly	1
6	9732-249-001	PCB Board Controller	1
8	9982-326-002	Plate Assembly, Control Mounting	1
9	9451-146-005	Pin- Hinge meterplate	2
11	9054-045-001	Fuseholder	1
12	8636-018-001	Fuse 1.5 amp	1
13	9857-116-003	Control, Ignition	1
14	9631-403-003	Wire Ass'y High Voltage (from ignition control)	1
*	8636-024-001	Electronic Control PCB Fuse on PCB .600 MA/250V	1
15	9501-004-002	Temperature Sensor	1
*	9627-679-002	Sensor Wire Harness	1
*	9029-111-001	Bracket Sensor Mounting	1
*	9545-045-005	Screw Mounting Bracket 8B x 1/4"	1

Drive Group

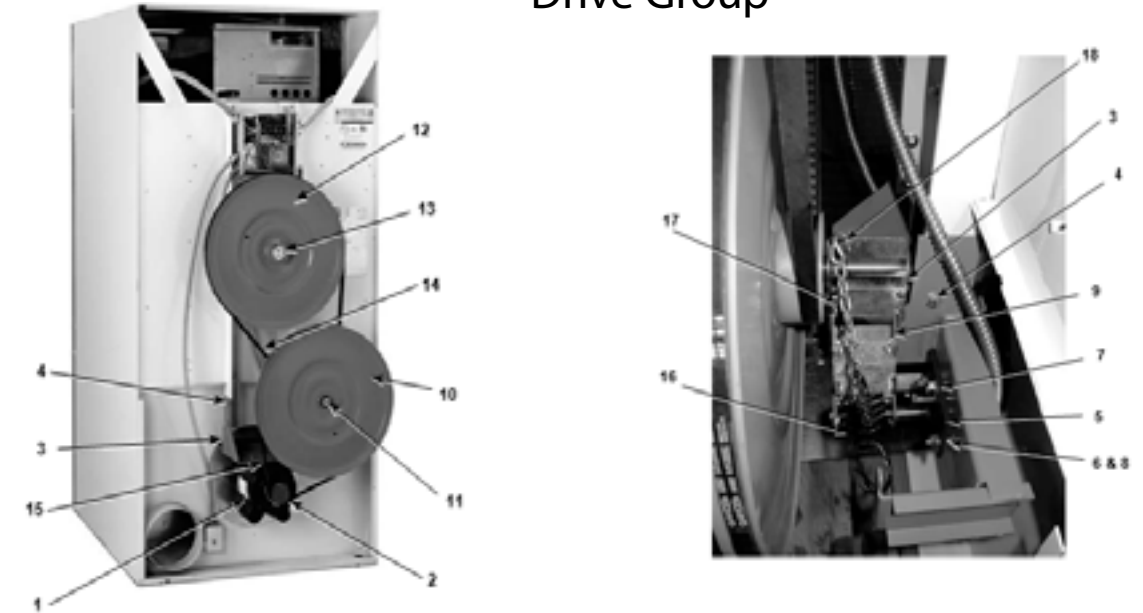

Key	Part Number	Description	Qty
1	9376-300-001	Motor, Drive	1
*	9732-205-007	Motor Replacement Kit	1
*	9545-014-004	Screw, Hx 5/16-18 x 5/8"	4
*	8640-400-003	Nut 5/16-18	4
2	9453-169-010	Pulley, Motor	1
*	9545-028-013	Screw, Set	2
3	9991-054-004	Support Assembly, Motor	1
4	9545-014-004	Screw	4
*	8640-400-003	Nut	4
5	9991-053-001	Support Assembly, Intermed. Pulley	1
6	9545-029-010	Bolt, Rd Hd, 3/8-16 x 1 1/4"	3
7	9545-029-003	Screw, 3/8-16 x 1 1/2"	1
8	8640-415-004	Nut 3/8-16	3
*	8641-581-035	Washer, Flat	4
9	9861-024-003	Arm Assembly-Tension	1
*	8641-581-035	Washer, Flat	1
*	9487-200-006	Ring-Retaining	1
10	9908-042-006	Pulley Assembly, Intermediate - w/bearings	1
11	9036-159-007	Bearing, Ball-Idler Pulley	2
*	9538-173-002	Spacer, Bearing	1
12	9908-043-002	Pulley Driven	1
*	9487-234-001	Ring, Tolerance	1
13	8641-581-026	Washer, Flat	1
13	8641-582-016	Lockwasher	1
13	9545-017-009	Screw, Hx Cap	1
14	9040-077-005	Belt, Final Drive	1
15	9040-077-003	Belt, Motor Drive	1
16	9534-151-000	Spring, Belt Tension	1
17	9099-012-002	Chain, Spring Tension	1
18	9248-022-002	Hook, Tension	1
*	9208-066-001	Guard, Drive	1
*	9454-692-001	Panel, Drive Guard, RH	1
*	9454-693-001	Panel, Drive Guard, LH	1
*	9550-175-001	Shield, Motor	1
*	9545-008-003	Screw	2

Rear Control Group

Key	Part Number	Description	Quantity
1	9041-081-001	Box , Control.....	1
*	9074-304-001	Cover, Control Box Upper.....	1
*	9545-008-024	Screw 10AB x 3/8".....	4
2	5192-295-011	Relay (Large).....	1
*	9545-044-002	Screw, #8ABx 3/8.....	2
3	9897-035-001	Terminal Block Assembly, Power.....	1
4	9558-029-005	Strip , Terminal Marker.....	1
*	9545-045-002	Screw, #8ABx 3/8.....	2
*	9074-305-001	Cover control box lower.....	1
10	8639-621-007	Screw #10-32 x 1/2 GRN.....	1
*	8640-411-003	Nut Hexkeys #6-32.....	2
9	5192-285-001	Relay (Clear).....	1
11	8711-007-001	Transformer.....	1
*	9545-012-009	Screw--#10-32 x 1/2" Mtg Transformer.....	2
*	8640-413-002	Nut Hex #10-21 UNF Mtg Transformer.....	2
*	9545-031-003	Screw #6Bx 3/8 Mount Small Relay.....	2
*	8220-063-018	Wire Assembly White 8".....	1
*	8220-001-230	Wire Assembly Black/Red 8 1/2".....	1
*	8220-001-231	Wire Assembly Black/Blue.....	1
*	8220-001-452	Wire Assembly White 12 1/4".....	1
*	8220-001-478	Wire Assembly Green 7".....	1
*	8220-067-001	Wire Assembly Black/Red 7 3/4".....	1
*	8220-067-002	Wire Assembly Black/Blue 7 3/4".....	1
12	9376-300-001	Motor.....	1

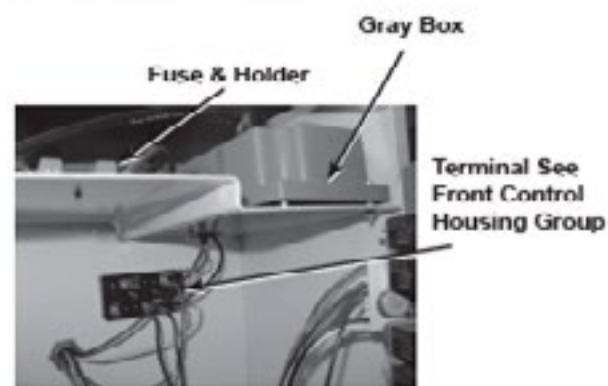

Rear Guard Group

Key	Part Number	Description	Quantity
1	9208-066-001	Drive Guard.....	1
2	9454-692-001	Right Side Panel Drive Guard.....	1
3	9454-693-001	Left Side Panel Drive Guard.....	1
4	9550-175-001	Motor Shield.....	1
*	9545-008-003	Screw 10-16 x 1/2 TEK.....	2
*	9545-008-001	Screw 10 B x 1/4.....	11

* Not Illustrated

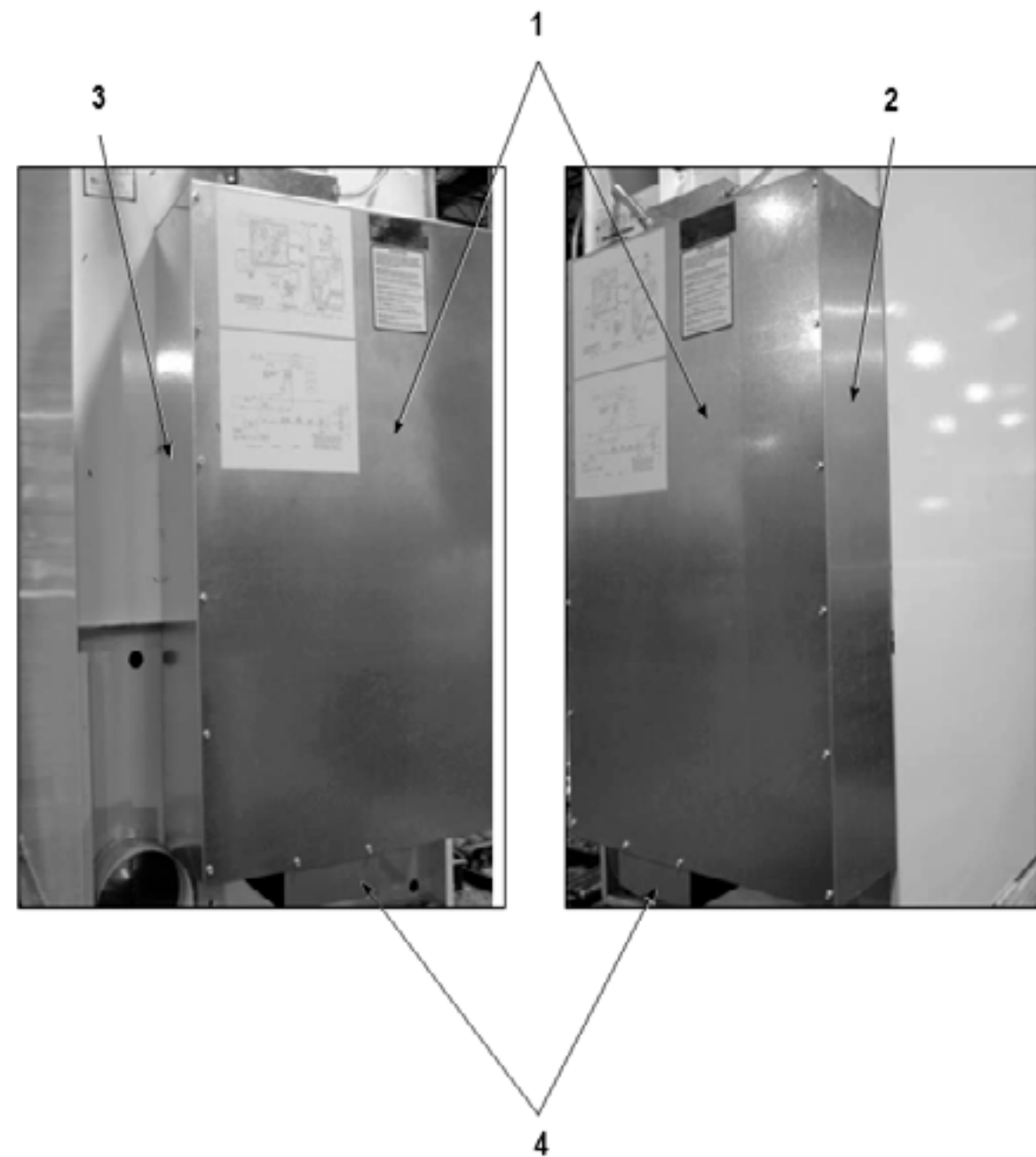

Burner Housing Group

Key	Part Number	Description	Quantity
1	9803-196-001	Housing Assembly, Burner	1
*	9545-008-024	Screw	2
2	9048-018-001	Burner, Main	3
*	9545-008-008	Screw 8B x 1/14"	3
3	9875-002-002	Electrode, Ignition	1
4	9452-645-001	Plate, Electrode Mtg	1
*	9545-008-024	Screw, Electrode Mtg 8B x 10x 3/8"	2
6	9857-134-001	Control Assy, Gas	1
7	9381-010-001	Manifold, Assy 3 port	1
*	9425-069-021	Orifice, Burner-Natural	3
*	9425-069-022	Orifice, Burner-LP	3
8	9576-203-002	Thermostat, Hi-Limit	1
*	9538-142-001	Spacer, Hi-Limit	2
*	9545-045-007	Screw 8B x 3/4"	2
19	9074-234-001	Cover, Hi-Limit Stat	1
*	9545-008-024	Screw 10 B x 3/8"	1
*	9857-116-003	Control, Ignition (Gray Box)	1
*	9545-044-002	Screw 6-32 x 1"	2
*	8640-411-003	Nut, Hex Keps #6-32	2
*	9897-026-001	Terminal Block Power (Inside Control Panel)	1
*	9545-031-004	Screw 6 AB x 5/8"	2
*	9039-915-001	BRACKET, Pipe gas line	1
*	9545-008-003	Screw 6AB x 5/8"	2
21	9631-403-003	Wire Ass'y, High Voltage	1
20	9627-711-001	Harness, Low Voltage Ignition	1
*	9054-045-001	Fuseholder	1
*	8636-018-001	Fuse 1.5 amps	1
*	8711-007-001	Transformer, Control (In rear control box)	1
*	9545-012-009	Screw, #10x1/2"	2
*	9732-102-010	Kit, LP Conversion	1
13	9548-280-001	Support, Front Burner	1
14	9545-008-008	Screw 10T-32 x 1/2"	3
*	9454-738-001	Left side burner housing	1
*	9454-572-001	Right side burner housing	1
9	9379-164-001	Valve, Gas Shut-Off w/ brass union	1
10	9458-020-003	Pipe, Gas Line	1
*	9454-737-001	Front Side Burner Housing	1

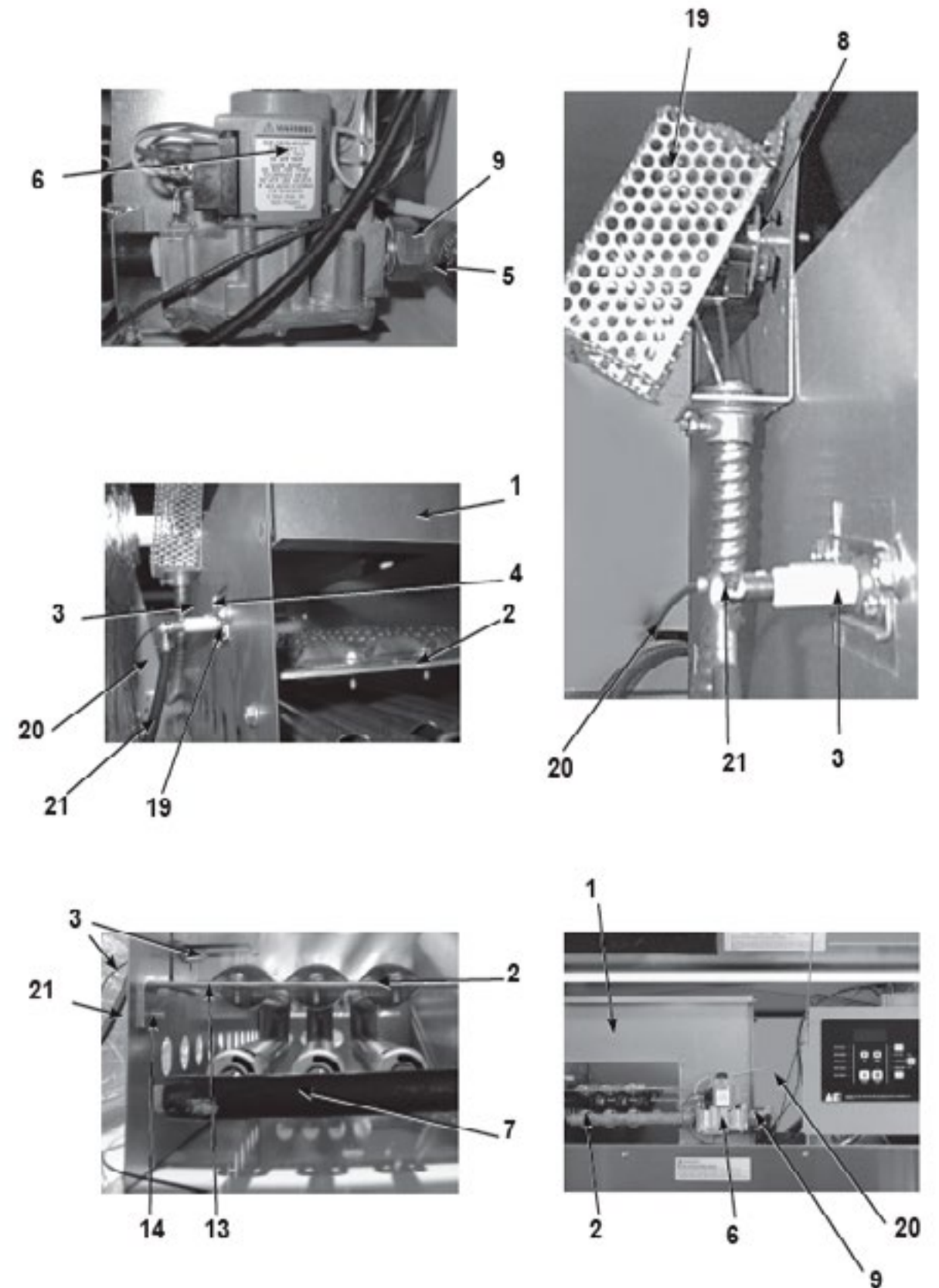

Bearing Housing Group

Key	Part Number	Description	Qty
*	9803-189-001	Housing, Bearing Ass'y w one(rear) bearing	1
1	9241-183-003	Housing, Bearing	1
2	9036-159-001	Bearing, Ball-Rear	1
*	9036-159-002	Bearing, Ball-Front	1
3	8641-581-026	Washer, Flat 1/2"	4
4	8641-582-004	Lockwasher spring 1/2"	4
5	9545-017-004	Bolt, 1/2-13x1	4
6	9545-059-003	Screw, 7/16-14x1 1/2	2
*	8641-582-013	Lockwasher, 7/16	2
7	8640-416-001	Nut, 7/16-14.	4

* Not Illustrated

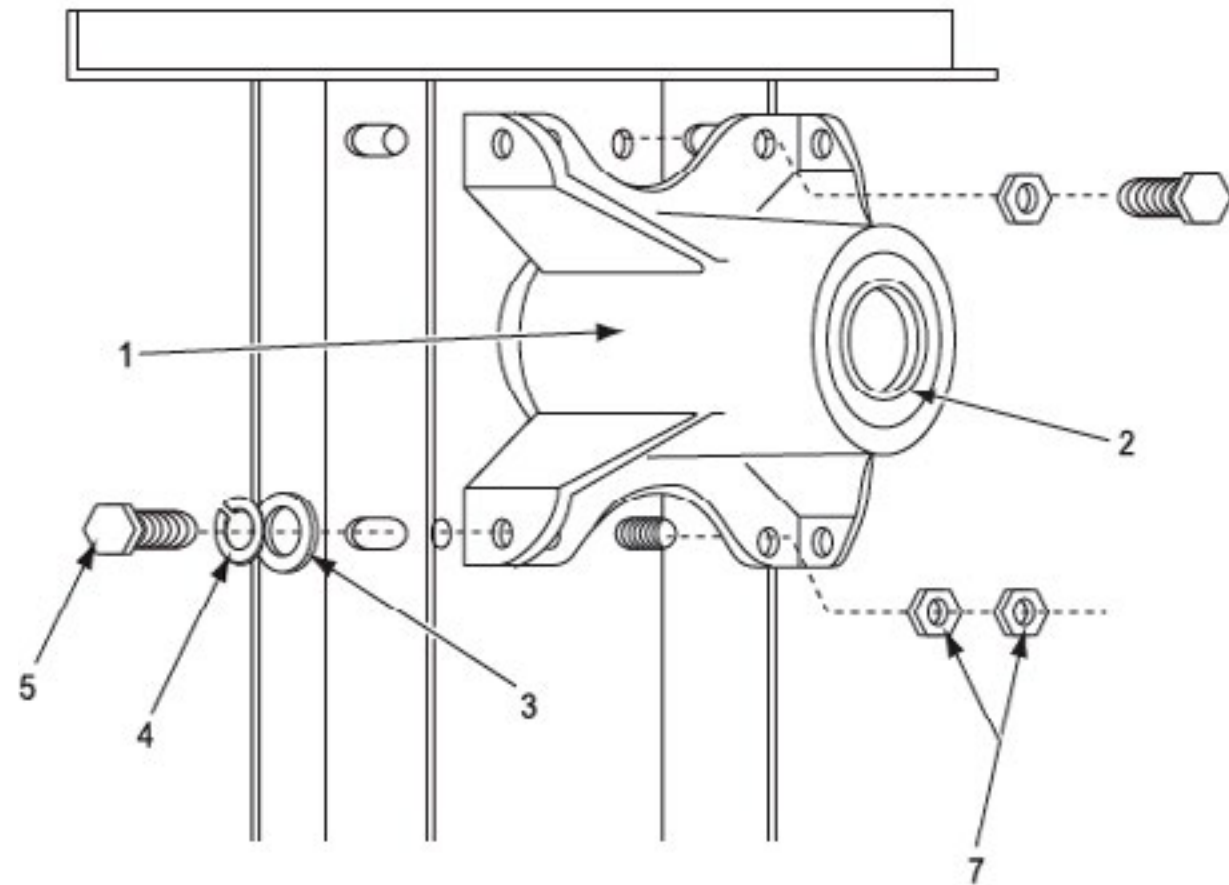

Tumbler Basket Group

Key	Part Number	Description
1	9848-132-001	Tumbler Ass'y
*	9848-132-002	Tumbler Ass'y, SS.....
2	9873-005-001	Spider Ass'y with bearing on.....
3	9497-226-001	Rod, Tumbler
4	8640-417-005	Nut
5	9552-013-000	Shim.....
7	8641-590-002	Washer, Tumbler Rod Special
*	9487-234-001	Ring, Tolerance.....
8	8641-582-016	Lock Washer ext tooth 1/2", Tumbler Shaft
9	8641-581-026	Flat Washer 1/2",Tumbler Shaft.....
10	9545-017-009	Screw, Tumbler Shaft 1/2-13 x 11/4"

* Not Illustrated

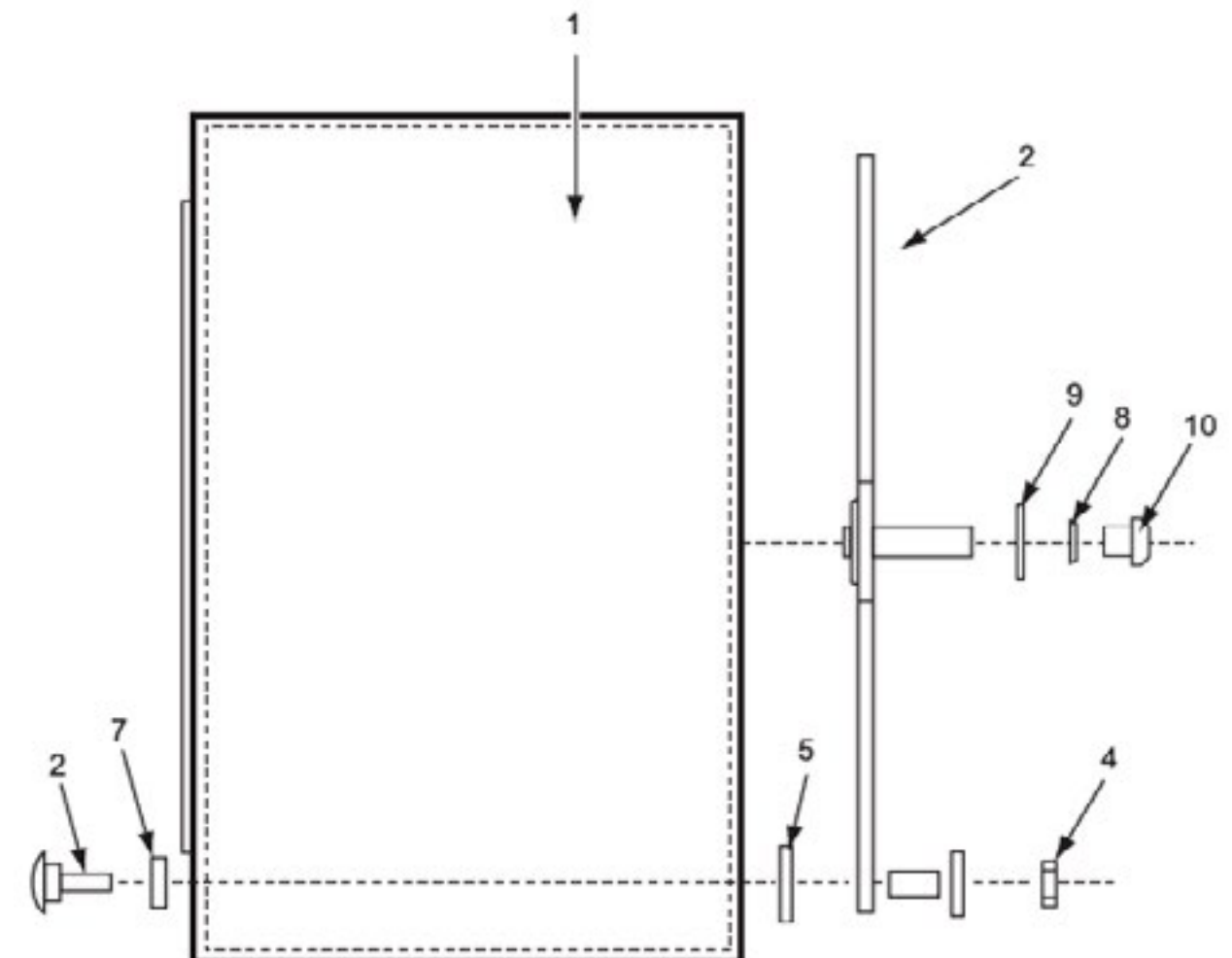

Blower Impeller and Air Flow Switch Group Over Temperature Switch

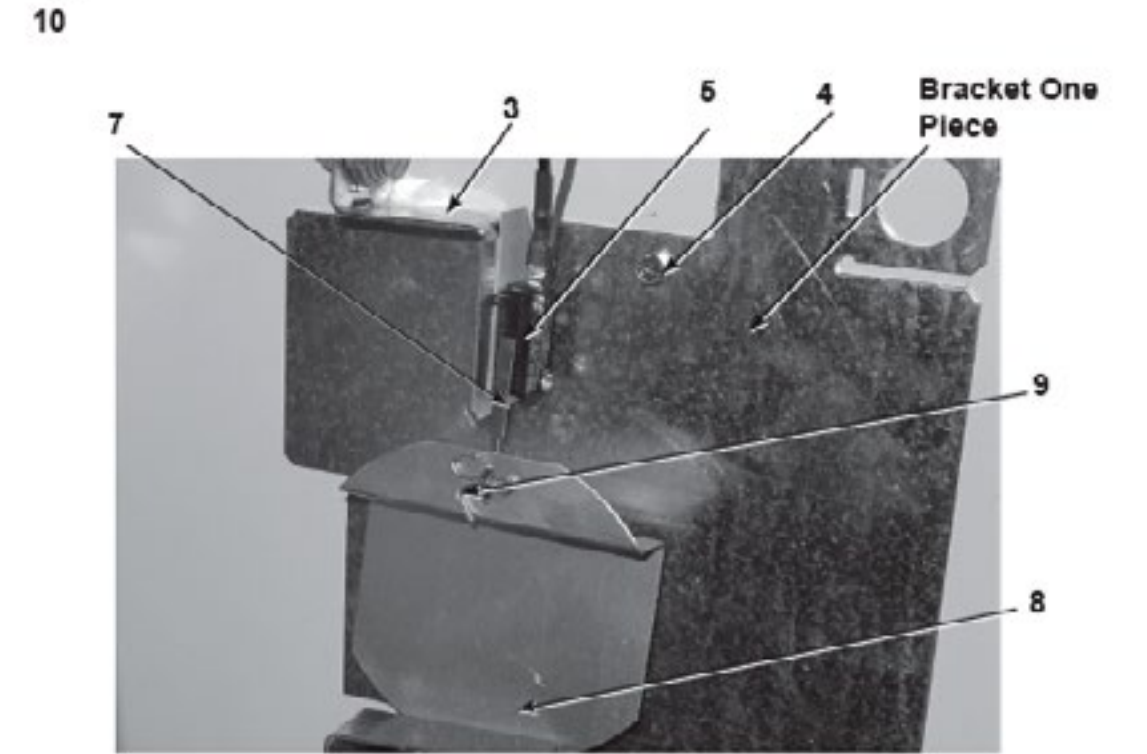
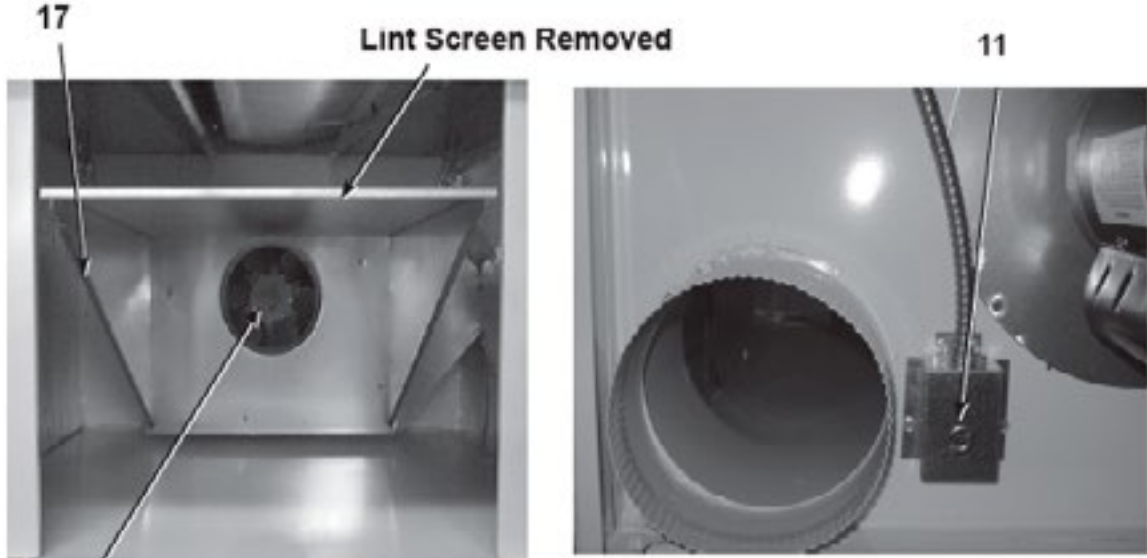

Key	Part Number	Description	Quantity
3	9029-135-002	Bracket -Switch One Piece.....	1
4	9545-008-024	Screw-10B x 1/4.....	2
5	9539-461-009	Switch-Micro.....	1
12	9545-020-001	Screw 4-40 x 5/8.....	2
*	8640-401-001	Nut Twin.....	1
8	9008-007-001	Actuator-Switch.....	1
9	9451-169-002	Pin Cotter.....	1
13	9039-575-000	Bracket Conduit.....	1
11	9825-057-002	Over-tempcoverass'y.....	1
*	9576-207-006	Thermostatover-tempMnl.....	1
*	9545-008-024	Screw 10B x 3/8.....	2
*	9550-169-003	Shield for macro switch.....	1
17	9834-010-001	Hood Ass'y, Lint.....	1
*	8640-412-004	Nut, Whizlock.....	6
*	9822-031-002	Lint Screen 34" length (newest style).....	1
10	9278-038-004	Impeller, w/set screws.....	1

* Not Illustrated

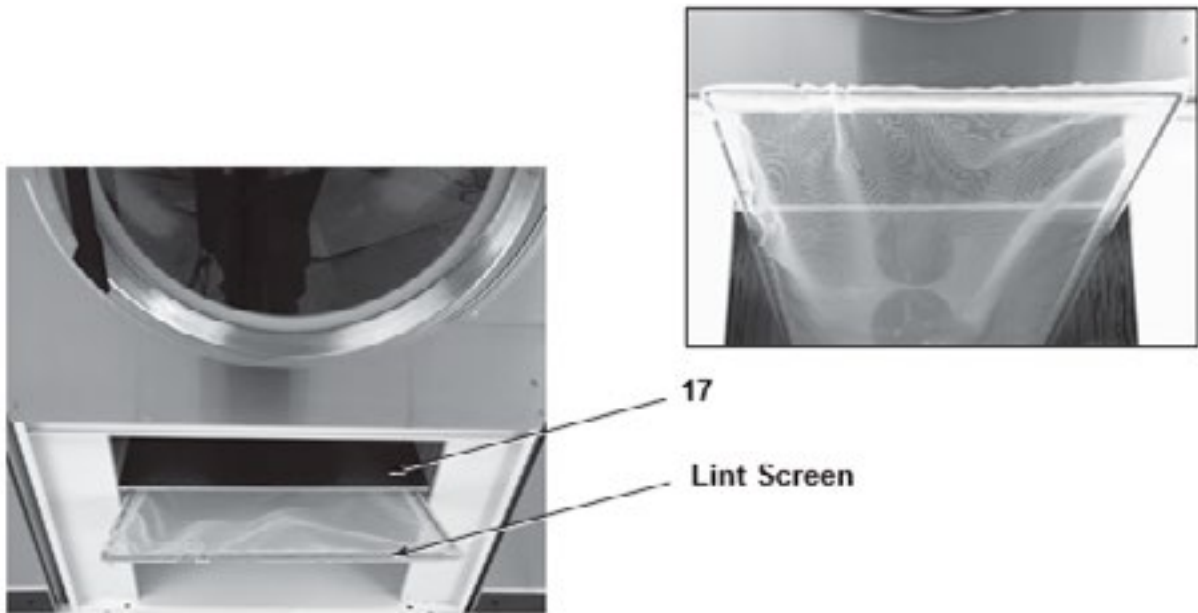

Wire & Harness Group

Key	Part Number	Description	Qty
*	8220-001-486	BRN 26" Air Flow Switch	1
*	8220-001-499	BLK 26" Air Flow Switch	1
*	8220-101-002	BLK 64" Safety Thermostat	1
*	8220-103-003	Wire Assembly GRY 64" Safety Thermostat.....	1
*	8220-101-007	Wire Assembly VIO 54" Hi Limit Thermostat	1
*	8220-101-004	Wire Assembly BRN 54" Hi Limit Thermostat	1
*	2114-008-000	Bushing Anti Short	1
*	8220-001-480	Wire Assembly BLK 45" Door Switch	1
*	8220-001-479	Wire Assembly BLU 45" Door Switch	1
*	8220-001-461	Wire Assembly WHT 58".....	1
*	8220-062-007	Wire Assembly BLK 74".....	1
*	8220-064-012	Wire Assembly RED 61".....	1
*	8220-063-017	Wire Assembly GRY 64".....	1
*	8220-065-021	Wire Assembly VIO 61".....	1
*	8640-276-003	Wire Nut #73 B ORG	1
*	8220-060-001	Wire Assembly GRN 12".....	1
*	8220-063-018	Wire Assembly WHT 8" Control Box.....	1
*	8220-001-230	Wire Assembly BLK/RED 8.5" Control Box	1
*	8220-001-231	Wire Assembly BLK/BLU Control Box	1
*	8220-001-452	Wire Assembly WHT 12" - 4" Control Box	1
*	8220-001-478	Wire Assembly GRN 7" Control Box.....	1
*	8220-067-001	Wire Assembly BLK/RED 7 3/4" Control Box	1
*	8220-067-002	Wire Assembly BLK/BLU 7 3/4" Control Box	1
*	8220-001-466	Wire Assembly Yellow 4 7/8"	1
*	9627-711-001	Low Voltage Harness.....	1
2	9637-403-003	High Voltage Harness.....	1
*	8220-001-290	Wire Assembly BLK.....	1
*	9627-679-002	Wire Harness Heat Sensor.....	1
*	8640-276-005	Wire Nut #71 Black Temp Sensor.....	2
*	8220-106-001	Wire Assy Red 59" - Motor	1
*	8220-106-002	Wire Assy White 59" - Motor	1
*	8220-103-004	Wire Assy Blue 59" - Motor	1

Label Group

Key	Part Number	Description	Qty
*	8507-256-001	Instructions Uncrating.....	1
*	8514-074-001	Owners Booklet	1
*	8507-350-001	Instructions Dry Install / Start-Up.....	1
*	8507-330-001	Instructions TVSS.....	1
*	9345-892-001	Wiring Schematic.....	1
*	9345-891-001	Wiring Diagram.....	1
*	8511-001-002	Label Quality.....	1
*	8502-658-001	Label Fire Hazard	1
*	8527-115-001	Label Decal Lighting and Clearance.....	1
*	8502-645-001	Label Instructions.....	1
*	8502-600-001	Label Warning and Notice	1

Electric Heated Dryers Electrical Parts All Types of KW DCWD 55H__ 18 FD 240/60/3 24 KW

Key	Part Number	Description	Quantity
*	5192-296-001	Relay.....	1
*	5198-213-001	Circuit Breaker 3 Pack.....	2
*	8220-057-016	Wire Assembly Blk.....	3
*	9345-969-001	Schematic.....	1
*	9345-970-001	Diagram	1
*	9870-088-004	Heater Elements 12 KW.....	240 V
2			
*	5192-285-004	Relay.....	1
*	9377-003-001	Variator Coil Supply	1
*	8502-711-001	Warning Label 208V	1
*	8220-057-004	Wire Brown 30".....	1
*	8220-057-007	Wire White/Black 45".....	1
*	8220-057-008	Wire Black 45".....	1
*	8220-057-011	Wire V10 32".....	1
*	8220-057-015	Wire Black 8".....	6
*	8220-057-019	Wire White 8".....	1
*	8220-061-008	Wire Black 36".....	4
*	8220-061-010	Wire Black 48".....	2
*	8220-078-008	Wire Black 9".....	2
*	8220-078-011	Wire White 45".....	1
*	8220-078-012	Wire Red 45".....	1
*	8502-614-004	Label High Voltage.....	1
*	8502-708-001	Label Exhaust Warning.....	1
*	8514-091-001	Owners Book.....	1
*	9029-127-001	Guard Bracket Mounting	1
*	9208-053-001	Guard Front Cabinet Cover	1
*	9208-054-001	Guard Rear Cabinet Cover.....	1
*	9074-289-001	Cover Plate Control Box.....	1
*	9210-117-001	Gussett Control Box.....	1
*	9548-282-001	Support Wire.....	2
*	9074-288-001	Cover Plater Heater	1
*	9636-151-001	Wrapper Heat Housing RH.....	1
*	9636-152-001	Wrapper Heat Housing LH	1
*	9550-181-001	Shield Side Heathousing.....	2
*	9577-056-001	Top Heater Housing Half.....	2
*	9053-067-001	Bushing Insulated 3/4".....	6
*	9577-057-001	Top Box Control.....	1
*	9636-153-001	Wrapper Box Control.....	1
*	9058-025-001	Bottom Box Control.....	1
*	9053-067-004	Bottom Bushing Insulated.....	2
*	9295-004-001	Formed Jumper.....	2
*	9295-005-001	Straight Jumper.....	4
*	9488-010-003	Din Rail 4 3/4".....	1
*	9897-037-001	Power Block 3 Pole.....	1
*	9897-038-001	Power Block 1 Pole.....	1
*	9209-087-001	Grommet	1
*	8640-399-004	Nut Spring.....	1
*	8640-399-009	Nut Spring U Type	4
*	8502-639-001	Label Warning.....	1
*	8502-702-001	Label Warning Fire Hazard (French).....	1
*	8652-134-002	Terminal Lug Solderless	1

Electric Heated Parts Model Specific

DCWD 55H__ 16 FC 208/60/3 24 KW	Key	Part Number	Description	Quantity
*	5198-213-002	Circuit Breaker 3 Pole		2
*	5192-296-001	Relay, Heating Element		1
*	8220-057-016	Wire Assembly Blk 8"		3
*	9870-088-005	Heater Elements 12 KW 208 V		2
*	9345-967-001	Schematic		1
*	9348-968-001	Diagram		1

DCWD 55H__ 16 FE 208/60/3 30 KW	Key	Part Number	Description	Quantity
*	9345-971-001	Schematic		1
*	9345-972-001	Diagram		1
*	5198-213-004	Circuit Breaker 3 Pole		2
*	5192-294-001	Relay, Heating Element		1
*	8220-057-014	Wire Assembly Black 8"		3
*	9870-088-001	Heater Elements 15 KW 208 V		2

DCWD 55H__ 18 FG 240/60/3 30 KW	Key	Part Number	Description	Quantity
*	5192-294-001	Relay, Heating Element		1
*	5198-213-003	Circuit Breaker 3 pole		2
*	8220-057-014	Wire Assembly Black 8"		3
*	9345-973-001	Schematic		1
*	9345-974-001	Diagram		1
*	9870-088-002	Heater Element 15KW 240 V		2

Steam Heated Parts Model Specific

Key	Part Number	Description	Quantity
*	9799-021-001	Steam PCB Assembly Micro	1
*	9805-031-001	Lint Screen Assembly Intake	1
*	9506-032-001	Wire Diagram	1
*	9506-031-001	Wire Schematic	1
*	9488-012-001	Rail Lint Screen Intake	1
*	9379-193-001	Steam Valve Solenoid	1
*	9242-465-001	Braided Steam Hose Stainless	2
*	9089-048-001	Coil Steam Heating	1
*	8514-080-001	Owners Manual	1
*	8502-717-001	Label Lint Screen	1
*	8220-078-017	Wire Assembly White 7"	1
*	8220-078-016	Wire Assembly Red 7"	1
*	8220-067-002	Wire Assembly Black/Blue 7 3/4"	2
*	8220-064-037	Wire Assembly Green 40"	1
*	8220-063-010	Wire Assembly Black/Red 7"	1
*	5192-285-004	Relay	1

