



DEXTER[®]
LAUNDRY

**USE THE BLUE TABS LOCATED ON THE
RIGHT AND LEFT SIDES OF THE FOLLOWING
DOCUMENT TO ADVANCE TO EACH SECTION.**







Dexter Commercial Vended Dryer

C-Series 30Lb, 50Lb, 80Lb, Single Tumbler

Parts & Service Manual

Equipment Safety Warnings Symbols and Terminology Used in this Equipment

	<i>Indicates on</i>
⚠ DANGER	Imminently hazardous situation, which if not avoided, will result in death or serious injury.
⚠ WARNING	Indicates a potentially hazardous situation, which if not avoided could result in death or serious injury.
⚠ CAUTION	Indicates a potentially hazardous situation which, if not avoided, may result in minor or moderate injury. It may also be used to alert against unsafe practices. Minor burns, pinch points that result in bruises and minor chemical irritation.
NOTICE	Indicates information or a company policy that relates directly or indirectly to the safety of personnel or protection of property.
	This is the user caution symbol. It indicates a condition where damage to the equipment resulting in injury to the operator could occur if operational procedures are not followed. TO REDUCE THE RISK OF DAMAGE OR INJURY, refer to accompanying documents; follow all steps or procedures as instructed.
	This is the electrical hazard symbol. It indicates that there are DANGEROUS HIGH VOLTAGES PRESENT inside the enclosure of this product. TO REDUCE THE RISK OF FIRE OR ELECTRIC SHOCK, do not attempt to open the enclosure or gain access to areas where you are not instructed to do so. REFER SERVICING TO QUALIFIED SERVICE PERSONNEL ONLY!
	Caution! There are sharp edges on various sheet metal parts internal to the enclosure. Use safety consciousness when placing or moving your hands while working in the interior of this equipment.
	Caution! To reduce the risk of damage to the Water Inlet Valve, do not supply inlet water with a temperature that exceeds 70° C. Caution! To reduce the risk of fire or explosion, do not operate this equipment in any hazardous classified (ATEX) environment.

Equipment Safety Warnings

Symbols and Terminology Used in this Equipment



Warning! Do not operate equipment if door glass is damaged in any way.



Warning! Keep clear of rotating parts.



Prohibited! Do not enter this equipment or space.



Prohibited! Do not step or stand on this equipment.



Prohibited! Do not operate without all guards and covers in place.



Prohibited! Do not operate without all guards and covers in place.



Prohibited! Do not wash or Dry clothing impregnated with flammable liquids (petrochemical).



Prohibited! Do not allow children to play in or around equipment.

	Indicates an imminently hazardous situation, which if not avoided, will result in death or serious injury.
	Indicates a potentially hazardous situation, which if not avoided could result in death or serious injury.
	Indicates a potentially hazardous situation which, if not avoided, may result in minor or moderate injury. It may also be used to alert against unsafe practices. Minor burns, pinch points that result in bruises and minor chemical irritation.
	Indicates information or a company policy that relates directly or indirectly to the safety of personnel or protection of property.
	This is the user caution symbol. It indicates a condition where damage to the equipment resulting in injury to the operator could occur if operational procedures are not followed. TO REDUCE THE RISK OF DAMAGE OR INJURY, refer to accompanying documents; follow all steps or procedures as instructed.
	This is the electrical hazard symbol. It indicates that there are DANGEROUS HIGH VOLTAGES PRESENT inside the enclosure of this product. TO REDUCE THE RISK OF FIRE OR ELECTRIC SHOCK, do not attempt to open the enclosure or gain access to areas where you are not instructed to do so. REFER SERVICING TO QUALIFIED SERVICE PERSONNEL ONLY
	Caution! To reduce the risk of fire or explosion, do not operate this equipment in any hazardous classified (ATEX) environment.



WARNING

	<ul style="list-style-type: none"> • All Dryers must be installed in accordance to all applicable electrical, plumbing and all other local codes. • These installation and operation instructions are for use by qualified personnel only. To avoid injury and electrical shock, do not perform any servicing other than that contained in the installation and operation instructions, unless qualified.
	Do not install Equipment in an explosive atmosphere.
	<ul style="list-style-type: none"> • Care must be stressed with all foundation work to ensure a stable unit installation, eliminating possibilities of excessive vibration. • Foundation must be level within 13 mm to ensure proper washer operation.
	Do not operate washer or Dryer if door glass is damaged in any way.
	Do not wash or Dry clothing impregnated with flammable liquids (petrochemical).



WARNING





 	Children should be supervised to ensure they do not operate or play in or around equipment.
	Keep all panels in place to protect against electrical shock and injury and add rigidity to washer.

This appliance is not intended for use by persons (including children) with reduced physical, sensory or mental capabilities, or lack of experience and knowledge, unless they have been given supervision or instruction concerning use of the appliance by a person responsible for their safety.

A washer should not be allowed to operate if any of the following occur:

- Excessive high water level.
- Machine is not connected to a properly earthed circuit.
- Door does not remain securely locked during the entire cycle.
- Vibration or shaking from an inadequate mounting or foundation.

	Warning! Do not operate equipment if door glass is damaged in any way.
	Warning! Keep clear of rotating parts.
	Prohibited! Do not enter this equipment or space.
	Prohibited! Do not step or stand on this equipment.
	Prohibited! Do not operate without all guards and covers in place.
	Prohibited! Do not operate without all guards and covers in place.
	Prohibited! Do not wash or Dry clothing impregnated with flammable liquids (petrochemical).
	Prohibited! Do not allow children to play in or around equipment.

	Prohibited! Do not attempt to open, touch, or proceed before referring to the manual or unless qualified.
	Mandatory! Read all supporting documentation before operating or maintaining equipment.
	Mandatory! Disconnect power before servicing equipment.
	Mandatory! Lock out and tag out before servicing this equipment.
	Mandatory! Children should be supervised to ensure they do not operate equipment.

Section 1:

Dryer

Specifications & Installation

Machine Specifications: 30Lb

30 lb. Commercial Dryer: T-30 – DC0030NB-10EC1X (60 Hz), DC0030NB-39AC1X (50 Hz)

Cabinet Height	72 1/4"	1835 mm.
(Assumes minimum leveling leg adjustment)		
Cabinet Width	31 1/2"	800 mm.
Overall Depth	42"	1067 mm.
Floor to Door Center	41 1/4"	1048 mm.
Door Opening	22 5/8"	575 mm.
Dry Wt. Capacity	30 Lbs.	13.6 kg.
Cylinder Diameter	30"	762 mm.
Cylinder Depth	27 1/2"	699 mm.
Cylinder Volume	11.25 cu. ft.	319 liters
Lint Screen Area	515 sq. in.	3323 sq. cm.
Gas Input (60 hz)	90,000 Btu/hr	26.4 kW
Gas Input (50 hz)	72,000 Btu/hr	21.1 kW
Gas Supply Connection	1/2"	12.7 mm.
Natural Gas Supply (Water Column)	5-8"	127 mm. - 203 mm.
Natural Burner Manifold	3 1/2"	88.9 mm.
L.P. Supply (Water Column)	11 1/2 -14"	292 mm. - 356 mm.
L.P. Burner Manifold	11"	279 mm.
Exhaust Size	8"	203 mm.
Make-up Air	1.0 sq. ft.	929 sq. cm.
Example: 1.0 sq. ft. = 1 ft. long X 1 ft. wide		
Motor Size	1/2 H.P.	.373 kW
Airflow (60 hz)	830 CFM	23.5 m ³ /min
Airflow (50 hz)	690 CFM	19.5 m ³ /min

Electrical Specifications - 120/60/1

Voltage/Hz/Phase 120VAC/60Hz/1Phase		
Running Amps	9.6	
Circuit Protection Amps	15	
Wire Size	12 gauge	
Electrical Service	2 wire + ground	

Electrical Specifications - 220-240/50/1

Voltage/Hz/Phase 220-240VAC/50Hz/1Phase		
Running Amps	5.1	
Circuit Protection Amps	10	
Wire Size	14 gauge	
Electrical Service	2 wire + ground	

Shipping Weight	507 Lbs.	231 kg.
Net Weight	463 Lbs.	210 kg.
Clearance Behind Machines (min.)	18"	457 mm.

Machine Dimensions: 30Lb

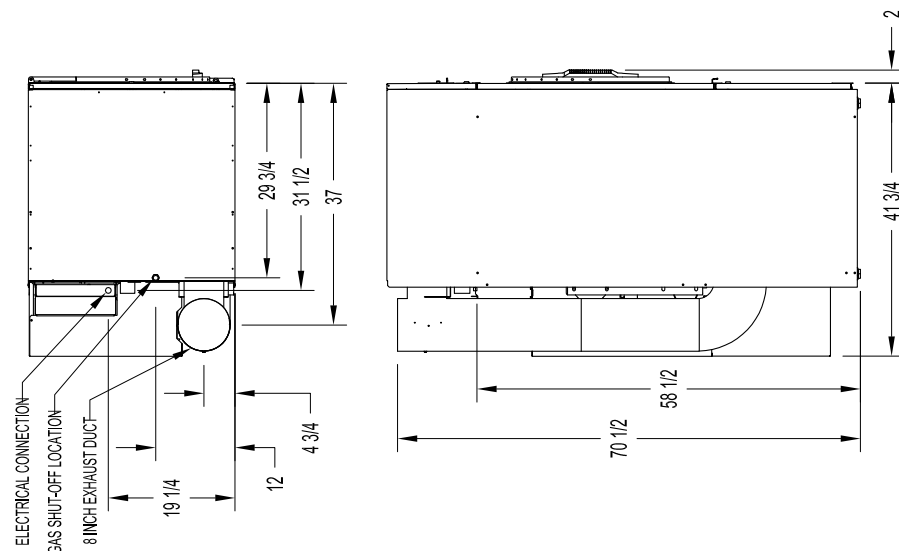
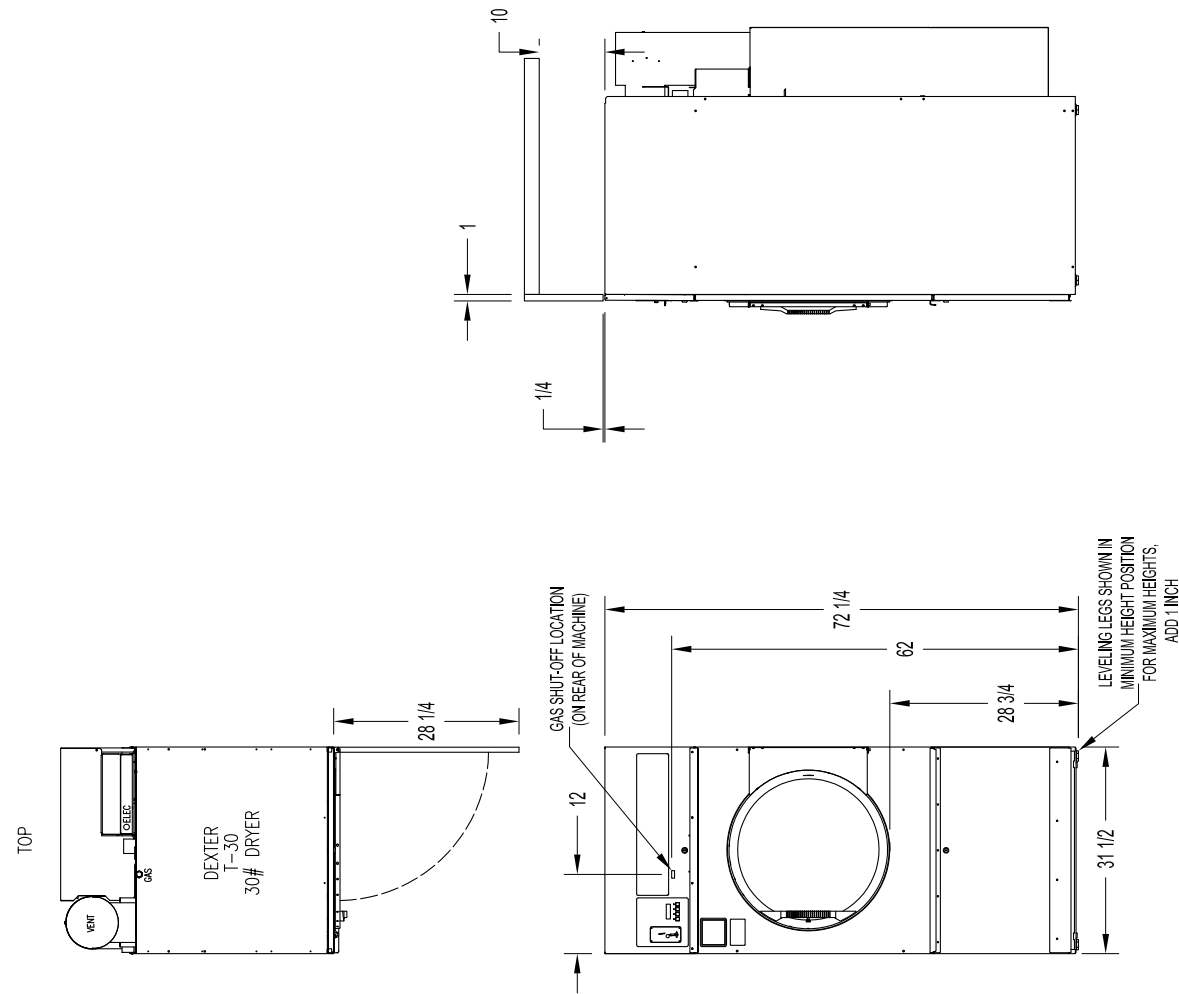

Machine Specifications: 50Lb

50 lb. Commercial Dryer: T-50 – DC0050NB-10EC1X (60 Hz), DC0050NB-39AC1X (50 Hz)

Cabinet Height	72 1/4"	1835 mm.
(Assumes minimum leveling leg adjustment)		
Cabinet Width	34 1/2"	875 mm.
Overall Depth	48"	1219 mm.
Floor to Door Center	41"	1041 mm.
Door Opening	25 5/8"	653 mm.
Dry Wt. Capacity	50 Lbs.	24.9 kg.
Cylinder Diameter	32.5"	826 mm.
Cylinder Depth	33"	845 mm.
Cylinder Volume	15.84 cu. ft.	449.5 liters
Lint Screen Area	708 sq. in.	4568 sq. cm.
Gas Input (60 hz)	145,000 Btu/hr	42.5 kW
Gas Input (50 hz)	120,000 Btu/hr	35.2 kW
Gas Supply Connection	1/2"	12.7 mm.
Natural Gas Supply (Water Column)	5-8"	127 mm. - 203 mm.
Natural Burner Manifold	3 1/2"	88.9 mm.
L.P. Supply (Water Column)	11 1/2 -14"	292 mm. - 356 mm.
L.P. Burner Manifold	11"	279 mm.
Exhaust Size	8"	203 mm.
Make-up Air	1.25 sq. ft.	1161 sq. cm.
Example: 1.25 sq. ft. = 1.25 ft. long X 1 ft. wide		
Motor Size (60 Hz)	1 H.P.	.746 kW
Motor Size (50 Hz)	3/4 H.P.	.560 kW
Airflow (60 hz)	910 CFM	25.8 m ³ /min
Airflow (50 hz)	760 CFM	21.5 m ³ /min

Electrical Specifications - 120/60/1

Voltage/Hz/Phase	120VAC/60Hz/1Phase
Running Amps	9.6
Circuit Protection Amps	15
Wire Size	12 gauge
Electrical Service	2 wire + ground

Electrical Specifications - 220-240/50/1

Voltage/Hz/Phase	220-240VAC/50Hz/1Phase
Running Amps	5.1
Circuit Protection Amps	10
Wire Size	14 gauge
Electrical Service	2 wire + ground

Shipping Weight	611 Lbs.	277 kg.
Net Weight	579 Lbs.	263 kg.
Clearance Behind Machines (min.)	18"	457 mm

Machine Dimensions: 50Lb

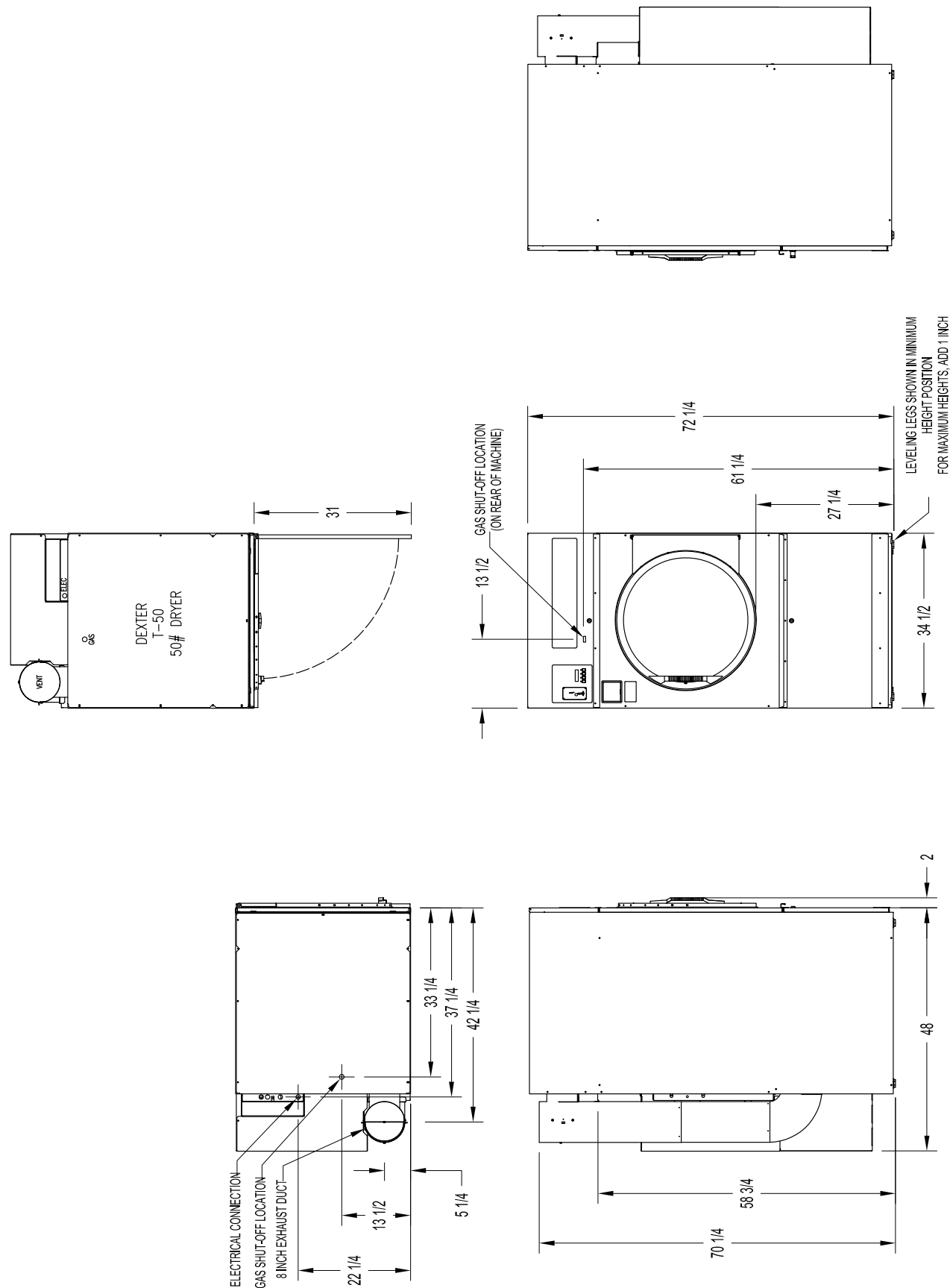

Machine Specifications: 80Lb

80 lb. Commercial Dryer: T-80 – DC0080NB-10EC1X (60 Hz), DC0080NB-39AC1X (50 Hz)

Cabinet Height	75 3/4"	1924 mm.
(Assumes minimum leveling leg adjustment)		
Cabinet Width	38 3/8"	975 mm.
Overall Depth	51 3/4"	1315 mm.
Floor to Door Center	43"	1092 mm.
Door Opening	25 5/8"	653 mm.
Dry Wt. Capacity	80 Lbs.	36.3 kg.
Cylinder Diameter	36.5"	927 mm.
Cylinder Depth	38"	965 mm.
Cylinder Volume	23.0 cu. ft.	651.3 liters
Lint Screen Area	823 sq. in.	5310 sq. cm.
Gas Input (60 hz)	215,000 Btu/hr	63.0 kW
Gas Input (50 hz)	195,000 Btu/hr	57.1 kW
Gas Supply Connection	1/2"	12.7 mm.
Natural Gas Supply (Water Column)	5-8"	127 mm. - 203 mm.
Natural Burner Manifold	3 1/2"	88.9 mm.
L.P. Supply (Water Column)	11 1/2 -14"	292 mm. - 356 mm.
L.P. Burner Manifold	11"	279 mm.
Exhaust Size	8"	203 mm.
Make-up Air	1.5 sq. ft.	1394 sq. cm.
Example: 1.5 sq. ft. = 1.5 ft. long X 1 ft. wide		
Motor Size (60 Hz)	1 H.P.	.746 kW
Motor Size (50 Hz)	3/4 H.P.	.560 kW
Airflow (60 hz)	1200 CFM	34.0 m ³ /min
Airflow (50 hz)	1000 CFM	28.3 m ³ /min

Electrical Specifications - 120/60/1

Voltage/Hz/Phase	120VAC/60Hz/1Phase
Running Amps	10.4
Circuit Protection Amps	15
Wire Size	12 gauge
Electrical Service	2 wire + ground

Electrical Specifications - 220-240/50/1

Voltage/Hz/Phase	220-240VAC/50Hz/1Phase
Running Amps	5.2
Circuit Protection Amps	10
Wire Size	14 gauge
Electrical Service	2 wire + ground

Shipping Weight	729 Lbs.	331.2 kg.
Net Weight	699 Lbs.	291.2 kg.
Clearance Behind Machines (min.)	18"	457 mm.

Machine Dimensions: 80Lb

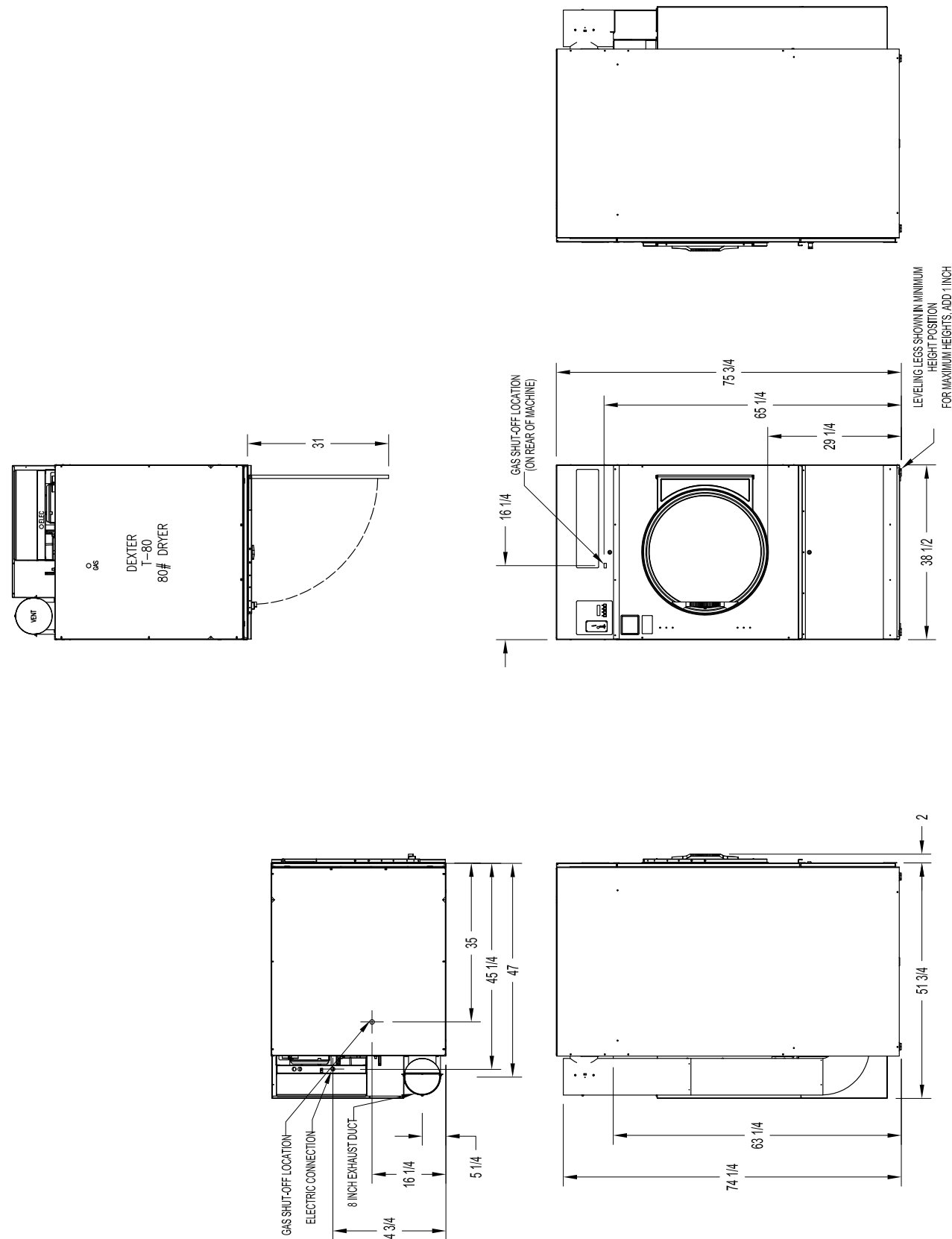

Dryer Installation

All commercial dryer installations must conform with local applicable local codes or in the absence of local codes, with the National Fuel Gas Code ANSI Z223.1A-1988. Canadian installations must comply with current standard CAN/CGA-B149(.1 or .2) Installation Code for Gas Burning Appliances or Equipment, and local codes if applicable. The appliance, when installed, must be electrically grounded in accordance with the National Electric Code, ANSI/NFPA No. 70-1990, or when installed in Canada, with Standard CSA C22.1 Canadian Electrical Code Part 1.

Installation Clearances:

This unit may be installed at the following alcove clearances. (Millimeters)

1. Left side- 0"
2. Right side- 0" *
3. Back- 18" (457) (Certified for 1" (25) clearance; however, 18" (457) clearance is necessary behind the belt guard to allow servicing and maintenance.)
4. Front- 48" (1220) (to allow use of dryer)
5. Top- Refer to figure labelled "Vertical Clearance Dimensions". Certification allows 0" clearance at the top 1" (25) back from the front. However, a 1/4" (6) clearance is required to allow opening the upper service door. A 10" (254) clearance is required from the top at all other points.
6. Floor- This unit may be installed upon a combustible floor. *Units may be installed in direct contact with an adjacent dryer, providing allowance is made for opening upper and lower service doors. Do not obstruct the flow of combustion and ventilation air. Maintain minimum of 1" (25) clearance between duct and combustible material.

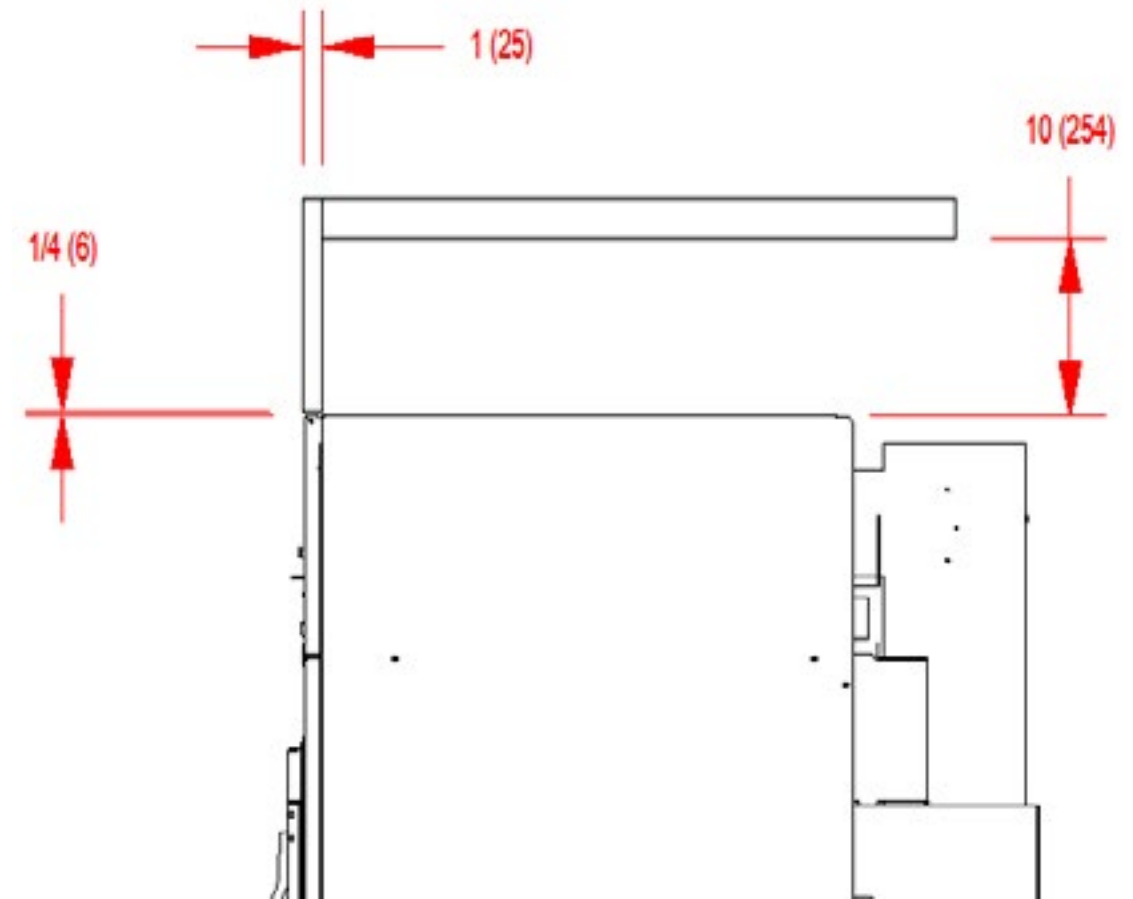

VERTICAL CLEARANCE DIMENSIONS - ALL C Series (30/50/80)

MAKE-UP AIR

Adequate make-up air must be supplied to replace air exhausted by dryers on all types of installations. Provide a minimum make-up air opening to the outside for each dryer as follows:

Dryer Model	Make-up Air Volume/Time	Make-up Air Opening Area (minimum)
DC0030NC-10EC1X	830 CFM (23.5 m3/minute)	1 ft ² (0.10 m ²)
DC0030NC-39AC1X	690 CFM (19.5 m3/minute)	1 ft ² (0.10 m ²)
DC0050NC-10EC1X	910 CFM (25.8 m3/minute)	1.25 ft ² (0.12 m ²)
DC0050NC-39AC1X	760 CFM (21.5m3/minute)	1.25 ft ² (0.12 m ²)
DC0080NC-10EC1X	1200 CFM (34.0 m3/minute)	1.5 ft ² (0.14 m ²)
DC0080NC-39AC1X	1000 CFM (28.3 m3/minute)	1.5 ft ² (0.14 m ²)

This is a net requirement of effective area. Screens, grills or louvers, which will restrict the flow of air, must be considered. Consult the supplier to determine the free area equivalent for the grill being used. The source of make-up air should be located sufficiently away from the dryers to allow an even airflow to the air intakes of all dryers. Multiple openings should be provided.

NOTE: The following considerations must be observed for gas dryer installations where dry cleaners are installed. The sources of all make-up air and room ventilation air movement to all dryers must be located away from any dry cleaners. This is necessary so that solvent vapors will not be drawn into the dryer inlet ducts. Dry cleaner solvent vapors will decompose in contact with an open flame such as the gas flame present in clothes dryers. The decomposition products are highly corrosive and will cause damage to the dryer(s), ducts and clothes loads.

ELECTRICAL REQUIREMENTS.

The electrical power requirements necessary to operate the unit satisfactorily are listed on the serial plate located on the back panel of each dryer. The electrical connection should be made to the terminal block in the rear control box assembly on the rear of the unit, using a wire size adequate to handle the amperage and voltage listed on the serial plate, but never smaller than No.12 AWG wire. It is absolutely necessary that the dryer be grounded to a known ground.

Individual circuit breakers for each unit are recommended. The wiring diagram is located on the belt guard on the back of the machine.

TRANSIENT VOLTAGE SURGE SUPPRESSORS

Like most electrical equipment your new machine can be damaged or have its life shortened by voltage surges due to lightning strikes which are not covered by factory warranty. Local power distribution problems also can be detrimental to the life of electrical components. We recommend the installation of transient voltage surge suppressors for your new equipment. These devices may be placed at the power supply panel for the complete installation and don't require an individual device for each machine.

These surge protectors help to protect equipment from large spikes and also from small ongoing spikes in the power that occur on a day to day basis. These smaller surges can shorten overall life of electrical components of all types and cause their failure at a later date. Although they can't protect against all events, these protective devices have a good reputation for significantly lengthening the useful life of electronic components.

Electronic Components are helped to have a longer useful life when they are supplied with the clean stable electrical power they like.

We are including the following names and links to a few suppliers of these devices for those who don't currently have a source.

TVSS

MANUFACTURERS

Innovative Technology, Inc

CONTACT

(Eaton) Factory

PHONE

1-800-647-8877 or www.itvss.com

EFI Electronics Corporation
(Schneider Electric)

Factory
Distributor – Surge Pro

1-800-877-1174 or www.efinet.com
1-877-233-0153

MCG Surge Protection

Factory

1-800-851-1508 or www.mcgsurge.com

Advanced Protection
Technologies Inc.

Factory

1-800-237-4567 or www.aptsurge.com

GAS REQUIREMENTS.

The complete gas requirements necessary to operate the dryer satisfactorily are listed on the serial plate located on the back panel of the dryer. The inlet gas connection to the unit is 1/2 inch pipe thread. A joint compound resistant to the action of liquefied petroleum gases should be employed in making pipe connections. A 1/8 inch NPT plugged tapping, accessible for test gage connection, must be installed immediately upstream of the gas supply connection to the dryer. A drip tee should be provided in the gas piping entering the unit to catch dirt and other foreign articles. All pipe connections should be checked for leakage with soap solution. Never check with an open flame. For altitudes above 2,000 feet (610m) it is necessary to derate the BTU input. Contact your local distributor for instructions. L.P. gas conversion kits are available for this dryer. Contact your local distributor.

CAUTION: The dryer and its individual shutoff valve must be disconnected from the gas supply piping system during any pressure testing of that system at test pressures in excess of 1/2 psig. The dryer must be isolated from the gas supply piping system by closing its individual manual shutoff valve during any pressure testing of the gas supply piping system at test pressures equal to or less than 1/2 psig.

Burner Set-Up

All gas burner manifolds should be checked for proper gas pressure while burning. Dryer manifold pressure should be set at 3.5 W.C. for Natural Gas while burner operating.

EXHAUST INSTALLATION. (Refer to Figure 2 at the end of section 6.) Exhausting of the dryer(s) should be planned and constructed so that no air restrictions occur. Any restriction due to pipe size or type of installation can cause slow drying time, excessive heat, and lint in the room.

From an operational standpoint, incorrect or inadequate exhausting can cause a cycling of the high limit thermostat which shuts off the main burners and results in inefficient drying.

Individual exhausting of the dryers is recommended. All heat, moisture, and lint should be exhausted outside by attaching a pipe of the proper diameter to the dryer adapter collar and extending it out through an outside wall.

This pipe must be very smooth on the inside, as rough surfaces tend to collect lint which will eventually clog the duct and prevent the dryer from exhausting properly. All elbows must be smooth on the inside. All joints must be made so the exhaust end of one pipe is inside the next one downstream. The addition of an exhaust pipe tends to reduce the amount of air the blower can exhaust. This does not affect the dryer operation if held within practical limits. For the most efficient operation, it is recommended that no more than 20' (6m) of straight 8" diameter pipe be used with two right angle elbows. When more than two elbows are used, 2' (600mm) of straight pipe should be removed for each additional elbow. No more than four right angle elbows should be used to exhaust a dryer.

Maintain minimum 1" (25) clearance between duct and combustible material.

If the exhaust pipe passes through a wall, a metal sleeve of slightly larger diameter should be set in the wall and the exhaust pipe passed through this sleeve. This practice is required by some local codes and is recommended in all cases to protect the wall. This type of installation should have a means provided to prevent rain and high winds from entering the exhaust when the dryer is not in use. A hood with a hinged damper can be used for this purpose. Another method would be to point the outlet end of the pipe downward to prevent entrance of wind and rain. In either case, the outlet should be kept clear, by at least 24" (610), of any objects which would cause an air restriction.

Never install a protective screen over the exhaust outlet. When exhausting a dryer straight up through a roof, the overall length of the duct has the same limits as exhausting through a wall. A rain cap must be placed on top of the exhaust and must be of such a type as to be free from clogging. The type using a cone shaped "roof" over the pipe is suitable for this application.

Exhausting the dryer into a chimney or under a building is not permitted. In either case there is a danger of lint build-up which can be highly combustible.

Installation of several dryers, where a main discharge duct is necessary, will need the following considerations for installation (see Fig. 2). Individual 8" (200mm) ducts from the dryers into the main discharge duct should be at a 45 degree angle in the direction of discharge air flow.

NOTE: Never install the individual 8" ducts at a right angle into the main discharge duct. The individual ducts from the dryers can enter at the sides or bottom of the main discharge duct. Figure 2 indicates the various round main duct diameter to use with the individual dryer ducts. The main duct can be rectangular or round, provided adequate air flow is maintained. For each individual dryer, the total exhausting (main discharge duct plus duct outlet from the dryer) should not exceed the equivalent of 20 feet (6m) and two elbows. The diameter of the main discharge duct at the last dryer must be maintained to exhaust end.

NOTE: A small diameter duct will restrict air flow; a large diameter duct will reduce air velocity – both contributing to lint build up. An inspection door should be provided for periodic clean-out of the main duct.

NOTE: STATIC BACK PRESSURE should be a maximum of 0.3 in. w.c (7.6 mm w.c) at the rear exhaust outlet of the dryer. If multiple dryers are connected to the common duct, ensure the back draft damper is installed properly.

NOTE: The following illustration shows the various round main duct diameters to use with the individual dryer ducts. The main duct can be rectangular or round, provided adequate air flow is maintained. For each individual cylinder the total exhausting (main discharge duct plus duct outlet from the dryer) should not exceed the equivalent of 14 feet and two elbows. The diameter of the main discharge duct at the last dryer must be maintained to exhaust end.

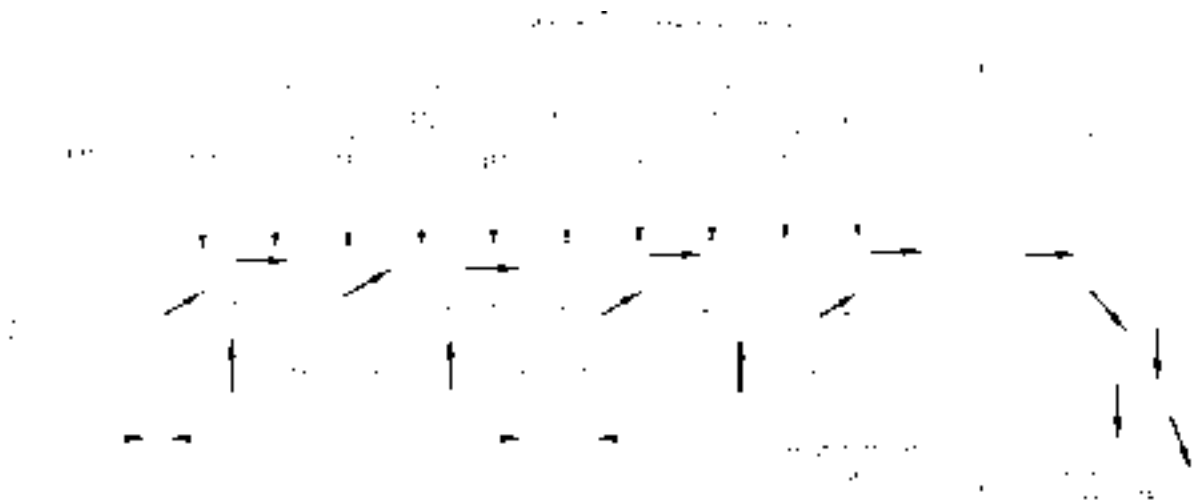

DRYER IGNITION (SOLID STATE IGNITION).

The solid state ignition system lights the main burner gas by spark. The gas is ignited and burns only when the gas-valve relay (in the electronic controller) calls for heat. The procedure for first-time starting of a dryer is as follows:

- A. First, review and comply with the "WARNINGS ABOUT USE AND OPERATION" found on the inside front cover of this manual. Be sure the electrical power supply is connected correctly. The white (neutral) wire is to be connected to the N terminal while the black (line) wire to the L1 terminal of the terminal block in the rear control box. The dryer MUST be properly grounded.
- B. Make sure all gas supply lines are purged of air. Close the main gas shut-off valve and wait for five minutes before turning the valve back on.
- C. Turn on main electrical power switch. The dryer may be started by following the "OPERATING INSTRUCTIONS" found later in this manual.
- D. Natural gas and liquefied petroleum gas fired dryers both operate in the same manner. When gas-valve relay contacts are closed (indicating a demand for heat), the solid state ignition control will automatically supply energy to the redundant gas valve. Spark will continue until a flame is detected by the sensing probe, but not longer than 10 seconds. If the gas fails to ignite within 10 seconds, the gas will shut off for 15 seconds. The control will attempt to ignite two more times in a similar manner. If the gas fails to ignite after three tries, the gas valve closes and the system will "lock out". No further attempts at ignition will be performed automatically. It is then necessary to interrupt electrical power to the ignition system before making another attempt to light the burners. This can be done by opening the dryer door, allowing the dryer to come to a stop for 15 seconds, closing the door, and pushing the "Start" button. The dryer will then repeat the ignition trial cycle.

DRYER SHUTDOWN

To render the dryer inoperative, turn off the main gas shut-off valve and disconnect electrical power to the dryer.

IT IS RECOMMENDED THAT THE INSTALLER TEST THE DRYER FOR OPERATION AND INSTRUCT THE USER BEFORE LEAVING THE INSTALLATION.

Section 2: Dryer Operating Instructions

OPERATING INSTRUCTIONS

STARTING THE DRYER

1. The display on the dryer control will show the required vend amount when in idle mode. Once the door is opened it will prompt the user to add money. Load clothes into the dryer. Close the door completely.
2. Deposit coins equal to or greater than the displayed vend price. The display on the control will prompt the user to choose a drying temperature.
3. Select the drying temperature by pressing the appropriate button for "high", "med" (medium) or "low". This will turn on the red indicator light showing the selected temperature.
4. Press the "start" button to start dryer. This will turn on the green indicator Light. The drying time purchased is now displayed. The colon begins flashing to indicate that the timer is counting down.



Section 3:

Dryer Programming Instructions

DexterLive

The new DexterLive controls were created for you to be able to interface easier with your equipment and create variable pricing cycles to increase your profitability in the same floor space.

First, log into DexterLive, create your location and equipment list and then create your cycle and pricing information by the particular type of washer and dryer at the location. Once the information is saved, download the "AllUser.xml" file to a USB device which will be used to program the machines from the USB port.

Keep it simple or use the marketing features such as temperature pricing, plus cycle or an additional final rinse that the customer can select for a value added wash. Utilize time of day pricing to help move people from heavy use periods to special value times of day or days of the week.

Through the easy to use USB programming so you can download all special pricing and cycles from DexterLive to set up your store quickly and easily.



Accessible

Available anytime, anywhere, on any internet capable device. Once you have set up your free account all of your custom settings and store information are saved making it quick and easy to make future changes.

Simple

View and customize equipment settings to fit your business model. Download your unique user file and quickly transfer it to your equipment via USB.

Profitable

Create exciting promotions to attract new customers. Offer extra prewash, plus cycles, Extra rinse and temperature pricing to drive more revenue in your store.

First Time Creating an Account at Dexter Live

- 1) Log into DexterLive
At the bottom, select "Create your DexterLive account."

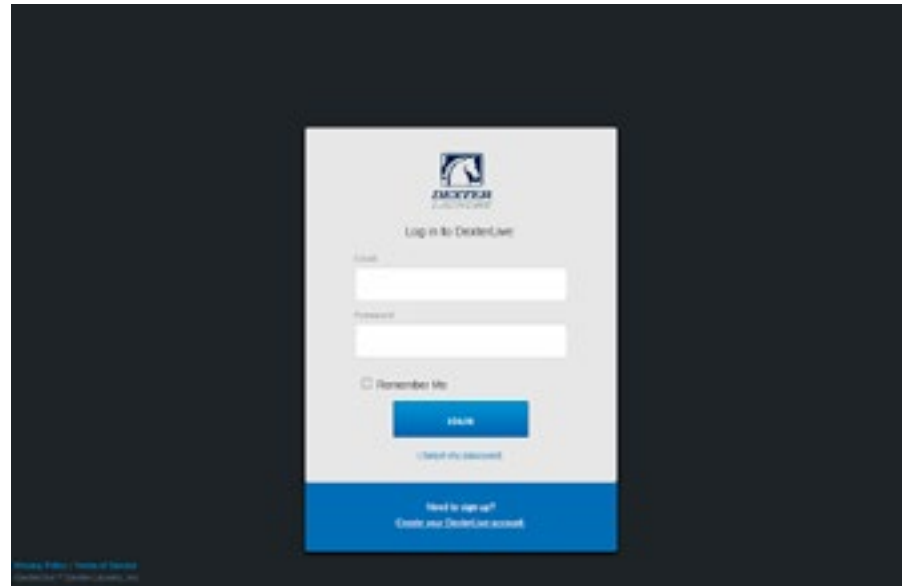

DexterLive gives an owner the ability to manage multiple locations.

- 2) At the "Create a DexterLive Account" screen.
 - A. First time users must create an account.

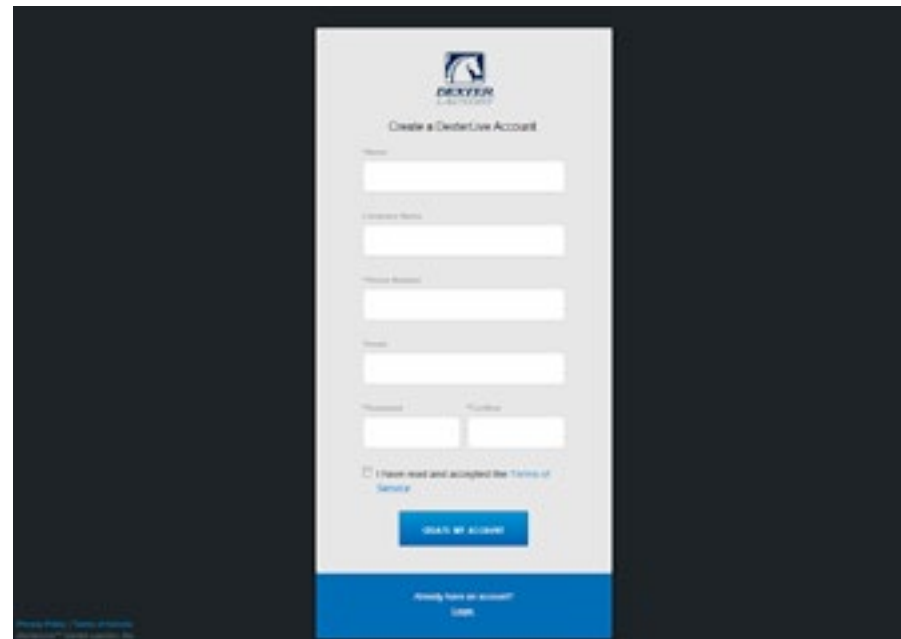

An account must be created to use the DexterLive features.

- B. Fill in the required fields and click on "Create My Account".

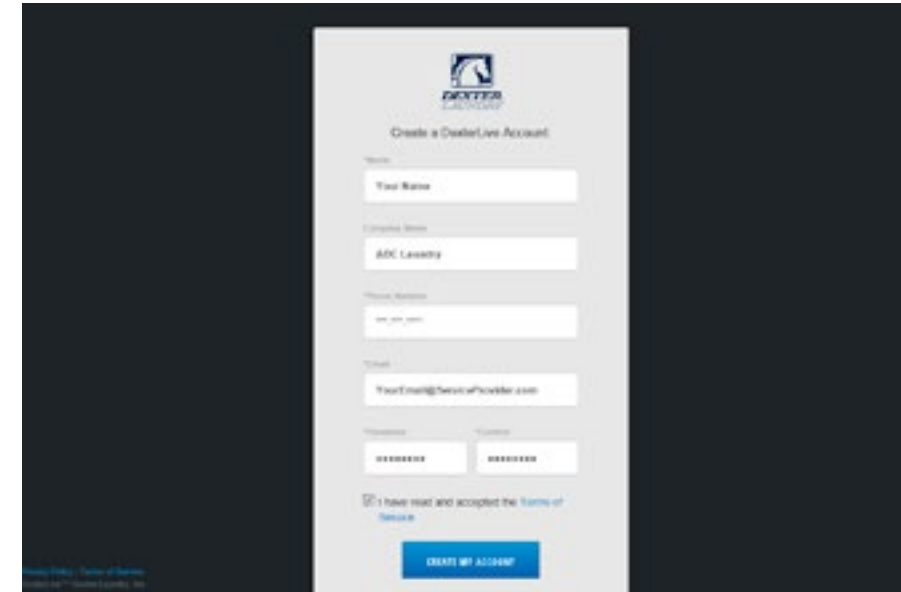

When creating a new user account make sure to fill in all fields marked with asterisks and check the "Terms of Service" box.

- C. After selecting to "Create My Account", you will see the log in screen advising you to go to your e-mail and activate your account.

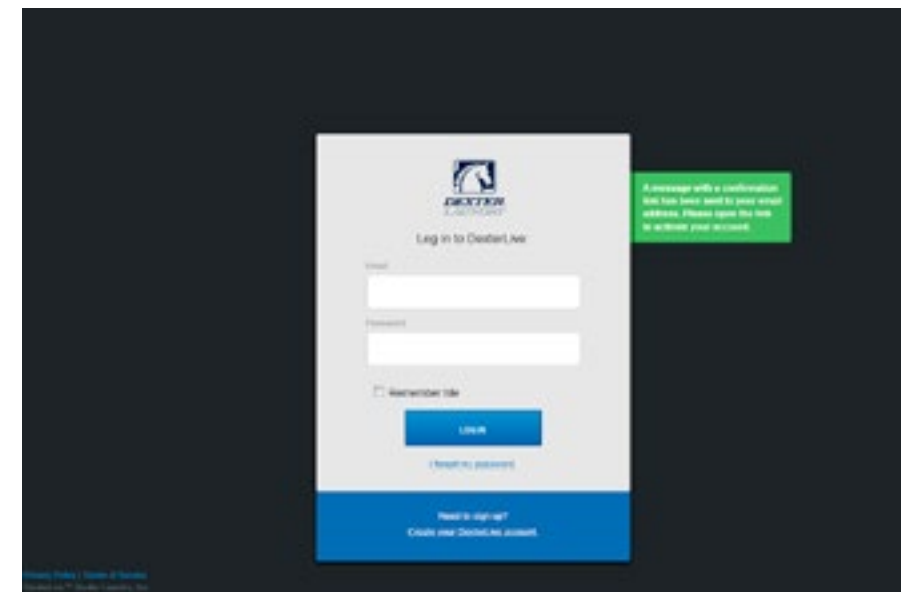

After creating your account you will need to use the e-mail link to gain first access. The account will not be active until you confirm your account.

- 3) Open the e-mail sent from Dexterlive and select "CONFIRM MY ACCOUNT".

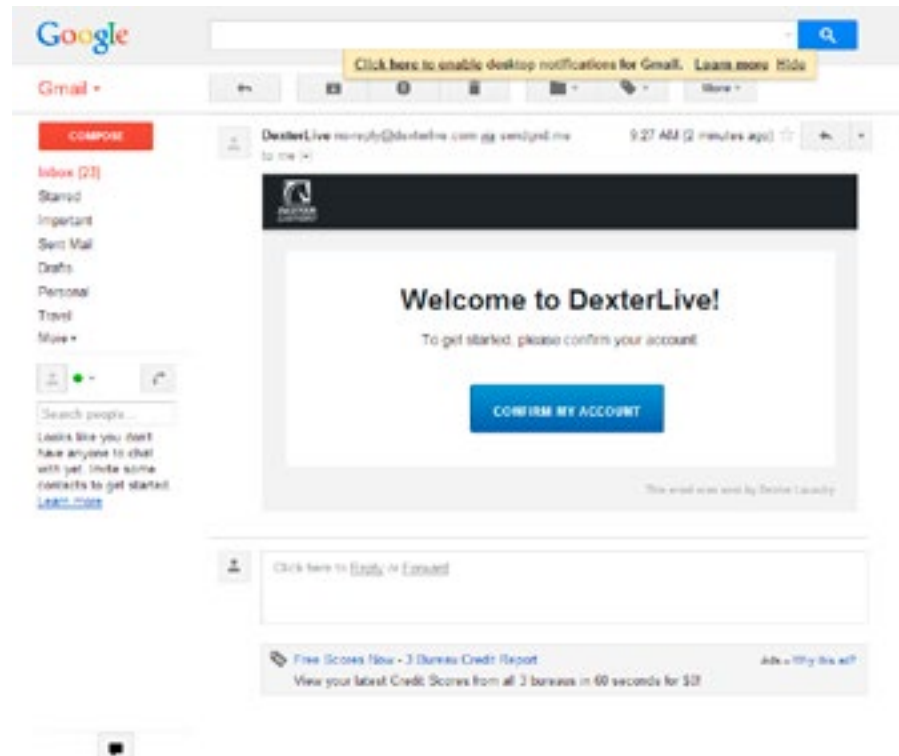

Selecting the "Confirm My Account" hyperlink will take you back to the DexterLive log in page.

- 4) At the "Log into DexterLive" screen, enter your e-mail/user name and password to access DexterLive.

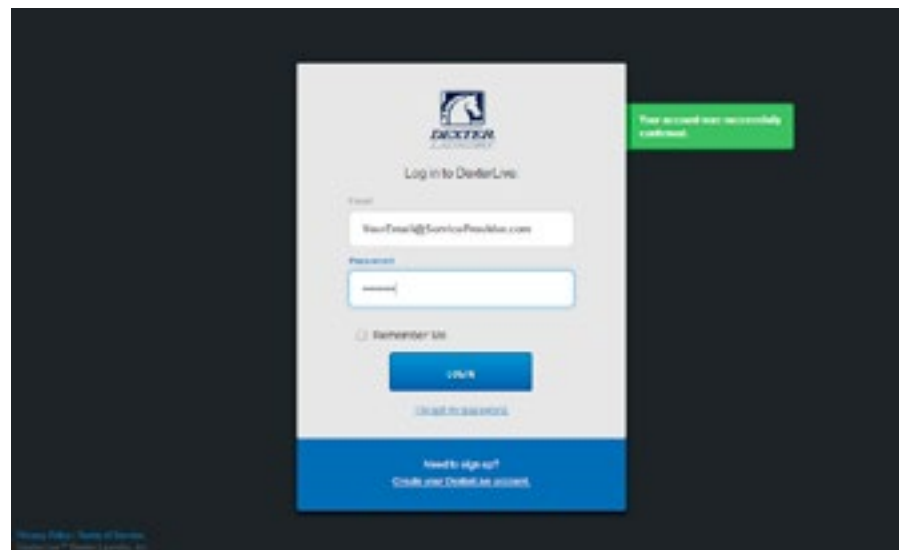

Welcome to DexterLive. Proceed to the step to create your location information.

Programming

- 5) To configure your settings with DexterLive.com:
 A. Add or select a location to program.

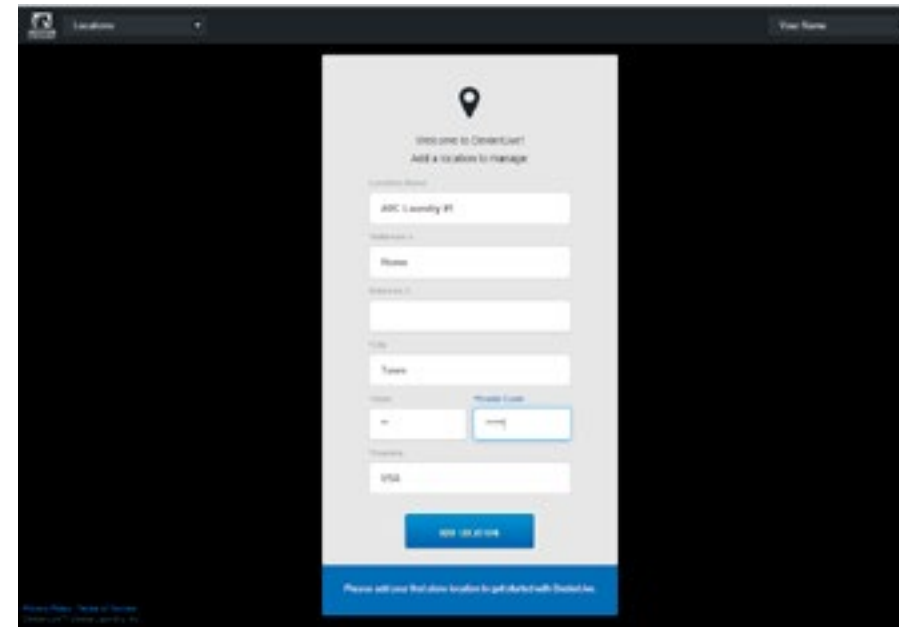

DexterLive gives an owner the ability to manage multiple locations and machines.

- B. On the left side of the screen, select the "Programming" tab.

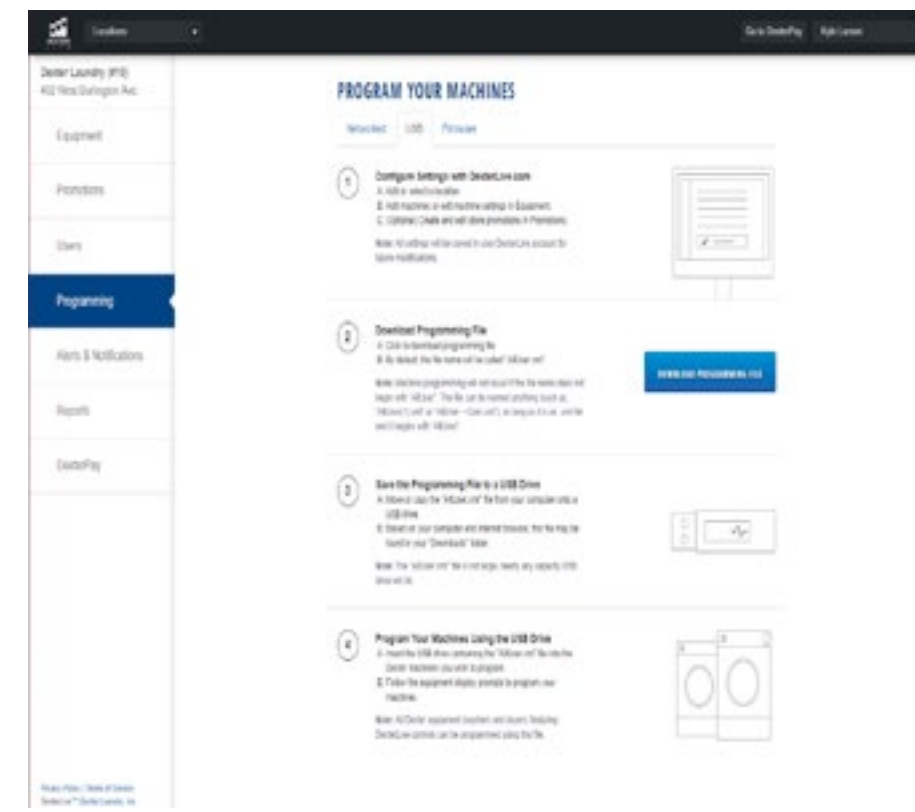

Follow instructions in the programming tab.

C. Edit the "General Settings" (Equipment Tab).

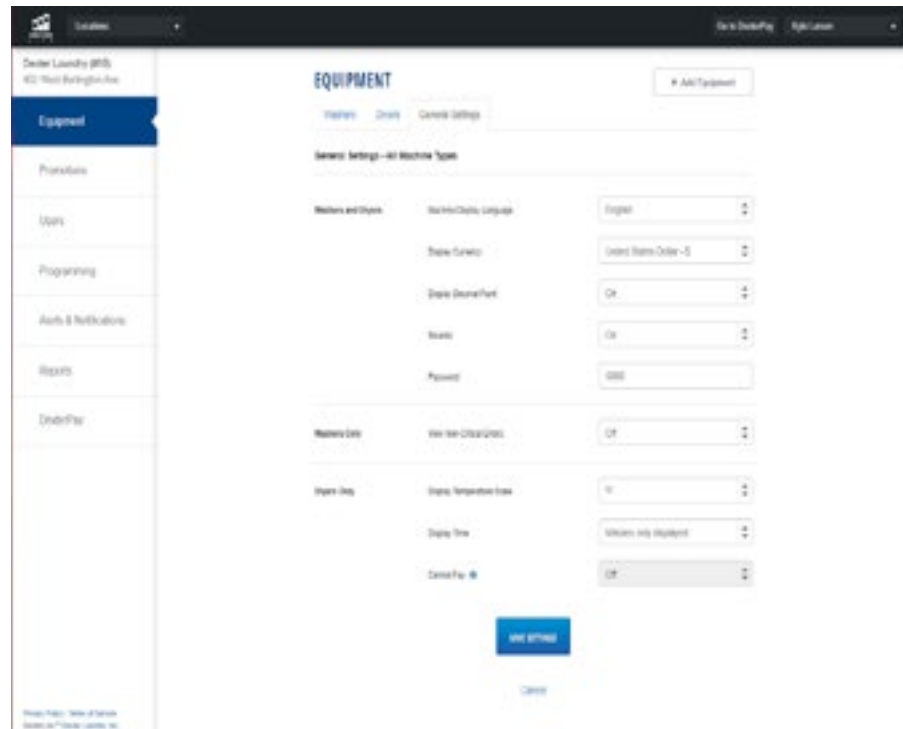

Adjust setting and offset time to match your location. (Time is set for Central Standard Time)

D. Next select the "+Add Equipment" (Equipment Tab), located in the upper right hand corner.

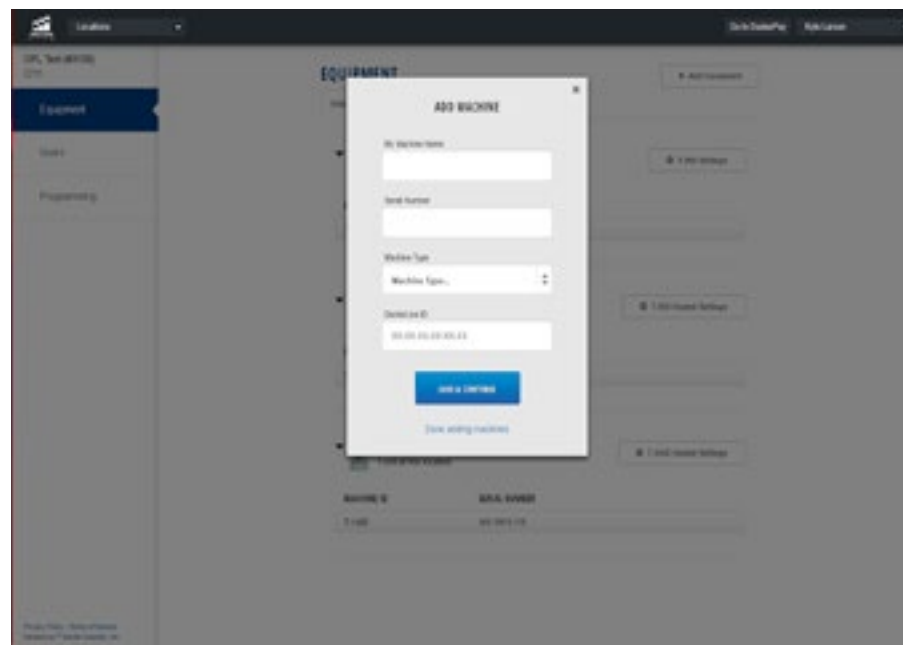

Name of the machine. (Example: Dryer 1) Enter serial number and machine type then select "Save and Continue."

E. When all of the equipment has been added, select "Edit" on the machine type you wish to modify, and then select "Pricing". (Equipment Tab and Machine Settings Tab)

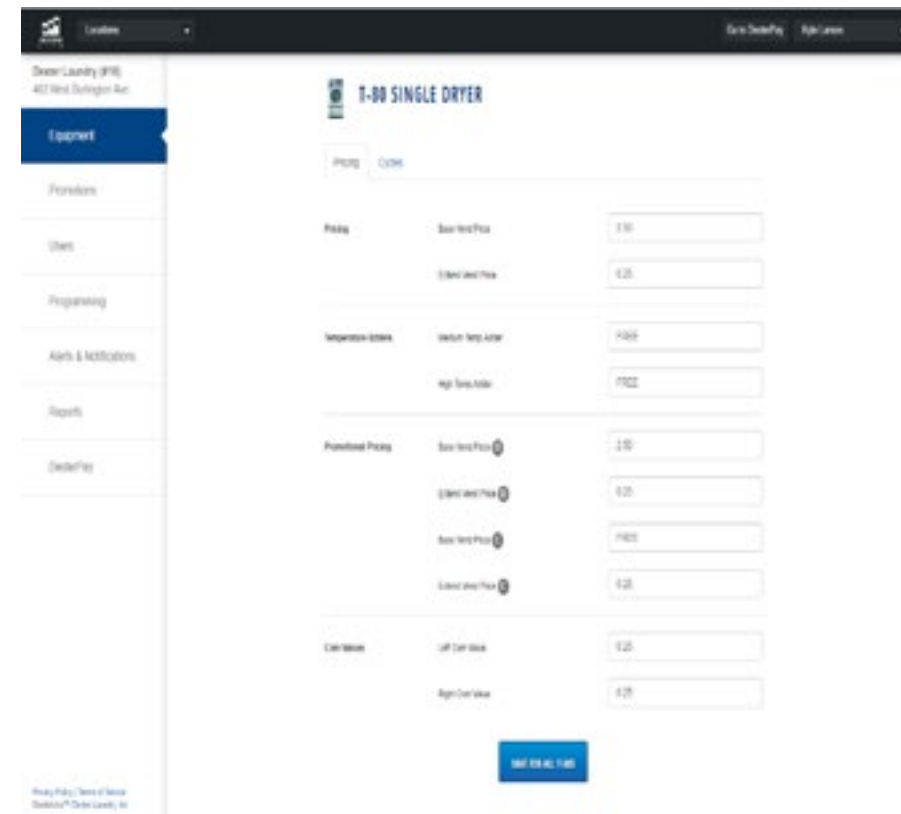

Program the price of the machine and the extra pricing adders.

F. Cycle changes can be made by selecting the "Cycles" tab.

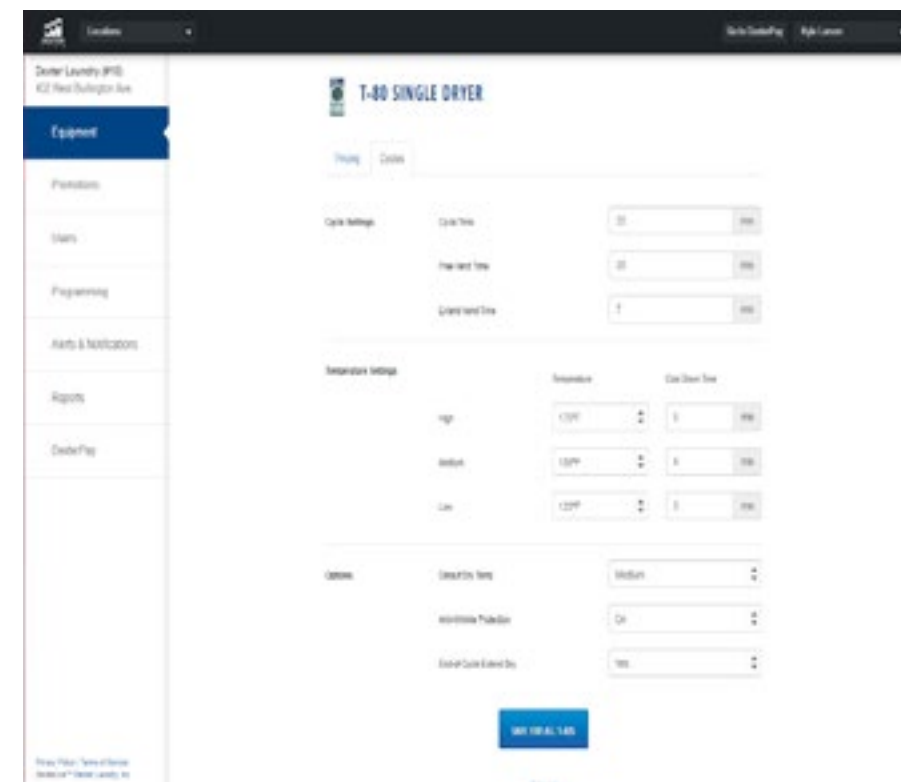

Adjust cycle programming set the length of time and extracts speed as needed.

- G. If desired, you may create and edit optional store promotions from the "Promotions" Tab.

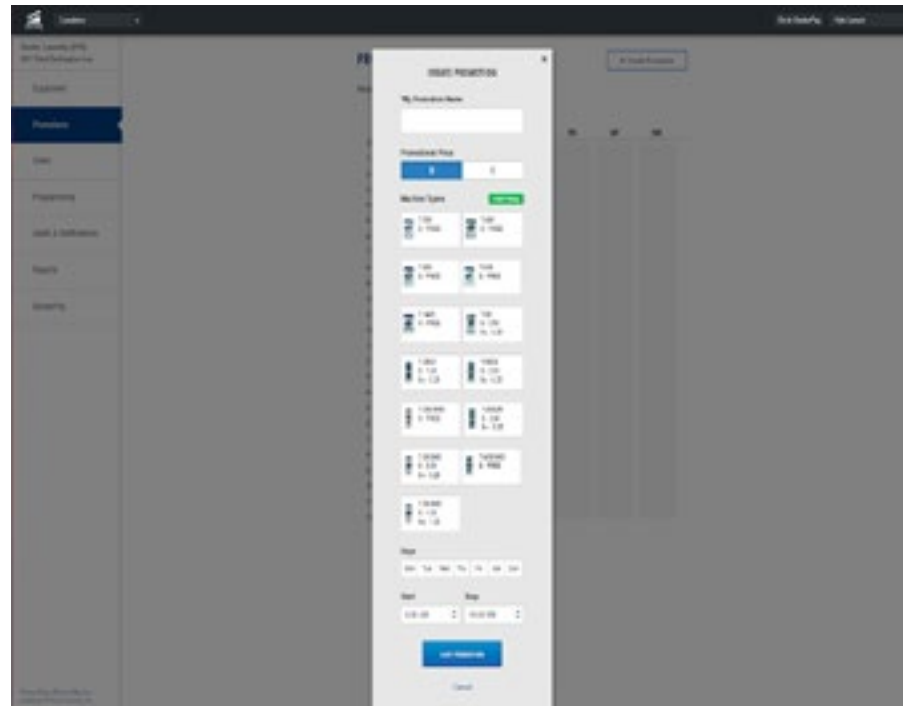

Select "Save Promotion" once your changes have been made.

- 6) Create and download the Programming File.
 A. Once all preferred prices, cycles and promotions have been modified and saved, select **"DOWNLOAD PROGRAMMING FILE"**.

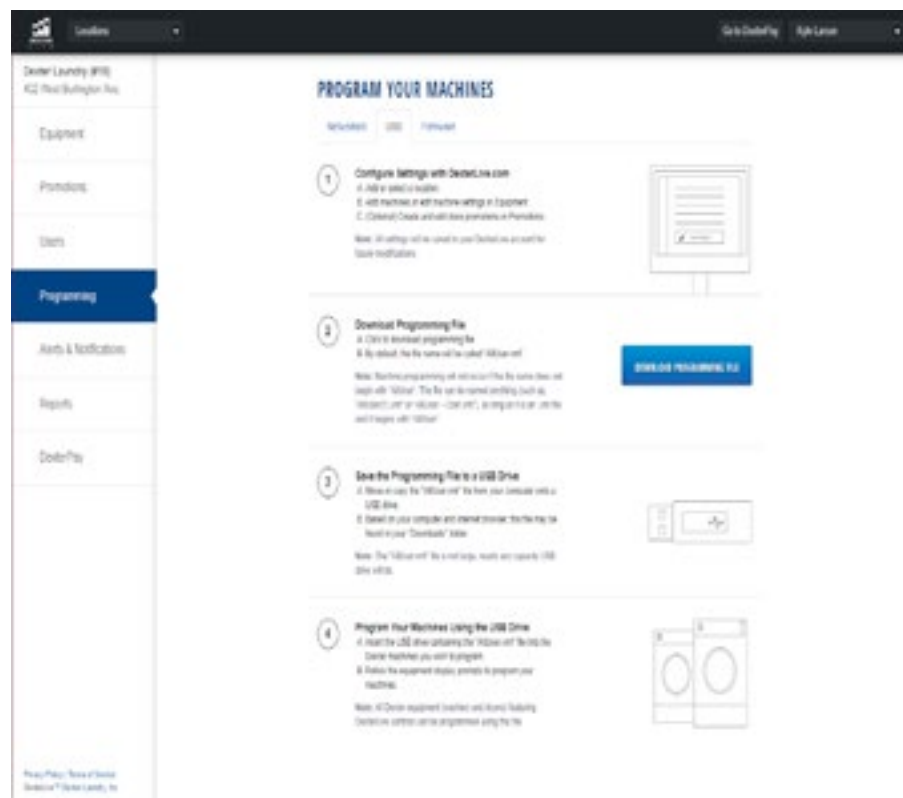

- B. Based on your internet browser the file needs to be saved as "AllUser.xml". Depending on your Internet browser you may need to retrieve the file from your "Downloads" folder, which is located under "Computer".

Note: The newly created programming file may have changed from the proper "AllUser.xml" Machine programming will not occur using a different file name than "AllUser.xml". Any extra extension names will require the file to be renamed back to "AllUser.xml" for the machine to recognize the file.

- 7) To save the Programming File to a USB Drive:
 A. Move or Copy the "AllUser.xml" file from your computer onto a USB drive.
 B. Based on your computer and internet browser, this file may be found in your "Downloads" folder, which is located under the "Computer" area.

Note: The "AllUser.xml" file size is small, nearly any capacity USB drive will do.

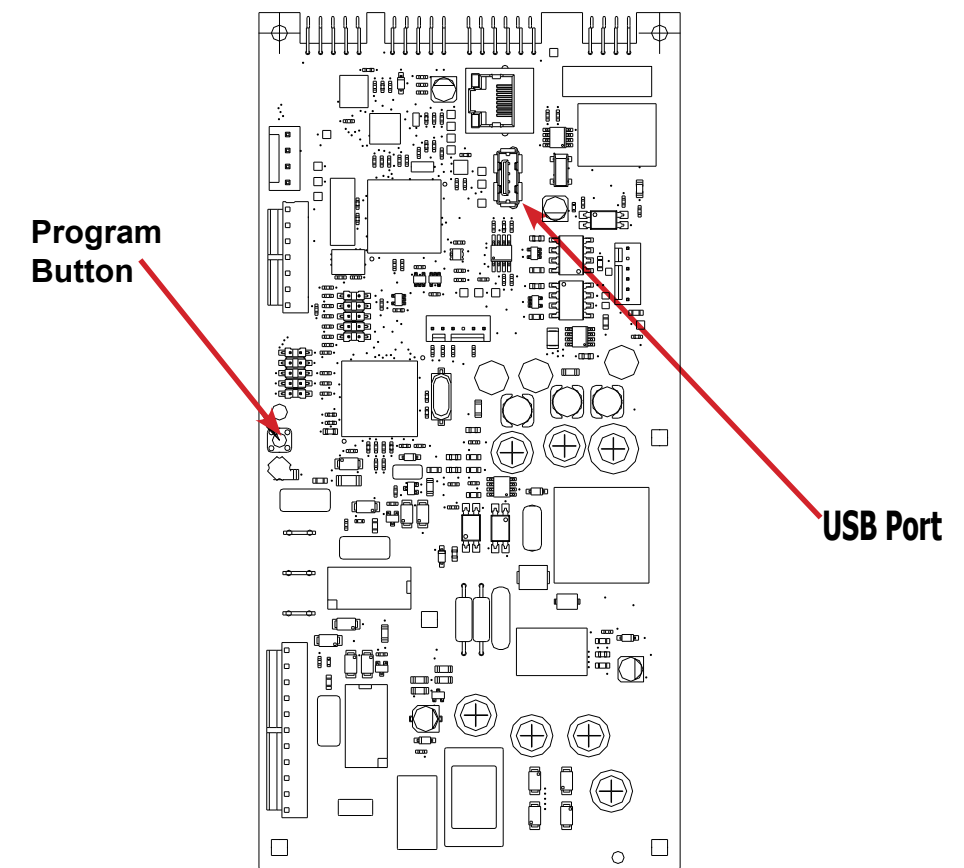

- 8) Program Your Machines Using the USB Drive

CAUTION!!! Be sure that any loose keys or other items that are connected to the USB device are removed from the USB stick to prevent any possible metal contact with the control board.

- A. Insert the USB drive containing the "AllUser.xml" file into the Dexter machines you wish to program. The control will scroll "....." while identifying the program on the USB. Once identified, the display will scroll "INSTALL USER FILE FROM USB". At this prompt press the green start button on the front panel.

- B.** The machine will scroll "TO INSTALL – PRESS START". At this prompt, press the green "Start" again.
- C.** Once the program is uploaded successfully the control will scroll "DONE REMOVE USB". The USB drive can be safely removed at this point.

Note: All Dexter equipment (washers and dryers) featuring DexterLive controls can be programmed using this file once the equipment has been configured.

PROGRAMMING THE DRYER CONTROL

The dryer control can be programmed to prompt the user for alternate vend prices, change dryer cycle times, temperatures and many other options. This can be accomplished in two ways:

1. Manual programming utilizing the "Start", "High", "Medium" and "Low" buttons for the bottom dryer.
2. USB download of a customizable User File. For instructions on using the USB download feature, please contact your local Dexter distributor or visit DexterLive.com.

MANUAL PROGRAMMING:

The dryer must be in idle mode for the manual programming menus to be accessed. Idle mode is when the dryer is not actively running a drying cycle and the vend price is displayed on the screen (for both upper and lower dryers).

To enter the manual programming mode, the control tray on the dryer must be unlocked and pulled out to reveal the programming button. The programming button is then pressed for 1 second. The control should display "DRYER PROGRAMMING".

See the figure below for the location of the programming button on the control tray.

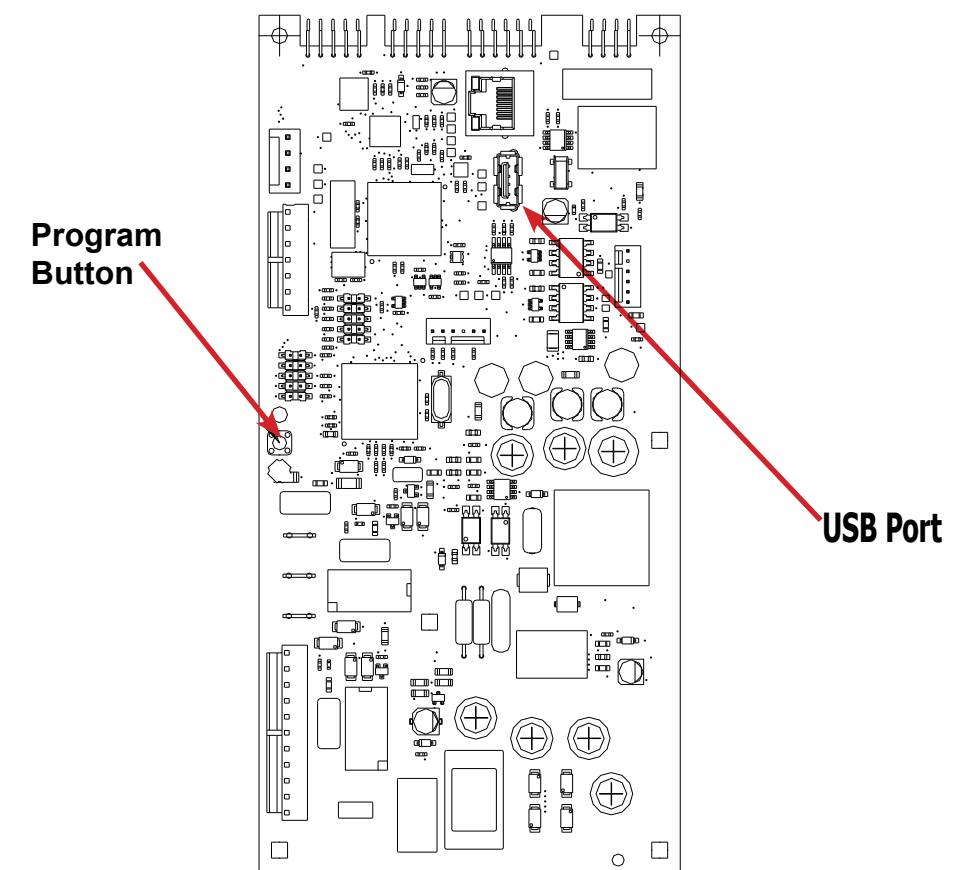

When manual programming mode is entered, the "Start", "High", "Medium" and "Low" buttons for the lower dryer perform alternate functions. Please note that the changes made using the lower dryer buttons affect both upper and lower dryers.

Button Name	Alternate Function in Programming Mode
Start	Becomes the action to accept the displayed option or the "Enter" key
High	Becomes the action to move UP through displayed options (Press & hold for accelerated scrolling)
Medium	Becomes the action to move DOWN through displayed options (Press & hold for accelerated scrolling)
Low	Becomes the action to move back a step (1 press) or EXIT from programming mode (press for 3 seconds)

These alternate functions allow the user to move through a menu of options to choose various programmable settings. The figure below shows the top level menu. Choosing an option from the top level menu will then display the next level of options (the sub menu).

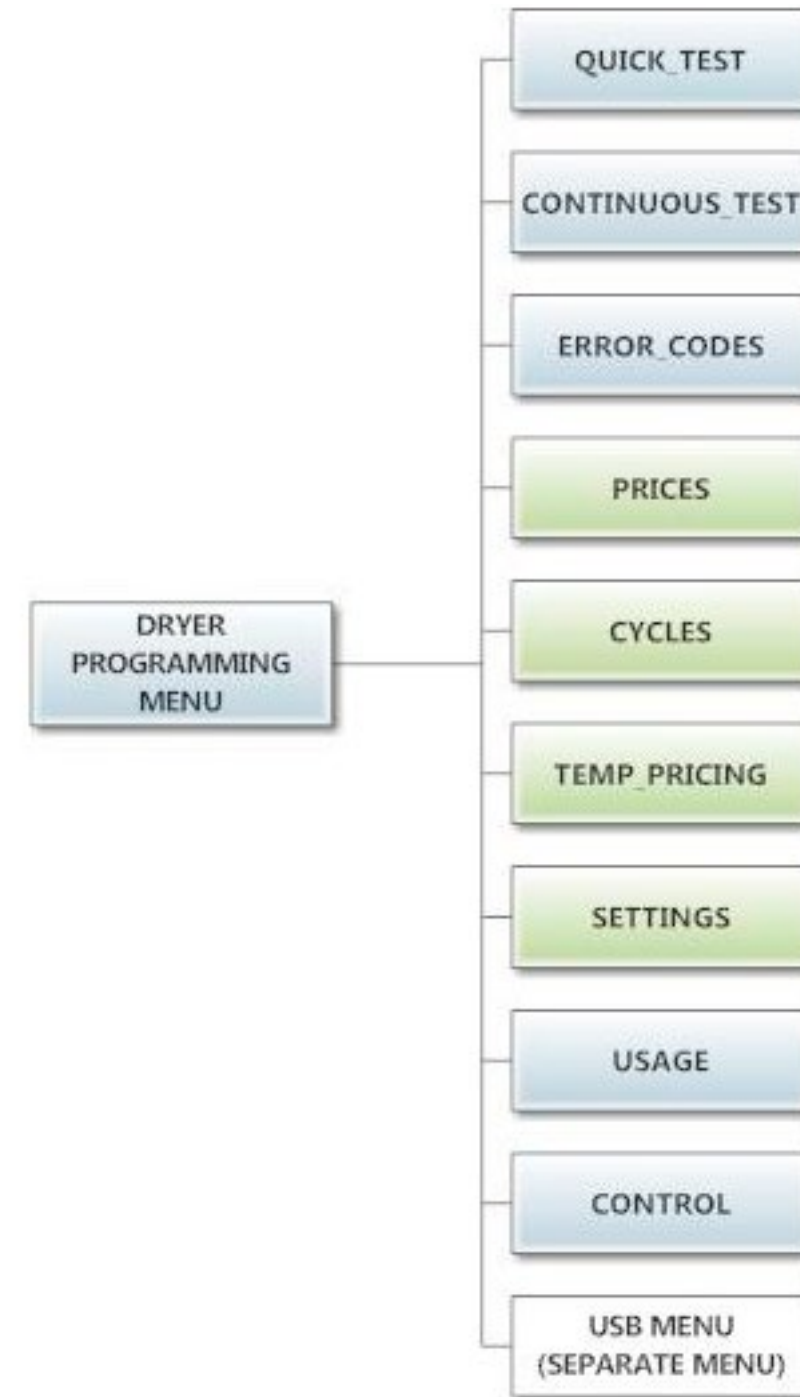

Quick Test Option:

When the Quick Test Option is chosen, the dryer will begin a shortened dry cycle without the displayed vend price being met. The purpose of this shortened cycle is to test all major components for proper operation.

Error Codes should all function normally during this test. The display will show customer prompts in a similar way to a normal dry cycle.

Continuous Test Option:

Similar to the Quick Test, when the Continuous Test Option is chosen, the dryer will begin a dry cycle without the displayed vend price being met. However, in this case, it will be a continuously-running cycle. It will not time out after any designated amount of time.

CAUTION: This option is meant for factory use only. Do not operate the dryer with this cycle active without factory authorization.

Error Code Historical Log:

The last five occurring error codes will be stored in the control with a time and date stamp. The purpose of this option is only to observe the history of these code occurrences (no changes can be made).

The time is based off the Real Time Clock, but potentially shifted by the user's manual programming changes (Shift Hours option) and/or network time override. As additional error codes occur, the oldest of the five logged codes is cleared from memory.

Prices Option:

This option allows the user to set values for coin acceptor inputs, vend price & time and extend dry price & time. It also allows the user to return the values to factory defaults. After changing prices using the "Up" or "Down" buttons, the "Enter" button must be pressed again for the control to store the changes that have been made. Note that, in general, time values are set in 1 minute increments. This can be changed to 30 second increments, by changing the "Display Time" to "MIN+SEC" (refer to the "Settings" section).

1. "RIGHT COIN" and "LEFT COIN" are the two possible inputs from coin acceptors.
2. "PRICE SET VEND" is the actual Base Vend Price (or Vend Price A) that is shown on the control display. The value can be increased or reduced even down to "0". In this case, the displays will prompt "FREE" and the cycle will start as soon as the "Start" button is pressed (without any vend price being met).
3. "TIME SET VEND" is the cycle time that the customer has available once they've met the Base Vend Price.
4. "FREE SET TIME" is the cycle time that the customer has available if the Base Vend Price is set to "FREE".
5. "EXTEND DRY" sets the price and time for additional drying time that becomes available after the customer has already met the Base Vend Price.

To reset either the coin acceptor inputs or the vend price to factory default, press "Enter" when the "DEFAULT" prompt is shown. Press "Enter" again when the "RESET" prompt is shown to confirm the action. Example- A store owner has programmed the control for the following values:

Base Vend Price	\$1.00
Base Vend Time	30 minutes
Extend Dry Price	\$.25
Extend Dry Price	8 minutes

In this case, the customer adds 4 quarters to satisfy the \$1.00 Vend Price. The display shows 30 minutes of drying time. At this point, if an additional quarter is added, the customer display shows an additional 8 minutes of drying time (38 minutes total) as per the Extend Dry Price & Time.

The customer starts the drying cycle and at 25 minutes into the cycle (13 minutes displayed), they add an additional quarter. The controller adds 8 minutes to the displayed time again (21 minutes total) as per the Extend Dry Price & Time.

"AFTER CYCLE" allows the user to choose whether a customer is allowed to add "EXTEND DRY" time for up to 30 seconds after the dryer door is opened after a completed cycle.

Prices Option:

This option allows the user to set values for coin acceptor inputs, vend price & time and extend dry price & time. It also allows the user to return the values to factory defaults. After changing prices using the "Up" or "Down" buttons, the "Enter" button must be pressed again for the control to store the changes that have been made. Note that, in general, time values are set in 1 minute increments. This can be changed to 30 second increments, by changing the "Display Time" to "MIN+SEC" (refer to the "Settings" section).

1. "RIGHT COIN" and "LEFT COIN" are the two possible inputs from coin acceptors.
2. "PRICE SET VEND" is the actual Base Vend Price (or Vend Price A) that is shown on the control display. The value can be increased or reduced even down to "0". In this case, the displays will prompt "FREE" and the cycle will start as soon as the "Start" button is pressed (without any vend price being met).
3. "TIME SET VEND" is the cycle time that the customer has available once they've met the Base Vend Price.
4. "FREE SET TIME" is the cycle time that the customer has available if the Base Vend Price is set to "FREE".
5. "EXTEND DRY" sets the price and time for additional drying time that becomes available after the customer has already met the Base Vend Price.

To reset either the coin acceptor inputs or the vend price to factory default, press "Enter" when the "DEFAULT" prompt is shown. Press "Enter" again when the "RESET" prompt is shown to confirm the action. Example- A store owner has programmed the control for the following values:

Base Vend Price	\$1.00
Base Vend Time	30 minutes
Extend Dry Price	\$.25
Extend Dry Price	8 minutes

In this case, the customer adds 4 quarters to satisfy the \$1.00 Vend Price. The display shows 30 minutes of drying time. At this point, if an additional quarter is added, the customer display shows an additional 8 minutes of drying time (38 minutes total) as per the Extend Dry Price & Time.

The customer starts the drying cycle and at 25 minutes into the cycle (13 minutes displayed), they add an additional quarter. The controller adds 8 minutes to the displayed time again (21 minutes total) as per the Extend Dry Price & Time.

"AFTER CYCLE" allows the user to choose whether a customer is allowed to add "EXTEND DRY" time for up to 30 seconds after the dryer door is opened after a completed cycle.

The figure below shows the sub menu options for Prices:

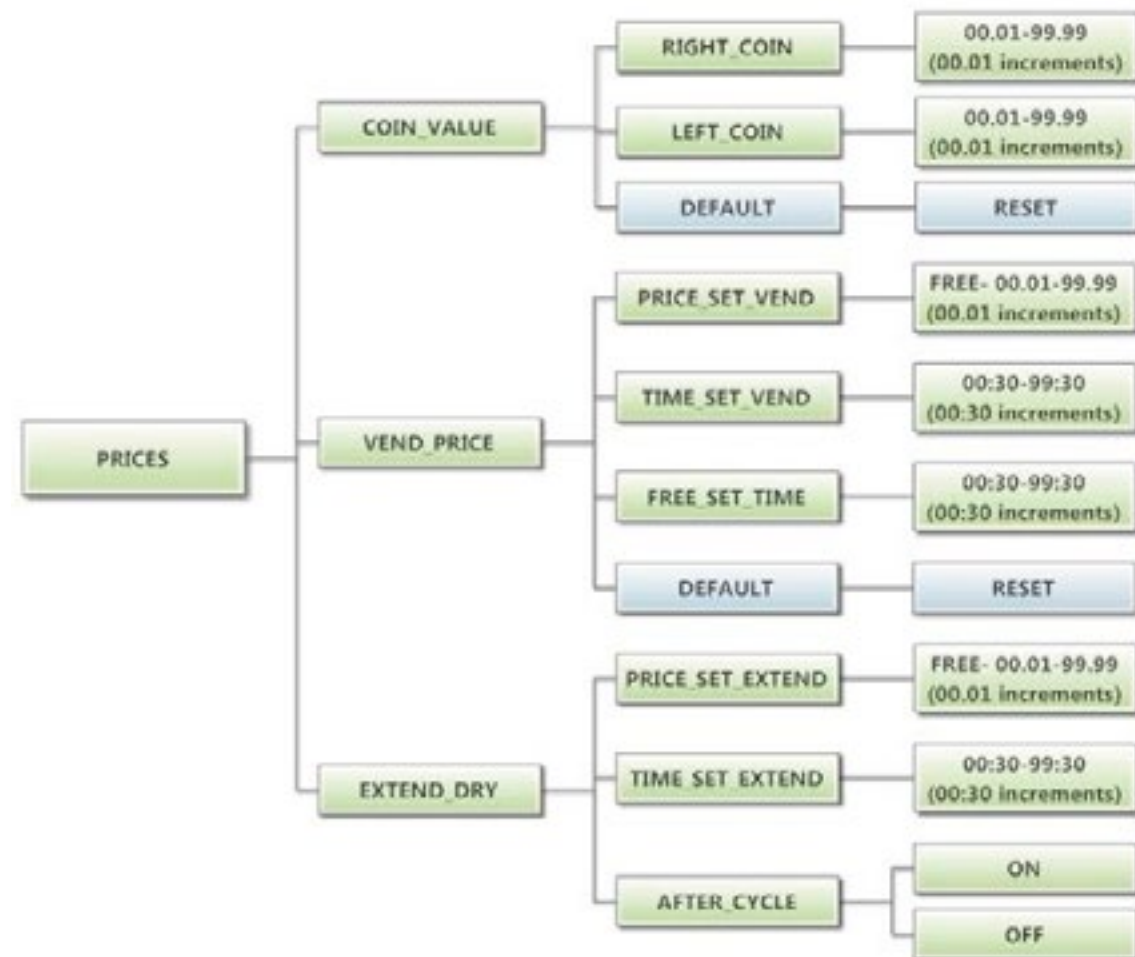

Cycles Option:

This option allows the user to set temperature and cooldown information for the drying cycle. It also allows the user to return the values to factory defaults.

1. "TEMP SETTINGS" allows the user to make adjustments, within a designated range, to the cycling temperature for each of the "Low", "Medium" and "High" customer choices.
2. In addition, on the "Low" setting, the user can reduce the cycling temperature below 110 degrees F. In this case, when the customer chooses the "Low" setting, the dryer will not turn on the gas valve. When checked, the displayed temperature will read "NO HEAT".
3. "COOLDOWN" allows the user to change the designated time at the end of a cycle where the gas valve relay is turned off. On "High" and "Medium" temperature settings, the designated time cannot be reduced to less than 2 minutes.
4. "DEFAULT TEMP" allows the user to choose which general temperature setting, "High", "Medium" or "Low", the control will default to at the beginning of each cycle if the customer does not make a choice.
5. "ANTI WRINKLE" is a feature that periodically rotates the dryers after a cycle is complete. If the door was closed at the end of the cycle, and is left closed for 5 minutes, the enunciator will sound and the display begins scrolling "ANTI WRINKLE". 5 seconds later, the dryer motor will turn on for 60 seconds and then turn off. The gas valves will not be turned on. The "ANTI WRINKLE" message will continue throughout the time that the motor is turned on. The user can choose to enable or disable this feature.
6. "MAX CYCLE TIME" allows the user to set the maximum time that can be purchased for a cycle. This includes the total time purchased before the cycle is started, while the cycle is running, and after the cycle ends.

To reset all values in the Cycles option to factory default, press "Enter" when the "DEFAULT" prompt is shown. Press "Enter" again when the "RESET" prompt is shown to confirm the action.

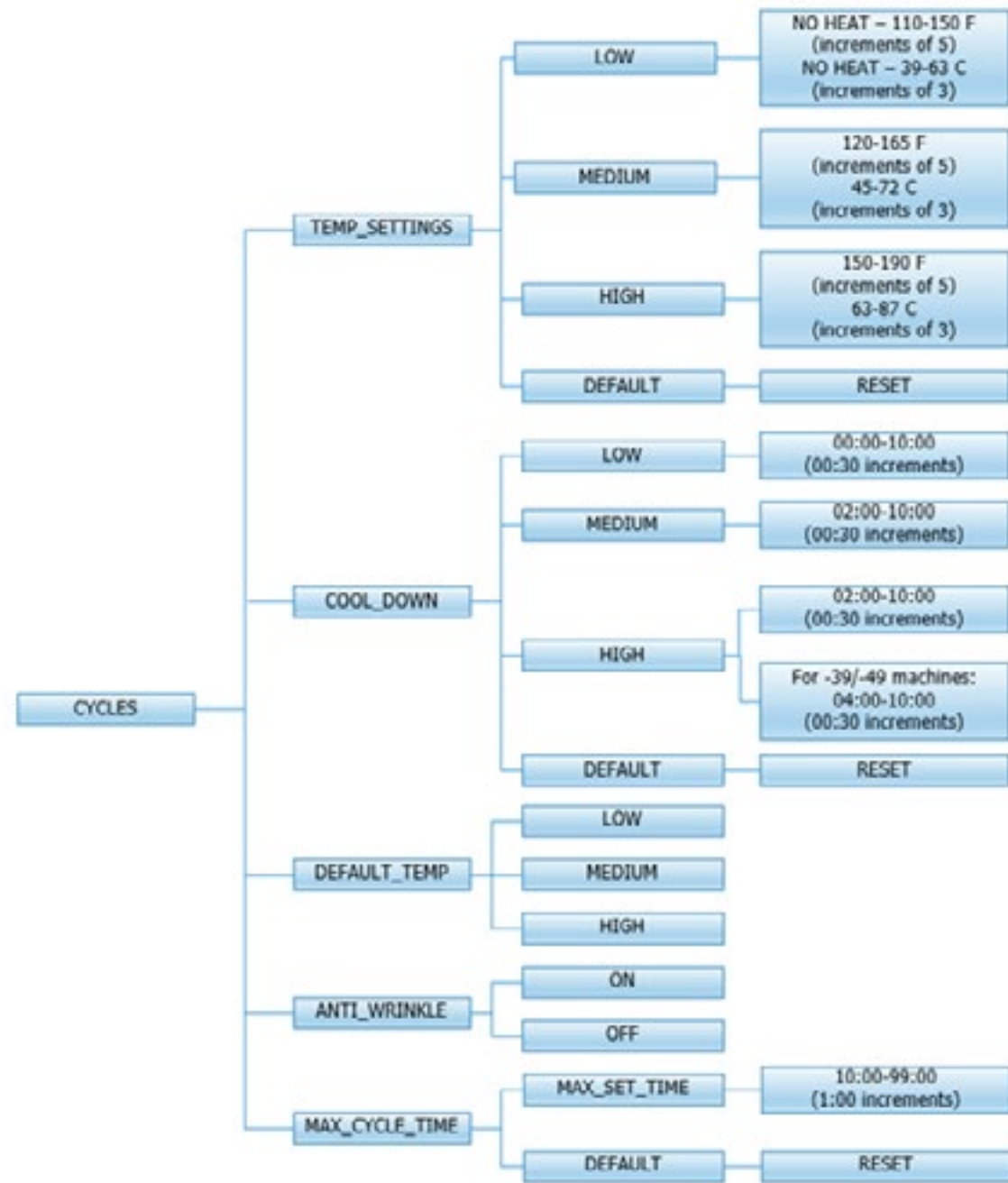

Temperature Pricing Option:

This option allows the user to require additional vend amounts be added based on the drying temperature chosen by the customer. This pricing adder is effective only for the Base Vend Price (it does not affect the Extend Dry Price). It allows a pricing adder separate for "Medium" and "Hot" temperature settings. Example- A store owner has programmed the control for the following:

Vend Price	\$1.00
Vend Time	30 minutes
Extend Dry Price	8 minutes
Medium Adder	\$.25
Hot Adder	\$.50

In this case, the Vend Price is displayed as:
 \$1.00 if Low Temperature is chosen
 \$1.25 if Medium Temperature is chosen
 \$1.50 if Hot Temperature is chosen

When Temperature Pricing Adders are in place (user has chosen a higher value than \$0.00), if the customer attempts to change their temperature selection from a lower temperature to a higher one during a drying cycle, there will be no change in the temperature selection. The higher temperature buttons are disabled until the drying cycle is complete and a new Vend Price is required. The figure below shows the sub menu options for Temperature Pricing:

The figure below shows the sub menu options for Temperature Pricing:



Settings Options:

The Settings options allow for the user to make various programming changes to change how the control operation affects the customer. See below for detailed information on each next level option.

1. "Decimal Point": If the user programs the Decimal Point to "OFF", control display will not show a decimal point on any vend price values. The factory default is "ON".
2. "Display Time": If the user programs this value to "MIN", then minutes only will be shown for the cycle time. If it is programmed to "MIN+SEC", then minutes and seconds will be shown. This also allows other programming changes, involving time, to be made in either minute increments or minutes & seconds increments, as desired.
3. "Temp Scale": If the user programs this value to "F", then the temperatures will be displayed in Fahrenheit units. If it is programmed to "C", then the temperature will be in Celsius units.
4. "Sounds": If the user programs the Sounds to "OFF", the control will not sound the enunciator at the end of a dry cycle. The factory default is "ON".
5. "Password": If the user programs the password to any value other than 0000, the control will prompt the user to enter a password (the programmed value) before manual programming can be accessed. The factory default is "0000" (no password).
 - a. Note that if the user forgets the Password, it can be reset to factory default (no password), by performing a hard reset on the control. Please refer to the appropriate section of this manual to understand how to perform a hard reset.
 - b. The individual digits of the Password can be set by using the "Up" or "Down" buttons to change the number that is flashing. Once the desired number is chosen for a single digit, press the "Enter" button to move to the next one. Once all four desired digits are chosen, the "Enter" button must be held down for 3 seconds to confirm that the complete password should be set.
6. "Central Pay": If the user programs this value to "ON", the left and right coin inputs become upper and lower dryer coin inputs.

Central Pay "OFF"	Central Pay "ON"
Left Coin Input	Upper Dryer Input
Right Coin Input	Lower Dryer Input

A system can then be installed that will register coin inputs per individual dryer remotely from a Central Pay kiosk. The left and right coin prices must be appropriately programmed. When this option is enabled, the controller will only display customer prompts for a designated dryer. This designated dryer is determined when coins are inserted at the Central Pay kiosk.

7. "Language": The control uses English for the default language of the customer prompts. Alternatively, the user can choose Spanish or French for the customer display prompts. However, all other prompts, such as Manual Programming, USB Programming and any Error Codes will still display in English.

8. "Shift Hours": This feature allows the user to shift the time used by the control from the time kept internally by the control. The control uses a Real Time Clock (RTC) to internally track the time and date. The RTC continues operation even if the control loses external power. The RTC is set for Central Standard Time and no daylight savings. Because the machine may be located in another time zone, the user can choose to create an alternate time & date that tracks in parallel to the RTC. When this alternate time is chosen, or shifted from the RTC, the alternate time will be used to, for example, track error code occurrences and set time-of-day pricing changes.
 - a. The hours in "SHIFT HOURS" can be set by using the "Up" or "Down" buttons to change the number that is flashing. Once the desired hour shift is chosen, press the "Enter" button to move to the minutes. Once the hours and minute shift are both chosen, the "Enter" button must be held down for 3 seconds to confirm that the complete shifted time is set.
9. "Time": The control uses a Real Time Clock (RTC) to internally track the time and date. The RTC continues operation even if the control loses external power. The RTC is set for Central Standard Time and no daylight savings. However, if a problem occurs and the RTC time is not accurate, it can be reset to the current time using this option.
 - a. The hours in "TIME" can be set by using the "Up" or "Down" buttons to change the number that is flashing. Once the desired hour is chosen, press the "Enter" button to move to the minutes. Once the hours and minute are both chosen, the "Enter" button must be held down for 3 seconds to confirm that RTC is meant to be reset to the complete entry.
10. "Date": Similar to "Time", if a problem occurs and the RTC date is not accurate, it can be reset to the current date using this option.
 - a. The day of the month in "DATE" can be set by using the "Up" or "Down" buttons to change the number that is flashing. Once the desired day of the month is chosen, press the "Enter" button to move to the month of the year. Once the desired month of the year is chosen, press the "Enter" button to move to the year. Once the day, month and year are all chosen, the "Enter" button must be held down for 3 seconds to confirm that RTC is meant to be reset to the complete entry. To reset all values in the Settings options to factory default, press "Enter" when the "DEFAULT" prompt is shown. Press "Enter" again when the "RESET" prompt is shown to confirm the action.
11. "Out of Service" – The control can be put into an Out-of-Service mode via manual programming. When the mode is "ON", the control will scroll "OUT OF SERVICE" on the display. The machine will not react to any vend input and will not operate when in this mode. The factory default is "OFF".
12. "Alt Cool Down": This setting is for factory use only.

To reset all values in the Settings options to factory default, press "Enter" when the "DEFAULT" prompt is shown. Press "Enter" again when the "RESET" prompt is shown to confirm the action.

The figure below shows the sub menu options for Settings:

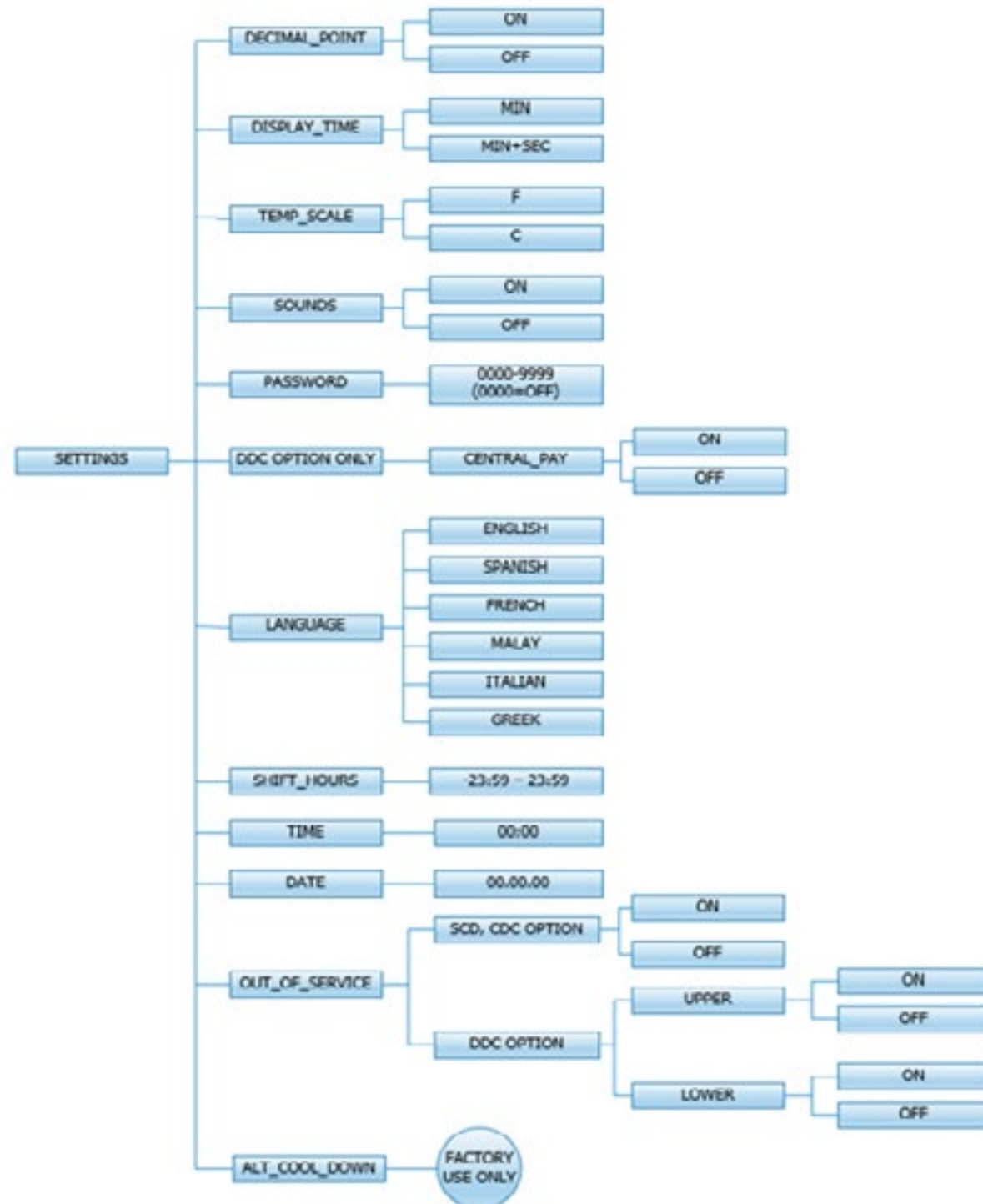

Usage Menu:

The Usage menu allows for the user to track data about machine usage. See below for detailed information on each sub menu option.

1. "Coin Audit": The coin audit field shows the accumulation of coin pulses that were sent to the control over each of the left and right coin inputs. Note that this is a count of coin pulses, not an accumulated report of vend value.
 - a. The user can also return the coin audit amounts to the factory default setting (zero). To reset all coin audit values, press "Enter" when the "DEFAULT" prompt is shown. Press "Enter" again when the "RESET" prompt is shown to confirm the action.
2. "Motor Hours": The motor hours field shows the accumulated hours of operation for both the upper and lower motors independently. In many cases, it will match the cycle hours of the machine. However, separate fields are provided in the event that a motor is replaced on a machine. The user can set the motor hours to a designated number. For example, if it is necessary to replace the control on a machine, the new control could be programmed to show the motor hours that were recorded by the previously installed control. The individual digits of the hours count can be set by using the "Up" or "Down" buttons to change the number that is flashing. Once the desired digit of the hours is chosen, press the "Enter" button to move to the next digit. Once the complete hours are chosen, the "Enter" button must be held down for 3 seconds to confirm the action.
 - a. The user can also return the motor hours to the factory default setting (zero). To reset the motor hours, press "Enter" when the "DEFAULT" prompt is shown. Press "Enter" again when the "RESET" prompt is shown to confirm the action.
3. "Cycle Hours": The cycle hours field shows the accumulated hours of operation for both the upper and lower dryer dryers independently. In many cases, it will match the motor hours of the machine. However, separate fields are provided in the event that a motor is replaced on a machine. See the Motor Hours description for more information.

The figure below shows the sub menu options for Usage:



Section 4:

Dryer Service Procedures

Trouble Shooting and Schematics

Service Procedures

Pressure Testing

The dryer and its individual shutoff valve must be disconnected from the gas supply piping system during any pressure testing of that system at test pressures in excess of 1/2 psig (14" water column). The dryer must be isolated from the gas supply piping system by closing its individual manual shutoff valve during any pressure testing of the gas supply piping system at test pressures equal to or less than 1/2 psig.

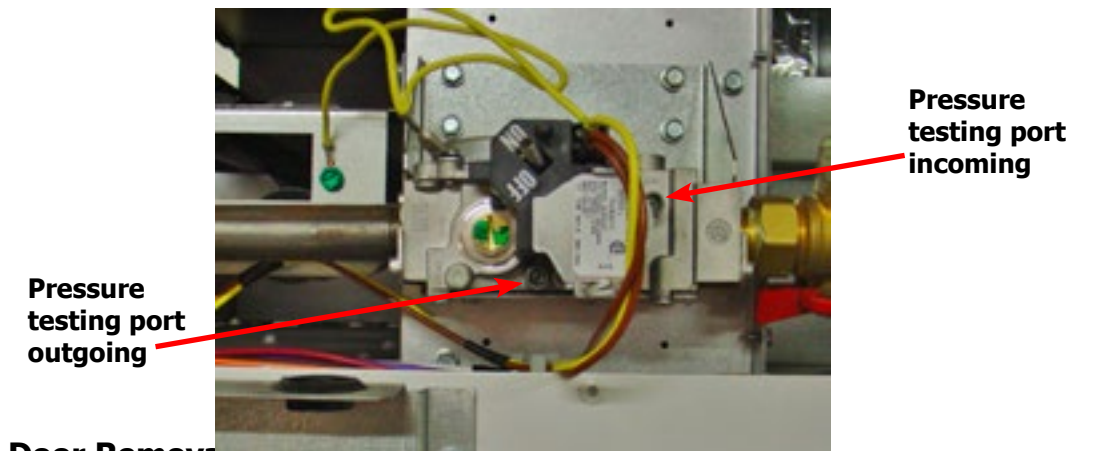

Clothes Door Removal

- Step 1: Open door and remove inner hinge plate cover by removing the two Phillips screws.
- Step 2: The clothes door may be removed from the hinge bracket by unscrewing and removing the top 3/16 allen head pivot screw located at the door upper hinge point, you will also need to use a 1/4 allen wrench in the lower fastener.
- Step 3: Next lean the door out of the top of the hinge bracket and lift the door from the bottom hinge pin.

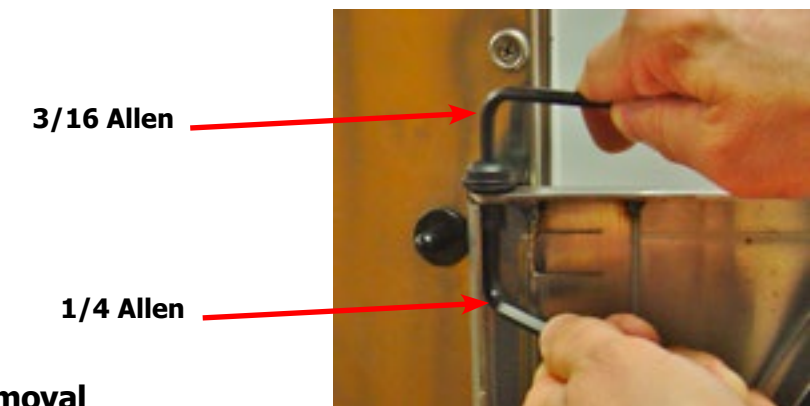

Front Panel Removal

- Step 1:** Remove the loading door from the panel (optional, the front panel may be removed without taking off the door).
- Step 2:** Open upper service door, and remove lint door.
- Step 3:** Then remove the two left side phillips screws w/ beveled washers and the two right side phillips w/ beveled washers screws. Next disconnect door switch wires from back of loading door switch.

Door Switch Removal & Installation

Step 1: Remove front panel (see front panel removal).

Step 2: Next disconnect door switch wires from back of loading door switch. Remove door switch by depressing the bottom tab on the switch with a flat head screw driver. Then slide the bottom of the switch toward the front panel. Pull the switch out at a 45° angle.

Note: For the 80Lb., you will have to remove the door switch cover first by removing the two 3/8" nuts.

Step 3: reassemble in reverse order.

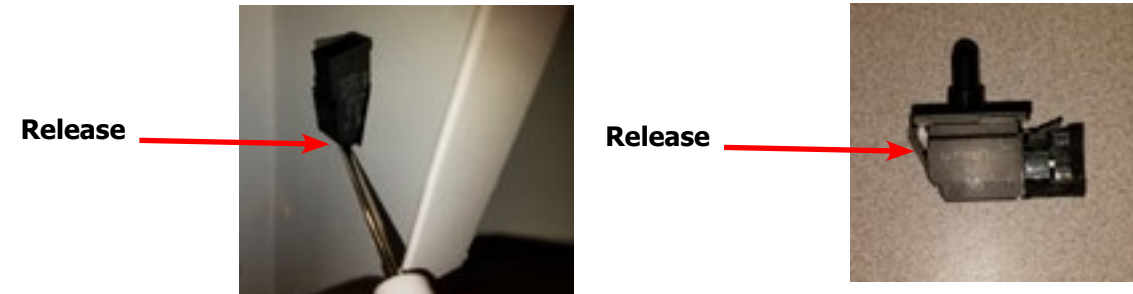

Door Switch Operation & Testing

The normally open door switch must be closed (0 ohms resistance) for the motor and heat circuits to operate. When the door is opened, the door switch opens the 24 volt control circuit.

Clothes Door Latch Adjustment

Step 1: Loosen the lock nut on the latching stud. It is located directly behind the door handle.

Step 2: Open the loading door.

Step 3: Screw the door catch stud in or out as necessary and then retighten the lock nut.



Installation of Clothes Door Window & Gasket

Step 1: Remove the loading door.

Step 2: Place the clothes door, with its face down, on a solid surface.

Note: Pre-warming the gasket under a heat lamp makes the installation much easier.

Step 3: Put the door glass gasket on the loading door with the ridges in the wide side up. Locate the seam at the door latching stud.

Note: The gasket has one narrow opening on one side and a wide opening on the other. The narrow side mounts to the door. The wide side holds the glass. The wide side has ridges on one interior lip. This ridged side should go up with the door lying face down.

Step 4: Coat the inside and outside of the gasket with rubber lubricant or liquid soap.

Step 5: Slide the glass into the middle of the gasket with half of the glass above the door and half below the door.

Step 6: While pressing on the glass, use a modified screwdriver (grind the end off so that it is round and put a slight bend in it) and run it around half of the glass.

Step 7: With half of the glass installed, turn the door over and repeat step 6.

Step 8: Insert the modified screwdriver at the 6 o'clock position and pry the glass up enough to install the door glass support spacer (small diameter rubber tube).



Glass inserted half way

High Limit Thermostat Locations & Functions Burner Housing

This hi-limit is located on the rear of the burner housing.

STEP 1: The thermostat opens the circuit to the main burners in the event of malfunction in the gas control area or temperature control. This thermostat will open quickly if there is a significant loss of air flow over the burner area.

STEP 2: It is held in place by two screws. There are spacers between the thermostat and bracket which must be used to give proper operation.

Removal : To remove the hi-limit thermostat on the side of the burner housing, remove the terminal of each wires attached to the thermostat. Lastly, remove the mounting screws holding the thermostat to the burner housing.

High Limit Thermostat



Manual Resettable Over Temperature Safety Thermostat

The second hi-limit thermostat is located outside the rear exhaust opening mounted on the left side of the exhaust duct at the rear outlet height.

Step 1: The manually resettable thermostat limits the operating temperature a dryer can reach should some abnormal situation occur.

Step 2: Should the thermostat be tripped, the dryer will cease to heat until the thermostat is reset. Once the dryer cools, the thermostat may be reset by pushing the button in.

REMOVAL: To remove the manual resettable over temperature safety thermostat next to the exhaust duct. First, remove the terminals of each wire attached to the thermostat. Next, remove mounting screws holding the thermostat to the dryer cabinet.

Overtemp Thermostat

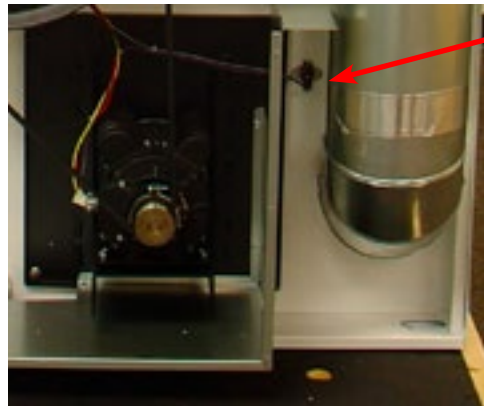

Pressure Regulator Adjustment

Use the following procedure whenever it is necessary to check the pressure regulator setting. NOTE: Any adjustment of the pressure regulator must be made with a manometer attached at the plug in the main burner manifold.

Step 1: Shut off the gas supply to the dryer.

Step 2: Remove the 1/8" pipe plug from the end of the main burner manifold.

Step 3: Attach a manometer to the manifold end.

Step 4: Remove the pressure regulator cover screw on the gas valve.

Step 5: Open the shut-off valve, and operate the dryer.

Step 6: Adjust the pressure for a manometer reading of 3.5" water column gas pressure. (11.0" for L.P.)

NOTE: The main burners must be operating when adjusting the pressure regulator.

Step 7: Shut off the gas supply to the dryer. Remove the manometer and install the 1/8" pipe plug in the manifold.

Step 8: Open the shut off valve, start the dryer and check for gas leaks while the burners are ignited.

NOTE: Always remove power from the machine before changing drive belts or working with the drive and fan system.

1/8" pipe plug

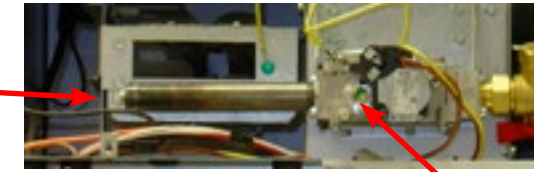

Adjustment Screw Under Plug

Final Drive Belt Replacement

To replace the final drive belt turn the cylinder slowly by hand and work the belt off of the large pulley.

Motor Drive Belt Replacement

To replace the motor drive belt the final drive belt should be removed as above. Next turn the intermediate drive pulley and work the belt off of it similarly to the above belt.

Blower Motor Removal

Step 1: Remove Rear upper and lower Belt pulley guards.

Step 2: Remove rear electrical box cover.

Step 3: Remove left and bottom side guard.

Step 4: Remove belts.

Step 5: Disconnect wires from the over temperature switch and cut the two wire ties securing gray wire to motor harness.

Step 6: Remove the wire clamp holding motor wire loom to cross member by removing the 5/16 screw.

Step 7: Remove the two beaded ties securing harness behind pulleys.

Step 8: Remove last wire tie connecting gray wire to motor harness.

Step 9: Next, inside the rear control box disconnect red wire, 1/4 inch quick connect inside splice connector.

Step 10: Remove black and yellow wires from R1 relay.

Step 11: Remove motor harness from control box.

Step 12: Next remove blower motor, back plate, and impeller from machine by removing the four 9/16 nuts.

Reassemble in reverse order.

Blower Impeller Removal

Remove Blower motor assembly. Take notice of the location of the impeller location on the shaft. Remove the two set screws that hold the motor to the shaft.

Airflow switch removal and adjustment

The air switch assembly is part of the ignition safety circuit and insures that the burner doesn't operate unless there is airflow. If this doesn't happen, ignition will not occur. The air switch assembly is located on the back of the Dryer.

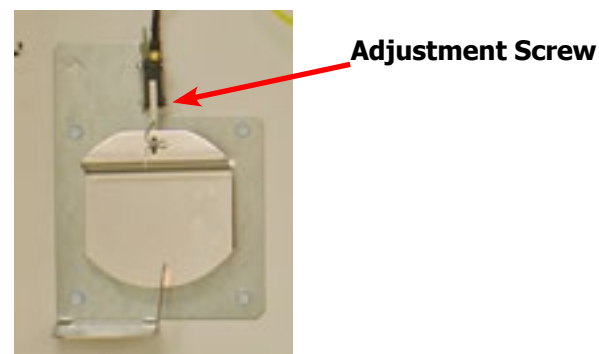

Electronic Ignition Module

This machine uses an electronic spark ignition system to directly light the burners.

- Step 1:** The electronic ignition module (gray box) is located inside the rear control box.
- Step 2:** The red wire from the transformer provides 24 VAC through the 1.5 amp fuse and into the module to operate the entire direct ignition system.
- Step 3:** The black colored hi-voltage wire (spark plug type) plugs onto the post connector on the module, and the multi-wire plug fits into the side of the module.

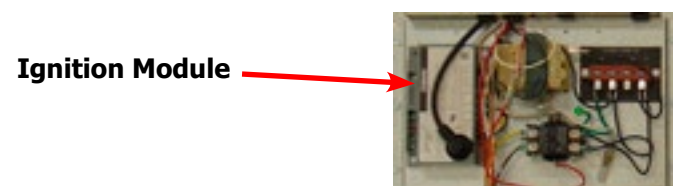

Spark Electrode Assembly-Removal

- Step 1:** Disconnect wires to electrodes.
- Step 2:** Remove two screws to detach electrode assembly.

NOTE: Proper grounding of the ignition system (yellow wires) is very critical for proper ignition sequence

If there is no spark or intermittent spark, check black hi-voltage lead wire for damage or cracks in insulation. This lead wire must not be taped or connected to any metal edges along its length to prevent pinching and arcing. Also, do not bundle this wire with other wires.

Note : Spark gap and electrode location are important. If the electrode is damaged or mounting is changed the spark gap may not be correct for ignition to occur. Check for cracks in the ceramic insulator. Replace electrode assembly if necessary. Also check for carbon or foreign material on the electrodes and clean if necessary.

Gas Valve & Manifold Removal

- Step 1:** Disconnect union at gas valve and disconnect wires from gas valve operator coils.
- Step 2:** Remove Gas Valve mounting bracket by removing the 4 5/16 screws.

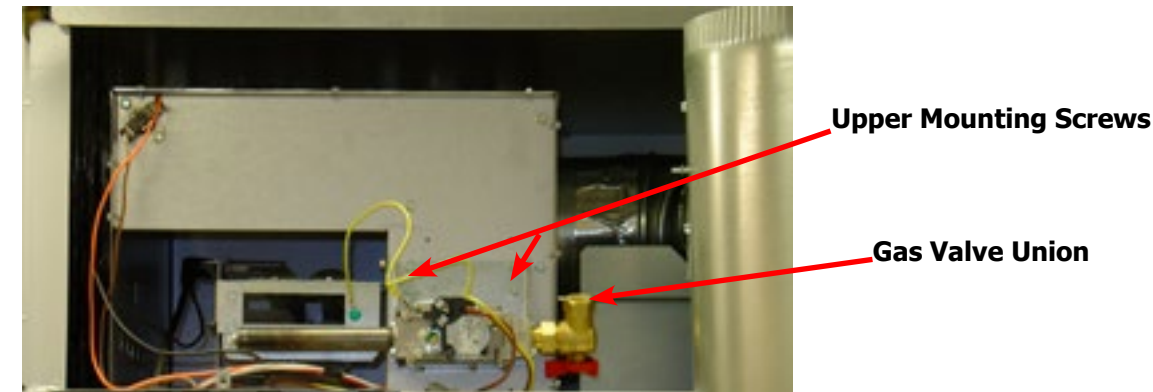

Main Burner Orifice Removal

- Step 1:** Remove manifold and gas valve assembly as above.
- Step 2:** Using an open end wrench, remove orifices from manifold.

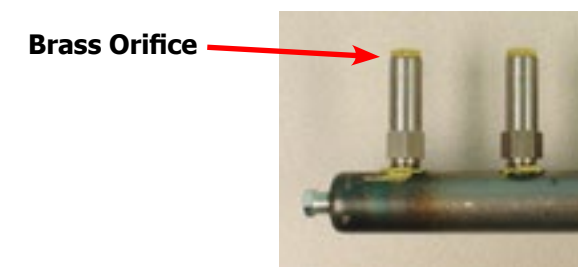

Main Burner Removal

Remove manifold & gas valve assembly as previously discussed. Remove the four 9/16 screws securing the front of the burner to the support bracket. The burners may now be removed.

Cylinder Pulley Removal

30Lb
Remove bolt and washers holding pulley to cylinder shaft. Reinsert bolt then using two or three jaw puller Pull pulley straight off of shaft.
50Lb & 80Lb
Remove bolt and washers holding pulley to cylinder shaft. Reinsert bolt then using "T" puller w/ 3/8-16UNC bolts, Pull pulley straight off of shaft.

Intermediate Pulley Removal

30Lb & 50Lb

The intermediate pulley can be removed by removing the snap ring holding the pulley to the tension arm.

Note: Cylinder pulley must be removed first.

80Lb

The intermediate pulley can be removed by removing the nut holding the pulley to the tension arm.

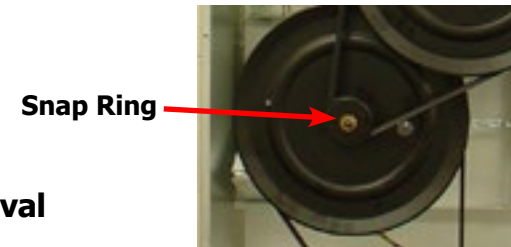

Tension Arm Assembly Removal

The tension arm assembly may be removed by removing the snap ring that holds it to the tension arm support assembly pin. If it is necessary the arm assembly is replaced as a complete unit.

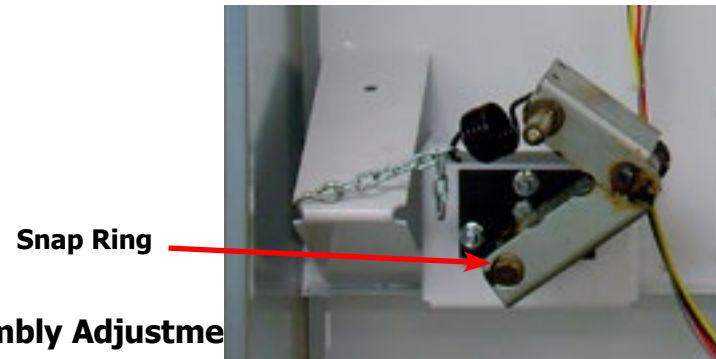

Tension Arm Support Assembly Adjustme

The tension arm support assembly may be adjusted for alignment of the intermediate pulley and also to align the belts. The three outer nuts allow the alignment of the pin to be adjusted by pivoting the assembly on the center bolt. The center bolt can be screwed in to allow bringing the complete assembly farther back if necessary for belt alignment.

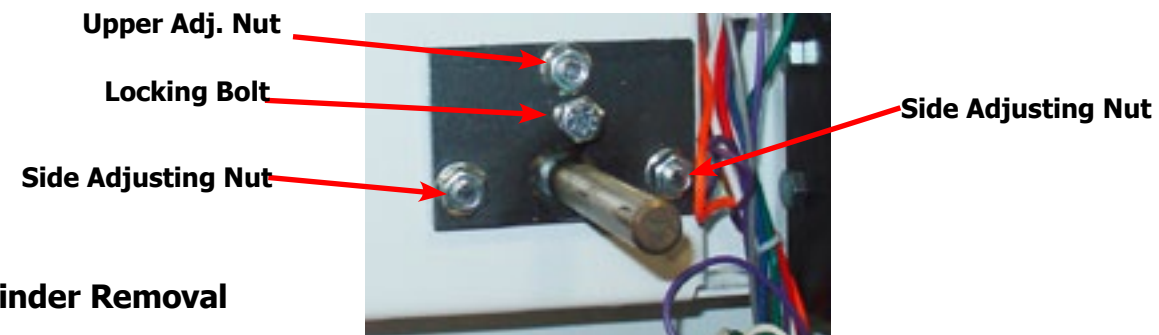

Cylinder Removal

Step 1: Remove the front panel in front of the cylinder.

Step 2: Remove drive belt, bolt, washers, and pulley.

Step 3: Pull the cylinder from the front of the machine.

Adjustment of Cylinder Assembly

Step 1: Loosen the two top adjusting bolts and two bottom adjusting nuts and lock nuts holding the bearing housing to the drive plate.

Step 2: Loosen the four mounting bolts on the side channels.

Step 3: Open the clothes door and insert a 1/2" thick shim at the 3 and 9 o'clock positions and a 1/4" thick shim at the 6 o'clock position.

Step 4: Tighten the two bottom adjusting nuts and tighten locking nuts.

Step 5: Tighten the bottom right mounting bolt, then the top left mounting bolt. Tighten the remaining two bolts. (Shim where and if necessary.)

Step 6: Tighten the two top adjusting bolts.

Step 7: Remove all the shims from between the front panel flange and cylinder. (3,6,9 and 12 o'clock).

Step 8: Spin the cylinder to check for rubbing baffles, pressing down hard while rotating. If rubbing is detected, repeat procedure paying particular attention to placement of shims between bearing housing and side channels.

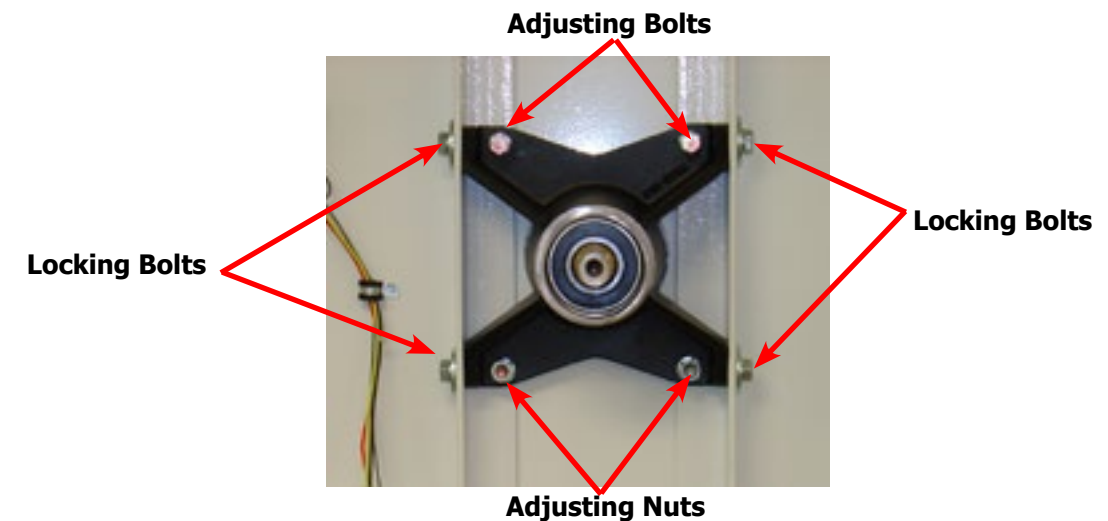

Bearing Housing Removal

After removing cylinder as previously outlined, simply unbolt the four outside bolts and the two lower nuts and remove the bearing housing.

Spark Electrode Assembly-Function

Step 1: The spark electrode and sensing electrodes are located directly at the side of the burner housing.

Step 2: The electrode with the black hi-voltage wire conducts the spark to the center grounding probe, directly over the burner.

Step 3: The electrode with the black sensing wire detects ignition and monitors flame by signaling the module.

NOTE: Proper grounding of the ignition system (yellow wires) is very critical for proper ignition sequence.

Ignition System-Function & Sequence

During normal dryer operation, the following occurs:

1. The dryer electronic control calls for heat.

2. From the 24VAC control transformer, voltage for the heat circuit is applied to the control through the door switch. If the control detects that the heat should be on, a circuit is closed providing power through the over-temp thermostat, the air damper switch, the high limit switch and the motor centrifugal switch to the Ignition Module. Once the 24VAC reaches the ignition module on the red wire, sparking occurs at the ignition electrode and 24VAC is applied to open the Gas Valve.

3. Once the flame is established, the sensing electrode detects the presence of flame and the sparking stops.

4. If for any reason the flame is not established in a period of 10 seconds, the electronic control will try this sequence for 3 tries. Normally the 10 seconds "Trial For Ignition" period is ample to establish and prove flame.

5. If the flame is shutdown or blown out during operation, the ignitor will immediately go into "Trial. For Ignition" again for 10 seconds.

6. However, at the end of 3 separate retries of 10 seconds "Trial for Ignition", the flame is not established, the ignition system goes into "Safety Lock-Out" and will not reactivate the "Trial for Ignition" until there is a current interruption for a period of 15 seconds. This interruption can be provided by opening the dryer loading door and allowing the machine to come to a complete stop for 15 seconds.

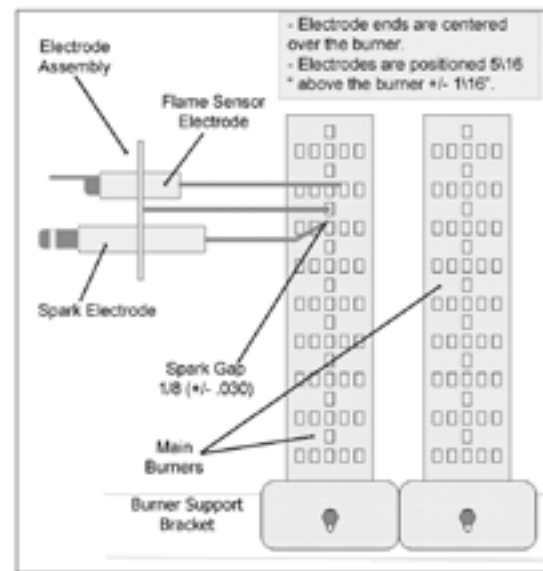

Dryer Trouble Shooting

Symptom	Probable Cause	Suggested Remedy
Tumbler does not turn	Drive belts	Check both drive belts. Replace if failed.
	Tumbler does not turn	Check capacitor and motor. Replace if failed.
	Door switch	Check door switch contacts and adjustment. Adjust or replace door switch.
	Timer Tumbler does not turn	Check to see if heat timer is turned on.
Tumbler turns but no spark at burner	Glass fuse	Check small glass control fuse in back of dryer. Replace if failed.
	Thermostat	Check if voltage is passing through the two wires attached to the temperature thermostat
	Ignition	Check for 24VAC output from transformer.
	Transformer	Replace if have 120VAC between black & white and no 24VAC between red and yellow.
	Over temperature	Check to see if manually resettable thermostat. Thermostat is kicked out. Reset by pushing red reset button.
	Ignition control	Check for 24VAC coming into the control on the at burner red wire. If voltage, then check for 24VAC out on the brown wire. Also check for spark at the ignitor. If no 24VAC output or no spark to the ignitor, replace ignition control.
	Air Flow Switch	Check air flow switch to be sure it closes when dryer is running. If not, adjust or replace switch.
	Hi-limit	Check for continuity. Should be 0 ohms resistance when cold. If not, replace thermostat.
	Gas supply	No gas can cause system lockout.

Dryer Trouble Shooting

Symptom	Probable Cause	Suggested Remedy
Tumbler turns, ignition sparks, no flame	Gas supply	Make sure gas supply is working.
	Gas pressure	Make manometer check of gas pressure. Adjust if necessary.
	Spark Electrode Sensor	Check for damage to electrode or mounting. Replace if necessary.
	Gas valve	Check coil continuity, replace valve if failed.
	Ignition Control	Check for 24VAC to gas valve coils. If no voltage replace ignition control.
Burner Lights, but goes on and off	Electrodes	Check low voltage harness for possible wire break or cuts to allow no signal back to ignition control.
Slow drying	Temperature Setting	Check thermostat for correct high temperature setting. Adjust if necessary.
	Air flow restrictions necessary	<ol style="list-style-type: none"> 1. Check lint screen and clean if necessary. 2. Check exhaust for correct length and clean if necessary. 3. Check exhaust damper to insure that it opens when dryer is running and closes when dryer is not in use. 4. Check makeup air to insure that it is adequate. Increase makeup air if necessary. 5. Check static Back pressure no more than .3
Manual overtemp Tripping Frequently	Recirculating chamber Lint Accumulation	Remove manual overtemp thermostat and inspect in chamber for excessive lint build up. Access also gained to this chamber by removing recirculation duct mounted at bottom of chamber, or the panel inside burner chamber between burners and rear back panel.
	Exhaust ducting Excessive lint buildup	Remove exhaust duct at rear of dryer and inspect for excessive lint build up in complete duct from dryer to where duct exits building.
	Clean lint from top heat air chamber above tumbler	Remove front panel completely. Be careful of any wiring attached. Remove heated air chamber cover and clean above tumbler back to burner housing.

Error Codes

Symptom	Probable Cause	Suggested Remedy
TEMP SENSOR SHORT	Shorted Temperature Sensor or wire.	The dryer control shall not start until the detected short circuit is removed. Regardless of condition of short circuit, Error Code will be displayed until programming button is pressed to return machine to idle mode.
TEMP SENSOR OPEN	Open Temperature Sensor or wire	The dryer control shall not start until the detected short circuit is removed. Regardless of condition of short circuit, Error Code will be displayed until programming button is pressed to return machine to idle mode.
PCB ERROR1	Memory corrupted	Power machine down and try to reset control. Verify voltage to the control board. Check ground to board. Replace control board if error can not be cleared.
PCB ERROR2	Analog/ Digital Error	Power machine down and try to reset control. Verify voltage to the control board. Check ground to board. Replace control board if error can not be cleared.
COMM ERROR1	Communication Bus Error	Power machine down and try to reset control. Verify voltage to the control board. Check ground to board. Replace control board if error can not be cleared.
COMM ERROR2	No Dryer Model Selected	This error occurs when a pin combination on the model selection header is used that does not have a model designated for it. check connector marked Jumpers on the control board.
COMM ERROR7	Communication Bus Error	If connected to DexterLive, Disconnect cable, and preform a soft restart by holding down the program button on power up. Preform Soft restart. contact your Dexter factory representative.
Fuse Error	Internal Control program Error.	Internal IC issue. Replace control.
CRC ERROR	Firmware Corrupted	The error is fatal. The control must be replaced.

Kits, Assemblies, & Common Parts

DC0030__-10
DC0050__-10
DC0080__-10

Description	T-30	T-50	T-80
Optical Coin Switch	9801-099-002	9801-099-002	9801-099-002
Kit - T80 Bottom exhaust			9732-348-001
Kit - 9873-008-001 w/ bearings & tolerance ring			9732-329-001
Kit - A to C series Conversion, Black, 120v	9732-307-002	9732-307-002	9732-307-002
Kit - A to C series Conversion, Blue, 120v	9732-307-001	9732-307-001	9732-307-001
LP to Natural Conversion Kit for White Rodgers	9732-142-004	9732-142-004	9732-142-004
Coin Acceptor switch kit w/ extra actuator	9732-126-001	9732-126-001	9732-126-001
Kit, Optional Replacement for Round Switch 9539-492-001	9732-351-001	9732-351-001	9732-351-001
Temperature Probe	9501-004-002	9501-004-002	9501-004-002
Controls	9471-022-001	9471-022-001	9471-022-001
Coin Drop	9021-093-001	9021-093-001	9021-093-001
Coin Drop Screws	9545-053-002	9545-053-002	9545-053-002
Ignition Control Box	9857-182-001	9857-182-001	9857-182-001
Electrode Assembly, Ignition	9875-002-003	9875-002-003	9875-002-003
Thermostat, Hi-Limit	9576-203-002	9576-203-002	9576-203-002
Thermostat, Overtemp	9576-207-006	9576-207-006	9576-207-006
Motor Run Relay	5192-299-002	5192-299-002	5192-299-002
Transformer, Ignition	8711-007-002	8711-007-002	8711-007-002
Lint Screen Assembly	9822-026-002	9822-026-001	9822-031-002
Air Flow Switch	9029-174-001	9029-200-001	9029-200-001
Switch-Door Closure (Square)	9539-501-001	9539-501-001	9539-501-001
Switch-Door Closure (Round)	9539-492-001	9539-492-001	9539-492-001
Motor Belt	9040-076-003	9040-076-006	9040-076-011
Tumbler Belt	9040-073-009	9040-073-011	9040-073-012
Tension Arm Complete	9861-002-001	9861-002-002	9861-024-004
Spider/Trunnion	9568-015-001	9568-013-001	9873-008-001
Door Handle	9244-082-001	9244-082-001	9244-082-001
Run Capacitor		5191-108-001	5191-108-001
Start Capacitor		5191-109-001	5191-109-001
Cleanout Duct Assembly 8"	9973-034-001	9973-034-001	9973-034-001



Section 5: Dryer Parts Data

DC0030__-10
DC0050__-10
DC0080__-10

Starting Serial Number D1.15224.001

Key	Description	T-30	T-50	T-80	QTY
1	Loading Door Complete SS/Brushed SS/Blk	9960-306-001	9960-305-001	9960-305-001	1
1	Loading Door Complete Wht/Brushed SS/Blk	9960-306-003	9960-305-003	9960-305-003	1
2	Door Assy, Loading (Ring only) Brushed SS	9960-255-008	9960-284-002	9960-284-002	1
3	Plate Assy, Hinge (SS)	9982-374-001	9982-368-001	9982-368-001	1
3	Plate Assy, Hinge (Wht)	9982-374-003	9982-368-003	9982-368-003	1
*	Cover-Hinge Back, Black	9074-341-002	9074-340-002	9074-340-002	1
*	Screw-10Bx3/8, Black	9545-008-010	9545-008-010	9545-008-010	2
*	Screw Hinge to Door	9545-012-015	9545-012-015	9545-012-015	4
*	Nut, Hinge to Door	8640-413-002	8640-413-002	8640-413-002	4
4	Glass, Door	9212-002-003	9212-002-004	9212-002-004	1
5	Gasket, Door Glass (Black)	9206-413-001	9206-413-002	9206-413-002	1
*	Support Door Glass	9548-117-000	9548-117-000	9548-117-000	2
6	Gasket, Door Outer Rim (Black)	9206-420-003	9206-420-005	9206-420-005	1
7	Handle, Loading Door	9244-082-001	9244-082-001	9244-082-001	1
*	Screw, Handle	9545-018-017	9545-018-017	9545-018-017	2
8	Stud Door Catch	9531-033-001	9531-033-002	9531-033-002	1
9	Nut-Hex, #10-32	8640-413-001	8640-413-001	8640-413-001	1
10	Nut, Acorn	8640-413-003	8640-413-003	8640-413-003	1
*	Catch, Loading Door	9086-015-002	9086-015-002	9086-015-002	2
*	Rivit	8638-190-009	8638-190-009	8638-190-009	4
11	Strap, Hinge (Black)	9966-018-002	9966-014-002	9966-014-002	1
*	Plate Assy-Backup, Hinge	9982-371-001	9982-356-001		1
*	Plate Assy-Backup, Hinge	9982-368-001		9982-369-001	1
*	Reinforcement-Front panel			9817-003-001	1
12	Screw-Phillips, 10-32x1/2 Chrome	9545-012-003	9545-012-003	9545-012-003	4
*	Screw-Phillips-Counter sink, 10-32x1/2 Chrome	NA	9545-012-028	9545-012-028	4
13	Screw-Special, Hinge to Door	9545-052-001	9545-052-001	9545-052-001	1
*	Nut-Allen, 1/4-20	8640-439-001	8640-439-001	8640-439-001	1
14	Washer-Fiber/Plastic	8641-436-003	8641-436-003	8641-436-003	1
15	Front Panel Assy (SS) Round Switch	9454-917-001	9454-865-001	9454-867-001	1
15	Front Panel Assy (SS) Square Swtich	9444-001-001	9444-003-001	9444-005-001	1
15	Front Panel Assy (Wht) Round Switch	9454-917-003	9454-865-003	9454-867-003	1
15	Front Panel Assy (Wht) Square Switch	9444-001-003	9444-003-003	9444-005-003	1
16	Screw-Phillips, 10Bx1 3/4	9545-008-014	9545-008-014	9545-008-014	4
17	Washer-Finish	8641-585-001	8641-585-001	8641-585-001	4
*	Nut-Spring (Before Serial)	8640-399-001	8640-399-001	8640-399-001	4
*	Nut, Expansion (After Serial D1.21187.042)	8640-442-001			4
*	Nut, Expansion (After Serial D1.21162.038)		8640-442-001		4
*	Nut, Expansion (After D1.21177.005)			8640-442-001	4
*	Insulation-Front Panel, Top Half	9277-063-001	9277-057-001	9277-058-001	1
*	Insulation-Front Panel, Bottom Half	9277-063-002	9277-057-001	9278-058-002	1
*	Switch-Door Closed (Square)	9539-501-001	9539-501-001	9539-501-001	1
*	Switch-Door Closed (Round)	9539-492-001	9539-492-001	9539-492-001	1
*	Wire-Assy, Blk	8220-063-026	8220-063-026	8220-063-026	1
*	Wire-Assy-Blu	8220-063-009	8220-063-009	8220-063-009	1

Dryer Cabinet Group

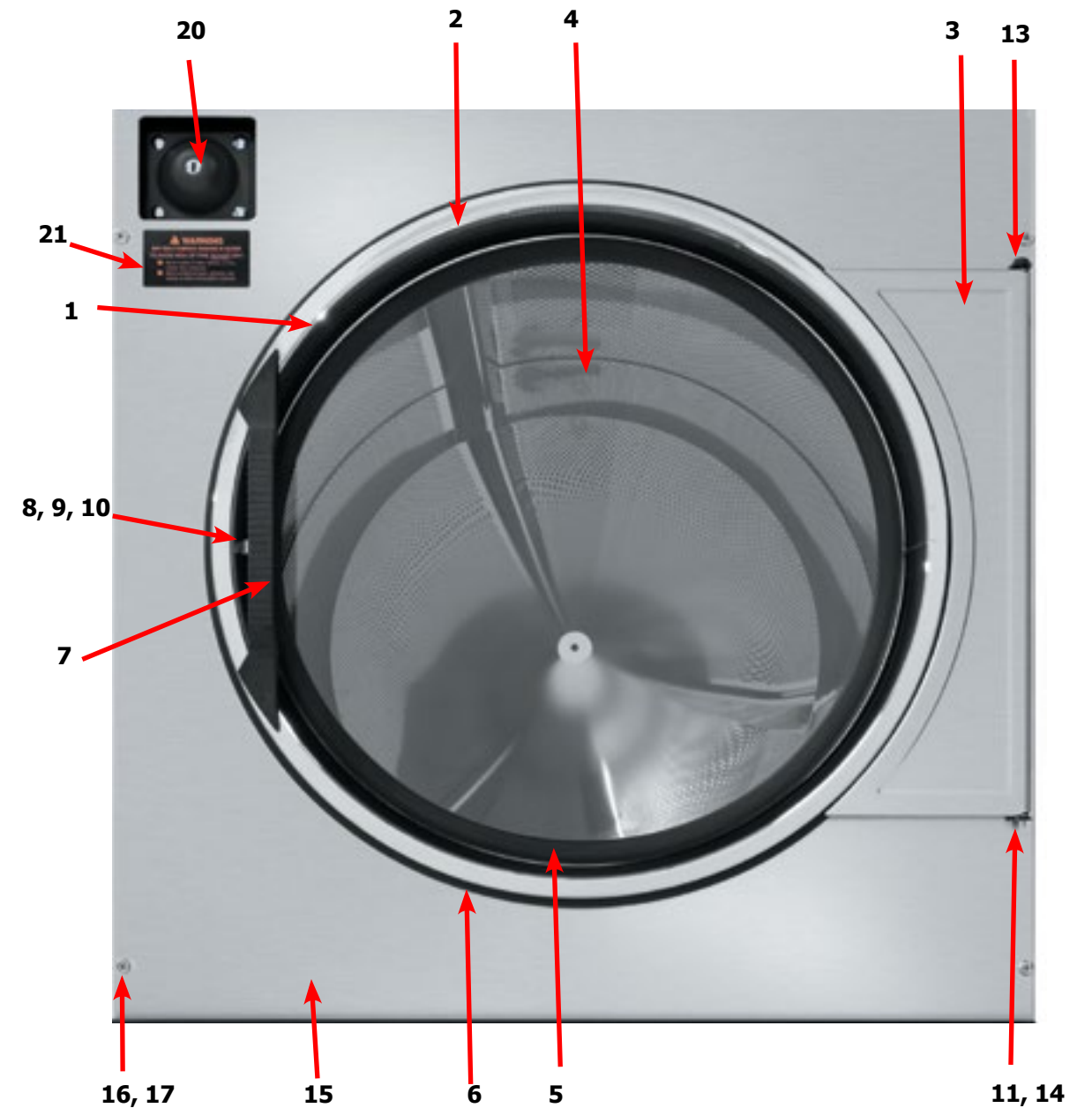

Key	Description	T-30	T-50	T-80	QTY
20	Coin Box Blue	9807-099-002	9807-099-002	9807-099-002	1
20	Coin Box Black	9807-099-004	9807-099-004	9807-099-004	1
21	Label-Warning, Dryer (Blue)	8502-758-002	8502-758-002	8502-758-002	1
21	Label-Warning, Dryer (Black)	8502-758-001	8502-758-001	8502-758-001	1
*	Label-Warning, French, Spanish	8502-764-001	8502-764-001	8502-764-001	1
*	Cabinet Touch Up Paint (White)	9472-001-013	9472-001-013	9472-001-013	1

Dryer Cabinet Group Continued

Key	Description	T-30	T-50	T-80	QTY
1	Nameplate - Dexter Dryer Blue	9412-216-002	9412-216-002	9412-216-002	1
1	Nameplate - Dexter Dryer Black	9412-216-001	9412-216-001	9412-216-001	1
2	Door Assy-Upper, Coin (SS)	9960-311-001	9960-312-001	9960-313-001	1
2	Door Assy-Upper, Coin (Wht)	9960-311-003	9960-312-003	9960-313-003	1
3	Bracket-Hinge	9029-224-001	9029-224-001	9029-224-001	2
*	Rivet- 3/16, Hinge to Door	9491-009-001	9491-009-001	9491-009-001	2
*	Rivet- 3/16, Hinge to Cabinet	9491-009-001	9491-009-001	9491-009-001	AR
4	Trim-Upper Service Door, Black	9578-098-002	9578-094-002	9578-096-002	1
5	Screw-Phillips, 10Bx3/8, Black	9545-008-010	9545-008-010	9545-008-010	4
6	Lock Assy. and Key Upper	8650-012-003	8650-012-003	8650-012-003	1
7	Cam Lock Upper Door	9095-047-001	9095-047-001	9095-047-001	1
*	Lock Spacer	9538-189-001	9538-189-001	9538-189-001	*
*	Key, 6324	6292-006-007	6292-006-007	6292-006-007	1
8	Overlay-Control, Coin, Blue	9435-042-002	9435-046-002	9435-047-002	1
8	Overlay-Control, Coin, Black	9435-042-001	9435-046-001	9435-047-001	1
9	Button-Push, Control, Blue	9035-062-001	9035-062-001	9035-062-001	1
9	Button-Push, Control, Black	9035-062-002	9035-062-002	9035-062-002	1
*	Spacer-Push Button (Micro)	9538-192-001	9538-192-001	9538-192-001	2
*	Retainer-Push Button (Micro)	9486-150-001	9486-150-001	9486-150-001	2
*	Nut, Hex-Elastistop, #4-40	8640-424-002	8640-424-002	8640-424-002	2
10	PCB-Controller	9471-022-001	9471-022-001	9471-022-001	1
*	Spacer-#6 x 9/16	9538-157-018	9538-157-018	9538-157-018	3
*	Spacer #6 x 7/8	9538-157-017	9538-157-017	9538-157-017	2
*	Nut- #6-32	8640-411-003	8640-411-003	8640-411-003	4
	Nut- #6-32 (Grounding nut)	8640-411-001	8640-411-001	8640-411-001	1
11	Wire Assy-GRN, 24"	8220-137-001	8220-137-001	8220-137-001	1
*	Harness, Main	9627-912-001	9627-912-002	9627-912-003	1
12	Support-Upper Service Door	9548-288-001	9548-288-002	9548-288-002	1
13	Clamp-Tube	9079-121-002	9079-121-002	9079-121-002	2
14	Nut, #6-32	8640-411-003	8640-411-003	8640-411-003	2
15	Clamp-Cable, 1/2"	8654-125-006	8654-125-006	8654-125-006	1
*	Nut, #6-32	8640-411-003	8640-411-003	8640-411-003	1
16	Insulation	9277-041-016	9277-041-016	9277-041-016	1
17	Coin Acceptor	9021-093-001	9021-093-001	9021-093-001	1
18	Retainer-Coin Acceptor	9486-149-001	9486-149-001	9486-149-001	2
19	Screws-Torq, 4Bx5/8 ss	9545-053-002	9545-053-002	9545-053-002	4
*	Switch Assembly, Optical	9801-099-001	9801-099-001	9801-099-001	1
*	Coin Chute	9940-017-001	9940-017-001	9940-017-001	1
*	Screw	9545-008-001	9545-008-001	9545-008-001	1
*	Thumb Drive	9150-045-002	9150-045-002	9150-045-002	1
*	Nut, Elastic Stop	8640-413-004	8640-413-004	8640-413-004	*

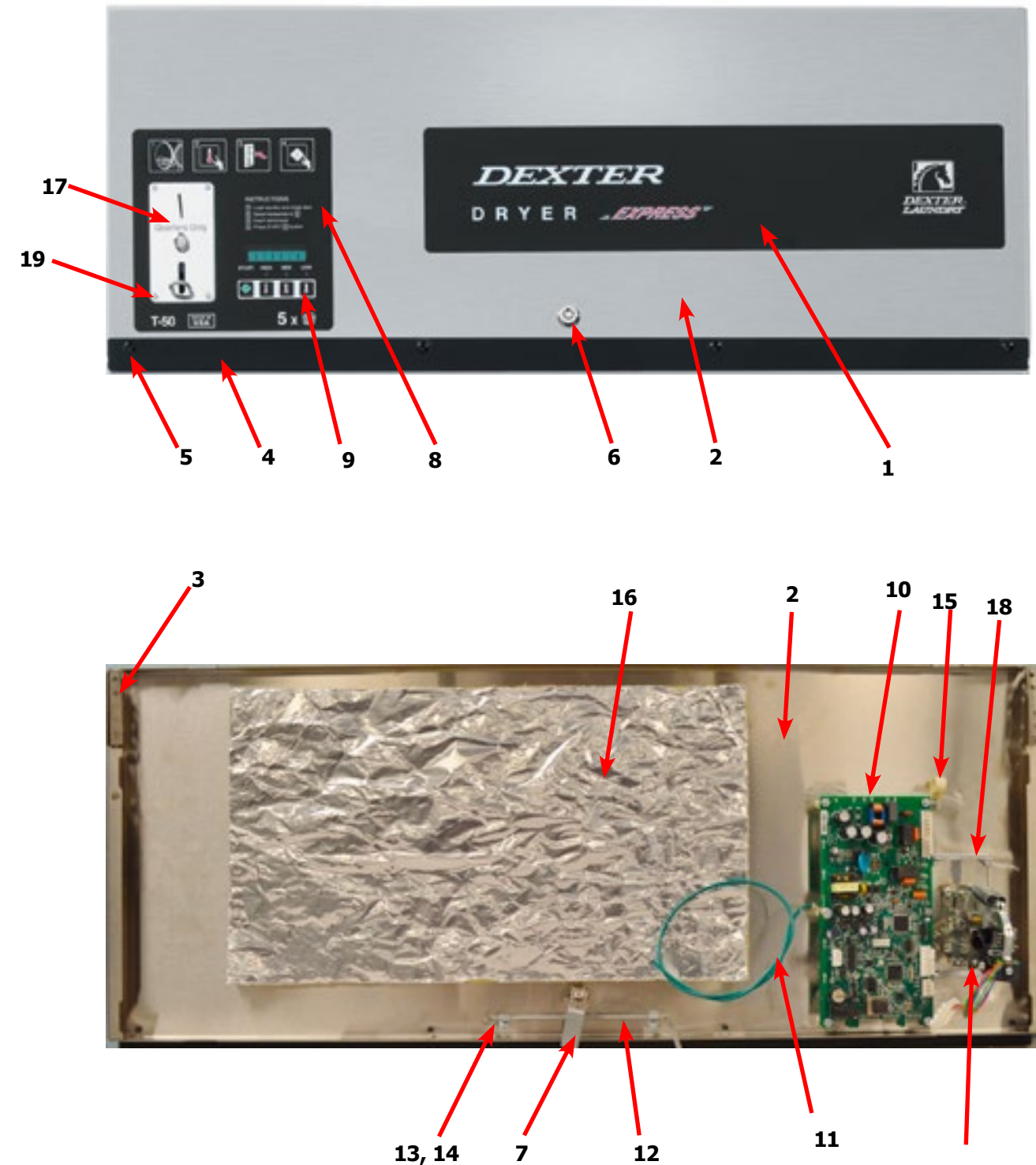

Dryer Cabinet Group Continued

Key	Description	T-30	T-50	T-80	QTY
1	Door-Lower Service, Coin, SS	9108-130-001	9108-122-001	9108-126-001	1
1	Door-Lower Service, Coin, Wht	9108-130-003	9108-122-003	9108-126-003	1
2	Lock Assy. and Key Lower Door	8650-012-004	8650-012-004	8650-012-004	1
*	Cam Lock Lower Door	9095-048-001	9095-048-001	9095-048-001	1
*	Lock Spacer	9538-189-001	9538-189-001	9538-189-001	*
*	Washer-Flat	8641-581-041	8641-581-041	8641-581-041	2
3	Handle-Door, Lower Service	9244-084-002	9244-087-002	9244-088-002	1
4	Screw-Phillips, 10Bx3/8, Black	9545-008-010	9545-008-010	9545-008-010	5
5	Trim-Lower Kick, Black	9578-099-002	9578-095-002	9578-097-002	1
6	Screw-Phillips, 10Bx3/8, Black	9545-008-010	9545-008-010	9545-008-010	4
7	Screen Assy, Lint	9822-026-002	9822-026-001	9822-031-002	1
8	Switch-Door Closure (Square)	9539-501-001	9539-501-001	9539-501-001	1
8	Switch-Door Closure (Round)	9539-492-001	9539-492-001	9539-492-001	1
*	Kit, Optional Replacement for Round Switch 9539-492-001	9732-351-001	9732-351-001	9732-351-001	1
9	Hinge-Door, Lower	9243-081-001	9243-082-001	9243-082-001	1
10	Screw-5/16, 10ABx3/8	9545-008-024	9545-008-024	9545-008-024	5
11	Bracket-Door Switch	9029-226-001	9029-226-001	9029-226-001	1
*	Rivet, 1/8 Low Profile	9491-009-004	9491-009-004	9491-009-004	2
12	Bracket-Chain	9029-223-001	9029-223-001	9029-223-001	2
*	Rivet, 1/8 Low Profile	9491-009-004	9491-009-004	9491-009-004	8
13	Hook, "S" Type	9248-022-002	9248-022-002	9248-022-002	4
14	Chain	9099-012-006	9099-012-006	9099-012-006	2
*	Leg, Leveling 1/2"	8544-006-001	8544-006-001	8544-006-001	4

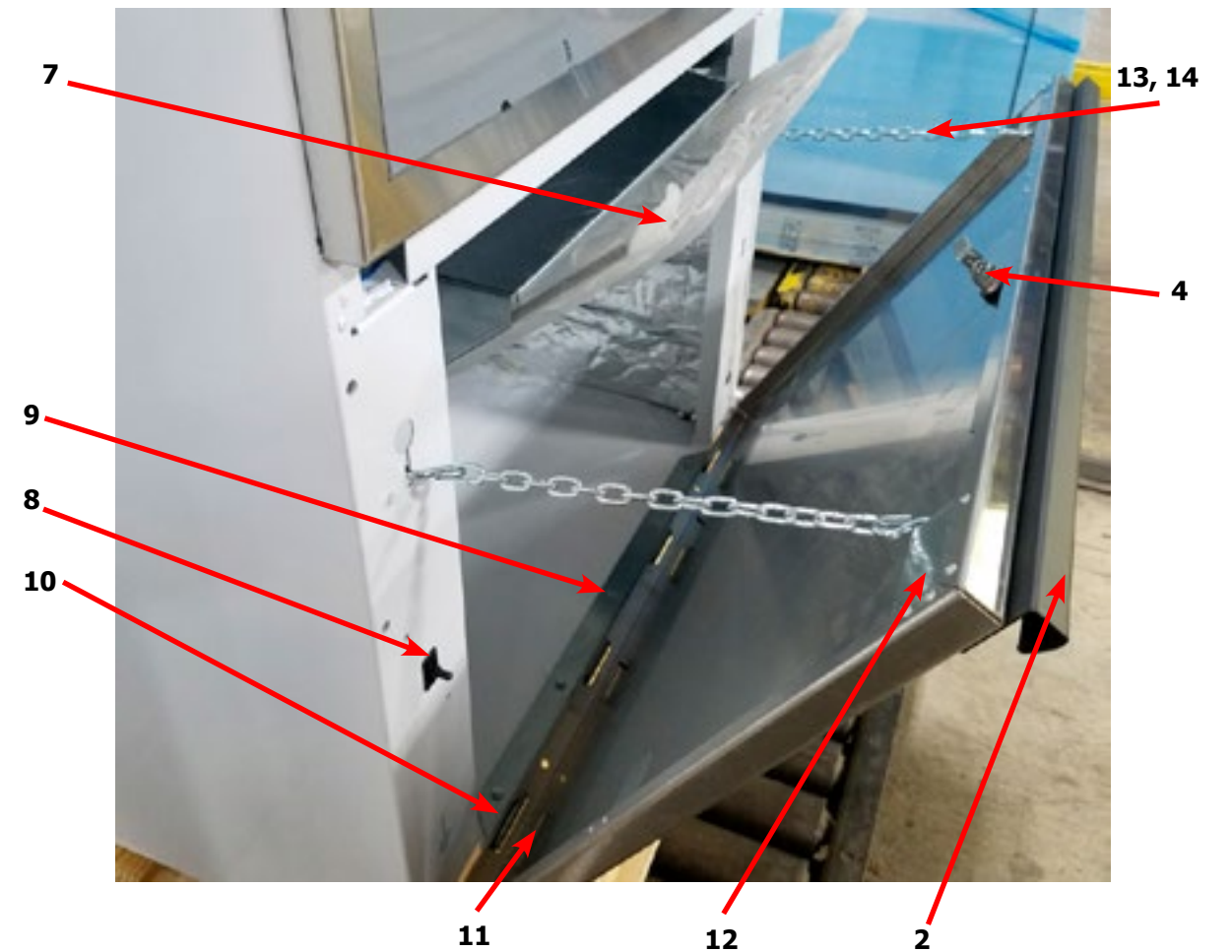
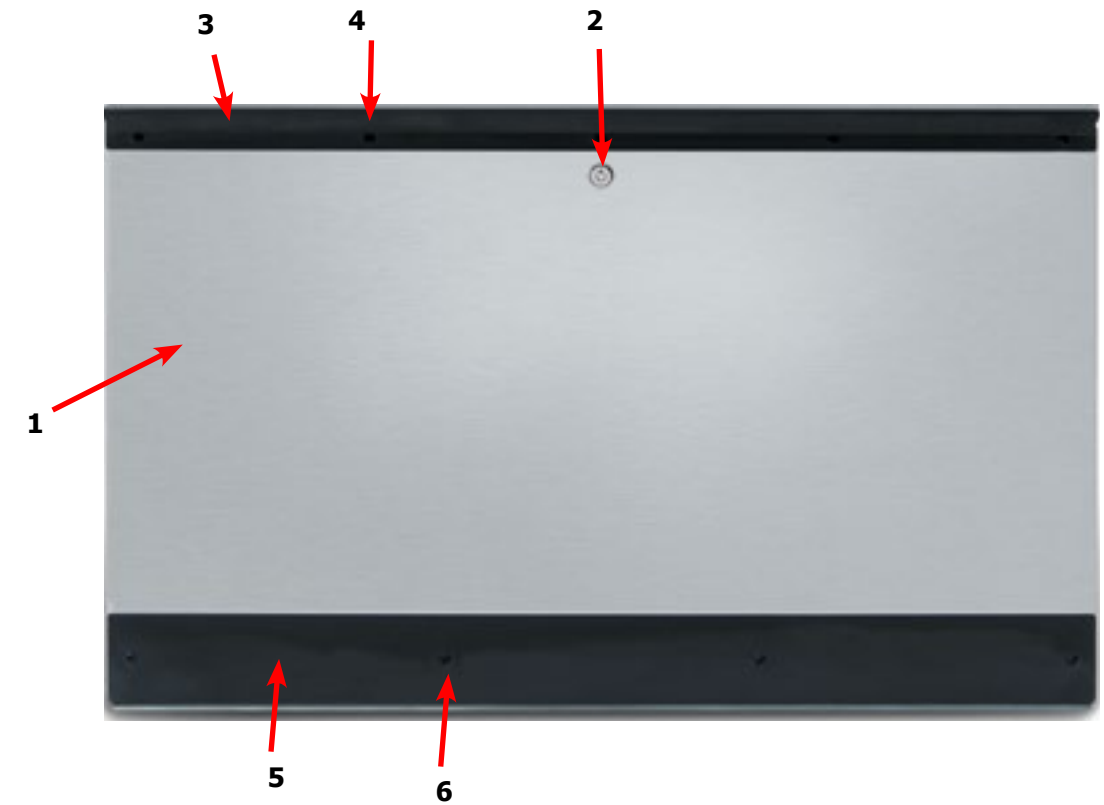

Dryer Cabinet Group Continued

Key	Description	T-30	T-50	T-80	QTY
1	Insulation, Upper service Door	9277-041-006	9277-041-016	9277-041-016	1
2	Insulation, RH Burner	9277-041-019	9277-041-019	9277-041-023	1
3	Insulation Tumbler Area, above Baffle	9277-041-020	9277-051-003	9277-041-021	2
3	Insulation Tumbler Area, above Baffle		9277-051-003	9277-041-021	2
4	Insulation Tumbler Area, below baffle	9277-041-020	9277-051-003	9277-051-004	2
4	Insulation Tumbler Area, below baffle		9277-051-003	9277-051-004	2
5	Insulation Lint Compartment	9277-041-021	9241-041-024	9277-041-025	2
*	Screen Assy, Lint	9822-026-002	9822-026-001	9822-031-002	1
6	Switch-Door Closure (Round)	9539-492-001	9539-492-001	9539-492-001	1
6	Switch-Door Closure (Square)	9539-501-001	9539-501-001	9539-501-001	1
7	Hinge-Door, Lower	9243-081-001	9243-082-001	9243-082-001	1
8	Screw-5/16, 10ABx3/8	9545-008-024	9545-008-024	9545-008-024	AR
9	Lint Hood-Back	9240-038-001	9240-041-001	9240-044-001	1
10	Nut Wizlock, 8-32	8640-412-004	8640-412-004	8640-412-004	6
11	Lint hood, LH	9240-040-001	9240-043-001	9240-046-001	1
12	Lint hood, RH	9240-040-002	9240-043-002	9240-046-002	1
13	Lint hood, Top	9240-039-001	9240-042-001	9240-045-001	1
14	Screw, 5/16- 10ABx3/8	9545-008-024	9545-008-024	9545-008-024	14
15	Impeller, w/ set screws	9278-043-001	9278-038-004	9278-037-003	1
16	Harness -Temp Probe	9627-679-002	9627-679-002	9627-679-002	1
17	Wire Nut, #71B	8640-276-005	8640-276-005	8640-276-005	2
18	Bracket, Temp Probe	9029-197-001	NA	NA	1
19	Screw-5/16, 10ABx3/8	9545-008-024	NA	NA	1
20	Temp Probe	9501-004-002	9501-004-002	9501-004-002	1
21	Screw-Phillips, 8Bx1/4	9545-045-005	9545-045-005	9545-045-005	1
22	Vault, Coin	9942-039-002	9942-039-002	9942-039-002	1
*	Plate Assy./Coin vault mounting	9982-338-001	9982-338-001	9982-338-001	1
*	Nut/ Hex elastic stop	8640-413-004	8640-413-004	8640-413-004	2
23	Coin Chute	9940-017-001	9940-017-001	9940-017-001	1
*	Screw, 10Bx1/4	9545-008-001	9545-008-001	9545-008-001	1
24	Harness, Main	9627-912-001	9627-912-002	9627-912-003	1

30Lb. Temp Probe

50Lb. & 80Lb. Temp Probe

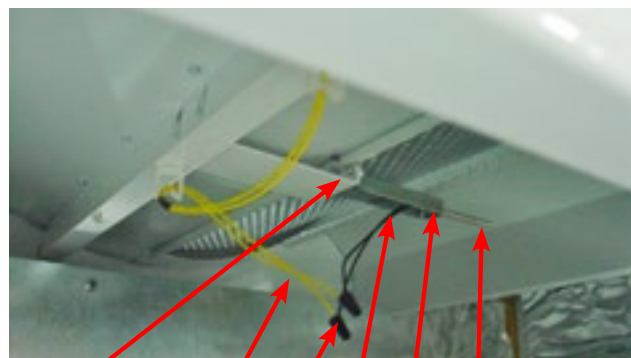

19 16 17 18 21 20

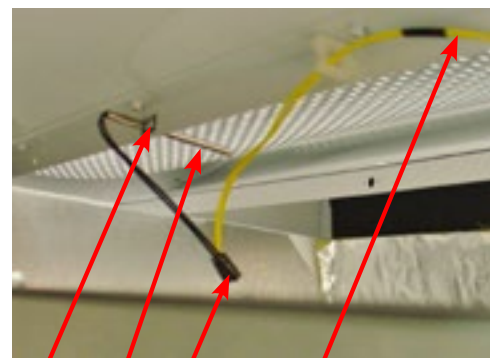

21 20 17 16

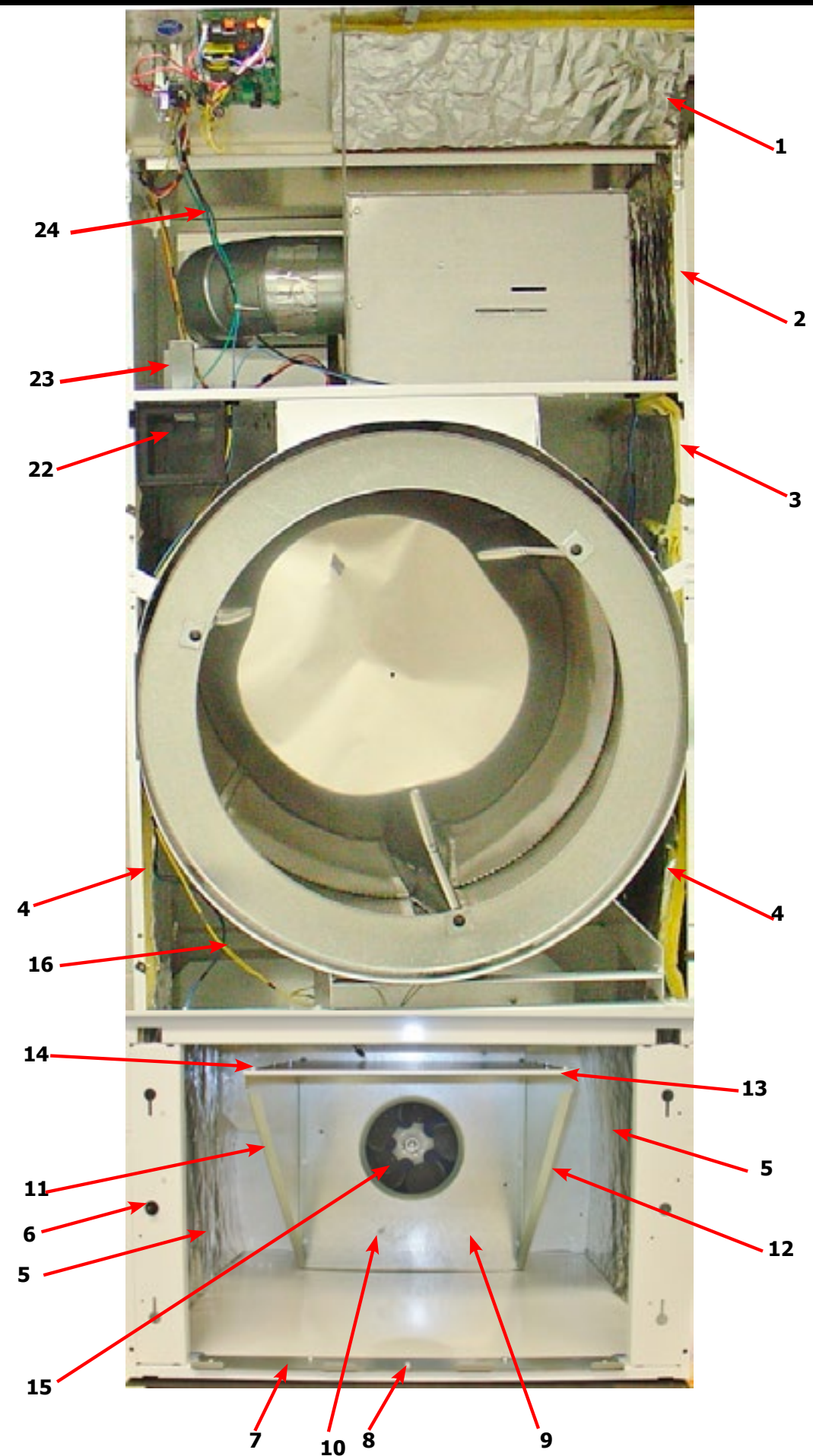

Dryer Modular Cabinet Group 30lb. (After Serial D1.23164.026)

Key	Description	T30	QTY
1	Cabinet Base Assembly	9945-166-001	1
*	Lower Back Panel Assembly	9989-730-002	1
2	Lower Cabinet RH Side Panel	9444-109-003	1
3	Lower Cabinet LH Side Panel	9444-109-004	1
4	Lower Cabinet Front Channel	9081-224-001	1
*	Upper Back Panel Assembly	9989-731-002	1
5	RH Middle Side Panel Assembly	9444-111-003	1
6	LH Middle Side Panel Assembly	9444-111-004	1
7	Cabinet Top	9577-070-001	1
8	RH Baffle	9049-131-001	1
9	LH Baffle	9049-132-001	1
*	Baffle Angled Bracket	9029-371-001	2
10	RH Upper Side Panel	9444-113-003	1
11	LH Upper Side Panel	9444-113-004	1
12	Upper Cross Brace	9046-107-001	1
*	10abx3/8 Screw	9545-008-024	25
*	3/16 Blind Rivet	9491-009-001	171
*	Wht 3/16 Blind Rivet	9491-009-005	48

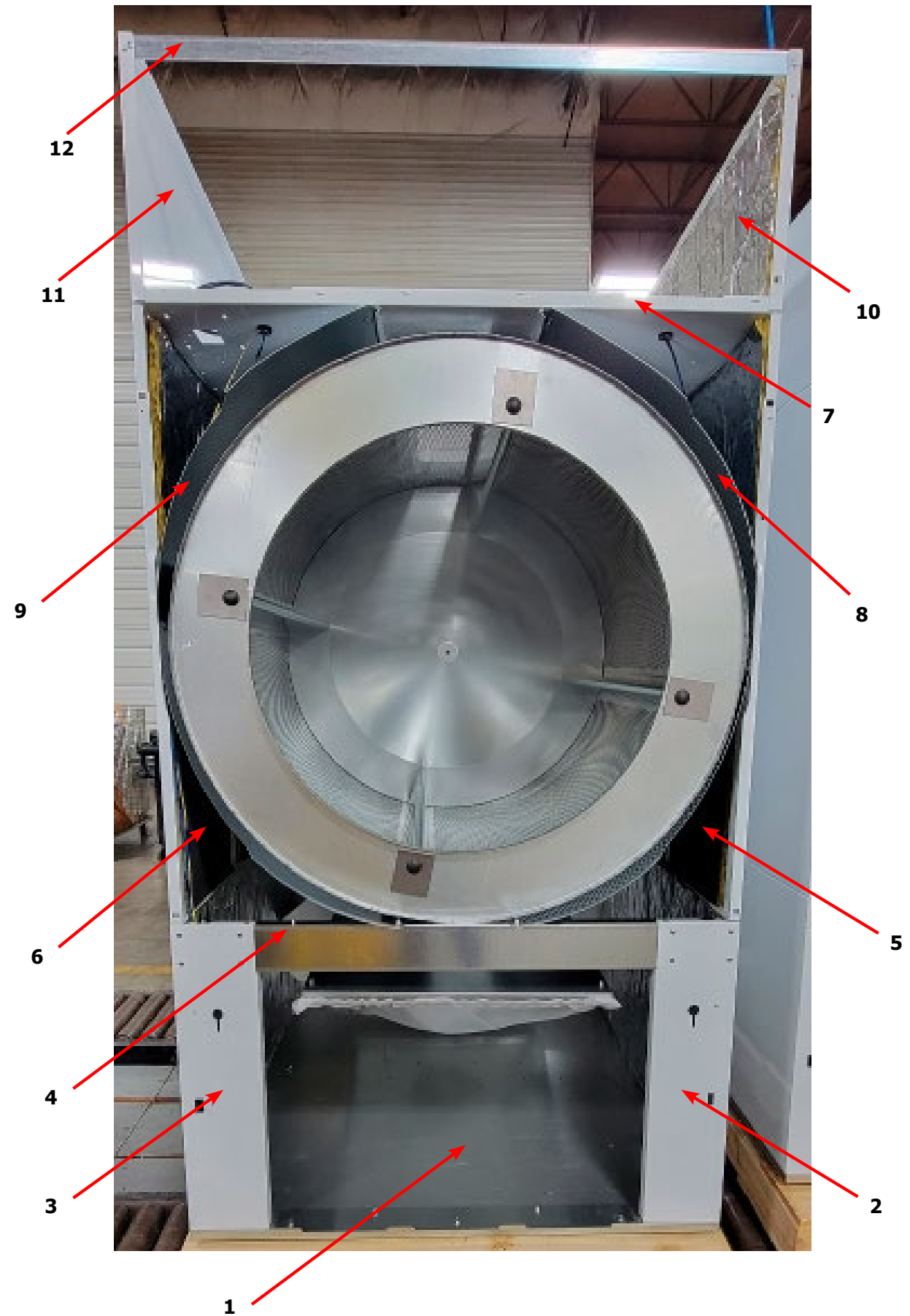

Dryer Modular Cabinet Group 50lb. (After Serial D1.23145.014)

Key	Description	T50	QTY
1	Cabinet Base Assembly	9945-165-001	1
*	Lower Back Panel Assembly	9989-726-002	1
2	Lower Cabinet RH Side Panel	9444-104-003	1
3	Lower Cabinet LH Side Panel	9444-104-004	1
4	Lower Cabinet Front Channel	9081-222-001	1
*	Upper Back Panel Assembly	9989-727-002	1
5	RH Middle Side Panel Assembly	9989-728-003	1
6	LH Middle Side Panel Assembly	9989-728-004	1
7	Cabinet Top Assembly	9961-164-001	1
8	RH Baffle	9049-130-001	1
9	LH Baffle	9049-130-002	1
*	Baffle Stiffener Angle	9003-386-001	2
10	RH Upper Side Panel	9444-108-003	1
11	LH Upper Side Panel	9444-108-004	1
12	Upper Cross Brace	9046-105-001	1
*	10abx3/8 Screw	9545-008-024	21
*	Large Head Pop Rivet	8638-190-028	4
*	3/16 Blind Rivet	9491-009-001	122
*	Wht 3/16 Blind Rivet	9491-009-005	54

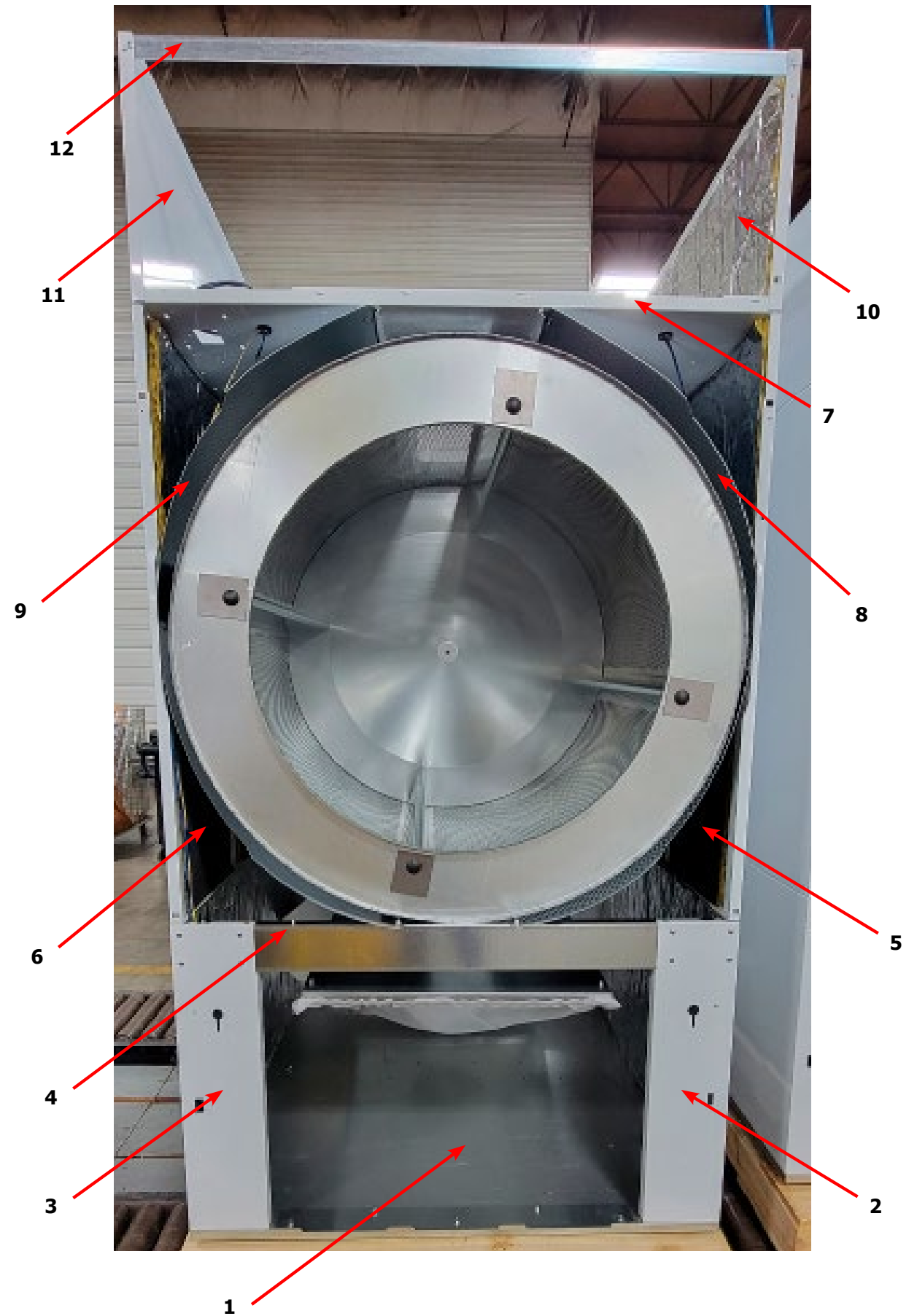

Dryer Modular Cabinet Group 80lb. (After Serial D1.23090.024)

Key	Description	T80	QTY
1	Cabinet Base Assembly	9945-162-001	1
*	Lower Back Panel Assembly	9989-716-002	1
2	Lower Cabinet RH Side Panel	9444-091-003	1
3	Lower Cabinet LH Side Panel	9444-091-004	1
4	Lower Cabinet Front Channel	9081-217-001	1
*	Upper Back Panel Assembly	9989-717-002	1
5	RH Middle Side Panel Assembly	9989-718-003	1
6	LH Middle Side Panel Assembly	9989-718-004	1
7	Cabinet Top Assembly	9961-163-002	1
8	RH Baffle	9049-129-001	1
9	LH Baffle	9049-129-002	1
*	Baffle Stiffener Angle	9003-384-001	2
10	RH Upper Side Panel	9444-095-003	1
11	LH Upper Side Panel	9444-095-004	1
12	Upper Cross Brace	9046-104-001	1
*	Heavy Hex Nut 7/16-14	8640-416-001	6
*	Spring Lockwasher 7/16	8641-582-013	6
*	10abx3/8 Screw	9545-008-024	28
*	Large Head Pop Rivet	8638-190-028	4
*	3/16 Blind Rivet	9491-009-001	111
*	Wht 3/16 Blind Rivet	9491-009-005	54
*	Hex kep Nut 1/4-20unc, 2b	8640-414-006	10
*	LH Rear Side Angle	9003-326-002	1
*	RH Rear Side Angle	9003-327-002	1

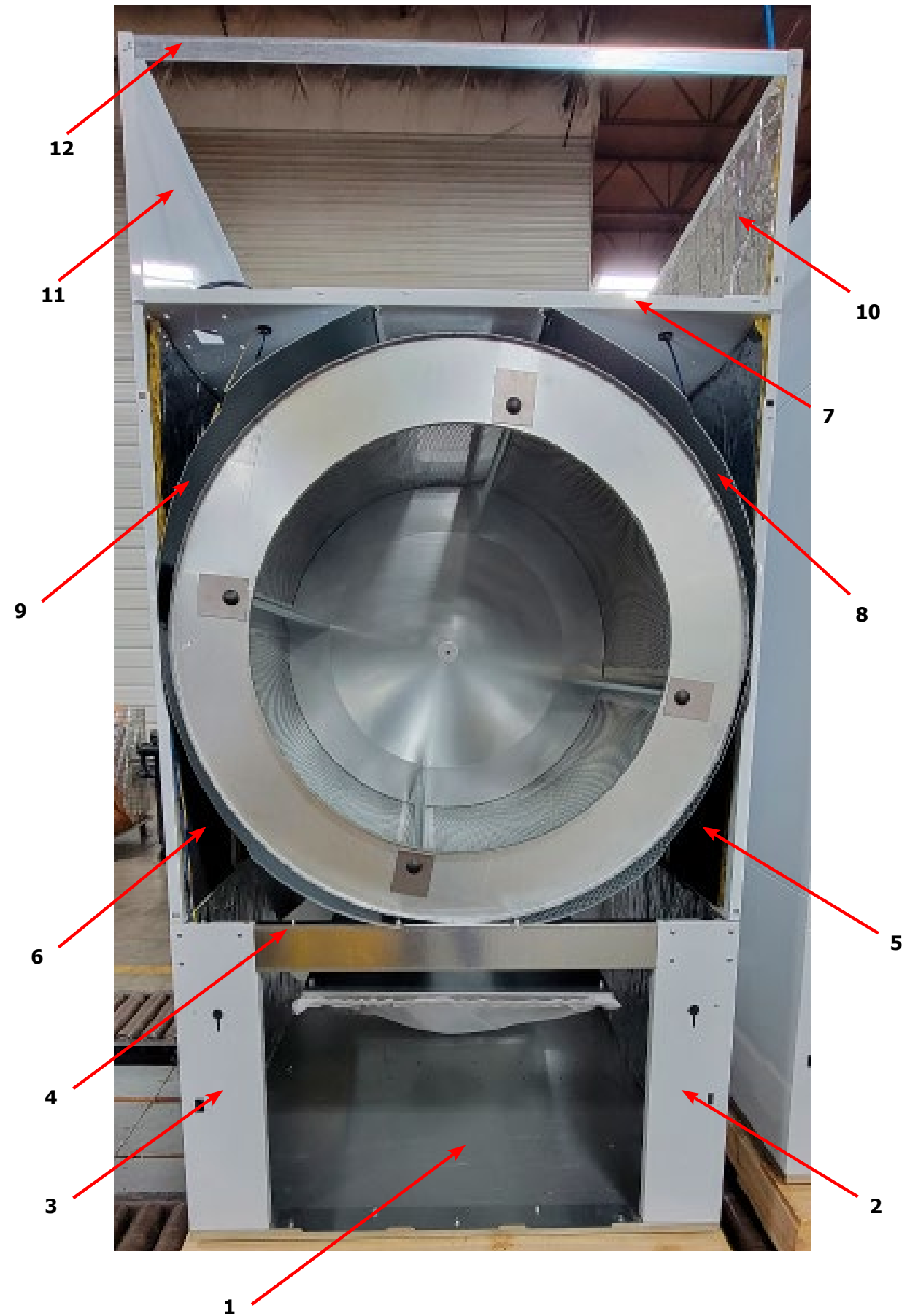

Dryer Rear View 30Lb

Key	Description	T-30	QTY
1	Motor	9376-311-003	1
2	Pulley	9453-157-001	1
*	Set screw	9545-028-013	1
3	Plate, Motor mounting	9982-370-002	1
*	Gasket, Motor Plate	9206-428-001	1
4	Nut-3/8-16, Plate to cabinet	8640-415-004	4
*	Impeller w/ set screw	9278-043-001	1
5	Screw, 5/16-18x5/8	9545-014-004	4
6	Nut, 3/8-16	8640-415-004	4
7	Support Arm, Intermediate pulley	9991-053-001	1
8	Bolt- 3/8-16x1 1/4	9545-029-010	3
9	Nut, Wizlock, 3/8x16	8640-415-004	3
*	Cap Screw, 3/8-16x1 1/2	9545-029-003	1
*	Snap Ring	9487-200-003	1
*	Washer-Flat, 3/8x1	8641-581-020	1
10	Idler Arm Assembly	9861-022-001	1
11	Washer-Flat, 3/8x1	8641-581-020	2
12	Pulley, Idler w/ Bearings	9908-039-004	1
13	Bearing, Bronze	9036-145-002	2
14	Snap Ring	9487-200-003	1
15	Hook "S" type	9248-022-002	3
16	Chain, Spring tension	9099-012-002	1
17	Spring, tension	9534-319-002	1
18	Chain, Limit	9099-012-007	1
19	Belt Drive	9040-076-003	1
*	Tolerance Ring	9487-234-005	1
20	Pulley, Driven	9908-049-002	1
21	Washer-Flat, 1/2	8641-581-021	1
22	Washer-Lock, Ext. tooth, 1/2	8641-582-016	1
23	Bolt-3/4, 1/2-13x1/14	9545-017-019	1
24	Belt, Driven	9040-073-009	1

Dryer Rear View 30Lb

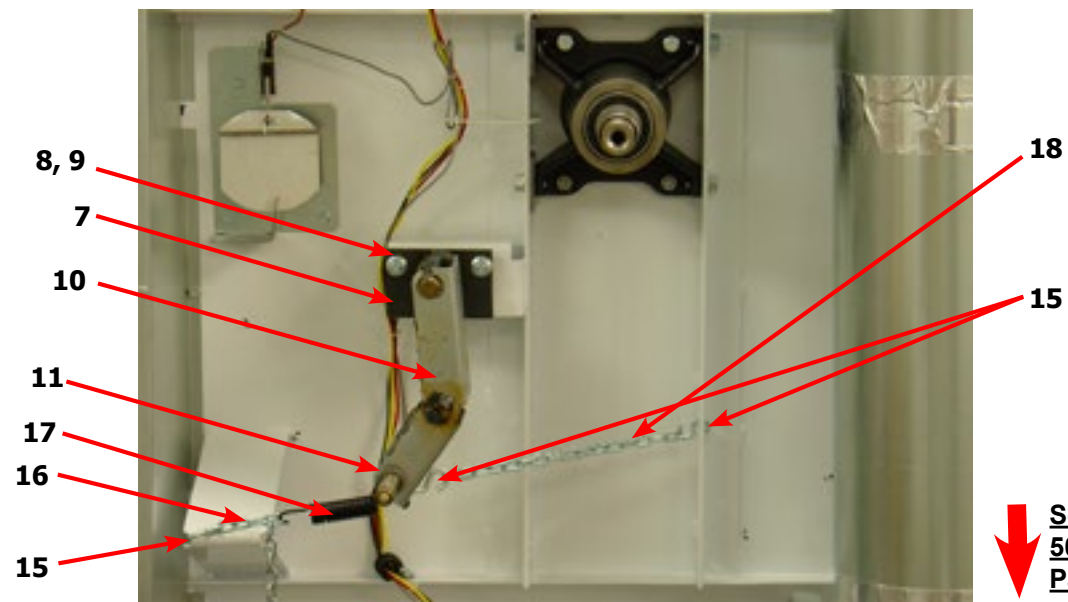
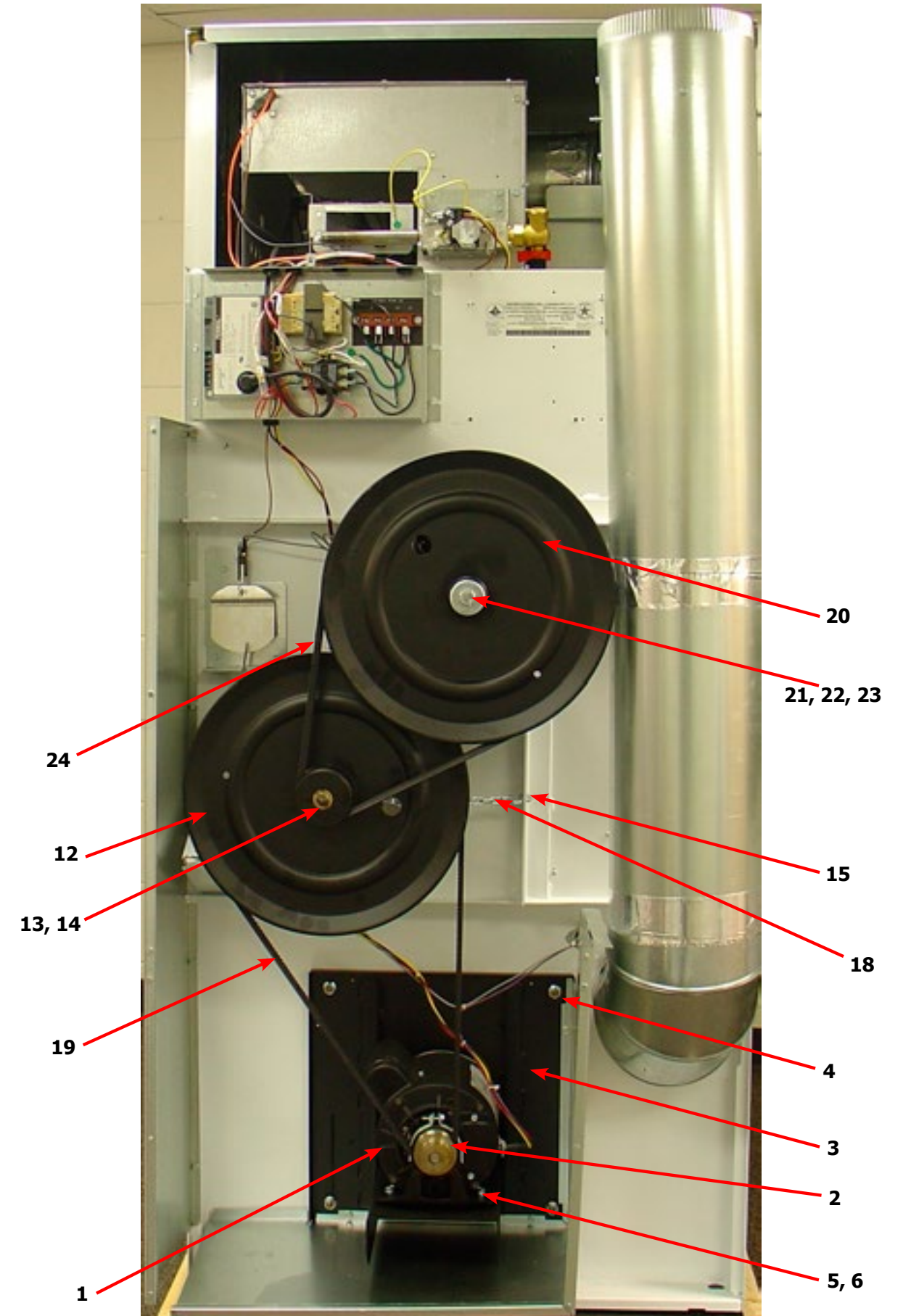

↓ Scroll down for
50lb and 80lb
Parts Breakdown

Dryer Rear View 50 Lb

Key	Description	T-50	QTY
1	Motor	9376-317-003	1
*	Run Capacitor, Motor	5191-108-001	1
*	Start Capacitor, Motor	5191-109-001	1
2	Pulley	9453-169-013	1
*	Set screw	9545-028-013	1
3	Plate, Motor mounting	9982-370-002	1
*	Gasket, Motor Plate	9206-428-001	1
4	Nut-3/8-16, Plate to cabinet	8640-415-004	4
*	Impeller w/ set screw	9278-038-004	1
5	Screw, 5/16-18x5/8	9545-014-004	4
6	Nut, 3/8-16	8640-415-004	4
7	Support Arm, Intermediate pulley	9991-053-002	1
8	Bolt- 3/8-16x1 1/4	9545-029-010	3
9	Nut, Wizlock, 3/8x16	8640-415-004	3
*	Cap Screw, 3/8-16x1 1/2	9545-029-012	1
*	Snap Ring	9487-200-003	1
*	Washer-Flat, 3/8x1	8641-581-035	1
10	Idler Arm Assembly	9861-022-002	1
*	Snap Ring (Support Arm keeper)	9487-200-003	1
*	Snap Ring	9487-200-003	1
*	Washer-Flat, 3/8x1	8641-581-035	1
11	Pulley, Idler w/ Bearings	9908-048-003	1
12	Bearing, Bronze	9036-145-002	2
13	Snap Ring	9487-200-003	1
14	Hook "S" type	9248-022-002	3
15	Chain, Spring tension	9099-012-002	1
16	Spring, tension	9534-369-001	1
17	Belt Drive	9040-076-006	1
*	Tolerance Ring	9487-234-005	1
18	Pulley, Driven	9908-047-002	1
19	Washer-Flat, 1/2	8641-581-026	1
20	Washer-Lock, Ext. tooth, 1/2	8641-582-016	1
21	Bolt-3/4, 1/2-13x1/14	9545-017-009	1
22	Belt, Driven	9040-073-011	1
23	Thermostat-Overtemp, Reset	9576-207-006	1

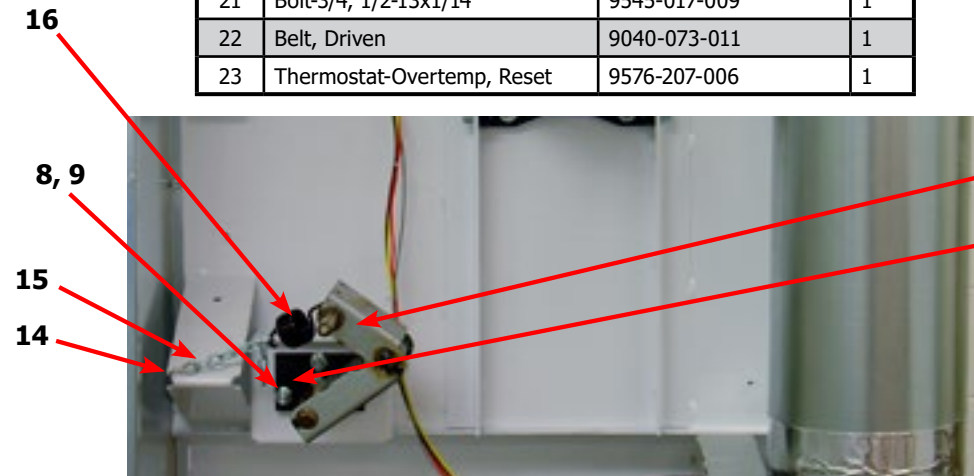

Scroll down for
80lb Parts
Breakdown

Dryer Rear View 50 Lb

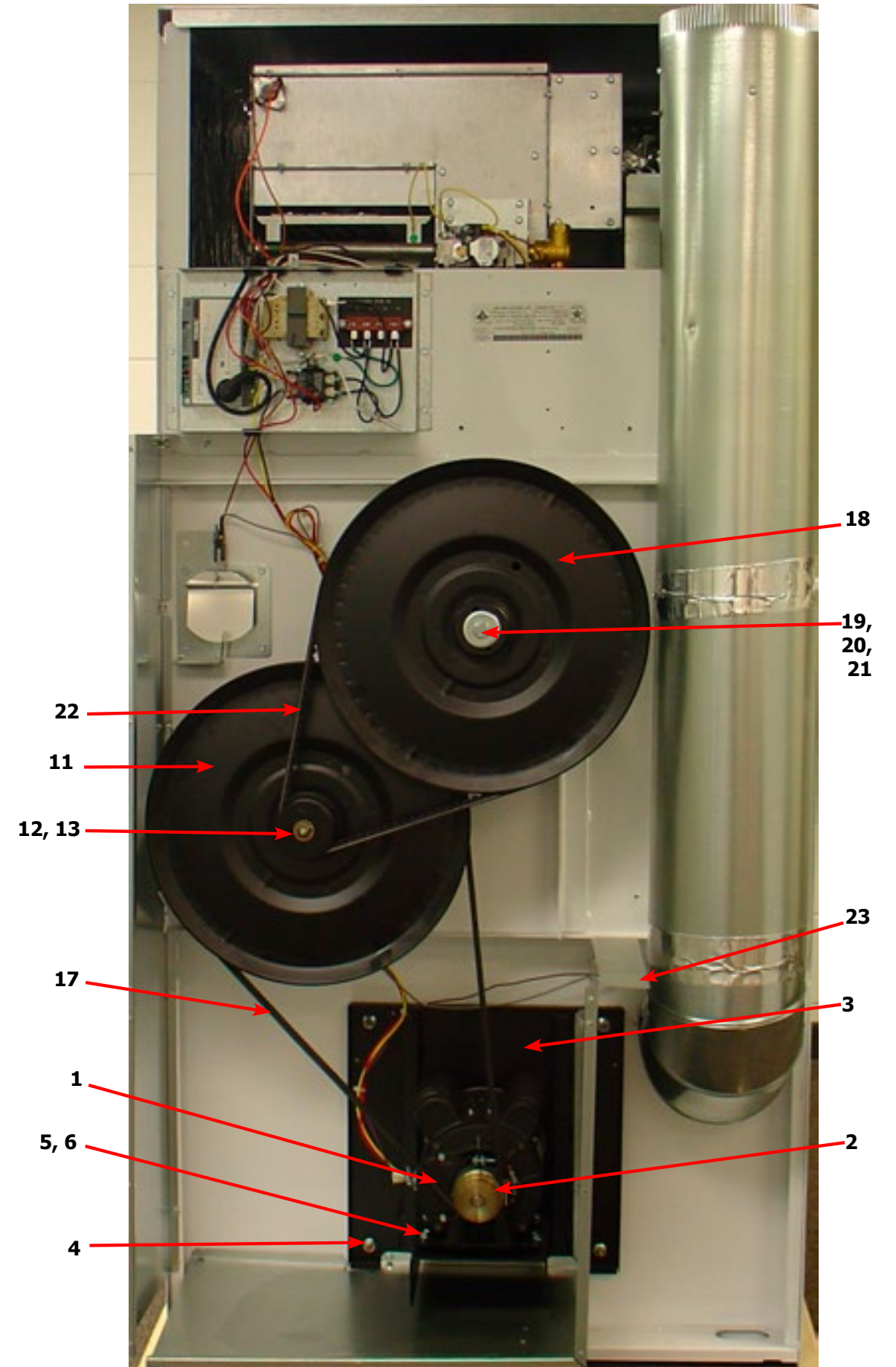

Dryer Rear View 80 Lb

Key	Description	T-80	QTY
1	Motor	9376-317-003	1
*	Run Capacitor, Motor	5191-108-001	1
*	Start Capacitor, Motor	5191-109-001	1
2	Pulley	9453-157-001	1
*	Set screw	9545-028-013	1
3	Plate, Motor mounting	9982-372-002	1
*	Gasket, Motor Plate	9206-428-001	1
4	Nut-3/8-16, Plate to cabinet	8640-415-004	4
*	Impeller w/ set screw	9278-037-003	1
5	Screw, 5/16-18x5/8	9545-014-004	4
6	Nut, 3/8-16	8640-400-003	4
*	Tolerance Ring	9487-234-001	1
7	Pulley, Driven	9908-043-002	1
8	Washer-Flat, 1/2	8641-581-026	1
9	Washer-Lock, Ext. tooth, 1/2	8641-582-016	1
10	Bolt-3/4, 1/2-13x1/4	9545-017-009	1
11	Support Arm, Intermediate pulley	9991-053-002	1
12	Bolt- 3/8-16x1 1/4	9545-029-010	3
13	Nut, Wizlock, 3/8x16	8640-415-004	3
*	Cap Screw, 3/8-16x1 1/2	9545-029-002	1
*	Snap Ring	9487-200-003	1
*	Washer-Flat, 3/8x1	8641-581-020	1
14	Idler Arm Assembly	9861-024-004	1
*	Snap Ring	9487-200-006	
*	Washer-Flat, 3/8x1	8641-581-039	1
15	Pulley, Idler w /Bearings	9908-042-006	1
*	Snapring, Inside-Bearing	9487-238-005	1
*	Bearing, Ball	9036-159-007	2
*	Spacer, Bearing	9538-173-002	1
16	Washer-Flat	8641-581-039	1
17	Nut, 5/8-11	8640-425-002	1
18	Hook "S" type	9248-022-002	3
19	Chain, Spring tension	9099-012-002	1
20	Spring, tension	9534-369-001	1
21	Belt Drive	9040-076-011	1
22	Belt, Driven	9040-073-012	1
23	Thermostat-Overtemp, Reset	9576-207-006	1

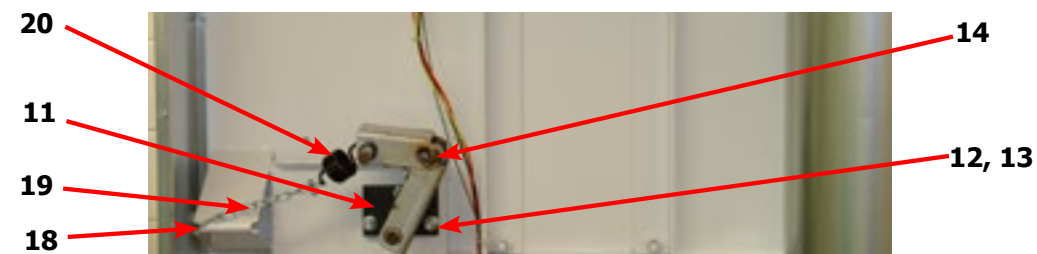

Dryer Rear View 80 Lb

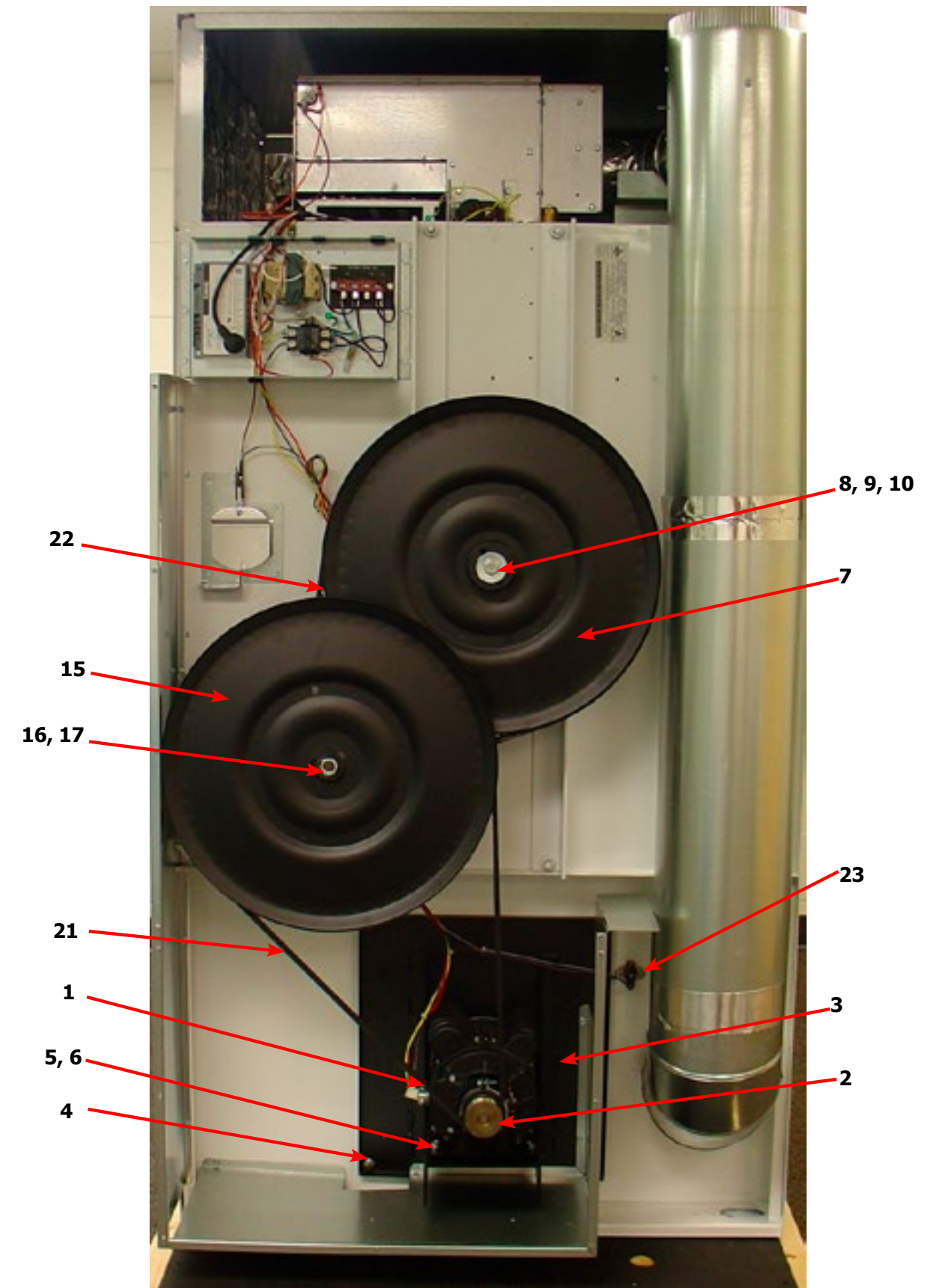

Dryer Rear View-Guard & Exhaust

Key	Description	T-30	T-50	T-80	QTY
1	Cover Cabinet	9074-347-001	9074-348-001	9074-349-001	1
*	Screw-5/16, 10ABx3/8	9545-008-024	9545-008-024	9545-008-024	AR
2	Cover-Control Box	9074-346-001	9074-346-001	9074-346-001	1
3	Screw-5/16, 10ABx3/8	9545-008-024	9545-008-024	9545-008-024	AR
4	Guard, RH	9208-093-001	9208-097-001	9208-101-001	1
*	Screw-5/16, 10ABx3/8	9545-008-024	9545-008-024	9545-008-024	AR
5	Guard Base & LH	9208-094-001	9208-098-001	9208-102-001	1
*	Screw-5/16, 10ABx3/8	9545-008-024	9545-008-024	9545-008-024	AR
6	Guard-Lower	9208-095-001	9208-099-002	9208-103-001	1
7	Screw-5/16, 10ABx3/8	9545-008-024	9545-008-024	9545-008-024	AR
8	Guard-upper	9208-096-001	9208-100-001	9208-104-001	1
*	Screw-5/16, 10ABx3/8	9545-008-024	9545-008-024	9545-008-024	AR
9	Elbow-90 degree, 8"	9042-039-001	9042-039-001	9042-039-001	1
10	Pipe-Duct, 8"	9109-121-001	9109-121-001	9109-121-002	1
11	Tee-Duct, Recirculation, 8"-6"	9810-018-001	9810-018-001	9810-019-001	1
12	Damper	9125-002-001	9125-002-001	9125-008-001	1
*	Pin-Damper, Hinge	9451-146-002	9451-146-002	9451-146-002	1
*	Nut-Spring	8520-141-000	8520-141-000	8520-141-000	2
13	Bracket-Recirculation Duct, Small	9029-228-001	9029-228-001	9028-228-001	1
14	Pipe-Duct, 6"	9109-122-001	9109-122-002	9109-122-003	1
15	Bracket-Duct, Recirculation Large	9029-246-001	9029-247-001	9029-247-001	1
16	Elbow-90 degree, 6"	9142-039-002	9142-039-002	9142-039-002	1
*	Operators Manual	8514-234-001	8514-234-001	8514-234-001	1
17	Diagram & Schematics	9506-546-001	9506-546-001	9506-546-001	1
18	Label-Warning & Notice	8502-763-001	8502-763-001	8502-6763-001	1
19	Label-Instructions	8502-645-001	8502-645-001	8502-645-001	1
20	Decal-Lighting & Clearance	8527-151-001	8527-151-001	8527-151-001	1
21	Label-High Voltage	8502-614-004	8502-614-004	8502-614-004	1
*	8" Slide Open Clean Out Duct	9973-034-001	9973-034-001	9973-034-001	1

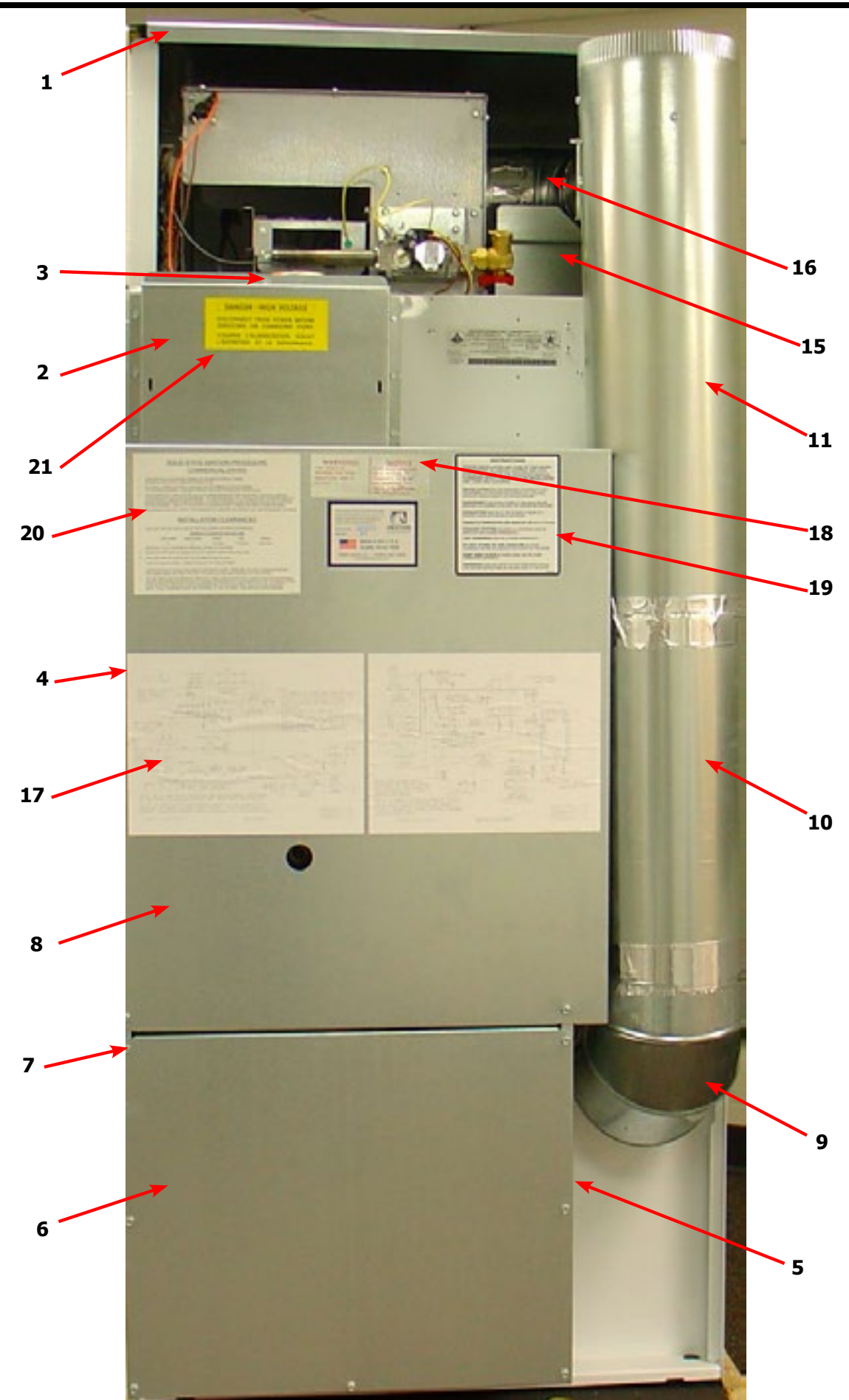
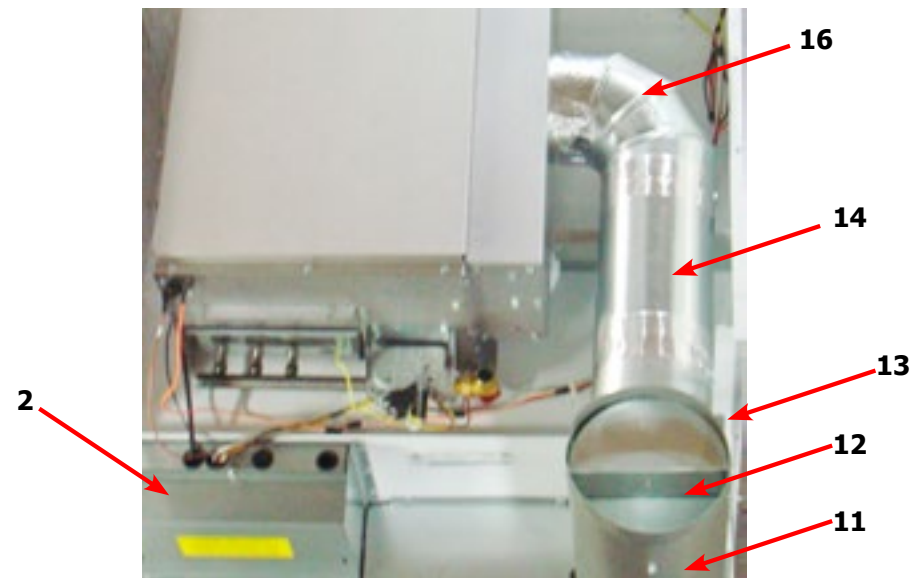

Dryer Rear View-Bearing Housing 30Lb

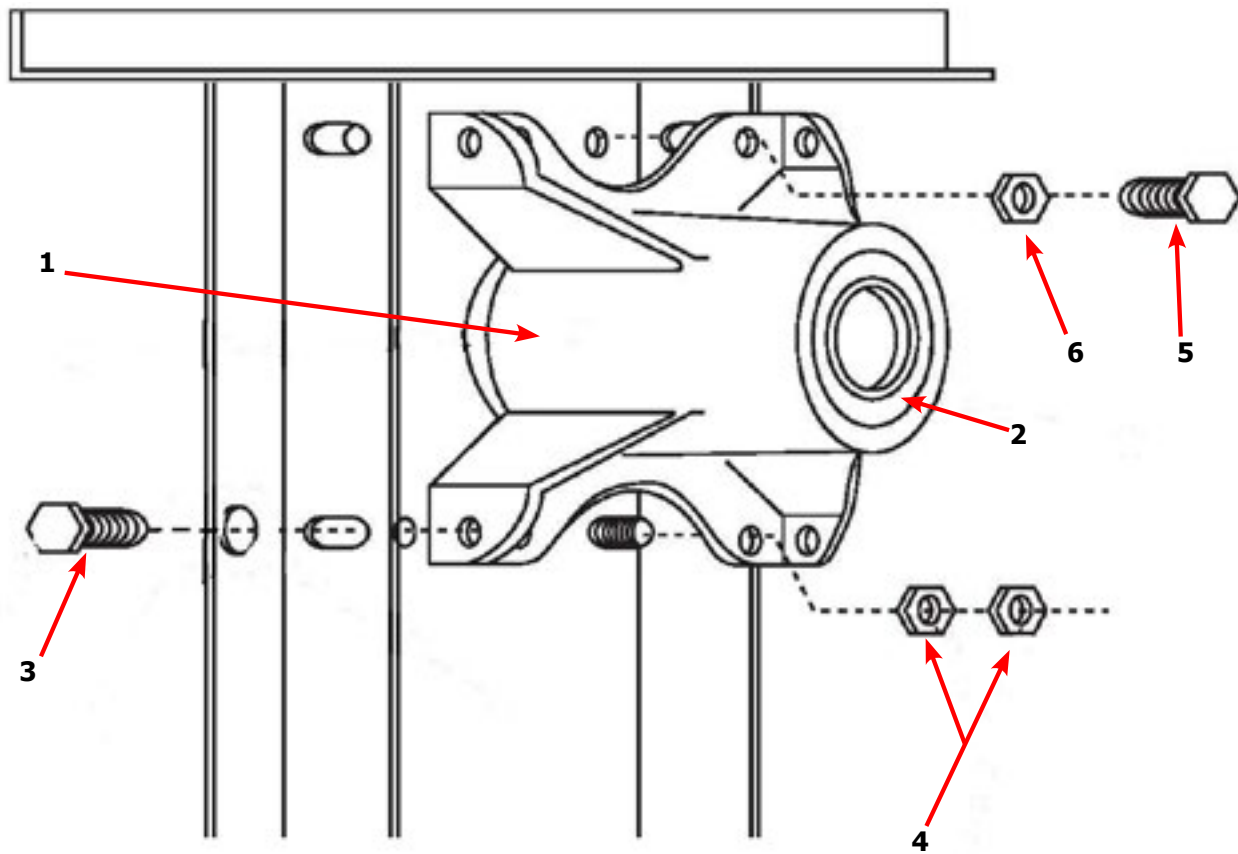

Key	Description	T-30	QTY
*	Bearing Housing Complete Assy. (Includes bearings & Spacer)	9803-160-003	1
1	Housing, Bearing	9241-161-002	1
*	Bearing, Ball, Front	9036-130-001	1
*	Spacer, Bearing	9538-139-002	1
2	Bearing, Ball, Rear	9036-130-001	1
3	Screw-Wizlock, 3/8-24x3/4	9545-049-002	4
4	Nut, 5/16-18	8640-400-002	4
5	Screw, 3/8-24x1	9545-049-001	2
6	Nut, 3/8-24	8640-415-002	2
*	Shim, Tumbler	9538-139-002	AR

↓ Scroll down for
50lb and 80lb
Parts Breakdown

Dryer Tumbler Group 30Lb

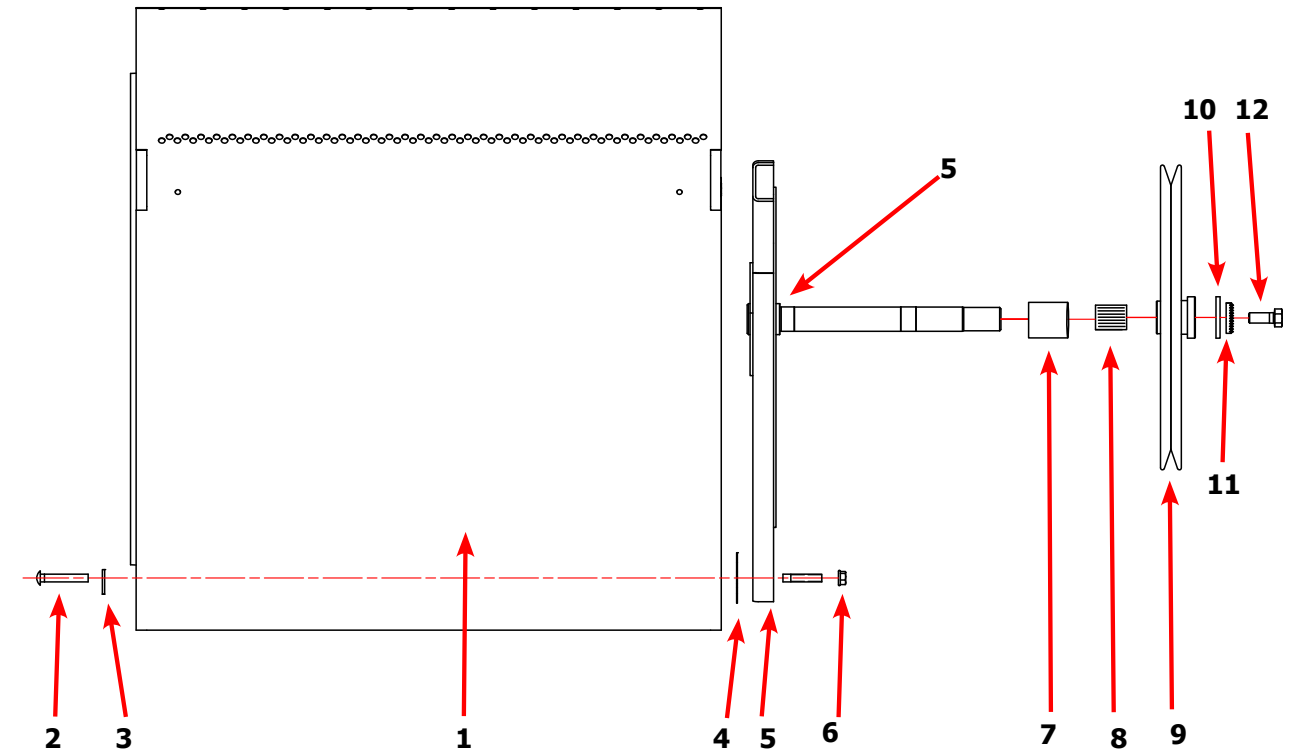

Key	Description	T-30	QTY
*	Tumbler Assy. Complete W/ Spider (GALV)	9848-147-001	1
1	Tumbler Assy. (Galvanized)	9848-146-001	1
*	Tumbler Assy Complete w/ Spider (SS)	9848-147-002	1
*	Tumbler Assy (SS)	9848-146-002	1
2	Rod, Tumbler	9497-226-003	3
3	Washer, Special	8641-554-001	3
4	Shim	9552-013-003	AR
5	Spider Assy.	9568-015-001	1
6	Nut, Wiz Lock	8640-415-004	3
7	Spacer-Shaft	9538-164-001	1
8	Tolerance Ring	9487-234-005	1
9	Pulley, Driven	9908-049-002	1
10	Washer -Flat	8641-581-026	1
11	Lock Washer - IntTooth, 1"	8641-582-016	1
12	Screw, 1/2-13x1 1/4	9545-017-009	1

↓ Scroll down for
50lb and 80lb
Parts Breakdown

Dryer Rear View-Bearing Housing 50Lb

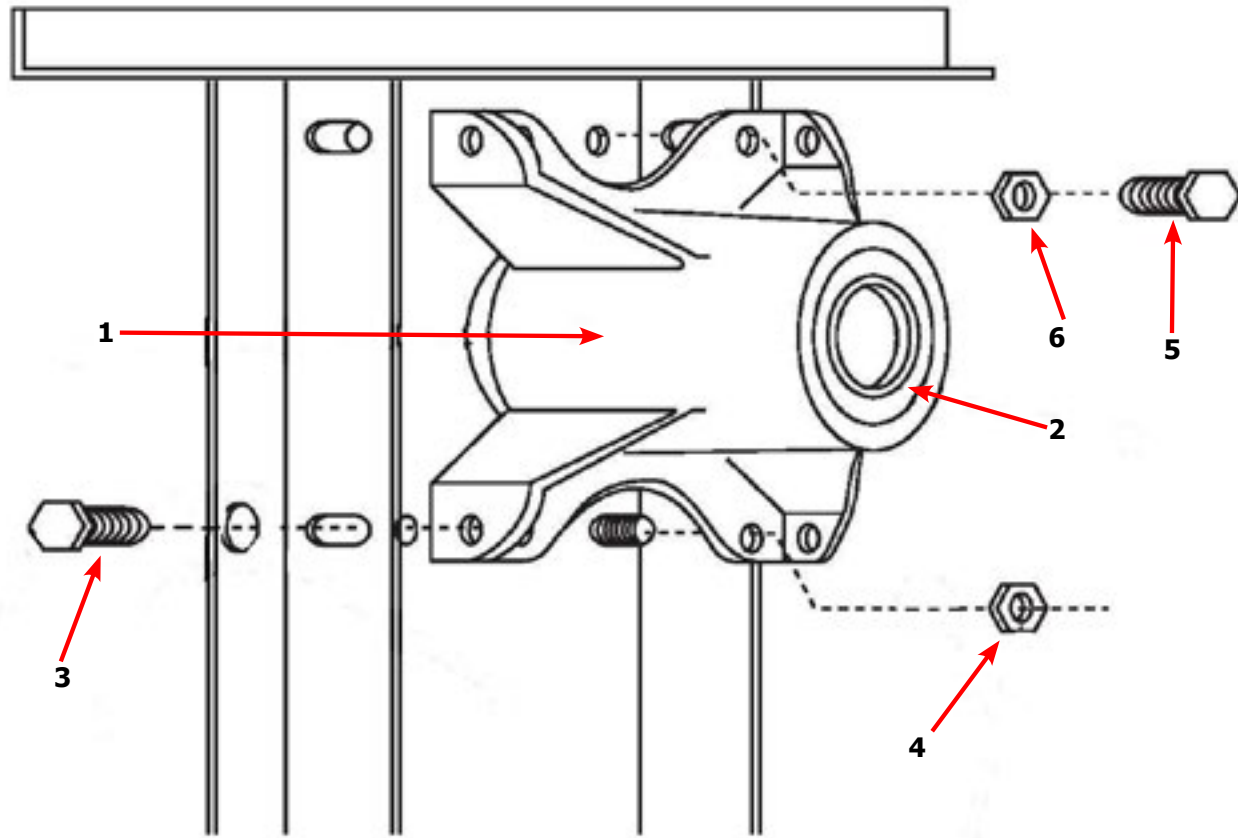

Key	Description	T-50	QTY
	Bearing Housing Complete Assy. (Includes bearings & Spacer)	9803-201-001	1
1	Housing, Bearing	9241-189-002	1
*	Bearing, Ball, Front	9036-159-001	1
*	Spacer, Bearing	9538-183-001	1
2	Bearing, Ball, Rear	9036-159-003	1
3	Screw-Wizlock, 1/2-13x3/4	9545-017-017	4
4	Nut, 1/2-13	8640-417-002	2
5	Screw, 1/2-13x1 1/2	9545-017-018	2
6	Nut, 1/2-13	8640-417-002	2

↓ **Scroll down for
80lb Parts
Breakdown**

Dryer Tumbler Group 50Lb

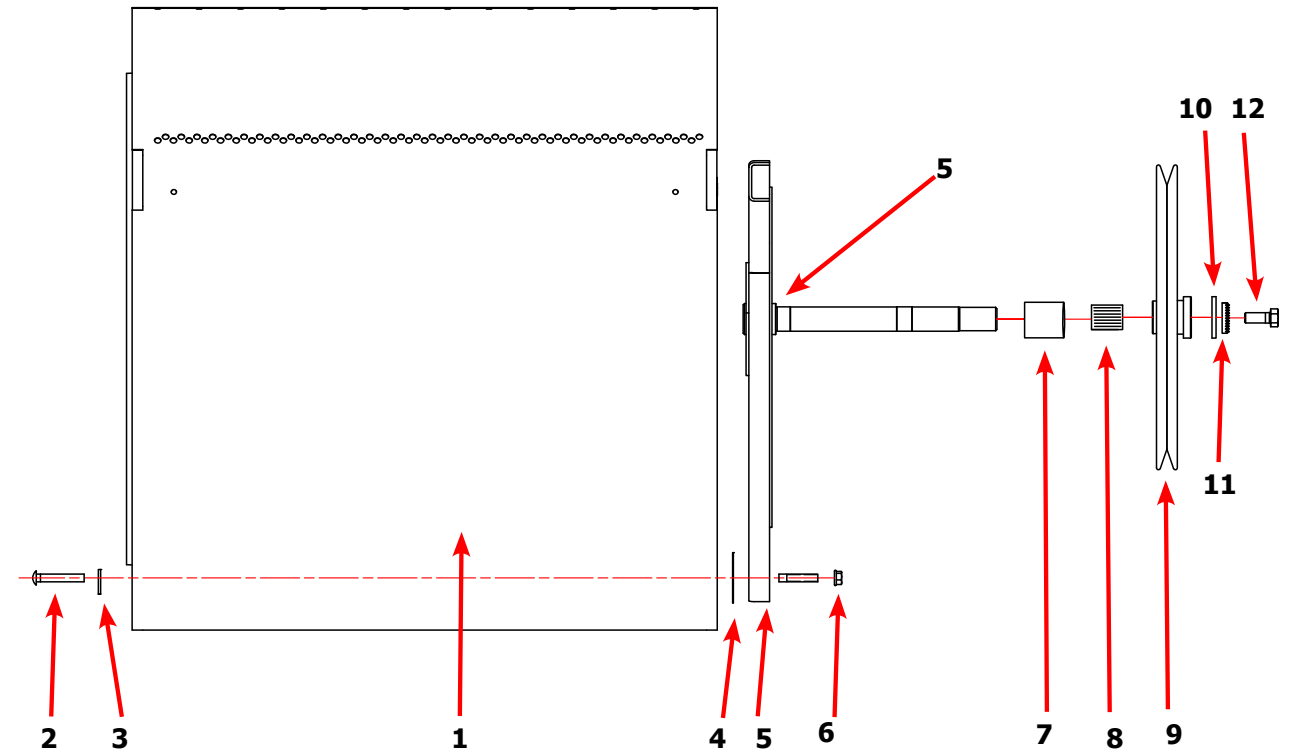

Key	Description	T-50	QTY
*	Tumbler Assy. Complete W/ Spider (GALV)	9848-149-001	1
1	Tumbler Assy. (Galvanized)	9848-148-001	1
*	Tumbler Assy. Complete W/ Spider (SS & Galv front)	9848-149-002	1
1	Tumbler Assy. (Stainless Galvanized front)	9848-148-002	1
2	Rod, Tumbler	9497-226-002	3
3	Washer, Special	8641-590-002	3
4	Shim	9552-013-000	AR
5	Spider Assy.	9568-013-001	1
6	Nut, Wiz Lock	8640-417-005	3
7	Spacer-Shaft	9538-184-001	1
8	Tolerance Ring	9487-234-005	1
9	Pulley, Driven	9908-047-002	1
10	Washer -Flat	8641-581-026	1
11	LockWasher - IntTooth, 1"	8641-582-016	1
12	Screw, 1/2-13x1 1/4	9545-017-009	1

↓ **Scroll down for
80lb Parts
Breakdown**

Dryer Rear View-Bearing Housing 80Lb

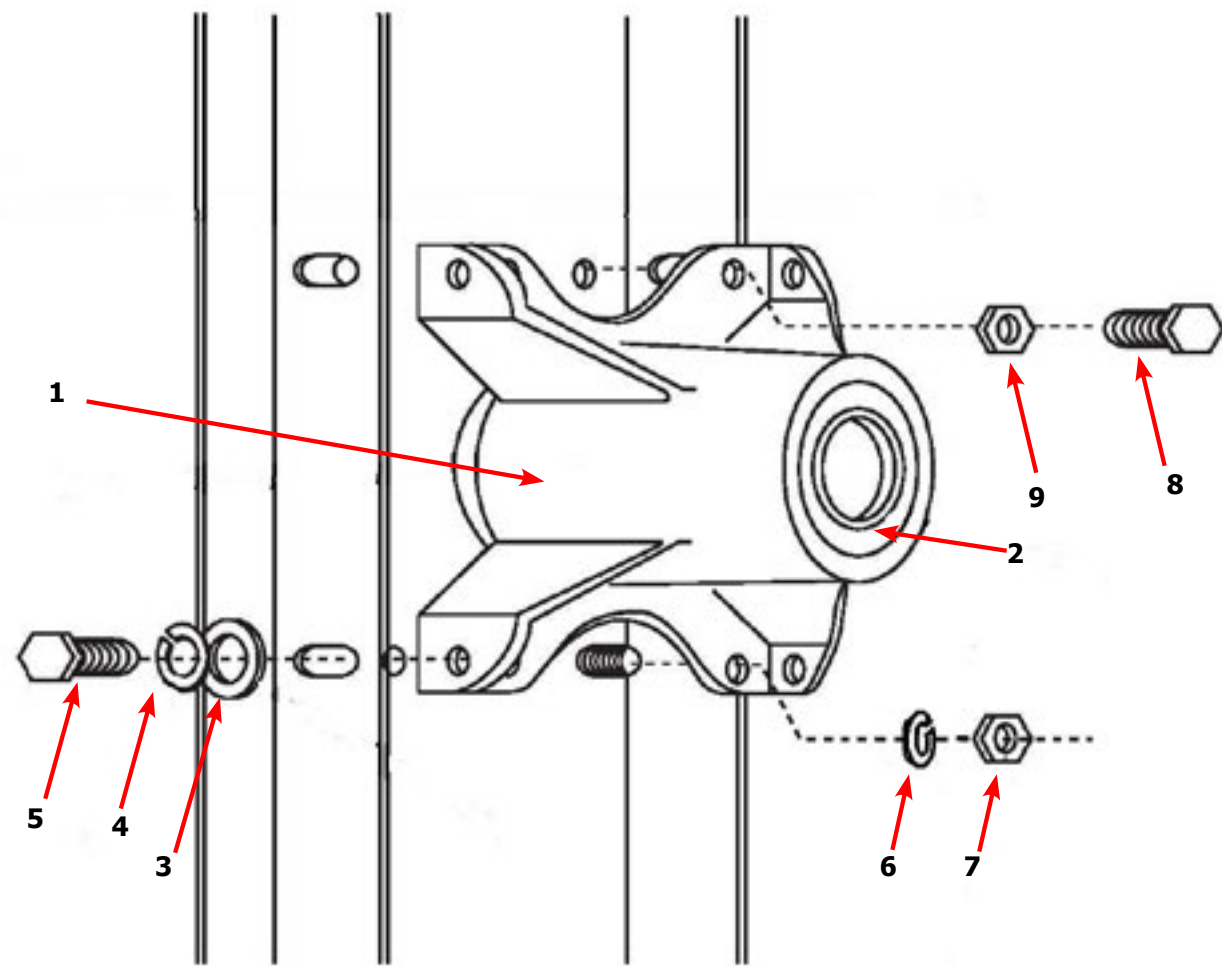

Key	Description	T-80	QTY
	Bearing Housing Complete Assy. (Includes bearings & Spacer)	9803-189-001	
1	Housing, Bearing	9241-183-003	
*	Bearing, Ball, Front	9036-159-002	
*	Spacer, Bearing		
2	Bearing, Ball, Rear	9036-159-001	
3	Washer, Flat 1/2	8641-581-026	
4	Lock Washer Spring, 1/2	8641-582-004	
5	Screw, 1/2-13x1	9545-017-004	
6	Lock Washer Spring, 1/2	8641-582-004	
7	Nut, 7/16-14	8640-416-001	
8	Screw, 7/16-14x1 1/2	9545-059-003	
9	Nut, 7/16-14	8641-416-001	

Dryer Tumbler Group 80Lb

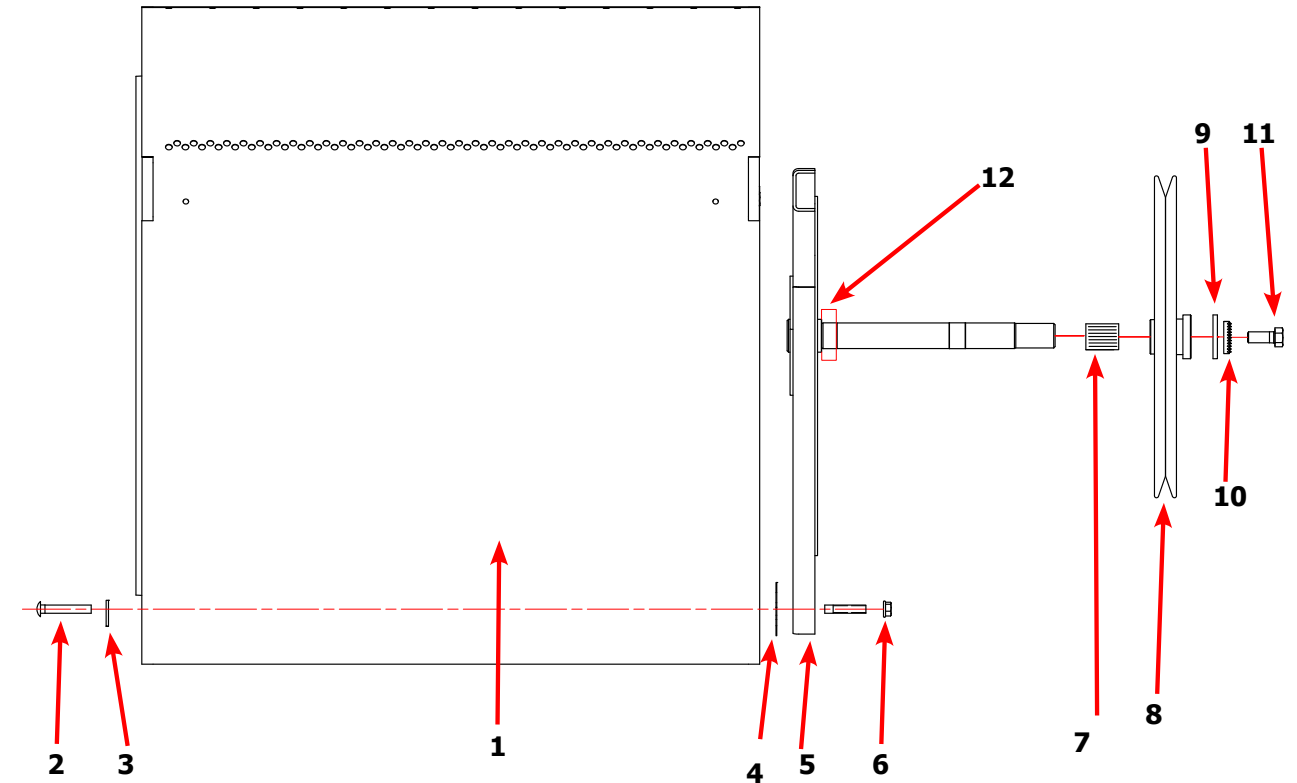

Key	Description	T-80	QTY
*	Tumbler Assy. Complete W/ Spider (GALV)	9848-151-001	1
1	Tumbler Assy. (Galvanized)	9848-150-001	1
1	Tumbler Assy. Complete W/ Spider (SS & Galv front)	9848-151-002	1
1	Tumbler Assy. (Stainless Galvanized front)	9848-150-002	1
2	Rod, Tumbler	9497-266-001	4
3	Washer, Special	8641-590-001	4
4	Shim	9552-013-000	AR
5	Spider Assy. w/ Front Bearing	9873-008-001	1
6	Nut, Wiz Lock	8640-417-005	4
7	Tolerance Ring	9487-234-001	1
8	Pulley, Driven	9908-043-002	1
9	Washer -Flat	8641-581-026	1
10	LockWasher - IntTooth, 1"	8641-582-016	1
11	Screw, 1/2-13x1 1/4	9545-017-009	1
12	Bearing, Front	9036-159-002	1

Dryer Burner Housing Group 30Lb

Key	Description	Part Number	Qty
*	Housing Assembly, Burner	9803-210-001	1
1	Panel-Burner Housing, Side Left	9454-845-001	1
2	Baffle-Burner Housing, Center	9049-091-001	1
3	Panel-Burner Housing, Top	9454-871-001	1
4	Panel-Burner Housing, Front	9454-847-001	1
5	Panel-Burner Housing, Back	9454-848-001	1
6	Baffle-Burner Housing, Recirculation	9049-092-001	1
7	Baffle-Burner Housing, Front	9049-093-001	1
8	Duct Adaptor, 6"x 3" long	9109-120-01	1
9	Burner, Main	9048-021-001	2
10	Bracket-Support, Electrode	9029-214-001	1
11	Bracket-Support, Gas Valve	9029-227-001	1
12	Electrode-Ignition	9875-002-003	1
13	Control Assy, Gas Valve, White Rodgers 36J	9857-192-001	1
14	Manifold Assy.	9381-009-007	1
15	Valve-Gas Shutoff (Optional)	9379-196-001	1
16	Thermostat-HI-Limit	9576-203-002	1
17	Screw, 10ABx3/8	9545-008-024	24
18	Screw, 10ABx1/4	9545-008-006	17
19	Orifice-Natural, .125	9425-069-023	2
*	Orifice-LP, #48	9425-069-003	2
*	Kit, LP Conversion, White Rodgers	9732-102-018	1
20	Bracket-Support, Burner	9029-225-001	1
21	Panel-Burner Housing, Side Right	9454-861-001	1
22	Screw, 10-32TTx1/2 Green	9545-008-027	3
23	Screw, 8-32x3/8	9545-010-014	4

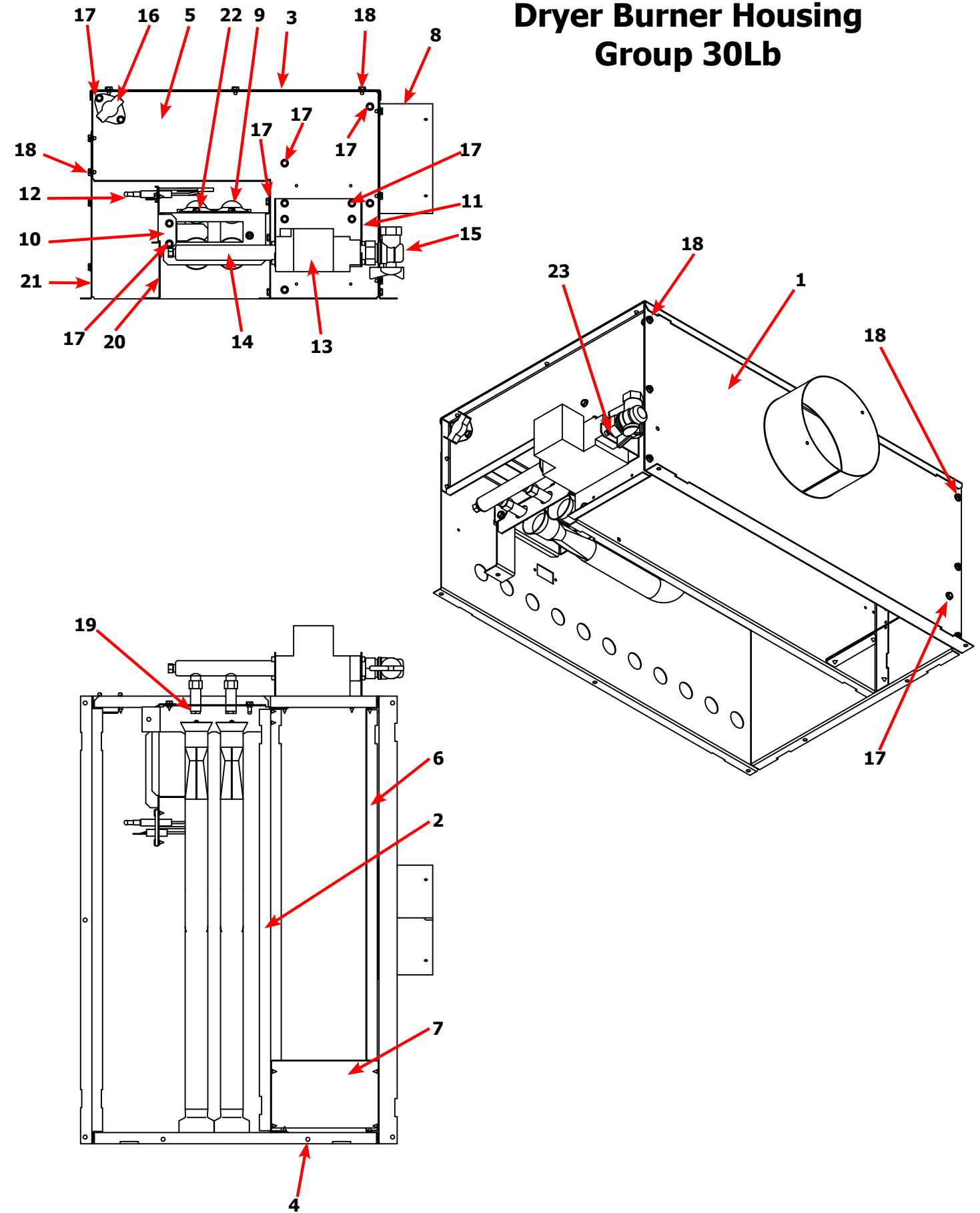

↓ Scroll down for
50lb and 80lb
Parts Breakdown

Dryer Burner Housing Group 50Lb

Key	Description	Part Number	Qty
	Housing Assembly, Burner	9803-211-001	1
1	Panel-Burner Housing, Front	9454-863-001	1
2	Panel-Burner Housing, Side Right	9454-861-001	1
3	Panel-Burner Housing, Side Left	9454-862-001	1
4	Panel-Burner Housing, Back	9454-864-001	1
5	Baffle-Burner Housing, Center	9049-098-001	1
6	Panel-Burner Housing, Top	9454-849-001	1
7	Panel-Burner Housing, Top	9074-343-001	1
8	Baffle-Burner Housing, Extension	9049-100-001	1
9	Duct Adaptor, 6"x1.25" long	9109-120-003	1
10	Baffle-Burner Housing, Recirculation	9049-099-001	1
11	Side-Extension Baffle, Burner Housing	9551-049-001	2
12	Bracket-Support, Burner	9029-213-001	1
13	Burner, Main	9048-021-001	3
14	Screw, 10T-32x1/2	9545-008-008	3
15	Electrode-Ignition	9875-002-003	1
16	Cover-Burner, Inlet	9074-344-001	1
17	Bracket-Support, Gas Valve	9029-227-001	1
18	Control Assy, Gas Valve, White Rodgers 36J	9857-192-001	1
19	Screw, #8-32x3/8	9545-010-014	4
20	Valve-Gas Shutoff, (Optional)	9379-196-001	1
21	Manifold Assy.	9381-010-003	1
*	Orifice-Natural, #30	9425-069-002	3
*	Orifice-LP, #48	9425-069-003	3
*	Kit, LP Conversion, White Rodgers	9732-102-017	1
23	Thermostat-HI-Limit	9576-203-002	1
24	Spacer-1/4x5/8 long	9538-166-009	2
25	Screw-8Bx1	9545-045-013	2
26	Screw, 10Bx1/4	9545-008-001	22
27	Screw, 10ABx3/8	9545-008-024	31

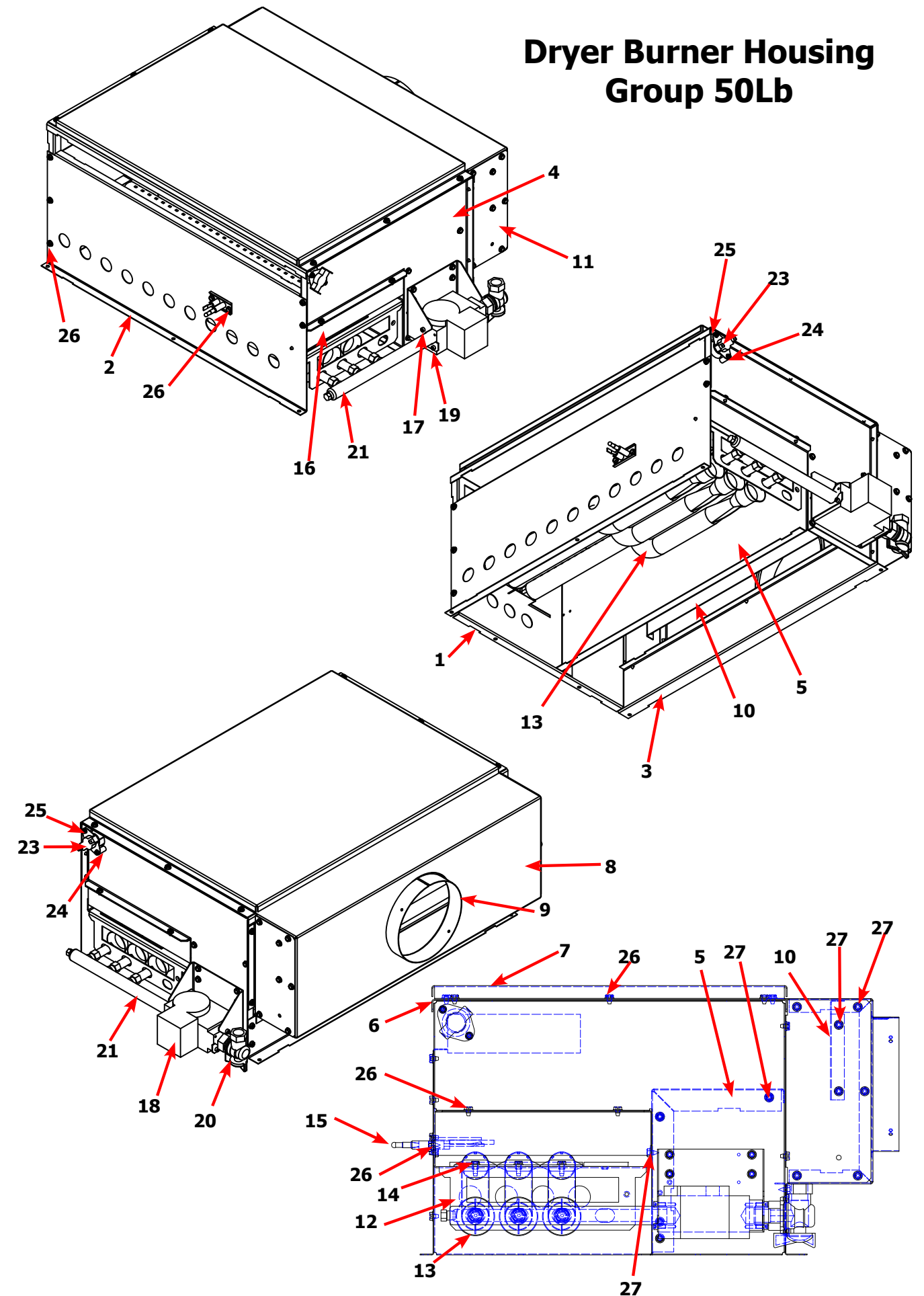



**Scroll down for
80lb Parts
Breakdown**

Dryer Burner Housing Group 80Lb

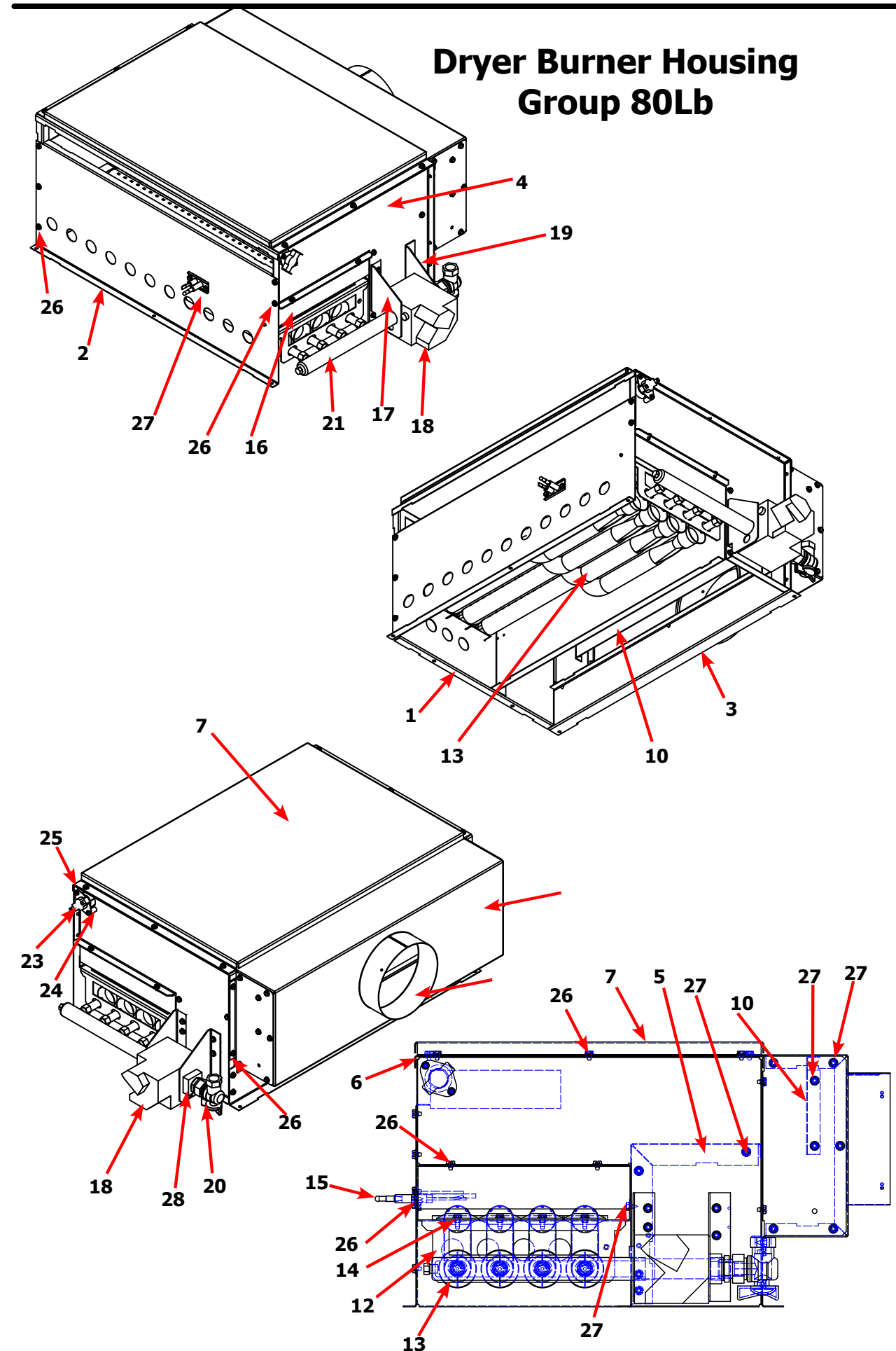
Key	Description	Part Number	Qty
	Housing Assembly, Burner	9803-212-001	1
1	Panel-Burner Housing, Front	9454-863-001	1
2	Panel-Burner Housing, Side Right	9454-861-001	1
3	Panel-Burner Housing, Side Left	9454-862-001	1
4	Panel-Burner Housing, Back	9454-864-001	1
5	Baffle-Burner Housing, Center	9049-098-001	1
6	Panel-Burner Housing, Top	9454-849-001	1
7	Panel-Burner Housing, Top	9074-343-001	1
8	Baffle-Burner Housing, Extension	9049-100-001	1
9	Duct Adaptor, 6"x1.25" long	9109-120-002	1
10	Baffle-Burner Housing, Recirculation	9049-099-001	1
11	Side-Extension Baffle, Burner Housing	9551-049-001	2
12	Bracket-Support, Burner	9029-213-001	1
13	Burner, Main	9048-021-001	4
14	Screw, 10T-32x1/2	9545-008-008	4
15	Electrode-Ignition	9875-002-003	1
16	Cover-Burner, Inlet	9074-344-001	1
17	Bracket-Support, Gas Valve	9029-234-001	1
18	Control Assy. Gas Valve, White Rodgers 36J	9857-193-001	1
19	Bracket-support, Gas Valve Left hand	9029-235-001	4
20	Valve-Gas Shutoff, (Optional)	9379-196-001	1
21	Manifold Assy.	9381-014-001	1
22	Orifice-Natural, #29	9425-069-021	3
*	Orifice-LP, #46	9425-069-022	3
*	Kit, LP Conversion, White Rodgers	9732-102-023	1
23	Thermostat-HI-Limit	9576-203-002	1
24	Spacer-1/4x5/8 long	9538-166-009	2
25	Screw-8Bx1	9545-045-013	2
26	Screw, 10Bx1/4	9545-008-001	22
27	Screw, 10ABx3/8	9545-008-024	31
28	Bushing-Reducer, 3/4x1/2	8615-104-009	1

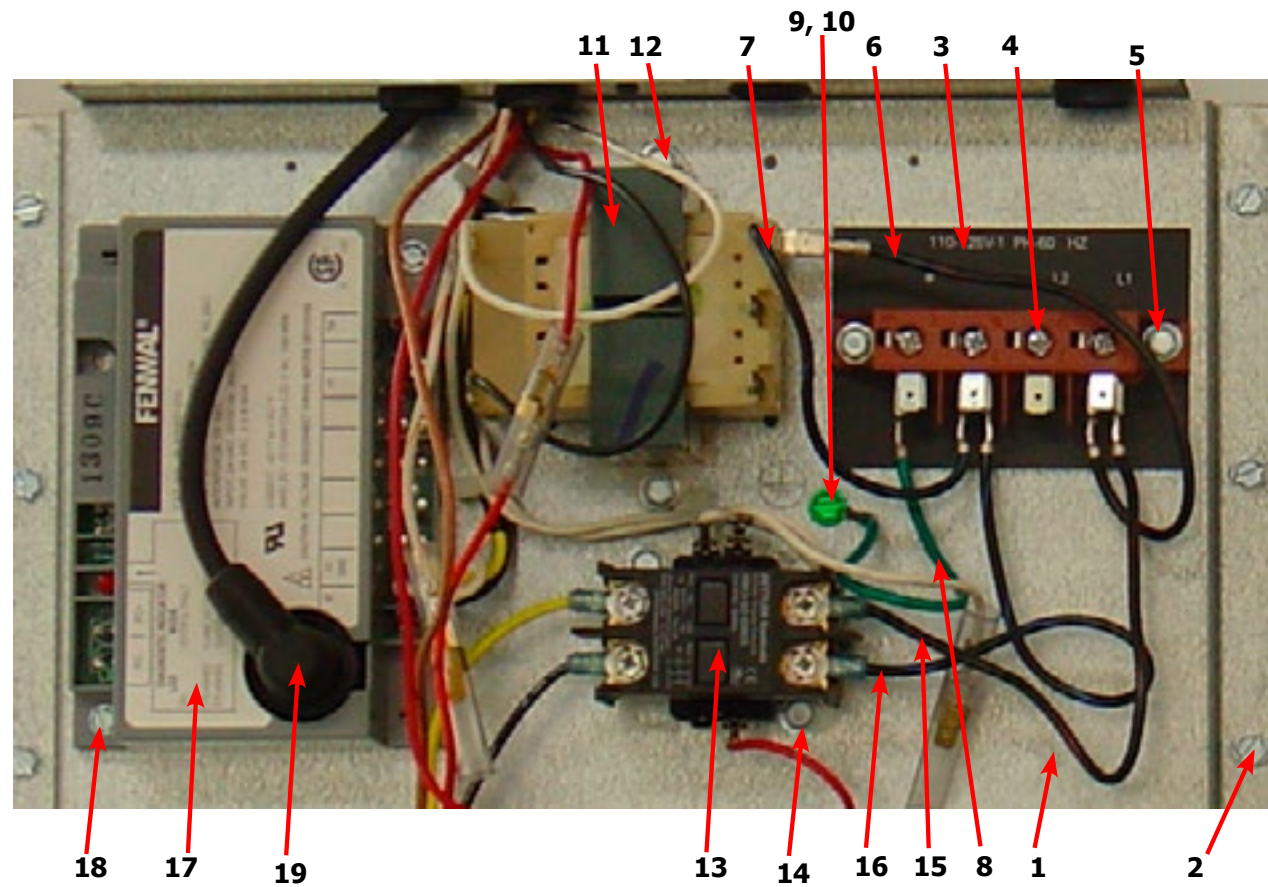

Electrical Box / Ignition Control



Key	Description	T-30	T-50	T-80	QTY
1	Wrapper-Control Box	9636-200-001	9636-200-001	9636-200-001	1
2	Screw, 5/16-10AB-3/8	9545-008-001	9545-008-001	9545-008-001	6
*	Cover-Control Box	9074-346-001	9074-346-001	9074-346-001	1
*	Screw, 5/16-10AB-3/8	9545-008-024	9545-008-024	9545-008-024	1
3	Strip-Marker, Terminal	9558-029-005	9558-029-005	9558-029-005	1
4	Terminal Block Assy-Power, 4Pole	9897-035-001	9897-035-001	9897-035-001	1
5	Screw, 5/16-10AB-3/8	9545-008-024	9545-008-024	9545-008-024	2
6	Wire assy-Blk/Red, 6 1/2"	8220-001-230	8220-001-230	8220-001-230	1
7	Wire assy-Blk/Blu, 6 1/2"	8220-001-231	8220-001-231	8220-001-231	1
8	Wire Assy, GRN, 7"	8220-001-478	8220-001-478	8220-001-478	1
9	Screw- 10-32TTx1/2 GRN	9545-008-027	9545-008-027	9545-008-027	1
10	Lockwasher, External tooth	8641-582-006	8641-582-006	8641-582-006	1
11	Transformer, w/Circuit breaker	8711-007-002	8711-007-002	8711-007-002	1
12	Screw, 5/16-10AB-3/8	9545-008-024	9545-008-024	9545-008-024	2
13	Relay-Motor, 30Amp, 24VAC	5192-299-002	5192-299-002	5192-299-002	1
14	Screw, 5/16-10AB-3/8	9545-008-024	9545-008-024	9545-008-024	2
15	Wire assy-Blk/Red, 9"	8220-146-001	8220-146-001	8220-146-001	1
16	Wire assy-Blk/Blu, 9"	8220-146-002	8220-146-002	8220-146-002	1
17	Control Assy, Ignition (Module)	9857-182-001	9857-182-001	9857-182-001	1
18	Screw-8Bx3/4"	9545-045-007	9545-045-007	9545-045-007	2
*	Harness, Ignition Module	9627-867-003	9627-867-003	9627-867-003	1
19	Wire Assy- High Voltage Lead	9631-403-009	9631-403-009	9631-403-009	1

Airflow Switch Assembly

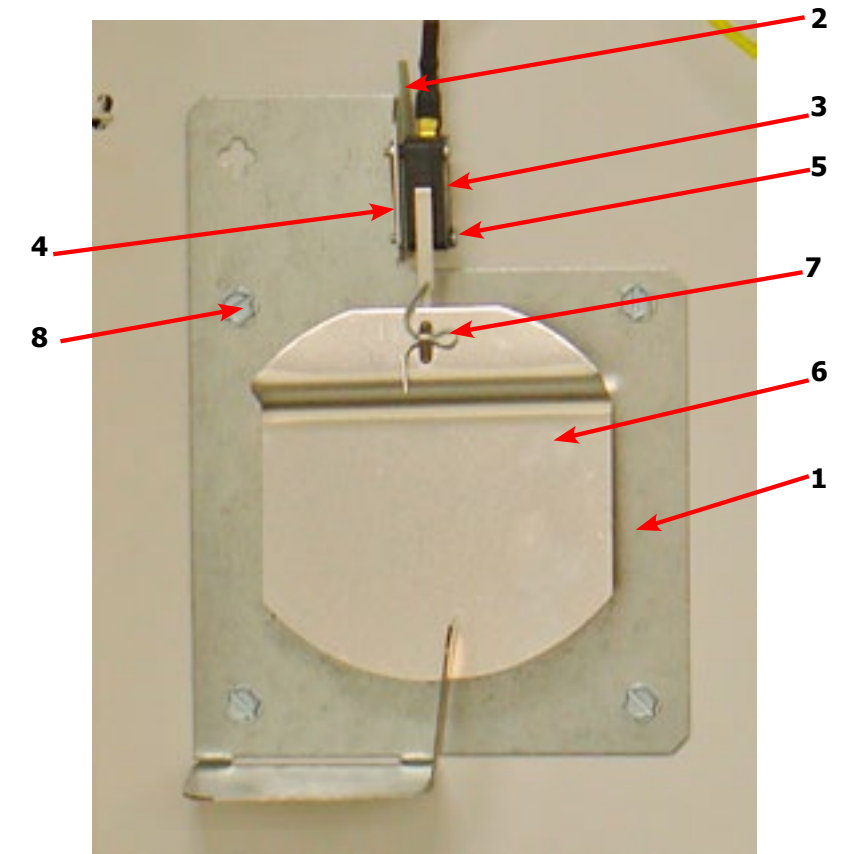

Key	Description	T-30	T-50	T-80	QTY
*	Air Flow switch Assy.	9801-095-001	9801-098-001	9801-098-001	1
1	Bracket-Airflow switch	9029-174-001	9029-200-001	9029-200-001	1
2	Shield-Switch	9550-169-003	9550-169-003	9550-169-003	1
3	Switch-Micro	9539-461-009	9539-461-009	9539-461-009	1
4	Nut-Twin, 4-40	8640-401-001	8640-401-001	8640-401-001	1
5	Screw-.625, 4-40	9545-020-001	9545-020-001	9545-020-001	2
6	Actuator-Air Flow Switch	9008-007-001	9008-007-001	9008-007-001	1
7	Pin-Cotter, .09375x.75	9451-169-002	9451-169-002	9451-169-002	1
	Screw, 10Bx1/4	9545-008-001			3
	Screw, 10Bx1/4		9545-008-001	9545-008-001	4

Wiring Schematic for 60hz Dryer -10

9506-546-001PR

SCHEMATIC

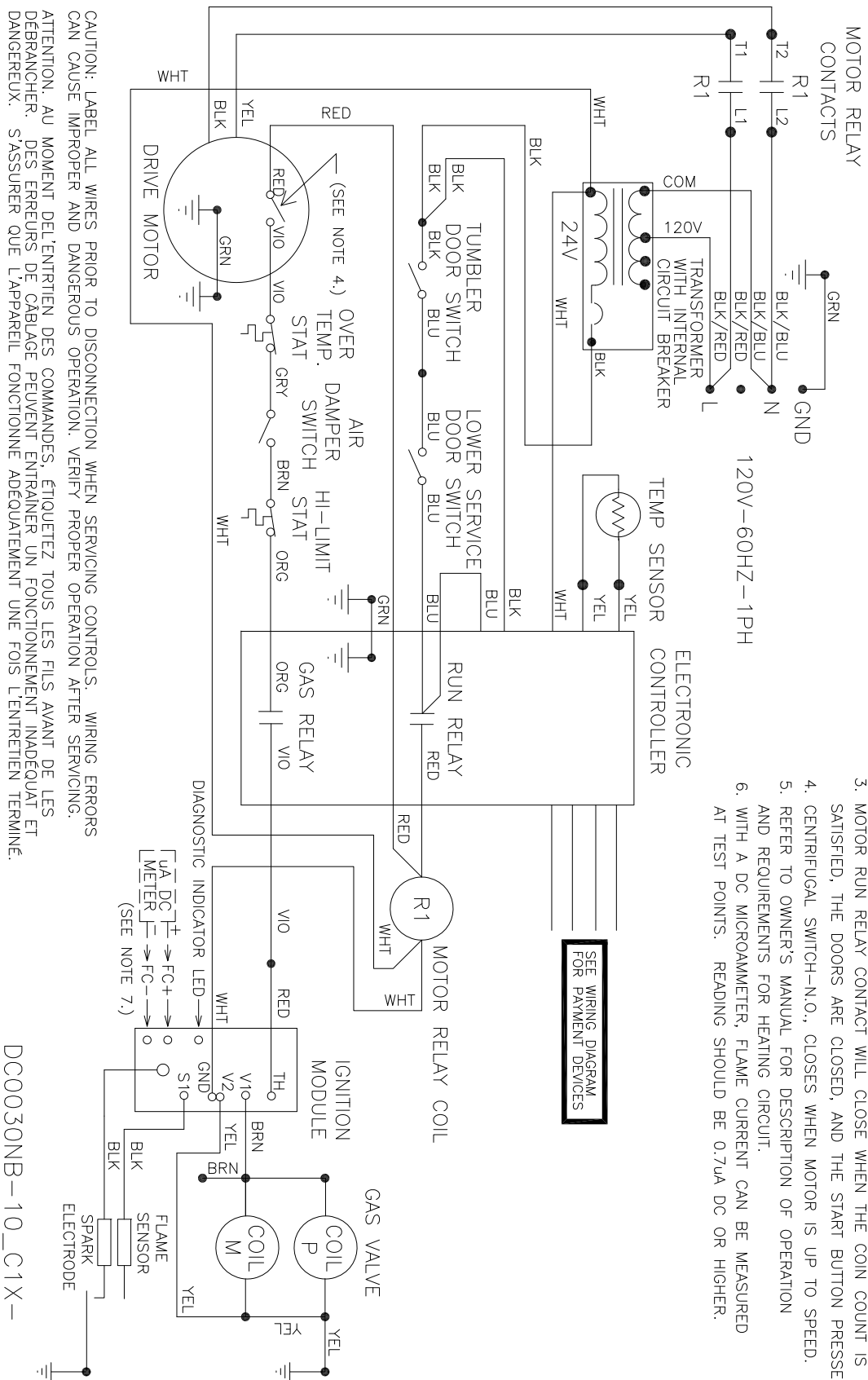

CAUTION: LABEL ALL WIRES PRIOR TO DISCONNECTION WHEN SERVICING CONTROLS. WIRING ERRORS CAN CAUSE IMPROPER AND DANGEROUS OPERATION. VERIFY PROPER OPERATION AFTER SERVICING.
ATTENTION: AU MOMENT DE L'ENTRIEN DES COMMANDES, ÉTIQUETEZ TOUTS LES FILS AVANT DE LES DÉBRANCHER. DES ERREURS DE CÂBLAGE PEUVENT ENTRAÎNER UN FONCTIONNEMENT INADÉQUAT ET DANGEREUX. S'ASSURER QUE L'APPAREIL FONCTIONNE ADEQUATEMENT UNE FOIS L'ENTRIEN TERMINÉ.

- NOTES:
1. COIN SWITCH-N.O., CLOSES WHEN COIN IS INSERTED (SEE SHEET 2).
 2. DOOR SWITCHES-N.O., CLOSED WHEN DOORS ARE CLOSED.
 3. MOTOR RUN RELAY CONTACT WILL CLOSE WHEN THE COIN COUNT IS SATISFIED, THE DOORS ARE CLOSED, AND THE START BUTTON PRESSED.
 4. CENTRIFUGAL SWITCH-N.O., CLOSES WHEN MOTOR IS UP TO SPEED.
 5. REFER TO OWNER'S MANUAL FOR DESCRIPTION OF OPERATION AND REQUIREMENTS FOR HEATING CIRCUIT.
 6. WITH A DC MICROAMMETER, FLAME CURRENT CAN BE MEASURED AT TEST POINTS. READING SHOULD BE 0.7uA DC OR HIGHER.

SEE WIRING DIAGRAM FOR PAYMENT DEVICES

Wiring Diagram for 60hz Dryer -10

9506-546-001PR

WIRING DIAGRAM

DC0030NB-10_C1X-
DC0050NB-10_C1X-
DC0080NB-10_C1X-

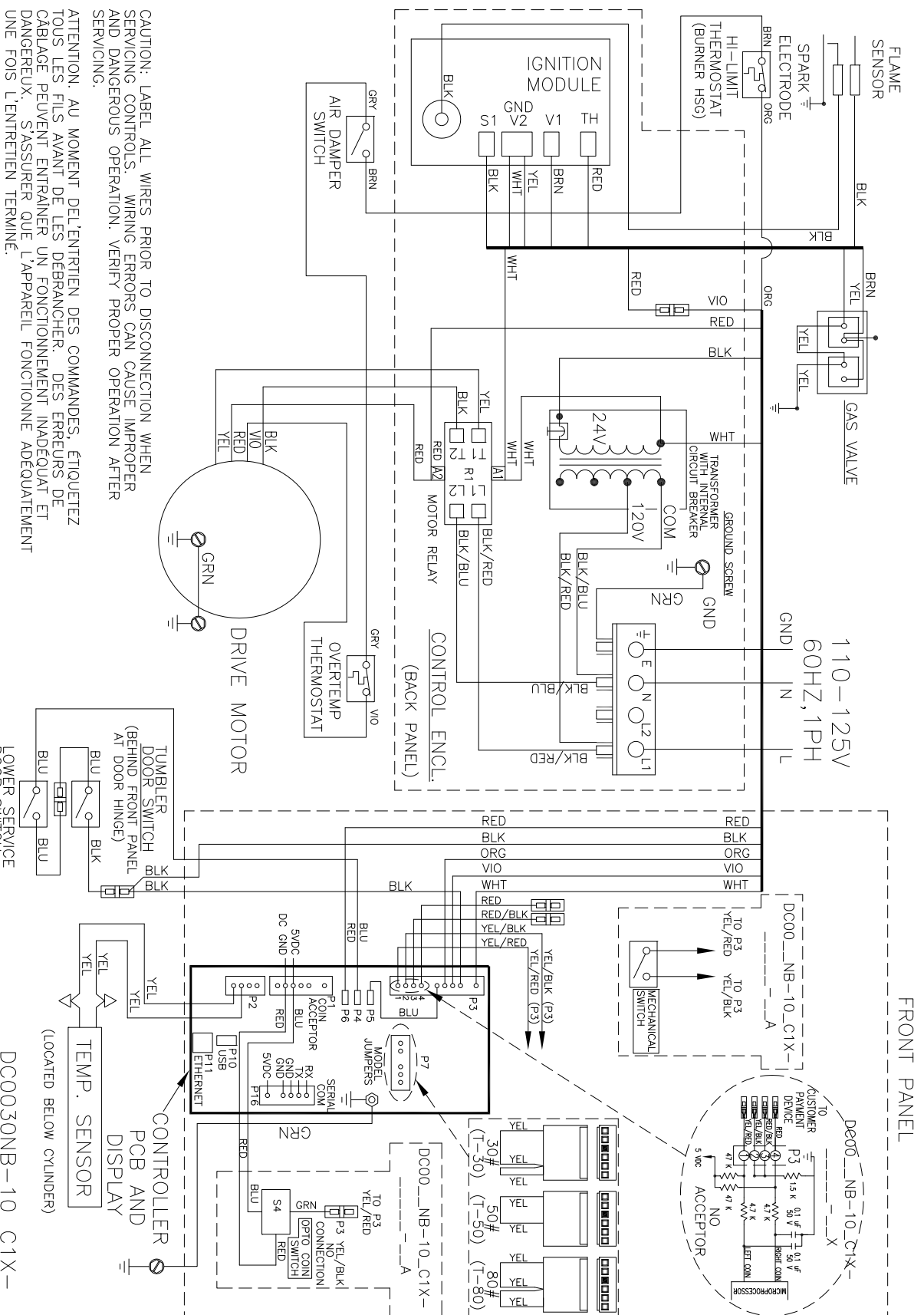

CAUTION: LABEL ALL WIRES PRIOR TO DISCONNECTION WHEN SERVICING CONTROLS. WIRING ERRORS CAN CAUSE IMPROPER AND DANGEROUS OPERATION. VERIFY PROPER OPERATION AFTER SERVICING.
ATTENTION: AU MOMENT DE L'ENTRIEN DES COMMANDES, ÉTIQUETEZ TOUTS LES FILS AVANT DE LES DÉBRANCHER. DES ERREURS DE CÂBLAGE PEUVENT ENTRAÎNER UN FONCTIONNEMENT INADÉQUAT ET DANGEREUX. S'ASSURER QUE L'APPAREIL FONCTIONNE ADEQUATEMENT UNE FOIS L'ENTRIEN TERMINÉ.

WIRING DIAGRAM (BEHIND LOWER SERVICE PANEL)

TEMP. SENSOR (LOCATED BELOW CYLINDER)

30 lb. Commercial Dryer: T-30 – DC0030NB-10EC1X (60 Hz), DC0030NB-39AC1X (50 Hz)

Cabinet Height	72 1/4"	1835 mm.
(Assumes minimum leveling leg adjustment)		
Cabinet Width	31 1/2"	800 mm.
Overall Depth	42"	1067 mm.
Floor to Door Center	41 1/4"	1048 mm.
Door Opening	22 5/8"	575 mm.
Dry Wt. Capacity	30 lbs.	13.6 kg.
Cylinder Diameter	30"	762 mm.
Cylinder Depth	27 1/2"	699 mm.
Cylinder Volume	11.25 cu. ft.	319 liters
Lint Screen Area	515 sq. in.	3323 sq. cm.
Gas Input (60 hz)	90,000 Btu/hr	26.4 kW
Gas Input (50 hz)	72,000 Btu/hr	21.1 kW
Gas Supply Connection	1/2"	12.7 mm.
Natural Gas Supply (Water Column)	5-10"	127 mm. - 254 mm.
Natural Burner Manifold	3 1/2"	88.9 mm.
L.P. Supply (Water Column)	11 1/2 -14"	292 mm. - 356 mm.
L.P. Burner Manifold	11"	279 mm.
Exhaust Size	8"	203 mm.
Make-up Air	1.0 sq. ft.	929 sq. cm.
Example: 1.0 sq. ft = 1 ft. long X 1 ft. wide		
Motor Size	1/2 H.P.	.373 kW
Airflow (60 hz)	830 CFM	23.5 m ³ /min
Airflow (50 hz)	690 CFM	19.5 m ³ /min

Electrical Specifications - 220-240/50/1

Voltage/Hz/Phase	220-240V/50Hz/1Phase	
Running Amps	5.1	
Circuit Protection Amps	10	
Wire Size	14 gauge	
Electrical Service	2 wire + ground	

Shipping Weight	507 lbs.	231 kg.
Net Weight	463 lbs. 210 kg.	
Clearance Behind Machines (min.)	18"	457 mm.

Parts Section-39 & -59 230VAC 1 PH 50Hz

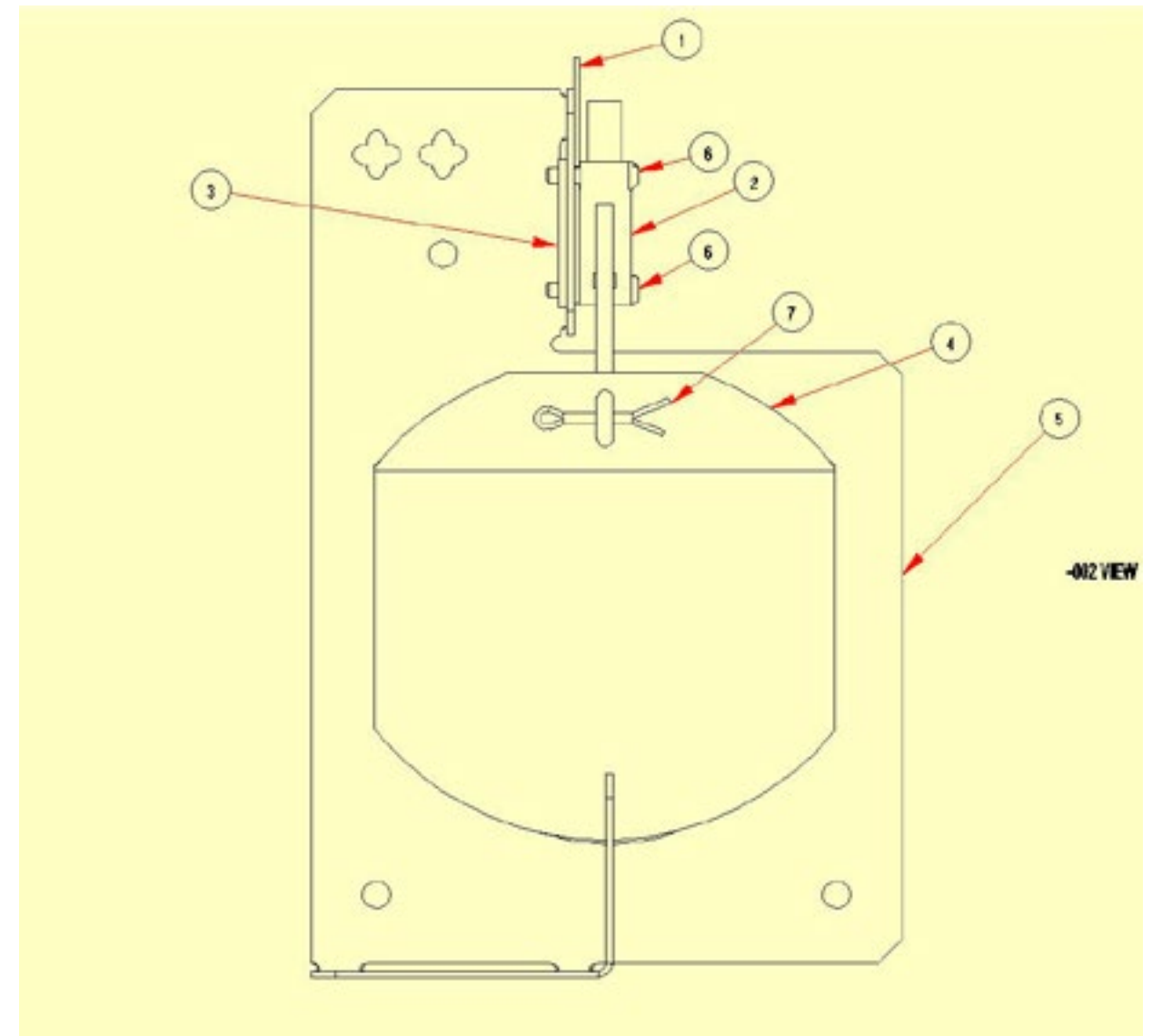

Key	Description	T-30	T-50	T80	QTY
	Switch Assembly-Air flow (1-7)	9801-095-002	9801-098-002	9801-098-002	1
1	Shield - Switch	9550-169-003	9550-169-003	9550-169-003	1
2	Switch Micro	9539-461-009	9539-461-009	9539-461-009	1
3	Nut - Twin, 4-40	8640-401-001	8640-401-001	8640-401-001	1
4	Actuator-Switch, Air-Flow	9008-007-001	9008-007-001	9008-007-001	1
5	Bracket-Airflow switch	9029-174-002	9029-200-002	9029-200-002	1
6	Screw-PNHDSL, 4-40, UNC x 0.625	9545-020-001	9545-020-001	9545-020-001	2
7	Pin-Cotter, 0.09375 x 0.75	9451-169-002	9451-169-002	9451-169-002	1

Parts for 50hz Dryer -39

Key	Description	T-30	T-50	T80	QTY
*	Motor, Marathon 50Hz	9376-311-004	9376-317-004	9376-317-004	1
*	Pulley, Motor	9453-169-009	9453-169-014	9435-169-009	1
*	Strip Terminal Marker	9558-029-004	9558-029-004	9558-029-004	1
*	Wiring Label-Schematic/Diagram	9506-496-001	9506-496-001	9506-496-001	1
*	Orifice Main Burner, #32 Natural	9425-069-009	N.A.	N.A	2
*	Orifice Main Burner, #32 Natural	N.A.	9425-069-009	N.A	3
*	Orifice Main Burner, #30 Natural	N.A.	N.A.	9425-069-002	4
*	LP Kit	9732-102-019	9732-102-021	9732-102-022	1
*	Overlay-Trim Lower door	9435-016-004	9435-016-005	9435-016-006	1
*	Label Warning	8502-698-001	8502-698-001	8502-698-001	1

Parts for 50hz Dryer -59

Key	Description	T-30	T-50	T80	QTY
*	Strip Terminal Marker	9558-029-004	9558-029-004	9558-029-004	1
*	Filter, EMI Line	9183-030-001	9183-030-001	9183-030-001	1
*	Transformer, Control (Before Serial)	8711-008-002	8711-008-002	8711-008-002	1
*	Transformer (After Serial)	8711-004-004	8711-004-004	8711-004-004	1
*	Holder, Fuse	9054-045-001	9045-045-001	9045-045-001	1
*	Fuse 2.5 Amp	8636-018-004	8636-018-004	8636-018-004	1
*	Motor, Marathon 50Hz	9376-311-004	9376-317-004	9376-317-004	1
*	Pulley, Motor	9453-169-009	9453-169-014	9453-169-009	1
*	Wiring Label-Schematic/Diagram (Before serial)	9506-644-001	9506-644-001	9506-644-001	1
*	Wiring Label (After Serial #)	9506-964-001	9506-964-001	9506-964-001	1
*	Orifice Main Burner, #30 Natural	9425-069-009	9425-069-009	9425-069-002	4
*	LP Kit	TBR	TBR	TBR	1
*	Gas Valve Assembly	9857-132-004	9857-132-004	9857-132-004	1
*	Kit-Honeywell VR86 Flange Kit 3/4	9732-162-002	9732-162-002	9732-162-002	2
*	Adaptor Assembly Gas Valve	9791-001-001	9791-001-001	9791-001-001	1
*	Manual, Operators (Before Serial #)	8514-234-002	8514-234-002	8514-234-002	1
*	Manual, Operators (After Serial #)	8514-309-001	8514-309-001	8514-309-001	1
*	Hot Surface Warning Label	8502-748-017	8502-748-017	8502-748-017	1
*	Do Not Enter Warning Label	8502-748-001	8502-748-001	8502-748-001	1
*	Explosive Material Warning Label	8502-748-006	8502-748-006	8502-748-006	1
*	Flammable Material Warning Label	8502-748-007	8502-748-007	8502-748-007	1
*	Do Not Operate w/ Guards Removed Label	8502-748-003	8502-748-003	8502-748-003	3
*	Frame/Chassis Ground Label	8502-748-014	8502-748-014	8502-748-014	1
*	Do Not Operate w/ Guards Removed Label	8502-748-004	8502-748-004	8502-748-004	1
*	Electrical Shock Warning Label	8502-748-005	8502-748-005	8502-748-005	1
*	Lockout Warning Label	8502-748-008	8502-748-008	8502-748-008	1
*	Read Operators Manual Label	8502-748-009	8502-748-009	8502-748-009	2
*	PE Mark (Ext. Protective Ground) Label	8502-748-015	8502-748-015	8502-748-015	1

Wiring Schematic for 50hz Dryer -39

CAUTION: LABEL ALL WIRES PRIOR TO DISCONNECTION WHEN SERVICING CONTROLS. WIRING ERRORS CAN CAUSE IMPROPER AND DANGEROUS OPERATION. VERIFY PROPER OPERATION AFTER SERVICING.

9506-589-001A

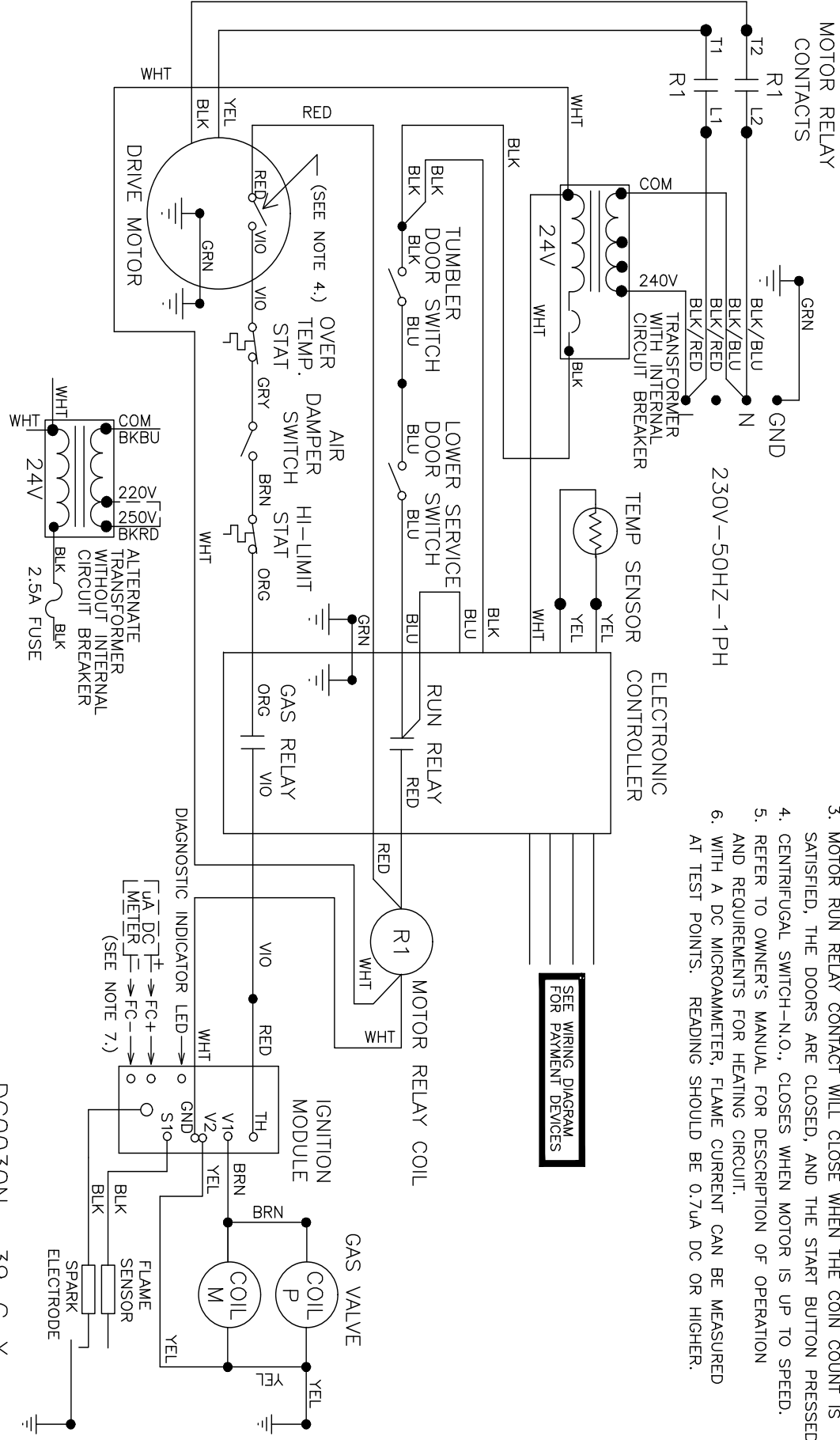

NOTES:

1. COIN SWITCH-N.O., CLOSES WHEN COIN IS INSERTED (SEE SHEET 2).
2. DOOR SWITCHES-N.O., CLOSED WHEN DOORS ARE CLOSED.
3. MOTOR RUN RELAY CONTACT WILL CLOSE WHEN THE COIN COUNT IS SATISFIED, THE DOORS ARE CLOSED, AND THE START BUTTON PRESSED.
4. CENTRIFUGAL SWITCH-N.O., CLOSES WHEN MOTOR IS UP TO SPEED.
5. REFER TO OWNER'S MANUAL FOR DESCRIPTION OF OPERATION AND REQUIREMENTS FOR HEATING CIRCUIT.
6. WITH A DC MICROAMMETER, FLAME CURRENT CAN BE MEASURED AT TEST POINTS. READING SHOULD BE 0.7uA DC OR HIGHER.

SEE WIRING DIAGRAM FOR PAYMENT DEVICES

Wiring Diagram for 50hz Dryer -39

- NOTES:**
1. COIN SWITCH-N.O., CLOSES WHEN COIN IS INSERTED (SEE SHEET 2).
 2. DOOR SWITCHES-N.O., CLOSED WHEN DOORS ARE CLOSED.
 3. MOTOR RUN RELAY CONTACT WILL CLOSE WHEN THE COIN COUNT IS SATISFIED, THE DOORS ARE CLOSED, AND THE START BUTTON PRESSED.
 4. CENTRIFUGAL SWITCH-N.O., CLOSES WHEN MOTOR IS UP TO SPEED.
 5. REFER TO OWNER'S MANUAL FOR DESCRIPTION OF OPERATION AND REQUIREMENTS FOR HEATING CIRCUIT.
 6. WITH A DC MICROAMMETER, FLAME CURRENT CAN BE MEASURED AT TEST POINTS. READING SHOULD BE 0.7uA DC OR HIGHER.

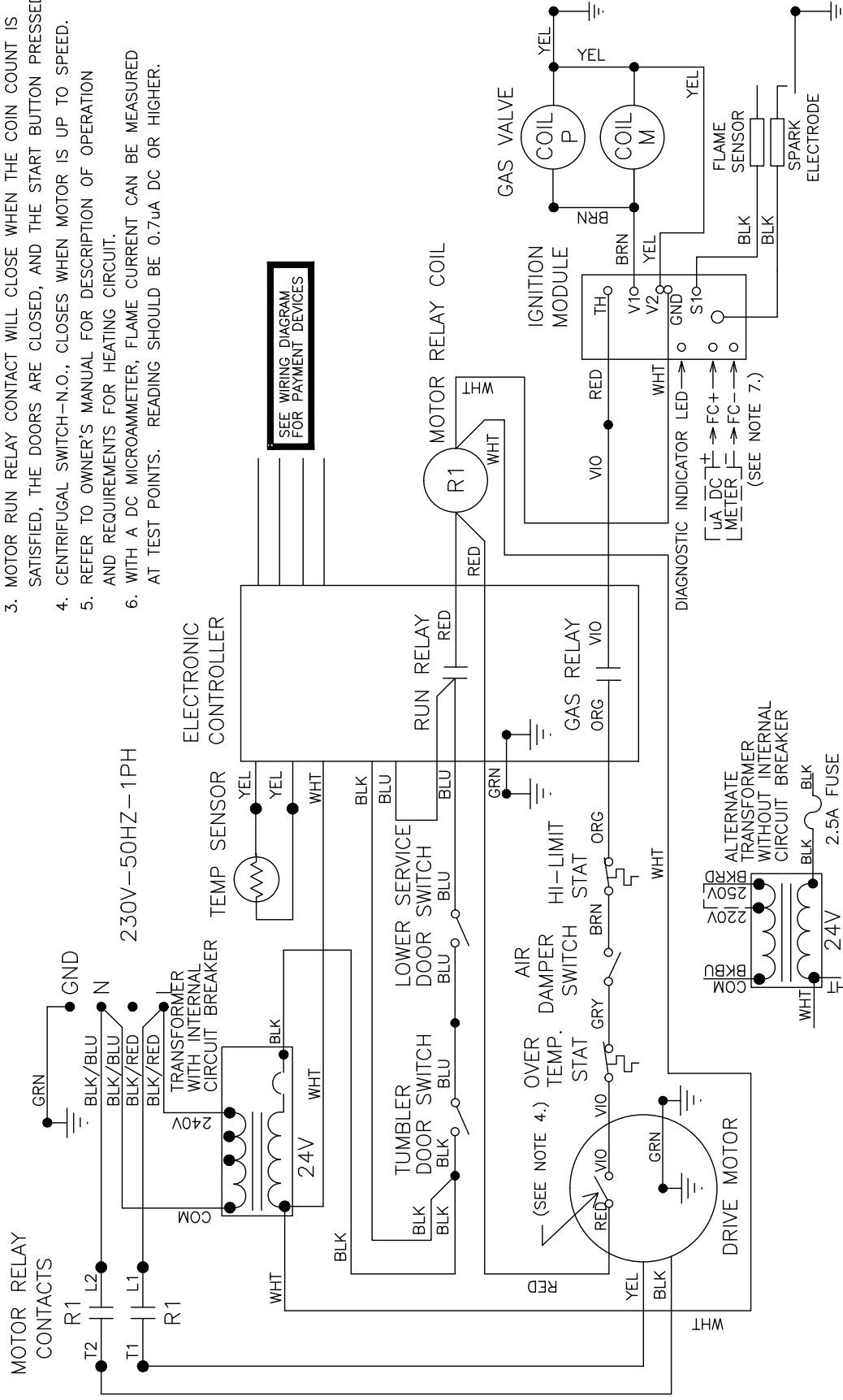

CAUTION: LABEL ALL WIRES PRIOR TO DISCONNECTION WHEN SERVICING CONTROLS. WIRING ERRORS CAN CAUSE IMPROPER AND DANGEROUS OPERATION. VERIFY PROPER OPERATION AFTER SERVICING.

9506-589-001A

SCHEMATIC

DC0030N_-39_C_X
DC0050N_-39_C_X
DC0080N_-39_C_X

Wiring Schematic for 50hz Dryer -59 (After Serial)

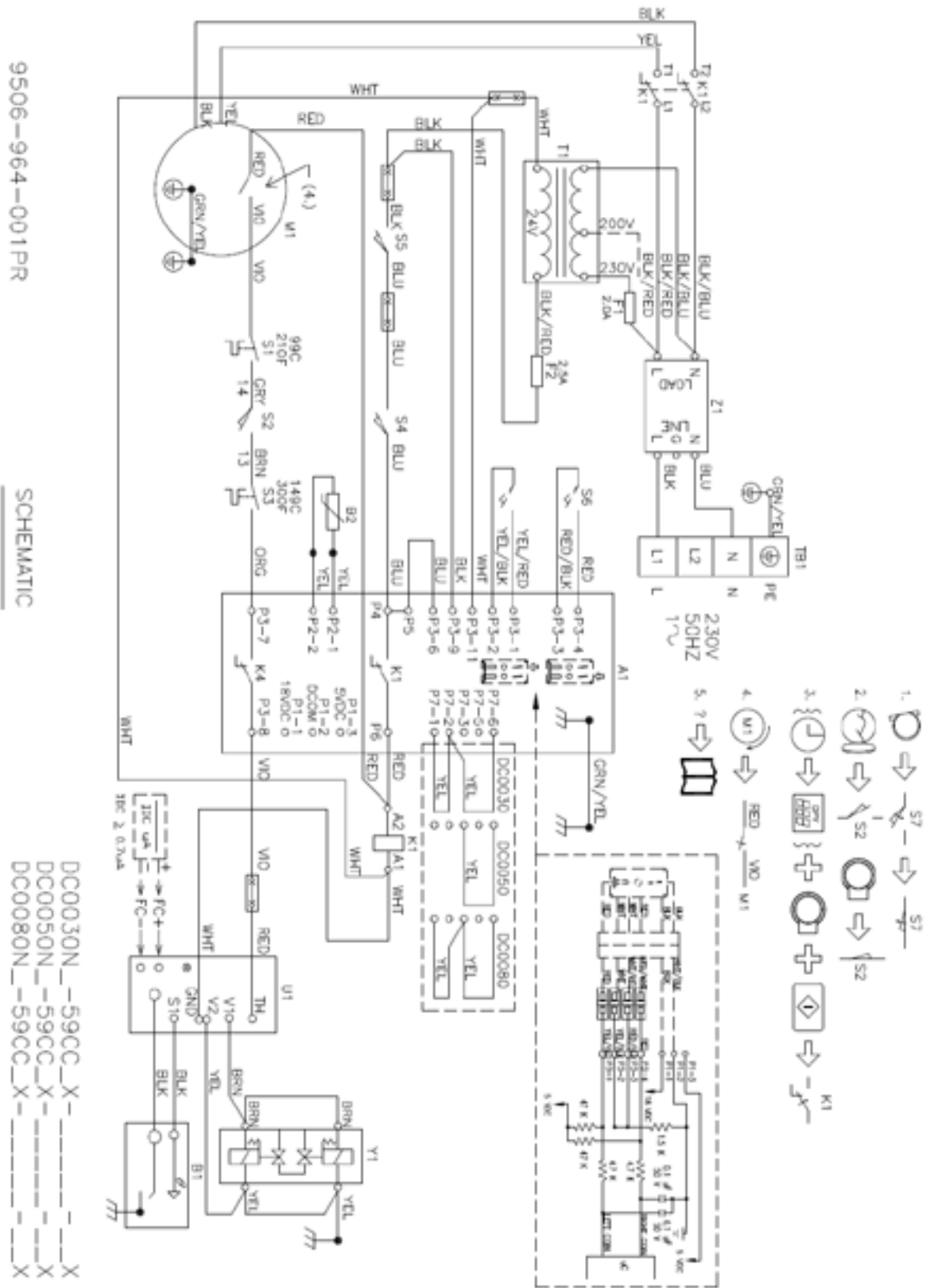

Wiring Diagram for 50hz Dryer -59 (After Serial)

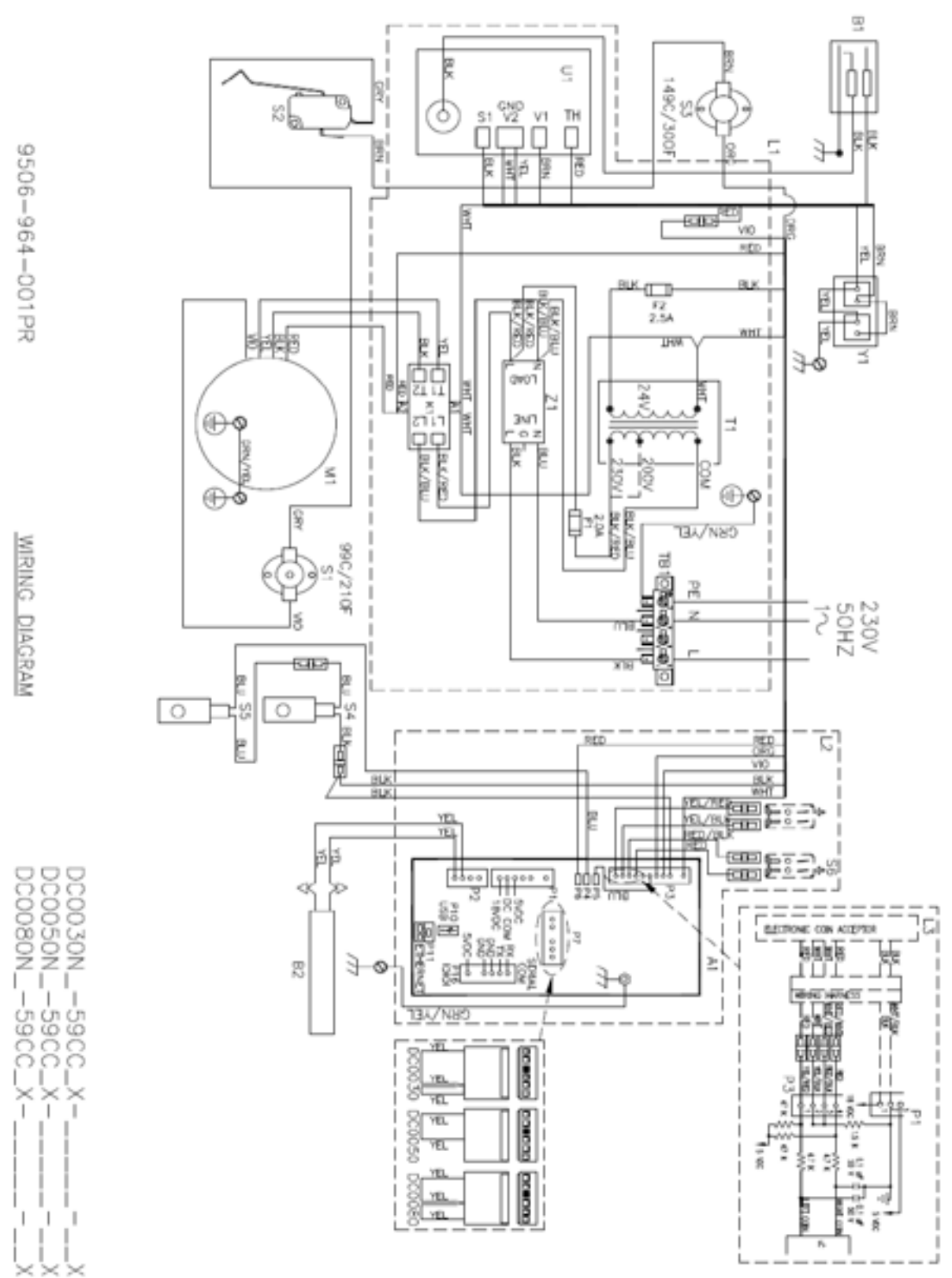

Wiring Schematic for 50hz Dryer -59 (Before Serial)

9506-644-001B

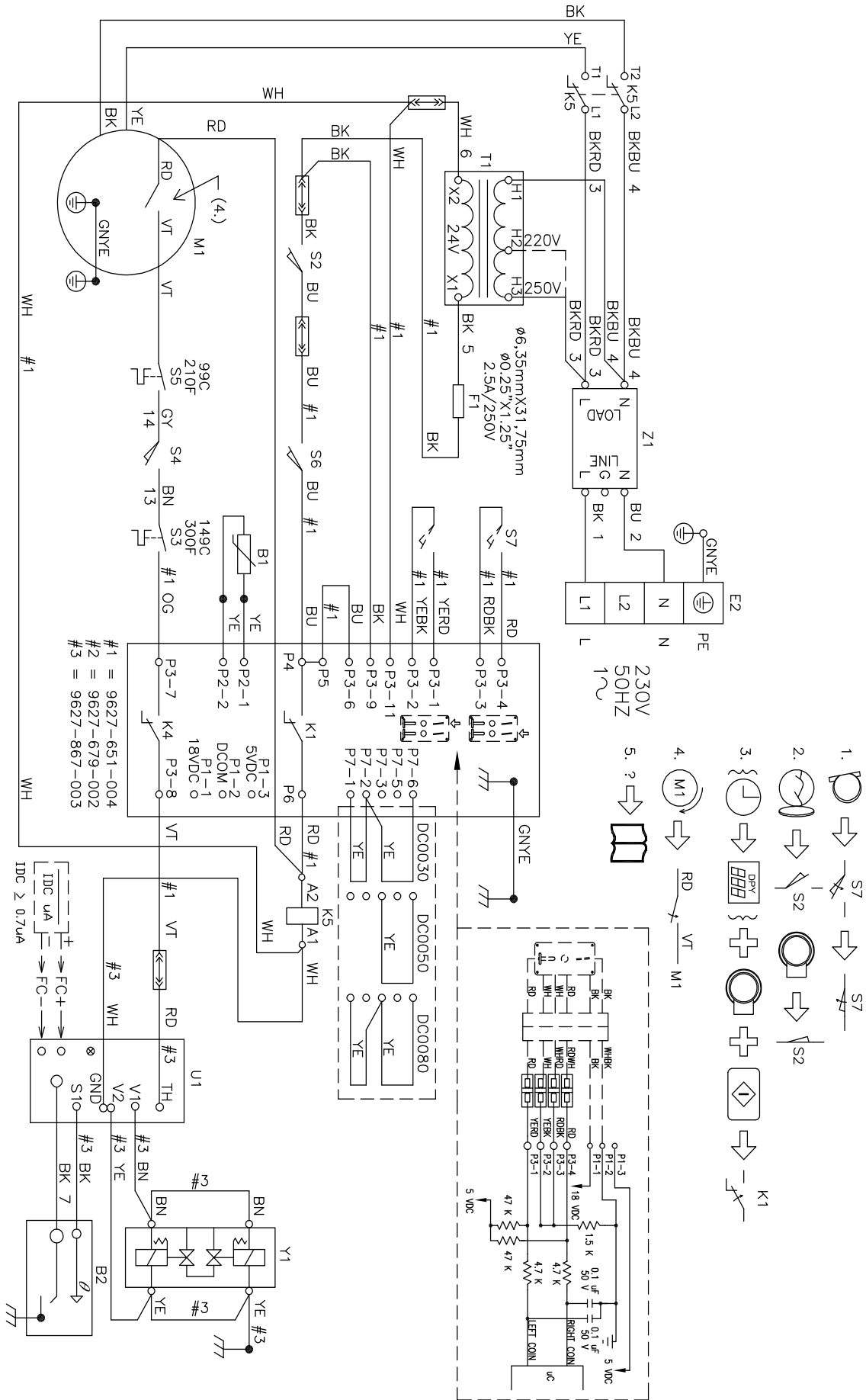

DC0030N -59CC -X -
 DC0050N -59CC -X -
 DC0080N -59CC -X -

Wiring Diagram for 50hz Dryer -59 (Before Serial)

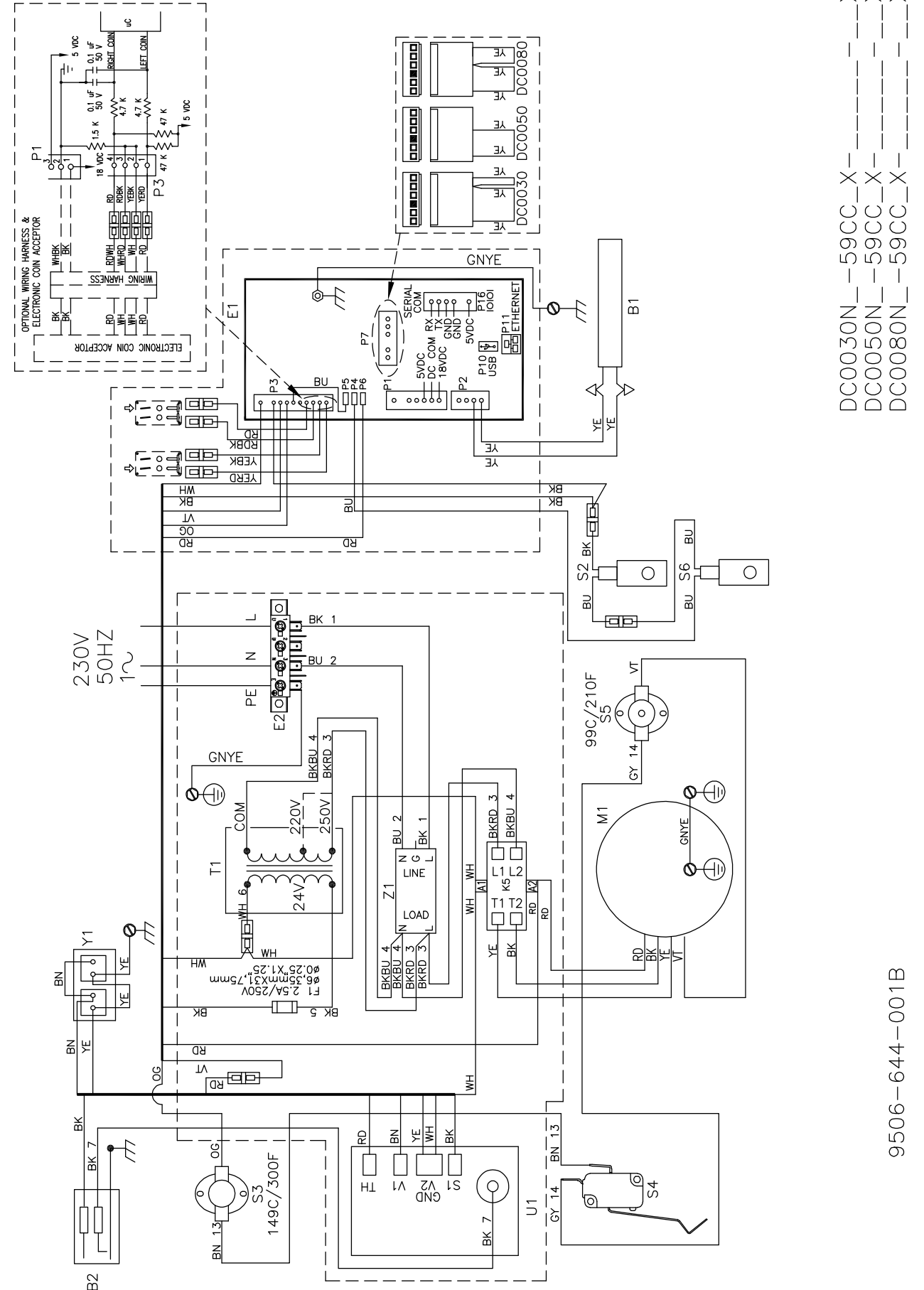

DC0030N -59CC -X -
 DC0050N -59CC -X -
 DC0080N -59CC -X -

9506-644-001B

Section 7:

Maintenance

Schedule

Preventative Maintenance

Daily

- Step 1:** Clean the lint screen free of lint and other debris. Use a soft brush and Hot water if necessary.
- Step 2:** Check the lint screen for tears. Replace if necessary.
- Step 3:** Clean lint from the lint screen compartment.
- Step 4:** Inspect felt seal on lint screen assembly, replace if needed.

Monthly

- Step 1:** Remove lint accumulation from the end bells of the motor.
- Step 2:** Remove lint accumulation from front control area.
- Step 3:** Remove lint and dirt accumulation from the top of the dryer and all areas above, below, and around the burners and burner housing. Failure to keep this portion of the dryer clean can lead to a build-up of lint creating a fire hazard.
- Step 4:** Remove and clean coin acceptors. (Vended Models Only)

Quarterly

- Step 1:** Check the belts for looseness, wear, or fraying.
- Step 2:** Inspect the gasket of the door glass for excessive wear.
- Step 3:** Check tightness of all fasteners holding parts to support channel.
- Step 4:** Check tightness of all set screws.
- Step 5:** Remove the air flow switch assembly and check the tumbler thru-bolts for tightness.
- Step 6:** Apply a few drops of oil to pivot pins and the tension arms where in contact with each other.

Semi-Annually

- Step 1:** Remove and clean the main burners.
- Step 2:** Remove all orifices and examine for dirt and hole obstruction.
- Step 3:** Remove all lint accumulation. Remove the front panel and the lint screen housing and remove lint accumulation.

Annually

- Step 1:** Check the intermediate pulley bearings for wear.
- Step 2:** Check and remove any lint accumulation from the exhaust system including recirculation chambers if applicable.
- Step 3:** Grease the bearings and the shaft of the intermediate pulley. Use an Alemite grease gun and Molykote BR2-S grease. (Where applicable)