

# SOFTMOUNT INDUSTRIAL WASHER MODELS S-675 AND S-975 EXPRESS PLUS ON-PREMISE O-SERIES CONTROL



## OPERATOR'S MANUAL INSTALLATION & OPERATION INSTRUCTIONS

Please read this information and retain for reference.

**WARNING** - THIS WASHER IS EQUIPPED WITH DEVICES AND FEATURES RELATING TO ITS SAFE OPERATION. TO AVOID INJURY OR ELECTRICAL SHOCK, DO NOT PERFORM ANY SERVICING UNLESS QUALIFIED TO DO SO.

IT IS THE RESPONSIBILITY OF THE OWNER TO CHECK THIS EQUIPMENT ON A FREQUENT BASIS TO ASSURE ITS SAFE OPERATION.

A machine should NOT be allowed to operate if any of the following occur:

- Excessively high water level.
- If machine is not connected to a properly grounded circuit.
- If the door does not remain securely locked during the entire cycle.
- Vibration or shaking from an inadequate foundation.

### **WARNING - SAFETY PRECAUTIONS**

- Do not operate washer before removing the shipping braces.
- Always shut off power and water supply before servicing.
- Do not overload the washer.
- Do not open door when cylinder is in motion or it contains water.
- Do not bypass any safety devices of this washer, including the maximum displacement switch.
- Do not use volatile or flammable substances in or near this washer.
- Keep all panels in place. They protect against shock and injury and add rigidity to the washer.

### **PREVENTIVE MAINTENANCE REQUIREMENTS**

#### DAILY

- Check that the loading door remains securely locked and cannot be opened during an entire cycle.
- Clean the top, front, and sides of the cabinet to remove residue.
- Clean the soap dispenser and lid and check that all dispenser mounting screws are in-place and tight.
- Check the loading door for leaks. Clean the door seal of all foreign matter.
- Leave the loading door open to aerate the washer when not in use.

#### QUARTERLY

- Make sure the washer is inoperative by switching off the main power supply.
- Check the suspension springs and dampers for wear. Retighten bolts if necessary.
- Check the V-belts for wear and proper tension.
- Clean lint and other foreign matter from around motor.
- Check all water connections for leaks.
- Check the drain valve for leaking and that it opens properly.
- Wipe and clean the inside of the washer and check that all electrical components are free of moisture and dust.
- Remove and clean water inlet hose filters. Replace if necessary.
- Check anchor bolts (if used). Retighten if necessary.

**IMPORTANT:** Replace all panels that were removed to perform daily and/or quarterly maintenance.

## TABLE OF CONTENTS

1	WASHER SPECIFICATION SHEET .....	3
2	INSTALLATION INSTRUCTIONS .....	4
2.1	FLOORING REQUIREMENTS .....	4
2.2	REMOVAL OF SHIPPING BRACES .....	5
2.3	MACHINE DIMENSIONS: .....	9
2.3.1	S-675 Industrial Washer Dimensions.....	9
2.3.2	S-975 Industrial Washer Dimensions.....	10
2.4	PLUMBING .....	11
2.5	DRAIN.....	11
2.6	PROTECTIVE FILM.....	11
2.7	ELECTRICAL.....	11
2.7.1	INSTALLING THE ELECTRICAL CONNECTION .....	13
2.7.2	FUSING REQUIREMENTS.....	13
2.7.3	CONTROLS TRANSFORMER (208-240V 60 Hz models only) .....	13
2.7.4	CONTROLS TRANSFORMER (230V 50 Hz models only).....	13
2.8	INJECTION SOURCE CONNECTIONS .....	15
2.9	OPERATION CHECK .....	16
2.10	MAXIMUM DISPLACEMENT SWITCH CHECK .....	17
2.11	EXCESSIVE VIBRATION RESET .....	18
2.12	OUT OF BALANCE LOAD.....	21
3	OPERATING INSTRUCTIONS.....	22
3.1	STARTING THE WASHER.....	22
3.2	END OF CYCLE .....	22
3.3	EMERGENCY STOP / SAFETY DOOR LOCK.....	23
3.4	VARIABLE FREQUENCY DRIVE INDICATORS.....	24
4	MACHINE PROGRAMMING INSTRUCTIONS .....	25
4.1	ENTER PROGRAMMING MODE.....	25
4.2	WATER LEVEL PROGRAMMING .....	25
5	WASHER ERROR MESSAGES .....	26
6	TROUBLESHOOTING – REVIEW FOR NEEDED CHANGES .....	36
7	TRANSIENT VOLTAGE SURGE SUPPRESSORS .....	40
8	SERVICE AND PARTS.....	41

# 1 WASHER SPECIFICATION SHEET

		S-675		S-975	
Capacity	Dry Weight Capacity - lb (kg)	40	(18.1)	60	(27.2)
	Cylinder Volume - cu ft (L)	6	(170)	9	(254.9)
Speed	High Extract Speed - g (RPM)	400	(1061)	400	(969)
	Intermediate Extract Speed - g (RPM)	60	(411)	60	(375)
	Washing Speed - g (RPM)	0.9	(43)	0.9	(43)
	Motor Size - hp (kW)	3	(2.2)	6.7	(5)
Dimensions	Cabinet Height - in (cm)	52 9/16	(133.5)	58	(147.3)
	Cabinet Width - in (cm)	33	(83.8)	38 1/4	(97.2)
	Cabinet Depth - in (cm)	40	(101.6)	43	(109.2)
	Door Opening - in (cm)	15 1/4	(38.7)	19 1/4	(48.9)
	Floor to Door Bottom - in (cm)	19 15/16	(50.7)	21 3/8	(54.4)
	Cylinder Diameter - in (cm)	25	(63.5)	30	(76.2)
	Cylinder Depth - in (cm)	21 1/8	(53.7)	22	(55.9)
	Static Load Transmitted - lb (kg)	1040	(471.7)	1456	(660.4)
	Dynamic Load Transmitted - lb (kg)	368	(166.9)	460	(208.7)
	Dynamic Load Frequency - Hz	17.7	-	16.1	-
Weight	Net Weight - lb (kg)	902	(409.1)	1250	(567)
Shipping	Shipping Weight - lb (kg)	952	(431.8)	1300	(589.7)
	Shipping Height - in (cm)	58 3/4	(149.2)	64 1/4	(163.2)
	Shipping Width - in (cm)	34 3/4	(88.3)	40	(101.6)
	Shipping Depth - in (cm)	50	(127)	50	(127)
Water	Water Inlet Size - in (mm)	3/4	(19)	3/4	(19)
	Pressure (min-max) - psi (kPa)	30-120	(207-827)	30-120	(207-827)
	Flow Rate - gal/min (L/min)	9	(34)	9 & 12	(34 & 45)
	Drain Diameter (O.D.) - in (cm)	3	(7.6)	3	(7.6)
	Floor to Center of Drain - in (cm)	4 1/8	(10.5)	4 1/8	(10.5)
Electrical	Model	Volts / Hz / Phase / Wiring	Circuit Breaker Amps / Running Amps / Wire Size	Circuit Breaker Amps / Running Amps / Wire Size	
	-12	208-240 / 60 / 1 / 2 wire + ground	15 / 10 / #12	30 / 15 / #10	
		208-240 / 60 / 3 / 3 wire + ground			
-39	230 / 50 / 1 / 2 wire + ground	15 / 10 / 3.5 mm2	30 / 15 / 5.3 mm2		
Installation	Min. Clearance Between Machines - in (cm)	1/2	(1.3)	1/2	(1.3)
	Min. Clearance Behind Machines - in (cm)	24	(61)	24	(61)

## 2 INSTALLATION INSTRUCTIONS

All washers must be installed in accordance with all local, state and national building, electrical, plumbing and other codes in effect in the area.

**WARNING:**  
**THESE INSTALLATION AND SERVICING INSTRUCTIONS ARE FOR USE BY QUALIFIED PERSONNEL ONLY. TO AVOID INJURY AND ELECTRICAL SHOCK, DO NOT PERFORM ANY SERVICING OTHER THAN THAT CONTAINED IN THE OPERATING INSTRUCTIONS, UNLESS QUALIFIED.**

### 2.1 FLOORING REQUIREMENTS

It is recommended that this machine be installed on a level concrete floor. Concrete should have a minimum strength of 4,000 psi.

Do not install the washer on suspended floors or above open basements without consulting with a qualified structural engineer. The flooring must be adequate to support the static and dynamic loading of the washer (see specifications section).

Allow a minimum of 24 inches (610 mm) of clearance behind the rear of the machine to provide access for motor service.

Do not install on any type of anti-vibration materials or devices.

It is recommended to also install two mounting bolts to anchor the machine against possible movement. The anchors should be installed through the 1/2" wide slots in the corner mounting plates on the machine base (using two opposite corners). See machine dimensions section.

As an extra installation aid, the S-975 anchor pattern can be found on the back panels of the washer and can be used as a template. (Not applicable to the S-675).

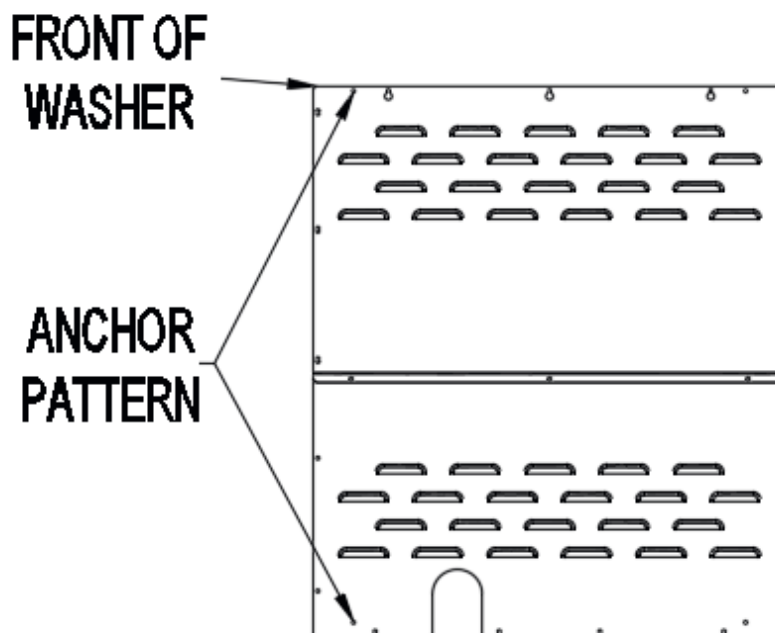

## 2.2 REMOVAL OF SHIPPING BRACES

Do not remove the shipping braces before placing the machine in its installed location.

Do not run the machine with the shipping braces in place. Severe damage and physical injury may occur.

Steps to remove the (5) shipping braces:

- Remove the lower service panel on the front of the washer and the lower panel on the rear of the washer.
- On the rear of the washer, remove the (4) screws that secure the white triangular shaped brace to the frame as shown below:

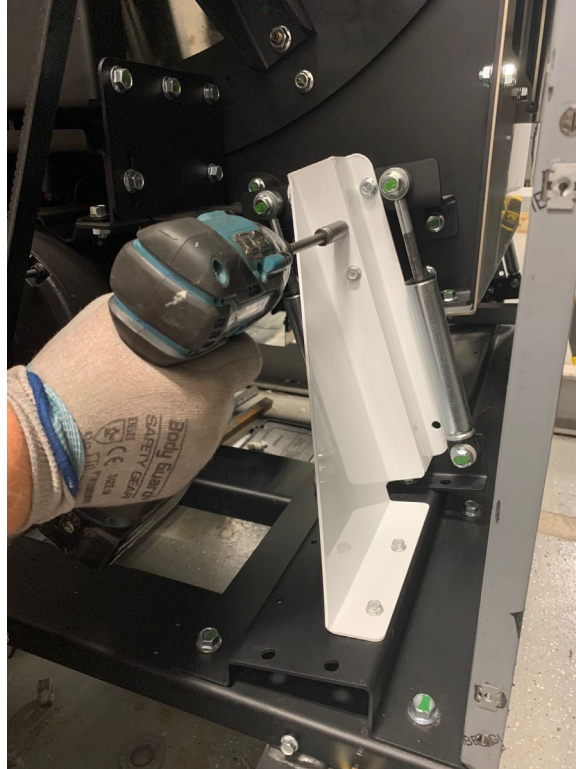

- Next, remove the white hat-shaped brace from this corner of the frame by removing (3) bolts and nuts as shown below (Do not remove or loosen the bolts that secure the dampers (shocks)):



- Next, remove the white hat-shaped brace from the other rear corner of the frame by removing (3) bolts and nuts as shown below (Do not remove or loosen the bolts that secure the dampers (shocks)):



- Next, remove the white hat-shaped brace from the front corner of the frame by removing (3) bolts and nuts as shown below (Do not remove or loosen the bolts that secure the dampers (shocks)):



- Next, remove the white hat-shaped brace from the other front corner of the frame by removing (3) bolts and nuts as shown below (Do not remove or loosen the bolts that secure the dampers (shocks)):



- Save all (5) braces and fasteners. If the machine needs to be moved in the future, replace all braces before moving it.
- Re-install the lower service panel on the front of the washer and the lower panel on the rear of the washer.



## 2.3 MACHINE DIMENSIONS:

### S-675 INDUSTRIAL SOFTMOUNT WASHER DIMENSIONS

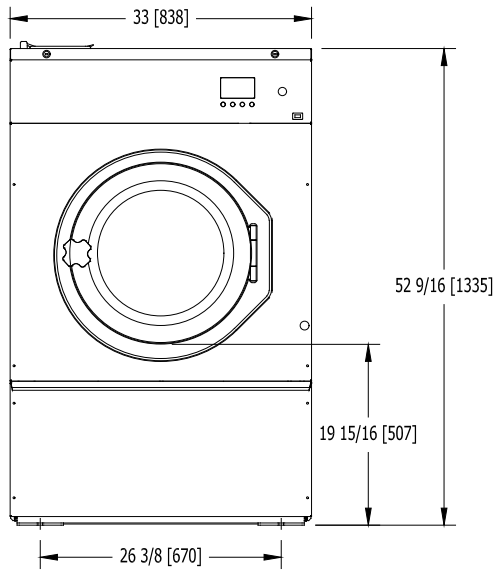

FRONT

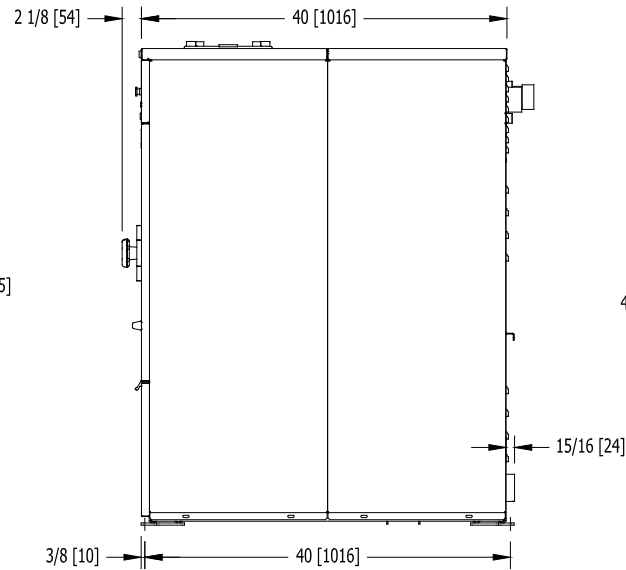

SIDE

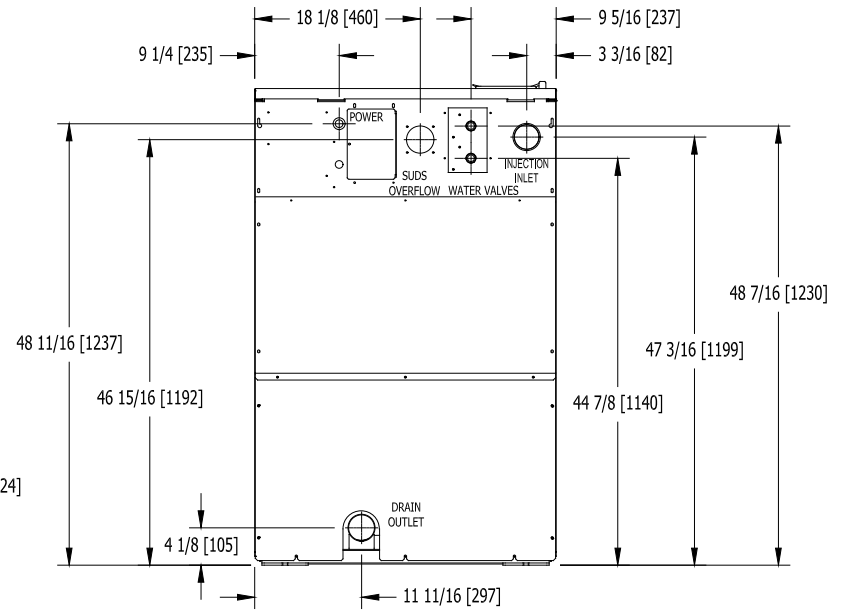

REAR

#### 2.3.1 S-675 Industrial Washer Dimensions

S-975 INDUSTRIAL SOFTMOUNT  
WASHER DIMENSIONS

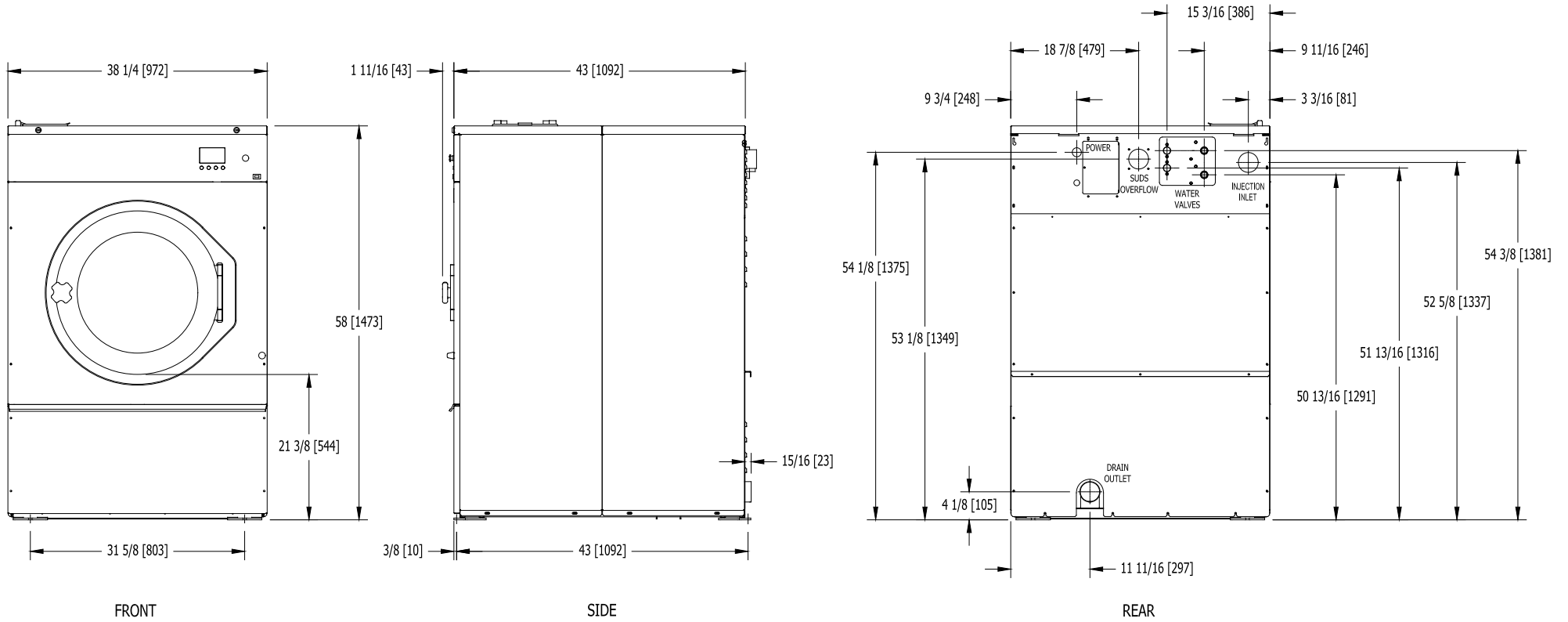

2.3.2 S-975 Industrial Washer Dimensions

## 2.4 PLUMBING

Water supply hoses are provided with each machine. The threaded connections on the hoses are  $\frac{3}{4}$ -11  $\frac{1}{2}$  NHT.

Separate hot and cold water lines must be supplied to the machine, maintaining 30 psi to 120 psi (207 kPa to 827 kPa) water flow pressure. A 140°F (60°C) hot water supply is recommended for best washing results. Do not exceed 180°F (82°C) water temperature.

## 2.5 DRAIN

The drain outlet tube size is 3 inches (76 mm) in diameter

Any drain hose used must be lower than the drain valve to assure proper draining.

## 2.6 PROTECTIVE FILM

The machine may have protective adhesive film on the front control panel label area and on the front, top, and side stainless steel panels. The film may be peeled off before putting the machine into service.

## 2.7 ELECTRICAL

The Dexter single/three-phase 208-240VAC 60 Hz (single phase 230VAC 50 Hz) non-heated washing machines are intended to be permanently installed appliances. No power cord is provided. The machine should be connected to an individual branch circuit not shared by lighting or other equipment. A means for disconnection with a contact separation of at least 1/8" (3 mm) must be provided. The connection should be sheathed in liquid-tight or approved flexible conduit, or equivalent, with conductors of the proper size and insulation (50 Hz: The sheath of the supply cord must be at least equivalent to that of a cord complying with IEC 227 or IEC 245). A qualified technician should make such connections in accordance with the wiring diagram. See specification sheet for minimum recommended wire size.

Individual circuit breakers for each unit are required. Do not use ground-fault (earth-fault) circuit breakers or ground-fault (earth-fault) circuit interrupter outlets.

**WARNING:**  
**SHUT OFF POWER AND WATER BEFORE OPENING ANY SERVICE PANELS.**

200-250 VAC  
POWER  
CONNECTIONS

L1

L2

L3

N

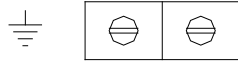
120 VAC (60HZ)  
OR 24 VAC (50HZ)  
INJECTOR  
SUPPLY  
SIGNALS

#10

#9

#8

#7

#6

#5

#4

#3

#2

#1

COM

**ELECTRICAL CONNECTIONS**

### 2.7.1 INSTALLING THE ELECTRICAL CONNECTION

- 2.7.1.1 Disconnect all power to the washer.
- 2.7.1.2 Remove the terminal block cover on the back of the washer.
- 2.7.1.3 If power is 208-240V-**3PH**-60Hz, connect L1, L2, L3 and Ground. If there is a high leg, it must NOT be connected to L1 or L2. However, failure due to a voltage surge on the high leg is not covered by equipment warranty. Contact Dexter Laundry with any questions.
- 2.7.1.4 If power is 208-240V-**1PH**-60Hz, connect L1, L2 and Ground.
- 2.7.1.5 If power is 230V-**1PH**-50Hz, connect L1, N and Earth.

NOTE: It is important that the grounding screw next to the power terminal block be connected to a good external ground.

### 2.7.2 FUSING REQUIREMENTS

Single- and Three -phase models:

See specification sheet for required TIME-DELAY (DUAL ELEMENT) FUSE size (or equivalent circuit breaker)

### 2.7.3 CONTROLS TRANSFORMER (208-240V 60 Hz models only)

The controls transformer is located inside the control trough and steps a range of 208 to 240 volts down to 115 volts and 24 volts. There are two terminals on the controls transformer for the primary (incoming) power. Use the terminal marked "208V" for power supplies between 208 and 219 volts. Use the terminal marked "240V" for power supplies between 220 and 240 volts. Refer to the following for control transformer connections.

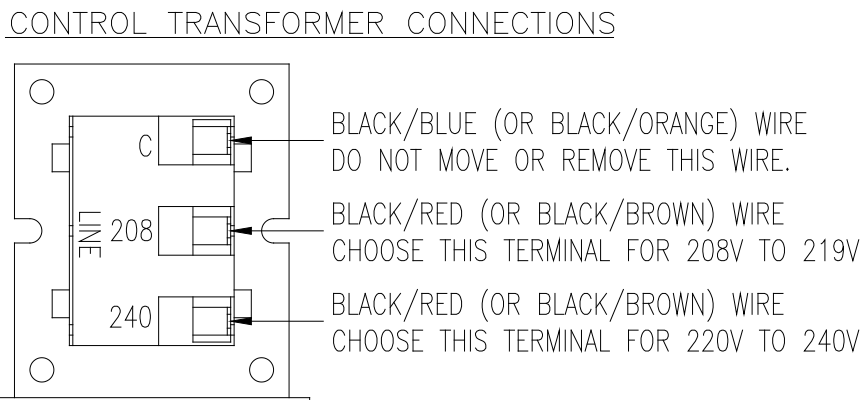

### 60 Hz Control Transformer Connections

### 2.7.4 CONTROLS TRANSFORMER (230V 50 Hz models only)

The controls transformer is located inside the control trough and steps a range of 180 to 255 volts down to 24 volts. There are two terminals on the controls

transformer for the primary (incoming) power. Use the terminal marked "L1 200V" for power supplies between 180 and 229 volts. Use the terminal marked "L1 230V" for power supplies between 230 and 255 volts.

CONTROL TRANSFORMER CONNECTIONS

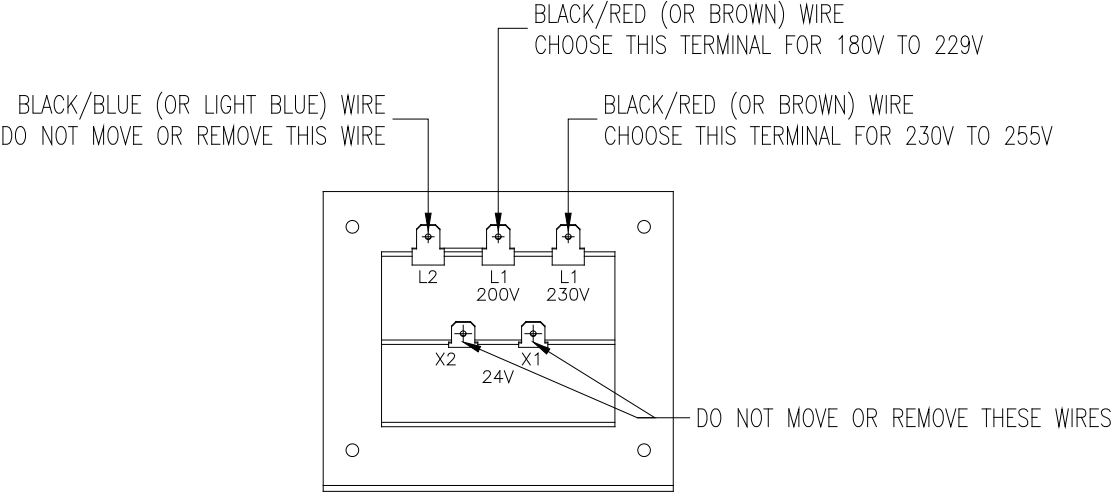

**50 Hz Control Transformer Connections**

## 2.8 INJECTION SOURCE CONNECTIONS

The washer control may be programmed to send ten 120VAC output signals for 60Hz models (or 24VAC for 50Hz) for a chemical injection system. The signals are not intended as a power source and must be limited to less than 100 milliamps of current. There is a separate terminal block for connection of the external injection signals. For the injection sources, program codes 1 through 10 and their respective terminal block connections are as shown in the table below.

Dexter Recommended Connections	Controller / Injector Signals
Detergent	1
Bleach	2
Starch	3
Sour/Softener	4
	5
	6
	7
	8
	9
	10

### **Injection Signal and Circuit Identification**

If required, chemical injection hoses are to be inserted into the injection inlet at the upper right rear of the washer. These hoses should be inserted into the round PVC pipe a distance of a minimum of 22" (56 cm) and a maximum of 26" (66 cm).

This will eliminate chemical buildup in the pipe and/or restrict water flow to the tub. Secure the hoses as required.

## 2.9 OPERATION CHECK

After all mounting, plumbing and electrical work is completed, select any desired wash cycle and run the machine through a complete wash cycle. Check for water leaks and verify proper operation.

During intermediate spin and final spin, the cylinder should turn in a **counterclockwise** direction when viewed from the front of the machine. If spin is clockwise, the T1 and T2 motor wires connecting to terminal T1 and T2 on the variable frequency drive should be swapped. Remove power to the machine before opening service panels and swapping wires.



## 2.10 MAXIMUM DISPLACEMENT SWITCH CHECK

After the washer is properly installed, the maximum displacement switch should be checked for functionality.

The switch (black plunger) is located behind the front panel on the left side of the washer tub.



**WARNING – DO NOT** bypass this switch to operate the washer

First check that the switch is fully pulled out, then start a wash cycle. Carefully push in the plunger on the switch. When the plunger is pushed in, the cycle should stop, the drain valve will open, and the display will show a message that the switch has been tripped.

For the Red Screen "Excessive Vibration" error see Section 2.11 and for the Black Screen "Out of Balance Load" message see Section 2.12.

## 2.11 EXCESSIVE VIBRATION RESET

If a clothes load is excessively out of balance, the maximum displacement switch could be tripped during operation due to excessive tub movement. This screen indicates that the switch has been tripped and that the washer will need to be reset:



To reset the washer, first pull out the plunger on the switch as shown in the previous section and then follow the instructions on the display to reset the washer.

Enter the management section by pressing the green start button. Enter the 4-digit management passcode using the arrow keys to change the number and the start button to select each number. After entering the 4 digits, press start to confirm:

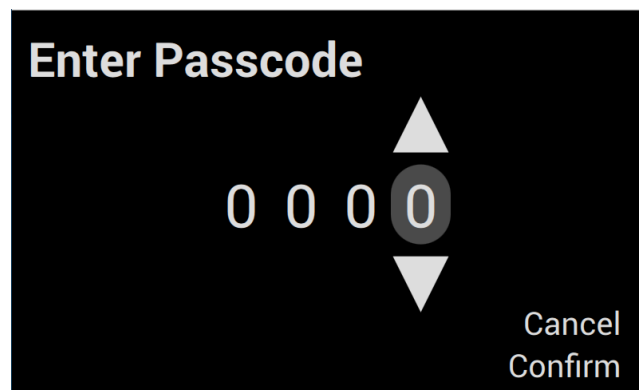
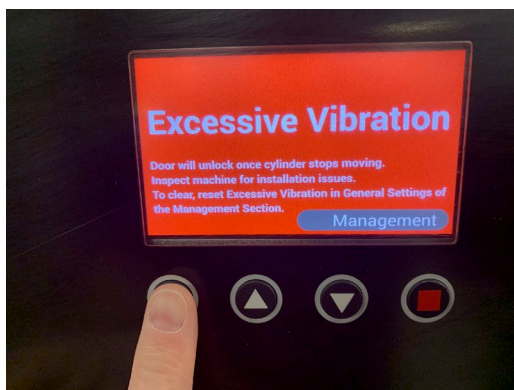

Scroll down using the arrow button to "General Settings" then press the start button:

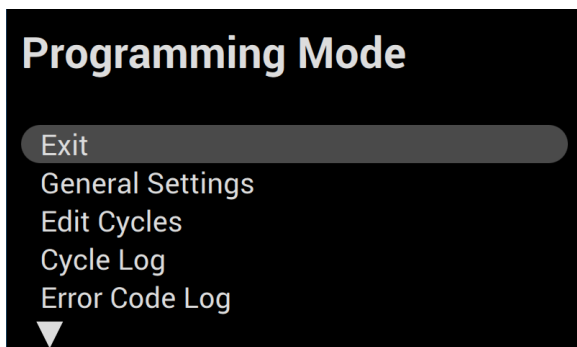

Scroll down using the arrow button to "Excessive Vibration" then press the start button:

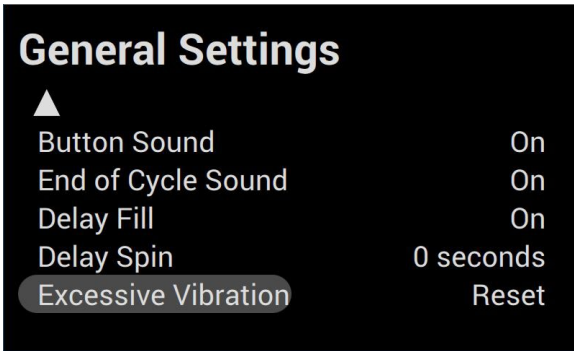

Press the down arrow button to change from "Reset" to "Ready", then press the start button:

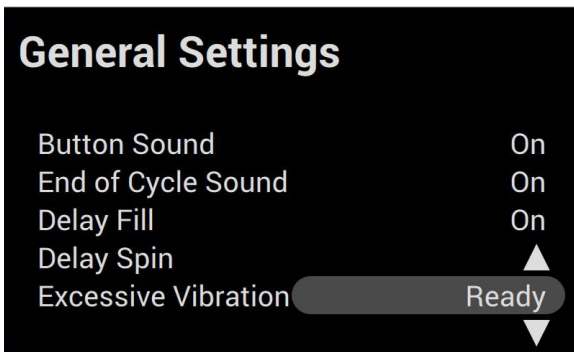

Press the red stop button to exit this screen. Press the red stop button a second time until the screen below appears. Press the down arrow to change from "Cancel" to "Confirm" and then press the green start button to confirm and save the change:

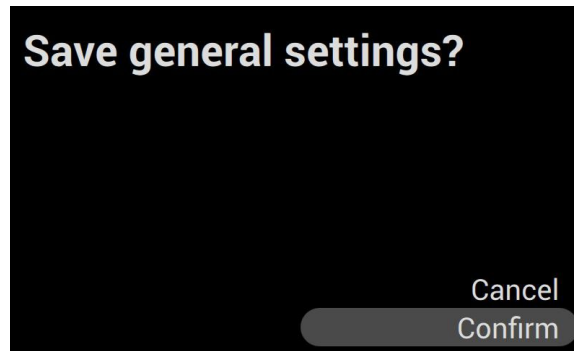
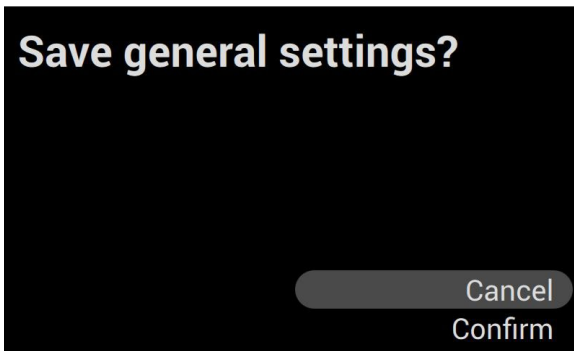

Press stop button to exit this screen. Continue to press the stop button until you have returned to the Ready screen:

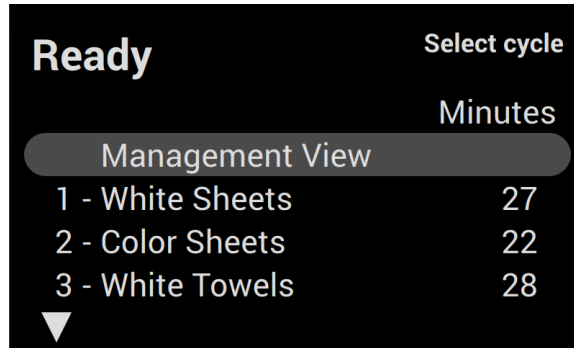
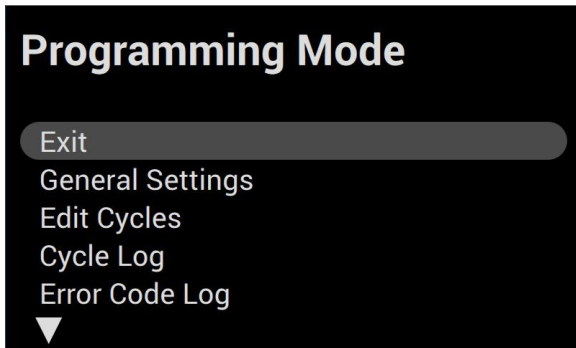

The washer may display the red Excessive Vibration screen a second time:



If so, please repeat the previous steps on the screen to reset the washer. You will not need to physically reset the plunger on the switch a second time.

## 2.12 OUT OF BALANCE LOAD

During a spin, this message may be displayed:

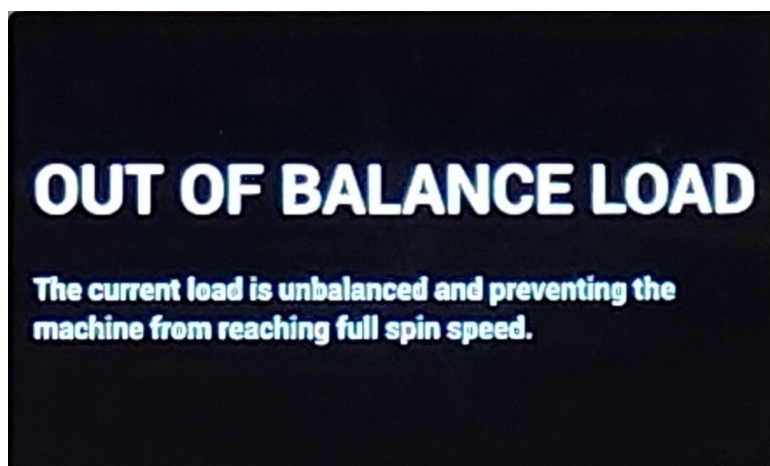

This is a normal message when the washer is attempting to better distribute an out of balance clothes load before accelerating to the full spin speed. You do not need to stop the cycle or reset the washer.

The washer will slow back down, re-tumble the clothes and then attempt to reach the full spin speed again.

In any wash stage that isn't the final rinse, the washer will attempt to spin, redistribute if it is out of balance, and then attempt the spin a second time. If the second attempt is also out of balance, the washer will progress to the next stage in the wash cycle.

During the final rinse stage, the washer will attempt to spin, redistribute if it is out of balance, and then attempt to spin again. If still out of balance, redistribution attempts will be repeated. If the clothes load is still out of balance after a fourth try, it will stop attempting to go into spin and will agitate for the remainder of the cycle time and the cycle will end.

### **3 OPERATING INSTRUCTIONS**

#### **3.1 STARTING THE WASHER**

*3.1.1 Turn on power to the washer.*

*3.1.2 Load the laundry.*

Place laundry into the cylinder and latch the door securely by pushing the door close and then turning the door handle counterclockwise. Be sure laundry does not get caught between the door gasket and tub front when closing the door. Maximum load is the dry weight capacity listed in the specification sheet. Do not exceed the listed capacity weight.

*3.1.3 Select wash cycle.*

Select the appropriate cycle for the type of load being washed. Use the "UP" and "DOWN" keys to change the cycle on the display to the desired cycle and press the enter button to select.

*3.1.4 Add washing chemicals.*

If not using a chemical injection system, add low sudsing powdered detergent into the "DETERGENT" compartment of the automatic dispenser on the top of the washer.

If liquid wash products are used in the "DETERGENT" compartment, they must be added at the beginning of the wash cycle.

If desired, add fabric softener to the "FABRIC SOFTENER" compartment. Use the amount of fabric softener as recommended by the manufacturer.

If the machine is set for pre-wash, washing products can be added to the round opening of the dispenser or put in with the clothes when loading the washing machine.

If bleach is desired, DO NOT place into dispenser until the ADD BLEACH message is displayed.

*3.1.5 Start wash cycle.*

Press enter to start the cycle. The display will show cycle information throughout the cycle. The door will lock and remain locked until the end of the cycle.

*3.1.6 Pause wash cycle / End wash cycle*

Press the red pause button to pause the cycle. Select Start to restart the cycle or select Cancel Cycle to end the wash cycle.

#### **3.2 END OF CYCLE**

A tone will sound (if programmed) and the display will indicate that the cycle has ended. The door can now be opened. Immediately remove contents of washer. Leave the door open when the machine is not in use.

### 3.3 EMERGENCY STOP / SAFETY DOOR LOCK

This machine is equipped with a safety door lock that locks the door when the cycle is started until the cycle is complete. The door lock prevents opening the door if the power is interrupted during the cycle.

The Emergency Stop button ends the cycle and allows the door to be opened after the Safety Door Lock releases. When the Emergency Stop button is pressed an alarm will sound (if programmed), an "Emergency Stop" message will be displayed, tumbler movement will begin to slow and water will begin draining from inside the washer. Though the machine may end movement quickly, it may take up to 15 seconds for the door to unlock. During that time the alarm will continue to sound. When the alarm stops, the door may be opened. Inspect the washer as needed and reset the emergency stop button by turning it clockwise. Reset the washer by selecting Cancel. The washer may be restarted by closing and latching the door and starting a new cycle.

If power is lost during a cycle the door will remain locked. The door lock can be manually released. Before doing so, check that the drum is not in motion and there is no water in the drum. To unlock the door, insert a small rod of a diameter less than .157" (4mm) firmly into the hole shown below and then turn the door handle clockwise to open.



**WARNING** – NEVER open the door in this way while the cylinder is in motion or during normal operation.

### 3.4 VARIABLE FREQUENCY DRIVE INDICATORS

There are three small colored LEDs located on the upper region of the Variable Frequency Drive (VFD). They are labeled as "READY", "RUN", and "FAULT" and can be used for troubleshooting. The definitions of the LEDs are listed in the table below.



LED Status	Washer Condition
Steady Yellow	Tumbling
Blinking Yellow	Stop from Tumble
Steady Yellow	Ramp to Intermediate or Final Extract Spin
Steady Yellow	Spinning (Intermediate or Final)
Blinking Yellow	Stop from Spin (Intermediate or Final)
Steady Green	Idle Mode (No Cylinder Movement)
Steady Red	VFD fault
Blinking Red	VFD warning

**Variable Frequency Drive Indicators**



## **4 MACHINE PROGRAMMING INSTRUCTIONS**

### **4.1 ENTER PROGRAMMING MODE**

*4.1.1 In the cycle selection screen, scroll to Management View at the beginning of the cycle list and select enter.*

*4.1.2 Enter Passcode and confirm by pressing enter.*

*4.1.3 Select desired option.*

#### **4.1.3.1 Example EDIT CYCLES**

Cycles may be edited in the Edit Cycles selection. Within Edit Cycles, cycles may be edited, copied, reordered or deleted.

After making edits, select Back/Exit until out of the option. Confirm changes when prompted to do so. When finished, select Back/Exit until you have returned to the cycle selection screen.

### **4.2 WATER LEVEL PROGRAMMING**

The water level of each bath can be adjusted in programming mode by editing cycles. The levels are adjustable from 1 to 10. The following shows the equivalent values to previous models with Low and High OPL water levels:

- 1
- 2
- 3 (Low)
- 4
- 5
- 6
- 7
- 8
- 9
- 10 (High)

The dip switches on the water pressure sensor board DO NOT adjust water levels on this product.

## 5 WASHER ERROR MESSAGES

The O-Series washer control reacts to various abnormal conditions by displaying an Error message. These messages usually contain the "Error" text, and then a general description of the message. Below is a listing of Error messages separated by each potential displayed message in bold face. Each is followed by:

- Condition that creates the displayed message on the control
- Action that the control takes responding to the condition
- Exit is the method the user (or the control) should use to bring the machine back to normal operation.

The actual displayed message on the control may contain the general description listed below and additional details (such as number or additional text). However, the condition, action or exit qualities of the error message should be the same for all variations.

<b>OPERATION IN PROGRESS</b>	
Condition	This error occurs when the user is attempting to start a machine operation while another operation is ending.
Action	When detected, the control does not respond to user input on the buttons. There is no delay in the action once the criteria are met. The control will finish the current operation while displaying "OPERATION IN PROGRESS". Once the operation is complete, the error will no longer be displayed and the control will respond to user input normally.
Exit	The error will be reset automatically once the current operation is complete.
<b>POWER LOSS</b>	
Condition	This error occurs when the Main Control Board detects a total loss of 24VAC power.
Action	When detected, the control turns off the motor and all relays. There is no delay in the action once the criteria are met.
Exit	The machine will not start and the Error Code will continue to be displayed until the condition is no longer present. Once the condition is removed, the machine still will not start and the Error Code will continue to be displayed until the prompt is followed to Reset the Error and return the machine to Idle Mode.
<b>BROWN OUT</b>	
Condition	This error occurs when the Main Control Board detects less than 21VAC at the 24VAC input.
Action	When detected, the control turns off the motor and all relays. There is no delay in the action once the criteria are met.
Exit	The machine will not start and the Error Code will continue to be displayed until the condition is no longer present. Once the condition is removed, the machine still will not start and the Error Code will continue to be displayed until the prompt is followed to

	Reset the Error and return the machine to Idle Mode.
<b>TEMP SENSOR SHORT</b>	
Condition	This error occurs when the control detects a short circuit from the temperature sensor.
Action	When detected, the control turns off the motor and all relays. There is no delay in the action once the criteria are met.
Exit	The machine will not start and the Error Code will continue to be displayed until the condition is no longer present. Once the condition is removed, the machine still will not start and the Error Code will continue to be displayed until the prompt is followed to Reset the Error and return the machine to Idle Mode.
Note	This error code is disabled if the washer model does not have a temperature sensor
<b>TEMP SENSOR OPEN</b>	
Condition	This error occurs when the control detects an open circuit from the temperature sensor.
Action	When detected, the control turns off the motor and all relays. There is no delay in the action once the criteria are met.
Exit	The machine will not start and the Error Code will continue to be displayed until the condition is no longer present. Once the condition is removed, the machine still will not start and the Error Code will continue to be displayed until the prompt is followed to Reset the Error and return the machine to Idle Mode.
Note	This error code is disabled if the washer model does not have a temperature sensor
<b>NO HEAT RISE</b>	
Condition	This error occurs when the control detects that the temperature is not increasing.
Action	When detected there is a delay of 15 minutes before the error is active. Once active, the control will display the "NO HEAT RISE" prompt, alternating with the normal Cycle Progress screen at a rate of 5 seconds on, 5 seconds off. The heating relay will also be turned off. Otherwise the cycle will continue normally.
Exit	The Error Code will continue to be displayed until the in-progress cycle is stopped and the control is returned to Idle Mode. It will then reset automatically.
Note	This error code is disabled if the washer model does not have an Auxiliary Heating option
<b>HEAT RISE OUT OF RANGE</b>	
Condition	This error occurs when the control detects that the operating temperature is greater than 220 degrees F (or 104 degrees C).
Action	When detected, the control will display the "HEAT RISE OUT OF RANGE" prompt, alternating with the normal Cycle Progress screen at a rate of 5 seconds on, 5 seconds off. The heating relay

	will also be turned off. Otherwise the cycle will continue normally. There is no delay in the action once the criteria are met.
Exit	The Error Code will continue to be displayed until the in-progress cycle is stopped and the control is returned to Idle Mode. It will then reset automatically.
Note	This error code is disabled if the washer model does not have an Auxiliary Heating option
<b>NO PROX SENSOR OUTPUT</b>	
Condition	This error occurs when the machine control does not detect output from the proximity sensor(s) when the cylinder has been commanded to turn.
Action	When detected, there is a short delay before the error is active. When active, the control turns off the motor and all relays.
Exit	The machine will not start and the Error Code will continue to be displayed until the prompt is followed to Reset the Error Code and return the Machine to Idle Mode.
<b>PROX SENSOR OUT OF RANGE</b>	
Condition	This error occurs when the machine control sees output from the proximity sensor(s) that does not fall in the acceptable range for the particular washer or dryer model running at normal speeds. It also occurs when the machine control sees output from the proximity sensor that implies the tumbler is still turning when the control has commanded it to Stop.
Action	When detected, there is a short delay before the error is active. When active, the control turns off the motor and all relays.
Exit	The machine will not start and the Error Code will continue to be displayed until the prompt is followed to Reset the Error Code and return the Machine to Idle Mode.
<b>CONTROL FIRMWARE XX</b>	
Condition	This error occurs when the Main Control Board cannot command the input and outputs of the control system as required by the cycle programming.
Action	When detected, the control turns off the motor and all relays. There is no delay in the action once the criteria are met.
Exit	The machine will not start and the Error Code will continue to be displayed until the prompt is followed to Reset the Error Code and return the Machine to Idle Mode. If the prompt to Reset is not available, power must be cycled to the machine to reset the error.
<b>CONTROL COMMUNICATION</b>	
Condition	This error occurs when the Main Control Board receives an unexpected command for the input and outputs of the control system as required by the cycle programming.
Action	When detected, the control turns off the motor and all relays. There is no delay in the action once the criteria are met.

Exit	The machine will not start and the Error Code will continue to be displayed until the prompt is followed to Reset the Error Code and return the Machine to Idle Mode. If the prompt to Reset is not available, power must be cycled to the machine to reset the error.
<b>GRAPHICS SOFTWARE</b>	
Condition	This error occurs when the Graphics Board cannot command the Main Control board as required by the cycle programming.
Action	When detected, the control turns off the motor and all relays. There is no delay in the action once the criteria are met.
Exit	The machine will not start and the Error Code will continue to be displayed until the prompt is followed to Reset the Error Code and return the Machine to Idle Mode. If the prompt to Reset is not available, power must be cycled to the machine to reset the error.
<b>GRAPHICS SOFTWARE INTERNAL</b>	
Condition	This error occurs when the Graphics Board sends a faulty command to the Main Control board.
Action	When detected, the control turns off the motor and all relays. There is no delay in the action once the criteria are met.
Exit	The machine will not start and the Error Code will continue to be displayed until the prompt is followed to Reset the Error Code and return the Machine to Idle Mode. If the prompt to Reset is not available, power must be cycled to the machine to reset the error.
<b>MODEL JUMPER MISSING</b>	
Condition	This error occurs when there is no connection to Ground (Pin 7) on the Model Jumper Header.
Action	When detected, the control turns off the motor and all relays. There is no delay in the action once the criteria are met. The machine control checks for this condition when power is cycled and before starting every machine cycle.
Exit	The machine will not start and the Error Code will continue to be displayed until the condition no longer exists and the prompt is followed to Reset the Error Code and return the Machine to Idle Mode.
<b>MODEL JUMPER CHANGED</b>	
Condition	This error occurs when the jumper connections to Ground (Pin 7) on the Model Jumper Header have changed since the last control check.
Action	When detected, the control turns off the motor and all relays. There is no delay in the action once the criteria are met. The machine control checks for this condition when power is cycled and before starting every machine cycle.
Exit	The machine will not start and the Error Code will continue to be displayed until the condition no longer exists and the prompt is followed to Reset the Error Code and return the Machine to Idle

	Mode.
<b>MODEL JUMPER/ DRIVE SIZE MISMATCH</b>	
Condition	This error occurs when the jumper connections to Ground (Pin 7) on the Model Jumper Header do not match the VFD size code.
Action	When detected, the control turns off the motor and the heating relay. There is no delay in the action once the criteria are met. The machine control checks for this condition when power is cycled.
Exit	The machine will not start and the Error Code will continue to be displayed until the condition no longer exists and the prompt is followed to Reset the Error Code and return the Machine to Idle Mode.
<b>MODEL JUMPER/ DRIVE PARAMETER</b>	
Condition	This error occurs when the jumper connections to Ground (Pin 7) on the Model Jumper Header do not match the VFD parameters being used.
Action	When detected, the control turns off the motor and the heating relay. There is no delay in the action once the criteria are met. The machine control checks for this condition when power is cycled.
Exit	The machine will not start and the Error Code will continue to be displayed until the condition no longer exists and the prompt is followed to Reset the Error Code and return the Machine to Idle Mode.
<b>NON-DEXTER DRIVE</b>	
Condition	This error occurs when a non-Dexter VFD is installed in the machine.
Action	When detected, the control turns off the motor and all relays. There is no delay in the action once the criteria are met. The machine control checks for this condition when power is cycled and before starting every machine cycle.
Exit	The machine will not start and the Error Code will continue to be displayed until the condition no longer exists and the prompt is followed to Reset the Error Code and return the Machine to Idle Mode.
<b>DRIVE OVERCURRENT</b>	
Condition	This error occurs when the control receives a message that the drive has experienced an over current condition.
Action	When detected, the control turns off the motor and all relays. There is no delay in the action once the criteria are met.
Exit	The machine will not start and the Error Code will continue to be displayed until the condition no longer exists and the prompt is followed to Reset the Error Code and return the Machine to Idle Mode.

<b>DRIVE OVERVOLTAGE</b>	
Condition	This error occurs when the control receives a message that the drive has experienced an over voltage condition.
Action	When detected, the control turns off the motor and all relays. There is no delay in the action once the criteria are met.
Exit	The machine will not start and the Error Code will continue to be displayed until the condition no longer exists and the prompt is followed to Reset the Error Code and return the Machine to Idle Mode.
<b>DRIVE OVERHEAT</b>	
Condition	This error occurs when the control receives a message that the drive has experienced an over heat condition.
Action	When detected, the control turns off the motor and all relays. There is no delay in the action once the criteria are met.
Exit	The machine will not start and the Error Code will continue to be displayed until the condition no longer exists and the prompt is followed to Reset the Error Code and return the Machine to Idle Mode.
<b>DRIVE OVERLOAD</b>	
Condition	This error occurs when the control receives a message that the drive has experienced an overload condition.
Action	When detected, the control turns off the motor and all relays. There is no delay in the action once the criteria are met.
Exit	The machine will not start and the Error Code will continue to be displayed until the condition no longer exists and the prompt is followed to Reset the Error Code and return the Machine to Idle Mode.
<b>DRIVE GROUND FAULT</b>	
Condition	This error occurs when the control receives a message that the drive has experienced a ground fault condition.
Action	When detected, the control turns off the motor and all relays. There is no delay in the action once the criteria are met.
Exit	The machine will not start and the Error Code will continue to be displayed until the condition no longer exists and the prompt is followed to Reset the Error Code and return the Machine to Idle Mode.
<b>DRIVE LOW VOLTAGE</b>	
Condition	This error occurs when the control receives a message that the drive has experienced a low voltage condition.
Action	When detected, the control turns off the motor and all relays. There is no delay in the action once the criteria are met.
Exit	The machine will not start and the Error Code will continue to be displayed until the condition no longer exists and the prompt is

	followed to Reset the Error Code and return the Machine to Idle Mode.
<b>DRIVE INTERNAL</b>	
Condition	This error occurs when the control receives a message that the drive has experienced an internal error.
Action	When detected, the control turns off the motor and all relays. There is no delay in the action once the criteria are met.
Exit	The machine will not start and the Error Code will continue to be displayed until the condition no longer exists and the prompt is followed to Reset the Error Code and return the Machine to Idle Mode.
<b>DRIVE EXCEPTION</b>	
Condition	This error occurs when the control receives a message that the drive has logged an exception code.
Action	When detected, the control turns off the motor and all relays. There is no delay in the action once the criteria are met.
Exit	The machine will not start and the Error Code will continue to be displayed until the condition no longer exists and the prompt is followed to Reset the Error Code and return the Machine to Idle Mode.
<b>DRIVE COMMUNICATION</b>	
Condition	This error occurs the control cannot communicate with the VFD.
Action	When detected, the control turns off the motor and all relays. There is no delay in the action once the criteria are met.
Exit	The machine will not start and the Error Code will continue to be displayed until the condition no longer exists and the prompt is followed to Reset the Error Code and return the Machine to Idle Mode.
<b>DRIVE ENABLE</b>	
Condition	This error occurs when the control sees a message that the VFD Enable circuit is not closed.
Action	When detected, the control turns off the motor and all relays. There is no delay in the action once the criteria are met.
Exit	The machine will not start and the Error Code will continue to be displayed until the condition no longer exists and the prompt is followed to Reset the Error Code and return the Machine to Idle Mode.
<b>DOOR SHUT, NOT LOCKED</b>	
Condition	This error occurs when the Door Locked signal is not received within 1 second after the start of the cycle.
Action	When detected, the control turns off the motor and all relays. There is no delay in the action once the criteria are met.
Exit	The machine will not start, and the Error Code will continue to be



	displayed until the prompt is followed to Reset the Error and return the machine to Idle mode.
<b>SLOW SPIN</b>	
Condition	This error occurs when the motor does not reach a target frequency while accelerating, within a specified time.
Action	When detected, the control turns off the motor and machine motion stops.
Exit	The machine will not start, and the Error Code will continue to be displayed until the prompt is followed to Reset the Error and return the machine to Idle mode.
<b>SPIN TIME</b>	
Condition	This error occurs when the motor does not reach a target frequency while decelerating, within a specified time.
Action	When detected, the control turns off the motor and machine motion stops.
Exit	The machine will not start, and the Error Code will continue to be displayed until the prompt is followed to Reset the Error and return the machine to Idle mode.
<b>SLOW FILL</b>	
Condition	This error occurs when the programmed water level is not reached within 7 minutes.
Action	When detected at 7 minutes into the stage, the control will display the "SLOW FILL ERROR" prompt, alternating with the normal Cycle Progress screen at a rate of 5 seconds on, 5 seconds off. Otherwise the cycle will continue normally. However, if the water level is still not met at 15 minutes into the stage, the cycle will end with the motor turned off and all relays turned off
Exit	The Error Code will continue to be displayed until the in-progress cycle is stopped and the control is returned to Idle Mode. It will then reset automatically.
<b>SLOW DRAIN</b>	
Condition	This error occurs when an empty water level is not reached within 5 minutes.
Action	When detected at 5 minutes from the beginning of the drain operation, the prompt "SLOW DRAIN ERROR" is displayed. The washing cycle continues, but the spin portion of the cycle will not occur. It is replaced by continued tumble until the cycle time is expired. If low water level is detected during spin, the control turns off the motor and all relays with no delay in action.
Exit	The machine will not start and the Error Code will continue to be displayed until the condition no longer exists and the prompt is followed to Reset the Error Code and return the Machine to Idle Mode.

<b>EXCESSIVE VIBRATION</b>	
Condition	This error occurs when excessive vibration is detected or the out of balance circuit from the VFD to the main control board is compromised.
Action	When detected, the control turns off the motor and all relays. There is no delay in the action once the criteria are met.
Exit	The machine will not start and the Error Code will continue to be displayed until the condition no longer exists and the prompt is followed to Reset the Error Code in the General Settings section and return the Machine to Idle Mode. The maximum displacement switch may also need to be reset.
<b>PRESSURE OUT OF RANGE HIGH</b>	
Condition	This error occurs when the pressure sensing voltage is higher than expected.
Action	When detected, the control turns off the motor and all relays. There is no delay in the action once the criteria are met.
Exit	The machine will not start and the Error Code will continue to be displayed until the condition no longer exists and the prompt is followed to Reset the Error Code and return the Machine to Idle Mode.
<b>PRESSURE OUT OF RANGE LOW</b>	
Condition	This error occurs when the pressure sensing voltage is lower than expected.
Action	When detected, the control turns off the motor and all relays. There is no delay in the action once the criteria are met.
Exit	The machine will not start and the Error Code will continue to be displayed until the condition no longer exists and the prompt is followed to Reset the Error Code and return the Machine to Idle Mode.
<b>OUT OF BALANCE LOAD</b>	
Condition	This error occurs when the load in the machine exceeds the out of balance conditions for achieving spin speeds.
Action	If detected, the machine will attempt to redistribute the load by tumbling. During any intermediate spin, the machine will attempt to redistribute the load 1 time before advancing to the next stage. During final spin, the machine will attempt up to 3 redistributions before the final de-clumping occurs.
Exit	No user input is required to clear this error condition.

<b>OUT OF SERVICE</b>	
Condition	This error occurs when the user has designated that the machine control should be made inoperable.
Action	When detected, the control turns off the motor and all relays. There is no delay in the action once the criteria are met.
Exit	The machine will not start, and the Error Code will continue to be displayed the user changes the Out of Service state.

Note: Whenever power is turned off to the washer, it **must** remain off for one minute. The washer will not operate properly if this is not done.

## 6 TROUBLESHOOTING – REVIEW FOR NEEDED CHANGES

**CAUTION:** Label all wires prior to disconnection when servicing controls. Wiring errors can cause improper and dangerous operation. Verify proper operation after servicing.

**ATTENTION:** Lors des opérations d'entretien des commandes, étiqueter tous les fils avant de les déconnecter. Toute erreur de câblage peut être une source de danger et de panne.

If any of the following symptoms occur on this washer, check the suggested remedies listed below. If all probable causes have been eliminated and the symptom still exists, contact your local Dexter agent for further troubleshooting assistance. See contact information at the end of this manual. Parts & Service Manuals from Dexter are also available for further troubleshooting assistance.

Symptom	Probable Cause	Suggested Remedy
<b>Machine does not start</b>	Power Supply	Check these areas: Circuit breakers, Voltage, Power leads, Power connections. Is front display lit?
	Door Switch	Check for continuity through door switch when door is closed. If no continuity, adjust or replace door switch.
	Fuses or circuit breaker	Check the 1.5 amp and 2.0 amp fuses (60 hz models) or circuit breaker (50 hz models) for continuity. If no continuity, replace fuse or breaker.
	Control Transformer	Check voltage output from control transformer for 24 VAC and 120VAC (50 hz models have 24 VAC only). If voltage is incorrect, check for proper transformer tap connection or replace transformer.
	Check PCB boards	Check all wire connections for sure contacts.
	Check wiring between PCB and VFD	Check data cable phone type connectors: unplug and re-plug with power removed.
	Check Door Lock Mechanism	Check that 120 VAC power (for 60 hz) or 24 VAC power (for 50 hz) is at door lock motor after start button is pressed.
<b>Door does not lock</b>	Check display for message	Follow tests described in fault code section.
	Door locking mechanism	Check to ensure that mechanism is receiving 12VDC from main relay PCB. If it is receiving power but not functioning, then replace mechanism.
	Door Closed Switch	Check for continuity when door closed. If no continuity, replace door switch.

<b>Door will not open</b>	Door locking mechanism	
<b>No hot water in detergent dispenser</b>	Water Valve Coil	Check coil continuity at terminals and replace if no continuity. 120 VAC power (60Hz) only on for 20 second in wash bath. (24 VAC for 50 Hz models)
	Water Inlet	Check water inlet screens for blockage and clean screens if necessary.
	Water	Check to ensure that water is turned on and operating.
	Wire Harness	Check wire harness to valve.
<b>Hot water does not enter tub in wash</b>	Water Valve Coil	Check coil continuity at terminals and replace if no continuity. Check for 120 VAC power (60 Hz) from main relay PCB. (24 VAC for 50 Hz models)
	Water Inlet	Check water inlet screens for blockage and clean if necessary.
	Water	Check to ensure that water is turned on and operating.
	Check Voltage	If appropriate voltage is not present at the valve, refer to the wiring diagram for your specific washer model. Check for voltage at the P4 Connector on the Relay PCB. Check for LED indication that the appropriate relay is activated.
	Pressure Switch	Check the green 1V, 1.5V, or 2V indicator LEDs on the pressure switch. Depending on the size and water fill level of the machine, these LEDs will turn on as the water level increases. If water level is empty, no LEDs should be on.
<b>No cold water to tub in wash</b>	Water Valve Coil	Check coil continuity at terminals and replace if no continuity.
	Water Inlet Screens	Check water inlet screens for blockage and clean if necessary.
	Water	Check to ensure that water is turned on and operating.
	Check Voltage	If appropriate voltage is not present at the valve, refer to the wiring diagram for your specific washer model. Check for voltage at the P4 Connector on the Relay PCB. Check for LED indication that the appropriate relay is activated.
	Pressure Switch	Check the green 1V, 1.5V, or 2V indicator LEDs on the pressure switch. Depending on

		the size and water fill level of the machine, these LEDs will turn on as the water level increases. If water level is empty, no LEDs should be on.
<b>Water comes in but level does not rise</b>	Drain Valve (open)	Check these areas: <ul style="list-style-type: none"> <li>• Drain valve blockage</li> <li>• Drain valve motor and gear train. If power but drain valve does not close, replace valve.</li> <li>• Power to the drain valve. If no power to drain valve, check circuit for power.</li> </ul>
	Check Voltage	If appropriate voltage is not present at the valve, refer to the wiring diagram for your specific washer model. Check for voltage at the P4 Connector on the Relay PCB. Check for LED indication that the appropriate relay is activated.
<b>Water does not flush softener compartment</b>	Water Valve Coil	Check coil continuity at terminals and replace if no continuity.
	Water Inlet Screens	Check water inlet screens for blockage and clean if necessary.
	Water	Check to ensure that water is turned on and operating.
<b>Water does not flush softener compartment</b>	Pressure Switch	Check the green 1V, 1.5V, or 2V indicator LEDs on the pressure switch. Depending on the size and water fill level of the machine, these LEDs will turn on as the water level increases. If water level is empty, no LEDs should be on.
<b>Water level too high</b>	Pressure Switch	Check the green 1V, 1.5V, or 2V indicator LEDs on the pressure switch. Depending on the size and water fill level of the machine, these LEDs will turn on as the water level increases. If water level is empty, no LEDs should be on.
<b>Water drains slowly</b>	Drain System	Check hoses and drain valve for blockage. Check if inadequate size. If necessary, check building drains for blockage.
<b>Machine does not turn</b>	VFD	Review indicator lights displayed on VFD. See VFD indicator section for more info. If no display, turn power off to machine at breaker for 2 minutes and turn power back on to reset. If still no display, replace VFD.
<b>Machine tumbles in one direction</b>	VFD	Review indicator lights displayed on VFD. See VFD indicator section for more info.
		Inspect yellow enable wires from main relay PCB and at VFD.

<b>Excessive vibration</b>	Flooring	Check the strength of flooring or mounting base (if used).
	Drive Belt	Worn drive belt can cause vibration and noise.
	Out Of Balance Circuit	Check for an open circuit in the wiring between the VFD and the J8 connector on the main control board.
	Suspension	Check the springs and dampers for wear.
<b>Machine does not spin</b>	Pressure Switch	Check the green 1V, 1.5V, or 2V indicator LEDs on the pressure switch. Depending on the size and water fill level of the machine, these LEDs will turn on as the water level increases. If water level is empty, no LEDs should be on.
<b>Machine starts and does not operate</b>	VFD	Check for Error codes- Refer to individual Error code descriptions.
<b>Machine does not stop</b>	Main PCB	Main PCB controls time cycle at end of cycle
	Braking Resistors	Check braking resistors for continuity. Verify ohms resistance.
<b>Water leakage around loading door</b>	Door Adjustment	Door may need adjustment due to abuse or wear. Check tightness around perimeter using a dollar bill. Adjust left to right tightness by shims at door lock or hinge side. It is important to center gasket to tub opening before tightening door to hinge bolts. Chalk may be used on tub front to show point of contact with tub. If gasket is deformed, worn, or damaged, replace. Refer to parts section for door gasket expander kit.

## **7 TRANSIENT VOLTAGE SURGE SUPPRESSORS**

### **IMPORTANT**

Like most electrical equipment your new machine can be damaged or have its life shortened by voltage surges due to lightning strikes which are not covered by factory warranty. Local power distribution problems also can be detrimental to the life of electrical components. We recommend the installation of transient voltage surge suppressors for your new equipment. These devices may be placed at the power supply panel for the complete installation and don't require an individual device for each machine.

These surge protectors help to protect equipment from large spikes and also from small ongoing spikes in the power that occur on a day to day basis. These smaller surges can shorten overall life of electrical components of all types and cause their failure at a later date. Although they can't protect against all events, these protective devices have a good reputation for significantly lengthening the useful life of electronic components.

Electronic components are helped to have a longer useful life when they are supplied with the clean stable electrical power they like.

We are including the following names and website links of a few suppliers of these devices for those who don't currently have a source.

#### MANUFACTURER

#### LINK

MCG Surge Protection

[mcgsurge.com](http://mcgsurge.com)

Eaton Corporation

[eaton.com/us/en-us](http://eaton.com/us/en-us)

Schneider Electric

[se.com/us/en](http://se.com/us/en)

Asco Power Technologies

[ascopower.com/us/en](http://ascopower.com/us/en)

Emerson Electric Co.

[emerson.com/en-us](http://emerson.com/en-us)



## 8 SERVICE AND PARTS

The following parts are provided with each machine for use in installation.

For S-675

<u>Dexter Part Number</u>	<u>Description</u>	<u>Quantity</u>
9990-027-011 (60Hz)	Hose, Water Supply	2
9990-024-015 (50Hz)	Hose, Water Supply (Red end)	1
9990-024-016 (50Hz)	Hose, Water Supply (Blue end)	1
8641-242-000 (All)	Washer, Inlet Hose	2
9565-003-001 (All)	Strainer, Inlet Hose	2

For S-975

<u>Dexter Part Number</u>	<u>Description</u>	<u>Quantity</u>
9990-027-011 (60Hz)	Hose, Water Supply	2
9990-027-013 (60Hz)	Hose, Water Supply (Large)	2
9990-024-015 (50Hz)	Hose, Water Supply (Red end)	1
9990-024-016 (50Hz)	Hose, Water Supply (Blue end)	1
9990-024-017 (50Hz)	Hose, Water Supply (Red end-Large)	1
9990-024-018 (50Hz)	Hose, Water Supply (Blue end-Large)	1
8641-242-000 (All)	Washer, Inlet Hose	4
9565-003-001 (All)	Strainer, Inlet Hose	4

Contact distributor or Dexter Laundry, Inc. if a steel-mounting base or leveling legs are required.

For service and parts information, contact your local Dexter agent. To find your local Dexter agent, use the Distributor Locator at the website shown below. If a Dexter agent is not available, contact **Dexter Laundry, Inc.** directly as listed below:

Mailing Address: 2211 West Grimes Avenue Phone: 1-800-524-2954  
Fairfield, IA 52556  
USA

Website: [www.dexter.com](http://www.dexter.com)