

SERIES







**X-Series Series Vended Standard Chassis Washers
Express (200G) & Non-Express (100G) Service Manual**



DEXTER[®]
LAUNDRY

Equipment Safety Warnings Symbols and Terminology Used in this Equipment

⚠ DANGER	Indicates an imminently hazardous situation, which if not avoided, will result in death or serious injury.
⚠ WARNING	Indicates a potentially hazardous situation, which if not avoided could result in death or serious injury.
⚠ CAUTION	Indicates a potentially hazardous situation which, if not avoided, may result in minor or moderate injury. It may also be used to alert against unsafe practices. Minor burns, pinch points that result in bruises and minor chemical irritation.
NOTICE	Indicates information or a company policy that relates directly or indirectly to the safety of personnel or protection of property.
	This is the user caution symbol. It indicates a condition where damage to the equipment resulting in injury to the operator could occur if operational procedures are not followed. TO REDUCE THE RISK OF DAMAGE OR INJURY, refer to accompanying documents; follow all steps or procedures as instructed.
	This is the electrical hazard symbol. It indicates that there are DANGEROUS HIGH VOLTAGES PRESENT inside the enclosure of this product. TO REDUCE THE RISK OF FIRE OR ELECTRIC SHOCK, do not attempt to open the enclosure or gain access to areas where you are not instructed to do so. REFER SERVICING TO QUALIFIED SERVICE PERSONEL ONLY
	Caution! There are sharp edges on various sheet metal parts internal to the enclosure. Use safety consciousness when placing or moving your hands while working in the interior of this equipment.
	Caution! To reduce the risk of damage to the Water Inlet Valve, do not supply inlet water with a temperature that exceeds 70° C. Caution! To reduce the risk of fire or explosion, do not operate this equipment in any hazardous classified (ATEX) environment.

Equipment Safety Warnings Symbols and Terminology Used in this Equipment



Warning! Do not operate equipment if door glass is damaged in any way.



Warning! Keep clear of rotating parts.



Prohibited! Do not enter this equipment or space.



Prohibited! Do not step or stand on this equipment.



Prohibited! Do not operate without all guards and covers in place.









Prohibited! Do not operate without all guards and covers in place.









Prohibited! Do not wash clothing impregnated with flammable liquids (petrochemical).



Prohibited! Do not allow children to play in or around equipment.

	Indicates an imminently hazardous situation, which if not avoided, will result in death or serious injury.
	Indicates a potentially hazardous situation, which if not avoided could result in death or serious injury.
	Indicates a potentially hazardous situation which, if not avoided, may result in minor or moderate injury. It may also be used to alert against unsafe practices. Minor burns, pinch points that result in bruises and minor chemical irritation.
	Indicates information or a company policy that relates directly or indirectly to the safety of personnel or protection of property.
	This is the user caution symbol. It indicates a condition where damage to the equipment resulting in injury to the operator could occur if operational procedures are not followed. TO REDUCE THE RISK OF DAMAGE OR INJURY, refer to accompanying documents; follow all steps or procedures as instructed.
	This is the electrical hazard symbol. It indicates that there are DANGEROUS HIGH VOLTAGES PRESENT inside the enclosure of this product. TO REDUCE THE RISK OF FIRE OR ELECTRIC SHOCK, do not attempt to open the enclosure or gain access to areas where you are not instructed to do so. REFER SERVICING TO QUALIFIED SERVICE PERSONEL ONLY
	Caution! To reduce the risk of fire or explosion, do not operate this equipment in any hazardous classified (ATEX) environment.

 WARNING	
	<ul style="list-style-type: none"> • All washers must be installed in accordance to all applicable electrical, plumbing and all other local codes. • These installation and operation instructions are for use by qualified personnel only. To avoid injury and electrical shock, do not perform any servicing other than that contained in the installation and operation instructions, unless qualified.
	Do not install washers in an explosive atmosphere.
	<ul style="list-style-type: none"> • Care must be stressed with all foundation work to ensure a stable unit installation, eliminating possibilities of excessive vibration. • Foundation must be level within 13 mm to ensure proper washer operation.
	Do not operate washer if door glass is damaged in any way.
	Do not wash clothing impregnated with flammable liquids (petrochemical).



WARNING







	Children should be supervised to ensure they do not operate or play in or around equipment.
	Keep all panels in place to protect against electrical shock and injury and add rigidity to washer.

This appliance is not intended for use by persons (including children) with reduced physical, sensory or mental capabilities, or lack of experience and knowledge, unless they have been given supervision or instruction concerning use of the appliance by a person responsible for their safety.

A washer should not be allowed to operate if any of the following occur:

- Excessive high water level.
- Machine is not connected to a properly earthed circuit.
- Door does not remain securely locked during the entire cycle.
- Vibration or shaking from an inadequate mounting or foundation

	Warning! Do not operate equipment if door glass is damaged in any way.
	Warning! Keep clear of rotating parts.
	Prohibited! Do not enter this equipment or space.
	Prohibited! Do not step or stand on this equipment.
	Prohibited! Do not operate without all guards and covers in place.
	Prohibited! Do not operate without all guards and covers in place.
	Prohibited! Do not wash clothing impregnated with flammable liquids (petrochemical).
	Prohibited! Do not allow children to play in or around equipment.

	Prohibited! Do not attempt to open, touch, or proceed before referring to the manual or unless qualified.
	Mandatory! Read all supporting documentation before operating or maintaining equipment.
	Mandatory! Disconnect power before servicing equipment.
	Mandatory! Lock out and tag out before servicing this equipment.
	Mandatory! Disconnect water supply before servicing equipment.
	Mandatory! Children should be supervised to ensure they do not operate equipment.

Dexter Safety Guidelines



These washers are equipped with devices and features relating to their safe operation. To avoid injury or electrical shock, do not perform and service, unless qualified to do so.

FOR SAFETY

1. Always shut off power and water supply and also discharge capacitors before servicing.
2. Do not overload the washer.
3. Do not attempt to open door if cylinder is in motion or contains water.
4. Do not mechanically force or override door lock in any way.
5. Do not bypass any safety devices of this washer.
6. Do not use volatile or flammable substances in or near this washer.
7. Keep all panels in place. They protect against shock and injury and add rigidity to the washer.

A machine should not be allowed to operated if any of the following occur:

- Excessively high water level.
- Machine is not connected to a properly grounded circuit.
- Loading door does not remain securely locked during the entire cycle.
- Vibration or shaking from an inadequate mounting or foundation.

To activate your warranty, be sure to return your red warranty form to the factory. Please have serial number and model ready when calling for assistance.

Other Technical Documents for Touch Series Vended Washers:



INSTALL, MOUNTING, & OPERATION

This information is available in the Operators Manual linked here: [Operator's Manual](#)



PROGRAMMING

Programming information available in the Programming Guide linked here: [Programming Guide](#)



TROUBLESHOOTING

Troubleshooting & Error Codes information available in the Troubleshooting Guide linked here: [Troubleshooting Guide](#)



MAINTENANCE

Preventative Maintenance information available in the Maintenance Guide linked here: [Maintenance Guide](#)



60HZ WIRING DOCUMENTS

This information is available on [Dexter.com/support/technical-information](#) and also linked below:

[T-350](#)
[T-450](#)
[T-650](#)
[T-950](#)
[T-1450](#)
[T-1800](#)

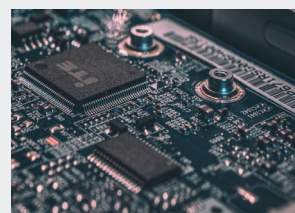

50HZ WIRING DOCUMENTS

This information is available on [Dexter.com/support/technical-information](#) and also linked below:

[T-350](#)
[T-450](#)
[T-650](#)
[T-950](#)
[T-1450](#)
[T-1800](#)



SPECIFICATION SHEETS

This information is available on [Dexter.com/support/technical-information](#) and also linked below:

[T-350](#)
[T-450](#)
[T-650](#)
[T-950](#)
[T-1450](#)
[T-1800](#)



PARTS DATA

This information will be available on [Dexter.com/support/technical-information](#) for the following models coming soon:

T-350
T-450
T-650
T-950
T-1450
T-1800

Table of Contents

Section 1:

Machine Service Procedures

Top Panel Removal.....	13
Front Panel Removal	13
Back Panel Removal.....	13
Control Panel Name Plate Decal	13
Name Plate Removal	13
Re-Installation of Name Plate.....	13
Touch Screen Protector Removal & Install	13
Detergent Dispenser	14
Vacuum Breaker/Air Gap	15
Water Valves	15
Drain Valve Access	15
Drain Valve Cleaning	15
Door Lock Assembly Operation	16
Adjustment for the Door Lock Assembly	16 & 17
Adjusting the Loading Door	18
Loading Door Removal	18
Loading Door Hinge Removal.....	18
Loading Door Disassembly	19
Loading Door Reassembly	19
Door Locking Gear Motor Assembly	19
Thermoactuators	19
Lock Thermoactuator	19
Unlock Thermoactuator	19
Drive Motor Removal.....	20
Drive Belt Removal.....	20
Outer Cabinet Removal	21
Tub Back, Bearing and Cylinder Assembly	22
Basket Pulley, Bearing Housing, Water Seals & Tub Back	23-24
Tub Back, Bearing and Cylinder Assembly - Large Chassis	25
Basket Pulley, Bearing Housing, Water Seals & Tub Back Large Chassis	26-27
Bolt Torque Charts	28-29

Section 2:

Service Electrical Components

Control Mounting Trough.....	31
Main Data Communication Cable.....	31
Fuse.....	31
Controls Transformer.....	31
Touch Screen Display Assembly	31
Main Relay Printed Circuit Board	31
Emergency Stop Button & Switch Assembly.....	31
Power Connection Terminal Block	31
Delta Variable Frequency Drive	32
Delta VFD Motor Leads.....	32
Delta VFD Dynamic Braking	
Resistors	32
Delta VFD Cooling Fan	32

Section 3:

Machine Electrical & Wiring Schematics

Start Circuit	34
Agitation Circuit	35
Warm Fill Circuit.....	35
Wash Circuit	35
Final Rinse Circuit	35
Spin & Extract Circuit	36
Thermoactuator and Shake Out Circuit.....	36
End of Cycle Circuit.....	36
Motor Resistance Charts.....	37

USE THE TABS LOCATED ON THE RIGHT SIDE OF THE DOCUMENT TO ADVANCE TO EACH SECTION.

Section 1:

Machine Service Procedures

Top Panel Removal

Step 1: Remove 4 screws that hold detergent dispenser to top panel. If front soap dish, go to step 2.

Step 2: Unlock top panel lock with the 6324 key.

Step 3: Raise top panel, slide to the rear to release from back clips and lift off.

Front Panel Removal

Step 1: Remove the loading door by first removing the two lower screws of the lower hinge clamp and lifting the door off of the hinge assembly.

Step 2: Remove 2 screws between front panel top and front (located behind control panel).

Step 3: Remove the two screws in the middle of the front panel.

Step 4: Pull panel out at the bottom to about a 45 degree angle to detach the top lip and remove.

Back Panel Removal

Step 1: Remove all screws holding back panel in position except the bottom row.

Step 2: The bottom row of screws are slotted and only need to be loosened and to lift off panel.

Note: The back panel is not only a safety requirement but also contributes to the rigidity of the cabinet.

Control Panel Name Plate Decal

The name plate on washer front is adhesive backed.

Control Panel Name Plate Removal

The name plate may be removed by simply peeling it off.

Re-Installation of Name Plate

Step 1: Remove any remaining glue from the control panel.

Step 2: Before removing the paper backing from the name plate, check fit to the control panel. The program push buttons are the locating guides.

Step 3: Remove the paper backing from the right side of the name plate, position it on the panel and press right end into place. Peel the backing from the left end and press into place.

Touch Screen Protector Removal & Install

Step 1: Remove the top panel following the Top Panel Removal procedure above.

Step 2: Remove four nuts around the touch screen display assembly.

Step 3: Remove the touch screen display assembly to access the screen protector and remove protector.

Step 4: Follow steps in reverse to install. Remove film from back side of new screen protector before install.

Detergent Dispenser - Top Soap Dish Removal

Remove top panel to access dispenser. (see Removing Top Panel) Detergent is flushed from the front of the compartment and fabric softener is flushed from the back. There will be a small amount of water left in the fabric softener compartment after each use.

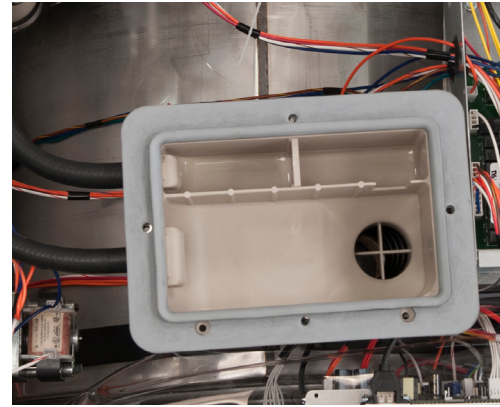

Front Soap Box Removal

- Step 1:** Remove front Panel
- Step 2:** Remove the six 3/8 nuts and remove Soap Box mounting bracket and Soap Box, followed by removing gasket.
- Step 3:** Reassemble reverse operation.

Note: Be sure to note position of washers and spacers behind mounting bracket.

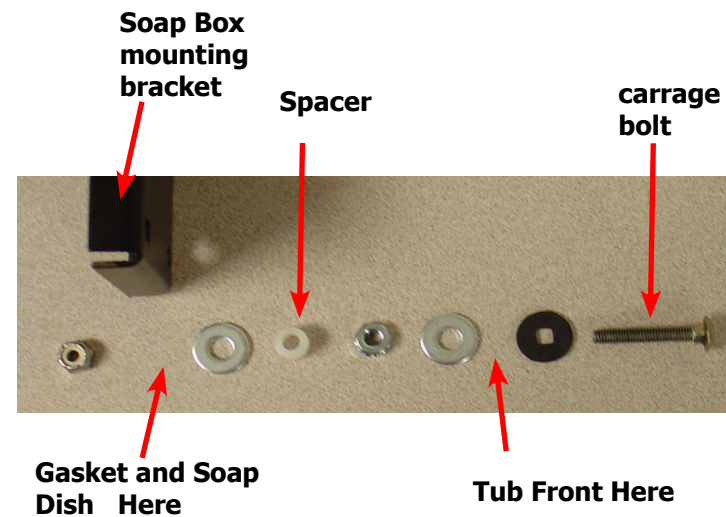

Vacuum Breaker (also called an air gap)

In the left rear of the cabinet is the vacuum breaker. It guides the water to the tub and dispenser and prevents a back flow of water.

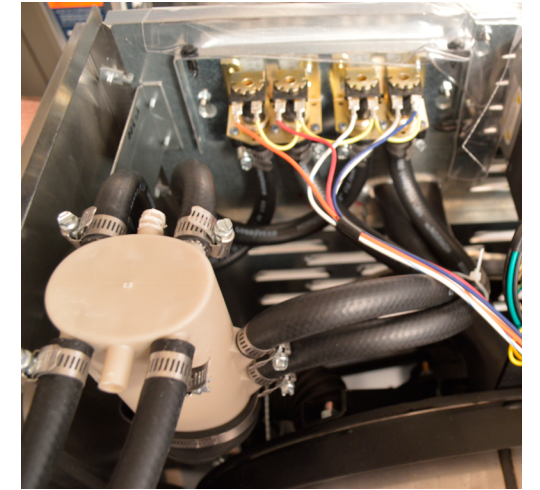

Water Valves

Remove top panel to access water valves. (see Removing Top Panel) The two dual outlet water valves are mounted to the water valve mounting plate that is fastened to the rear channel. To remove the valves, loosen the 2 locking nuts on both sides of the mounting plate from the interior of the machine and then lift the plate and valves off of the back channel and pull the assembly into the machine. The valves can then be removed from the mounting plate by removing the 5/16 mounting screws.

Always check inlet screens to be sure that they are clean. Disassembly requires the removal of two solenoid screws and three valve body screws. Below the solenoid coil is a solenoid guide, armature, armature spring and diaphragm. All valve parts are available individually or as a complete unit.

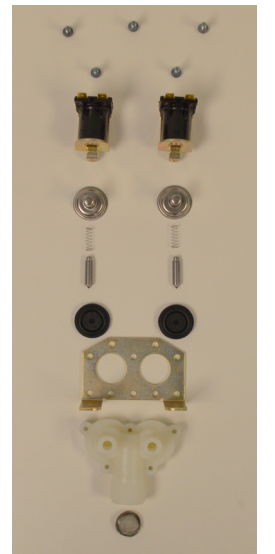

Drain Valve Access

For access to drain valve, remove lower service panel. The drain valve is a ball type and is powered closed by the drain valve motor. It is mounted under the washer tub on the left side. It is spring loaded open. If power is interrupted to the washer, the motor releases the sealing ball, allowing the drive spring to open the valve. With the valve open, all water in the washer will drain out.

Drain Valve Cleaning

- Step 1:** Loosen the clamp on the tub hose at the drain valve end and remove the hose from the drain valve.
- Step 2:** Loosen the drain hose clamp on the back of the drain valve. Remove two drain valve mounting racket screws from the frame of the washer.
- Step 3:** **Disconnect red & black wire connection at clear connector.**
- Step 4:** Remove the drain valve and bracket assembly. Unplug the wiring after the drain valve is removed from the washer.



Door Lock Assembly Operation

After loading the clothing, the door should be closed and latched. The locking cam on the door contacts the latching switch actuator which closes the latching switch. The specified number of coins should now be added to start the washer. The solenoid pulls up on the locking pawl by use of a linkage rod. The locking pawl has two jobs. The first is to lock the door. This is accomplished by blocking the locking cam on the door so that it can't rotate to unlock. The second job is to close the two piggyback lock sensing switches. These switches control power to all of the controls. If the door unlocks for any reason, these two switches will stop the machine. When the door handle is 1/4 to 1/2 of an inch from its fully closed position, the latching switch should close. The two piggyback lock sensing switches should be open when the door is unlocked and should be closed when the door is locked.

Accessing the Door Lock Assembly

After removing the front panel and masking ring, the door lock assembly can now be accessed.

Adjustment for Door Lock Assembly

The latching switch and the piggyback lock sensing switches all have slotted mounting for easy adjustment.

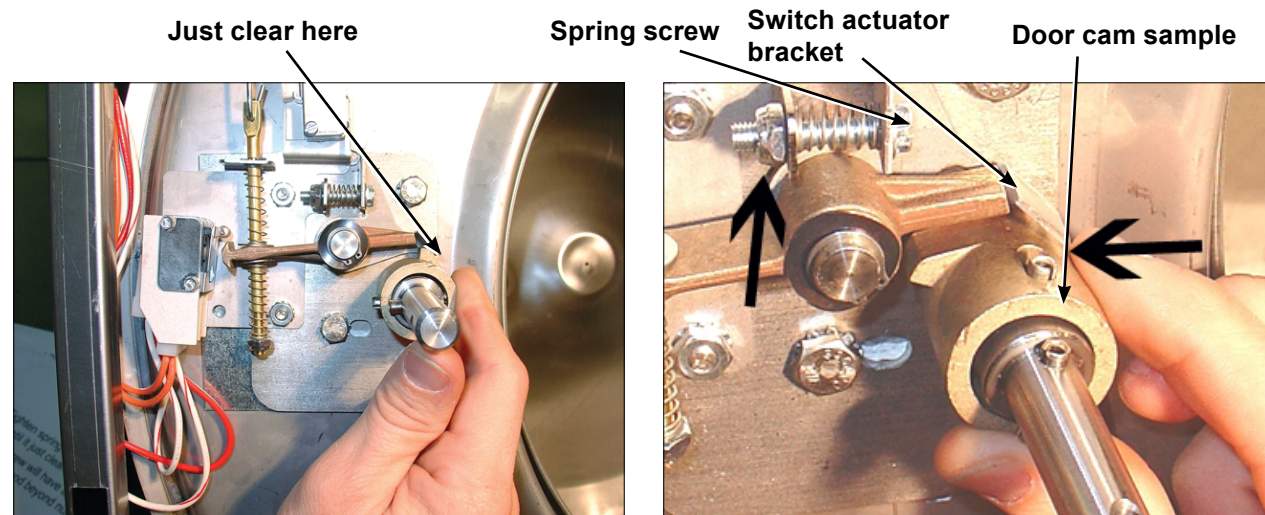

Step 2: Tighten spring screw on switch actuator bracket arm until it just clears cam OD. at base of door lock assembly.

Adjustment to this bracket usually is not necessary as next step is used more in field.

Flat blade screw on door switch latching

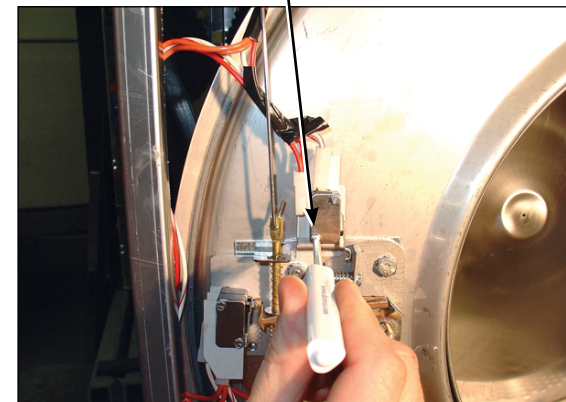

Step 3: With switch actuator bracket adjusted you will now need to adjust single switch by loosening 2 flat brade screws and allowing swivel of switch. Move switch towards above bracket until it actuates. Now tighten flat blade screws. Use a .040 thickness guage to insert between bracket and switch and the switch should close and open again upon removal of thickness guage.

Door cam check position

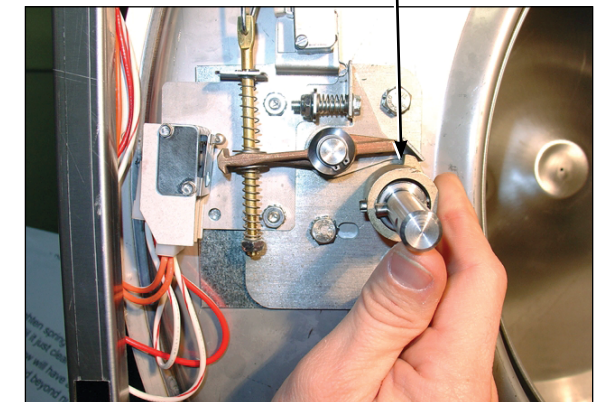

Step 4: Check for switch actuation at partial turn of cam as in operation above. Door handle goes from horizontal to six o'clock vertical.

Door lock rod Locking pawl blocking

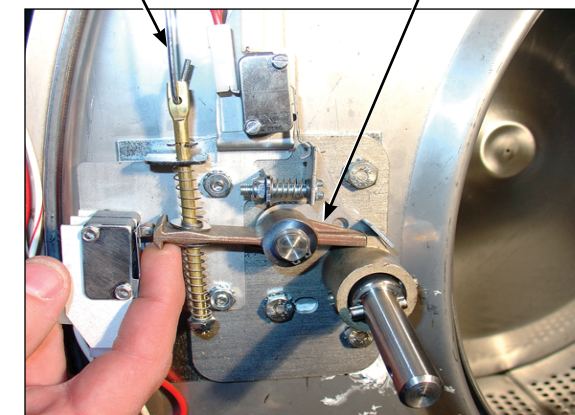

Step 5: Check that lock pawl arm swings to cam lobe to lock position.

Adjustment screw for (piggyback switches)

Top flat end of locking pawl.

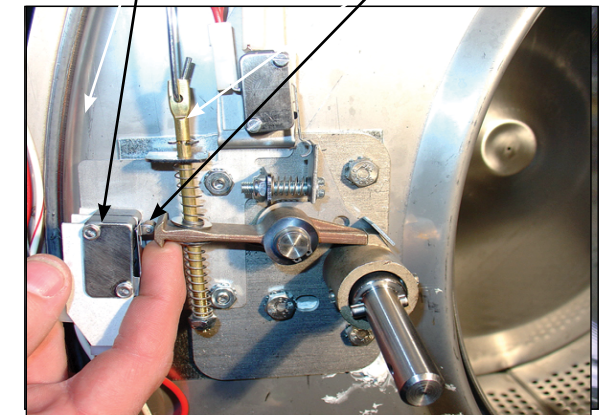

Step 6: The lock stacked switches (piggyback) must be adjusted as door lock solenoid pulls up on door rod and locking pawl is now blocking door cam from turning and is in full up position. The stacked switches (piggyback) have a single actuator arm and it must actuate when single actuator roller wheel rolls to flat side of locking pawl. You will also notice a .040 gap between actuator arm and switch bodies.

Note: Both stacked switches must operate together!

Adjusting the Loading Door

The door can be adjusted by changing the number of shims behind the door hinge and the door lock assembly. The vertical fit of the door to the tub can be altered by loosening the door hinge bolts and raising or lowering the door before retightening. It is important for the door to be centered on the tub front. By chalking the front of the tub and closing the door to transfer that line to the gasket, the centering can be evaluated. It is also important for door pressure to be similar around the door perimeter. Door pressure can be evaluated by inserting a dollar bill in several positions and tugging on it. See Parts Section for kit to increase door sealing pressure.

Loading Door Removal



Step 1: Support door to prevent dropping.



Step 2: Remove the bottom 2 bolts holding the lower leaf hinge and then remove it. The door can now be lifted from the upper post of the hinge assembly.

Loading Door Hinge Removal

Step 1: First remove loading door and front panel.

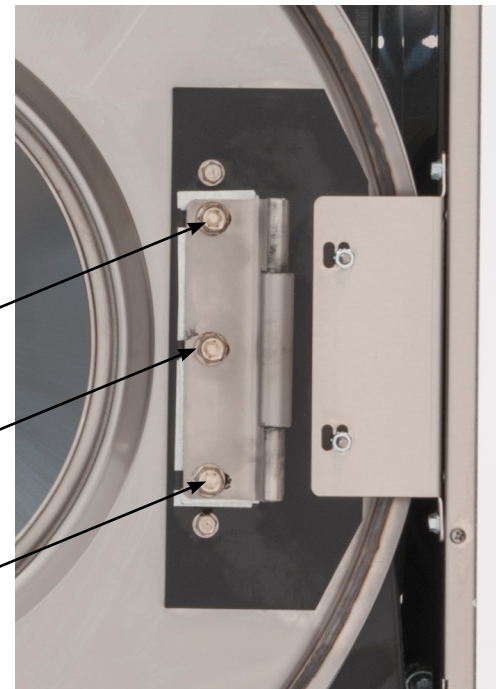

Step 2: Remove 3 screws holding door hinge. Shims may be present between hinge and tub front. The number may be increased or decreased to adjust right side door pressure.

NOTE: Door hinge mounting bolts penetrate tub front and require silicone sealer applied to holes when reinstalling.

Loading Door Disassembly

Step 1: Remove the loading door as outlined above. Lay the door on a flat surface with the glass down.

Step 2: While holding down on the door glass, lift up on the door ring and roll back the lip of the gasket with your fingers.

Step 3: Work all the way around the gasket and the glass is out.

Loading Door Reassembly

Step 1: Lay the door ring face down on a flat surface. Start the glass into one side of the door gasket.

Step 2: Use one hand underneath to push the gasket out and the other hand on the top pulling the gasket in place.

Step 3: The front lip of the door gasket should be checked for proper seating.

Door Locking Gear Motor Assembly

The door locking gear motor is rotated shut with control voltage to lock the door and releases when voltage is removed. It is located in the left front corner of the washer.

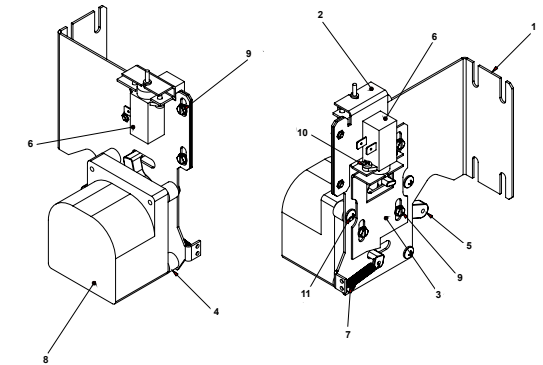

Door Lock Gear Motor

Thermoactuators

The thermoactuators are a safety device that keeps the door from immediately unlocking if power is lost while the machine is operating. They are mounted under the door locking solenoid.

Lock Thermoactuator

Control voltage is applied to the lock thermoactuator at the beginning of the cycle making it extend and block the door locking gear motor. This keeps the door locked for approximately two minutes after a power failure occurs. The lock thermoactuator does not delay the door opening at the end of a normal cycle.

Unlock Thermoactuator

To insure that the lock thermoactuator has retracted by the end of the cycle, one minute prior to the end of the cycle, the unlock thermoactuator is powered with control voltage making it extend and unblock the door locking gear motor.

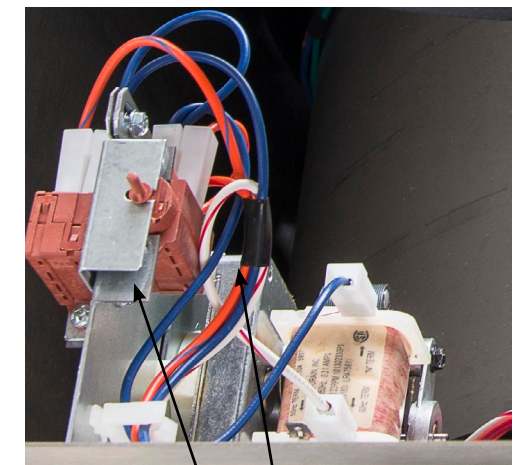

Thermoactuators

Drive Motor Removal

- Step 1:** Remove the drive belt as explained in instructions below.
- Step 2:** Remove the tension spring and bracket.
- Step 3:** Disconnect the motor wires at the variable frequency drive unit. The motor wire retaining clamp should be removed and reused. It is good to notate the location of the T1, T2, and T3. (It is normal in most cases that the T1 and T2 wires are swapped at the variable frequency drive.)
- Step 4:** Loosen the set screws on the motor support shaft.
- Step 5:** Remove the retaining bolt from the front of the support shaft.
- Step 6:** Remove the motor support shaft.
- Step 7:** Lift motor out of machine. Note: On larger washers it is advisable to put a board under the motor and slide it out rather than lifting it.

Drive Belt Removal

Turn the drive pulley while applying pressure to the drive belt until it rolls off of the basket pulley first and then remove from the motor pulley. Be cautious not to drop the motor which could unhook the tension assembly.

Reverse this procedure for installation.



Drive Belt

Outer Cabinet Removal

Removal of Cabinet

- Step 1:** The power supply, water hoses, and drain connection must all be disconnected before proceeding with the disassembly.
- Step 2:** Now remove the lower service panel and the top panel assembly.
- Step 3:** Remove the left and right lower front panel screws that retain the panel to the chassis.
- Step 3:** Remove the bottom row of back panel screws.
- Step 4:** Remove the loading door.
- Step 5:** Remove the four 7/16 nuts along the bottom of each side panel straps. When reinstalling these screws do not overtighten.
- Step 6:** If washer with top soap dish, remove clamp and soap dispenser hose where it attaches to the tub inlet. If washer has front soap box skip to Step 7.
- Step 7:** Disconnect the door lock wires from all switches and the door lock solenoid. Disconnect pull rod between solenoid and door lock assembly. Disconnect the wires to the dump valve at the bottom of the machine.
- Step 8:** Disconnect the wires to the drive motor from the VFD T1, T2, T3.
- Step 9:** Remove the clamp and the hose from the vacuum breaker where it connects to the inlet on the back of the tub.
- Step 10:** Remove the pressure switch hose from the bottom of the switch.
- Step 11:** It should now be possible for two people to lift the cabinet up and off of the front of the machine and set it aside.

Tub Back, Bearing and Cylinder Assembly

Basket assembly - Small Chassis

Removal

- Step 1:** Remove the top and back panel as described.
- Step 2:** Move the rear channel, that the water valves mount to, forward by removing the five mounting screws.
- Step 3:** Remove the drive belt.
- Step 4:** Remove the overflow hose, tub fill hose and pressure switch hose from the back of the tub.
- Step 5:** Mark the tub back and bearing assembly for ease in assembly later. (see picture)
- Step 6:** Remove the 12 bolts and nuts from the perimeter of the tub back clamp ring. (Two of the twelve bolts are longer and go through the thicker part of the brace where it connects to the frame.)
- Step 7:** Remove the 2 bolts that fasten the clamp ring to the frame.
- Step 8:** The entire tub back and cylinder assembly may be lifted out of the tub (it may be necessary to break the adhesion of the silicone that seals the tub back to the tub). Blocks should be placed under the edges of the cylinder before setting it down to prevent damage to the cylinder flange.

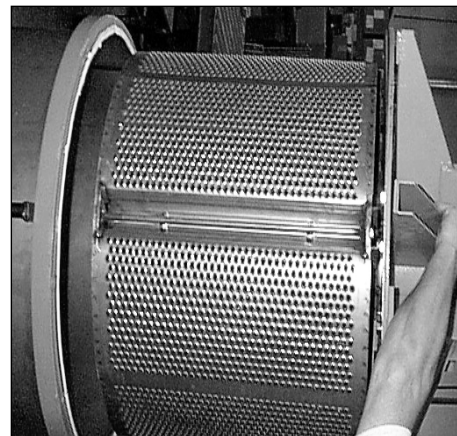

Reassembly

Reverse the procedures to the left paying attention to the following areas

- Step 1:** Lay the washer on its front.
Note: Put a thick pad across the front of the washer, above the door, to protect the handle and coin acceptor.
- Step 2:** Make sure the bearing housing weep holes are located at 12 o'clock and 6 o'clock.
- Step 3:** Clean the silicone rubber from the back of the outer tub and the perimeter of the tub back where the two meet. There is no gasket in this area.
- Step 4:** Apply a new bead of silicone rubber around the back of the outer tub. (see picture)
- Step 5:** Lower the tub back, bearing and cylinder assembly into the washer outer tub.
- Step 6:** Torque all bolts according to the following charts.
- Step 7:** Use a puller to remove the pulley from the shaft.

Basket Pulley, Bearing Housing, Water Seals and Tub Back

The cast iron basket pulley is retained by a bolt, locking washer and a flat washer - Small Chassis



Removal

- Step 1:** Insert a large screw driver or punch through a spoke in the pulley into the bearing housing support. This keeps the pulley from turning.
- Step 2:** Remove the retaining bolt, lockwasher and flat washer and reinstall just the bolt.
- Step 3:** Use a puller to remove the pulley from the shaft. Watch for tolerance ring.

Reassembly

- Step 1:** Make sure that the tolerance ring is in place inside the pulley.
- Step 2:** The shoulder inside the pulley that holds the tolerance ring should face the back of the washer when installed correctly.
- Step 3:** Use a stack of flat washers and a longer bolt to press the pulley onto the basket shaft.
- Step 4:** Reinstall the retaining bolt, lock washer and flat washer. The shaft end bolt with washer should be installed with a torque value listed in charts in this manual.

Removal of Bearing Housing From Basket Shaft, Bearings and Water Seals



- Step 1:** To remove the tub back assembly, the 6 bolts attaching it to the bearing housing must be removed.
- Step 2:** Remove water seals from the seal mounting plate on the cylinder shaft. These are removed with your fingers.
- Step 3:** The retaining ring next to the front bearing must also be removed.
- Step 4:** The bearings are pressed into the housing and must be pressed back out.

Reinstallation onto Basket Shaft

- Step 1:** Carefully set the assembly over the shaft engaging the bearings and bearing spacer.
- Step 2:** The tolerance ring that fits inside the pulley should be placed in position (see Basket Pulley Reassembly for correct positioning).
- Step 3:** The pulley should then be started onto the shaft. A stack of flat washers and a longer pulley bolt will be required to pull the basket shaft through the bearings and pulley.
- Step 4:** Install the shaft end bolt with washers and torque to specifications in Bolt Torque Chart.
- Step 5:** See Tub Back, Bearing and Cylinder Assembly for installation of complete assembly back into washer.

Reassembly - Small Chassis

Step 1: When installing new bearings into a bearing housing, first press the front (large) bearing into the housing until it bottoms. With the bearing spacer in place, press the rear bearing in until the spacer is snug between the two bearings. Be sure and reinstall the retaining ring in front of the front bearing (see picture).

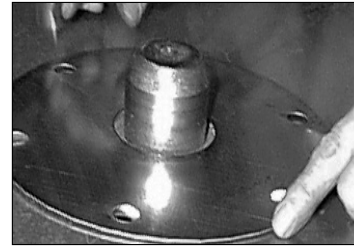

Step 2: The tub back assembly should be reattached to the bearing housing with the 6 mounting bolts and torqued according to the torque chart.
Note: The bead of silicone that seals each bolt to the tub back. This must be cleaned and replaced upon reassembly (see picture).

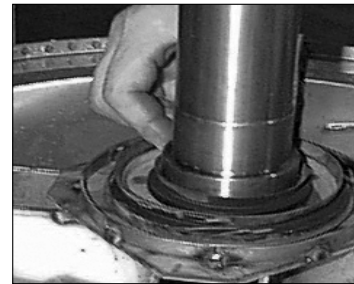

If the 6 support assemblies have been removed from the bearing housing, the 6 rear bearing housing bolts should be torqued according to the chart also.

Step 3: The primary and secondary seals that mount on the sealing ring may be slid over the shaft and seated on the metal sealing ring. In the unlikely event that the metal ring that mounts these sealing rings were to be damaged or moved, a new one would need to be pressed on. The ring must be pushed against the stop on the shaft. Before installing the new sealing ring, a bead of silicone should be put on the basket shaft (see picture). After installing the seals, lubricate the faces of the seals with silicone grease (see picture).

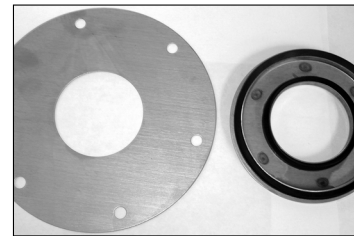

Cylinder Removal - Large Chassis

- Step 1:** Remove the top panel as described previously.
Step 2: Remove lower service panel as described previously.
Step 3: Remove front panel as described previously.
Step 4: Remove masking ring as described previously.
Step 5: Remove door lock assembly. (Leave wires & pull rod in place)
Step 6: Remove clothes door.
Step 7: Remove tub front clamp ring.
Step 8: Remove tub front. Use a flat screw driver to pry the tub front loose.
Step 9: Remove the rear access panel.
Step 10: Remove the drive belts.
Step 11: Remove drive pulley. Remove 3 retaining screws. Insert (3) 3/8 16 x 2" screws into the threaded removal holes. Alternately tighten these screws evenly to pull the pulley off.
Step 12: Remove pulley hub. Drive a flat screw driver into the slot in the hub and pull it from the shaft.
Step 13: Install cylinder puller. (Snap On part #CJ-84-C) Be sure to thread a 5/8-11 NC bolt into the end of the cylinder shaft to protect the threads. Push the basket out.

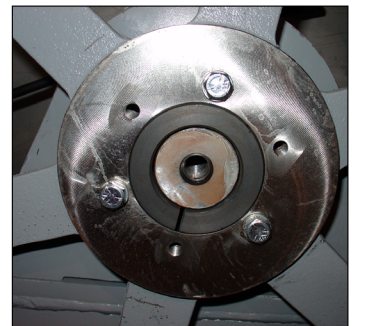
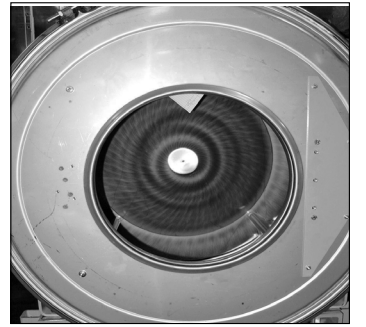

Bearing Housing Assembly - Large Chassis

Removal

- Step 1: Remove cylinder from washer (see Cylinder (basket) removal).
Step 2: Remove 6 7/16" tub back to bearing housing cap screws.
Step 3: Remove 6 3/4" bearing housing to frame bolts.
Step 4: Remove bearing housing from frame.
Step 5: Remove the retaining ring next to the front bearing.
Step 6: The bearings are pressed into the housing and must be pressed back out.

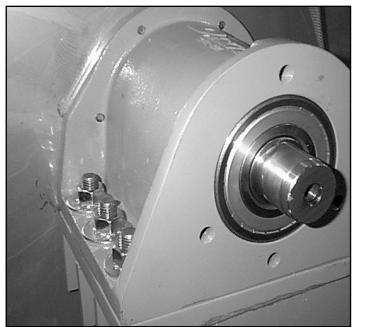

Reassembly

- Step 1: When installing new bearings into a bearing housing, first press the front (large) bearing into the housing until it bottoms and install the snap ring. With the bearing spacer in place, press the rear bearing in until the spacer is snug between the two bearings.

NOTE: If the tub-back water-seal mating ring has been moved it must be cleaned and resealed

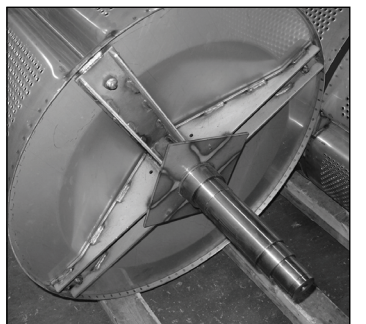

Water Seals - Large Chassis

Replacement

- Step 1:** Remove cylinder from washer (see Cylinder (basket) removal).
- Step 2:** Remove water seals from the seal mounting plate on the cylinder shaft. These are removed with your fingers.
- Step 3:** The primary and secondary seals that mount on the sealing ring may be slid over the shaft and seated on the metal sealing ring with your fingers. In the unlikely event that the metal ring that mounts these sealing rings were to be damaged or moved, a new one would need to be pressed on. The seal mounting ring must be pushed against the stop on the shaft. After installing the seals, lubricate the faces of the seals with silicone grease.
- Step 4:** Install cylinder (see Cylinder (basket) reassembly).

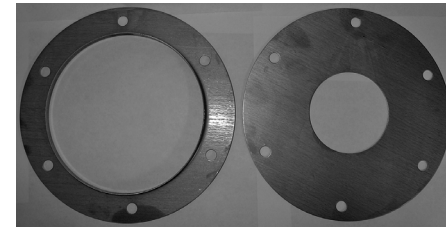

Guard Ring & Mating Ring

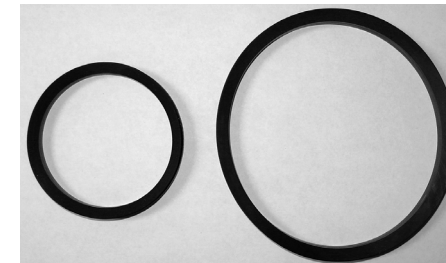

Seals

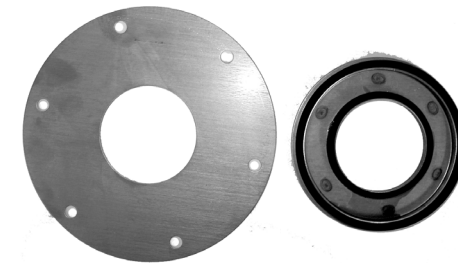

Mating Ring & Mounting Ring

Outer Tub - Large Chassis

Removal

- Step 1:** The outer tub can easily be removed when the tub front, cylinder and bearing housing has been removed as outlined previously.
- Step 2:** At that point the only attachments to the chassis are the two front strap mounting bolts.

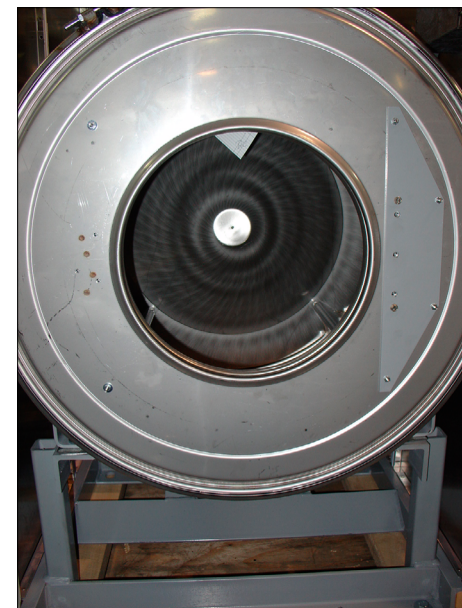

Reassembly of the Cylinder - Large Chassis

- Step 1:** Use the hub of the drive pulley, a stack of 5/8" flat washers and a 3" long 5/8" bolt to pull the cylinder shaft through the bearings. After the 3" bolt a 2" long bolt will be required to finish pulling the cylinder shaft through.
- Step 2:** Remove the 1/2" bolt and nut from the top of the outer tub clamping band.
- Step 3:** Install Dexter Tool part # 8545-056-001 on the back of the outer tub to adjust tub front to cylinder clearance. Thread 5/8" bolt through tool and into cylinder shaft. Push the outer tub forward 1/4" to 1/2" with tool 8545-056-001 by tightening the 5/8" bolt. This will ease the installation of the outer tub front.
- Step 4:** Clean the silicone rubber off the tub front and the outer tub.
- Step 5:** Install new bead of silicone rubber on tub front.
- Step 6:** Install tub front.
- Step 6A:** Align hole in top of tub front with notch in top of outer tub.
- Step 6B:** Use 4-6 #11R vise grip clamps to hold tub front to outer tub. A rubber mallet may be needed to properly seat the tub front into the outer tub.
- Step 6C:** Install tub front gasket around outer edge of tub front and outer tub flange. The opening should be centered at the top.
- Step 6D:** Remove vise grips. The tub front gasket will hold the tub front in place.
- Step 7:** Install tub front clamp ring and tighten. Tap around the clamp ring with a rubber mallet to seat the ring and gasket while tightening the clamp ring bolt.
- Step 8:** Adjust clearance between the outer tub front and the front lip of the cylinder to 5/16".
- Step 9:** Tighten the outer tub clamping band.
- Step 10:** If necessary, the outer tub may be adjusted up or down and side to side with the 2 bolts that fasten the bottom of the outer tub clamping band to the frame.
- Step 11:** Remove Dexter Tool part 8545-056-001 from the back of the outer tub.
- Step 12:** Install drive pulley.
- Step 12A:** Install hub on cylinder shaft.
- Step 12B:** Hold hub against rear bearing with 5/8" bolt and flat washer in end of cylinder shaft.
- Step 12C:** Line up 3 unthreaded holes in pulley with the 3 threaded holes in hub.
- Step 12D:** Insert 3 pulley bolts and tighten evenly alternating bolts to 30ft/lbs.
- NOTE:** Overtightening or uneven tightening can break drive pulley.
- Step 13:** Install drive belts & back panel.
- Step 14:** Install door lock. All mounting holes should be sealed with silicone rubber.
- Step 15:** Install door, masking ring, front panel, lower service panel and top.

T-350 Bolt Torque Chart				
Bolt Size	Bolt Part Number	Qty.	Where Used	Torque
1/2-13 x 3"	9545-017-012	1	Belly Band Ends at Top	20-30 ft-lb
1/2-13 x 1 1/4"	9545-017-009	4	Front/Rear Rings mounting to Base Legs	70-110 ft-lb
3/8-16 x 1 1/2"	9545-029-003	12	Tub Back Outer Bolts	45-80 ft-lb
1/2-13 x 1 1/4"	9545-017-009	6	Bearing Housing to Tub Back	70-110 ft-lb
3/8-16 x 1 1/2"	9545-029-003	6	Bearing Housing to Wedge - Pulley End	45-80 ft-lb
1/2-13 x 1 1/4"	9545-017-009	1	End of Shaft	45-80 ft-lb
5/16-18 x 7/8"	9545-028-015	2	Motor Pulley Set Screws (Loctite)	190-200 in-lb

T-450 Bolt Torque Chart				
Bolt Size	Bolt Part Number	Qty.	Where Used	Torque
1/2-13 x 2 1/2"	9545-017-016	1	Belly Band Ends at Top	30-40 ft-lb
5/8-11 x 1 1/2"	9545-060-001	4	Front/Rear Rings mounting to Base Legs	120-150 ft-lb
7/16-14 x 2"	9545-059-002	12	Tub Back Outer Bolts	100-125 ft-lb
5/8-11 x 1 1/2"	9545-060-001	6	Bearing Housing to Tub Back	120-150 ft-lb
7/16-14 x 1 1/2"	9545-059-003	6	Bearing Housing to Wedge - Pulley End	100-125 ft-lb
5/8-11 x 1 1/2"	9545-060-001	1	End of Shaft	100-125 ft-lb
5/16-18 x 7/8"	9545-028-015	2	Motor Pulley Set Screws (Loctite)	190-200 in-lb

T-650 Bolt Torque Chart				
Bolt Size	Bolt Part Number	Qty.	Where Used	Torque
1/2-13 x 2"	9545-017-013	2	Tub Feet to Base	70-110 ft-lb
3/8-16 x 3"	9545-029-009	1	Front Clamp Ring Ends	100-120 in-lb
7/16-14 x 1"	9545-059-004	6	Bearing Housing to Tub Back (Loctite)	60-80 ft-lb
3/4-10 x 3"	9545-057-002	6	Bearing Housing to Base	200-300 ft-lb
5/8-11 x 2"	9545-060-004	1	End of Shaft	100-125 ft-lb
5/16-18 x 7/8"	9545-028-015	2	Motor Pulley Set Screws (Loctite)	190-200 in-lb
#10-32	8640-413-006	6	Soap Box Nuts	10-20 in-lb

T-950 Bolt Torque Chart				
Bolt Size	Bolt Part Number	Qty.	Where Used	Torque
1/2-13 x 2"	9545-017-013	2	Tub Feet to Base	70-110 ft-lb
3/8-16 x 3"	9545-029-009	1	Front Clamp Ring Ends	100-120 in-lb
7/16-14 x 1"	9545-059-004	6	Bearing Housing to Tub Back (Loctite)	60-80 ft-lb
3/4-10 x 3"	9545-057-002	6	Bearing Housing to Base	200-300 ft-lb
5/8-11 x 1 1/2"	9545-060-001	1	End of Shaft / Large Washer	100-125 ft-lb
3/8-16 x 2"	9545-029-011	3	Drum Pulley Bushing (Loctite)	23-32 ft-lb
1/4-20 x 1"	9545-018-024	3	Motor Pulley Screws (Loctite)	80-90 in-lb
#10-32	8640-413-006	6	Soap Box Nuts	10-20 in-lb

T-1450 & T-1800 Bolt Torque Chart				
Bolt Size	Bolt Part Number	Qty.	Where Used	Torque
1/2-13 x 2"	9545-017-013	2	Tub Feet to Base	70-110 ft-lb
3/8-16 x 3"	9545-029-009	1	Front Clamp Ring Ends	100-120 in-lb
7/16-14 x 1"	9545-059-004	6	Bearing Housing to Tub Back (Loctite)	60-80 ft-lb
7/8-9 x 3 1/2"	9545-066-001	6	Bearing Housing to Base	600-650 ft-lb
3/4-10 x 1 1/2"	9545-057-004	1	End of Shaft / Large Washer	120-130 ft-lb
3/8-16 x 2"	9545-029-011	3	Drum Pulley Bushing (Loctite)	28-32 ft-lb
1/4-20 x 1"	9545-018-024	3	Motor Pulley Screws (Loctite)	80-90 in-lb
#10-32	8640-413-006	4	Soap Box Nuts	10-20 in-lb

Section 6:

Service Electrical Components

Control Mounting Trough

Remove top panel to access control trough. (see Removing Top Panel) It sets on the right side of the machine and holds the control PCB's, transformers, and pressure switch.

Main Data Communication Cable

Goes between front PCB board and Variable Frequency Drive unit mounted center rear of machine. It has telephone type connectors at each end and is inserted at Controller PCB and the Variable Frequency Drive.

Fuses

The fuses mount inside the control trough. It carries all of the controls in the machine but does not include the motor. To replace a fuse, remove fuse and replace.

Controls Transformer

This transformer is mounted at the back of the control trough and steps a range of 208 to 240 volts down to 120 volts for the controls. There are two terminals on the controls transformer for incoming power. One terminal tap is marked for 208 volts use this tap for measured voltage of 200 volts - 215 volts. and the other tap is marked 230 volts for 216 volts - 240 volts. Note: All washers have a controls transformer. Always check the incoming voltage and use the appropriate transformer terminal when installing ALL washers.

Touch Screen Display Assembly

The touch screen display assembly mounts to the control panel. Remove the top panel to access the touch screen display assembly.

Main Relay Printed Circuit Board

Please be sure to be grounded to machine before removal of this board. PCB mounting horizontal in control trough towards front of machine. Remove 4 mounting nuts.

Emergency Stop Button Switch Assembly

The stop button is mounted on right side of machine. Remove the top and access the rear of button. Remove the plastic retainer by unthreading CCW. The switch assembly will have to be removed by pressing down on the plastic clip while pulling the switch body away from the stop button.

Power Connection Terminal Block

This terminal block sets at the rear channel. Incoming power to the washer should connect here.

Delta Variable Frequency Drive:

Main power is connected to terminals L1, L2, and L3 on the Delta drive. If the washer is connected to a three phase source, there should be voltage present on all three terminals. If the washer is connected to single phase power, there should be voltage present on terminals. The voltage should measure 208 Volts to 240 Volts A.C. between phases and connected to if connected to three phase). There is a tolerance of + 10% on the mains voltage (187 Volts to 264 Volts).

Delta VFD Motor Leads:

The wires from the motor are connected to terminals T1, T2, and T3. Since this drive uses pulse width modulation, an accurate current or voltage reading is not possible. Although an accurate current reading is not possible, a balanced current reading should be present while the motor is running.

Delta VFD Dynamic Braking Resistors:

Two, 160 Ohm or 200 Ohm braking resistors (Please check your washer model parts requirements and quantities), are connected in parallel and attached to the drive at terminals B1 and B2. These resistors allow voltage, which is generated by the motor when decelerating, to be dissipated. They will become hot while the motor is slowing down, so care should be taken so as not to come in contact with them. This will prevent an electrical shock and/or a physical burn.

Delta VFD Cooling Fan:

There is a cooling fan attached to the bottom of the Delta drive. This fan will operate when the internal temperature of the drive reaches a predetermined level, the same way the radiator fan in a newer car operates. THE FAN CAN OPERATE ANYTIME POWER IS APPLIED TO THE DRIVE! Remove power to the drive if work is required around the fan.

Section 7:

Electrical Wiring Diagrams & Schematics

Electrical Path Circuit Schematics

Start Circuit

Power travels into the machine on L1, L2, and (L3 if 3 phase used). Power from the L1 & L2 supplies power to the 12VDC power supply. This power being sent to the Control PCB. 115VAC, 24VAC, and the VAC Neutral is created by the control transformer. The 115VAC and 24VAC is being sent to the Power Distribution Board. Power from the L1 and L2 also supplies power to the 12VDC power supply. The 12VDC power is sent directly to the Control PCB on the blue wires.

- All 115VAC power is designated in the machine by red wire connections and the 115VAC neutral is designated by white wires with a red stripe. All 115VAC begins at the power distribution board for 115VAC supplied through a control fuse labeled 1.5 AMP FUSE.
- All 24VAC power is designated in the machine by orange wire connections and the 24VAC neutral is designated by white wires with an orange stripe. All 24VAC begins at the power distribution board for 24VAC supplied through a control fuse labeled 2.0 AMP FUSE.
- All 12VDC power is designated in the machine by blue wire connections and the 12VDC ground is designated by white wires with a blue stripe. Closing the door will engage the door hinge closed switch, sending the J11-5, 12VDC to the blue/white wire and over to the S1 door latched switch. Turning the door handle to the vertical latched position closes the primary door latched switch, returning the 12VDC voltage to the main control PCB on the blue/orange wire at the J11-2 connection. This proves the door is closed and latched and ready for safe operation.

A 12VDC signal to J11-2 of the Control PCB and 120vac at the J4-14 of the relay PCB makes 120vac available to the K10 door lock relay. A continuous 5VDC signal is sent out on the J11-6 brown wire and returned on the brown/white wire to the J11-3 connector of the control PCB. This is passed through the (normally closed) emergency stop button switch.

The Washer is ready for operation.

The cycle is selected by touch selecting the water temperature and cycle options. Start is now selected on the screen. The control signals the relay board to close relay K10 sending 120VAC to the door lock on the red/brown wire. The door lock motor engages and pulls up on the door locking rod which locks the door and closes the S3 and S4 door locking switches. This sends the 12VDC signal back to the control at J11-1 on the blue/grey wire. This 12VDC also pulls in the K4 relay which sends 24VAC to the normally closed K2 relay that powers the Locking Thermoactuator to expand and block the locking mechanism. At the same time the K5 relay is engaged sending an enable signal to the variable frequency drive. 120VAC will go to the door lock assembly from the P11 connector of the relay PCB on the red/brown wire. The door lock motor engages and pulls up on the door locking rod, locking the door and closing the S2 and S3 door locking switches. The Locking Thermoactuator receives 24VAC on the orange/green wire and will expand to block the locking mechanism.

NOTE: If the door locked signal is not received after one second from selecting Start on the screen, no motion occurs and the error message "DOOR SHUT, NOT LOCKED" will appear on the display. The washer will not restart until the power is removed and re-applied.

The door lock gear motor will test the door locking circuit 10 seconds before the end of the first stage after at least 4 minutes and no spin. The control will release the 120VAC to the red/brown wire which will cause the Gear Motor to release which tests the Locking Thermoactuator safety circuit. This release will last for 10 seconds. As long as the Thermoactuator has properly extended to block the door locking mechanism, the machine will continue as normal.

Agitation Circuit

When the 12VDC signal closes the K5 in the Control PCB it closes the loop in the yellow wire from the VFD terminal MI6 back to the DCM on the white/yellow through the stop button. This enables the Drive to operate and allow motion. If the K5 is not closed or the Aux Stop Button is engaged there will be no motion. The K4 closes supplying 120VAC on the red/white to energize the Drain Valve. This supplies power to close the valve. The main control PCB sends data commands to the VFD through the data cable connected at P-2. These commands control all wash cylinder movement. The type of agitation can be programmed in the control settings.

Warm Fill Circuit

During the machine fill, a 12VDC signal is sent on the blue wire from the J12-4 connection of the main control PCB to the water pressure sensor analog contact. This 12VDC returns on the white wire.

The washer fills the tub through the back of the machine with either one or both the C1/C3 cold and H1/H3 hot water fill valves. From the P4 connection of main relay PCB, 120VAC is sent out of the K4 relay on the red/pink wire to the C1/C3 cold water fill valve. 120VAC is sent out of the K2 relay on the red/grey wire to the H1/H3 hot water fill valve depending on the programmed bath temperature. If the washer does not initially reach low water level within 7 minutes the cycle will continue and "SLOW FILL ERROR" will be displayed alternately with the Cycle Progress screen.

The alternating "SLOW FILL ERROR" will be displayed the rest of the cycle even when the "CYCLE DONE" screen is displayed. It will reset when the user opens the door.

If the "SLOW FILL ERROR" occurs after 7 minutes and the water level is still not met at 15 minutes, the washer will come to a controlled stop. The current stage will end, and the cycle will not continue. The "SLOW FILL ERROR" will be displayed on the screen until reset. Even on high fill, as long as the low water level is met one time during a stage, the "SLOW FILL ERROR" will not be displayed during the remainder of the stage. This includes if the low water level is met before 7 minutes, then drops again and requires additional filling.

Wash Circuit

Once the machine has achieved its water level, the wash basket will continue to tumble one direction for 12 seconds, pause, and then reverse direction for 12 seconds. The time on the front display will count down as the bath progresses. The time of the bath is programmable up to 15 minutes per bath. Note: When programming cycles, the wash bath must be programmed for 3 minutes or more.

When the bath ends the control PCB signals the relay PCB to remove 120 VAC power from red/white wire at J4-3 going to the drain valve. With voltage removed, the normally-open, spring-loaded drain valve will open allowing water to exit the machine until the tub is empty. This resets the pressure switch back to an empty level. The same options can be set for each stage through. It is possible to hold the drain valve and keep the bath water in the tub to start the next stage or extend the stage time.

NOTE: The control can be programmed to hold the drain and extend advance into the next stage. This allows for roll over stage possibilities.

Final Rinse Circuit

The display will read Final Rinse and the drain valve will receive 120VAC and close. The basket will fill and tumble the same as the previous baths for the programmed time. The final rinse water temperatures are programmable. Note: When programming cycles, the final rinse bath must be programmed and cannot be set for less than 3 minutes. Also at the beginning of the final rinse bath, the main control PCB will signal the relay PCB to send 120V to the J4-2 connector on the red/violet wire to the C2 cold water valve for 20 seconds to flush the fabric softener dispenser.

Spin and Extract Circuit

Once the water pressure sensor achieves empty level, the washer is capable of a programmed spin speed, from 60 to 200 G-Force at the end of each stage. The control PCB sends a signal to the variable frequency drive via the data cable from P2 to the VFD RJ-11. The rotation as viewed from front during spin will be counter-clockwise. At the end of the spin, the basket will come to a stop with the assistance of the dynamic braking resistors wired in parallel to the variable frequency drive. The washer will then tumble for 45 seconds to let the clothes shake loose from the basket and then stop.

Thermoactuator and Shake Out Circuit

The Lock Thermoactuator is turned off after deceleration from the final spin is complete and just before the additional 3 agitation motions ("shakeout" portion) are beginning. Deceleration from final spin is considered to be complete when the VFD is registering 0 Hz for actual frequency. This condition must be satisfied for the Unlock Thermoactuator to turn on. Once powered this will push the safety block mechanism out of the way of the door lock gear motor lever.

End of Cycle Circuit

Once the machine stopped, 3 things occur:

1. The beeper will signal for 5 seconds letting the user know that it is the end of the cycle. The Display of the Washer will also show, "CYCLE DONE THANK YOU".
2. The control PCB signals the relay PCB to remove power from the red/brown wire at J4-11 which allows the door lock gear motor to unlock.
3. The main control PCB resets when the S1, S2, S3, and S5 opens and door is opened, allowing the display to reset when door is opened.

Vended Drive Motor Inverter Type Motor-Winding Resistance Chart

T-350 X-Series Express Washer

Motor	Winding	Wire #	Resistance	
			Minimum	Maximum
T-350 1ph or 3ph 60hz Main (wash & spin)		T1 & T2	3.71	4.09
Dexter #9376-307-001		T2 & T3	3.71	4.09
Marathon		T1 & T3	3.71	4.09

T-450 X-Series Express Washer

Motor	Winding	Wire #	Resistance	
			Minimum	Maximum
T-450 1ph or 3ph 60hz Main (wash & spin)		T1 & T2	2.25	2.61
Dexter #9376-319-001		T2 & T3	2.25	2.61
Marathon #		T1 & T3	2.25	2.61

T-650 X-Series Express Washer

Motor	Winding	Wire #	Resistance	
			Minimum	Maximum
T-650 1ph or 3ph 60hz Main (wash & spin)		T1 & T2	2.25	2.61
Dexter #9376-319-001		T2 & T3	2.25	2.61
Marathon #		T1 & T3	2.25	2.61

T-950 X-Series Express Washer

Motor	Winding	Wire #	Resistance	
			Minimum	Maximum
T-950 1ph or 3ph 60hz Main (wash & spin)		T1 & T2	.944	1.097
Dexter #9376-329-001		T2 & T3	.944	1.097
Marathon #		T1 & T3	.944	1.097

T-1450 X-Series Express Washer

Motor	Winding	Wire #	Resistance	
			Minimum	Maximum
T-1450 1ph or 3ph 60hz Main (wash & spin)		T1 & T2	.435	.505
Dexter #9376-326-001		T2 & T3	.435	.505
Marathon #		T1 & T3	.435	.505

T-1800 X-Series Express Washer

Motor	Winding	Wire #	Resistance	
			Minimum	Maximum
T-950 1ph or 3ph 60hz Main (wash & spin)		T1 & T2	.944	1.097
Dexter #9376-328-002		T2 & T3	.944	1.097
Marathon #		T1 & T3	.944	1.097

NOTE: Resistance values are measured at the stator. Values at the end of the motor wiring harness may be slightly higher.