



***DEXTER***<sup>®</sup>  
*LAUNDRY*

**PLEASE USE THE TABS LOCATED ON THE  
RIGHT AND LEFT SIDES OF THE DOCUMENT  
TO ADVANCE TO EACH SECTION.**



**DEXTER**  
LAUNDRY



WCAD-Series Vended Washers  
T900,T1200 (100G)  
& T750, T950,T1450(Express Washers 200G)

Parts & Service Manual

**Equipment Safety Warnings**  
**Symbols and Terminology Used in this Equipment**

	Indicates an imminently hazardous situation, which if not avoided, will result in death or serious injury.
	Indicates a potentially hazardous situation, which if not avoided could result in death or serious injury.
	Indicates a potentially hazardous situation which, if not avoided, may result in minor or moderate injury. It may also be used to alert against unsafe practices. Minor burns, pinch points that result in bruises and minor chemical irritation.
	Indicates information or a company policy that relates directly or indirectly to the safety of personnel or protection of property.
	This is the user caution symbol. It indicates a condition where damage to the equipment resulting in injury to the operator could occur if operational procedures are not followed. <b>TO REDUCE THE RISK OF DAMAGE OR INJURY, refer to accompanying documents; follow all steps or procedures as instructed.</b>
	This is the electrical hazard symbol. It indicates that there are <b>DANGEROUS HIGH VOLTAGES PRESENT</b> inside the enclosure of this product. <b>TO REDUCE THE RISK OF FIRE OR ELECTRIC SHOCK, do not attempt to open the enclosure or gain access to areas where you are not instructed to do so. REFER SERVICING TO QUALIFIED SERVICE PERSONEL ONLY</b>
	Caution! There are sharp edges on various sheet metal parts internal to the enclosure. Use safety consciousness when placing or moving your hands while working in the interior of this equipment.
	Caution! To reduce the risk of damage to the Water Inlet Valve, do not supply inlet water with a temperature that exceeds 70° C.  Caution! To reduce the risk of fire or explosion, do not operate this equipment in any hazardous classified (ATEX) environment.

## Equipment Safety Warnings Symbols and Terminology Used in this Equipment



Warning! Do not operate equipment if door glass is damaged in any way.



Warning! Keep clear of rotating parts.



Prohibited! Do not enter this equipment or space.



Prohibited! Do not step or stand on this equipment.



Prohibited! Do not operate without all guards and covers in place.



Prohibited! Do not operate without all guards and covers in place.



Prohibited! Do not wash clothing impregnated with flammable liquids (petrochemical).



Prohibited! Do not allow children to play in or around equipment.

<b>DANGER</b>	Indicates an imminently hazardous situation, which if not avoided, <b>will result</b> in death or serious injury.
<b>WARNING</b>	Indicates a potentially hazardous situation, which if not avoided <b>could result</b> in death or serious injury.
<b>CAUTION</b>	Indicates a potentially hazardous situation which, if not avoided, <b>may result</b> in minor or moderate injury. It may also be used to alert against unsafe practices. Minor burns, pinch points that result in bruises and minor chemical irritation.
<b>NOTICE</b>	Indicates information or a company policy that relates directly or indirectly to the safety of personnel or protection of property.
	This is the user caution symbol. It indicates a condition where damage to the equipment resulting in injury to the operator could occur if operational procedures are not followed. <b>TO REDUCE THE RISK OF DAMAGE OR INJURY, refer to accompanying documents; follow all steps or procedures as instructed.</b>
	This is the electrical hazard symbol. It indicates that there are <b>DANGEROUS HIGH VOLTAGES PRESENT</b> inside the enclosure of this product. <b>TO REDUCE THE RISK OF FIRE OR ELECTRIC SHOCK, do not attempt to open the enclosure or gain access to areas where you are not instructed to do so. REFER SERVICING TO QUALIFIED SERVICE PERSONEL ONLY</b>
	Caution! To reduce the risk of fire or explosion, do not operate this equipment in any hazardous classified (ATEX) environment.



## WARNING



- All washers must be installed in accordance to all applicable electrical, plumbing and all other local codes.
- These installation and operation instructions are for use by qualified personnel only. To avoid injury and electrical shock, do not perform any servicing other than that contained in the installation and operation instructions, unless qualified.



Do not install washers in an explosive atmosphere.



- Care must be stressed with all foundation work to ensure a stable unit installation, eliminating possibilities of excessive vibration.
- Foundation must be level within 13 mm to ensure proper washer operation.



Do not operate washer if door glass is damaged in any way.



Do not wash clothing impregnated with flammable liquids (petrochemical).



## WARNING



Children should be supervised to ensure they do not operate or play in or around equipment.









Keep all panels in place to protect against electrical shock and injury and add rigidity to washer.

This appliance is not intended for use by persons (including children) with reduced physical, sensory or mental capabilities, or lack of experience and knowledge, unless they have been given supervision or instruction concerning use of the appliance by a person responsible for their safety.

A washer should not be allowed to operate if any of the following occur:

- Excessive high water level.
- Machine is not connected to a properly earthed circuit.
- Door does not remain securely locked during the entire cycle.
- Vibration or shaking from an inadequate mounting or foundation

	<b>Warning! Do not operate equipment if door glass is damaged in any way.</b>
	<b>Warning! Keep clear of rotating parts.</b>
	<b>Prohibited! Do not enter this equipment or space.</b>
	<b>Prohibited! Do not step or stand on this equipment.</b>
	<b>Prohibited! Do not operate without all guards and covers in place.</b>
	<b>Prohibited! Do not operate without all guards and covers in place.</b>
	<b>Prohibited! Do not wash clothing impregnated with flammable liquids (petrochemical).</b>
	<b>Prohibited! Do not allow children to play in or around equipment.</b>

	<b>Prohibited! Do not attempt to open, touch, or proceed before referring to the manual or unless qualified.</b>
	<b>Mandatory! Read all supporting documentation before operating or maintaining equipment.</b>
	<b>Mandatory! Disconnect power before servicing equipment.</b>
	<b>Mandatory! Lock out and tag out before servicing this equipment.</b>
	<b>Mandatory! Disconnect water supply before servicing equipment.</b>
	<b>Mandatory! Children should be supervised to ensure they do not operate equipment.</b>

Lined area for notes.

# Dexter Safety Guidelines



## WARNING

These washers are equipped with devices and features relating to their safe operation. To avoid injury or electrical shock, do not perform and service, unless qualified to do so.

### FOR SAFETY

1. Always shut off power and water supply and also discharge capacitors before servicing.
2. Do not overload the washer.
3. Do not attempt to open door if cylinder is in motion or contains water.
4. Do not mechanically force or override door lock in any way.
5. Do not bypass any safety devices of this washer.
6. Do not use volatile or flammable substances in or near this washer.
7. Keep all panels in place. They protect against shock and injury and add rigidity to the washer.

#### A machine should not be allowed to operated if any of the following occur:

- Excessively high water level.
- Machine is not connected to a properly grounded circuit.
- Loading door does not remain securely locked during the entire cycle.
- Vibration or shaking from an inadequate mounting or foundation.

To activate your warranty, be sure to return your red warranty form to the factory. Please have serial number and model ready when calling for assistance.

# Table of Contents

**Section 1: Machine Mounting & Installation**

T-750.....14

T-900 & T-950.....15

T-1200 & T-1450.....16

T-750 Installation .....17

T-900 Installation.....18

T-950 Installation .....19

T-1200 Installation.....20

T-1450 Installation.....21

**Section 2: Machine Installation & Operating Instructions**

Basic Installation.....24

Electrical Connections & Fusing Requirements .25

Emergency Stop Button .....26

Machine Operating Instructions .....26 & 27

Detergent Measurements by Model.....27

**Section 3: Machine Programming Instructions**

Programming Instructions & Price Programming .....30

Water Temperature Pricing .....30 & 31

Wash Cycle

Programming.....31 & 32

Coin Washer Cycle Parameter Ranges .....33

Coin Washer Default Cycle & Rapid Advance Mode .....34

**Section 4: Trouble Shooting**

Common Troubleshooting Solutions Pages..36-38

Troubleshooting Machine Fault

Errors Pages.....39-43

Motor Resistance Chart.....43

Variable Frequency Drive Control

Digital Readout Faults .....44

**Section 5:  
Machine Service Procedures**

Lower Service Panel Removal .....46  
Top Panel Removal.....46  
Front Panel Removal .....46  
Back Panel Removal.....45  
Drain Valve Access.....46  
Drain Valve Cleaning .....46  
Detergent Dispenser .....46  
Vaccuum Breaker/  
Air Gap.....46  
Water Valves .....46  
Door Lock Assembly Operation .....47  
Adjustment for the Door Lock  
    Assembly .....47 & 48  
Adjusting the Loading Door .....49  
Loading Door Removal .....49  
Loading Door Hinge Removal.....49  
Loading Door Disassembly .....50  
Loading Door Reassembly .....50  
Control Panel Name Plate Decal.....50  
Name Plate Removal .....50  
Re-Installation of Name Plate.....50  
Outer Cabinet Removal .....51  
Door Locking Solenoid .....51  
Thermoactuators .....51  
Lock Thermoactuator .....51  
Unlock Thermoactuator .....51  
Drive Belt Removal.....51  
Tub Back, Bearing and Cylinder Assembly .....52  
Basket Pulley, Bearing Housing,  
    Water Seals & Tub Back .....52 & 55  
T-750 Bolt Torque Chart.....55  
T-9000, T-950, T-1200 & T-1450  
    Bolt Torque Chart .....55

**Section 6:**  
Control Mounting Trough.....58  
Main Data Communication Cable.....58  
Circuit Breaker/Fuse .....58  
Main Control Printed Circuit Board.....58  
PCB Transformer Step Down.....58

Controls Transformer.....58  
Main Relay Printed Circuit Board .....58  
Pressure Switch .....59  
Power Connection Terminal Block .....59  
LED Printed Circuit Board Temperature & Start/  
    Display Push Button .....59  
Emergency Stop Button & Switch Assembly.....59  
Add Bleach LED .....59  
Delta Variable Frequency Drive .....60  
Delta VFD Motor Leads.....60  
Delta VFD Dynamic Braking  
Resistors .....60  
Delta VFD Cooling Fan .....60

**Section 7:**

Machine Electrical & Wiring Schematics  
Start Circuit .....62  
Fill Circuit .....62  
Wash Circuit .....63  
Drain, Rinse 1 & 2 & Final Rinse Circuit .....63  
Extract Circuit.....63  
Thermoactuator and Shake Out Circuit.....64  
End of Cycle Circuit .....65  
Diagrams & Schematics..... 66- 75

**Section 8:  
Parts Data**

A-Series Accessories..... 78  
Wiring Harness Part # by Model..... 79  
Cabinet and Front Panel Group Part #  
    by Model ..... 80 & 83  
Soap Dish.....84 & 85  
Rear View Access Part # by Model.....86& 87  
Cylinder, Seals & Bearings Part #  
    by Model ..... 88 & 89  
Door Lock Part # by Model .....90-93  
Loading Door Part # by Model ..... 94 & 95  
Water Inlet Part # by Model..... 96 & 97  
Water Inlet Valve Breakdown I..... 98 & 99  
Drain Valve Group Part # by Model.....100  
Chassis and Drain Part # by Model .... 102 & 103

Control Panel Part # by Model..... 106 & 107  
Integrated Easy Card Control Panel Part #  
    by Model ..... 118 & 119  
Electrical Components -  
    Top Compartment ..... 120 & 121  
Coin Handling Group Part # by Model . 122 & 123  
Labels and Diagrams All WCAD Models ..... 110

**Section 9:**

**Coin Handling**

Micro Switch Mech.....112-113  
Optical Switch.....114  
Imonex .....115  
Munzpurfer Electronic + Troubleshooting...116-122

**Section 10:**

**EasyCard Interface**

Intergrated EasyCard Control Panel.....152-153  
EasyCard Schematics & Diagrams.....154-161

**Section 11:**

**50 Hz Models**

-59 Parts.....164 & 165  
-21 Parts.....166  
50HZ Diagrams & Schematics.....168-182

**Section 12:**

**Maintenance**

Preventative Maintenance .....184

Specifications for below models  
are outlined in this book:

T-750	WCAD50-KCS-12SZ	208-240 V	60 Hz	Phase 1 & 3
T-750	WCAD50-KCS-12SZ EC	208-240 V	60 Hz	Phase 1 & 3 Easy Card
T-900	WCAD60-KCS-12	208-240 V	60 Hz	Phase 1 & 3
T-900	WCAD60-KCS-12 EC	208-240 V	60 Hz	Phase 1 & 3 Easy Card
T-950	WCAD60-KCS-12SZ	208-240 V	60 Hz	Phase 1 & 3
T-950	WCAD60-KCS-12SZ EC	208-240 V	60 Hz	Phase 1 & 3 Easy Card
T-1200	WCAD80-KCS-12	208-240 V	60 Hz	Phase 1 & 3
T-1200	WCAD80-KCS-12 EC	208-240 V	60 Hz	Phase 1 & 3 Easy Card
T-1450	WCAD80-KCS-12SZ	208-240 V	60 Hz	Phase 1 & 3 Easy Card

T-750 Machine Dimensions

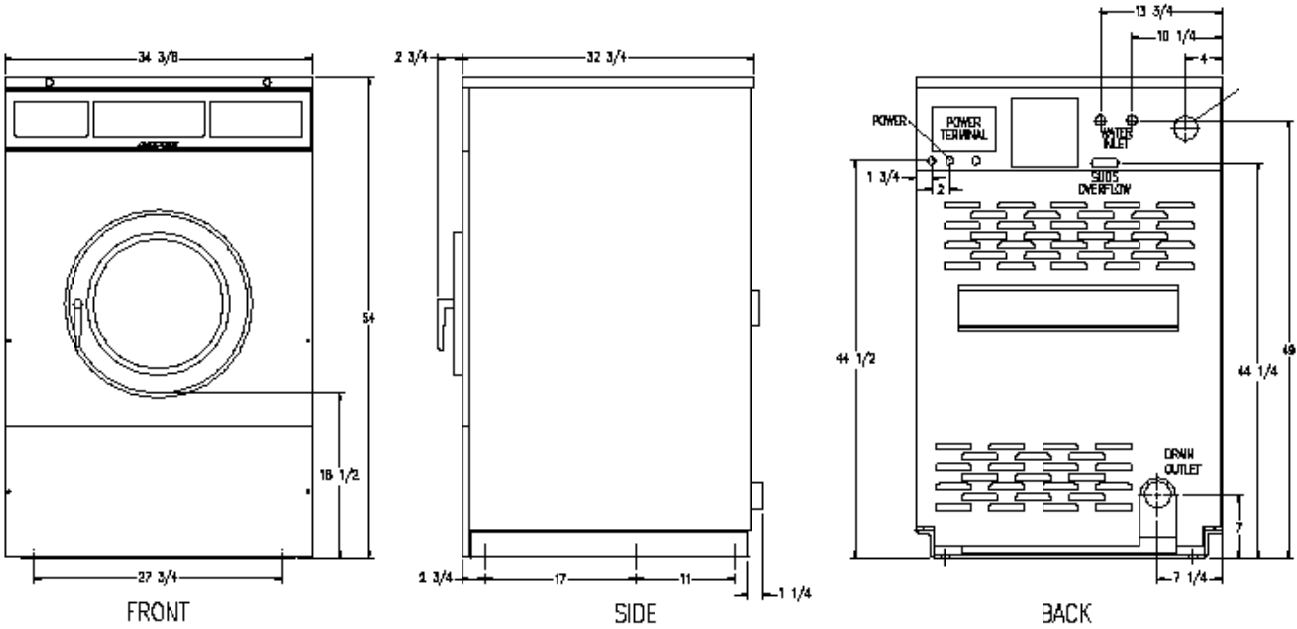

**Section 1:**  
Machine  
Mounting

## T-900 Machine Dimensions

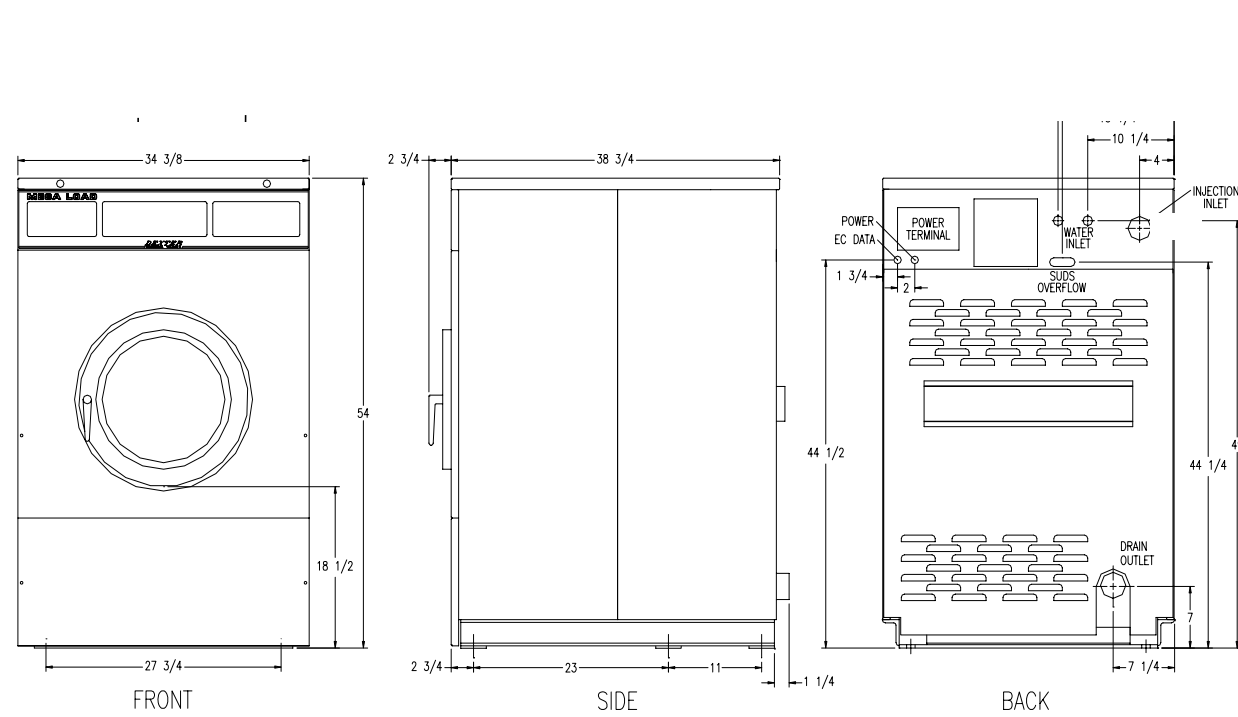

## T-1200 Machine Dimensions

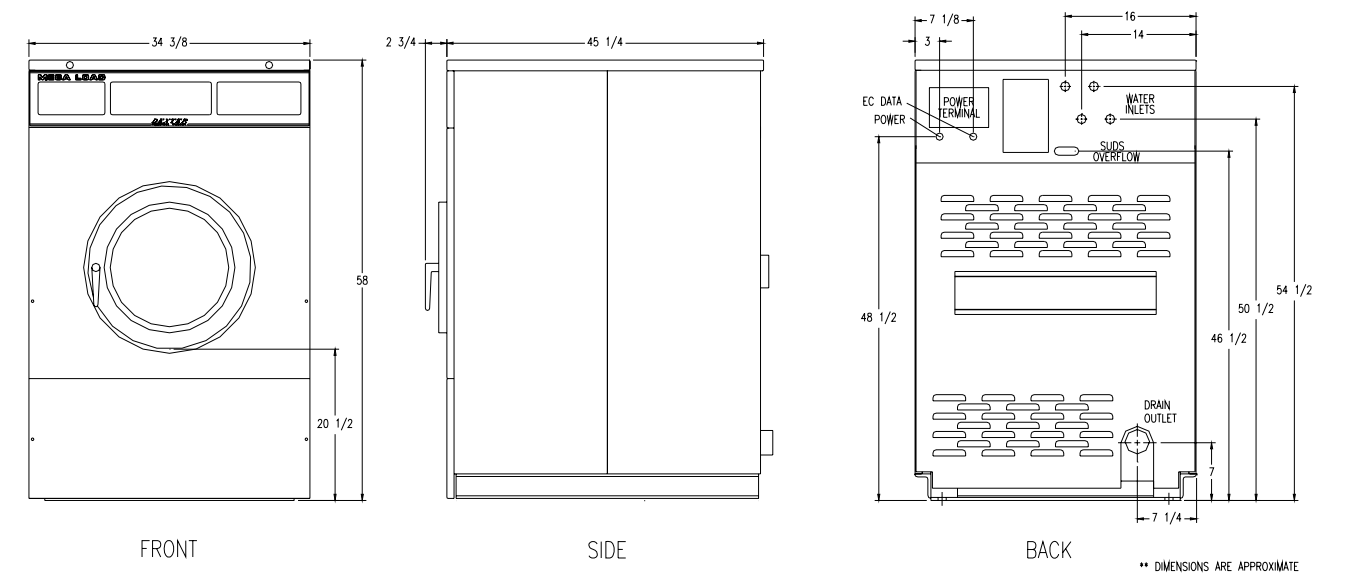

## T-950 Machine Dimensions

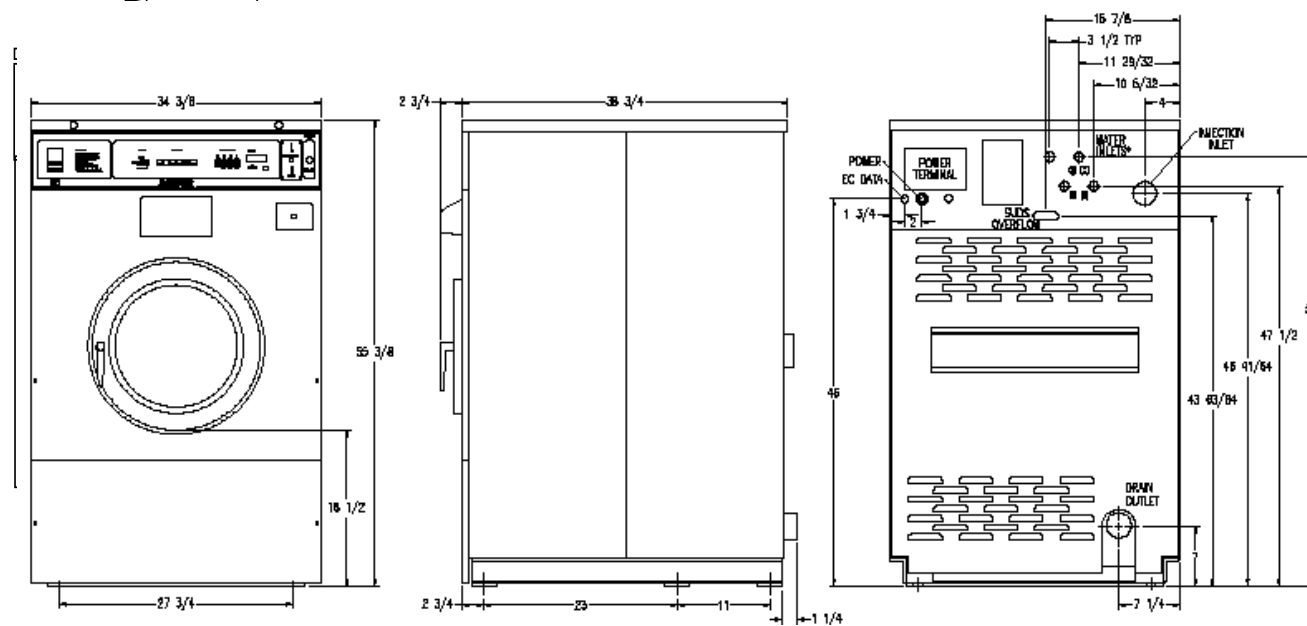

## T-1450 Machine Dimensions

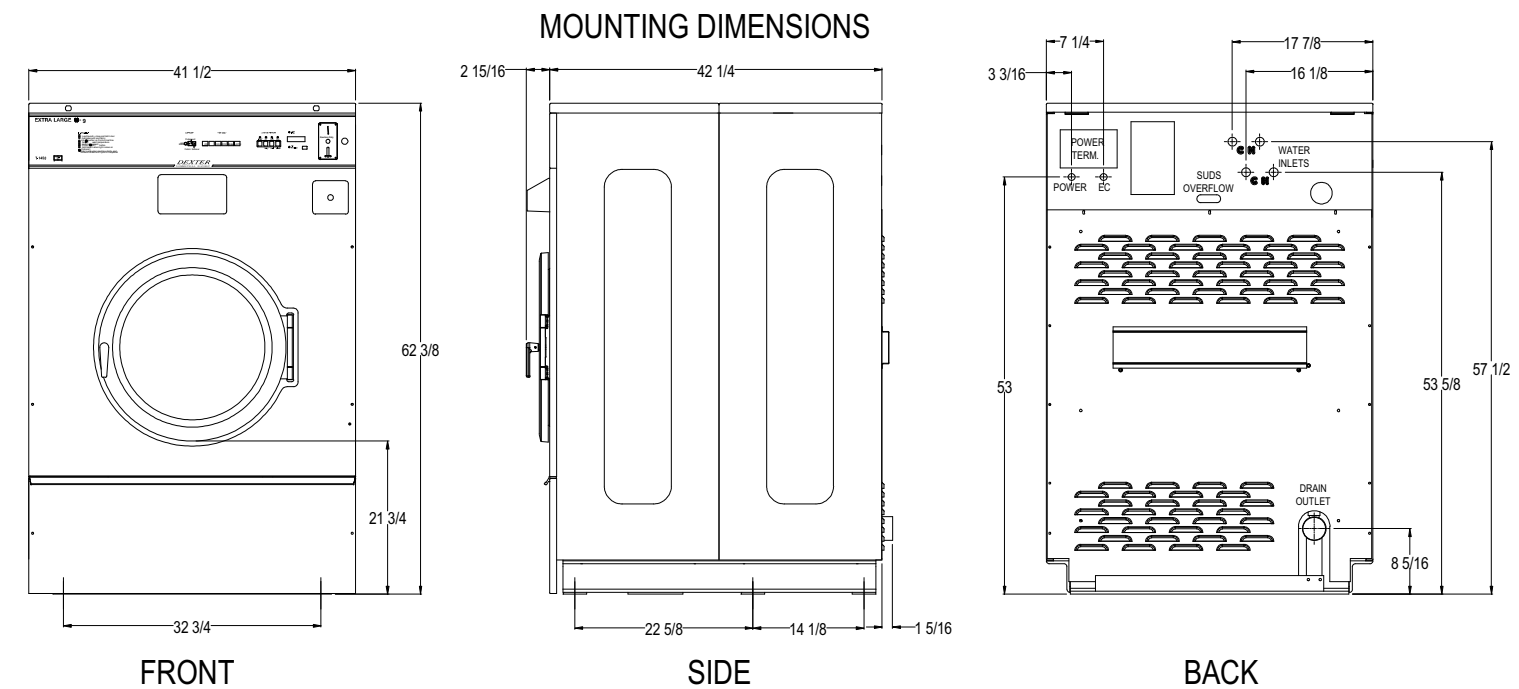

# T-750 Mounting Dimensions

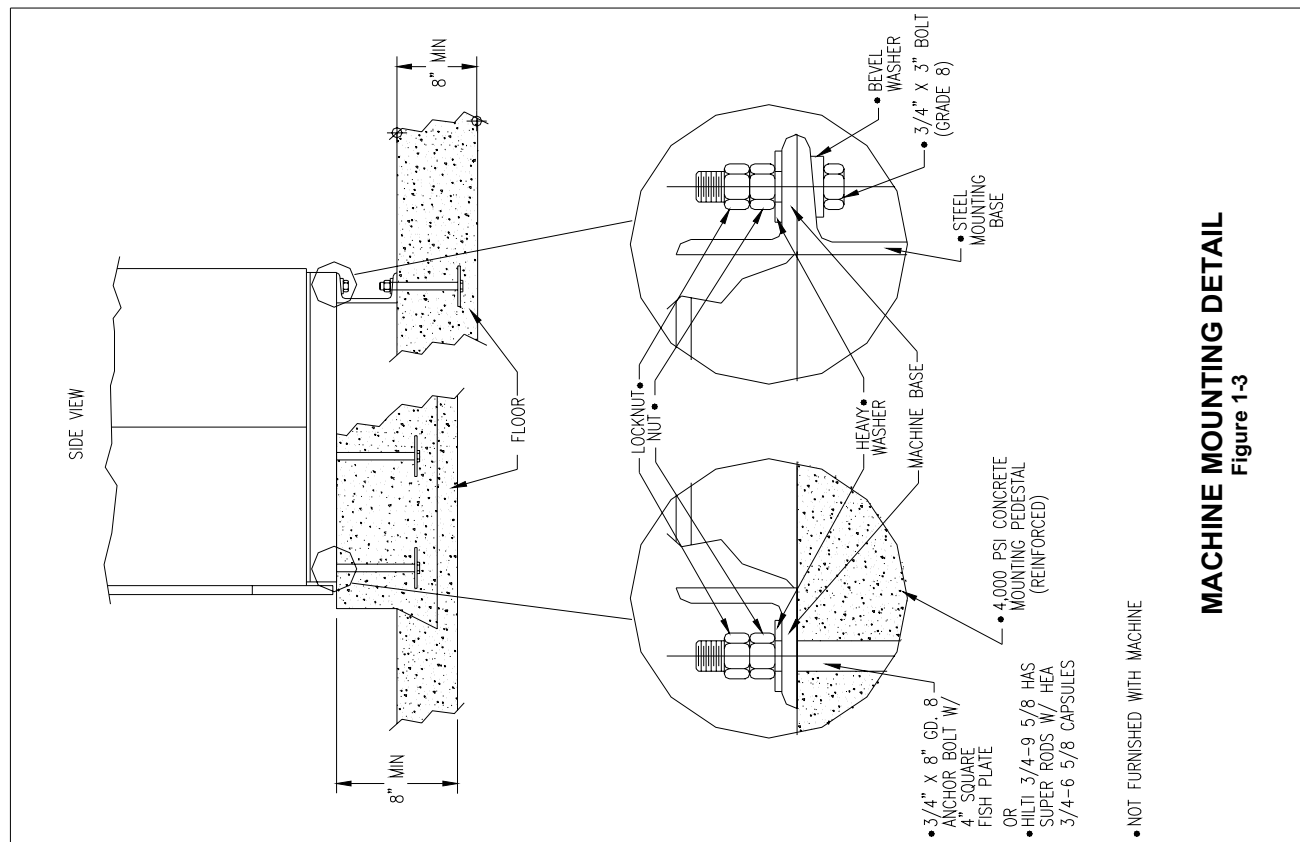

3/4"x 8" GD. 8 BOLTS HEADED BY 4" SQ. FISH PLATE OR EQUIV.  
OR  
'HILTI' ADHESIVE ANCHORING SYSTEM. USE HILTI 'HVU' 3/4-6 5/8 ADHESIVE CAPSULES AND HILTI 'HAS' SUPER RODS 3/4-9 5/8 FOR MORE INFORMATION CALL HILTI CUSTOMER SERVICE 1-800-879-8000

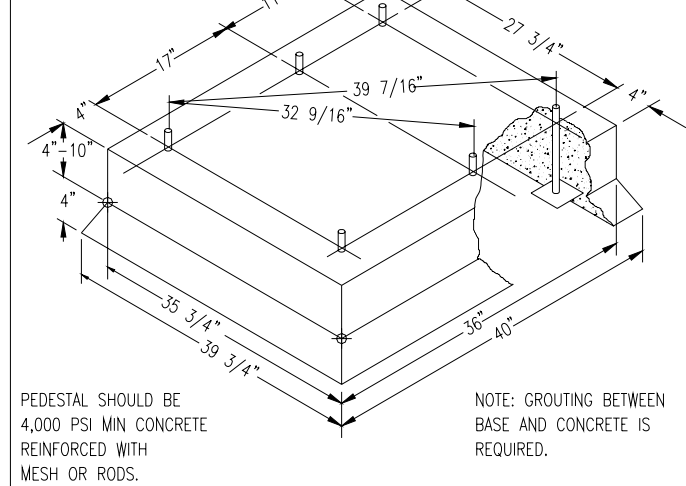

**CONCRETE PEDESTAL MOUNTING**  
Figure 1-1

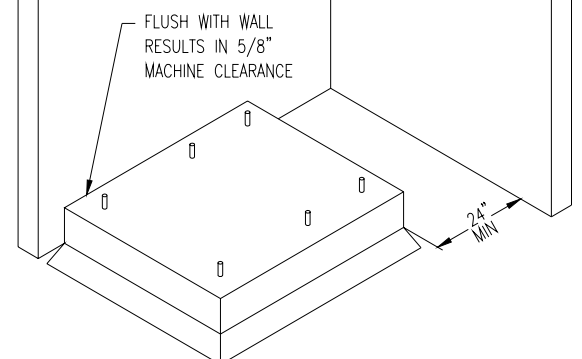

**FLOOR OUTLINE**  
Figure 1-2

# T-900 Mounting Pad Dimensions

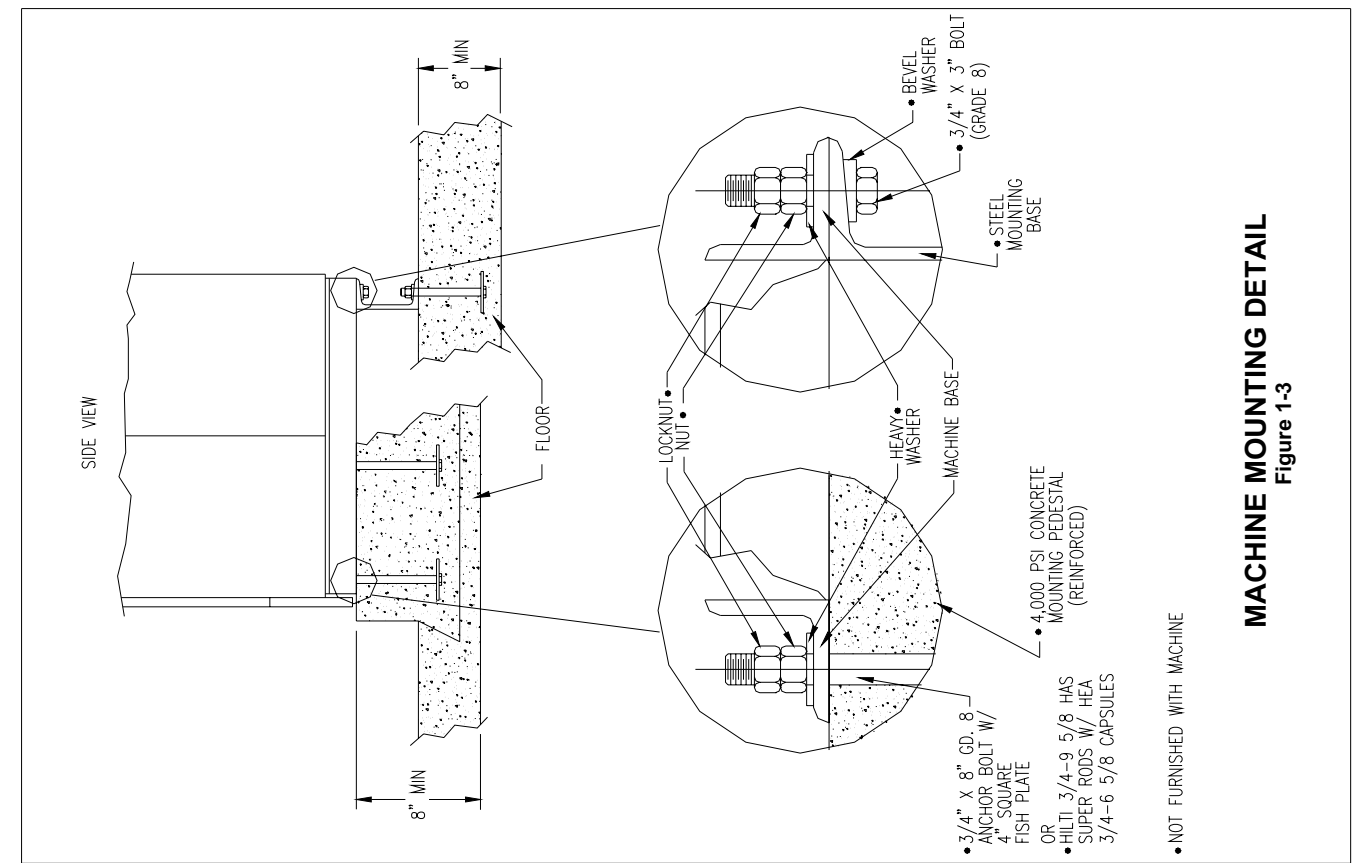

3/4"x 8" GD. 8 BOLTS HEADED BY 4" SQ. FISH PLATE OR EQUIV.  
OR  
'HILTI' ADHESIVE ANCHORING SYSTEM. USE HILTI 'HEA' 3/4-6 5/8 ADHESIVE CAPSULES AND HILTI 'HAS' SUPER RODS 3/4-9 5/8 FOR MORE INFORMATION CALL HILTI CUSTOMER SERVICE 1-800-879-8000

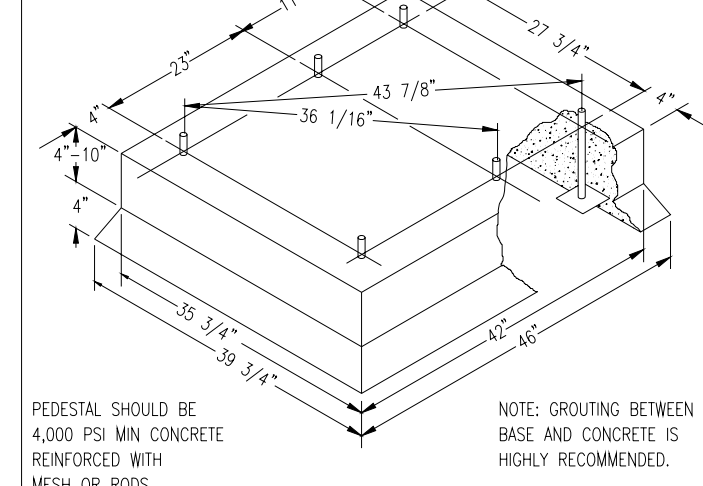

**CONCRETE PEDESTAL MOUNTING**  
Figure 1-1

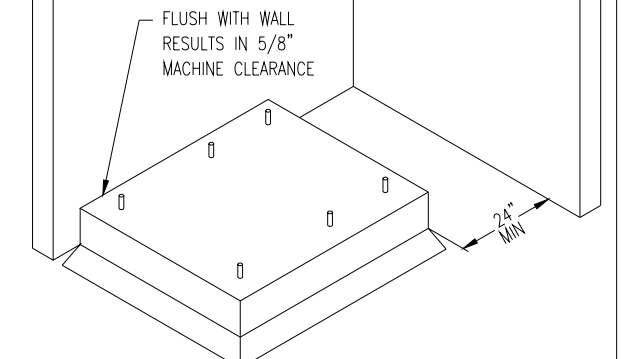

**FLOOR OUTLINE**  
Figure 1-2

# T-950 Mounting Dimensions

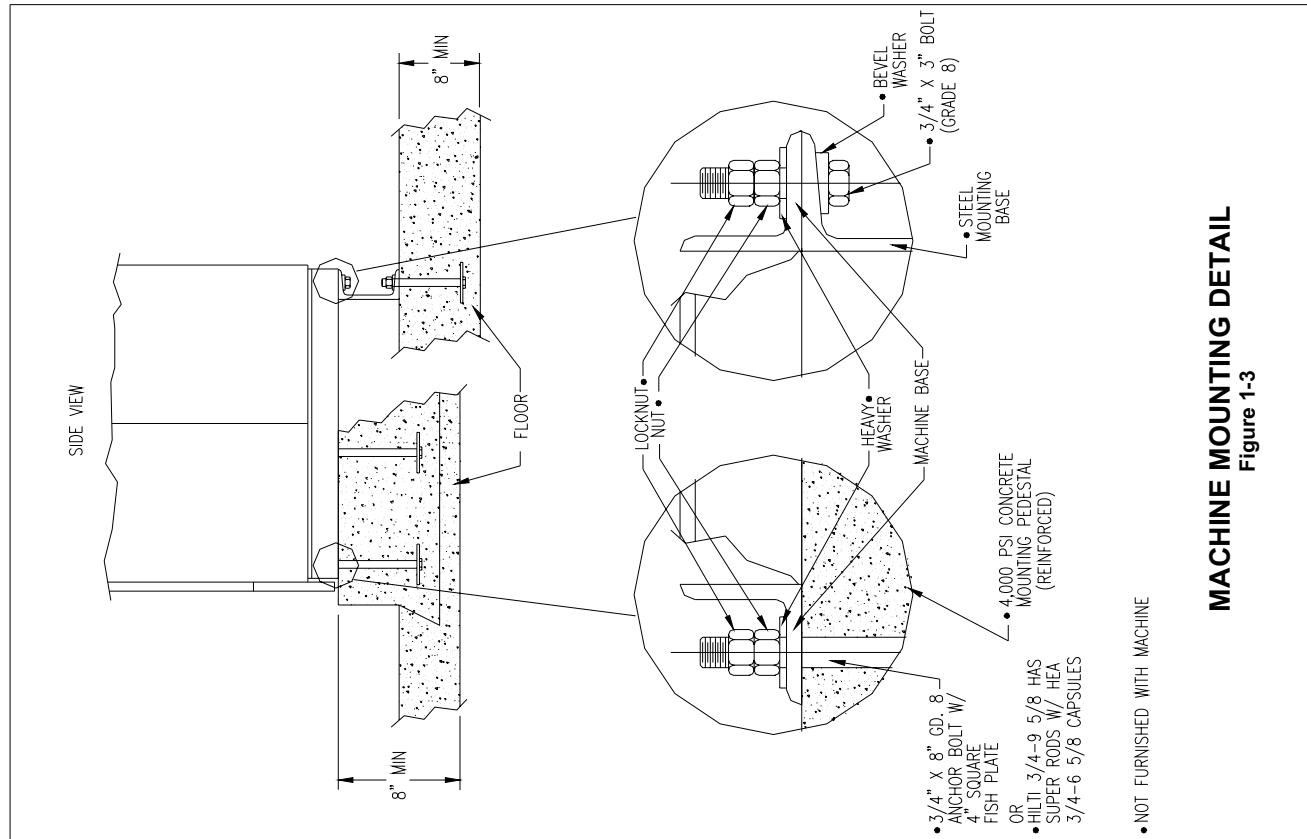

3/4" X 8" GD. 8 BOLTS HEADED BY 4" SQ. FISH PLATE OR EQUIV.  
OR  
'HILTI' ADHESIVE ANCHORING SYSTEM.  
USE HILTI 'HEA' 3/4-6 5/8 ADHESIVE CAPSULES AND HILTI 'HAS' SUPER RODS 3/4-9 5/8  
FOR MORE INFORMATION CALL HILTI CUSTOMER SERVICE 1-800-879-8000

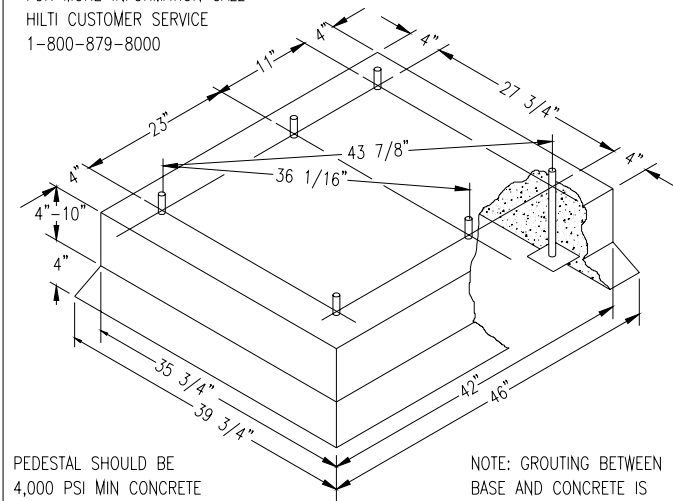

**CONCRETE PEDESTAL MOUNTING**  
Figure 1-1

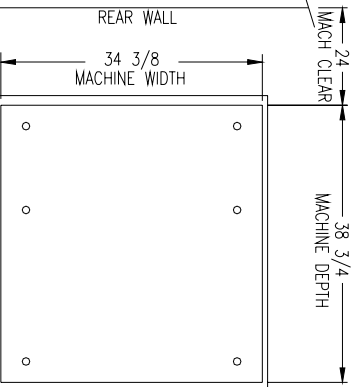
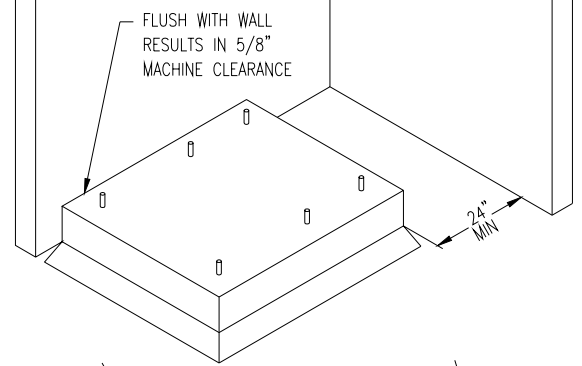

**FLOOR OUTLINE**  
Figure 1-2

# T-1200 Mounting Pad Dimensions

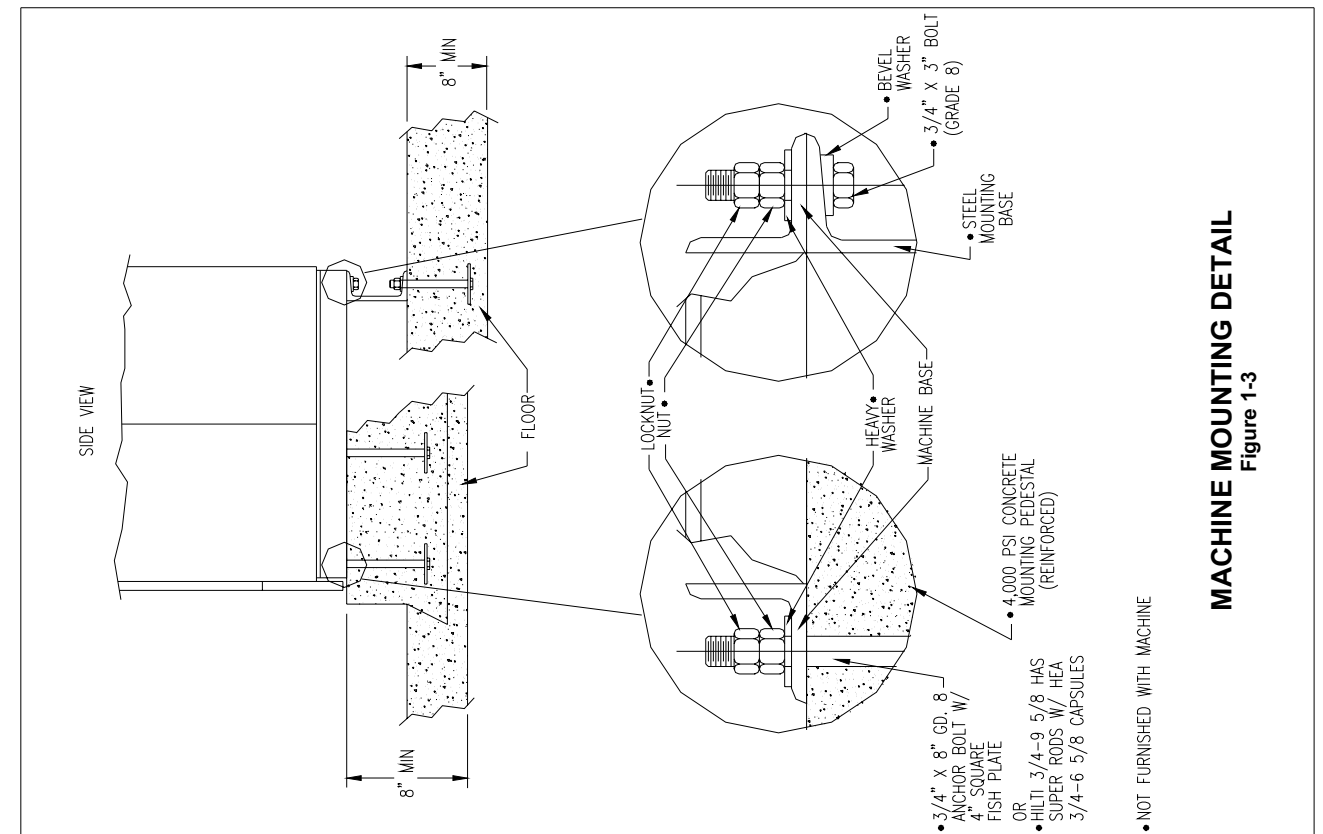

3/4" X 8" GD. 8 BOLTS HEADED BY 4" SQ. FISH PLATE OR EQUIV.  
OR  
'HILTI' ADHESIVE ANCHORING SYSTEM.  
USE HILTI 'HEA' 3/4-6 5/8 ADHESIVE CAPSULES AND HILTI 'HAS' SUPER RODS 3/4-9 5/8  
FOR MORE INFORMATION CALL HILTI CUSTOMER SERVICE 1-800-879-8000

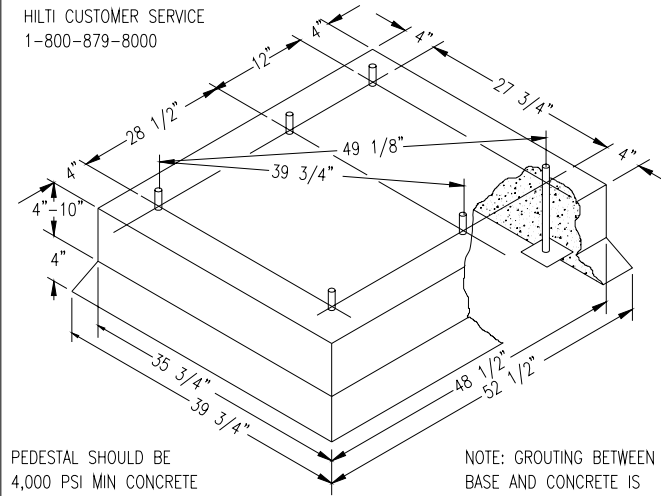

**CONCRETE PEDESTAL MOUNTING**  
Figure 1-1

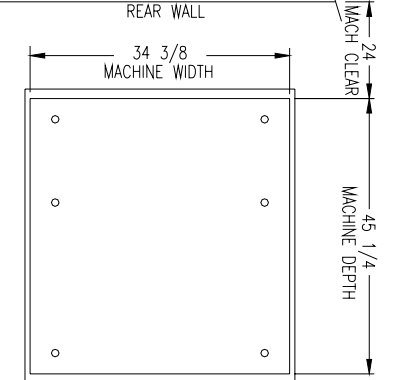
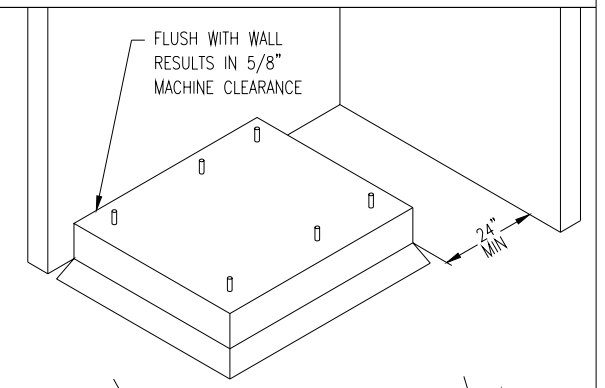

**FLOOR OUTLINE**  
Figure 1-2

# T-1450 Mounting Pad Dimensions

## Notes

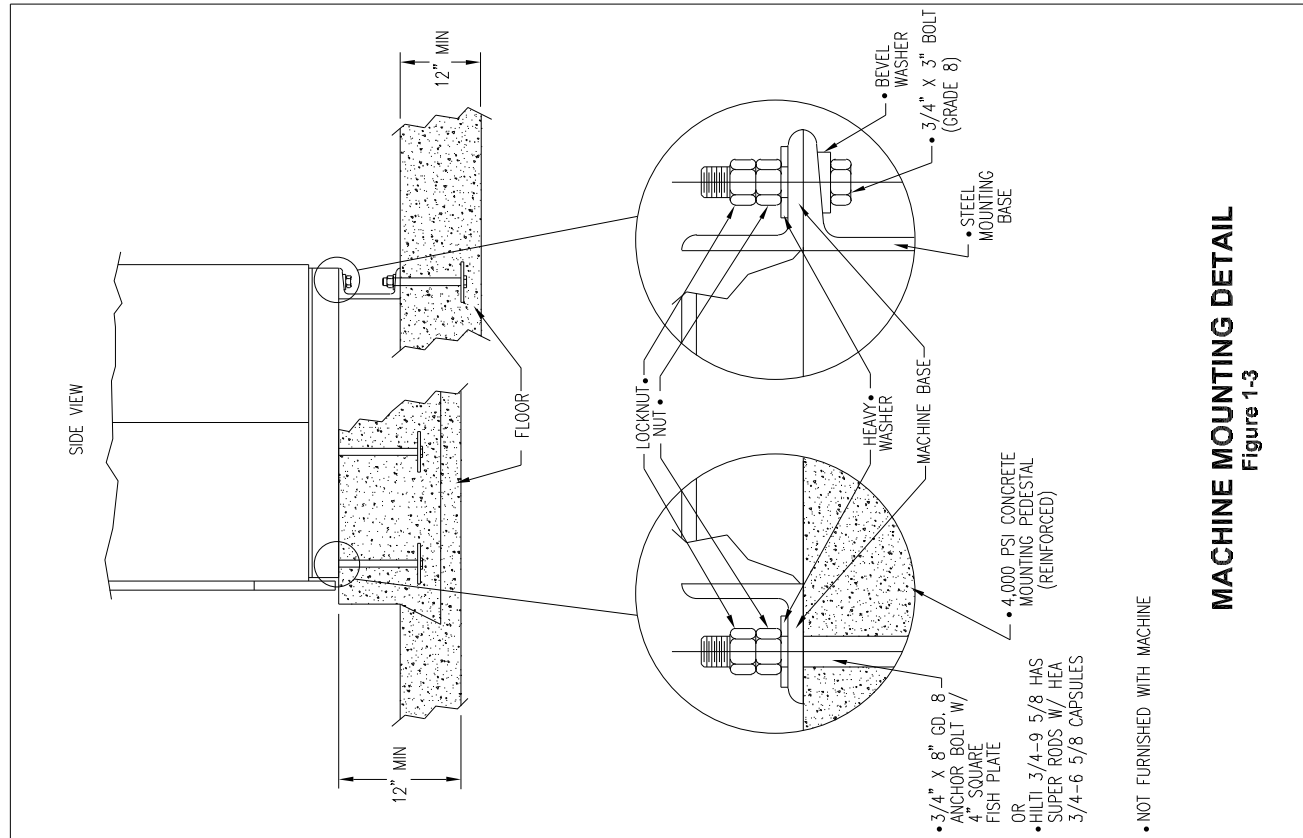

3/4" X 8" GD. 8 BOLTS  
HEADED BY 4" SQ. FISH PLATE OR EQUIV.  
OR  
'HILTI' ADHESIVE ANCHORING SYSTEM.  
USE HILTI 'HEA' 3/4-6 5/8 ADHESIVE CAPSULES  
AND HILTI 'HAS' SUPER RODS 3/4-9 5/8  
FOR MORE INFORMATION CALL  
HILTI CUSTOMER SERVICE  
1-800-879-8000

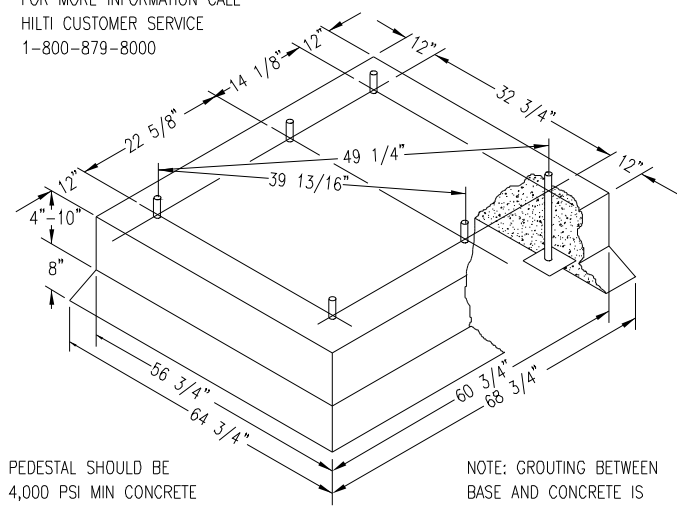

**CONCRETE PEDESTAL MOUNTING**

Figure 1-1

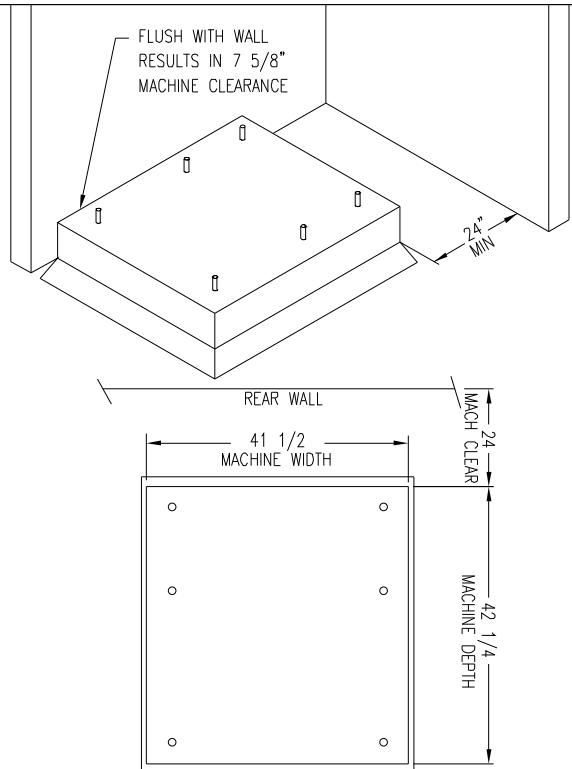

**FLOOR OUTLINE**

Figure 1-2

Notes section with horizontal lines for writing.

---

# Section 2:

## Machine Installation & Operating Instructions

---

## Installation & Operation

**All washers must be installed in accordance with all local, state and national building, electrical, and plumbing codes in effect in the area.**

### Foundation Requirements

The washer must be securely bolted to a substantial concrete floor, or mounted upon a suitable base which is in turn securely bolted to a substantial concrete floor. Care must be stressed with all foundation work to insure a stable unit, eliminating vibration. All installations must be made on sound concrete floors. See mounting dimensions for each model being installed.

### Mounting

A concrete pad or steel base which elevates the machine 4 to 6 inches above the floor level. To provide easy access to the loading door, it is recommended to allow a minimum of 24" of clearance behind the rear of the machine for service as is shown. Dexter highly recommends the use of a dry expansion grout mix.

### Proper Machine Grout Installation

Grout should be installed between base (if used) and concrete floor on all side rails and crossmembers. If using a base you should grout between base top and machine frame and all side rails and crossmembers. (Grouting between the machine base and the floor is absolutely required for all 200G Express Models)

### Mounting Holes

See mounting dimensions for the machine model you are installing in previous section. They also show a typical concrete pad arrangement. It is highly recommended that you use all mounting holes supplied with each model. Note: Mounting bolts should be checked frequently to insure that they remain tight. The machine should be checked with a spinning load to be sure there is no unusual vibration or movement between the machine and the base or floor. Please note: Machine grouting is highly recommended as grouting insures stability and longevity.

### Plumbing

Water supply hoses are furnished with each machine. The threaded connections on the hoses are standard garden hose type thread. Separate hot and cold water lines with shut off valves or faucets for inlet hose connections must be provided, maintaining 30 to 120 p.s.i. water flow pressure. Maximum water temperature is 180 degrees.

### Drain

The drain outlet tube at the rear of the machine is 3" in outside diameter on models T-400, T450, & T-600. The drain outlet tube at the rear of the machine is 2 1/4" outside diameter on a T-300 and T350 models. All Drains are gravity Drain. Adequate fall must be maintained for proper drainage.

### Protective Film

The machine may have protective adhesive film on the front escutcheon area and the front and side stainless steel panels. The film may be peeled off before putting the machine into service.

### Electrical

Dexter single/three-phase 208-240VAC 60 Hz washing machines are intended to be permanently installed appliances. No power cord is provided. The machine should be connected to an individual branch circuit not shared by lighting or other equipment. The connection should be sheathed in liquid tight flexible conduit, or equivalent, with conductors of the proper size and insulation. A qualified technician should make such connections in accordance with the wiring diagram.

T-300 WCAD20KCS-10 model (1 phase 120 volts) washers are equipped with an electrical cord with a 3 prong grounded plug. A U.L. approved receptacle, which has been properly grounded in accordance with local electrical codes must be used with the machine. Each unit should be connected to an individual branch circuit not shared by lighting or other equipment. Conductors of the proper size and insulation (suggested size below) should be used.

### To Make Electrical Connections

Disconnect all power to the washer. Remove screw and lift out the cover located in the upper left corner of the machine (as viewed from the back).

- If power is 208-240-3PH-60Hz, connect L1, L2, L3 and ground. If there is a high leg it must be connected to L3. It is highly recommended to use a TVSS.
- If power is 208-240-1PH-60Hz, connect L1, L2 and Ground. If power is 120 -1PH-60Hz. Use a UL approved receptacle with proper external ground.

NOTE: It is important that the grounding screw next to the power terminal block TB-1 be connected to a good external ground.

### Controls Transformer

The controls transformer is located inside the control trough and steps a range of 208 to 240 volts down to 115 volts. There are two terminals on the controls transformer for the primary (incoming) power. Use the terminal marked "208V" for power supplies between 200 and 215 volts. Use the terminal marked "230V" for power supplies between 216 and 240 volts.

NOTE: transformer must be set at proper tap for proper operation.

## Electrical Connections

Electrical power connections are made to the small terminal block located in the rear of the control trough. The terminal block is accessed by opening the top panel of the machine.

- 1 Phase or 3 Phase connections
- 208-240 volts, 60 Hz.
- 3 wire plus ground
- Suggested Minimum Wire Size -- 12 Ga.

### Fusing Requirements:

Dual element time delay fuse or equivalent breaker of amperage specified below.

- 1 Phase or 3 Phase 20 amp
- WCAD50SZ, WCAD-60, WCAD60SZ, WCAD-80, WCAD90SZ

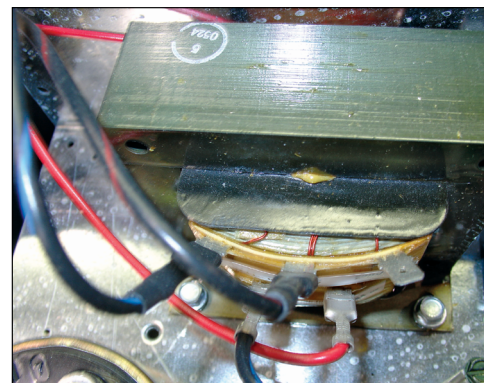
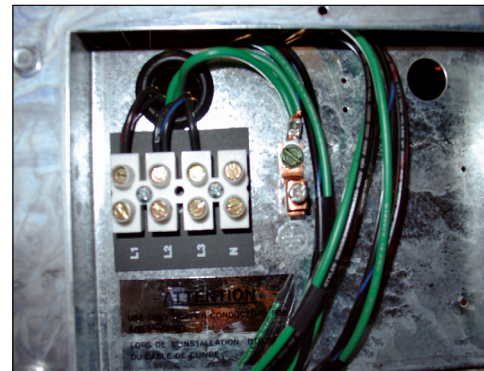

Rotation in extract as viewed through glass door at front of washer models WCAD-50sz,WCAD-60,WCAD-60sz,WCAD-80,WCAD90sz will be counter- clockwise.



# WARNING

**Always disconnect electrical power to the machine before performing any adjustments or service.**

## Emergency Stop / Safety Door Lock

This machine is equipped with a Safety Door Lock that locks the door closed from when the cycle is started until the cycle is complete. The door lock prevents opening the door for up to 3 minutes if the power is interrupted during the cycle.



The Emergency Stop button pauses the washer and allows the door to be opened during the cycle after the Safety Door Lock releases. When the Emergency Stop button is pressed an alarm will sound and the display will begin counting down from "3". If the button is released before 3 seconds elapse, the alarm will stop and the cycle will continue normally. If the Emergency Stop is held down for 3 seconds, the display will count down to "0" and the washer will begin stopping movement and water flow and begin draining water from inside the washer. Though the machine may stop wash movement quickly, it may take up to 3 minutes for the door to unlock. During that time the alarm will continue to sound. When the alarm stops, the door may be opened. The washer may be restarted by closing and latching the door, and pressing the Start button. If the washer was stopped during final extract, the cycle will be ended. If the washer is stopped for more than 1 hour, the cycle will be terminated. If the emergency stop is triggered a second time during the cycle, the cycle will be terminated.

## Operating Instructions

### Microprocessor

Prior to operation, the micro computer should be set to display the amount of vend price being offered and the cycle to be given to the user. NOTE: Should a power loss occur during cycle and when power returns, P U S H will be displayed in window and customer must push the START button to continue the cycle.

### Starting the Washer

- Load the clothes loosely in the cylinder and latch the door securely. Be sure clothing does not get caught between the door gasket and tub front when closing the door.
- Pour low-sudsing powdered detergent in the amount shown below into the detergent dispenser on top of the machine. Rinse conditioners may also be added to the dispenser. The correct location is shown on the dispenser lid.

NOTE: To close the door the handle must be in the horizontal position and then moved to the vertical position. After moving the door to the closed position, the handle must be turned down to the vertical position to latch the door for machine operation.

- Using the TEMPERATURE SELECT buttons on the front, select the desired temperature. If temperature pricing is being used you will display price changes as you push the desired temperature selection. This selection must be made before inserting coins to satisfy temperature price selected. If coins or value are added after extended plus cycle vend price is met it will be lost without credit. If water temperature pricing feature is active and vend price met and machine started the customer

may change temperature selections of equal to or lower priced temperature selections already inserted into machine.

- D. Insert coins, tokens or activate card reader to meet displayed vending price. The washer will start, the display will read PUSH and the green "on" led will glow. The green start pushbutton must be pushed to start cycle time countdown and machine starting to run. "Door" will display if loading door is not closed and handle locked.
- E. If utilizing ADD PLUS CYCLE \$.000 option The front display will scroll, ADD PLUS CYCLE .25(example),amount to be added. User will have 1 minute to insert proper amount to activate this option.
- F. At the correct time in the wash bath cycle the green "ADD BLEACH" light will come on indicating the time and showing a diagram of the location for adding bleach if desired. The timing is 2 1/2 minutes after start of wash bath the light will come on and stay on for 2 1/2 minutes or end of wash bath .

**End of Cycle**

When the cycle is completed, the end of cycle buzzer will sound and the "on" light will go off. The loading door can now be opened by turning the door handle to the indicated position and pulling. Leave the clothes door open when the machine is not in use. Also, at the end of cycle the display will reset to the original amount required to start.

**Detergent Measurements By Washer Model**

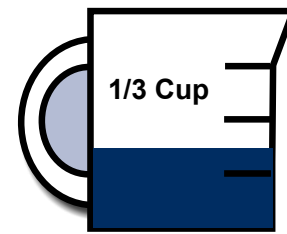

Maxi Load T-750 Washer

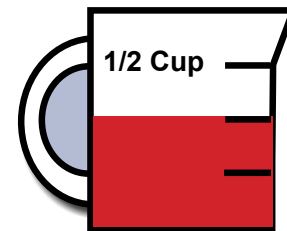

Mega Load T-900 Washer

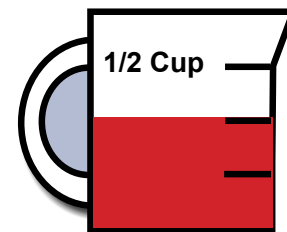

Mega Load T-950 Washer

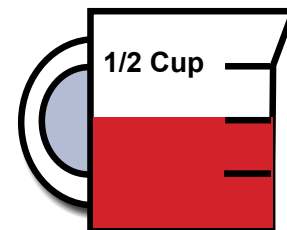

Magnum Load T-1200 Washer

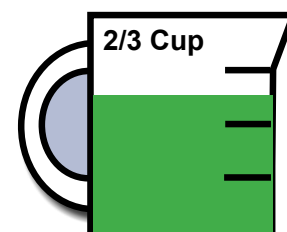

Magnum Load T-1450 Washer

**TRANSIENT VOLTAGE SURGE SUPPRESSORS**

Like most electrical equipment your new machine can be damaged or have its life shortened by voltage surges due to lightning strikes which are not covered by factory warranty. Local power distribution problems also can be detrimental to the life of electrical components. We recommend the installation of transient voltage surge suppressors for your new equipment. These devices may be placed at the power supply panel for the complete installation and don't require an individual device for each machine.

These surge protectors help to protect equipment from large spikes and also from small ongoing spikes in the power that occur on a day to day basis. These smaller surges can shorten overall life of electrical components of all types and cause their failure at a later date. Although they can't protect against all events, these protective devices have a good reputation for significantly lengthening the useful life of electronic components.

Electronic Components are helped to have a longer useful life when they are supplied with the clean stable electrical power they like.

We are including the following names and links to a few suppliers of these devices for those who don't currently have a source.

MANUFACTURER	LINK
MCG Surge Protection	<a href="http://mcgsurge.com">mcgsurge.com</a>
Eaton Corporation	<a href="http://eaton.com/us/en-us">eaton.com/us/en-us</a>
Schneider Electric	<a href="http://se.com/us/en">se.com/us/en</a>
Asco Power Technologies	<a href="http://ascopower.com/us/en">ascopower.com/us/en</a>
Emerson Electric Co.	<a href="http://emerson.com/en-us">emerson.com/en-us</a>



# Section 3:

## Machine Programming Instructions

### Programming Instructions

Programming can be accomplished manually using the machine controls or by connecting to the machine control using a PDA (personal digital assistant). For instructions on using a PDA with this washer control, please contact your local Dexter distributor. Please read below for manual programming instructions.

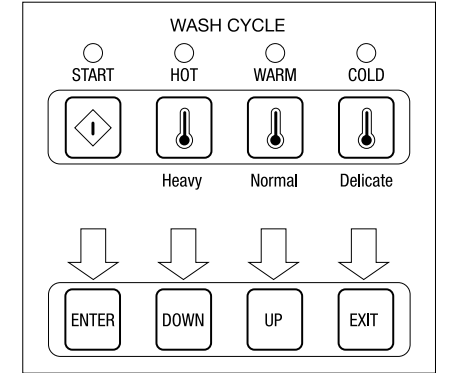

The washer has two levels of programming. The Washer Cycle Programming allows the owner complete access to the wash cycle parameters: add/remove a bath, bath times, spin times, water temperatures, etc. The Coin/Price Programming allows the owner to set the price for the washer features and the values of the coins. To enter the programming modes, the top of the washer must be unlocked and slid toward the back of the washer a few inches.

### Coin Price Programming

While the washer is in the Idle mode, push the Programming pushbutton on the controller. The Idle mode is when the washer is not running a cycle and the price of the bath is displayed. The Programming pushbutton is a very small button located on the upper center of the controller directly behind the display. There are seven stages in the Coin/Price Programming mode.

To step through to the desired stage, repeatedly push the Start button until the desired stage is blinking on the display. To exit the Coin/Price programming mode, push and hold the Cold temperature button for 5 seconds.

**#1 Right Coin:** The display will blink first an "r" indicating right coin and then a coin value (\$1.00: default). The display will blink back and forth between the "r" and the value. To change the value, use the Hot temperature button to decrease and the Warm temperature button to increase. The value will change in 1¢ steps. The range of values is from \$00.00 to \$99.99. When the desired right coin value is displayed, push Start button once to store the new value and a second time to move to the next Coin/Price programming step. To exit the Coin/Price programming mode, push the Cold temperature button for 5 seconds.

**#2 Left Coin:** The display will blink first a "L" indicating left coin and then a coin value (\$0.25– default). The display will blink back and forth between the "L" and the value. To change the value, use the Hot temperature button to decrease and the Warm temperature button to increase. The value will change in 1¢ steps. The range of values is from \$00.00 to \$99.99. When the desired left coin value is displayed, push the Start button once to store the new value and a second time to move to the next Coin/Price programming step. To exit the Coin/Price programming mode, push the Cold temperature button for 5 seconds.

**#3 Wash Price:** The display will blink first a "P" indicating wash price and then present wash price. The display will blink back and forth between the "P" and the price. To change the value, use the Hot temperature button to decrease and the Warm temperature button to increase. The value will change in 1¢ steps. The range of values is from \$00.00 to \$99.99. When the desired price is displayed, push the Start button once to store the new value and a second time to move to the next Coin/Price programming step. To exit the Coin/Price programming mode, push the Cold temperature button for 5 seconds. FREE START can be set by dropping the wash price to \$0.00.

### Water Temperature Pricing

The washer can be set for different levels of pricing for Cold, Warm and Hot water. The Cold water setting is considered as the base price, which is the normal washer cycle price.

**#4 Warm Water Price:** The next step in the pricing program is to set the additional price for Warm water usage. The display will blink first "CH P" indicating cold/hot water mix price and then "00.00". To change the value, use the Hot temperature button to decrease and the Warm temperature button to increase. The value will change in 1¢ steps. The range of values is from \$00.00 to \$99.99.

**NOTE:** To not use this feature, set the price to "00.00".

When the desired price is displayed, push the Start button once to store the new value and a second time to move to the next Coin/Price programming step. To exit the Coin/Price programming mode, push the Cold temperature button for 5 seconds.

**#5 Hot Water Price:** The next step in the pricing program is to set the additional price for Hot water usage. The display will blink first "H P" indicating hot water price and then "00.00". To change the value, use the Hot temperature button to decrease and the Warm temperature button to increase. The value will change in 1¢ steps. The range of values is from \$00.00 to \$99.99.

**NOTE:** To not use this feature, set the price to "00.00".

When the desired price is displayed, push the Start button once to store the new value and a second time to move to the next Coin/Price programming step. To exit the Coin/Price programming mode, push the Cold temperature button for 5 seconds. The Coin/Price programming mode will automatically exit and return to the Idle mode if no buttons are pushed for one minute.

**#6 Plus Cycle Price:** The next step in the programming sequence is the Plus Cycle feature. The Plus Cycle adds three (3) minutes of wash time to the wash bath only. The controller can be programmed to charge a fee for this or the feature can be turned off. The default setting is off (\$0.00).

The display will blink first a "PC P" indicating Plus Cycle price and then price (back and forth). To change the value, use the Hot temperature button to decrease and the Warm temperature button to increase. The value will change in 1¢ steps. The range of values is from \$00.01 to \$99.99. When the desired price is displayed, push the Start button once to store the new value and a second time to move to the next Coin/Price programming step. To exit the Coin/Price programming mode, push the Cold temperature button for 5 seconds.

**#7 Decimal Point:** The next step in the programming sequence is the Decimal Point. The display will blink "dP" and Default value is ON. The value "on" for enable or "off" for disable. Once a pushbutton is pressed, the display will stop blinking and show the decimal point value. The decimal point value will display and change with the Hot and Warm buttons. When desired value is reached press Start button.

---

## Wash Cycle Programming

To change a feature of the wash cycle, push and hold the Hot temperature button and then push the programming pushbutton on the controller. The Washer must be in the Idle mode to enter the Wash Cycle Programming mode. When entering the cycle programming mode the Bleach LED will start to blink and continue to blink as long as you are in the Cycle Programming mode. The display will show "C 0". This is the default cycle number.

**NOTE:** The washer can be returned to the factory default settings by holding the right Warm button and then pressing the left Warm button. The display must show "C 0" to do this. When the cycle default values are loaded, the washer will automatically exit the programming mode.

**NOTE:** The Wash Cycle programming mode will automatically exit and return to the Idle mode if no buttons are pushed for one minute.

To change the washer cycle, push the Hot temperature button once. The display will change to "C 1", indicating cycle one is selected. The temperature buttons are used to make changes to the program. In the program mode, these buttons will do as displayed in drawing below.

When the display shows "C 1", push Enter. The display will show "b " and the PreWash mode light will blink. Use the Up/Down buttons to move to the bath that will be changed. As Up/Down buttons are pushed, the next bath mode light turns on.

When the Up button is pushed, the lit bath mode changes from Prewash to Wash. With each additional push of the Up button, the lit bath mode changes from left to right: Prewash, Wash, Rinse and Final Rinse. As there are two possible Rinse bathes, for Rinse 1 the Rinse LED and the display changes to "b" in the left digit and "r1" in the two right hand digits. For Rinse2, the display changes to "b" in the left digit and "r2" in the two right hand digits. Note that the Spin light is not used. When the Down button is pushed, the lit bath mode changes from Prewash to Final Rinse, etc.. There is a wrap around feature on the display in both directions. When the desired bath mode light is on, push Start.

### Bath Cycle Time

The selected bath LED begins to blink. The display shows the letters "ct" in the left two digits and the bath cycle time in the right two digits. Again the up/down buttons change this value. The range is shown below. If zero time is entered, then the bath will be skipped and the program will return to the bath selection. When the desired cycle time is selected, push Start.

### Bath Water Temperature

The display shows the letter "t" in the left digit and the letters "CC" appear in the right two digits. This is the bath water temperature. The selection choices are shown below but for the coin washer the value is defaulted to CC. As it is not selectable with a coin washer, the owner pushes Start to continue.

### Bath Water Level

The display shows the letter "L" in the left digit and the letters "LO" appear in the right two digits. This is the bath water level. The selection choices are shown below but for the coin washer the value is defaulted to LO. As it is not selectable with a coin washer, the owner pushes Start to continue.

### Bath Delay Fill

The display shows the letters "dF" in the left two digits and the letter "t" appears in the right digit. This is the bath delay fill. The selections are "t" for decrementing bath time during the fill or "d" for delay the bath time until water level is reached. When the desired selection is made, push Start.

### Bath Spin

The display shows the letter "S" in the left digit and the bath spin time in the right two digits. Again the up/down buttons change this value. The range is shown below. When the desired spin time is selected, push Start. The display shows the letters "IS" in the left two digits and the injection selection appears in the right digit. For the coin washer the default value is "0" and cannot be changed. Push COLD.

The display will show "b" and the bath LED lights will stop blinking. Again use the up/down buttons change the bath selection. To exit the programming mode, push and hold COLD until price is displayed. The cycle will be stored when exiting the programming mode.

## Coin Washer Cycle Parameter Ranges

The range of each cycle parameter is shown below:

Bath Cycle Time "ct"
0 to 15 minutes for Prewash, Rinse1 and Rinse 3 to 15 minutes for Wash and Final Rinse. For the baths that can, if the time is set to zero, then that bath will be eliminated from the cycle.
Bath Water Temperature "t"
HH – hot, CH – warm, CC – cold, EE – no water. The owner can set the bath default. For the wash bath, the default is over ridden for that cycle by the customer when the temperature is selected.
Bath Water Level "L"
LO – low The owner can change the displayed value, but for a coinwasher only LO will be put into the cycle.
Bath Delay Fill "dF"
The selections are "d" for delay the bath time until water level is reached or "t" for decrement bath time during the fill.
Bath Spin Time "S"
0 to 10 minutes for Prewash, Wash, Rinse1 and Rinse2 1 to 10 minutes for Final Spin.
Bath "IS"
The owner can change the displayed value, but for a coin washer only 0 will be put into the cycle.

## Coin Washer Default Cycle (Preset at Factory)

The following table shows the complete details for the coin washer default cycle.

Bath	Bath Cycle Time (min.)	Water Temp.	Water Level*	Delay Fill	Spin Time (min.)	IS *
Prewash	0					
Wash	9	CH	LO	t	0	
Rinse 1	4	CC	LO	t	0	0
Rinse 2	0					
Final Rinse	5	CC	LO	t	4	0

\*NOTE: These default values are preset and cannot be changed.

## Rapid Advance Mode

To enter the Rapid Advance mode, push and hold the Cold water temperature button and then push the programming button on the controller. There will be no observed change to the washer or the display. The Rapid Advance mode can be entered from either the Idle mode or during the cycle. To rapid advance to the next step in the wash cycle, push both Start and Warm temperature buttons at the same time. The display will show an "Ad" (advance) in the display. The washer will advance to the next bath segment. The water will drain before the advance will occur.

To exit the Rapid Advance mode, push and hold the Cold temperature button for 5 seconds or more.

NOTES:

**Step 1:** When the Rapid Advance mode is used, the cycle time will no longer be correct.

**Step 2:** By skipping steps with rapid advance, the door may not open immediately at the end of the cycle.

## Main Control Printed Circuit Board

This control has a battery that allows memory retention in case of main power loss. The battery may need replacing if time of day options are not functioning properly.

### Remove power from machine and lockout safely.

Remove battery from socket on circuit board and reinstall new battery (#8612-001-001).

**CAUTION:** Do not soft reset this machine when installing new battery. This will reset internal clock and not allow re-startup of internal clock, possibly causing programming trouble.

## Section 4: Trouble Shooting

## Common Troubleshooting Solutions

Symptom	Probable Cause	Suggested Remedy
Machine does not start	Power Supply	Check these areas: Circuit breakers, Voltage, Power leads, Power connections. Is front display LED showing a dollar amount.
	Door Switch	Check for continuity through door switch when door is closed. If no continuity, adjust or replace door switch.
	Control Breaker or Fuse	Check 1.5 amp (T-1200. uses 2.5amp) breaker or fuse for continuity. If no continuity, replace breaker or fuse.
	Control Transformer	Check voltage output from control transformer for 120VAC. If voltage is incorrect, replace transformer.
	Coin Acceptor	Check coin switch to make sure coins trip switch and give continuity across switch when closed. If no continuity, adjust or replace switch.
	Check PCB board	Check all wire connections for sure contacts.
	Check wiring between PCB	Check data cable phone type connectors unplug and VFD and replug with power removed.
	Check Relay PCB	Check all wire connections for sure contact.
	Check Door Solenoid	Check that 120 v power is at solenoid after start button is pushed.
Machine will not accept and count coins	Coin Acceptor	Check coin acceptor switch for any type of blockage or damage. Clean, adjust or replace the acceptor.
	Power Supply	Check these areas: Circuit breakers, Voltage, Power leads, Power connection
	Door Closed Safety Switch	Check door closed switch at door hinge for proper operation.
	Door Handle Closed Switch	Check single door closed switch at left side of door handle to close when handle is vertical.
	Control Breaker or fuse	Check 1.5 amp (T-1200 uses 2.5 amp) breaker or fuse for continuity. If no continuity, replace breaker.
	Main PCB	Replace
Door does not lock	Check display for fault code	Does F1 show on the front of display. If yes follow tests described in fault code section.
	Door locking solenoid	Check to insure that solenoid is receiving 120VAC from main relay PCB. If it is, replace solenoid.
	Door Switch	Check for continuity through door latch switch when door closed. If no continuity, adjust or replace door switch.
Door will not open	Thermoactuator	Check to see if thermoactuator(s) and/or its mechanism is stuck or binding and not allowing the door lock solenoid to open. Check to be sure that the locking thermoactuator is not receiving 120VAC during the last 1 1/2 minutes of the cycle. Also check to see that the unlocking thermoactuator is receiving 120VAC during the last minute of the cycle. If the thermoactuators do not receive voltage at the correct times, change the timer. If the timing and voltage are correct, replace the thermoactuator.

Symptom	Probable Cause	Suggested Remedy
Door will not open	Door Rod	Check to see that door rod from solenoid to lock ass'y is long enough to allow lock ass'y to disengage. If not, adjust rod.
	Door Lock Solenoid	Check that door lock solenoid is not stuck closed. If stuck, replace solenoid.
No hot water in detergent dispenser	Water Valve Coil	Check coil continuity at terminals and replace if no continuity. 120 V power only on for 20 second in wash bath.
	Water Inlet	Check water inlet screens for blockage and clean screens if necessary.
	Water	Check to insure that water is turned on and operating.
	P-20 Wire Harness	Check black & white harness.
Symptom	Probable Cause	Suggested Remedy
Hot water does not enter tub in wash	Water Valve Coil	Check coil continuity at terminals and replace if no continuity. Check for 120 V power from main relay PCB
	Water Inlet	Check water inlet screens for blockage and clean if necessary screens
	Water	Check to insure that water is turned on and operating.
	Blk or Wht wire at main controller	Check black or white wires at Molex plug on PCB at main controller and at relay PCB.
	Pressure Switch	Check pressure switch continuity between terminals . If no continuity, check pressure switch hose for obstruction. If hose okay, change pressure switch.
No cold water to tub in wash	Water Valve Coil	Check coil continuity at terminals and replace if no continuity.
	Water Inlet Screens	Check water inlet screens for blockage and clean if necessary.
	Water	Check to insure that water is turned on and operating.
	Blk or whit wire at controller and main relay PCB	Check black or white wires at Molex plug on PCB at main controller and at relay PCB.
	Pressure Switch	Check pressure switch continuity between terminal contacts. If no continuity, check pressure switch hose for obstruction. If hose okay, change pressure switch.
Water comes in but level does not rise	Drain Valve (open)	Check these areas • Drain valve blockage • Drain valve motor and gear train. If power but drain valve does not close, replace valve. • Power to the drain valve. If no power to drain valve, check (brn/yel) circuit for power.
	Blk or whit wire at controller	Check black and white wires at molex plug on main PCB controller and at main relay PCB
Water does not flush softener compartment.	Water Valve Coil	Check coil continuity at terminals and replace if no continuity.
	Water Inlet Screens	Check water inlet screens for blockage and clean if necessary.
	Water	Check to insure that water is turned on and operating.

## Common Troubleshooting Solutions

Symptom	Probable Cause	Suggested Remedy
Water does not flush softener compartment.	Pressure Switch	Check pressure switch continuity between terminals. If no continuity, check pressure switch hose for obstruction. If hose okay, change pressure switch.
Water level too high	Pressure Switch	Check for blockage in pressure switch hose. Check for pressure switch opening circuit across terminals . Replace switch if contacts do not open.
Water drains slowly	Drain System	Check hoses and drain valve for blockage. Clean of inadequate size. if necessary. Check building drains for blockage
Machine does not turn	VFD	Check VFD by removing inspection panel and record any numbers or letters displayed. If no display turn power off to machine at breaker for 2 minutes and turn power back on to reset. If still no display replace VFD
Machine tumbles in one direction	VFD	Remove inspection cover at rear and record in only numbers or letters displayed. See fault code section for more info.
	VFD	Inspect yellow enable wires from main relay PCB and at VFD
Excessive vibration	Mounting System	Check these areas: • Strength of mounting structure, concrete or base. • Mounting bolts may be loose and need tightening.
	Drive Belt	Worn drive belt can cause vibration and noise.
	Loading	Note: Small loads contribute to out of balance loading and increase vibration.
Machine does not spin	Pressure Switch	Check pressure switch for continuity across terminals #21 & #22 indicating pressure switch has reset to the empty position. If no continuity, change pressure switch.
Machine starts and does not operate	VFD	Check yellow enable wires from relay PCB P13 & motor P14to VFD advances through cycle are connected. Check fault code on VFD before removing power from the drive. Check orange P-15 wire for signal from door switches.
Machine does not stop	Main PCB	Main PCB controls time cycle at end of cycle
	Braking Resistors	Check braking resistors for continuity. Verify ohms resistance by Molex.
Water leakage around loading door	Door Adjustment	Door may need adjustment due to abuse or wear. Check tightness around perimeter using a dollar bill. Adjust left to right tightness by shims at door lock or hinge side. It is important to center gasket to tub opening before tightening door to hinge bolts. Chalk may be used on tub front to show point of contact with tub. If gasket is deformed, worn, or damaged, replace. Refer to parts section for door gasket expander kit.

## Troubleshooting Machine Fault Errors

The following are descriptions of fault codes that will appear on the front of the washer. There is a chart format that shows what fault code that will be displayed at washer front. The codes displayed may or may not stop machine operation.  
PLEASE NOTE: CHECK DRIVE FAULT CODE BEFORE POWERING MACHINE DOWN!

Fault#	Description	Customer Action
<b>F1</b>	The door failed to close and lock or The door failed to remain locked during the cycle.	Check VFD fault code before turning off. Check to hear if door solenoid engaged. Turn off the power to the washer. Check wire connections to door /lock switches. Check wire connections from switches to controller. Check P-4 wire connections at PCB controller. Adjust the door lock mechanism. (See service manual)
<b>F2</b>	The washer tub does not fill with water within 7 minutes. The wash cycle will continue. The F 2 will flash three times, then wait for 30 seconds. The error will clear at the end of the cycle.	Turn off the power to the washer. Check the operation of the water valves. Check the incoming water pressure. Check for blocked or restricted water flow. Check to ensure the drain valve is functioning properly. This error will occur on 18# washers when water level is set for high (the pressure switch in 18# washer is only one level).
<b>F3</b>	Memory error in controller. The memory checksum is wrong.	Check VFD fault code before turning off power. Try to clear the fault with the Palm. Try a soft Reset of the controller with the white button. If problem. Replace PCB controller.
<b>F4</b>	Washer controller communication error	Check VFD fault code before turning off power. Try the data cable first. Move around cable and remove any side loading tension from data cable connector ends. Check connection P25/24/23 to P15. Turn power back on to the washer. If the problem returns, replace the PCB washer controller.
<b>F5</b>	Pressure Switch error (only OPL) - when the high level sensor indicates full but the lower one indicates empty. The wash cycle will continue. The F 5 will flash three times, then wait for 30 seconds. The error will clear at the end of the cycle.	Check VFD fault code before turning off power. Check the pressure switch.(Ohm out contacts). Check pressure switch connections to ensure they are all making good contact. Check the Molex type harness connector to ensure no wire been pushed out of the Molex type housing that it is shorting or not connecting.
<b>F6</b>	Wrong washer size for drive type.	Check VFD fault code before turning off power. If the controller was installed in a different size machine before being installed in this machine, a problem can occur. If someone has been doing repairs on the washer, check for the correct size drive. It can also be caused by pressure switch harness. Check to ensure the correct harness in installed. The control can be reset by holding program button on controller during startup (soft reset). Check orange wire at Molex connector on controller coming from pressure switch or replace pressure switch harness.

Fault#	Description	Customer Action
<b>F7</b>	Wrong size drive installed	Check VFD fault code before turning off power. Check to ensure all the harnesses are properly connected to the controller. Check to ensure the VFD drive horsepower is proper for this size of washer. The control can be reset by holding program button on controller during startup (soft reset) Check orange wires at molex connector on controller coming from pressure switch.
<b>F8</b>	The washer tub does not empty within 7 minutes. The wash cycle will continue. The F 8 will flash three times, then wait for 30 seconds. The error will clear at the end of the cycle.	Check VFD fault code before turning off power. Check to ensure the drain valve is operating properly (slow drain has potential to cause this code). Check to ensure the pressure switch tube is clear of any blockage, and the pressure switch is operating properly. Check the pressure switch harness.
<b>F9</b>	The washer tub does not reach the spin target frequency within 150 seconds. The wash cycle will continue. The F9 will flash three times, then wait for 30 seconds. The error will clear at the end of the cycle.	Check VFD fault code before turning off power. Check to ensure the drain valve is operating properly (slow drain has potential to cause this code). Check to ensure the pressure switch tube is clear of any blockage, and the pressure switch is operating properly. Check the pressure switch harness.
<b>F10</b>	After a spin the washer tub does not stop within 150 seconds.	Check VFD fault code before turning off power. Inspect the braking resistors and measure the resistance. Check connecting wiring from braking resistor to the drive mounted in the top of the washer. Reset the drive and try again. Possibly incorrectly programmed drive.
<b>F11</b>	The drive size setting has changed.	Check VFD fault code before turning off power. Check to ensure all the harnesses are properly connected to the controller. Check to ensure the drive horsepower is proper for this size of washer. If no one has worked on machine very recently then PCB controller or VFD may need to be replaced. Do a soft reset before and after either VFD replaced.
<b>F12</b>	Washer controller internal error	Check VFD fault code before turning off power. Turn off the power to the washer. Wait one to two minute. Turn on the power to the washer. If problem reappears, contact your Dexter Authorized Representative.

Fault#	Description	Customer Action
<b>F13</b>	The variable frequency drive (VFD) and the washer computer are not communicating.	<p>Check the data communication cable between the washer computer and the variable frequency drive (VFD).</p> <p><b>Step 1:</b> Make sure the cable did not become unplugged during operation.</p> <p><b>Step 2:</b> Make sure that the cable is not being pulled sideways at either the washer controller, or the VFD, plug end. If both ends of the communications cable are plugged in the washer computer and VFD and there is no tension on the communications cable pulling it from side to side, then replace the cable.</p> <p><b>Step 3:</b> Inspect both female connection points at PCB controller and at VFD. These may need replacement if they cannot be reset.</p>
<b>F14</b>	Over-current on the drive or motor.	<p><b>Step 1:</b> Check to make sure the washer cylinder turns freely by hand. If it turns freely, continue to step 2. If it does not, remove the belt and see if the motor turns freely by hand. If the motor turns freely, then check for obstructions in the cylinder or check the bearings. If the motor does not turn freely, replace the motor.</p> <p><b>Step 2:</b> Check the motor wires for a short circuit between leads. If there are motor leads that have conductors touching, separate them and insulate them. If the wires are broken, splice them together or replace the motor.</p> <p><b>Step 3:</b> Check braking resistors to see if they measure the correct resistance. If a resistor does not measure the proper value, replace it.</p>
<b>F15</b>	The variable frequency drive (VFD) senses that the internal voltage is too high. The source of the problem can originate from two different areas. Area 1: The input voltage can be too high, or there may be a high level of electrical noise. Area 2: The motor can be generating a voltage that is acting like an input to the VFD output motor terminals.	<p><b>Step 1:</b> Measure the supply voltage to the VFD on the L1, L2 (or N), and L3 (if connected to three phase power). the supply voltage should be from 187 to 264 VAC or 108 to 132 VAC for a 120 VAC VFD. Also make sure the supply wires on L1, L2 (or N) and L3 (if connected to three phase power are securely connected.</p> <p><b>Step 2:</b> Check the braking resistor connections at the VFD. The terminal screws should be tight. Once of the braking resistor wires should be connected to terminal B2.</p> <p><b>Step 3:</b> Measure each braking resistor separately to make sure they are the correct resistance. (200 for 1 and 2 Hp VFD and 160 for 3 Hp VFD).</p> <p><b>Step 4:</b> If you have a 240 VAC, high leg voltage supply, try disconnecting the high leg. If this cures the problem, either leave the high leg disconnected, connect a transient voltage surge suppressor (with some form of filtering) at the voltage supply panel, connect a line choke on the high leg or install a VFD filter.</p>

Fault#	Description	Customer Action
<b>F16</b>	The temperature sensor inside of the variable frequency drive detects that the internal temperature is too high.	<b>Step 1:</b> Make sure the cooling fins on the VFD heatsink and the ventilation louvers on the VFD cooling fan cover are clean. <b>Step 2:</b> Start a washer cycle and make sure the VFD cooling fan operates after the cylinder starts turning.
<b>F17</b>	Overload of the drive or motor	(Check drive fault code before powering down). Check the washer motor to ensure it turns freely. Check the wiring for loose connections to the drive and motor. Measure the braking resistor values. Check for damaged motor wires. Check V-Belt tension and adjust to 1" deflection at center. Check braking resistors.
<b>F18</b>	Ground Fault to the drive	Check VFD fault code before turning off power. Check the wiring connections to the drive and motor. Check the ground wiring of the drive, motor and incoming connection to ensure a proper ground is present. Check for damaged motor wires.
<b>F19</b>	Low Voltage to the drive	Check VFD fault code before turning off power. Turn the power off to the washer. Check the wiring connections to the drive and motor. If no problem is observed, turn on power to the washer and test. (See Note) Measure the incoming line voltage.
<b>F20</b>	Internal drive error	Check VFD fault code before turning off power. Turn the power off to the washer. Wait one minute. Turn the power on to the washer. If problem reappears, contact your Dexter representative.
<b>F21</b>	Data error on communications between the controller and drive Internal drive error # 32. This error also has CEXX errors associated with it that are presented on the drive display.	The CE errors are communications errors. Data Cable noise can cause the majority of these errors. Check VFD fault code before turning off power. Check the data cable between the controller and the drive. Replace data cable if it appears damaged and fault appears again. Please note that this fault will occur if you turned main power off and on to quickly. (See Note below)
<p><b>Warning codes F22 - F28: These codes indicate that a component (VFD, relay PCB, injection relay PCB, water valve) has been replaced, added, or removed and you will need to <u>soft reset</u> the PCB controller board to reset the main controller to operate properly.</b></p>		
Fault#	Description	Customer Action
<b>F22</b>	MS300 Drive Conversion Only	Retighten the screw down connections on the lower terminal bar of the VFD for DC1, B1, and B2. Check the wire connections on B1 and B2 for Braking Resistors.
<b>F23</b>	VFD has been replaced, disconnected, or removed.	Soft reset control.
<b>F24</b>	Injection relay PCB has been removed or loose connection.	Soft reset control.

<b>F25</b>	Optional water valve PCB removed or water valve has been replaced .	Soft reset control.
<b>F26</b>	VFD unit has been added or loose connection.	Soft reset control.
<b>F27</b>	Injection relay PCB has been added to machine or loose connection.	Soft reset control.
<b>F28</b>	Optional water valve PCB has been added or loose connection	Soft reset control.

## Drive Motor Inverter Type Motor-Winding Resistance Chart

### 50lb Express, 60lb Express, 80lb A-Series Washer

Motor	Winding	Wire #	Resistance	
			Minimum	Maximum
1ph or 3ph 60hzMain (wash & spin) Dexter #9376-329-001 Marathon		T1 & T2	0.94	1.097
		T2 & T3	0.94	1.097
		T1 & T3	0.94	1.097
Dexter #9376-298-001 A.O. Smith		T1 & T2	1.05	1.16
		T2 & T3	1.05	1.16
		T1 & T3	1.05	1.16

### 60lb A-Series Washer

Motor	Winding	Wire #	Resistance	
			Minimum	Maximum
1ph or 3ph 60hzMain (wash & spin) Dexter #9376-308-001 Marathon		T1 & T2	2.4	2.8
		T2 & T3	2.4	2.8
		T1 & T3	2.4	2.8

**NOTE:** Resistance values are measured at the stator. Values at the end of the motor wiring harness may be slightly higher.

### 90lb A-Series Express Washer

Motor	Winding	Wire #	Resistance	
			Minimum	Maximum
90lb 1ph or 3ph 60hz Main (wash & spin) Dexter #9376-326-001 Marathon		T1 & T2	.438	.505
		T2 & T3	.438	.505
		T1 & T3	.438	.505

**NOTE:** Resistance values are measured at the stator. Values at the end of the motor wiring harness may be slightly higher.

## Variable Frequency Drive Control Digital Readout Faults

Fault#	Description	Customer Action
<b>CE1</b>	VFD received an illegal command. Possible controller problem	Reset drive.
<b>CE2</b>	Illegal data address, VFD received an address not available to the controller.	Reset drive.
<b>CE3</b>	Illegal data value received at VFD. Possible controller problem.	Reset drive.
<b>CE4</b>	VFD unable to perform the requested action. Possible controller problem.	Reset drive.
<b>CE6</b>	Time frame between commands is too short. Possible controller problem.	Reset drive.
<b>CE9</b>	Internal checksum error. VFD problem.	Reset drive.
<b>CE10</b>	Watch dog timer. Command not received from the controller every 6 seconds	Reset drive.
<b>CE11</b>	Frame error. Possible Baud rate issues between VFD and controller	Reset drive.
<b>CE12</b>	Command message is too short. Possible controller problem	Reset drive.
<b>CE13</b>	Command message is too long. Possible controller problem	Reset drive.
<b>CE14</b>	Command message includes unused characters. Possible controller problem.	Reset drive.

Normal operation of the VFD: VFD display shows operating frequency first very quickly then changes to F0.0 at time power is returned. This will stay displayed until the VFD receives a command from main control PCB. (Pushing start button) A CE-10 fault will display at drive if improper communication between PCB and VFD has occurred.

**Note:** Resetting a fault code on front of washer: Turn the power off to machine (machine will need to remain off for up to three minutes ).

SOFT RESET : is accomplished by pushing the white button located on the Main controller PCB board and simultaneously turning power on to machine. This will reset main controller to factory default settings.

Please record any modified information that has been inserted in memory before attempting to Soft Reset the PCB.

CE5, CE7 and CE8—Reserved by DELTA

---

# Section 5:

## Machine Service Procedures

---

### Top Panel Removal

- Step 1:** Remove 4 screws that hold detergent dispenser to top panel. (for T750)
- Step 2:** Unlock top panel lock.
- Step 3:** Raise top panel, slide to the rear to release from back clips and lift off.

### Front Panel Removal

- Step 1:** Remove the loading door lower leaf hinge and lift the door from the top post of the hinge.
- Step 2:** Remove 2 screws between front panel top and front (located behind control panel).
- Step 2:** Remove the two screws in the middle of the front panel.
- Step 3:** Pull panel out at the bottom to about a 45 degree angle to detach the top lip and remove.

### Back Panel Removal

- Step 1:** Remove all screws holding back panel in position except the bottom row.
- Step 2:** The bottom row of screws are slotted and only need to be loosened and to lift off panel.

**NOTE:** The back panel is not only a safety requirement but also contributes to the rigidity of the cabinet.

### Drain Valve Access

For access to drain valve, remove lower service panel. The drain valve is a ball type and is powered closed by the drain valve motor. It is mounted under the washer tub on the left side. It is spring loaded open. If power is interrupted to the washer, the motor releases the sealing ball, allowing the drive spring to open the valve. With the valve open, all water in the washer will drain out.

### Drain Valve Cleaning

- Step 1:** Loosen the clamp on the tub hose at the drain valve end and remove the hose from the drain valve.
- Step 2:** Loosen the drain hose clamp on the back of the drain valve. Remove two drain valve mounting racket screws from the frame of the washer.
- Step 3:** **Disconnect brown/yellow & blue wire connection at clear connector.**
- Step 4:** Remove the drain valve and bracket assembly. Unplug the wiring after the drain valve is removed from the washer.

### Detergent Dispenser (T-750)

Remove top panel to access dispenser. (see Removing Top Panel) Detergent is flushed from the front of the compartment and fabric softener is flushed from the back. There will be a small amount of water left in the fabric softener compartment after each use.

### Vacuum Breaker (also called an air gap)

In the left rear of the cabinet is the vacuum breaker. It guides the water to the tub and dispenser and prevents a back flow of water.

## Water Valves

Remove top panel to access water valves. (see Removing Top Panel) The two dual outlet water and/or single coil valves are mounted to the rear channel with two screws each. Always check inlet screens to be sure that they are clean. Disassembly requires the removal of two solenoid screws and three valve body screws. Below the solenoid coil is a solenoid guide, armature, armature spring and diaphragm. All valve parts are available individually or as a complete unit.

## Door Lock Assembly Operation

After loading the clothing, the door should be closed and latched. The locking cam on the door contacts the latching switch actuator which closes the latching switch. The specified number of coins should now be added to start the washer. The solenoid pulls up on the locking pawl by use of a linkage rod. The locking pawl has two jobs. The first is to lock the door. This is accomplished by blocking the locking cam on the door so that it can't rotate to unlock. The second job is to close the two piggyback lock sensing switches. These switches control power to all of the controls. If the door unlocks for any reason, these two switches will stop the machine. When the door handle is 1/4 to 1/2 of an inch from its fully closed position, the latching switch should close. The two piggyback lock sensing switches should be open when the door is unlocked and should be closed when the door is locked.

## Accessing the Door Lock Assembly

After removing the front panel and masking ring, the door lock assembly can now be accessed.

## Adjustment for Door Lock Assembly

The latching switch and the piggyback lock sensing switches all have slotted mounting for easy adjustment.

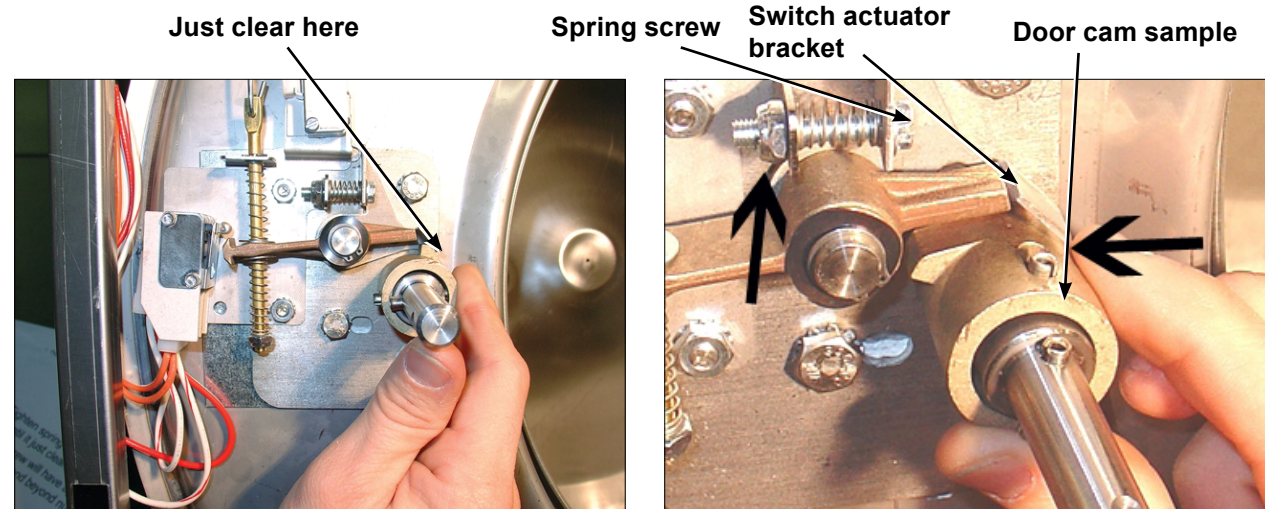

**Step 1:** Set door cam over pin. Here you can see the door cam away from the door lock assembly.

**Step 2:** Tighten spring screw on switch actuator bracket arm until it just clears cam OD. at base of door lock assembly.

**Adjustment to this bracket usually is not necessary as next step is used more in field.**

Flat blade screw on door switch latching

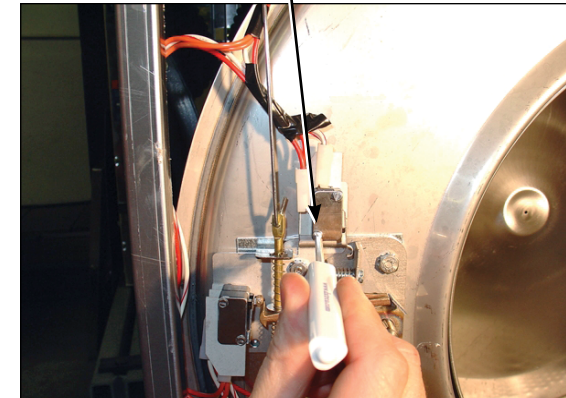

**Step 3:** With switch actuator bracket adjusted you will now need to adjust single switch by loosening 2 flat blade screws and allowing swivel of switch. Move switch towards above bracket until it actuates. Now tighten flat blade screws. Use a .040 thickness guage to insert between bracket and switch and the switch should close and open again upon removal of thickness guage.

Door cam check position

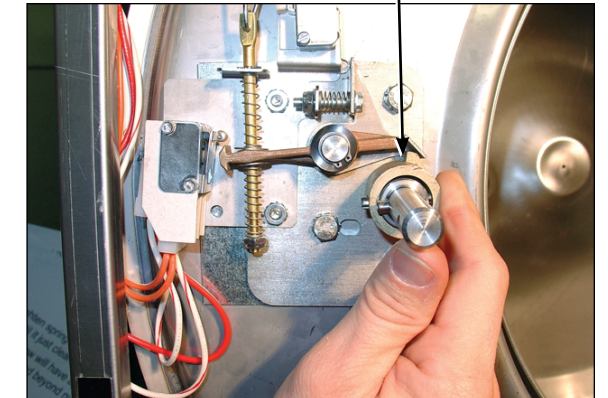

**Step 4:** Check for switch actuation at partial turn of cam as in operation above. Door handle goes from horizontal to six o'clock vertical.

Door lock rod Locking pawl blocking

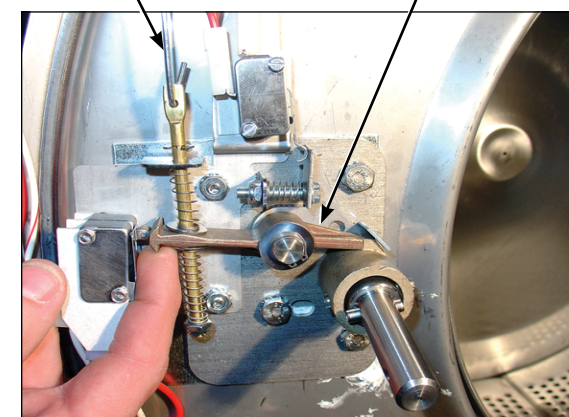

**Step 5:** Check that lock pawl arm swings to cam lobe to lock position.

Adjustment screw for (piggyback switches)

Top of flat end of locking pawl.

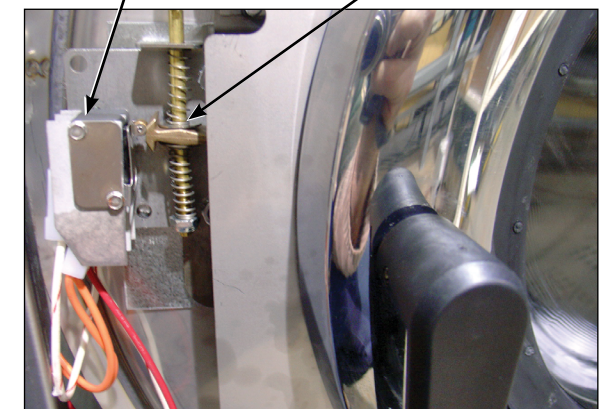

**Step 6:** The lock stacked switches (piggyback) must be adjusted as door lock solonoid pulls up on door rod and locking pawl is now blocking door cam from turning and is in full up position. The stacked swtiches (piggyback) have a single actuator arm and it must actuate when single actuator roller wheel rolls to flat side of locking pawl. You will also notice a .040 gap between actuator arm and switch bodies.

Note: Both stacked switches must operate together!

## Adjusting the Loading Door

The door can be adjusted by changing the number of shims behind the door hinge and the door lock assembly. The vertical fit of the door to the tub can be altered by loosening the door hinge bolts and raising or lowering the door before retightening. It is important for the door to be centered on the tub front. By chalking the front of the tub and closing the door to transfer that line to the gasket, the centering can be evaluated. It is also important for door pressure to be similar around the door perimeter. Door pressure can be evaluated by inserting a dollar bill in several positions and tugging on it. See Parts Section for kit to increase door sealing pressure.

### Loading Door Removal

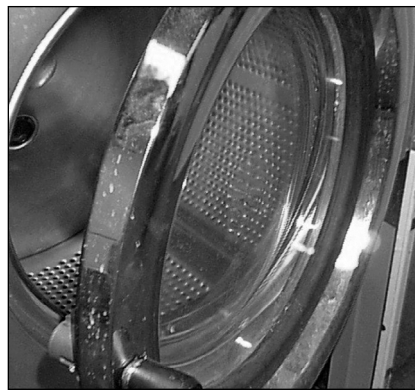

**Step 1:** Support door to prevent dropping.



**Step 2:** Remove 2 bolts holding the lower leaf hinge and set door off.

### Loading Door Hinge Removal

**Step 1:** First remove loading door, front panel, and trim ring.



**Step 2:** Remove 3 screws holding door hinge. Shims may be present between hinge and tub front. The number may be increased or decreased to adjust right side door pressure.

**NOTE:**  
Door hinge mounting bolts penetrate tub front and require silicone sealer applied to holes when reinstalling.

## Loading Door Disassembly

**Step 1:** Remove the loading door as outlined above. Lay the door on a flat surface with the glass down.

**Step 2:** While holding down on the door glass, lift up on the door ring and roll back the lip of the gasket with your fingers.

**Step 3:** Work all the way around the gasket and the glass is out.

## Loading Door Reassembly

**Step 1:** Lay the door ring face down on a flat surface. Start the glass into one side of the door gasket.

**Step 2:** Use one hand underneath to push the gasket out and the other hand on the top pulling the gasket in place.

**Step 3:** The front lip of the door gasket should be checked for proper seating.

## Control Panel Name Plate Decal

The name plate on washer front is adhesive backed.

## Control Panel Name Plate Removal

The name plate may be removed by simply peeling it off.

## Re-Installation of Name Plate

**Step 1:** Remove any remaining glue from the control panel.

**Step 2:** Before removing the paper backing from the name plate, check fit to the control panel. The program push buttons are the locating guides.

**Step 3:** Remove the paper backing from the right side of the name plate, position it on the panel and press right end into place. Peel the backing from the left end and press into place.

### Door Locking Solenoid (Original Models)

The door locking solenoid is powered shut with control voltage to lock the door and releases when voltage is removed. It is located in the left front corner of the washer.

### Door Locking Gear Motor Assembly (Newer Models)

The door locking gear motor is rotated shut with control voltage to lock the door and releases when voltage is removed. It is located in the left front corner of the washer. (Original locking solenoid models can be converted to the new assembly)

### Thermoactuators

The thermoactuators are a safety device that keeps the door from immediately unlocking if power is lost while the machine is operating. They are mounted under the door locking solenoid.

### Lock Thermoactuator

Control voltage is applied to the lock thermoactuator at the beginning of the cycle making it extend and block the door locking solenoid. This keeps the door locked for approximately two minutes after a power failure occurs. The lock thermoactuator does not delay the door opening at the end of a normal cycle.

### Unlock Thermoactuator

To insure that the lock thermoactuator has retracted by the end of the cycle, one minute prior to the end of the cycle, the unlock thermoactuator is powered with control voltage making it extend and unblock the door locking solenoid.

### Drive Belt Removal

Turn the drive belt(s) off the basket pulley first and then remove from the motor pulley.

Reverse this procedure for installation.

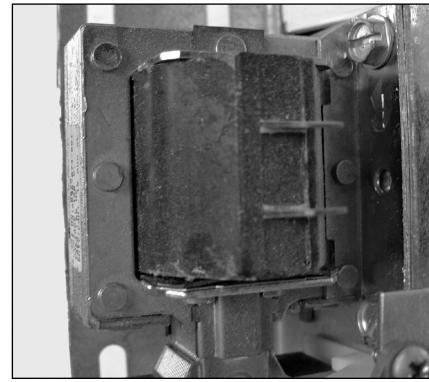

Door Lock Solenoid

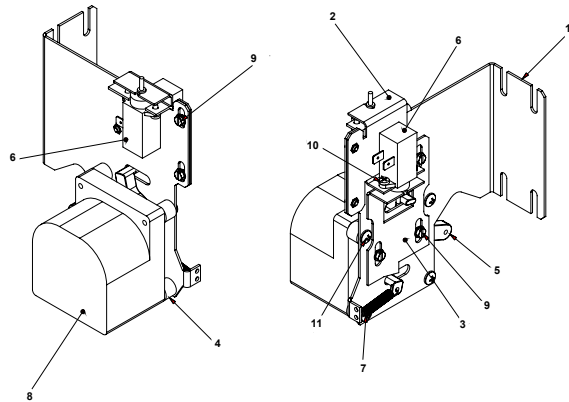

Door Lock Gear Motor

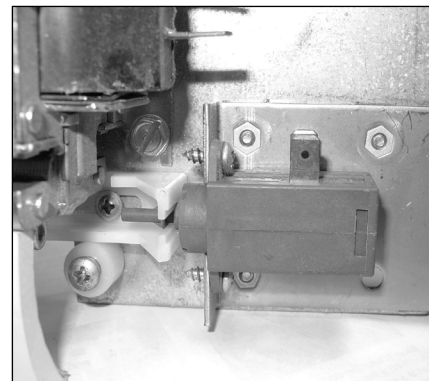

Thermoactuator

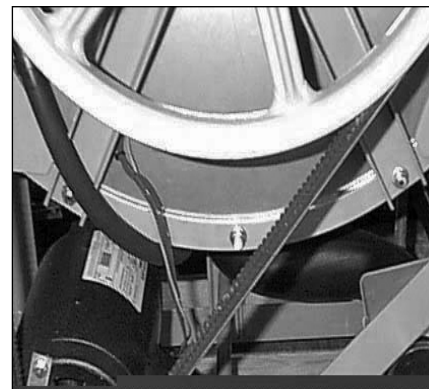

Drive Belt

### Cylinder

- Step 1:** Remove the top panel as described previously.
- Step 2:** Remove lower service panel as described previously.
- Step 3:** Remove front panel as described previously.
- Step 4:** Remove masking ring as described previously.
- Step 5:** Remove door lock assembly. (Leave wires & pull rod in place)
- Step 6:** Remove clothes door.
- Step 7:** Remove tub front clamp ring.
- Step 8:** Remove tub front. Use a flat screw driver to pry the tub front loose.
- Step 9:** Remove the rear access panel.
- Step 10:** Remove the drive belts.
- Step 11:** Remove drive pulley. Remove 3 retaining screws. Insert (3) 3/8 16 x 2" screws into the threaded removal holes. Alternately tighten these screws evenly to pull the pulley off.
- Step 12:** Remove pulley hub. Drive a flat screw driver into the slot in the hub and pull it from the shaft.
- Step 13:** Install cylinder puller. (Snap On part #CJ-84-C) Be sure to thread a 5/8-11 NC bolt into the end of the cylinder shaft to protect the threads. Push the basket out.

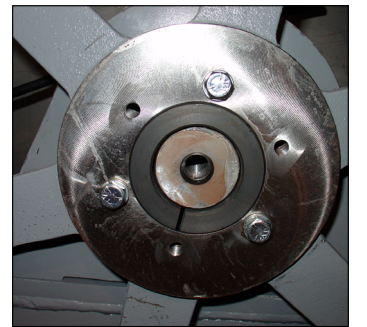
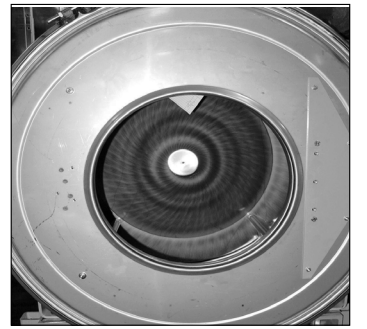

### Bearing Housing Assembly

#### Removal

- Step 1: Remove cylinder from washer (see Cylinder (basket) removal).
- Step 2: Remove 6 7/16" tub back to bearing housing cap screws.
- Step 3: Remove 6 3/4" bearing housing to frame bolts.
- Step 4: Remove bearing housing from frame.
- Step 5: Remove the retaining ring next to the front bearing.
- Step 6: The bearings are pressed into the housing and must be pressed back out.

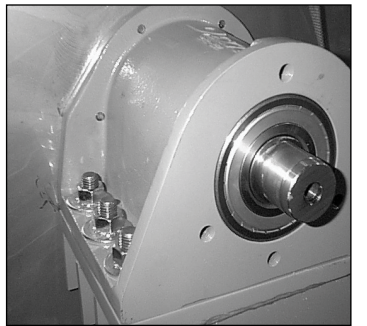

#### Reassembly

- Step 1: When installing new bearings into a bearing housing, first press the front (large) bearing into the housing until it bottoms and install the snap ring. With the bearing spacer in place, press the rear bearing in until the spacer is snug between the two bearings.

**NOTE:** If the tub-back water-seal mating ring has been moved it must be cleaned and resealed

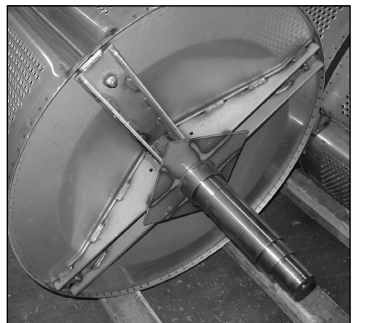

## Water Seals

### Replacement

- Step 1:** Remove cylinder from washer (see Cylinder (basket) removal).
- Step 2:** Remove water seals from the seal mounting plate on the cylinder shaft. These are removed with your fingers.
- Step 3:** The primary and secondary seals that mount on the sealing ring may be slid over the shaft and seated on the metal sealing ring with your fingers. In the unlikely event that the metal ring that mounts these sealing rings were to be damaged or moved, a new one would need to be pressed on. The seal mounting ring must be pushed against the stop on the shaft. After installing the seals, lubricate the faces of the seals with silicone grease.
- Step 4:** Install cylinder (see Cylinder (basket) reassembly).



Guard Ring & Mating Ring

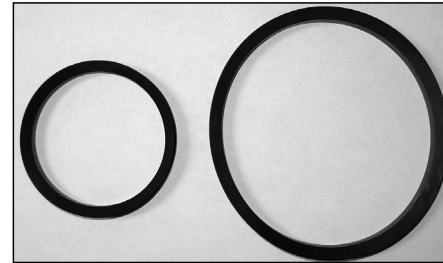

Seals

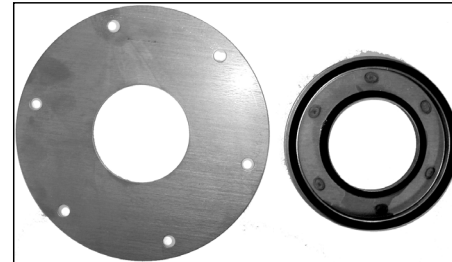

Mating Ring & Mounting Ring

## Outer Tub

### Removal

- Step 1:** The outer tub can easily be removed when the tub front, cylinder and bearing housing has been removed as outlined previously.
- Step 2:** At that point the only attachments to the chassis are the two front strap mounting bolts.

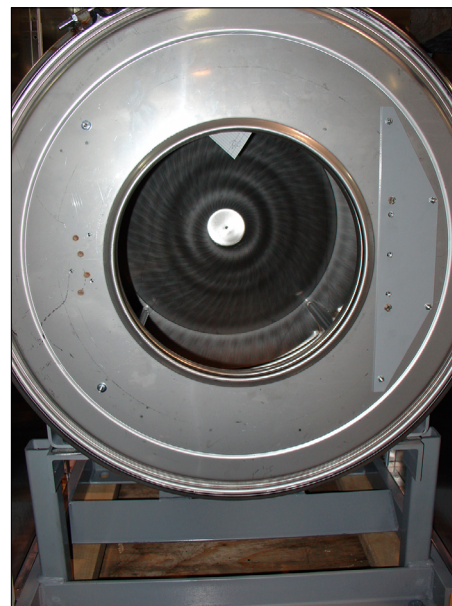

## Reassembly of the Cylinder

- Step 1:** Use the hub of the drive pulley, a stack of 5/8" flat washers and a 3" long 5/8" bolt to pull the cylinder shaft through the bearings. After the 3" bolt a 2" long bolt will be required to finish pulling the cylinder shaft through.
- Step 2:** Remove the 1/2" bolt and nut from the top of the outer tub clamping band.
- Step 3:** Install Dexter Tool part # 8545-056-001 on the back of the outer tub to adjust tub front to cylinder clearance. Thread 5/8" bolt through tool and into cylinder shaft. Push the outer tub forward 1/4" to 1/2" with tool 8545-056-001 by tightening the 5/8" bolt. This will ease the installation of the outer tub front.
- Step 4:** Clean the silicone rubber off the tub front and the outer tub.
- Step 5:** Install new bead of silicone rubber on tub front.
- Step 6:** Install tub front.
- Step 6A:** Align hole in top of tub front with notch in top of outer tub.
- Step 6B:** Use 4-6 #11R vise grip clamps to hold tub front to outer tub. A rubber mallet may be needed to properly seat the tub front into the outer tub.
- Step 6C:** Install tub front gasket around outer edge of tub front and outer tub flange. The opening should be centered at the top.
- Step 6D:** Remove vise grips. The tub front gasket will hold the tub front in place.
- Step 7:** Install tub front clamp ring and tighten. Tap around the clamp ring with a rubber mallet to seat the ring and gasket while tightening the clamp ring bolt.
- Step 8:** Adjust clearance between the outer tub front and the front lip of the cylinder to 5/16".
- Step 9:** Tighten the outer tub clamping band.
- Step 10:** If necessary, the outer tub may be adjusted up or down and side to side with the 2 bolts that fasten the bottom of the outer tub clamping band to the frame.
- Step 11:** Remove Dexter Tool part 8545-056-001 from the back of the outer tub.
- Step 12:** Install drive pulley.
- Step 12A:** Install hub on cylinder shaft.
- Step 12B:** Hold hub against rear bearing with 5/8" bolt and flat washer in end of cylinder shaft.
- Step 12C:** Line up 3 unthreaded holes in pulley with the 3 threaded holes in hub.
- Step 12D:** Insert 3 pulley bolts and tighten evenly alternating bolts to 30ft/lbs.
- NOTE: Overtightening or uneven tightening can break drive pulley.
- Step 13:** Install drive belts & back panel.
- Step 14:** Install door lock. All mounting holes should be sealed with silicone rubber.
- Step 15:** Install door, masking ring, front panel, lower service panel and top.

### T-750 Bolt Torque Chart

Bolt Size	Where Used	Torque
1/2" x 1 1/4" bolt	Tub End of Bearing Hsing. 9545-017-009	70-110 ft/lbs
5/8" x 1 1/2" bolt	Tub End of Bearing Hsing. 9545-060-001	120-150 ft/lbs
1/2" x 1 1/4" bolt	Mtg. of Tub to Cradle Asy. 9545-017-009	70-110 ft/lbs
5/8" x 2 1/2" bolt	Mtg. of Tub to Cradle Asy. 9545-060-001	120-150 ft/lbs
3/8" x 1 1/2" bolt	Tub Back Ring to Tub Back 9545-029-003	45-80 ft/lbs

### T-900, T-950 & T-1200 Bolt Torque Chart

Bolt Size	Where Used	Torque
7/16" Stainless Cap Screw	Outer Tub to Bearing Housing	60-80 ft/lbs
3/4" Bolt	Bearing Housing to Frame	200-300 ft/lbs
1/2" Bolt	Outer Tub Clamping Band to Frame	70-110 ft/lbs
1/2" Bolt	Outer Tub Clamping Band - Top	30-40 ft/lbs
3/8" Cap Bolt	Driven Pulley to Hub	28-32 ft/lbs

### T-1450 Bolt Torque Chart

Bolt Size	Where Used	Torque
7/16" Stainless Cap Screw	Outer Tub to Bearing Housing	60-80 ft/lbs
7/8" Bolt	Bearing Housing to Frame	600-650 ft/lbs
1/2" Bolt	Outer Tub Clamping Ears to Frame	70-110 ft/lbs
3/8" Cap Bolt	Driven Pulley to Hub	28-32 ft/lbs

## Notes

---

---

---

---

---

---

---

---

---

---

---

---

---

---

---

---

---

---

---

---

---

---

---

---

---

---

---

---

---

---

# Section 6:

## Service Electrical Components

### Control Mounting Trough

Remove top panel to access control trough. (see Removing Top Panel) It sets on the right side of the machine and holds the control PCB's, transformers, and pressure switch.

### Main Data Communication Cable

Goes between front PCB board and Variable Frequency Drive unit mounted center rear of machine. It has telephone type connectors at each end and is inserted at Controller PCB and the Variable Frequency Drive.

### Circuit Breaker/Fuse

The fuse (optional circuit breaker) mounts to the rear channel. It carries all of the controls in the machine but does not include the motor. To reset the circuit breaker just push in the button. If you have a fuse then remove fuseholder and fuse and replace with a 1 1/2 amp fast blow type fuse.



Fuse Location

### Main Control Printed Circuit Board

Please be sure to be grounded to machine before removal of this board from machine. PC board mounted vertically behind front control panel. Remove hold down nuts in 4 corners and 1 at bottom center.

### PCB Transformer Step-down

Small transformer mounted at front of control trough that is powered with 120 VAC primary and two secondary outputs of 2.3 VAC and 24-27 VAC.

### Controls Transformer

This transformer is mounted at the back of the control trough and steps a range of 208 to 240 volts down to 120 volts for the controls. There are two terminals on the controls transformer for incoming power. One terminal tap is marked for 208 volts use this tap for measured voltage of 200 volts - 215 volts, and the other tap is marked 230 volts for 216 volts - 240 volts. Note: All washers have a controls transformer. Always check the incoming voltage and use the appropriate transformer terminal when installing ALL washers.

### Main Relay Printed Circuit Board

Please be sure to be grounded to machine before removal of this board. PCB mounting horizontal in control trough towards front of machine. Remove 4 mounting nuts.

### LED Printed Circuit Board Temperature & Start Display/Push-Button

The selector switch is mounted in the center of the control panel and is held in place with five nuts. It allows the selection of hot, warm or cold water temperatures. Note: Do not over tighten on reinstallation as the switch can be damaged, stay pushed in and will cause erratic displays.

## Add-Bleach LED

This LED light indicates to the user the correct time to add bleach. This LED is polarity sensitive and must be connected correctly.

## Pressure Switch Caution (Not recommended by Factory!)

**Changing Factory preset adjustment voids all factory water usage specifications.**

The pressure switch sets the water level in the washer. As the water level rises, it compresses the air in the pressure switch hose. When the washer reaches the desired water level, the compressed air in the pressure switch hose opens the contacts in the switch, shutting off the water. When at the empty level, the pressure switch contacts are closed allowing the machine to either spin or fill with water. The 1/4"

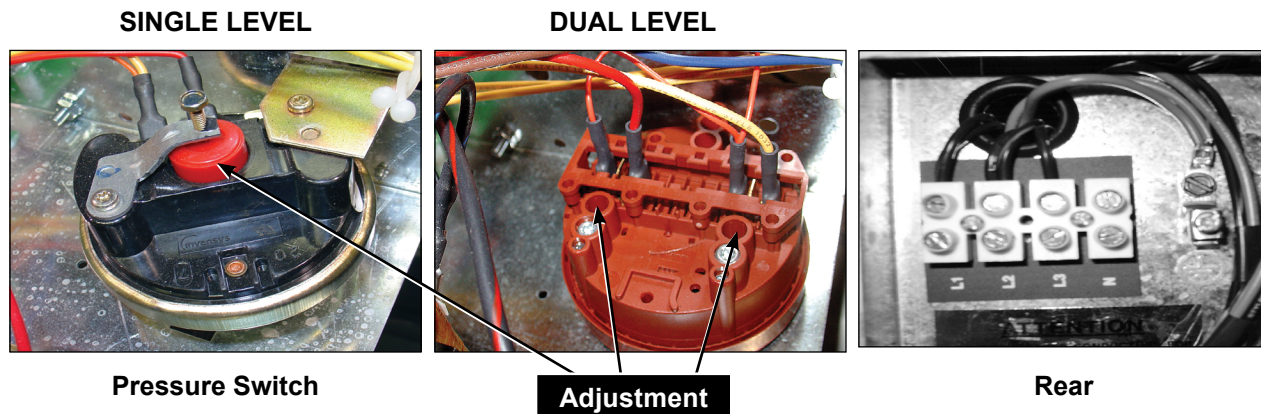

screw in the middle of the switch adjusts the water level. Counter clockwise will lower the water level, and clockwise will increase the water level on the single level switch. The dual level switch can be adjusted by turning the torx screws as shown. Before making any adjustments of the pressure switch, drain the tub and blow the hose clear of possible water bubbles which can cause erratic pressure switch operation.

## Emergency Stop Button Switch Assembly

The stop button is mounted on right side of machine. Remove the top and access the rear of button. Remove the plastic retainer by unthreading CCW. The switch assembly will have to be removed by pressing down on the plastic clip while pulling the switch body away from the stop button.



**Temperature and Start Display**



**Stop Button Switch Assembly**

## Power Connection Terminal Block

This terminal block sets at the very back of the control trough. Incoming power to the washer should connect here. (see Electrical under Installation and Operation Section for exact connections)

## Delta Variable Frequency Drive:

Main power is connected to terminals L1, L2, and L3 on the Delta drive. If the washer is connected to a three phase source, there should be voltage present on all three terminals. If the washer is connected to single phase power, there should be voltage present on terminals.

The voltage should measure 208 Volts to 240 Volts A.C. between phases and connected to if connected to three phase). There is a tolerance of + 10% on the mains voltage (187 Volts to 264 Volts).

## Delta VFD Motor Leads:

The wires from the motor are connected to terminals T1, T2, and T3. Since this drive uses pulse width modulation, an accurate current or voltage reading is not possible. Although an accurate current reading is not possible, a balanced current reading should be present while the motor is running.

## Delta VFD Dynamic Braking Resistors:

Two, 160 Ohm or 200 Ohm braking resistors (Please check your washer model parts requirements and quantities), are connected in parallel and attached to the drive at terminals B1 and B2. These resistors allow voltage, which is generated by the motor when decelerating, to be dissipated. They will become hot while the motor is slowing down, so care should be taken so as not to come in contact with them. This will prevent an electrical shock and/or a physical burn.

## Delta VFD Cooling Fan:

There is a cooling fan attached to the bottom of the Delta drive. This fan will operate when the internal temperature of the drive reaches a predetermined level, the same way the radiator fan in a newer car operates. THE FAN CAN OPERATE ANYTIME POWER IS APPLIED TO THE DRIVE! Remove power to the drive if work is required around the fan.

---

# Section 7:

## Electrical Wiring Diagrams & Schematics

---

## Electrical Path Circuit Schematics

### Start Circuit

Power travels into the machine on L1 & L2 & (L3, if 3 phase used). L1 and L2 provide 208- 240VAC to the controls transformer which steps the voltage down to 120VAC for the controls. (The L1 connection at the controls transformer must be checked at start-up to coincide with machine operating voltage) The 120VAC travels out from the transformer on either [X-1 red wire directly to the 1.5 amp fuse] or [X-1 black/red wire to TB-4 and then through the red wire to the 1.5 amp fuse]. The controls transformer also creates a neutral on the X-2 black/blue wire that connects to TB-1. From the fuse holder, 120VAC travels on the red wire to the #6 terminal on the terminal strip and then through the black wire to another step-down transformer. From the terminal strip the blue wire will provide the neutral for solenoid, thermoactuators and all valves. The white wire provides the neutral from the terminal to the step down transformer.

120VAC is stepped down to 2.3VAC (blue wires), 24VAC (red wires), and a yellow center tap wire to the P-7 power connection on the main controller PCB. With the main control PCB now powered, 5VDC will be present between the (2) yellow wires and also the (2) brown wires for the coin switches. Both pairs will now be ready to count coins through the P-2 connection at the control PCB. 26.8 VAC goes out on the black wire of the P-4 connection from the main control PCB to the S5 door closed switch which mounted on the hinge side of masking ring. Closing the door will engage the door closed switches, sending the voltage to the red wire on the S1 door latched switch. Turning the door handle to the vertical latched position closes the S1 door latched switch, returning the voltage to the main control PCB on the white/red wire at the P-4 connection. 26.8VAC is now present at the S2 and S3 door locked switches.

26.8VDC is also at the black and white wires between P-21 at the main control PCB and the P-20 of the relay PCB. This voltage signals the relay PCB that the door is closed and latched making 120VAC available to the relays controlling the door lock solenoid, drain valve and water valves. A continuous 5VDC is sent on the red wire from the P-1 connector on the main control PCB, through the (normally closed) emergency stop button switch and returns on the second red wire back to the P-1 connector. Payment is added and the display counts down on the main control PCB display until the vend price is satisfied. The display will change to read PUSH and the green light over the start button will flash. Pressing the start button on the front of the main control PCB signals the relay PCB to lock the door and 120VAC will go to the door lock solenoid on the white/red wire from the P17 connector of the relay PCB. The door lock solenoid engages and pulls up on the door locking rod, locking the door and closing the S2 and S3 door locking switches.

The S2 locking switch is a backup to the S1 latching switch so that once the cycle starts the S1 isn't critical. The S3 locking switch provides 26.8VDC on the orange wire back to P4 connector at the main control PCB and the P15 connector at the relay PCB. This signals that the loading door is closed, locked and safe to continue wash operations. This activates the P-13 and P-14 yellow enable wires to the inverter drive to allow motion. If there is no signal on P-15 (orange wire) their will be no motion of the tub. S1, S2, S3 and S5 door switches are now closed. The green On LED and the door lock solenoid (discussed in start circuit) will remain on throughout the cycle.

### Fill Circuit-Warm

The relay PCB supplies 120VAC to the brown/yellow wire from P-17 to the drain valve which closes the valve. The lock thermoactuator also receives 120VAC on orange/blue from P17 of the relay PCB. This device prevents the door lock solenoid from dropping out and unlocking during the cycle in the event of a power loss. The 120VAC will cycle on and off keeping the lock thermoactuator engaged until 70 seconds before the end of the cycle. The main control PCB sends data commands to the VFD through the data cable connected at P-6. These commands control the wash basket which will tumble one direction for 12 seconds, pause, and then reverse direction for 12 seconds.

The prewash or wash LED will illuminate at this time, powered through the white wires from the P-3 con-

---

nection of the main control PCB to the LED printed circuit board. Using the factory preset cycle as an example: The washer fills the tub through the back of the machine with either one or both the C1 cold and H1 hot water valves. From the P19 connection of main relay PCB, 120VAC is sent out on the white/brown wire to the C1 cold water fill valve and the red/yellow wire to the H1 hot water fill valve depending on the temperature selected. After a 90 second delay from the beginning of the wash cycle bath only, the detergent dispenser flushes the detergent into the tub for 20 seconds. This is accomplished when 120VAC travels through the red/orange wire to the H2 hot water valve solenoid. During the machine fill, a 5VDC signal is sent on the red wire from the P5 connection of the main control PCB to the pressure switch contact and returns on the yellow and orange wires to the P5 connection of the main control PCB. When the water level in the basket reaches the preset level pressure, the switch moves the switch contacts to the full or open position. This causes the main control PCB to signal the relay PCB to shut off the water valve coils.

### **Wash Circuit**

Once the machine has achieved it's water level, the wash basket will continue to tumble one direction for 12 seconds, pause, and then reverse direction for 12 seconds. The time on the front display will count down as the bath progresses. The time of the bath is programmable up 15 minutes per bath. Note: When programming cycles, the wash bath must be programmed for 3 minutes or more.

### **Drain**

When the program bath time ends the main control PCB signals the relay PCB to remove 120 VAC power from brown/yellow wire at P17 going to the drain valve. The normally-open, spring-loaded drain valve opens allowing water to exit the machine. This resets the pressure switch back to an empty level and restores the 5VDC connection through the pressure switch from the red wires to the orange and yellow wires.

### **Rinse 1 & 2**

For Rinse 1 & 2, the rinse LED will illuminate, the drain valve will receive 120VAC and close. The basket will fill and tumble the same as the wash bath for the programmed time. The rinse water temperatures are programmable and factory default is cold.

### **Final Rinse Circuit**

The final rinse LED will illuminate, the drain valve will receive 120VAC and close. The basket will fill and tumble the same as the previous baths for the programmed time. The final rinse water temperatures are programmable. Note: When programming cycles, the final rinse bath must be programmed and cannot be set for less than 3 minutes. Also at the beginning of the final rinse bath, the main control PCB will signal the relay PCB to send 120V to the P-19 connector on the white/blue wire to the C2 cold water valve for 20 seconds to flush the fabric softener dispenser.

### **Spin Circuit**

The spin LED will illuminate and the main control PCB sends a signal to the variable frequency drive via the data cable at P6 to VFD RJ-11. The rotation as viewed from front during spin will be counter-clockwise. (The 18lb washers will extract in a clockwise direction) The time of the spin cycle can be programmed. Note: The final spin must be programmed into the final rinse bath and must be programmed for 1 minute or more.

---

### **Unlock Thermoactuator and Shake Out Circuit**

70 seconds before the end of the cycle the main control PCB signals the relay PCB to remove 120VAC from the orange/blue wire at the P-17 connector on the lock thermoactuator. This allows the lock thermoactuator time to cool and retract by the end of the cycle. To insure that the lock thermoactuator has retracted by the end of the cycle, 1 minute prior the end of the cycle, the unlock thermoactuator is powered with 120VAC through the orange/red wire from the P-17 connector of relay PCB. The unlock thermoactuator moves the complete bracket assembly away from the door lock solenoid allowing it to drop at the end of the cycle. The basket will come to a stop from spin speed with the assistance of dynamic braking resistors wired to the variable frequency drive. (See wiring diagrams for quantities and resistor ohm values). The washer will then tumble for 45 seconds to let the clothes shake loose from the basket and then stop.

### **End of Cycle and Door Open Circuit**

Once the machine stopped, 3 things occur: 1. The beeper will signal for 5 seconds letting the user know that it is the end of the cycle. 2. The main control PCB signals the relay PCB to remove power from the white/red wire at P-17 which allows the door lock solenoid to unlock. 3. The main control PCB resets when the S1,S2,S3,S5 switches open and door is opened. The machine is now ready to accept coins again.



# CN (No coin Mech) 50lb Express WCAD50KCB-CNSZ Diagram

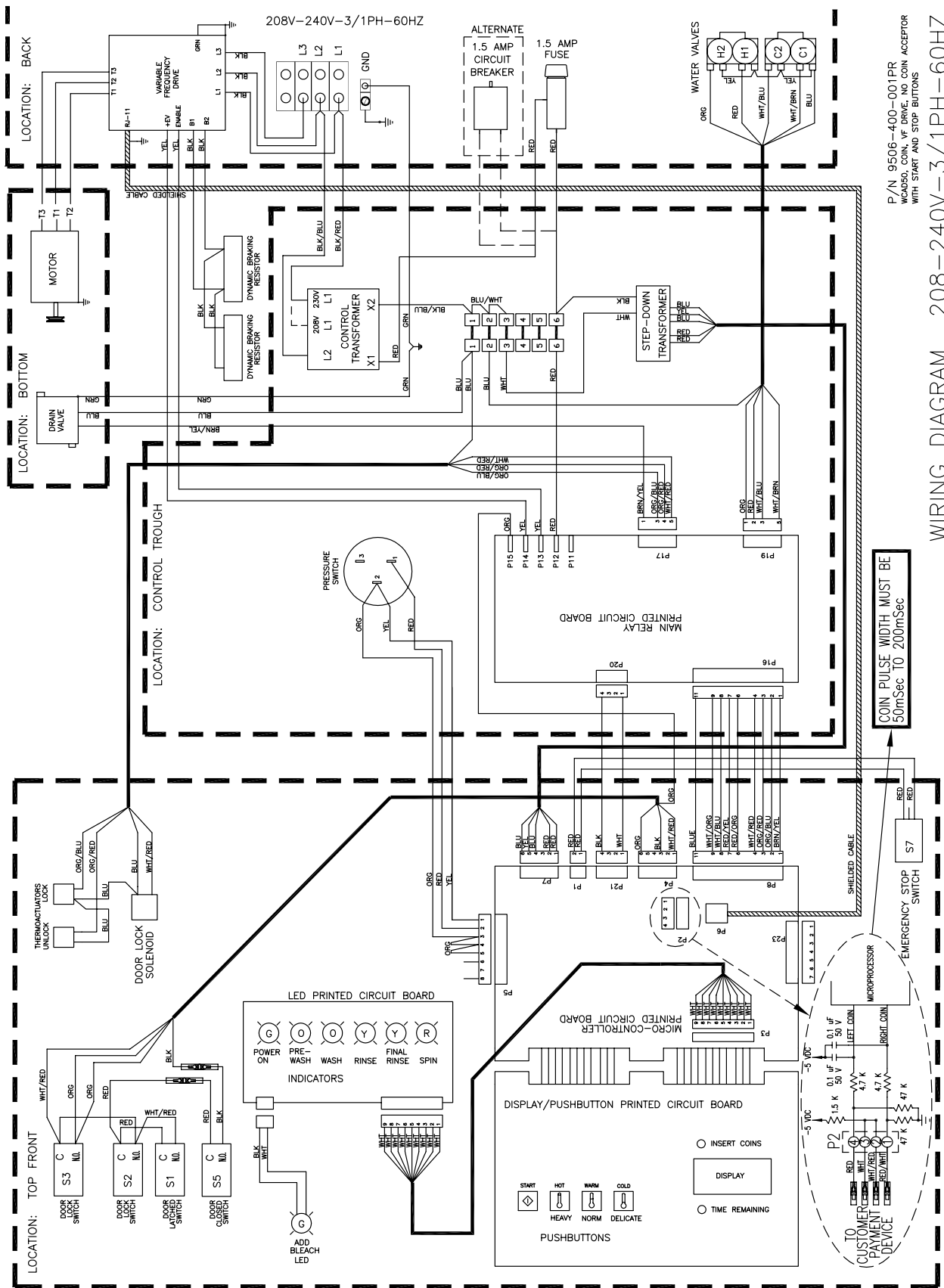

P/N 9506-400-001PR  
W/DRN, COIN, V.F. DRIVE, NO COIN ACCEPTOR  
WITH START AND STOP BUTTONS

WIRING DIAGRAM 208-240V-3/1PH-60HZ

# CN (No coin Mech) 60lb WCAD60KCB-CN Schematic

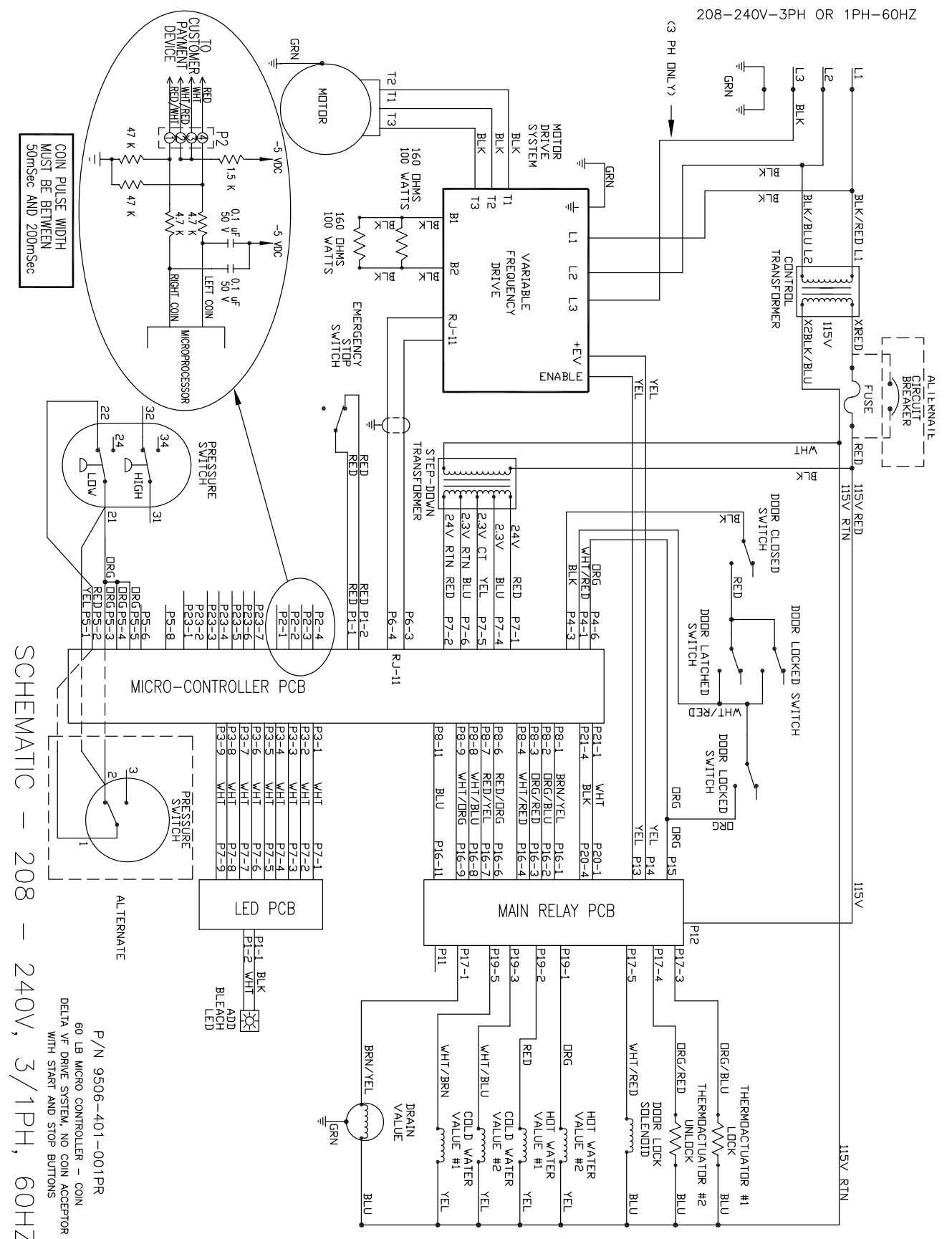

P/N 9506-401-001PR  
60 LB MICRO CONTROLLER - CON  
DELTA V.F. DRIVE SYSTEM, NO COIN ACCEPTOR  
WITH START AND STOP BUTTONS

SCHEMATIC - 208 - 240V, 3/1PH, 60HZ

# CN (No coin Mech) 60lb WCAD60KCB-CN Diagram

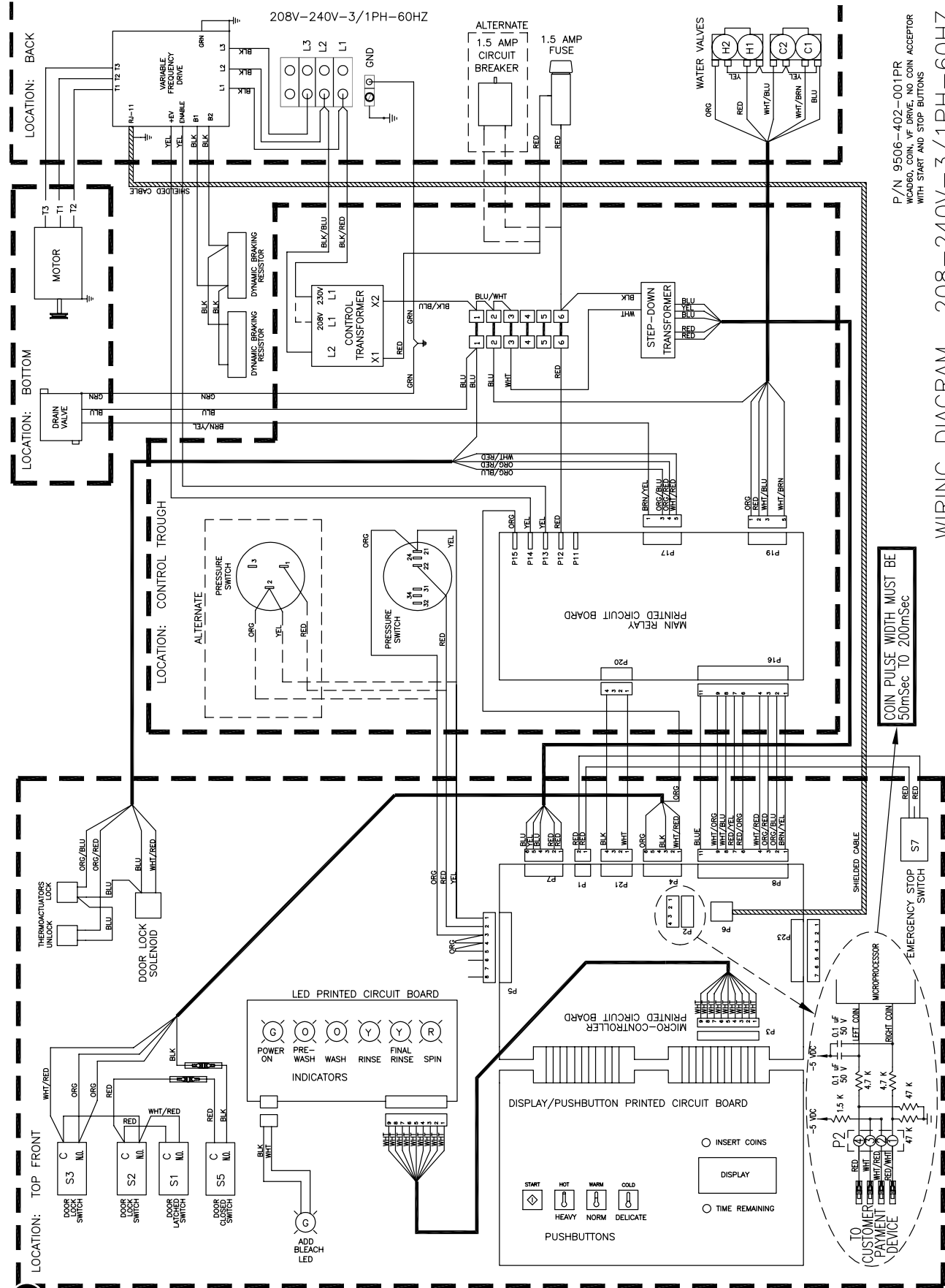

# CN (No coin Mech) 60lb Express WCAD60KCB-CNSZ Schematic

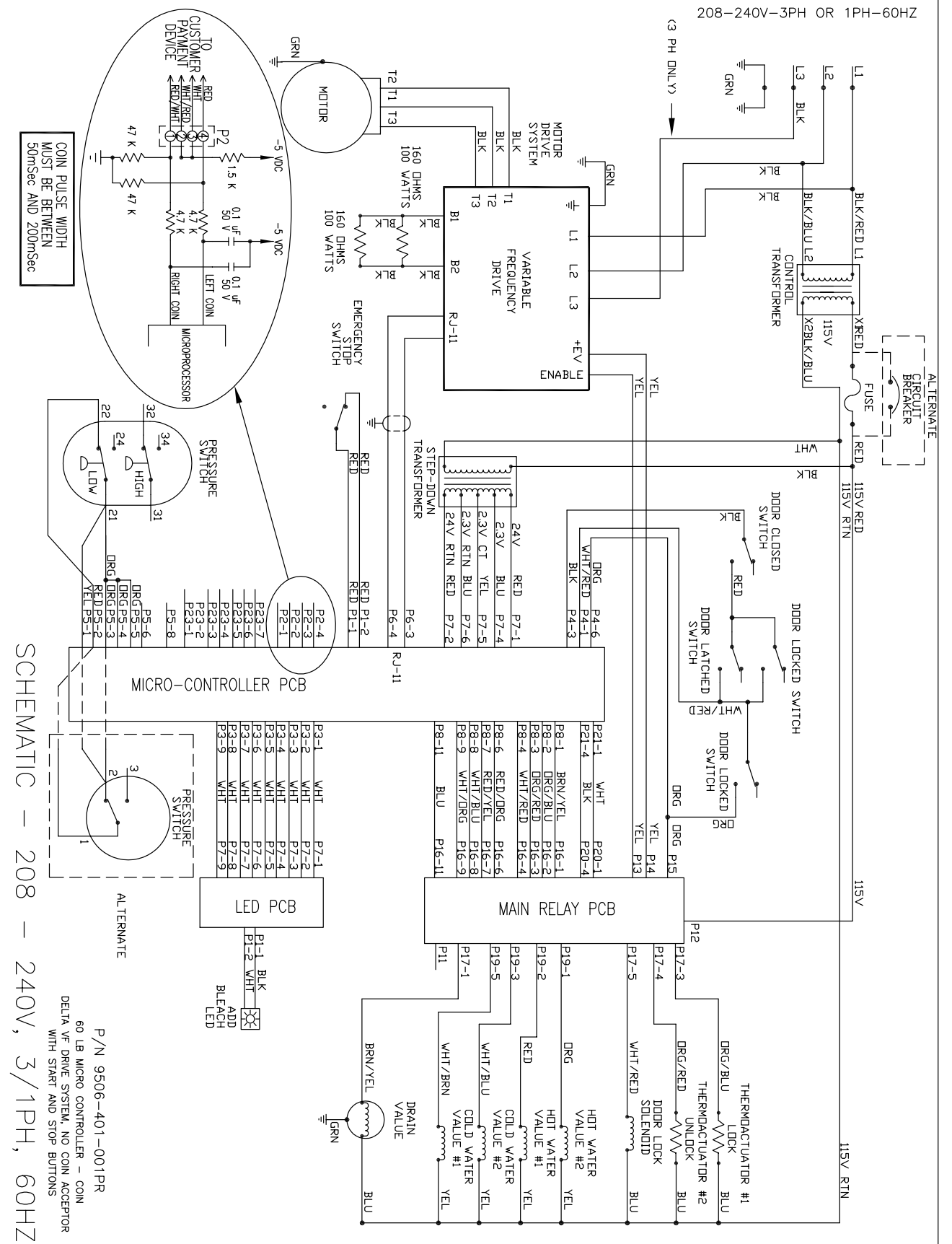

# CN (No coin Mech) 60lb Express WCAD60KCB-CNSZ Diagram

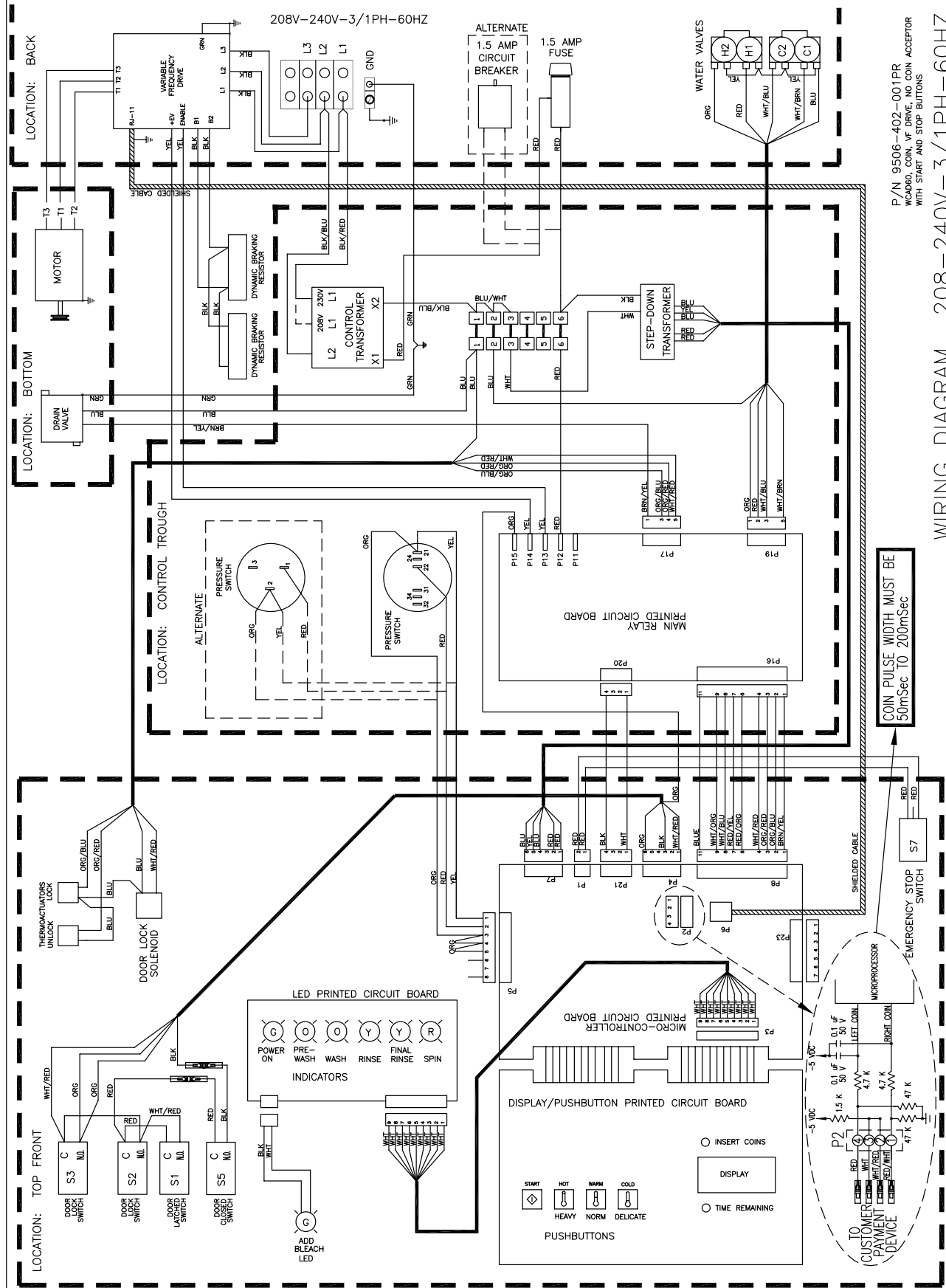

# CN (No coin Mech) 80lb WCAD80KCB-CN Schematic

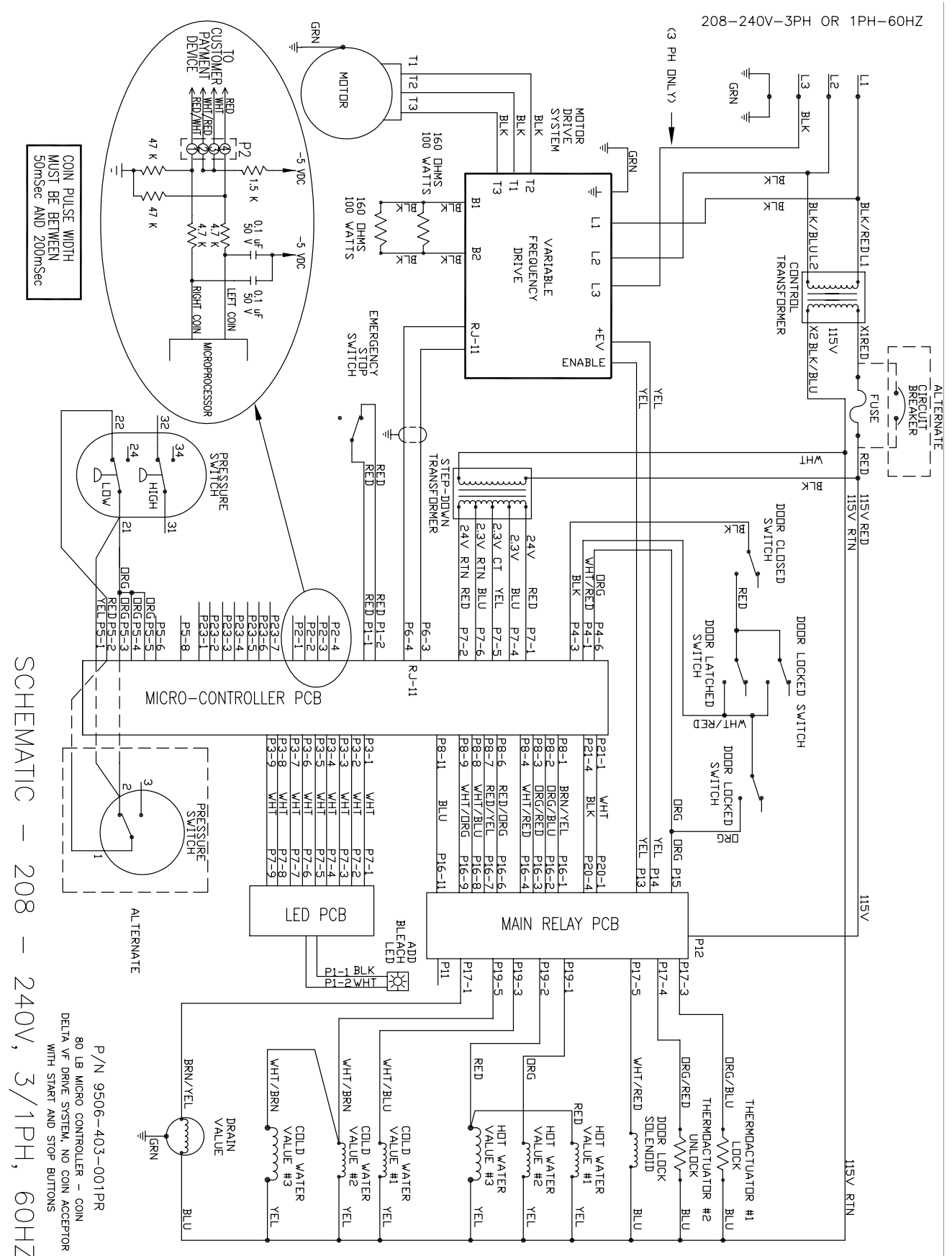

# CN (No coin Mech) 80lb WCAD80KCB-CN Diagram

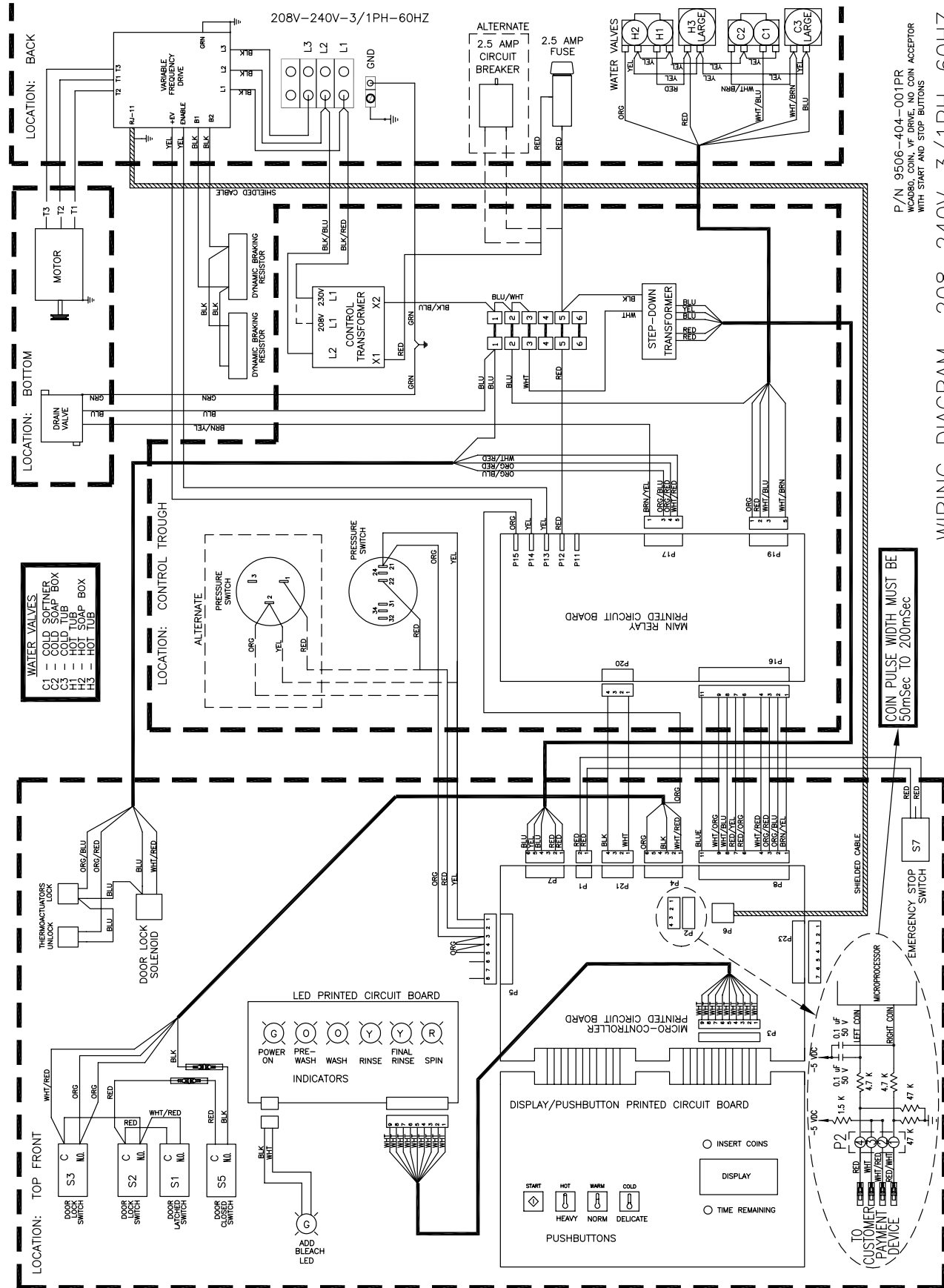

# CN (No coin Mech) 90lb Express WCAD90KCB-CNSZ Schematic

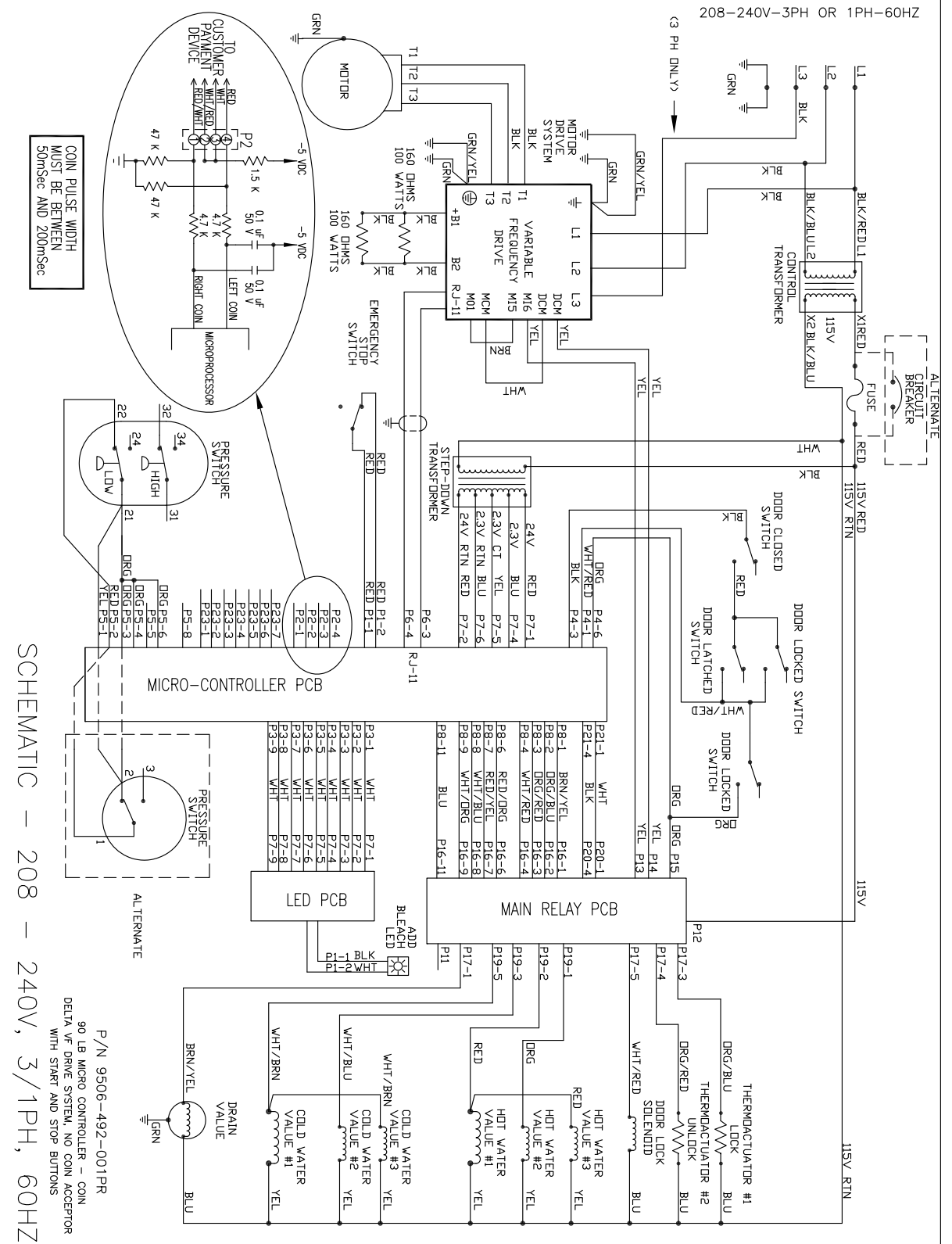

**CN (No coin Mech) 90lb Express  
WCAD90KCB-CNSZ Diagram**

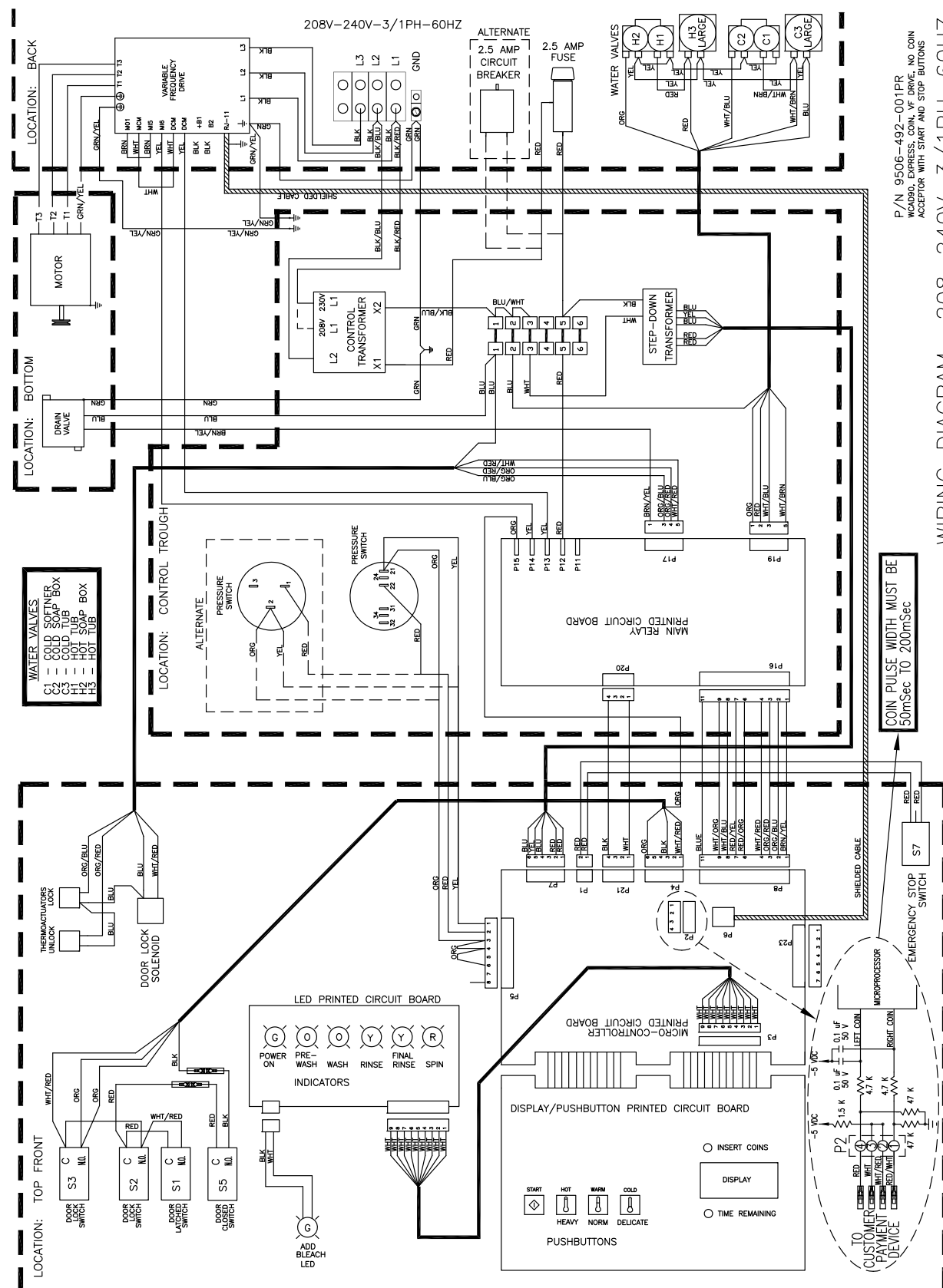

COIN PULSE WIDTH MUST BE  
50mSec TO 200mSec

**Notes**

---

---

---

---

---

---

---

---

---

---

---

---

---

---

---

---

---

---

---

---

---

---

---

---

## A-Series Accessories

\*WCAD45KC-12SZ 208-240 volts 60hz. Single Phase or Three Phase  
(Parts differences for the regular door T-650 will be found on pages 104-105)

WCAD50KC\_-12USSZ 208-240 volts 60hz. Single Phase or Three Phase  
WCAD60KC\_-12USSX 208-240 volts 60hz. Single Phase or Three Phase  
WCAD60KC\_-12USSZ 208-240 volts 60hz. Single Phase or Three Phase  
WCAD80KC\_-12USSX 208-240-volts 60hz. Single Phase or Three Phase  
WCAD90KC\_-12USSZ 208-240 volts 60 hz. Single Phase or Three Phase

Key	Description	T-750	T-900	T-950	T-1200	T-1450	
*	Hose, Water Supply 3/8" I.D. x 48"						2
*	Hose, Water Supply 5/8" I.D. x 48"	9990-027-013	9990-027-013	9990-027-013			2
	Hose, Water Supply 5/8" I.D. x 48"				9990-027-013	9990-027-013	4
*	Washer, Inlet Hose (furnished)	8641-242-000	8641-242-000	8641-242-000	8641-242-000	8641-242-000	2
*	Strainer, Inlet Hose (furnished)	9565-003-001	9565-003-001	9565-003-001	9565-003-001	9565-003-001	2
*	Bevel Washer for 5/8" bolt used in installations using angle iron bases		8641-586-002		8641-586-002		
*	Bevel Washer for 3/4" bolt used in installations using angle iron bases	8641-586-003	8641-586-003	8641-586-003	8641-586-003	8641-586-003	4
*	Sealing compound	8538-151-001	8538-151-001	8538-151-001	8538-151-001	8538-151-001	1
*	TORX#20	8545-051-002	8545-051-002	8545-051-002	8545-051-002	8545-051-003	1
*	Special Tool For Removing Coin Acceptor Mounting Screws. (T-10 Torx)	8545-051-003	8545-051-003	8545-051-003	8545-051-003	8545-051-003	1
*	Flow Restrictors (in dispenser )	9475-002-002	9475-002-002	9475-002-002	9475-002-003	9475-002-002	2
*	Battery (used on Control PCB)	8612-001-001	8612-001-001	8612-001-001	8612-001-001	8612-001-001	1
*	Special Tool for adjusting spacing between outer tub front and cylinder front	8545-056-001	8545-056-001	8545-056-001	8545-056-001	8545-056-001	1
*	VFD Filter options (1 phase) 120v						1
*	VFD Filter options (3 phase)	9732-255-001	9732-255-001	9732-255-001	9732-256-001	9732-255-001	1
*	VFD Filter options (1 phase)	9732-230-001	9732-230-001	9732-230-001	9732-251-001	9732-230-001	1
*	Puller for pushing cylinder out of bearings must be purchased from local sources.						1
*	Clamps to hold tub front to outer tub when installing tub front	Vise Grip #11R	Vise Grip #11R	Vise Grip #11R	Vise Grip #11R	Vise Grip #11R	1
*	Coin Bearing & Seal Kit	9732-219-007	9732-219-007	9732-219-007	9732-219-007		1
*	Coin Op CD with OS2 Platform for A Series Washers Only		9504-015-001		9504-015-001		
	Key Service Lock (6324)	6292-006-007	6292-006-007	6292-006-007	6292-006-007	6292-006-007	1
*	Mode Light Support	9635-022-001	9635-022-001	9635-022-001	9635-022-001	9635-022-001	1
*	MS300 Display	9150-058-001	9150-058-001	9150-058-001	9150-058-001	9150-058-001	*
*	A to C Series Kits	9732-306-007	9732-306-008	9732-306-009	9732-306-010	9732-306-011	*

## Kits, Assemblies, & Common Parts

Coin Acceptor Components	Part Number
Optical Coin Acceptor	9021-092-002
Optical Coin Switch Replacement	9801-099-001
Electronic Coin Acceptor (T-1450 only)	9021-077-001
Mechanical Coin Acceptor	9021-001-010
Coin Drop Screws	9545-053-002
Retainer, Coin Acceptor	9486-149-001
Loading Door & Door Lock Components	Part Number
Door Glass Gasket (Large Door)	9206-431-001
Door Glass Gasket (Standard Door)	9206-419-001
Door Handle Only (Large)	9244-091-001
Door Handle Only (Small)	9244-080-003
Door Close Switch	9539-492-001
Door Lock Gear Motor Assembly	9922-015-001
Kit - Door Latching Assy. & Cam (replaces original Door Latching Assembly)	9732-347-001
Kit - Door Cam Replacement	9732-346-002
Kit - Locking Pawl Replacement	9732-346-001
Kit - Door Gasket Expander Kit (Small)	9732-139-001
Kit - Door Gasket Expander Kit (Large)	9732-139-002
Electrical Components	Part Number
Transformer, Main	8711-004-001
Transformer, Control	8711-009-001
Main Control Board	9473-009-005
Kit-Replacement, Pressure Sensor (Only)	9732-315-001
VFD & Breaking Resistors Components	Part Number
Breaking Resistor 200 Ohms	9483-004-002
Breaking Resistor 160 Ohms	9483-004-003
Delta E Drive Display	9150-044-001
MS 300 VFD Display	9150-058-001
Data Cable (56")	9806-015-003
Drain & Water Valve Components	Part Number
Kit - 3" Drain Valve Seal Replacement	9732-327-001
Drain Valve 3"	9379-202-001
Water Valve (Dual)	9379-183-012
Water Valve (Single Mueller)	9379-194-001
Diaphragm (Dual)	9118-049-003
Diaphragm (Single Mueller)	9118-055-001
Cabinet Components	Part Number
Front Panel Screw	9545-008-014
Front Panel Finisher Washer	8641-585-001
Front Panel Spring Nut	8640-399-008
Top Soap Box Screw (Regular Chassis Only)	9545-008-012
Top Soap Box Spring Nut (Regular Chassis Only)	8640-399-007
5/16 Hex Screw, Common	9545-008-026
Top Lock Key #6324	9306-025-001
Cylinder Plug (1.5" Plastic)	9456-041-007



## Section 8:

Parts Data  
WCAD Vended  
Large Chassis

## Wiring Harness Part # by Model

Key	Description	T750	T-900	T950	T-1200	T1450	QTY
*	Wiring Harness (Add Bleach Lite assy included)	9794-001-001	9794-001-001	9794-001-001	9794-001-001	9794-001-001	1
*	Wiring Harness, Door Lock	9627-791-005	9627-791-004	9627-791-004	9627-791-005	9627-791-005	1
*	Wiring Harness,CoinDrop Mech	9627-792-001	9627-792-001	9627-895-001	9627-792-001	9627-792-001	1
*	Wiring Harness, Drain,Thermo,DoorSol	9627-796-002	9627-796-002	9627-796-002	9627-796-002	9627-796-002	1
*	Data Cable	9806-015-001	9806-015-001	9806-015-001	9806-015-003	9806-015-003	1
*	Wiring Harness P20/P21	9627-793-001	9627-793-001	9627-793-001	9627-793-001	9627-793-001	1
*	Wiring Harness P8/P16	9627-794-001	9627-794-001	9627-794-001	9627-794-001	9627-794-001	1
*	Wiring Harness WaterValve/P19	9627-795-004	9627-795-004	9627-795-004	9627-795-004	9627-795-004	1
*	Wiring Harness LED PCB	9627-797-001	9627-797-001	9627-797-001	9627-797-001	9627-797-001	1
*	Wiring Harness P5/pressure	9627-803-001	9627-803-001	9627-803-001	9627-803-001	9627-899-001	1
*	Wiring Assembly Yel. 32"		8220-064-023	8220-064-023			2
*	Wiring Assembly Yel. 64"				8220-064-040	8220-064-040	2
*	Wiring Assembly Red 23" #8	8220-063-028					1
*	Wiring Assembly Red 41"				8220-062-032	8220-062-032	2
*	Wiring Assembly Vio. 24"				8220-118-001	8220-118-001	2
*	Wiring Assembly Wht/Brn 8"				8220-108-007	8220-108-007	1
*	Wiring Assembly Jumper Yel	8220-123-001	8220-123-001	8220-123-001	8220-128-001	8220-128-001	1
*	Wire Red Yellow 8"				8220-108-008	8220-108-008	1
*	Wire Yellow Jumper (water valve)				8220-119-002	8220-119-002	1
*	80lb Washer Dispenser Label				8502-687-001	8502-687-001	1
*	Wiring Assembly Red 28" #24	8220-062-025	8220-062-025	8220-062-025			2
*	Wiring Assembly Blk. 17"		8220-062-028	8220-062-028	8220-062-028	8220-062-028	1
*	Wiring Assembly Red 17"		8220-062-027	8220-062-027	8220-062-027	8220-062-027	1
*	Wiring Assembly Jumper BLK.	8220-117-002	8220-117-002	8220-117-002	8220-117-003	8220-117-003	2
*	Wiring Assembly Red 7" #36	9631-381-018	9631-381-018	9631-381-018	9631-381-018	9631-381-018	1
*	Wiring Assembly Blu/Wht	8220-090-009	8220-090-009	8220-090-009	8220-090-009	8220-090-009	1
*	Wiring Assembly Blk/Blu	8220-001-231	8220-001-231	8220-001-231	8220-001-231	8220-001-231	1
*	Wire Assembly Green 7"						1
*	Wire Assembly BLK. 23" #8	8220-063-029					
*	Harness Power Terminal Block	9627-747-003	9627-747-002	9627-747-002	9627-747-002	9627-747-002	1
*	Wire Red Yellow 8"				8220-108-008	8220-108-008	1
*	Wire Yellow Jumper (water valve)				8220-119-002	8220-119-002	1

## Cabinet and Front Panel Group Part # by Model Large Door Before Serial # 535659

Key	Description	T-750	T-900	T-950	T-1200	T-1450	
1	Panel, Side (Left or Right) - stainless	9454-812-001					2
1	Panel, Side (Left or Right) - stainless		9454-813-001		9732-359-003		4
*	Strap Assembly (side panel)	9966-013-001	9966-012-001		9966-012-002		4
*	Shim (side panel)	9552-041-001	9552-039-001		9552-042-001		2
*	Screw, (Side Panel to Base)	9545-018-013					6
*	Screw, (Side Panel to Base)		9545-018-013		9545-018-013		8
*	Nut, Hex 1/4-20 UNC (for strap assembly to base)	8640-414-006					6
*	Nut, Hex 1/4-20 UNC (for strap to base)		8640-414-006		8640-414-006		8
2	Bracket, Side Panel under front panel	9046-085-001	9046-085-001		9046-085-001		1
*	Screw #10Bx1/2 side panel brkt	9545-008-026					1
*	Nut 1/4-20 UNC side panel brkt	8640-414-006					1
*	Nut, Hex		8640-413-002		8640-413-002		2
*	Screw		9545-008-024		9545-008-024		2
3	Panel Assy, Front	9454-810-001	9454-810-001		9989-618-002		1
*	Stop Button Mounting Plate	9452-725-001	9452-725-001		9452-725-001		1
*	Band, Edge Protector	9578-072-002					1
4	Bumper Loading Door	9051-055-001	9051-055-001		9051-055-001		1
*	Nut, 1/4 x 20 for bumper	8640-414-006	8643-414-006		8643-414-006		1
*	Screw, Hex- To Control Panel	9545-008-024	9545-008-024		9545-008-024		2
*	Nut, Spring- To Control Panel 10/32	8640-442-001	8640-442-001		8640-442-001		2
5	Screw, Flat Head- Front to Sides	9545-008-014	9545-008-014		9545-008-014		2
5	Screw, Flat Head- Front to Sides						4
6	Washer, Finish	8641-585-001	8641-585-001		8641-585-001		2
6	Washer, Finish						4
*	Nut, Spring-To Front Panel	8640-442-001	8640-442-001		8640-442-001		2
7	Label, Door Opening (Blue)	8502-723-001	8502-723-001		8502-723-001		1
7	Label, Door Opening (Black)	8502-742-001	8502-742-001		8502-742-001		1
8	Panel, Control (Mounts Name-plate)	9989-500-001	9989-500-001		9989-500-001		1
*	Screw, Control Panel to Sides	9545-008-026	9545-008-026		9545-008-026		4
9	Nameplate Decal, Control Blue	9412-162-001	9412-141-001		9412-142-001		1
9	Nameplate Decal, Control Black		9412-165-001				
10	Panel Top	9454-743-001	9454-736-001				1
11A	Panel Top Front				9454-761-001		1
11B	Panel Top Rear				9454-762-001		1
12	Lock, Top (w/Key)	8650-012-003	8650-012-003		8650-012-003		2
13	Door, Lower Service	9960-286-004	9960-286-004		9960-286-004		1
14	Handle (bumper guard)	9244-086-003	9244-086-003		9244-086-003		1
*	Rivet Blind 3/16" Alum		9491-009-003		9491-009-003		4
*	Screw		9545-045-010		9545-045-010		4
15	Screw Mtg., Flat Head 10Bx1 3/4	9545-008-014	9545-008-014		9545-008-014		2
16	Washer, Finish	8641-585-001	8641-585-001		8641-585-001		2
*	Nut, Spring	8640-442-001	8640-442-001		8640-442-001		2

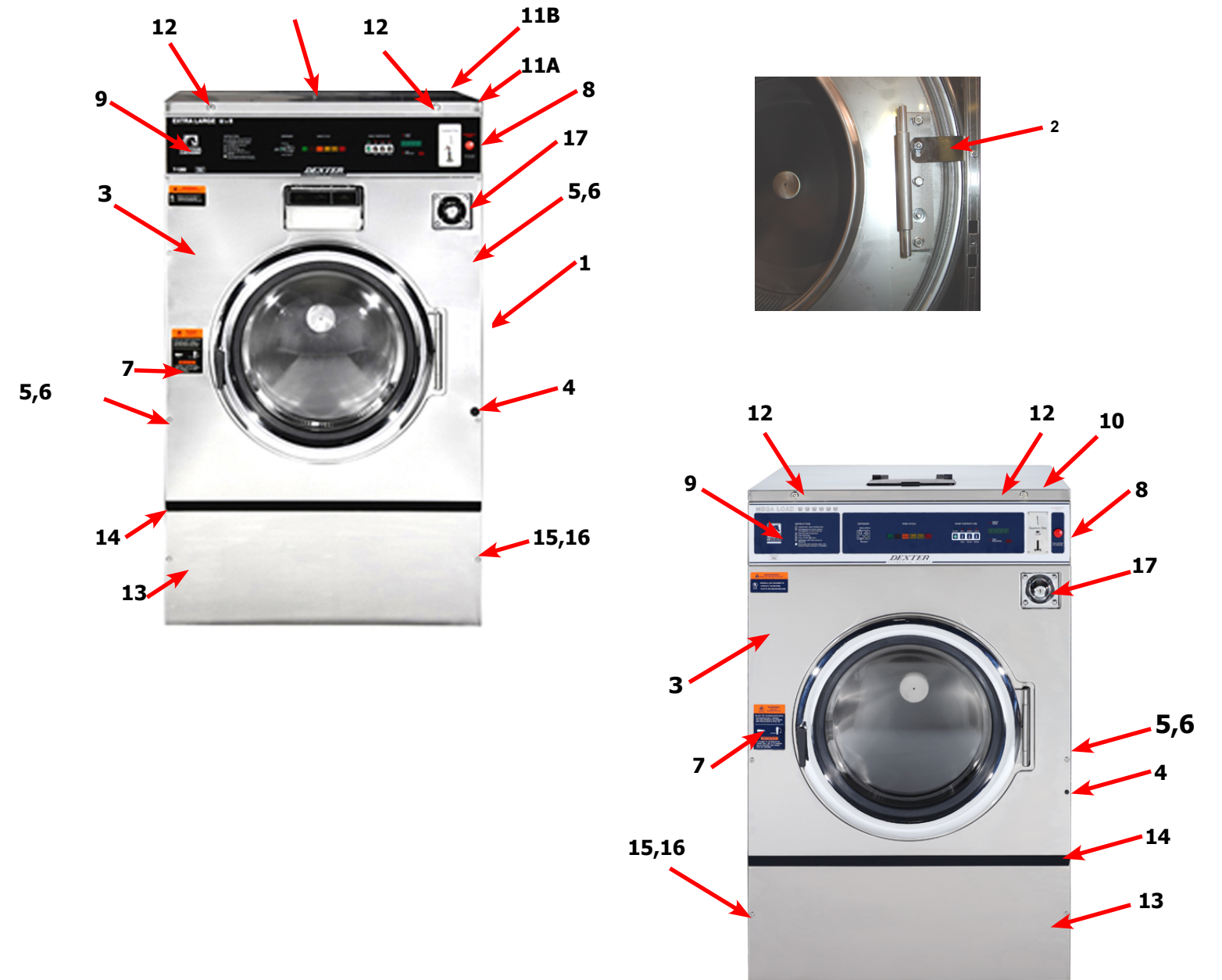

Key	Description	T-750	T-900	T950	T-1200	T1450	QTY
17	Coin Box assy, Large Blue	9807-099-002	9807-099-002		9807-099-002		1
17	Coin Box assy, Large Blue				9807-099-004		
*	Key, Top- # 6324	6292-006-007	6292-006-007		6292-006-007		1
*	Cam, Lock-Top	9095-038-001	9095-038-001		9095-038-001		1
*	Nut, 9/32 - 28 Hex	8640-426-001	8640-426-001		8640-426-001		1
*	Washer Flat 5/16	8641-581-008	8641-581-008		8641-581-008		1
*	Coin Vault, S.S.	9942-037-001	9942-037-001		9942-037-001		1
*	Coin Vault, Black	9942-037-005	9942-037-005		9942-037-005		1
*	Screw, 10B x 1/2	9545-008-026	9545-008-026		9545-008-026		4
*	Chute, Coin	9119-031-001	9119-031-001		9119-028-001		1
*	Screw, Coin Schute	9545-008-001	9545-008-001		9545-008-001		2

## Cabinet and Front Panel Group Part # by Model

### Large Door After Serial # 535659

Key	Description	T-750	T-900	T950	T-1200	T1450	QTY
1	Panel, Side (Left or Right) - stainless	9454-812-001					2
1	Panel, Side (Left or Right) - stainless		9732-359-002	9732-359-002	9732-359-003	9732-359-004	4
*	Strap Assembly (side panel)	9966-013-001	9966-012-001	9966-012-001	9966-012-002	9966-012-002	2
*	Shim (side panel)	9552-041-001	9552-039-001	9552-039-001	9552-042-001	9552-044-001	
2	Screw, (Side Panel to Base)						6
2	Screw, (Side Panel to Base)		9545-018-013	9545-018-013	9545-018-013	9545-018-013	8
2	Nut, Hex 1/4-20 UNC (for strap assembly)	8640-414-006					6
2	Nut, Hex 1/4-20 UNC		8640-414-006	8640-414-006	8640-414-006	8640-414-006	8
3	Bracket, Side Panel under front panel	9046-085-001	9046-085-001	9046-085-001	9046-085-001	9046-086-001	1
*	Screw #10Bx1/2 side panel brkt	9545-008-026					1
*	Nut 1/4-20 UNC side panel brkt	8640-414-006					1
•	Nut, Hex		8640-413-002	8640-413-002	8640-413-002	8640-414-006	2
*	Screw		9545-008-024	9545-008-024	9545-008-024	9545-008-026	2
4	Panel Assy, Front	9454-810-001	9989-617-002	9989-617-002	9989-618-002	9989-618-002	1
*	Stop Button Mounting Plate	9452-725-001	9452-725-001	9452-725-001	9452-725-001	9452-725-001	1
5	Band, Edge Protector	9578-072-002	9578-092-002	9578-092-002	9578-092-002	9578-092-002	1
*	Bumper Loading Door	9051-055-001	9051-055-001	9051-055-001	9051-055-001	9051-055-001	1
*	Nut, 1/4 x 20 for bumper	8640-414-006	8640-414-006	8640-414-006	8640-414-006	8640-414-006	1
*	Screw, Hex- To Control Panel	9545-008-024	9545-008-024	9545-008-024	9545-008-024	9545-008-024	2
*	Nut, Spring- To Control Panel 10/32	8640-442-001	8640-442-001	8640-442-001	8640-442-001	8640-442-001	2
6	Screw, Flat Head- Front to Sides	9545-008-014	9545-008-014	9545-008-014	9545-008-014	9545-008-014	2
6	Screw, Flat Head- Front to Sides						4
6	Washer, Finish	8641-585-001	8641-585-001	8641-585-001	8641-585-001	8641-585-001	2
6	Washer, Finish						4
*	Nut, Spring-To Front Panel	8640-442-001	8640-442-001	8640-442-001	8640-442-001	8640-442-001	2
7	Label, Door Opening (Blue)	8502-723-001	8502-723-001	8502-723-001	8502-723-001	8502-723-001	1
7	Label, Door Opening (Black)	8502-742-001	8502-742-001	8502-742-001	8502-742-001	8502-742-001	1
8	Panel, Control (Mounts Nameplate)	9989-525-001	9989-525-001	9989-525-001	9989-525-001	9989-529-001	1
*	Screw, Control Panel to Sides	9545-008-026	9545-008-026	9545-008-026	9545-008-026	9545-008-026	4
9	Nameplate Decal, Control Blue	9412-162-001	9412-198-001	9412-191-001	9412-142-001	9412-193-001	1
	Nameplate Decal, Control Black		9412-199-001	9412-192-001	9412-173-001	9412-194-001	
10	Panel Top	9454-743-001	9454-736-002	9454-736-002			1
11A	Panel Top Front				9454-761-001	9454-850-001	1
11B	Panel Top Rear				9454-762-001	9454-851-001	1
12	Lock, Top (w/Key)	8650-012-003	8650-012-003	8650-012-003	8650-012-003	8650-012-003	2
13	Door, Lower Service, Includes Handle	9108-118-001	9960-286-004	9960-286-004	9960-286-004	9960-286-005	1
14	Handle (bumper guard)	9244-086-003	9244-086-003	9244-086-003	9244-086-003	9244-086-004	1
*	Rivet Blind 3/16" Alum	9491-009-003	9491-009-003	9491-009-003	9491-009-003	9491-009-003	4
*	Screw	9545-045-010	9545-045-010	9545-045-010	9545-045-010	9545-045-010	4
15	Screw Mtg., Flat Head 10Bx1 3/4	9545-008-014	9545-008-014	9545-008-014	9545-008-014	9545-008-014	2
16	Washer, Finish	8641-585-001	8641-585-001	8641-585-001	8641-585-001	8641-585-001	2
*	Nut, Spring	8640-442-001	8640-442-001	8640-442-001	8640-442-001	8640-442-001	2

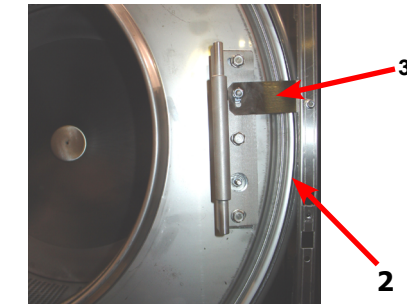
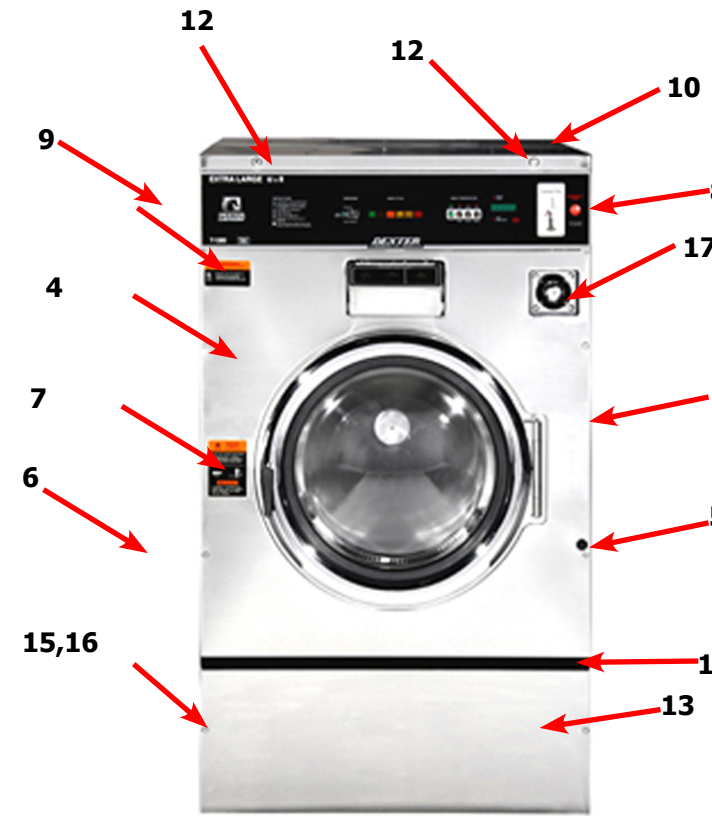

Key	Description	T-750	T-900	T950	T-1200	T1450	QTY
17	Coin Box assy, Large Blue	9807-099-002	9807-099-002	9807-099-002	9807-099-002	9807-099-002	1
17	Coin Box assy, Large Black	9807-099-004	9807-099-004	9807-099-004	9807-099-004	9807-099-004	1
*	Key, Top- # 6324	6292-006-007	6292-006-007	6292-006-007	6292-006-007	6292-006-007	1
*	Lock	8650-012-003	8650-012-003	8650-012-003	8650-012-003	8650-012-003	2
*	Cam, Lock-Top	9095-038-001	9095-038-001	9095-038-001	9095-038-001	9095-038-001	1
*	Nut, 9/32 - 28 Hex	8640-426-001	8640-426-001	8640-426-001	8640-426-001	8640-426-001	1
*	Washer Flat 5/16	8641-581-008	8641-581-008	8641-581-008	8641-581-008	8641-581-008	1
18	Coin Vault, S.S.	9942-037-001	9942-037-001	9942-037-001	9942-037-001	9942-037-001	1
18	Coin Vault, Black	9942-037-005	9942-037-005	9942-037-005	9942-037-005	9942-037-005	1
*	Screw, 10B x 1/2	9545-008-026	9545-008-026	9545-008-026	9545-008-026	9545-008-026	4
*	Chute, Coin	9119-031-001	9119-031-001	9119-028-001	9119-028-001	9119-028-001	1
*	Screw, Coin Schute	9545-008-001	9545-008-001	9545-008-001	9545-008-001	9545-008-001	2

## Cabinet and Front Panel Group Part # by Model Front Soap Dish

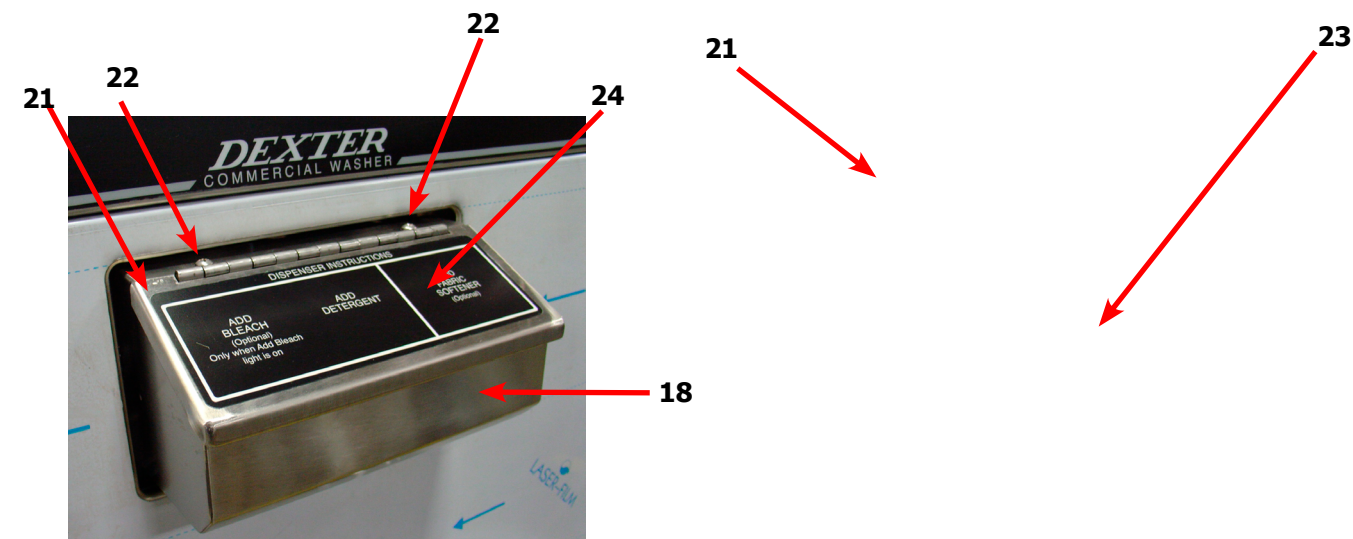
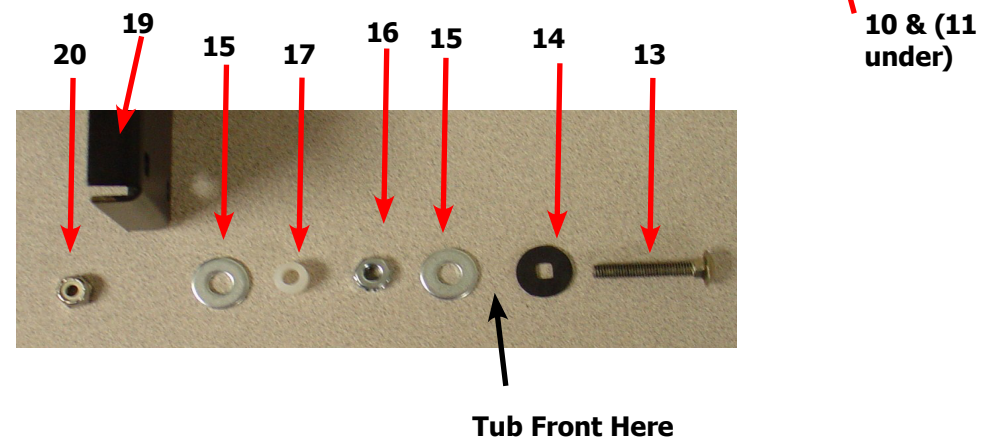
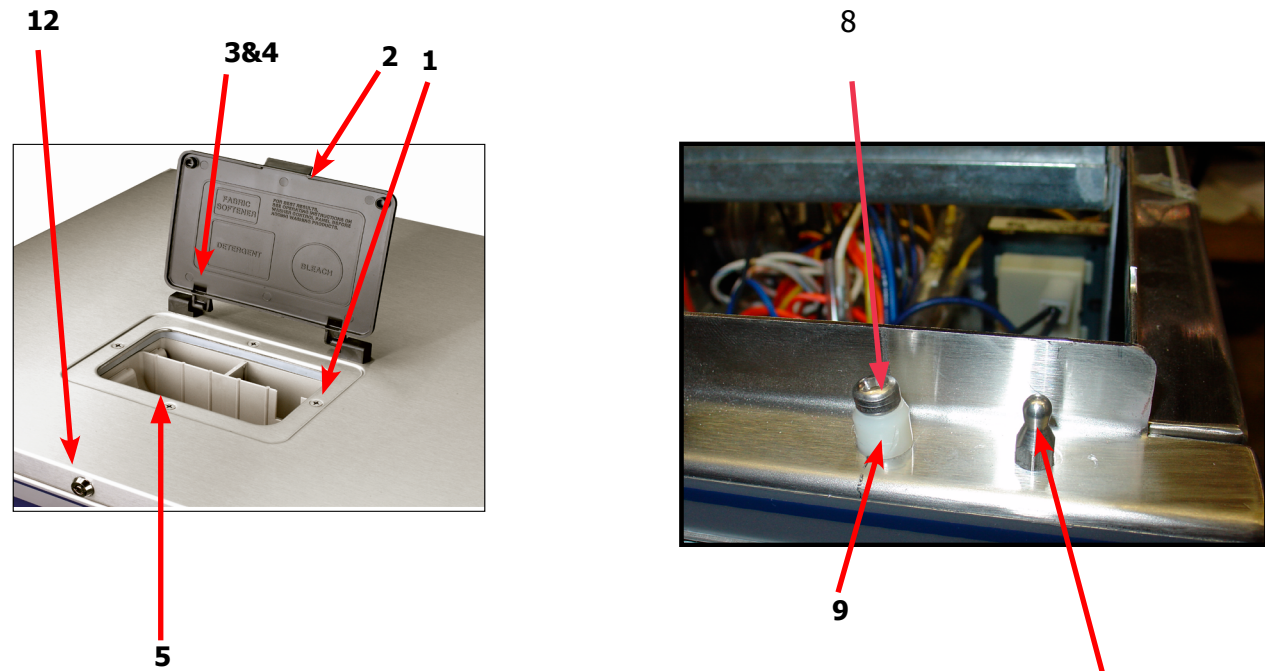

## Top Mount Detergent Dispenser

Key	Description	T-750	T-900	T-950	T-1200	T-1450	QTY
1	Dispenser Soap	9122-005-004	9122-005-004				1
*	Nut, Spring ss	8640-399-007	8640-399-007				4
*	Flow restrictors	9475-002-002	9475-002-002				
*	Flow restrictors Optional (Smaller)	9475-002-003	9475-002-003				
2	Door, Dispenser	9108-095-005	9108-095-005				1
3	Pin, Plain	9451-191-001	9451-191-001				2
4	Post, Door Mounting	9467-025-001	9467-025-001				2
5	Screw, SS Dispenser	9545-045-002	9545-045-002				4
*	Washer Flat 5/16	8641-581-008	8641-581-008	8641-581-008	8641-581-008	8641-581-008	1
8	Screw, Locator	9545-008-023	9545-008-023	9545-008-023	9545-008-023	9545-008-023	1
9	Plastic Sleeve, Locator	9355-001-001	9355-001-001	9355-001-001	9355-001-001	9355-001-001	1
10	Locator Post	9467-024-001	9467-024-001	9467-024-001	9467-024-001	9467-024-001	2
11	Nut, Locator Post	8640-411-003	8640-411-003	8640-411-003	8640-411-003	8640-411-003	2
*	Catch, Top Panel	9086-017-001	9086-017-001	9086-017-001	9086-017-001	9086-017-001	2
12	Lock, Top (w/Key)	8650-012-003	8650-012-003	8650-012-003			1
12	Lock, Top (w/Key)				8650-012-003	8650-012-003	2
*	Gasket Dispensor	9206-416-001	9206-416-001				
*	Hose, Dispensor to tub	9242-450-001	9242-450-001				1
*	Clamp	8654-117-008	8654-117-008				2

## Front Mount Detergent Dispenser

Key	Description	T-750	T-900	T-950	T-1200	T-1450	QTY
13	Bolt, #10-32 x 1 1/4"SS		9545-012-026	9545-012-026	9545-012-026	9545-012-026	6
14	Special Washer, Rubber		8641-222-000	8641-222-000	8641-222-000	8641-222-000	6
*	Tub Front		9974-011-002				1
15	Washer-Flat, 1/4		8641-581-018	8641-581-018	8641-581-018	8641-581-018	12
16	Nut, #10-32UNF		8640-413-002	8640-413-002	8640-413-002	8640-413-002	6
17	Spacer Plastic #10x1/2		9538-157-019	9538-157-019	9538-157-019	9538-157-019	6
18	Soap Dispenser (no lid)		9807-087-001	9807-087-001	9807-087-001	9807-087-001	1
*	Det. Dispenser Mtg Gasket to Tub frnt		9206-425-001	9206-425-001	9206-425-001	9206-425-001	1
19	Bracket Soap box mounting		9029-122-002	9029-122-002	9029-122-002	9029-122-002	1
20	Nut Hex Elasticstop #10-32 SS mtg dispenser		8640-413-006	8640-413-006	8640-413-006	8640-413-006	6
21	Lid Assembly dispenser		9987-104-001	9987-104-001	9987-104-001	9987-104-001	1
22	Lid screws #10-32x1/2 SS		9545-012-017	9545-012-017	9545-012-017	9545-012-017	2
23	Softner siphon tube (plastic)		9574-252-002	9574-252-002	9574-252-002	9574-252-002	1
*	Flow restrictors		9475-002-003	9475-002-003	9475-002-003	9475-002-003	AR
24	Washer Dispenser Label Blue		8502-687-001	8502-687-001	8502-687-001	8502-687-001	1
24	Washer Dispenser Label Black		8502-745-001	8502-745-001	8502-745-001	8502-745-001	1

# Rear View Access Part # by Model

Key	Description	T-750	T-900	T-950	T-1200	T-1450	QTY
1	Drive Motor, 3 Phase	9376-298-001	9376-308-001	9376-298-001	9376-298-001	9376-326-001	1
1	Drive Motor After serial #553489	9376-329-001		9376-329-001	9376-329-001		1
2	Rod, Motor Mtg	9497-222-004	9497-222-004	9497-222-004	9497-222-004	9497-222-004	1
3	Collar, Shaft (w/set screws) (old)	9076-052-002	9076-052-002		9076-052-002	9076-052-002	2
*	Motor Bushing (plastic)	9053-074-001	9053-074-001	9053-074-001	9053-074-001	9053-074-001	1
4	New motor bushing support	9053-082-001	9053-082-001	9053-082-001	9053-082-001	9053-082-001	2
5	Clamp for motor bushing	8654-117-019	8654-117-019	8654-117-019	8654-117-019	8654-117-019	2
6	Pulley, Motor	9453-179-001	9453-175-002	9453-175-002	9453-175-002	9453-175-002	1
*	Split TaperBushing (motor pulley)	9053-077-001	9053-077-001	9053-077-001	9053-077-001	9053-077-001	1
*	Screw taper bushing 1/4-20x1	9545-018-024	9545-018-024	9545-018-024	9545-018-024	9545-018-024	3
7	Bolt, Eye (1/4"-20x1/2")	9545-055-001	9545-055-001	9545-055-001	9545-055-001	9545-055-001	1
*	Nut, 1/4 Elastic Stop	8640-414-003	8640-414-003	8640-414-003	8640-414-003	8640-414-003	1
*	Link (open end)	9341-046-001	9341-046-001	9341-046-001	9341-046-001	9341-046-001	1
8	Chain (Spring Tension)	9099-012-003	9099-012-003	9099-012-003	9099-012-004	9099-012-004	1
9	Spring, Belt Tension	9534-151-000	9534-151-000	9534-151-000	9534-151-000	9534-151-000	1
10	Pulley, Driven	9453-173-002	9453-176-005	9453-176-005	9453-176-005	9453-176-005	1
*	Tolerance Ring	9487-234-004					1
*	Screw, 5/8"-11 x 2"	9545-060-004					1
*	Washer-Flat, 5/8"	8641-582-032					1
*	Washer-Flat, 5/8"	8641-582-018					1
11	Bolt, 3/8"-16 x 2"		9545-029-011	9545-029-011	9545-029-011	9545-029-011	3
12	Washer, 3/8"		8641-582-003	8641-582-003	8641-582-003	8641-582-003	3
*	Bushing Taperlock (Pulley)		9053-078-002	9053-078-002	9053-078-002	9053-078-002	1
13	Washer-Flat .675x2-1/2x1/4	8641-581-043	8641-581-043	8641-581-043	8641-581-043		1
14	Lockwasher-Exttooth, 5/8	8641-582-018	8641-582-018	8641-582-018	8641-582-018		1
15	Bolt, 5/8-11x1 1/2	9545-060-001	9545-060-001	9545-060-001	9545-060-001		1
13	Washer-Flat, .781x2-1/2x1/4					8641-581-044	1
14	Lockwasher-Exttooth, 3/4					8641-582-020	1
15	Bolt, 3/4-10-1 1/2					9545-057-004	1
16	Drive Belt		9040-079-002	9040-079-002	9040-079-003	9040-079-006	1
16	Drive Belt	9040-076-008					2
17	Hose, Overflow to drain	9242-449-003	9242-449-003	9242-449-003	9242-449-003	9242-449-005	1
18	Clamp, Hose overflow to drain	8654-117-018	8654-117-018	8654-117-018	8654-117-018	8654-117-018	2
19	Hose, Overflow Vent Top	9242-463-004	9242-463-004	9242-463-004	9242-463-004	9242-463-004	
*	Clamp, Hose Vent	8654-117-008	8654-117-008	8654-117-008	8654-117-008	8654-117-008	1
*	Vacuum Breaker ALL	9610-001-001	9610-001-001	9610-001-001	9610-001-001	9610-001-001	1
*	Clamp, Hose to Vacuum Breaker	8654-117-014	8654-117-014	8654-117-014	8654-117-014	8654-117-014	1
20	Hose, Vacuum Breaker to tub	9242-458-003	9242-458-003	9242-458-003	9242-458-003	9242-458-003	1
*	Vacuum Breaker Bracket	9029-069-001	9029-069-001	9029-069-001	9029-069-001	9029-069-001	1
21	Inlet Cap		0935-135-001	0935-135-001			2
22	Hose, Pressure Switch	9242-175-007	9242-175-007	9242-175-007	9242-175-004	9242-175-004	1
*	Clamp, Overflow Hose	8654-117-015	8654-117-015	8654-117-015	8654-117-015	8654-117-015	1
23	VFD Delta "S" drive 208-240 volt	9732-345-009	9732-345-004		9732-345-005		1
23	"S" Drive After serial #553489	9375-014-023			9375-014-025		
23	VFD Delta "E" drive 208-240 volt			9375-028-002		9375-029-002	
23	"E" Drive After serial #553489			9375-028-006			
24	Braking resistors (160 ohm)	9483-004-003	9483-004-003		9483-004-003		2
*	Bracket assembly (drive mount)	9029-157-001	9029-157-001	9029-212-001	9029-150-001	9029-216-001	1
25	Channel, Rear, Before Serial #	9081-148-001	9081-148-001		9081-140-001		1
25	Channel, Rear, After Serial #		9081-152-001	9081-152-002		9081-153-001	1

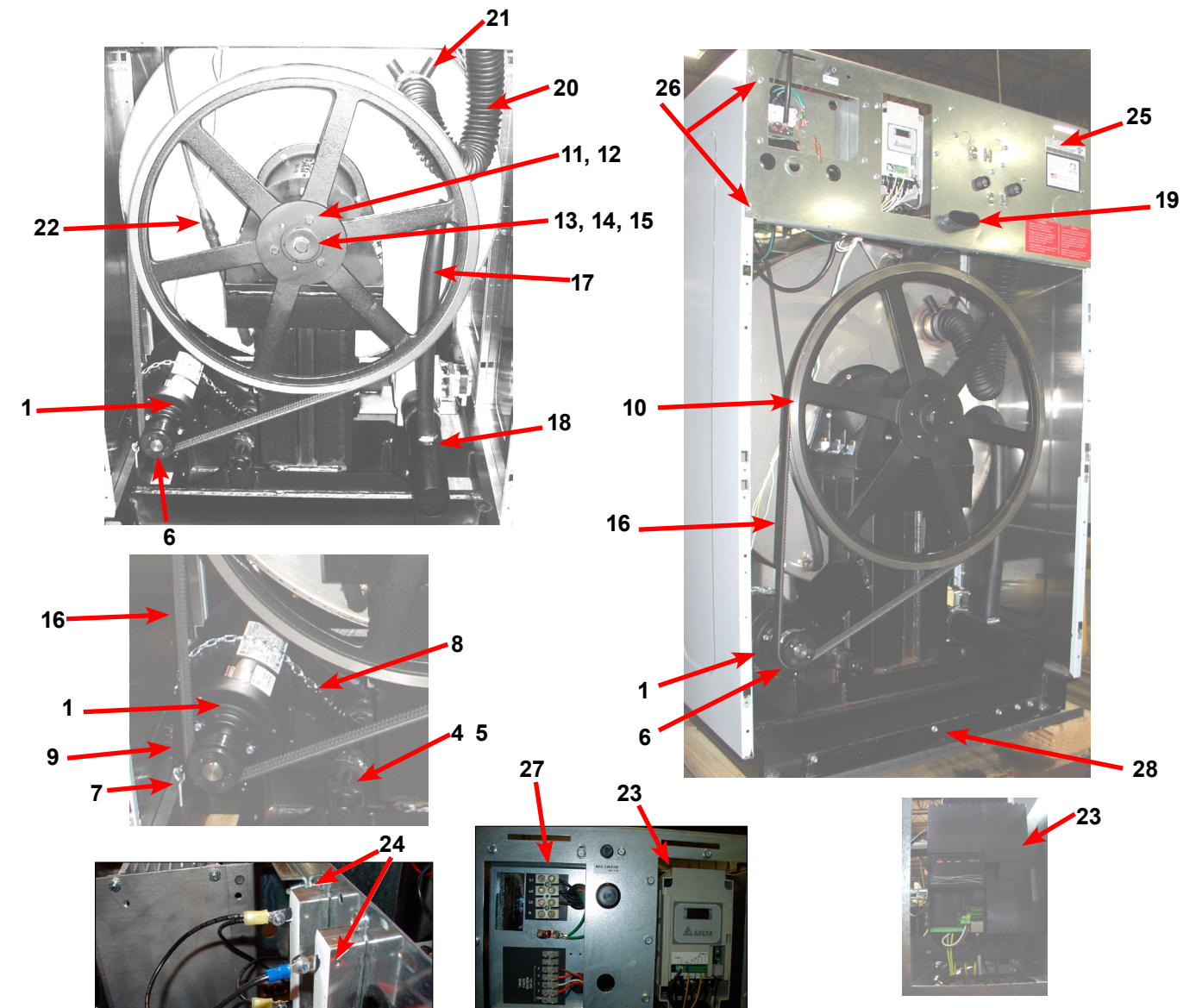

Key	Description	T-750	T-900	T-950	T-1200	T-1450	QTY
26	Screw #10Bx1/2	9545-008-026	9545-008-026	9545-008-026	9545-008-026	9545-008-026	4
*	Nut, Spring	8640-399-007	8640-399-007	8640-399-007	8640-399-007	8640-399-007	4
*	Cover, Terminal Block		9074-267-001	9074-267-001	9074-267-001	9074-267-001	1
*	Screw #10Bx1/2	9545-008-026	9545-008-026	9545-008-026	9545-008-026	9545-008-026	1
-*	Cover, VFD, Before Serial #935659	9074-278-001	9074-278-001	9074-278-001	9074-278-001	9074-278-001	1
*	Cover, VFD, After Serial #935659		9074-342-001	9074-342-001	9074-299-001	9074-299-001	1
*	Screw #10Bx1/2	9545-008-026	9545-008-026	9545-008-026	9545-008-026	9545-008-026	1
27	Terminal Block, Channel Mount		9897-033-002	9897-033-002	9897-033-002	9897-033-002	1
*	Panel Assy., Back Before Serial #535659	9989-455-001	9989-455-001		9989-491-001		1
*	Panel Assy., Back After Serial #535659		9989-526-001	9989-526-001			1
*	Panel Assy., Back, Upper					9454-873-001	
*	Panel Assy., Back, Lower					9454-872-001	
*	Screw Panel Mtg.#10Bx1/2"	9545-008-026			9545-008-026	9545-008-026	10
*	Screw Panel Mtg.#10Bx1/2"		9545-008-026	9545-008-026			9
*	Screw Panel Mtg.#10Bx1/2"						13
*	Nut, Spring	8640-399-007	8640-399-007	8640-399-007	8640-399-007	8640-399-007	AR
28	Screw, To Base-1/4" x 3/4"	9545-030-002	9545-030-002	9545-030-002	9545-030-002	9545-030-002	3

# Cylinder, Seals & Bearings Part # by Model

Key	Description	T-750	T-900	T-950	T-1200	T-1450	QTY
*	Bearings and Seal Kit	9732-219-007	9732-219-007	9732-219-007	9732-219-007	9732-219-009	1
*	Housing, Bearing- Assembly (items #2-#6)	9803-187-001	9803-187-001	9803-187-001	9803-187-001	9803-209-001	1
2	Housing, Bearing	9241-181-004	9241-181-004	9241-181-004	9241-181-004	9241-195-003	1
3	Bearing, Front (LARGE)	9036-159-006	9036-159-006	9036-159-006	9036-159-006	9036-162-002	1
4	Bearing, Rear (SMALL)	9036-159-005	9036-159-005	9036-159-005	9036-159-005	9036-162-001	1
5	Spacer, Bearing	9538-170-001	9538-170-001	9538-170-001	9538-170-001	9538-185-001	1
6	Ring, Bearing Retainer	9487-238-004	9487-238-004	9487-238-004	9487-238-004	9487-238-004	1
8	Seal, Small V85A	9532-140-007	9532-140-007	9532-140-007	9532-140-007		1
8	Seal, Small V95A					9532-140-012	
9	Seal, Large V140A	9532-140-008	9532-140-008	9532-140-008	9532-140-008	9532-140-008	1
10	Ring, Seal Mounting	9950-052-001	9950-052-001	9950-052-001	9950-052-001	9950-062-001	1
11	Tub Back Mating Ring	9487-261-004	9487-261-004	9487-261-004	9487-261-004	9487-261-005	1
11G	Mating Ring Guard Shield	9487-266-001		9487-266-001		9487-276-001	1
12	Bolt, Tub End of Bearing Housing (7/16-14x1), Bolt from inside Tub	9545-059-004	9545-059-004	9545-059-004	9545-059-004	9545-059-004	6
13	Washer, Flat	8641-581-034	8641-581-034	8641-581-034	8641-581-034	8641-581-034	6
14	Screw-Hex Cap, 3/4"-10 x 3" (Bearing Housing to Frame)	9545-057-002	9545-057-002	9545-057-002	9545-057-002		6
14	Screw-Hex Cap, 7/8"-10 x 3" (Bearing Housing to Frame)					9545-066-001	6
15	Washers Spherical 3/4 (Male half) (Bearing Housing to Frame)	8641-588-001		8641-588-001	8641-588-001		6
15	Washers Spherical 7/8 (Male half) (Bearing Housing to Frame)					8641-588-003	
16	Washers Spherical 3/4 (Female half) (Bearing Housing to Frame)	8641-588-002		8641-588-002	8641-588-002		6
16	Washers Spherical 7/8 (Female half) (Bearing Housing to Frame)					8641-588-004	6
15	Washer, Flat		8641-581-033				6
16	Lock Washer-External Tooth, 3/4" (Bearing Housing to Frame)		8641-582-020				6
17	Nut 3/4"-10 (Bearing Housing to Frame)	8640-418-003	8640-418-003	8640-418-003	8640-418-003		6
17	Nut 7/8"-9 (Bearing Housing to Frame)					8640-437-001	6
18	Pulley, Driven	9453-173-002	9453-176-005	9453-176-005	9453-176-005	9453-176-005	1
*	Tolerance Ring	9487-234-004					1
*	Screw, 5/8"-11 x 2"	9545-060-004					1
*	Washer-Flat, 5/8"	8641-582-032					1
*	Washer-Flat, 5/8"	8641-582-018					1
19	Bolt, 3/8"-16 x 2"		9545-029-011	9545-029-011	9545-029-011	9545-029-011	3
20	Washer, 3/8"		8641-582-003	8641-582-003	8641-582-003	8641-582-003	3
21	Bushing Taperlock (Driven & Large)		9053-078-002	9053-078-002	9053-078-002	9053-078-002	1
22	Washer-Flat .675x2-1/2x1/4	8641-581-043	8641-581-043	8641-581-043	8641-581-043		1
23	Lockwasher-Exttooth, 5/8	8641-582-018	8641-582-018	8641-582-018	8641-582-018		1
24	Bolt, 5/8-11x1 1/2	9545-060-001	9545-060-001	9545-060-001	9545-060-001		1
22	Washer-Flat, .781x2-1/2x1/4					8641-581-044	1
23	Lockwasher-Exttooth, 3/4					8641-582-020	1
24	Bolt, 3/4-10-1 1/2					9545-057-004	1
25	Tub & Cylinder Assy Before Serial #535659	9869-025-002	9869-023-002		9869-022-002		1
25	Tub & Cylinder Assy After Serial #535659		9869-027-002	9869-027-002		9869-026-001	1
*	Cylinder Assy	9848-136-002	9848-136-001	9848-136-001	9848-137-001	9848-141-001	1

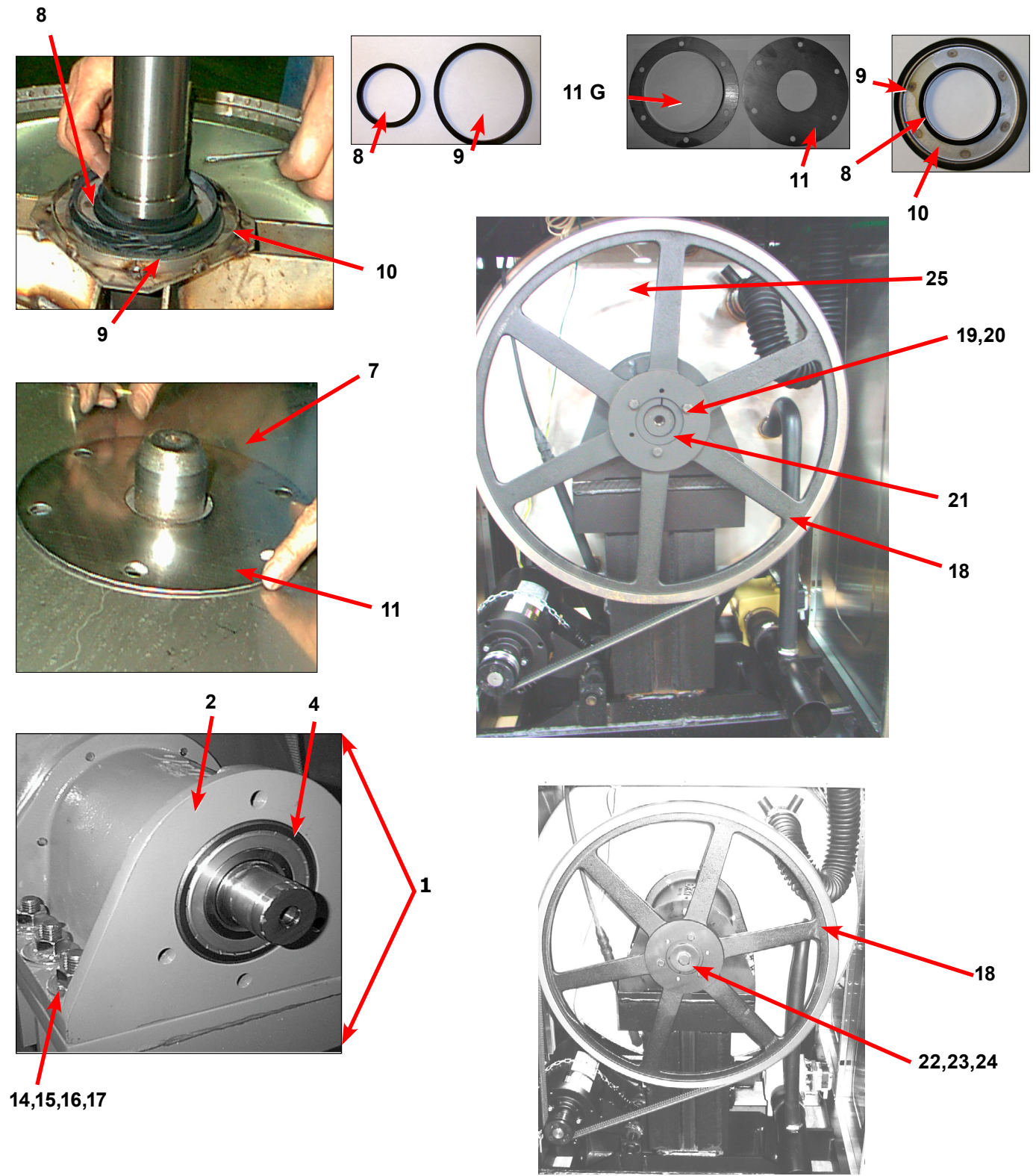

Key	Description	T750	T-900	T950	T-1200	T1450	QTY
*	Tub Front Before Serial #535659	9974-011-002	9178-148-001		9974-011-002		1
*	Tub Front After Serial #535659		9974-011-002	9974-011-002		9178-056-001	1
*	Gasket, Tub Front		9206-421-002	9206-421-002	9206-421-002	9206-421-003	1
*	Ring Assy, Tub Mtg-Front Clamp	9950-055-001	9950-055-001	9950-055-001	9950-055-001	9950-061-001	1
*	Bolt, Top Front Ring 3/8"-16 x 3"	9545-029-009	9545-029-009	9545-029-009	9545-029-009	9545-029-009	1
*	Nut WCAD 3/8"-16	8640-415-001	8640-415-001	8640-415-001	8640-415-001	8640-415-001	1

## Door Latching Assembly (All Models)

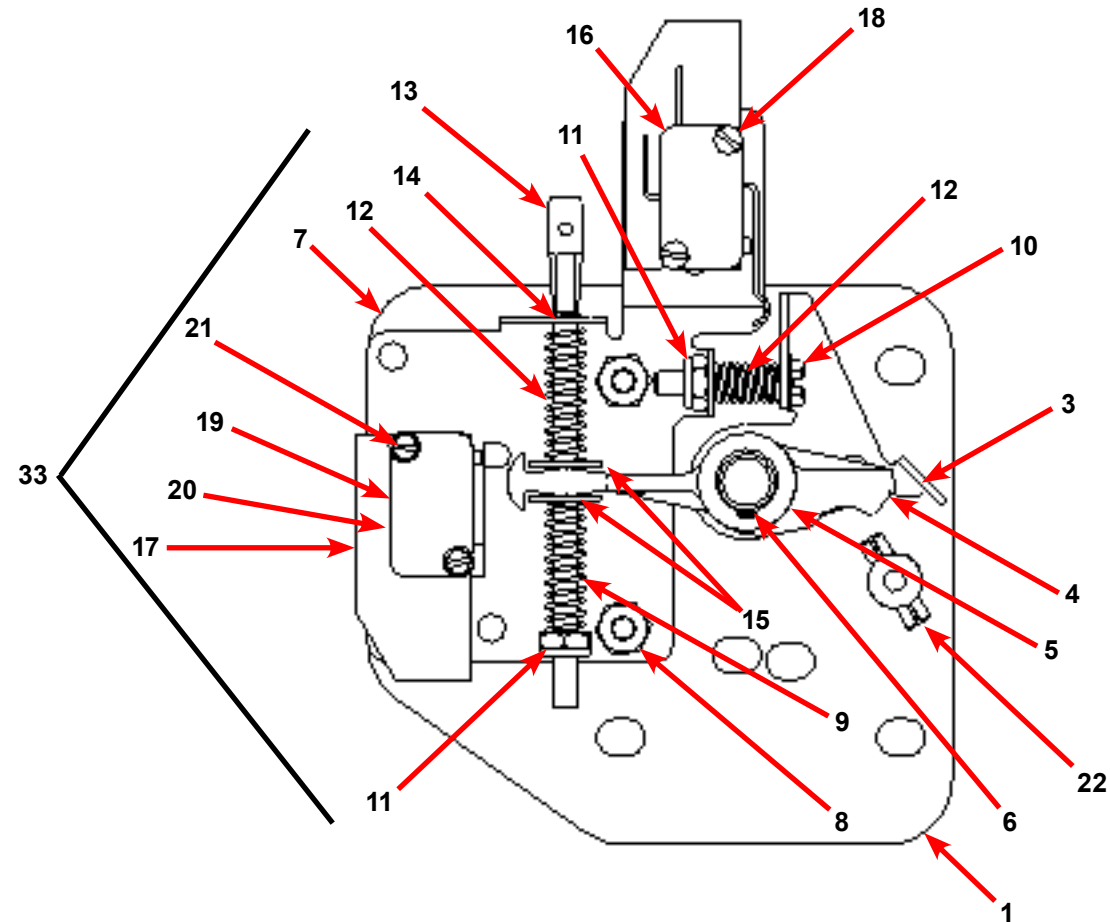

Key	Description	All Models	QTY
33	Latching Assy, Complete (includes #1 thru #22)	9885-024-001	1
1	Plate Assy, Door Lock	9982-346-001	1
2	Washer, Flat (SS or Brass)	8641-581-030	1
3	Actuator, Latching Switch	9008-005-001	1
4	Pawl, Locking	9732-346-002	1
5	Washer, Spring	8641-569-003	1
6	Ring, Retaining	9487-200-004	1
7	Bracket Switch	9029-163-001	1
8	Nut, Hex 10-32 UNF	8640-413-002	2
9	Spring, Actuating	9534-364-002	1
10	Screw, Hx. 10-32 x 1"	9545-012-020	1
11	Nut, Elastic Stop 10-32	8640-413-004	2
12	Spring, Return	9534-364-001	2
13	Pin, Guide	9451-193-001	1

Key	Description	All Models	QTY
14	Ring, Retaining	9487-200-005	1
15	Washer	8641-581-031	1
16	Switch, Latching Sensing	9539-461-008	1
17	Shield, Switch	9550-169-003	3
18	Screw 4-40 x 5/8"	9545-020-001	2
18	Nut, Twin 4-40	8640-401-001	1
19	Switch, Locking Sensing	9539-461-007	2
20	Actuator, Switch Locking	9008-006-003	1
21	Screw 4-40 x 1 1/8"	9545-020-003	2
21	Nut, Twin 4-40	8640-401-001	1
22	Spacer Sensor	9538-182-001	1
23	Pin, Dowel	9451-181-004	1
*	Shim, Door Lock, Thin	9552-037-001	AR
*	Screw, Lock mtg 1/4"-20 x 3/4"	9545-018-014	3
*	Lockwasher 1/4" Ext tooth	8641-582-007	3
*	Door Stud Pin, 3/16" x 3/4"	9451-181-004	1

## Gear Motor Door Lock Assembly

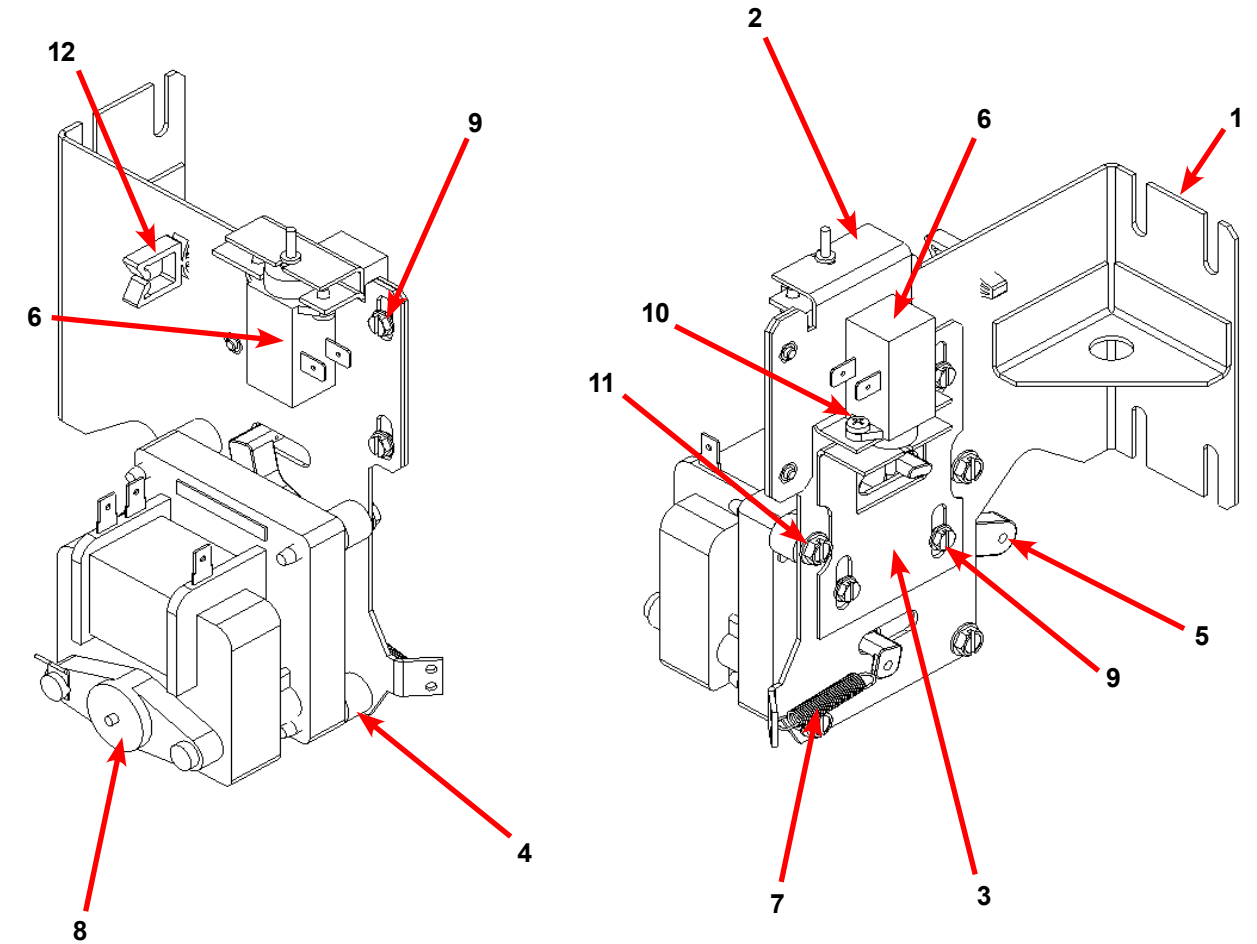

Key	Description	T-750	T-900	T-950	T-1200	T-1450	QTY
*	Actuator Assembly (Includes 1-10, Rod NOT included)	9892-015-001	9892-015-001	9892-015-001	9892-015-001	9892-015-001	1
11	Screw-hxwshdsl, 10-24-1.25f, ctd	9545-046-007	9545-046-007	9545-046-007	9545-046-007	9545-046-007	4
10	Cross Recessed PAN Hd Tapping screw	9545-031-011	9545-031-011	9545-031-011	9545-031-011	9545-031-011	4
9	Screw -Hxwshrhdslsems, 6-32 x 3/16	9545-044-003	9545-044-003	9545-044-003	9545-044-003	9545-044-003	6
8	Motor & Gear Assembly 120v	9914-137-011	9914-137-011	9914-137-011	9914-137-011	9914-137-011	1
7	Spring - Extension	9534-350-001	9534-350-001	9534-350-001	9534-350-001	9534-350-001	1
6	Thermoactuator - Door Lock Relay 120v	9586-001-001	9586-001-001	9586-001-001	9586-001-001	9586-001-001	2
5	Arm - Door Lock	9001-063-001	9001-063-001	9001-063-001	9001-063-001	9001-063-001	1
4	Spacer, Plastic	9538-157-021	9538-157-021	9538-157-021	9538-157-021	9538-157-021	4
3	Bracket Slide Lock	9029-204-001	9029-204-001	9029-204-001	9029-204-001	9029-204-001	1
2	Bracket Assy, Slide - Unlock	9985-189-001	9985-189-001	9985-189-001	9985-189-001	9985-189-001	1
1	Bracket Assy, Slide Lock Actuator	9985-190-001	9985-190-001	9985-190-001	9985-190-001	9985-190-001	1
*	Rod, Door Lock Before Serial #535659	9497-225-013	9497-225-013				1
*	Rod, Door Lock After Serial #535659		9497-225-015	9497-225-015	9497-225-015	9497-225-016	1
*	Spacer, Gear Motor	9538-187-001	9538-187-001	9538-187-001	9538-187-001	9538-187-001	1

# Original Door Lock Solenoid Assembly

Key	Description	T-750	T-900	T-950	T-1200	T-1450	QTY
1	Solenoid Ass'y, Door Locking (includes 23 thru 32)	9922-011-001	9922-011-001		9922-011-001		1
2	Bracket, (Door Locking Solenoid)	9029-073-001	9029-073-001		9029-073-001		1
3	Bracket Ass'y, Solenoid Slide	9985-169-001	9985-169-001		9985-169-001		1
4	Solenoid 120V 60 hz	9536-074-001	9536-074-001		9536-074-001		1
5	Screw, Solenoid Mtg	9545-008-001	9545-008-001		9545-008-001		4
6	Stop, Door Lock Solenoid	9540-033-002	9540-036-001		9540-033-002		1
7	Screw, Shoulder	9545-061-001					1
*	Nut, Keps #6	8640-411-002	8640-411-002		8640-411-002		1
9	Thermoactuator 120 V	9586-001-001	9586-001-001		9586-001-001		2
10	Screw #6 x 5/16"	9545-031-011	9545-031-011		9545-031-011		4
11	Spacer, Plastic	9538-157-004	9538-157-004		9538-157-004		1
12	Spacer, Metal	9538-166-004	9538-166-004		9538-166-004		1
13	Screw, Cross Recessed	9545-010-001	9545-010-001		9545-010-001		1
14	Nut, Keps #8	8640-412-005	8640-412-005		8640-412-005		1
*	Nut, Sol. Brkt. to Control Panel	8640-412-005	8640-412-005		8640-412-005		3
*	Rod, Pull	9497-225-007	9497-225-007		9497-225-009		1

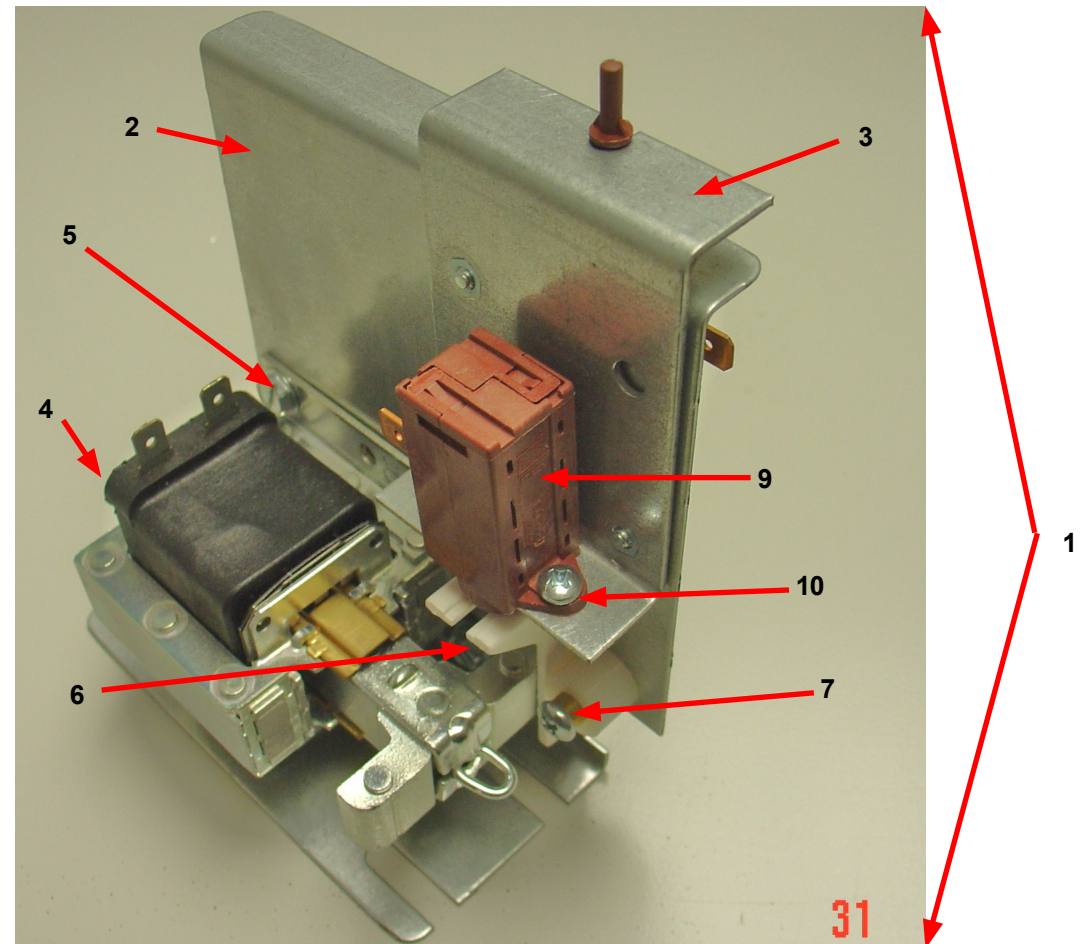

# Original Door Lock Solenoid Assembly

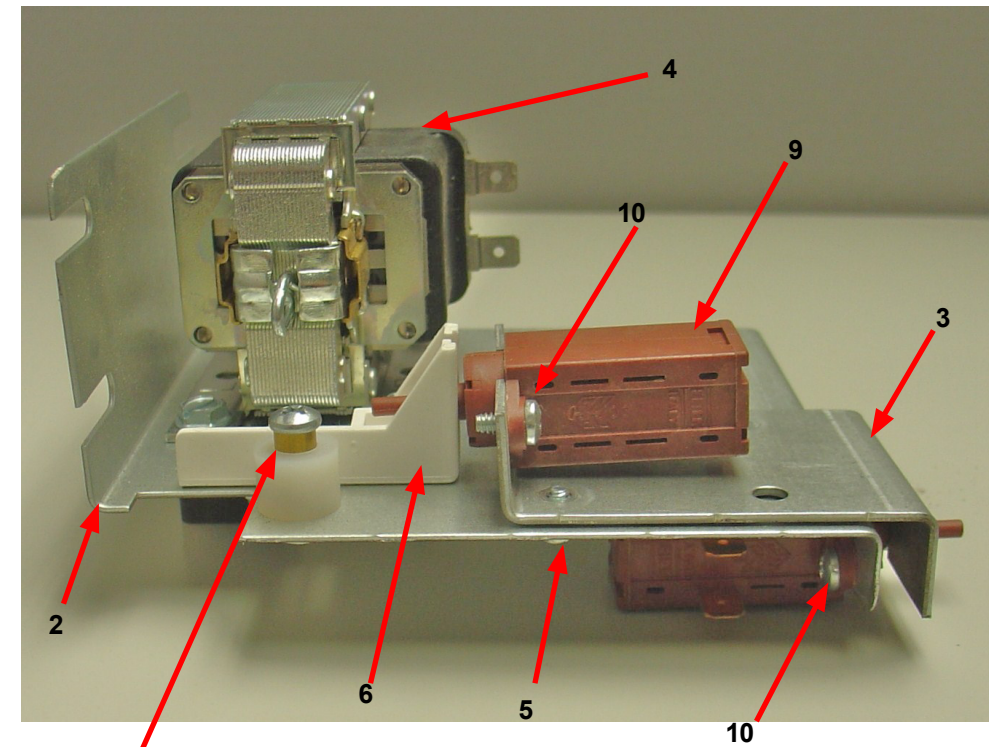

## Large Door & Hinge Group (After #514975)

Key	Description	T-750	T-900	T-950	T-1200	T-1450	QTY
1	Door Hinge Assembly (mounts to tub front)	9955-031-001	9955-031-001	9955-031-001	9955-031-001	9955-031-001	1
*	Door Assembly Complete	9960-274-005	9960-274-005	9960-274-005	9960-274-005	9960-274-005	1
2	Door Ring 180 degree large hinge	9487-275-001	9487-275-001	9487-275-001	9487-275-001	9487-275-001	1
3	Door Gasket	9206-431-001	9206-431-001	9206-431-001	9206-431-001	9206-431-001	1
4	Door Glass Window	9635-020-001	9635-020-001	9635-020-001	9635-020-001	9635-020-001	1
*	Red Wire (Door Close Switch)	8220-063-028	8220-063-028	8220-063-028	8220-063-028	8220-063-028	1
	Black Wire (Door Close Switch)	8220-063-029	8220-063-029	8220-063-029	8220-063-029	8220-063-029	1
5	Switch, Door Hinge Close (Plunger)	9539-492-001	9539-492-001	9539-492-001	9539-492-001	9539-492-001	1
6	Top Door Hinge Leaf (No pin)	9845-006-001	9845-006-001	9845-006-001	9845-006-001	9845-006-001	1
7	Bottom Door Hinge Leaf	9845-007-001	9845-007-001	9845-007-001	9845-007-001	9845-007-001	1
8	Thrd Form Screw, Door Mtg 5/16" x 5/8"	9545-056-002	9545-056-002	9545-056-002	9545-056-002	9545-056-002	4
9	Screw, Loading Door Hinge Mtg (5/16" x9/16" ss)	9545-014-013	9545-014-013	9545-014-013	9545-014-013	9545-014-013	3
10	Bracket Retainer support side panel	9046-085-001	9046-085-001	9046-085-001	9046-085-001	9046-085-001	1
*	Shim Large door	9552-043-001	9552-043-001	9552-043-001	9552-043-001	9552-043-001	1

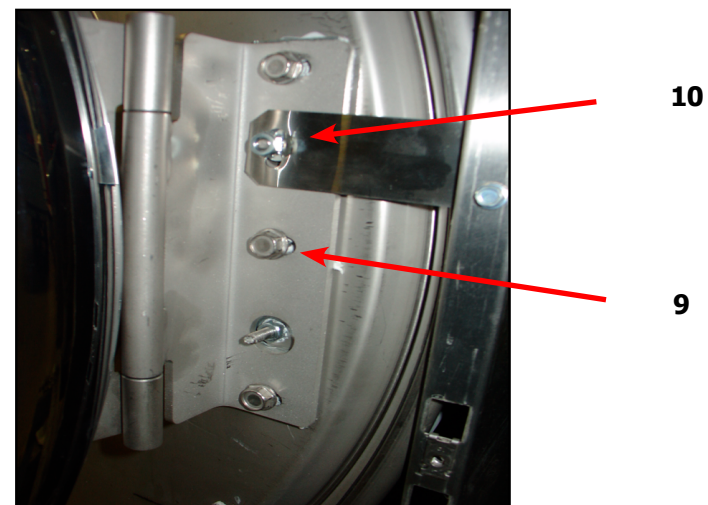

Key	Description	T750	T-900	T950	T-1200	T1450	QTY
11	Shaft, Door Locking	9537-195-002	9537-195-002	9537-195-002	9537-195-002	9537-195-002	1
12	Cam, Locking	9095-040-002	9095-040-002	9095-040-002	9095-040-002	9095-040-002	1
13	Pin, Groove (1 1/4)	9451-181-005	9451-181-005	9451-181-005	9451-181-005	9451-181-005	1
14	Pin, Groove (3/4)	9451-181-004	9451-181-004	9451-181-004	9451-181-004	9451-181-004	1
15	Spring, Lock Cam	9534-360-002	9534-360-002	9534-360-002	9534-360-002	9534-360-002	1
16	Handle, Door	9244-080-003	9244-080-003	9244-080-003	9244-080-003	9244-080-003	1
17	Pin, Door Handle (groove)	9451-181-006	9451-181-006	9451-181-006	9451-181-006	9451-181-006	1

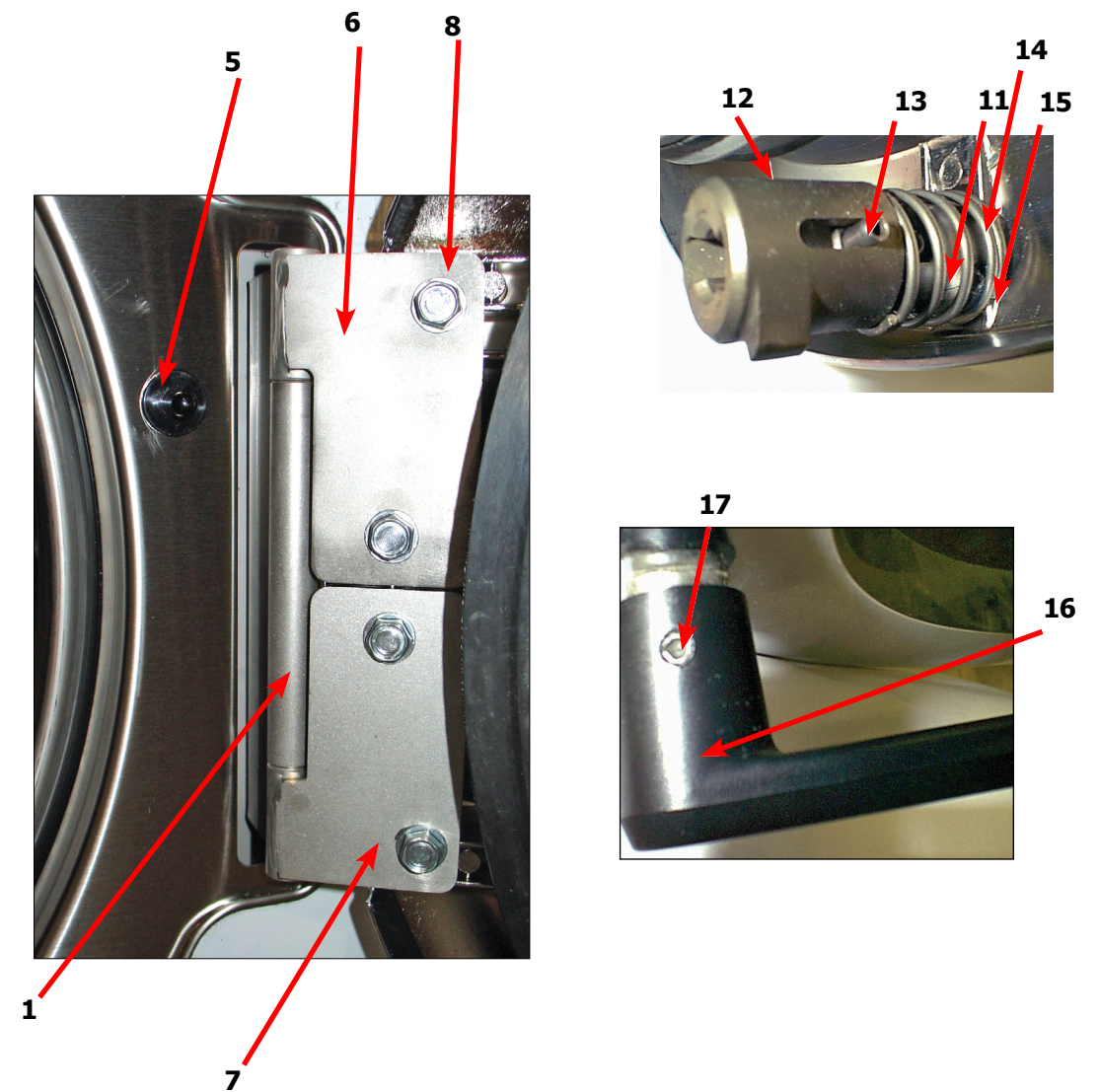

# WCAD75 180-Degree Door & Hinge Group

(Before #514975)

Key	Part Number	Description.....	Qty
*	9960-274-004	Loading Door, Complete ( includes #1thru #10) .....	1
1	9487-265-002	Loading Door Ring 180 degree.....	1
2	9206-419-001	Gasket, Loading Door.....	1
3	9635-016-001	Window, Loading Door.....	1
4	9913-134-003	Shaft Assy. Locking (includes #5 thru #8).....	1
5	9537-195-002	Shaft, Door Locking.....	1
6	9095-040-001	Cam, Locking.....	1
7	9451-181-005	Pin, Groove (1 1/4).....	1
8	9451-181-005	Pin, Groove (3/4).....	1
9	9534-360-002	Spring, Lock Cam.....	1
10	9244-080-003	Handle, Door.....	1
17	9451-181-006	Roll Pin, Door Handle (groove).....	1
11	9955-030-001	Hinge Assy, Loading Door ( mounts to tub front ).....	1
*	9545-014-009	Screw, Hinge Mtg.....	3
*	8641-582-009	Lockwasher.....	3
*	9552-036-001	Shim, Loading Door Hinge, Thin.....	AR
*	9552-036-002	Shim, Loading Door Hinge, Thick.....	AR
12	9845-005-003	Top, Loading Door Leaf Hinge with pin.....	1
13	9845-005-002	Bottom, Loading Door Leaf Hinge.....	1
16	9545-056-002	Screw, Loading Door Hinge Mtg.....	3
15	9950-060-002	Ring, Masking w door switch hole.....	1
*	8640-413-002	Nut.....	4
*	9059-063-002	Band Edge Protector.....	1
*	9801-089-001	Door Closure Switch Assembly.....	1
D1	9041-087-001	Switch Box.....	1
*	9053-067-003	Bushing Insulating.....	1
D3	9539-461-007	Switch, Micro.....	1
D2	9550-159-001	Switch, Shield.....	1
D4	8640-401-001	Nut Special Twin #4-40.....	1
D8	9545-020-001	Screw 4-40x5/8.....	2
D7	9008-004-001	Door Switch Actuator.....	1

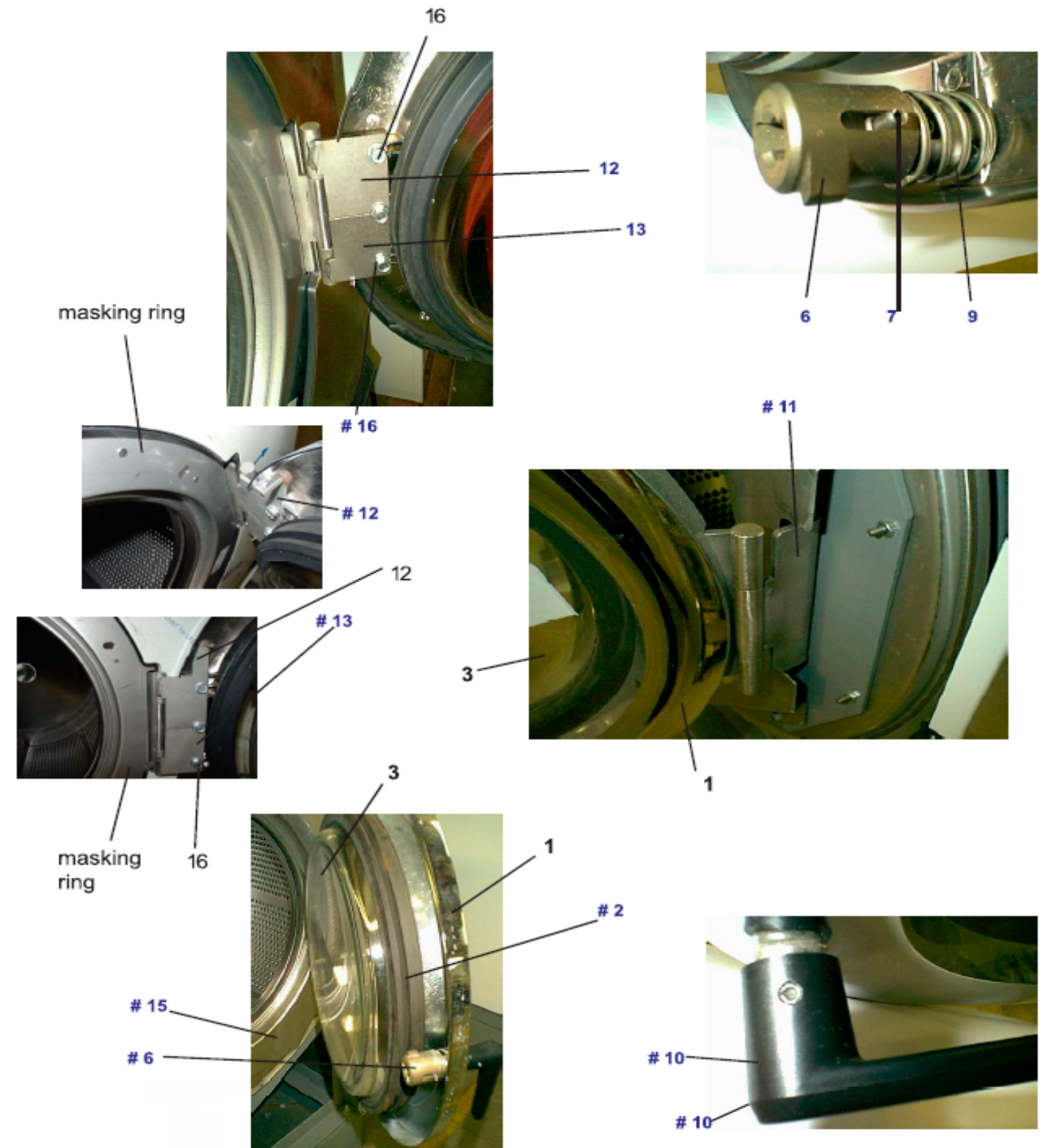
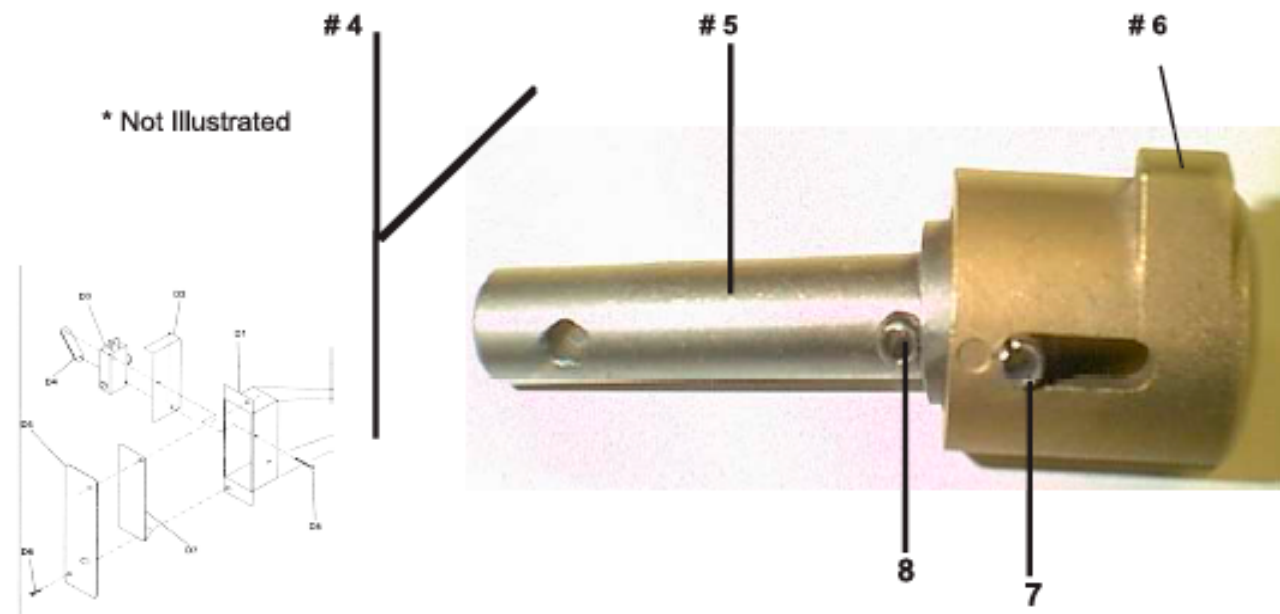

# Door & Hinge Group

(Before #514975)

Key	Part Number	Description.....	Qty
*	9960-274-002	Loading Door, Complete ( includes #1thru #10) .....	1
1	9487-265-001	Loading Door Ring.....	1
2	9206-419-001	Gasket, Loading Door.....	1
3	9635-016-001	Window, Loading Door.....	1
4	9913-134-003	Shaft Assy. Locking (includes #5 thru #8).....	1
*	9537-195-002	Shaft, Door Locking.....	1
5	9095-040-001	Cam, Locking.....	1
6	9451-181-005	Pin, Groove (1 1/4).....	1
7	9451-181-005	Pin, Groove (3/4).....	1
8	9534-360-002	Spring, Lock Cam.....	1
9	9244-080-003	Handle, Door.....	1
*	9451-181-006	Roll Pin, Door Handle (groove).....	1
10	9955-029-002	Hinge Assy, Loading Door ( mounts to tub front ).....	1
*	9545-014-009	Screw, Hinge Mtg.....	3
*	8641-582-009	Lockwasher.....	3
*	9552-036-001	Shim, Loading Door Hinge, Thin.....	AR
12	9938-040-002	Hinge Clamp assembly w/ pin.....	1
13	9545-056-003	Screw, Loading Door Hinge Mtg.....	3
14	9950-060-001	Ring, Masking w door switch hole.....	1
*	8640-413-002	Nut.....	4
*	9059-063-002	Band Edge Protector.....	1
*	9801-089-001	Door Closure Switch Assembly.....	1
D1	9041-087-001	Switch Box.....	1
*	9053-067-002	Bushing Insulating.....	1
D3	9539-461-007	Switch, Micro.....	1
D2	9550-159-001	Switch, Shield.....	1
D4	8640-401-001	Nut Special Twin #4-40.....	1
D8	9545-020-001	Screw 4-40x5/8.....	2
D7	9008-004-001	Door Switch Actuator.....	1

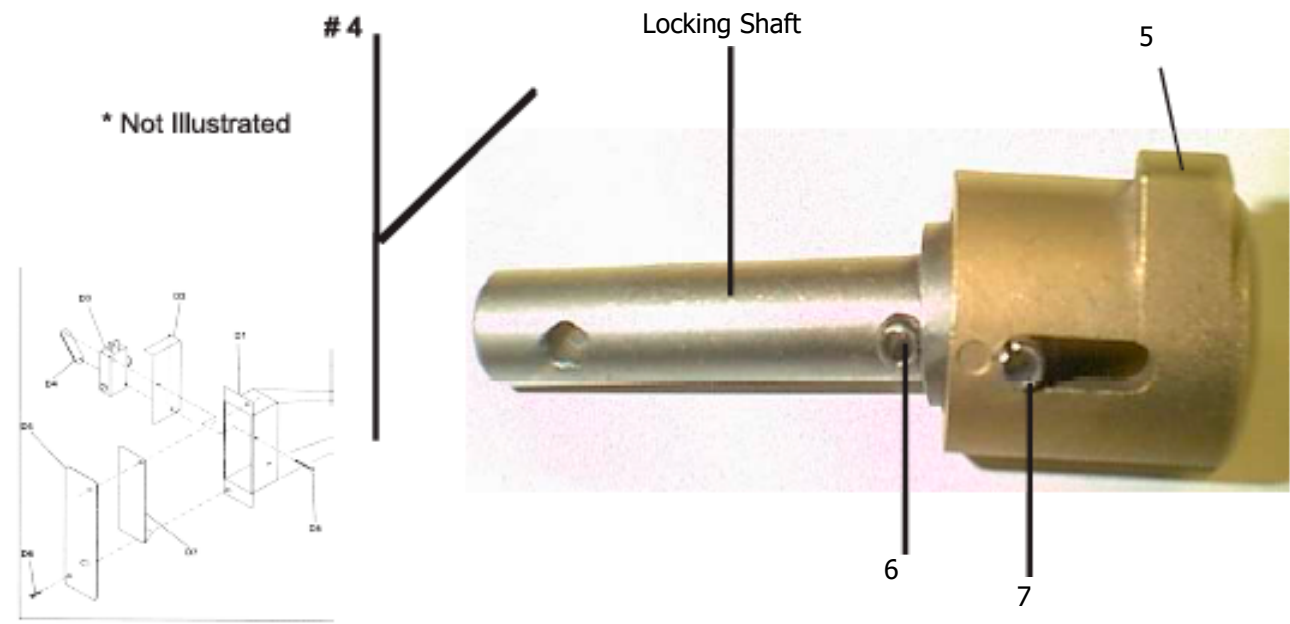
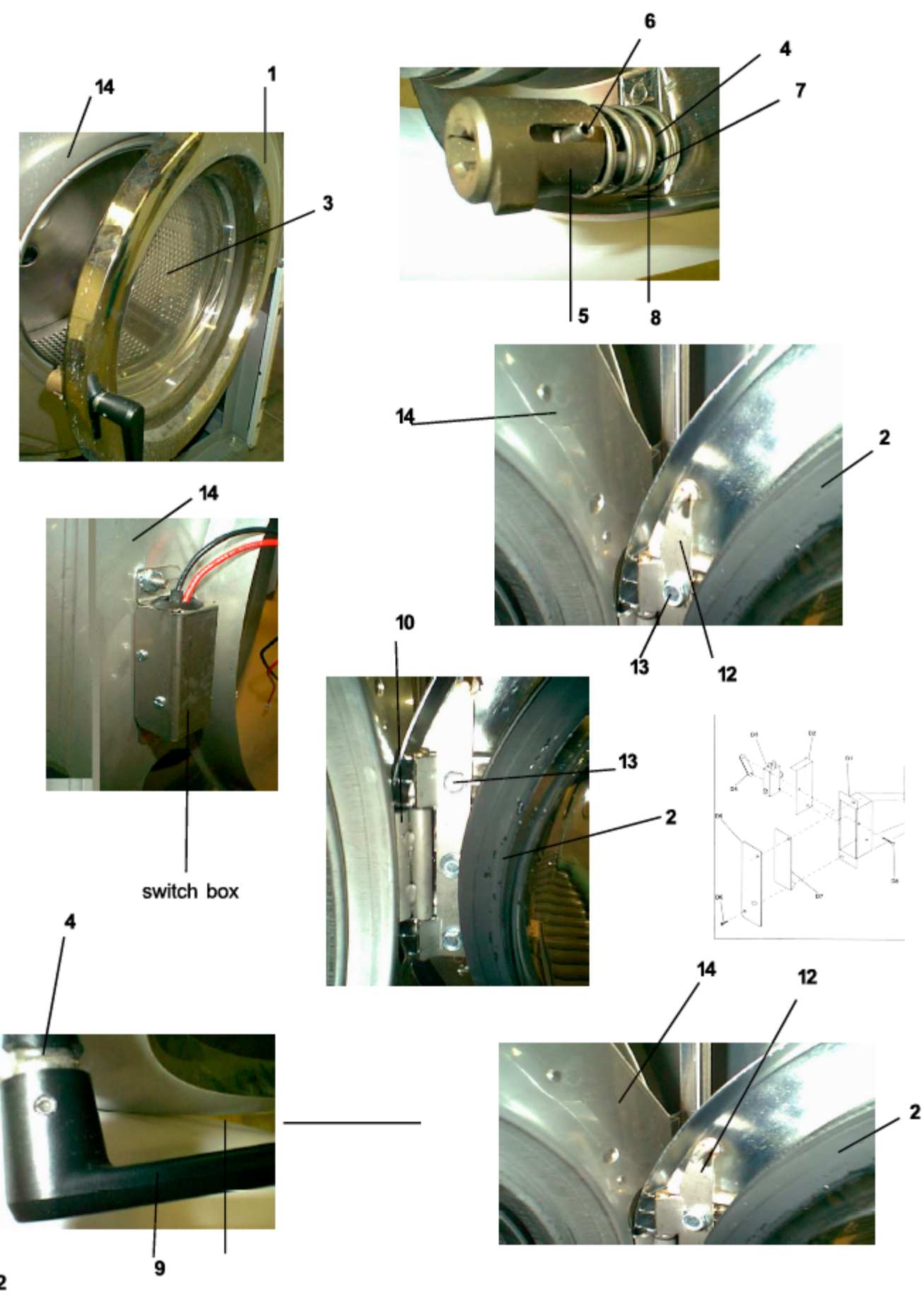

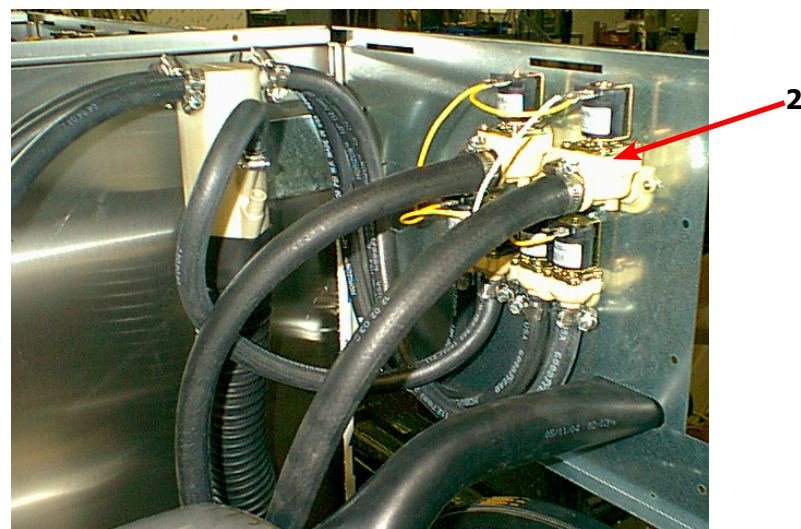
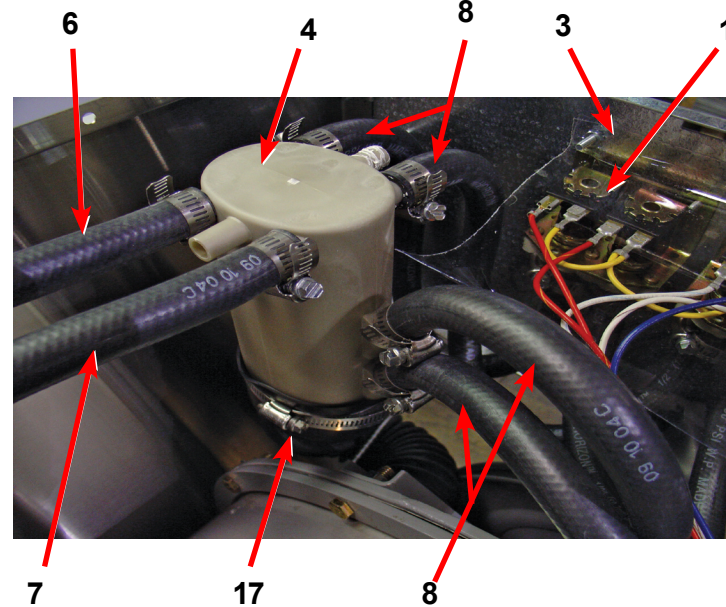
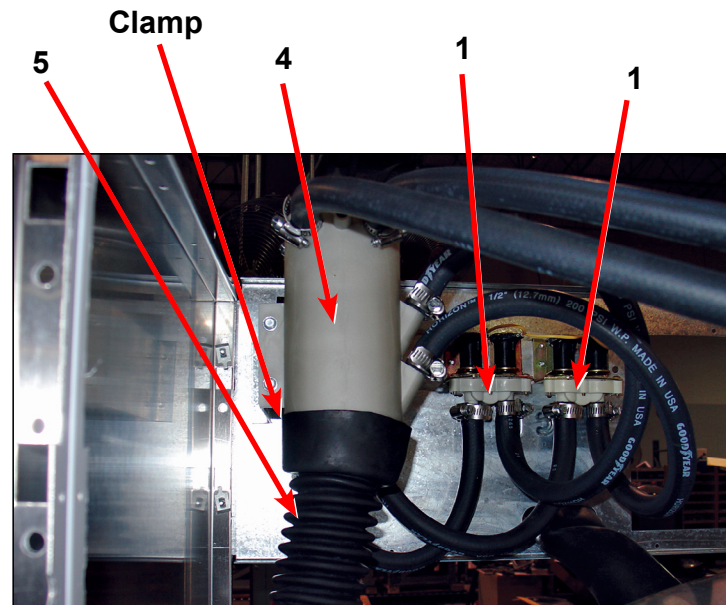

## Water Inlet Part # by Model

Key	Description	T 750	T-900	T-950	T-1200	T-1450	QTY
1	Valve, Water Inlet (dual outlet) (see Water Inlet Valve Break-down for individual parts)	9379-183-012	9379-183-012	9379-183-012	9379-183-012	9379-183-012	2
2	Valve Water Inlet (single outlet)			9379-194-001	9379-194-001	9379-194-001	2
*	Screw, Valve Mtg	9545-008-026	9545-008-026	9545-008-026	9545-008-026	9545-008-026	4
*	Screw, Valve M4x0.7x8mm			9495-064-001	9545-064-001	9545-064-001	8
3	Guard Water Valve Terminal		9208-049-001	9208-049-001	9208-049-001	9208-049-001	1
4	Vacuum Breaker	9610-001-001	9610-001-001	9610-001-001	9610-001-001	9610-001-001	1
*	Vacuum Breaker Cap (Red)		0935-135-002	0935-135-002	0935-135-002	0935-135-002	*
*	Bracket, Vacuum Breaker	9029-069-001	9029-069-001	9029-069-001	9029-069-001	9029-069-002	1
*	Screw	9545-008-026	9545-008-026	9545-008-026	9545-008-026	9545-008-026	4
*	Shield over Water Valves Plastic	9550-186-001	9550-186-001	9550-186-001	9550-186-001	9550-186-001	1
	Screw 10-32x3/4" for shield	9545-012-006	9545-012-006	9545-012-006	9545-012-006	9545-012-006	2
*	Nut #10-32	8640-413-004	8640-413-004	8640-413-004	8640-413-004	8640-413-004	2
5	Hose, Vacuum Breaker to Tub	9242-458-003	9242-458-003	9242-458-003	9242-458-003	9242-458-003	1
*	Clamp, Tub End;Vac Brkr	8654-117-014	8654-117-014	8654-117-014	8654-117-014	8654-117-014	1
6	Hose, Vac. Brkr. to Disp.	9242-453-009	9242-453-018	9242-453-018			1
7	Hose, Vac. Brkr. to Disp.	9242-453-006	9242-453-019	9242-453-019			1
9	Hose, Hot Valve to Tub		9242-453-020	9242-453-020	9242-466-002	9242-466-002	1
11	Hose, Cold Valve to Tub		9242-453-020	9242-453-020	9242-466-002	9242-466-002	1
12	Hose, Vac. Brkr. dispenser				9242-453-022	9242-453-023	3
13	Hose, (valve to vac. Brkr)	9242-453-020			9242-453-009	9242-453-009	4
*	Clamp, Hose-Spring (overflow from drain to tub back)	8654-117-018	8654-117-018	8654-117-018	8654-117-018	8654-117-018	2
	Hose, (valve to Tub Inlet)			9242-466-002	9242-466-002	9242-466-002	2
*	Clamp, Hose-Worm		8654-117-015	8654-117-015	8654-117-015	8654-117-015	1
*	Flow restrictor	9475-002-002	9475-002-002	9475-002-002	9475-002-002	9475-002-002	2
*	Flow restrictor		9475-002-002	9475-002-002	9475-002-003	9475-002-003	3
*	Circuit Breaker (optional)	5198-211-004	5198-211-004	5198-211-004			1
14	Fuseholder	9200-001-002	9200-001-002	9200-001-002	9200-001-002	9200-001-002	1
15	Fuse 1.5 amp	8636-018-001	8636-018-001	8636-018-001			1
15	Fuse 2.5 amp				8636-018-004	8636-018-004	1
17	Clamp, Vacuum Breaker End	8654-117-014	8654-117-014	8654-117-014	8654-117-014	8654-117-014	1
	Vacuum Breaker Cap		0935-135-002				2
	Hose Assembly Inlet	9990-027-013	9990-027-013				2

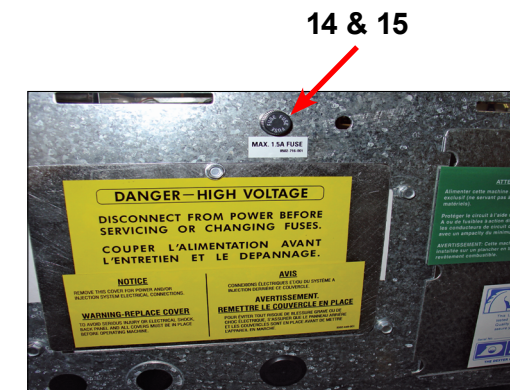

## Water Inlet Valve Breakdown Part # by Model

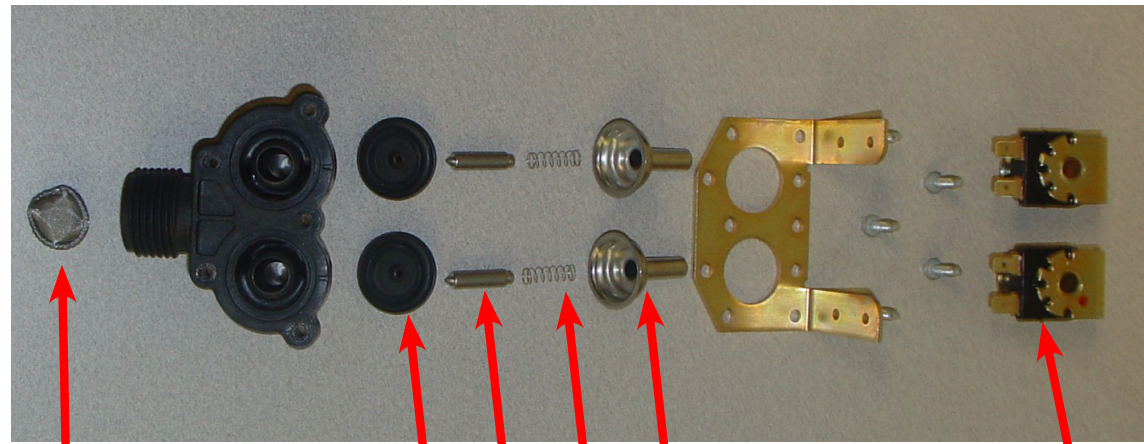

Key	Description	T-750	T-900	T-950	T-1200	T-1450	QTY
*	Valve, Water Inlet (includes 1 thru 6) - <b>Invensys</b>	9379-183-012	9379-183-012	9379-183-012	9379-183-012	9379-183-012	2
1	Screen, Inlet end of valve	9555-056-001	9555-056-001	9555-056-001	9555-056-001	9555-056-001	2
2	Coil Assy, 120 V Invensys	9089-017-001	9089-017-001	9089-017-001	9089-017-001	9089-017-001	2
3	Diaphragm Invensys (EPDM NSF)	9118-049-003	9118-049-003	9118-049-003	9118-049-003	9118-049-003	2
4	Guide, Solenoid Invensys	9211-021-002	9211-021-002	9211-021-002	9211-021-002	9211-021-002	2
5	Armature Invensys	9015-008-001	9015-008-001	9015-008-001	9015-008-001	9015-008-001	2
6	Spring, Armature Invensys	9534-298-001	9534-298-001	9534-298-001	9534-298-001	9534-298-001	2
*	Optional Diaphran (Viaton)	9118-049-002	9118-049-002	9118-049-002	9118-049-002	9118-049-002	2
*	Wiring Harness	9794-001-001			9794-001-001		1

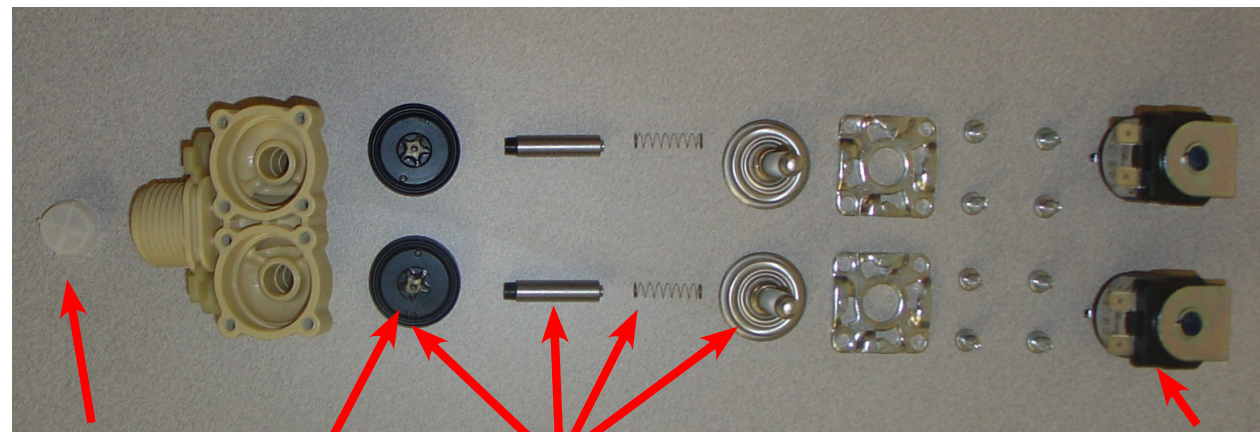

Optional Water Valve

Key	Description	T-750	T-900	T-950	T-1200	T-1450	QTY
*	Dual Coil Water Valve Mueller	9379-192-001	9379-192-001	9379-192-001	9379-192-001	9379-192-001	1
7	Valve Water Body Complete(no coil)	9379-192-002	9379-192-002	9379-192-002	9379-192-002	9379-192-002	1
8	Diaphragm Mueller	9118-054-001	9118-054-001	9118-054-001	9118-054-001	9118-054-001	2
9	Filter Mueller	9183-046-001	9183-046-001	9183-046-001	9183-046-001	9183-046-001	2
10	Coil Mueller	9089-051-001	9089-051-001	9089-051-001	9089-051-001	9089-051-001	2
11	Diaphragm Assembly Mueller Includes	9785-001-001	9785-001-001	9785-001-001	9785-001-001	9785-001-001	2

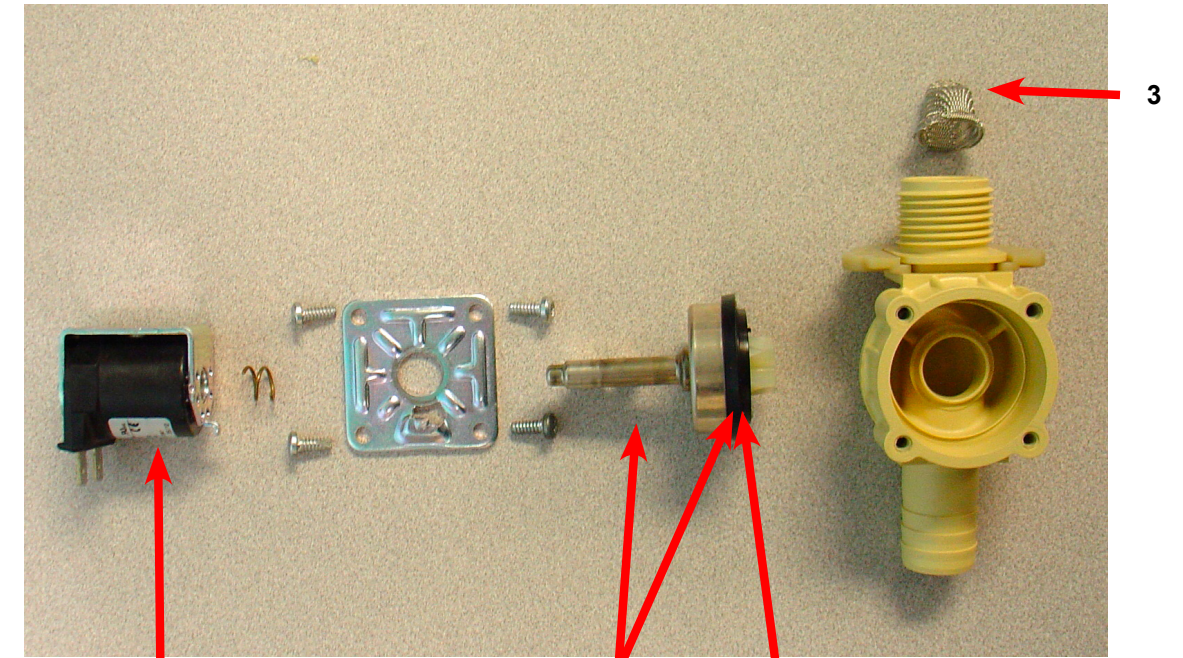

Key	Description	T-750	T-900	T-950	T-1200	T-1450	QTY
*	Single Coil Water Valve Mueller				9379-194-001	9379-194-001	1
1	Valve Water Body Complete (no coil)				9379-194-002	9379-194-002	1
2	Diaphragm Mueller				9118-055-001	9118-055-001	1
3	Filter Mueller				9183-046-001	9183-046-001	1
4	Coil Mueller				9089-051-001	9089-051-001	1
5	Diaphragm Assembly Mueller				9785-002-001	9785-002-001	1

## Notes

## Drain Valve Group Part # by Model

Key	Description	T-750	T-900	T-950	T-1200	T-1450	QTY
1	Valve, Drain (includes #2 thru #11)	9379-202-001	9379-202-001	9379-202-001	9379-202-001	9379-202-001	1
2	Body, Valve (w/ball)	9064-070-001	9064-070-001	9064-070-001	9064-070-001	9064-070-001	1
3	Motor & Gear Train (complete)	9914-137-011	9914-137-011	9914-137-011	9914-137-011	9914-137-011	1
4	Plate, Motor Mtg	9452-538-001	9452-538-001	9452-538-001	9452-538-001	9452-538-001	1
5	Screw	8639-994-001	8639-994-001	8639-994-001	8639-994-001	8639-994-001	3
6	Spring, Drive	9534-339-001	9534-339-001	9534-339-001	9534-339-001	9534-339-001	1
7	Screw	9545-054-001	9545-054-001	9545-054-001	9545-054-001	9545-054-001	2
8	Screw	9545-054-002	9545-054-002	9545-054-002	9545-054-002	9545-054-002	1
9	Seal, V Packer	9532-134-001	9532-134-001	9532-134-001	9532-134-001	9532-134-001	2
10	Washer	8641-584-001	8641-584-001	8641-584-001	8641-584-001	8641-584-001	1
11	Pin, Main Drive	9451-196-001	9451-196-001	9451-196-001	9451-196-001	9451-196-001	1
*	Plate (spacers needed for replacement motor mtg. plate)	9538-149-001	9451-196-001	9451-196-001	9538-149-001	9451-196-001	4
13	Stator and Coil Assembly	9089-036-004	9089-036-004	9089-036-004	9089-036-004	9089-036-004	1
*	Valve Drain before Serial # 482181	9379-187-001	9379-187-001	9379-187-001	9379-187-001	9379-187-001	1
14	Hose Tub to Drain Valve	9242-459-001	9242-456-001	9242-459-001	9242-459-001	9242-459-001	1
*	Replacement Seal Kit	9732-327-001	9732-327-001	9732-327-001	9732-327-001	9732-327-001	*

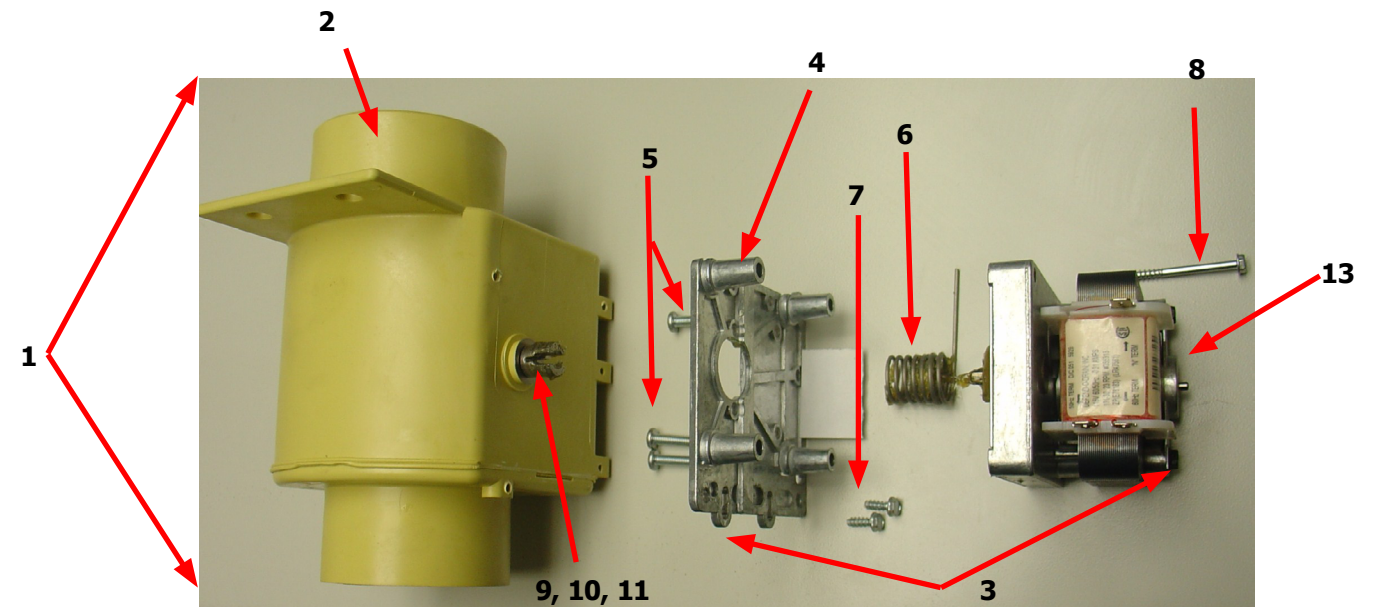

## Chassis and Drain Part # by Model

Key	Description	T750	T-900	T950	T-1200	T1450	QTY
1	Base Assy,Frame	9945-112-002	9945-128-002	9945-128-002	9945-125-002	9945-133-002	1
2	Outer Tub Assy Before Serial #535659	9930-148-001	9930-147-001		9930-149-001		1
2	Outer Tub Assy After Serial #535659		9930-156-001	9930-156-001		9930-155-001	1
*	Tub & Cylinder Assy Before Serial #535659	9869-025-002	9869-023-001		9869-022-002		1
*	Tub & Cylinder Assy After Serial #535659		9869-027-001	9869-027-001		9869-026-001	1
3	Tub Front Before Serial #535659	9974-011-001	9178-148-001	9178-148-001			1
3	Tub Front After Serial #535659		9974-011-002	9974-011-002	9974-011-002	9178-056-001	1
*	Gasket, Tub Front	9206-421-002	9206-421-002	9206-421-002	9206-421-002	9206-421-003	1
4	Ring Assy, Tub Mtg-Front Clamp	9950-055-001	9950-055-001	9950-055-001	9950-055-001	9950-061-001	1
5	Bolt, Top Front Ring 3/8"-16 x 3"	9545-029-009	9545-029-009	9545-029-009	9545-029-009	9545-029-009	1
6	Nut WCAD 3/8"-16	8640-415-001	8640-415-001	8640-415-001	8640-415-001	8640-415-001	1
7	Ring Assy,Clamp Tub Mtg. to Frame	9950-053-002	9950-053-002	9950-053-002	9950-053-002		1
8	Bolt, 1/2" -13 x 2" Ring	9545-017-013	9545-017-013	9545-017-013	9545-017-013		1
9	Bolt, 1/2" -13 x 2" Ring	8640-417-005	8640-417-005	8640-417-005	8640-417-005		1
10	Bolt, 1/2" -13 x 2" Rings to Base	9545-017-013	9545-017-013	9545-017-013	9545-017-013	9545-017-013	2
11	Nut, Wizloc 1/2" x 13	8640-417-005	8640-417-005	8640-417-005	8640-417-005	8640-417-005	2
12	Washer, Flat 1/2"	8641-581-026	8641-581-026	8641-581-026	8641-581-026	8641-581-026	2
13	Hose, Tub to Drain Valve	9242-456-001	9242-456-001	9242-456-001	9242-456-001	9242-459-001	1
14	Clamp, Hose (Tub to Drain Valve)	8654-117-014	8654-117-014	8654-117-014	8654-117-014	8654-117-014	2
15	Valve, Drain	9379-187-004	9379-187-004	9379-187-004	9379-187-004	9379-187-004	1
*	Screw, Valve to Base 1/4ABx3/4	9545-030-002	9545-030-002	9545-030-002	9545-030-002	9545-030-002	2
*	Washer, Flat 1/4	8641-581-017	8641-581-017	8641-581-017	8641-581-017	8641-581-017	2
16	Hose, Drain Valve to Tube	9242-457-001	9242-457-001	9242-457-001	9242-457-001	9242-457-001	1
*	Clamp, Hose (Drain Valve to Tube)	8654-117-014	8654-117-014	8654-117-014	8654-117-014	8654-117-014	2
17	Tube Assy, Drain	9915-124-002	9915-124-002	9915-124-002	9915-128-002	9915-129-002	1
18	Clamp, Hose (Tube to Frame Bracket)	8654-117-014	8654-117-014	8654-117-014	8654-117-014	8654-117-014	1
*	Bracket, Drain Tube	9029-067-002					1
*	Screw Tube (Bracket to Base 1/4Bx3/4)	9545-030-002	9545-030-002	9545-030-002	9545-030-002		4
19	Hose, Overflow Tub To Drain Tube	9942-449-003	9942-449-003	9942-449-003	9942-449-003	9942-449-005	1
*	Clamp, Hose	8654-117-018	8654-117-018	8654-117-018	8654-117-018	8654-117-018	1
*	Tube, Suds overflow	9242-463-004	9242-463-004	9242-463-004	9242-463-004	9242-463-006	1
*	Clamp, Hose	8654-117-008	8654-117-008	8654-117-008	8654-117-008	8654-117-008	2
20	Hose, Pressure switch	9242-175-007	9242-175-007	9242-175-007	9242-175-004	9242-175-004	1
	Clamp, Hose	8654-117-015	8654-117-015	8654-117-015	8654-117-015	8654-117-015	1

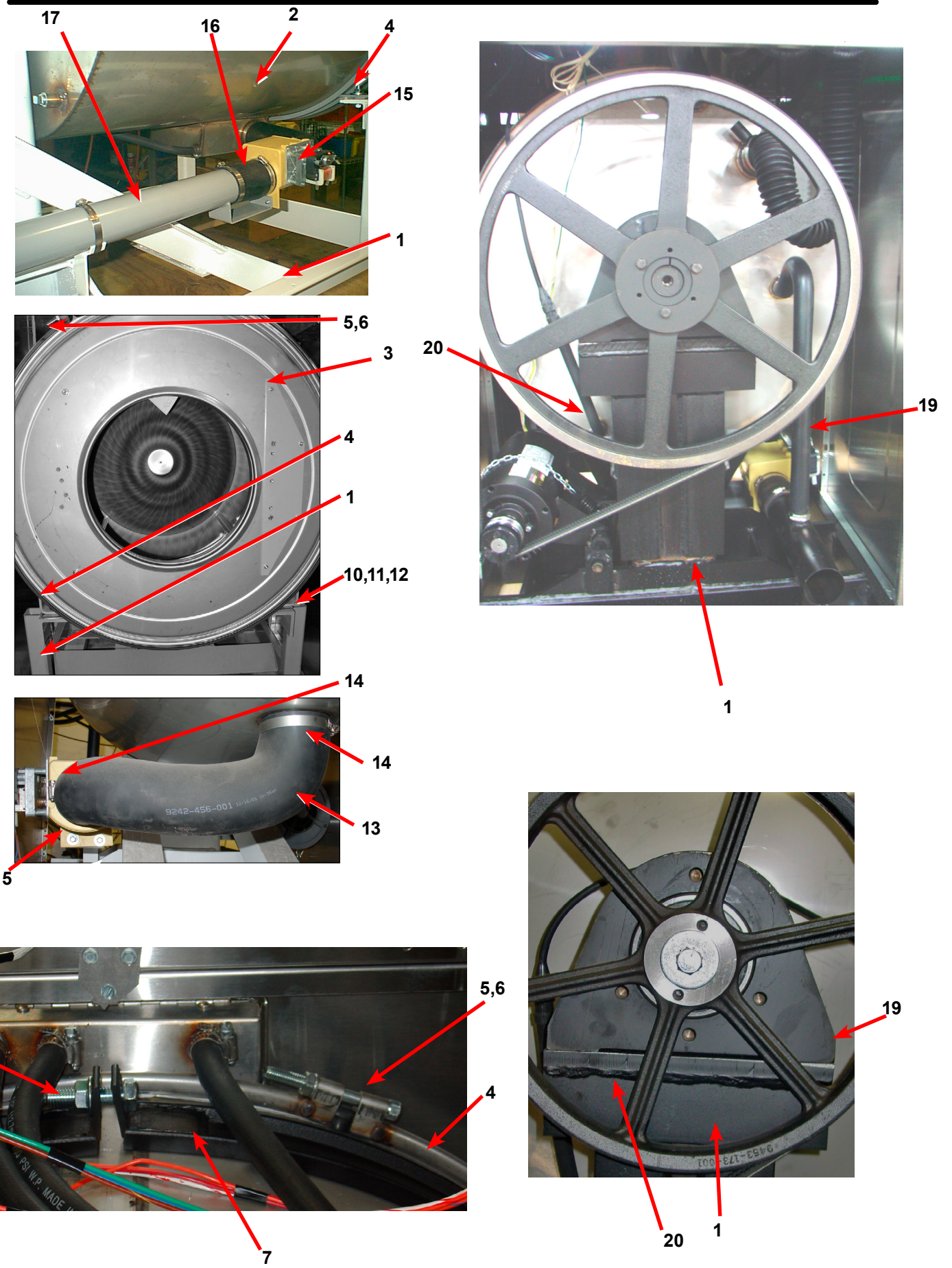

## Electrical Components - Top Compartment

Key	Description	T-750	T-900	T-950	T-1200	T-1450	QTY
1	Trough Assy,Controls 208-240 volt (all parts below #2-#43)	9857-159-002	9857-154-001		9857-160-001	9857-191-001	1
*	Trough only	9839-015-001	9839-015-001		9839-015-001	9839-017-001	1
*	Screw, Trough Sides	9545-008-026	9545-008-026	9545-008-026	9545-008-026	9545-008-026	4
*	Lockwasher Exttooth #10	8641-582-006	8641-582-006	8641-582-006	8641-582-006	8641-582-006	4
2	Angle Support Trough	9003-278-001	9003-271-001				1
3	Screw, Trough Bracket	9545-008-026	9545-008-026	9545-008-026	9545-008-026	9545-008-026	3
4	Transformer, Control (Secondary Voltage to 115 volts)	8711-004-001	8711-004-001	8711-004-001	8711-004-001	8711-004-001	1
*	Screw, Mtg #8Bx1/4"	9545-045-001	9545-045-001	9545-045-001	9545-045-001	9545-045-001	4
*	Lockwasher #10	8641-582-006	8641-582-006	8641-582-006	8641-582-006	8641-582-006	4
*	Screw GRN. #10-32x 1/2"	9545-008-027	9545-008-027	9545-008-027	9545-008-027	9545-008-027	1
*	Lockwasher #10	8641-582-006	8641-582-006	8641-582-006	8641-582-006	8641-582-006	1
*	Lug, Grounding	8652-130-037	8652-130-037	8652-130-037	8652-130-037	8652-130-037	1
5	PCB assembly Relay Main	9473-006-001	9473-006-001	9473-006-001	9473-006-001	9473-006-001	1
*	Spacer Plastic #8x3/8"	9538-157-011	9538-157-011	9538-157-011	9538-157-011	9538-157-011	6
*	Nuts Hexkeps #6-32	8640-411-003	8640-411-003	8640-411-003	8640-411-003	8640-411-003	6
6	Harness, P17 Drain/Therm/Sol	9627-796-002	9627-796-002	9627-796-002	9627-796-002	9627-796-002	1
7	Harness P19/Water Valve	9627-795-004	9627-795-002	9627-795-004	9627-795-004	9627-795-004	1
8	Harness P8/P16	9627-794-001	9627-794-001	9627-794-004	9627-794-004	9627-794-001	1
9	Harness P20/P21	9627-793-001	9627-793-001	9627-793-001	9627-793-001	9627-793-001	1
*	Bushing , Wire 7/8	9053-067-002	9053-067-002	9053-067-002	9053-067-002	9053-067-002	2
*	Standoff Twistlock	9527-002-002	9527-002-002	9527-002-002	9527-002-002	9527-002-002	3
10	Dynamic Braking Resistor	9483-004-003	9483-004-003		9483-004-003	9483-004-003	2
11	Screws #10-32x1/2" (pnhdcr)	9545-012-008	9545-012-008	9545-012-008	9545-012-008	9545-012-008	4
12	Nuts, #10-32 UNF 2B	8640-413-002	8640-413-002	8640-413-002	8640-413-002	8640-413-002	4
*	Screw #6-32x5/16"	9545-044-006	9545-044-006	9545-044-006	9545-044-006	9545-044-006	4
*	Nuts Hex #6-32	8640-411-003	8640-411-003	8640-411-003	8640-411-003	8640-411-003	4
11	Terminal Block Assy, POWER	9897-034-001	9897-034-001	9897-034-001	9897-034-001	9897-034-001	1
*	Screw, Mtg 8Bx3/8"	9545-045-007	9545-045-007	9545-045-007	9545-045-007	9545-045-007	2
12	Strip, Terminal Marker	9558-027-001	9558-027-001	9558-027-001	9558-027-001	9558-027-001	1
13	Switch, Pressure Before Serial #538202	9539-457-002	9539-457-002	9539-457-002	9539-457-002		1
13	Switch, Pressure After Serial #538202	9539-457-004	9539-457-004	9539-457-004	9539-457-004	9539-457-004	1
*	Screw, Mtg #10Bx1/2"	9545-008-026	9545-008-026	9545-008-026	9545-008-026	9545-008-026	2
*	Electronic Pressure Swtich Kit	9732-314-001	9732-314-001	9732-314-001	9732-314-001	9732-314-001	*
14	Harness P5/Pressure		9627-803-001	9627-803-001	9627-803-001	9627-899-001	1
15	Transformer, (Step Down) 120/2.3 VAC&24 VAC 50/60hz	8711-009-001	8711-009-001	8711-009-001	8711-009-001	8711-009-001	1
*	Screw, Transformer Mtg #8Bx1/4"	9545-045-001	9545-045-001	9545-045-001	9545-045-001	9545-045-001	4
*	Lockwasher #6 exttooth	8641-582-005	8641-582-005	8641-582-005	8641-582-005	8641-582-005	4
16	Fuseholder	9200-001-002	9200-001-002	9200-001-002	9200-001-002	9200-001-002	1
16	Fuse 1.5 amp	8636-018-001	8636-018-001	8636-018-001			1
16	Fuse 2.5 amp				8636-018-004	8636-018-004	1
17	Label Fuse 1.5 amp Rear	8502-716-001	8502-716-001	8502-716-001			1
17	Label Fuse 2.5 amp Rear				8502-716-002	8502-716-002	1
*	Bracket Terminal Mounting,		9029-076-001	9029-076-001			1
	Screw #10Bx1/2"	9545-008-026	9545-008-026	9545-008-026	9545-008-026	9545-008-026	4

## Electrical Components - Top Compartment

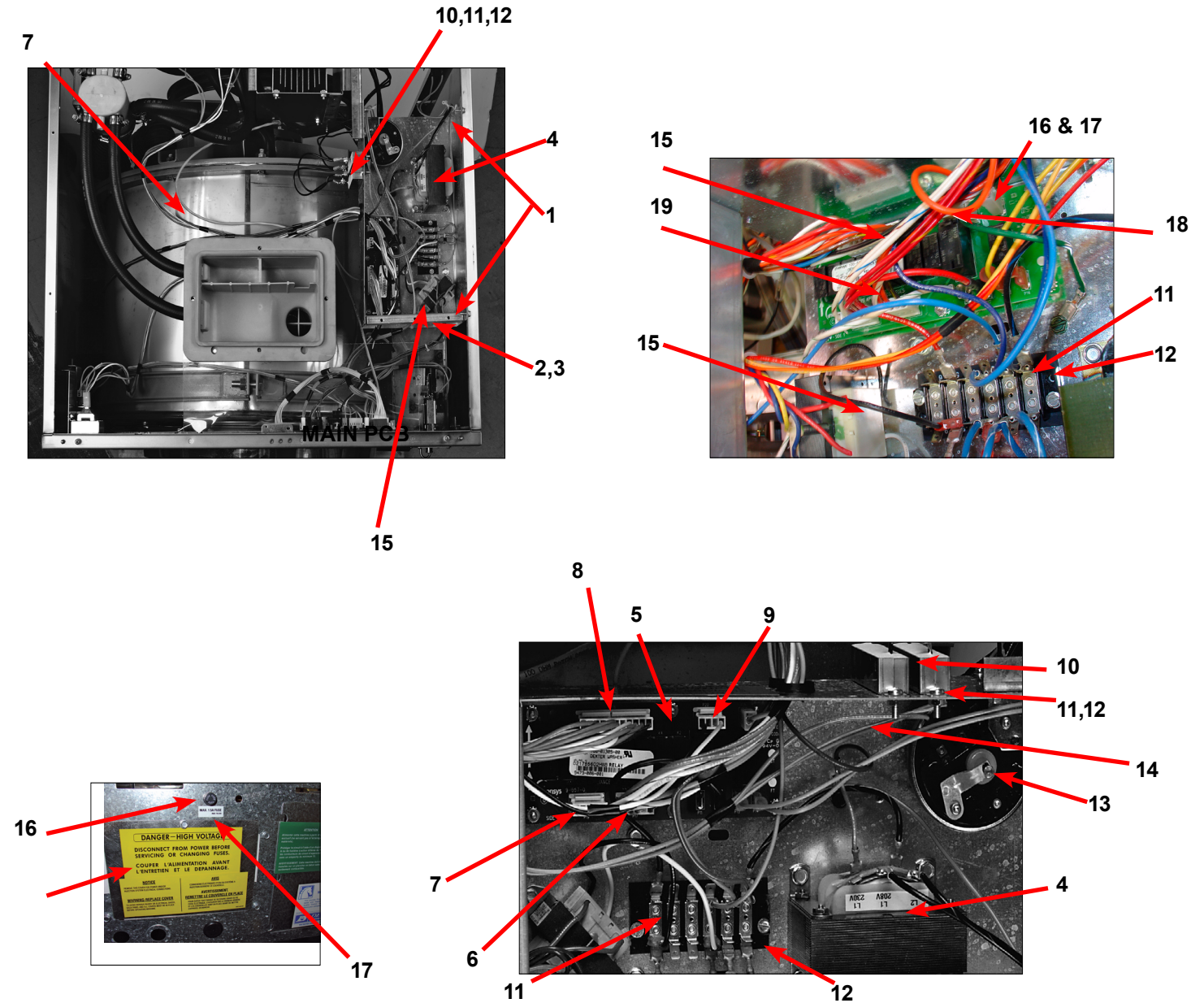

Key	Description	T-750	T-900	T-950	T-1200	T-1450	QTY
*	Terminal Lug, Solderless	8652-134-001	8652-134-001	8652-134-001	8652-134-001	8652-134-001	1
*	Terminal Block, Power	9897-033-001	9897-035-001	9897-035-001	9897-033-002	9897-035-001	1
*	Strip, Terminal Marker Power	9558-025-001	9558-025-001	9558-025-001	9558-025-001	9558-025-001	
*	Wiring Harness Power Terminal	9627-747-003	9627-747-002	9627-747-002	9627-747-002		1
18	Cover Electrical	9074-267-001	9074-267-001	9074-267-001	9074-267-007	9074-267-001	1
19	Label, Warning	8502-614-001	8502-614-001	8502-614-001	8502-614-001	8502-614-001	1
20	Label, Warning	8502-639-001	8502-639-001	8502-639-001	8502-639-001	8502-639-001	1
*	Screw 8B x 1/2	9545-008-026	9545-008-026	9545-008-026	9545-008-026	9545-008-026	2
*	Fuseholder	9200-001-002	9200-001-002	9200-001-002	9200-001-002	9200-001-002	1
*	Fuse 1.5 amp	8636-018-001	8636-018-001	8636-018-001			1
*	Fuse 2.5 amp				8636-018-004	8636-018-004	1

## Control Panel Part # by Model

Key	Description	T-750	T-900	T-950	T-1200	T-1450	QTY
1	Panel Control Assembly(panel only) Before Serial #530673	9989-500-001	9989-500-001		9989-500-001		1
1	Panel Control Assembly(panel only) After Serial #530673	9989-525-001	9989-525-001	9989-525-001	9989-525-001	9989-529-001	1
1a	Retainer, Coin Acceptor	9486-149-001	9486-149-001	9486-149-001	9486-149-001	9486-149-001	2
1b	Screw, Torx T-10 4Bx5/8ss	9545-053-002	9545-053-002	9545-053-002	9545-053-002	9545-053-002	4
*	Screw, Hxwshrhdunct #10Bx 1/2"	9545-008-026	9545-008-026	9545-008-026	9545-008-026	9545-008-026	4
2	Post Locator Top	9467-024-001	9467-024-001	9467-024-001	9467-024-001	9467-024-001	2
*	Nut Hexkeps #6-32	8640-411-003	8640-411-003	8640-411-003	8640-411-003	8640-412-005	2
3	Locator Panel	9355-001-001	9355-001-001	9355-001-001	9355-001-001	9355-001-001	2
*	Screw FillHDCR 10Bx1/2" Guide	9545-008-025	9545-008-025	9545-008-025	9545-008-025	9545-008-023	2
*	Spacer Pushbutton (Micro)	9538-178-001	9538-178-001	9538-178-001	9538-178-001	9538-178-001	1
*	Retainer Pushbutton (Micro)	9486-150-001	9486-150-001	9486-150-001	9486-150-001	9486-150-001	1
*	Nut Hexelasticstop #4-40	8640-424-002	8640-424-002	8640-424-002	8640-424-002	8640-424-002	2
10	Pushbutton Control (coin), Blue	9035-062-001	9035-062-001	9035-062-001	9035-062-001	9035-062-001	1
10	Pushbutton Control (coin), Black	9035-062-002	9035-062-002	9035-062-002	9035-062-002	9035-062-002	1
7	PCB assembly Control /Display STOP	9473-009-005	9473-009-005	9473-009-005	9473-009-005	9473-009-005	1
11	Spacer Plastic #6x9/16	9538-157-018	9538-157-018	9538-157-018	9538-157-018	9538-157-018	5
11	Nut Elasticstop #6-32	8640-411-002	8640-411-002	8640-411-002	8640-411-002	8640-411-002	5
12	Harness LEDPCB	9627-797-001	9627-797-001	9627-797-001	9627-797-001	9627-797-001	1
8	Harness Doorlock, Switches	9627-791-004	9627-791-005	9627-791-005	9627-791-005	9627-791-006	1
16	PCB assembly Mode lights	9473-005-001	9473-005-001	9473-005-001	9473-005-001	9473-005-001	1
*	Spacer Plastic #6x9/16	9538-157-018	9538-157-018	9538-157-018	9538-157-018	9538-157-018	2
*	Nut Hexkeps #6-32	8640-411-003	8640-411-003	8640-411-003	8640-411-003	8640-411-003	2
19	Light, LED,ADD BLEACH Assembly	9794-001-001	9794-001-001	9794-001-001	9794-001-001	9794-001-001	1
*	Spacer Plastic #6x9/16	9538-157-018	9538-157-018	9538-157-018	9538-157-018	9538-157-018	2
*	Nut Hexeps #6-32	8640-411-003	8640-411-003	8640-411-003	8640-411-003	8640-411-003	2
9	Nameplate,Control Panel (one piece) Blue Before Serial #535659	9412-162-001	9412-141-001		9412-142-001		1
	Nameplate,Control Panel (one piece) Black Before Serial #535659		9412-165-001		9412-173-001		1
	Nameplate,Control Panel (one piece) Blue After Serial #535659	9412-162-001	9412-198-001	9412-191-001		9412-193-001	1
	Nameplate,Control Panel (one piece) Black After Serial #535659	9412-172-001	9412-199-001	9412-192-001		9412-194-001	1
22	Switch Assembly Emergency Stop (includes wire harness)	9732-223-001	9732-223-001	9732-223-001	9732-223-001	9732-223-001	1
*	Spacer Plastic #8x5/16 E-Stop	9538-157-020	9538-157-020	9538-157-020	9538-157-020	9538-157-020	2
*	Nut HexKep #8-32 E-Stop	8640-412-005	8640-412-005	8640-412-005	8640-412-005	8640-412-005	2
26	Battery	8612-001-001	8612-001-001	8612-001-001	8612-001-001	8612-001-001	1
*	Plastic Shield over main PCB	9550-184-001	9550-184-001	9550-184-001	9550-184-001	9550-184-001	1
27	Plate to mount e-stop button	9452-725-001	9452-725-001	9452-725-001	9452-725-001	9452-725-001	1
*	Bracket Retainer, Front Panel	9029-191-001	9029-191-001	9029-191-001	9021-191-001		1
*	Bracket Retainer, Front Panel					9029-191-001	2
*	Screw-#10Bx1/2	9545-008-026	9545-008-026	9545-008-026	9545-008-026		3
*	Screw-#10Bx1/2					9545-008-026	6

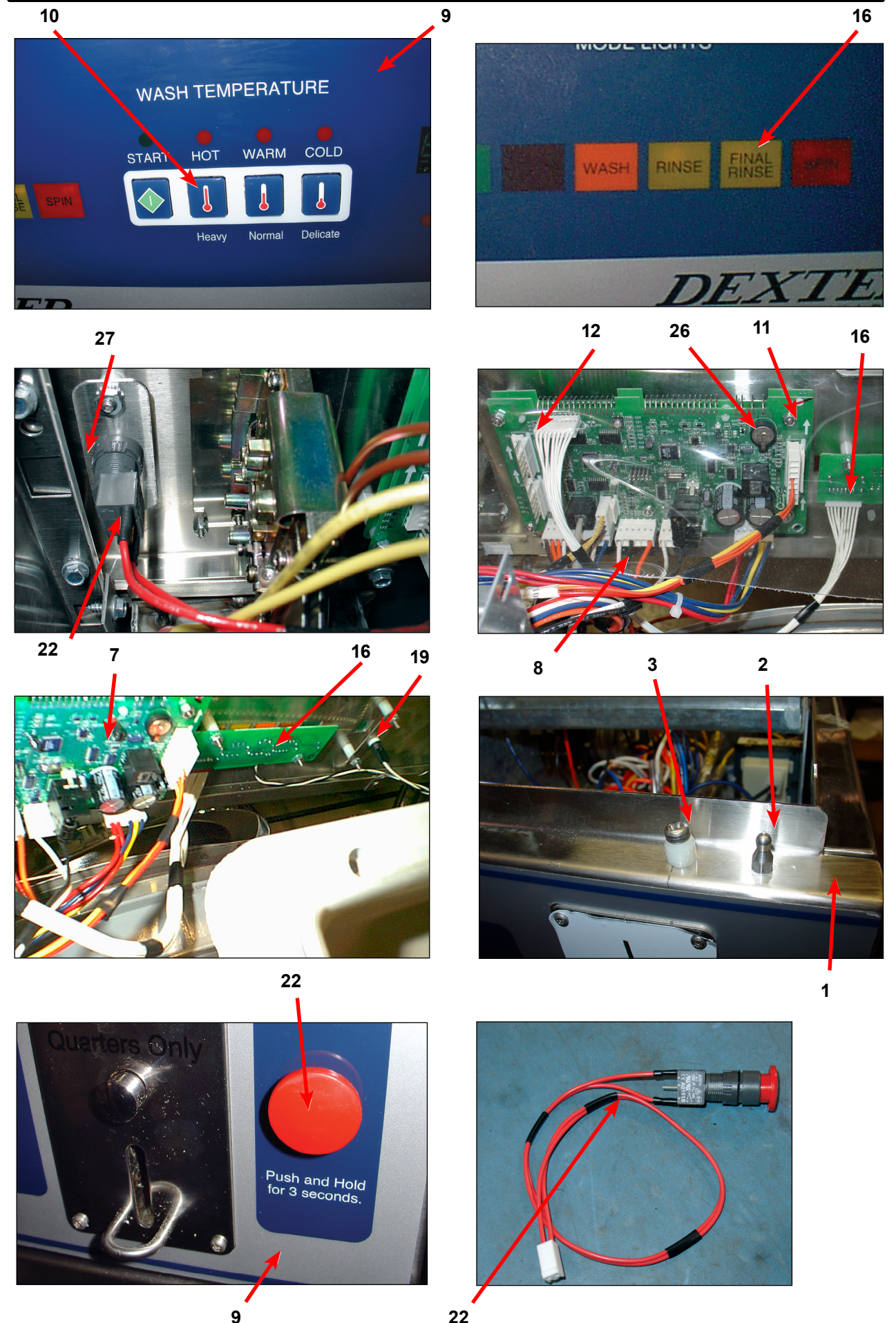



## Labels and Diagrams All WCAD Models

Key	Description	T750	T-900	T950	T-1200	T1450	QTY
*	Booklet Owners	8514-157-001	8514-099-001	8514-183-001	8514-159-001		1
*	Wiring Diagram, Coin	9506-358-001	9506-127-001		9506-129-001	9506-488-001	1
*	Wiring Diagram Easy Card (120 V)						1
*	Wiring Diagram (Easy Card)		9506-113-001	9506-486-001	9506-115-001		1
*	Transient Voltage Surge Suppressor Infomational		8507-330-001		8507-330-001	8507-330-001	1
*	Instructions Spin Direction		8507-275-001		8507-275-001	8507-275-001	1
*	Wiring Schematic, Coin (120 V)						1
*	Wiring Schematic, Easy Card (120 V)						1
*	Wiring Schematic, Coin	9506-357-001	9506-126-001	9506-486-001	9506-128-001	9506-488-001	1
*	Wiring Schematic, Easy Card		9506-112-001		9506-114-001		1
*	Label High Voltage Warning	8502-614-004	8502-614-004	8502-614-004	8502-614-004	8502-614-004	1
*	Label Fusing & Installation	8502-619-003	8502-619-003	8502-619-003	8502-619-003	8502-619-008	1
*	Label Quality	8511-001-002	8511-001-002	8511-001-002	8511-001-002	8511-001-002	1
1	Label Warning Risk of Injury (Blue)	8502-722-002	8502-722-002	8502-722-002	8502-722-002	8502-722-002	1
1	Label Warning Risk of Injury (Black)	8502-741-001	8502-741-001	8502-741-001	8502-741-001	8502-741-001	
2	Label Warning Door Opening (Blue)	8502-723-001	8502-723-001	8502-723-001	8502-723-001	8502-723-001	1
2	Label Warning Door Opening (Black)	8502-742-001	8502-742-001	8502-742-001	8502-742-001	8502-742-001	
3	Label Dispenser (Blue)		8502-687-001	8502-687-001	8502-687-001	8502-687-001	1
3	Label Dispenser (Black)		8502-745-001	8502-745-001	8502-745-001	8502-745-001	1



Door Label

2



Risk of Injury Label

Top Dispenser Label T-1200

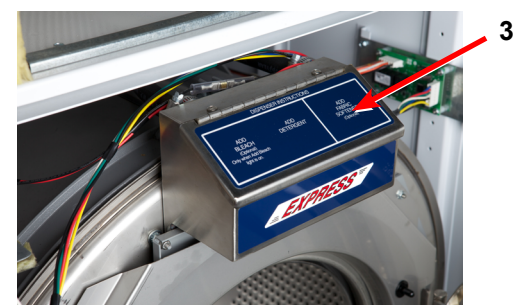

3

## Section 9:

### Coin Handling

### Parts:

Wiring Diagrams  
& Schematics &  
maintenance Procedures

# Coin Handling Group Part # Micro Switch

Key	Description	T-750	T-900	T-950	T-1200	T-1450	QTY
1	Vault, Assy Grey	9942-037-001	9942-037-001	9942-037-001	9942-037-001		1
1	Vault, Assy. Black	9942-037-005	9942-037-005	9942-037-005	9942-037-005		1
*	Screw, 10Bx 1/2" Vault Mtg	9545-008-026	9545-008-026	9545-008-026	9545-008-026		2
*	Screw, 10AB x 1/2" Vault Mtg	9545-008-031	9545-008-031	9545-008-031	9545-008-031		2
2	Coin Chute Assy.	9119-031-001	9119-031-001	9119-031-001	9119-028-001	9119-028-001	1
*	Screw, Coin Vault Chute Mtg	9545-008-001	9545-008-001	9545-008-001	9545-008-001	9545-008-001	1
3	Coin Acceptor chute without penny rejector for mechanical drop (standard)	9119-025-002	9119-025-002	9119-025-002	9119-025-002		1
*	Screw, Acceptor Mtg	9545-020-004	9545-020-004	9545-020-004	9545-020-004	9545-020-004	4
*	Nut	8640-424-002	8640-424-002	8640-424-002	8640-424-002	8640-424-002	4
4	Switch, Coin (fits single coin mechanical drop)	9732-126-001	9732-126-001	9732-126-001	9732-126-001		1
5	Coin Acceptor chute with penny rejector for mechanical drop (optional)	9119-025-001	9119-025-001	9119-025-001	9119-025-001		
6	Button Coin Return Retainer	9486-133-001	9486-133-001	9486-133-001	9486-133-001		1
7	Coin Acceptor Mechanical Complete	9021-001-010	9021-001-010	9021-001-010	9021-001-010		1
8	Soloid, Coin Blocking (V-Series)						1
*	Screw, Highth Bar/Chute 3mm	9545-039-002	9545-039-002	9545-039-002	9545-039-002		2
9	Vertical Chute Mounting Screw	9545-025-020	9545-025-020	9545-025-020	9545-025-020		2
*	Harness, Coin Switch V& A Series	9627-792-001	9627-792-001	9627-792-001	9627-792-001		1

**NOTE: COIN BOX AND HARDWARE KIT AND COIN BOX LOCK NOT INCLUDED WITH MACHINE.**

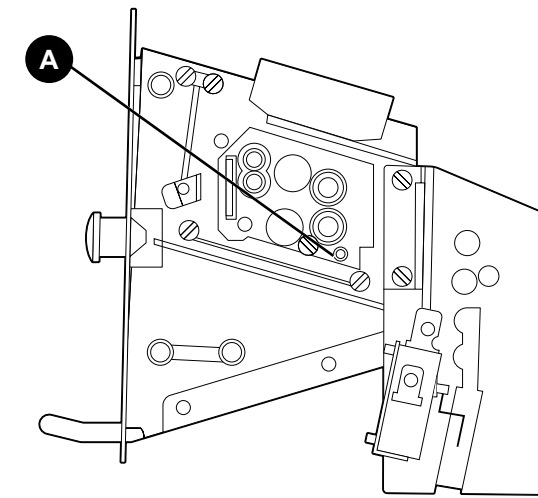
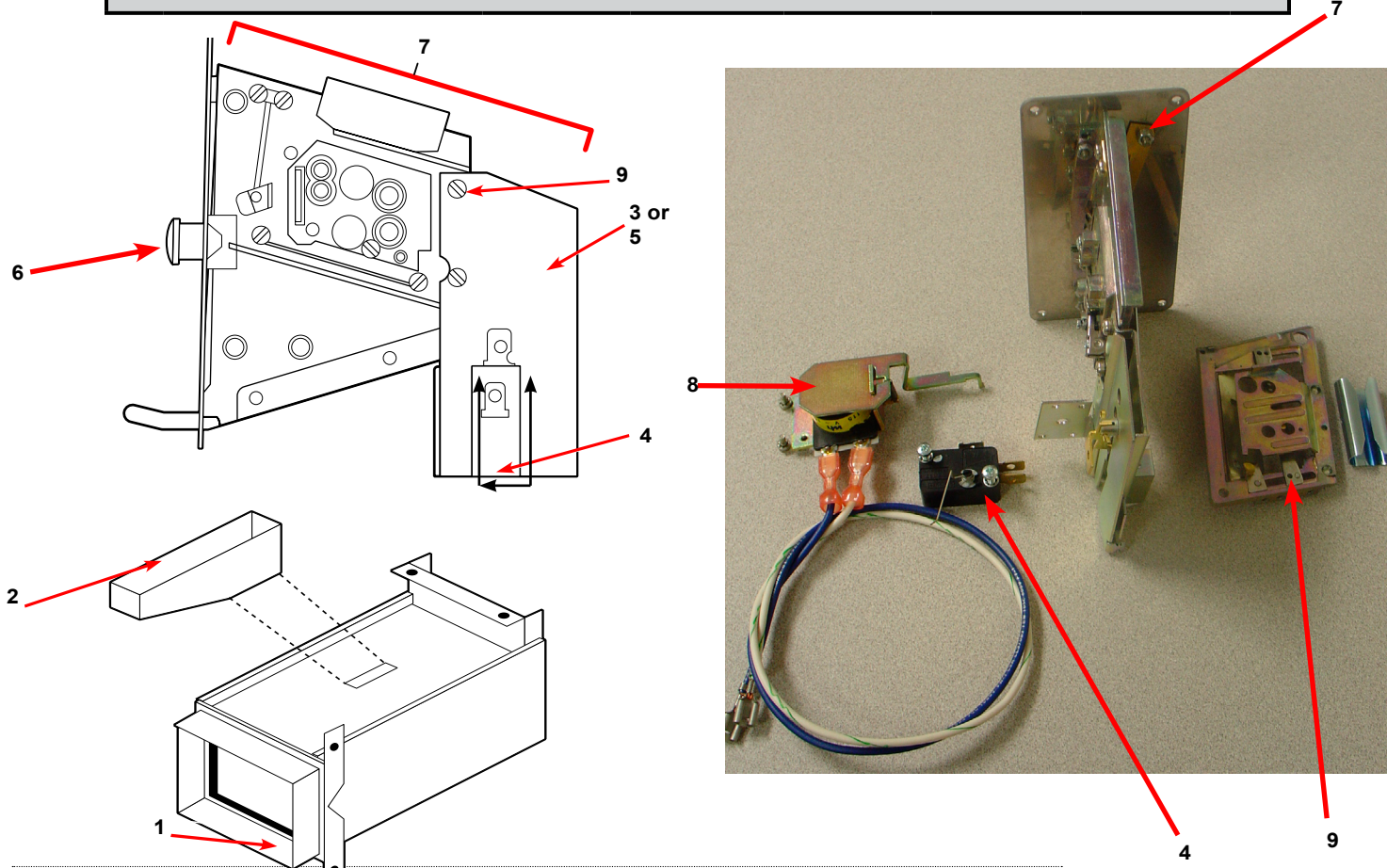

Left View Coin Drop Acceptor

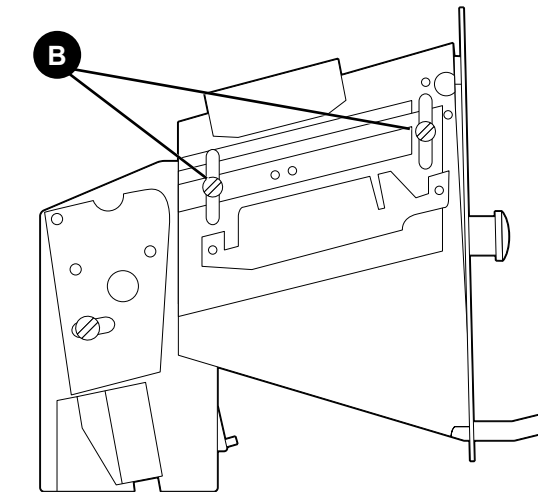

Right View Coin Drop Acceptor

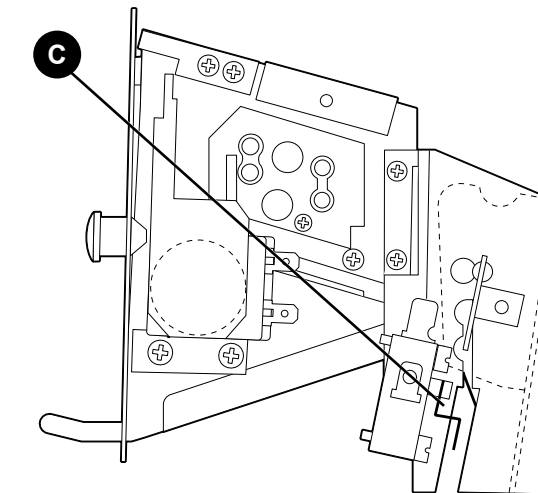

## Mechanical Acceptor

### Standard Coin Drop Acceptor

The drop style coin acceptor contains a coin switch that is actuated by each good coin that is accepted.

### Removal

The coin acceptor is removed by loosening the two Torx T-10 machine screws on the right side and by removing completely the two Torx T-10 machine screws on the left side (#T-10 Torx driver, Dexter Pt. No. 8545-051-003). There are locking nuts on the back side that will have to be held. Needle-nose pliers work well for this. Sliding the acceptor to the left will remove it from the slots in the front panel. This gives access to the coin switch and acceptor for adjustments.

### Coin Thickness Adjustment (see diagram)

On the right side of the acceptor there is a coin thickness adjusting screw "A" with a locking nut. To allow for different thickness coins the screw can be turned in to accept thicker coins and turned out to reject thicker coins. Start with a quarter of a turn on this screw and be sure to retighten the lock nut after adjustment.

### Coin Height Adjustment (see diagram)

On the left side of the acceptor is a coin height adjusting bar "B". This bar is adjusted by loosening the two mounting screws and moving both ends of the bar up or down equal amounts. The bar should be raised as high as possible while still accepting the correct coins. If it is raised up too high, the good coins will be rejected.

### Coin Switch Adjustment (see diagram)

The normally open coin switch "C" should click (close) soon after the coin hits the operator wire. However, there must be enough travel to allow the switch to reset (open) once the coin has passed. Adjustment should be made by bending the wire very close to its attachment point.

## Optical Coin Acceptor

Starting after serial# 515483

Key-	Description	T-750	T-900	T-950	T-1200	T-1450	
1	Optical Coin Acceptor	9021-092-002	9021-092-002	9021-092-002	9021-092-002	9021-092-002	1
2	Replacement Optical Sensor	9801-099-001	9801-099-001	9801-099-001	9801-099-001	9801-099-001	1
*	Screw, Highth Bar, 3mm	9545-039-002	9545-039-002	9545-039-002	9545-039-002	9545-039-002	2

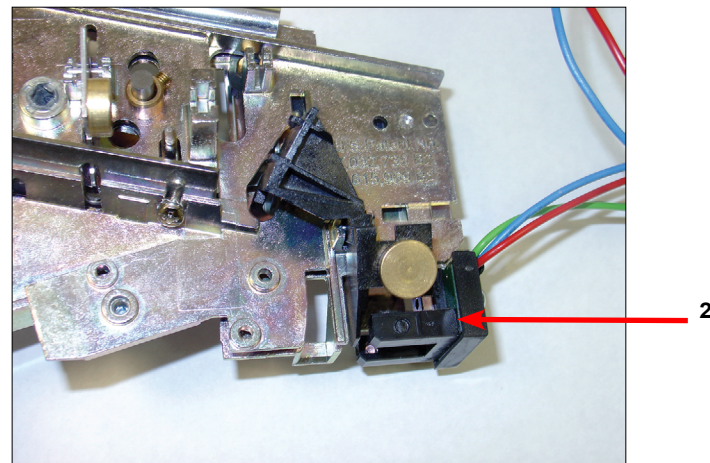
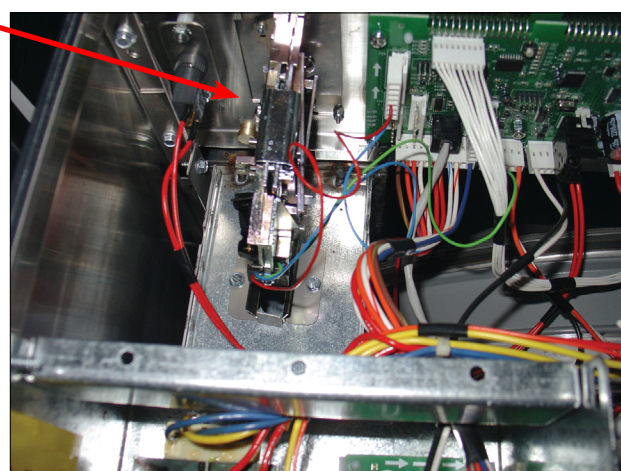
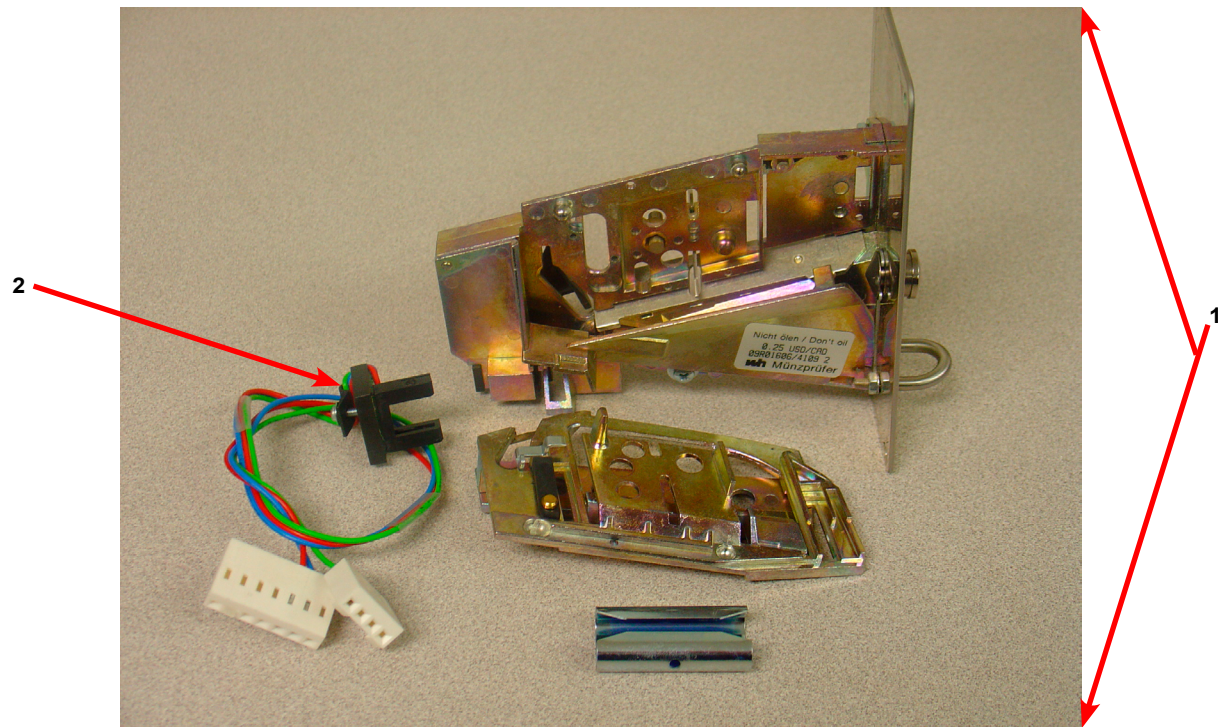

## Imonex Optical Coin Acceptor

Starting after serial# 515483

Key-	Description	T-750	T-900	T-950	T-1200	T-1450	
1	Optical Coin Acceptor					9021-034-001	1

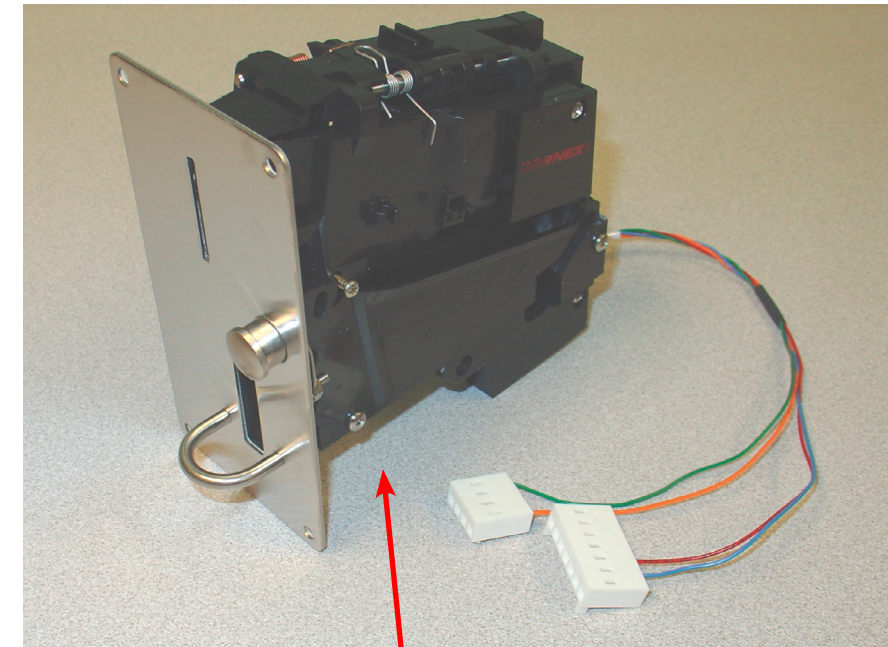



# Electronic Acceptor Coin Drop

## Setting the electronic coin acceptor switches

Some washer models come equipped with an electronic coin acceptor. Follow the instructions below for setting the switches for the desired country and currencies.

1. The electronic coin acceptor has switch settings depending on the coins and country. See the table below for available values of the left and right coin inputs for the available countries.

**WARNING:** turn power off before and leave power off when changing the switches of the electronic coin acceptor.

2. Turn power back on and test coins to ensure proper operation.

Acceptor P/N	Country	Left Coin	Right Coin	SWs 1-8	SWs 9-16
9021-028-001	Canada	25¢		↓↑↑↑↑↑↓	↓↑↑↑↑↑↓
	Canada		\$1	↑↑↓↑↑↑↓	↓↑↑↑↑↑↓
	Canada		\$2	↑↑↑↑↓↑↓	↓↑↑↑↑↑↓
				↓↑↑↑↑↑↓	↑↓↑↑↑↑↓
				↑↑↓↑↑↑↓	↑↓↑↑↑↑↓
				↓↑↑↑↑↑↓	↑↑↓↑↑↑↓
				↑↑↓↑↑↑↓	↑↑↓↑↑↑↓
				↓↑↑↑↑↑↓	↑↑↓↑↑↑↓
			Greenwald 118-1 Token	↑↑↑↑↑↑↓	↑↑↑↑↓↑↓
			Greenwald 118-5 Token	↑↑↑↑↑↑↓	↑↑↑↑↓↑↓
		U.S.A.	25¢	↓↑↑↑↑↑↓	↑↑↑↑↑↑↓
	U.S.A.		\$1	↑↑↓↑↑↑↓	↑↑↑↑↑↑↓
9021-011-001	Australia	10¢		↓↑↑↑↑↑↓	↑↓↑↑↑↑↓
	Australia	20¢		↑↑↓↑↑↑↓	↑↓↑↑↑↑↓
	Australia		\$1	↑↑↑↑↓↑↓	↑↑↓↑↑↑↓
	Australia		\$2	↑↑↑↑↑↑↓	↓↑↓↑↑↑↓
	New Zealand	10¢		↓↑↑↑↑↑↓	↑↓↑↑↑↑↓
	New Zealand	20¢		↑↑↓↑↑↑↓	↑↓↑↑↑↑↓
	New Zealand		\$1	↑↑↑↑↓↑↓	↑↑↑↓↑↑↓
	New Zealand		\$2	↑↑↑↑↑↑↓	↓↑↓↑↑↑↓
	Hong Kong	\$5		↓↑↑↑↑↑↓	↑↑↑↑↓↑↓
	Hong Kong		\$10	↑↑↑↑↓↑↓	↑↑↑↓↑↑↓
			Greenwald 118-1 Token	↑↑↑↑↑↑↓	↑↑↑↑↓↑↓
		Greenwald 118-5 Token	↑↑↑↑↑↑↓	↑↑↑↑↓↑↓	

**NOTE:** Coins and tokens in the left coin column will result in one pulse to the left coin input.

**NOTE:** The \$1, 500¥, 50NT, and \$10 coins in the right coin column will result in one pulse to the right coin input, while the \$2 coins will result in two pulses to the right coin input.

Note: Acceptance of multiple coins per country and multiple tokens is allowed. Only the down/off setting for each coin and token is required to accept that coin or token.

# Maintenance Instructions

## Electronic Acceptor

### 1. Instructions to open the flap of the coin selector

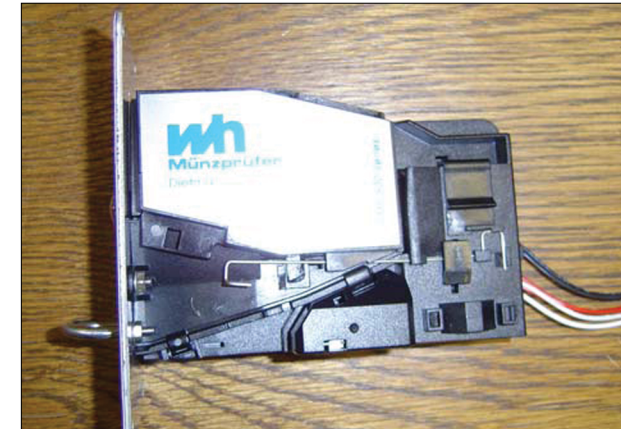

Original situation



Move spring downwards to free the catch.

**NOTE:**

- Do not lift the spring
- Do not over bend the spring in any direction.



Open the flap of the coin selector.

### 2. Assembly instructions to change a spring

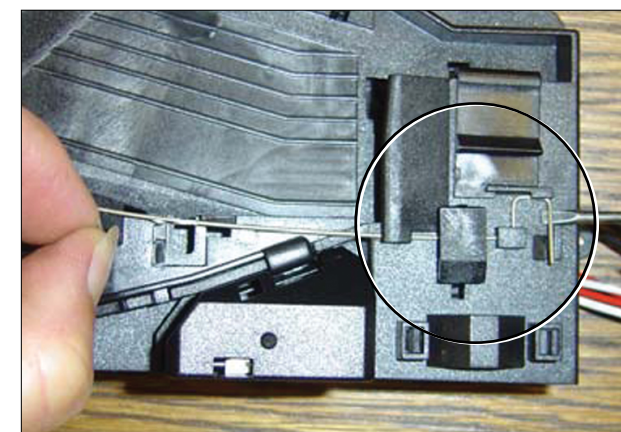

Lift the right end of the spring by means of a screw driver.

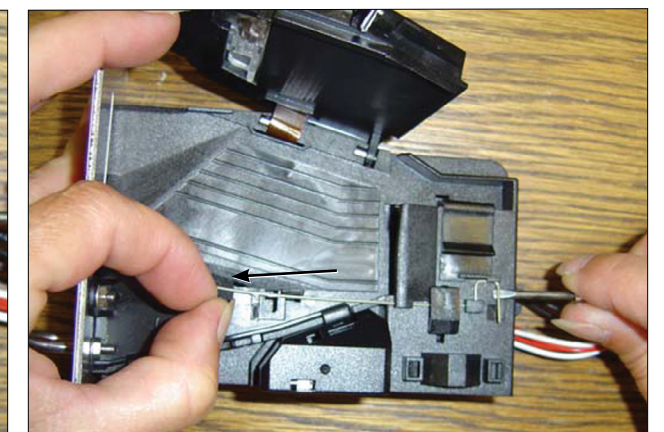

Pull the spring approximately 3 mm to the left.

## Electronic Acceptor

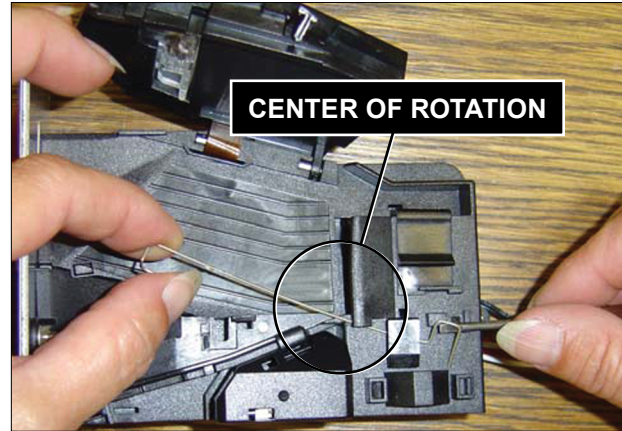

Rotate the spring clockwise for about 40 to 60 degrees until it becomes free of the protrusion.

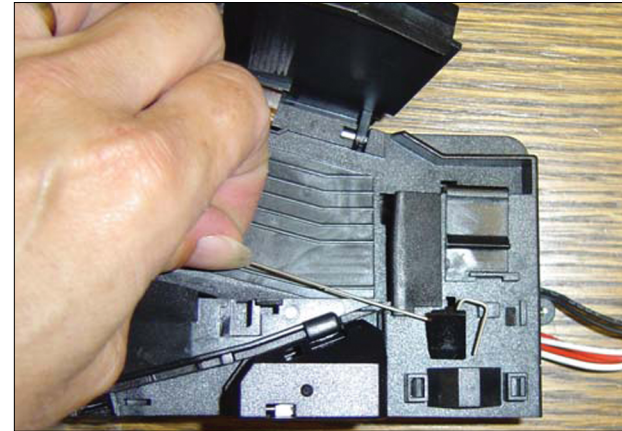

Lift off the spring with the attached plastic part.

### 3. Assembly of a new spring

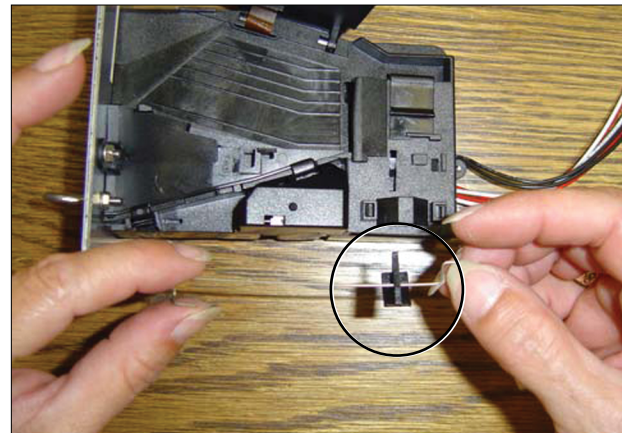

Attach the plastic part to the new spring.

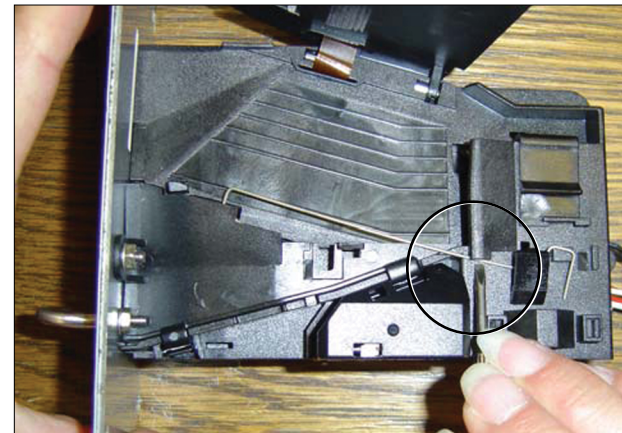

Place the plastic part in its position (slot).

Push the spring below the protrusion by means of a small screw driver.

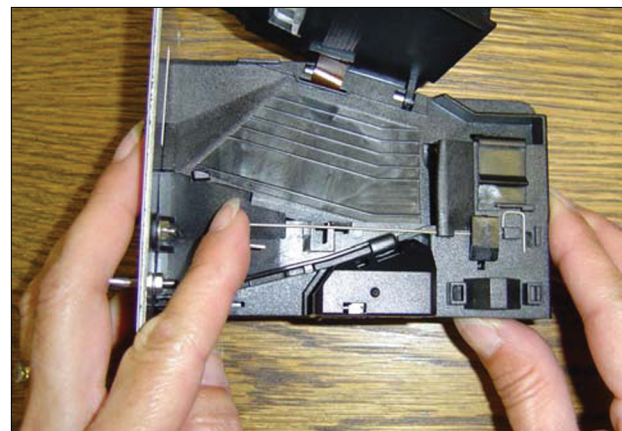

Push the spring lateral to the right until its snaps into its proper position.

## Electronic Acceptor

### 4. Close the coin selector

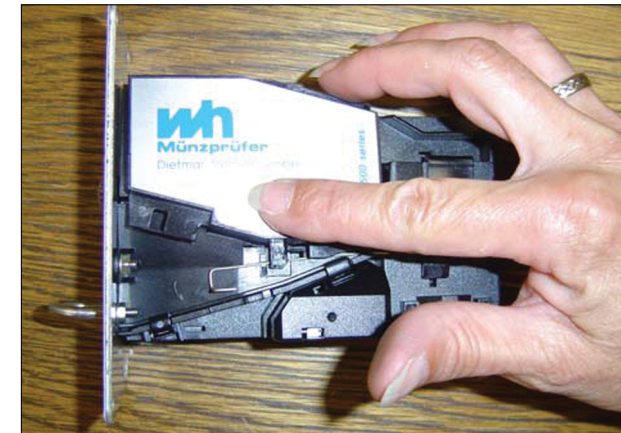

To shut the coin selector follow pictures 1 to 3 in reverse order.

### 5. Cleaning the electronic coin selector

The EMP 500 v4 is an extraordinarily robust coin selector and operates relatively maintenance free. However, it should be cleaned at regular intervals (minimum once a year) especially if it is operating in an environment with high levels of dust, smoke or nicotine. The cleaning intervals are of course dependent on the level of air borne contaminants.



Clean the coin path with a soft brush and wipe the exposed surfaces. Use an alcohol moistened cloth.



If you find solid residues stuck to the coin rail (partina) remove it with an alcohol moistened cloth.



Optical sensors may be cleaned with a soft brush or very carefully with an air spray duster.

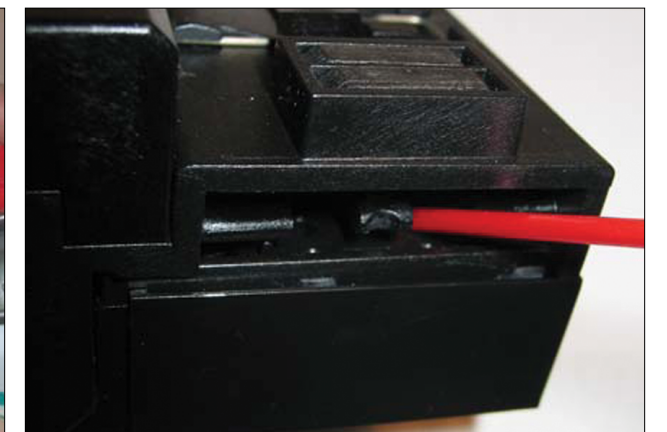

Location of the optical sensor within coin outlet.



# 50Lb. Express Coin Micro Switch Schematic 208-240V

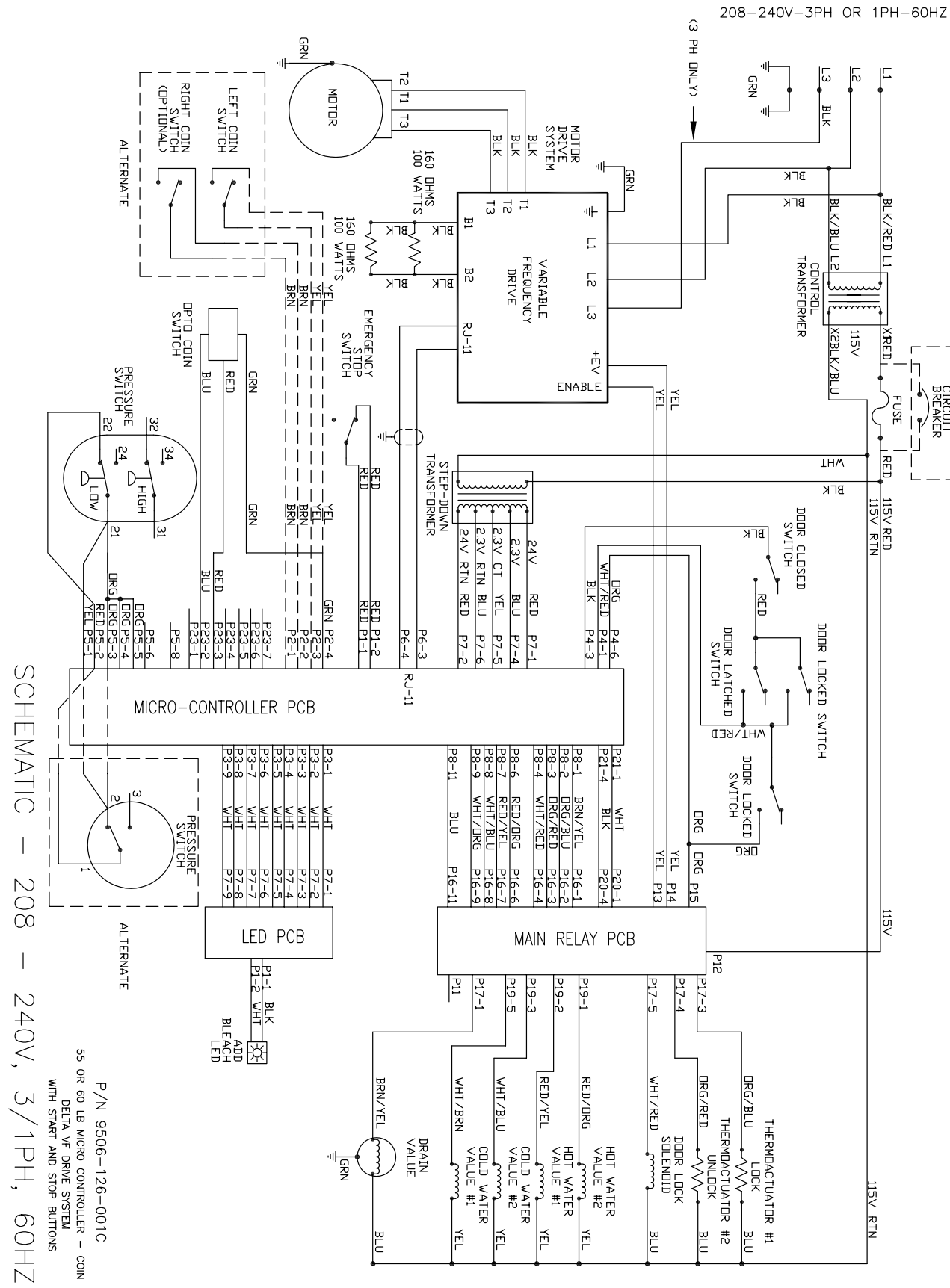

# 50Lb. Express Coin Micro Switch Diagram 208-240V

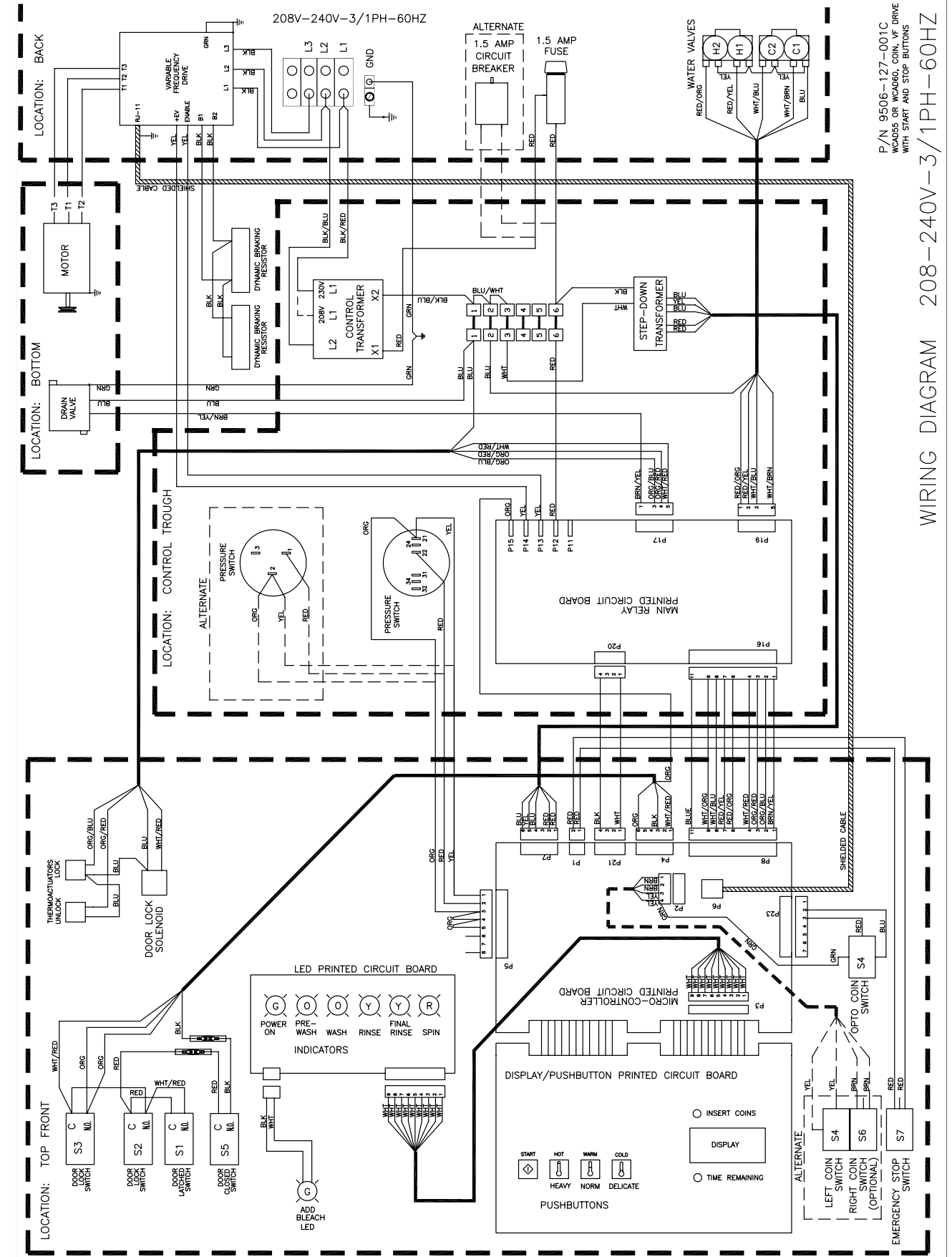

## US coin 50lb Express WCAD50KCB-USSZ Schematic (Optical)

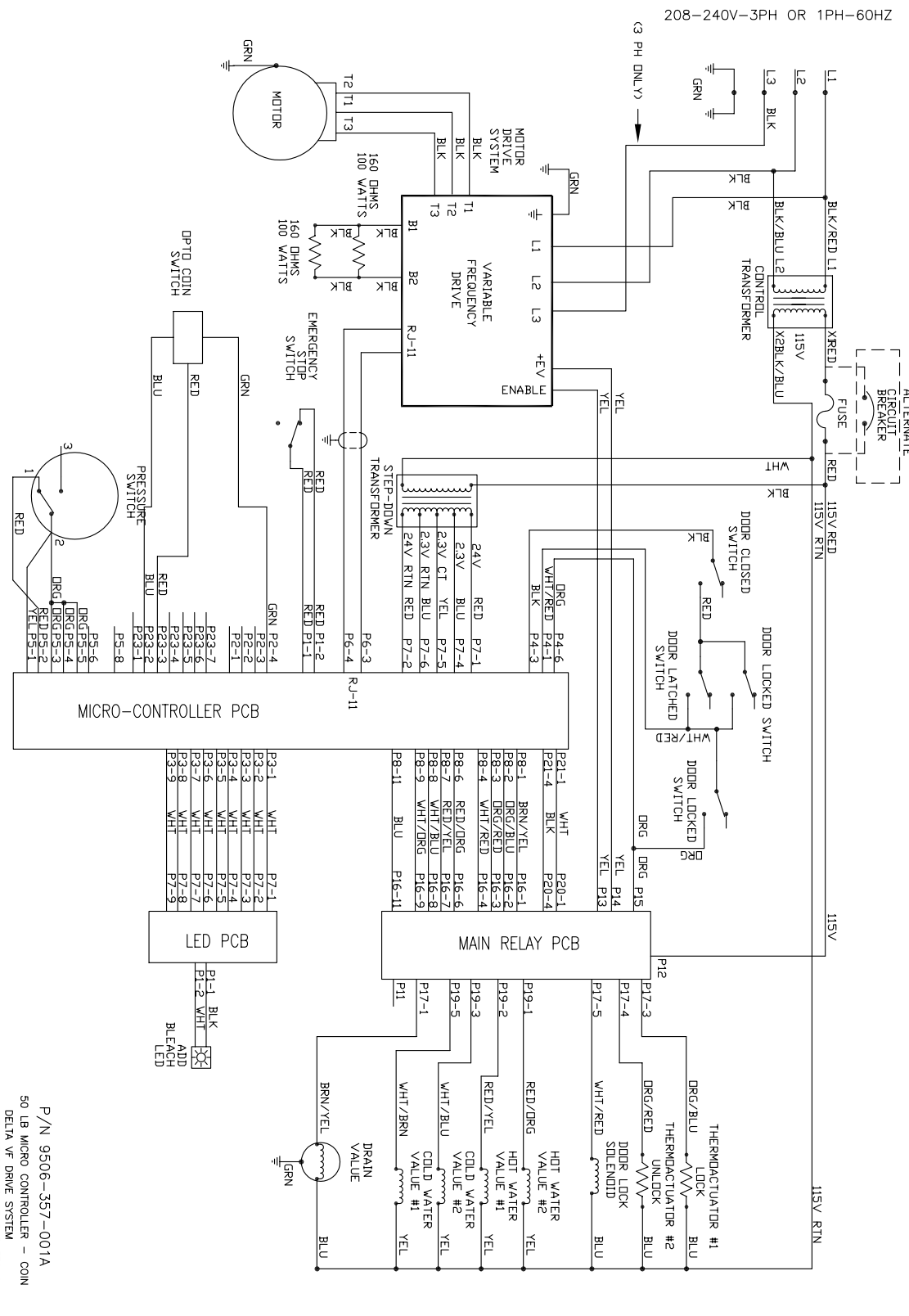

SCHEMATIC - 208 - 240V, 3/1PH, 60HZ

P/N 9506-357-001A  
50 LB MICRO CONTROLLER - COIN  
DELTA VF DRIVE SYSTEM  
WITH START AND STOP BUTTONS

## US coin 50lb Express WCAD50KCB-USSZ Diagram (Optical)

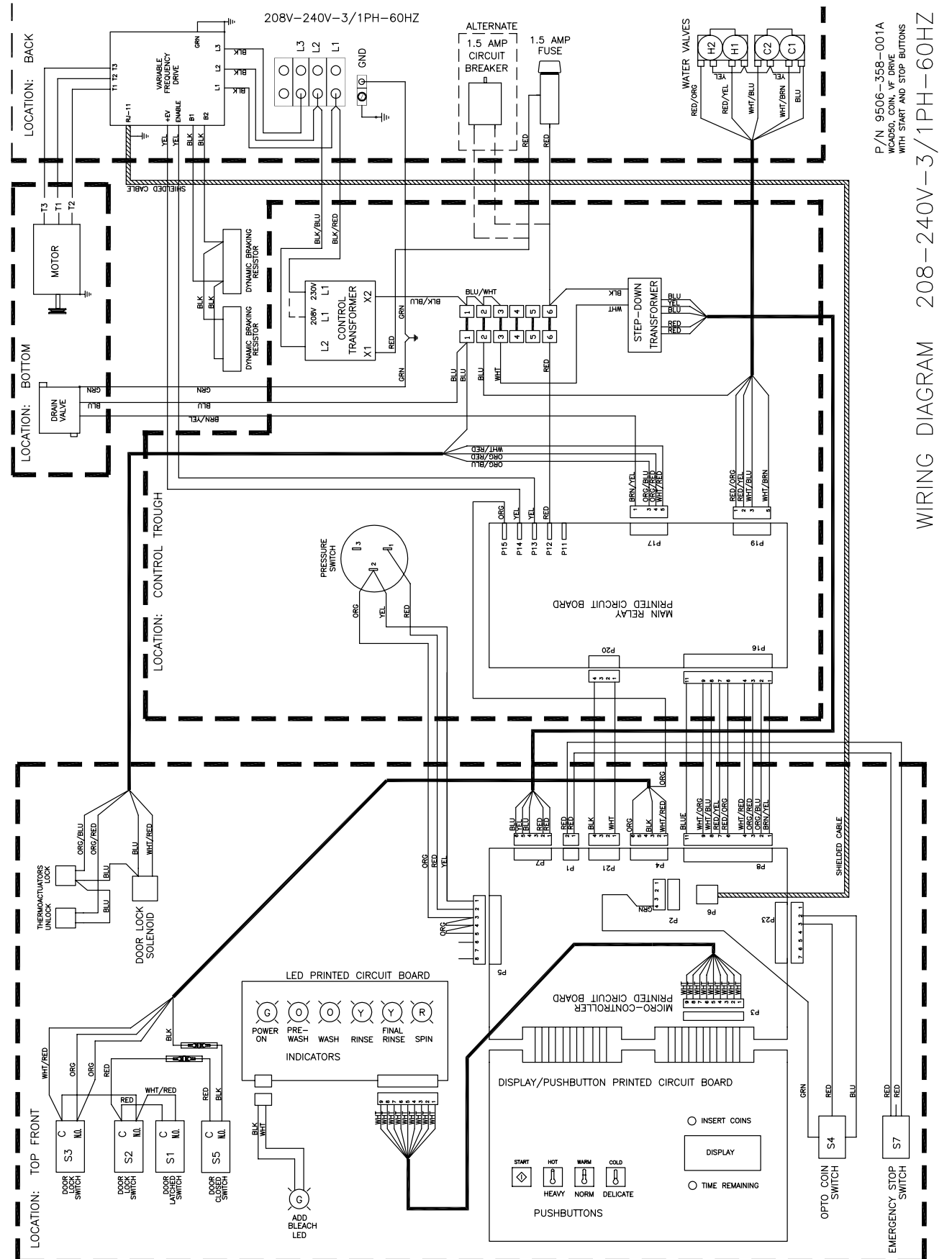

P/N 9506-358-001A  
WCAD50 COIN VF DRIVE  
WITH START AND STOP BUTTONS

WIRING DIAGRAM 208-240V-3/1PH-60HZ

# 50Lb. Express Electronic Acceptor Schematic 208-240V

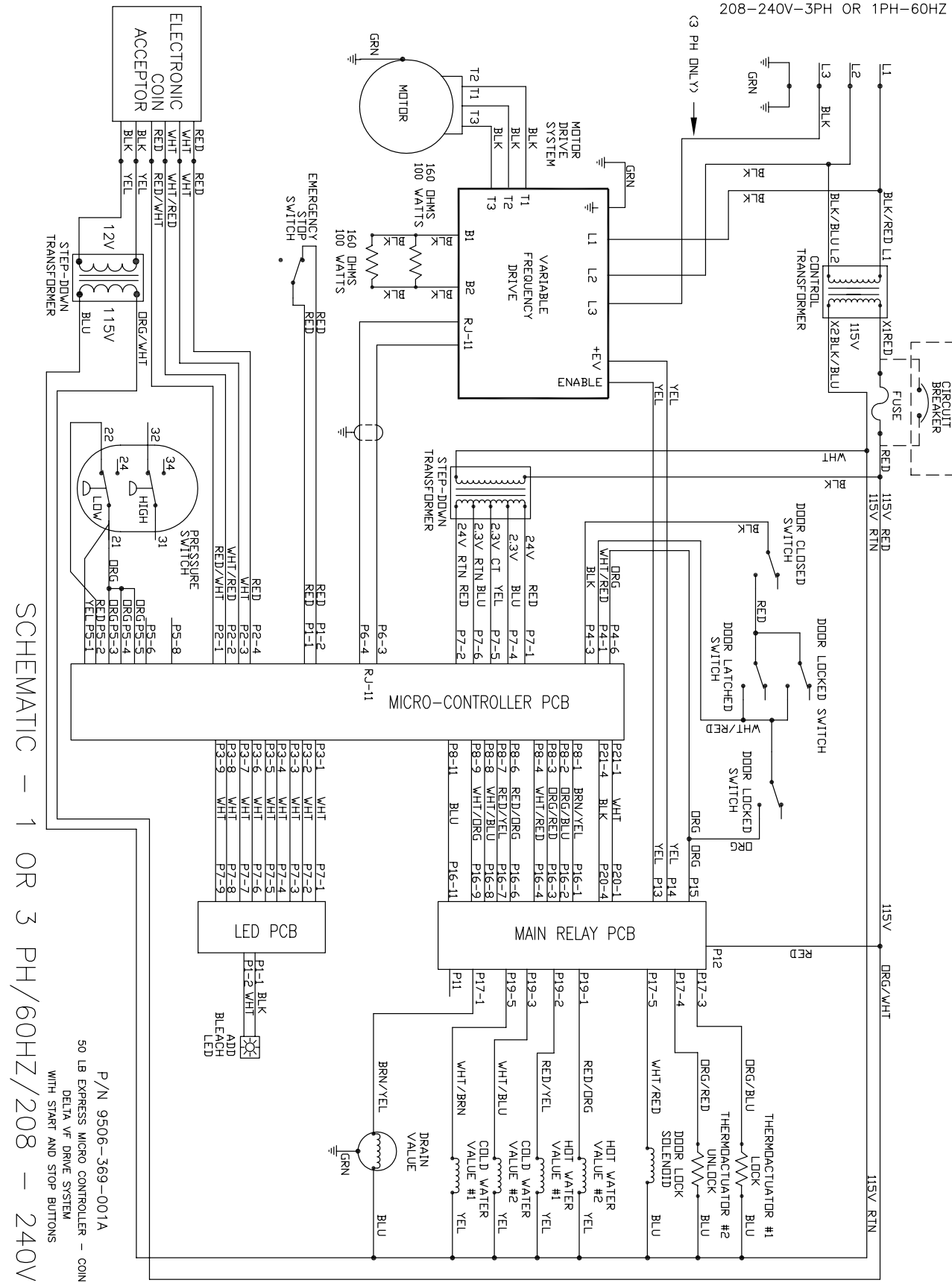

# 50Lb. Express Electronic Acceptor Diagram 208-240V

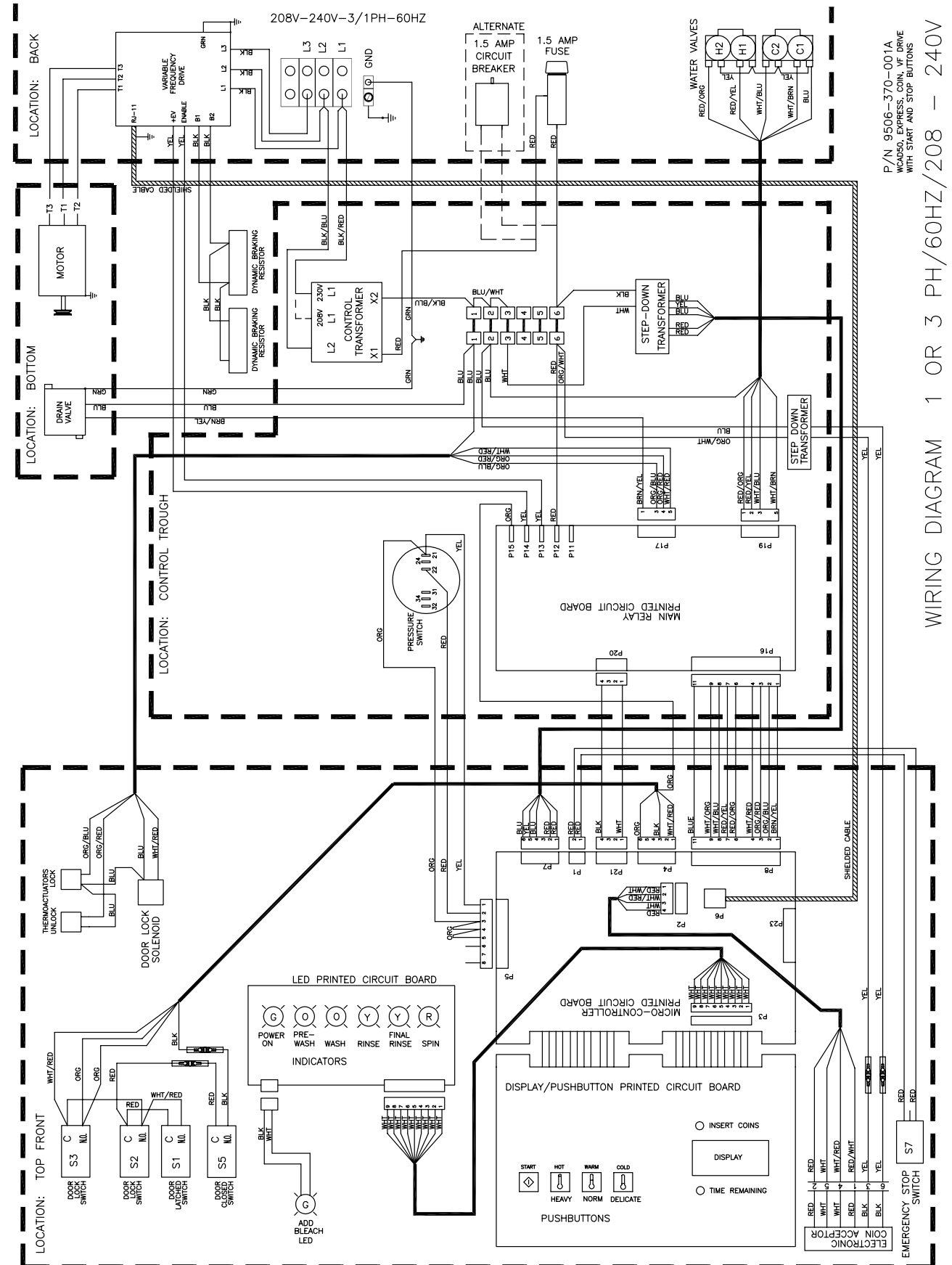

# 60Lb. Non-Express Coin Micro Switch Schematic

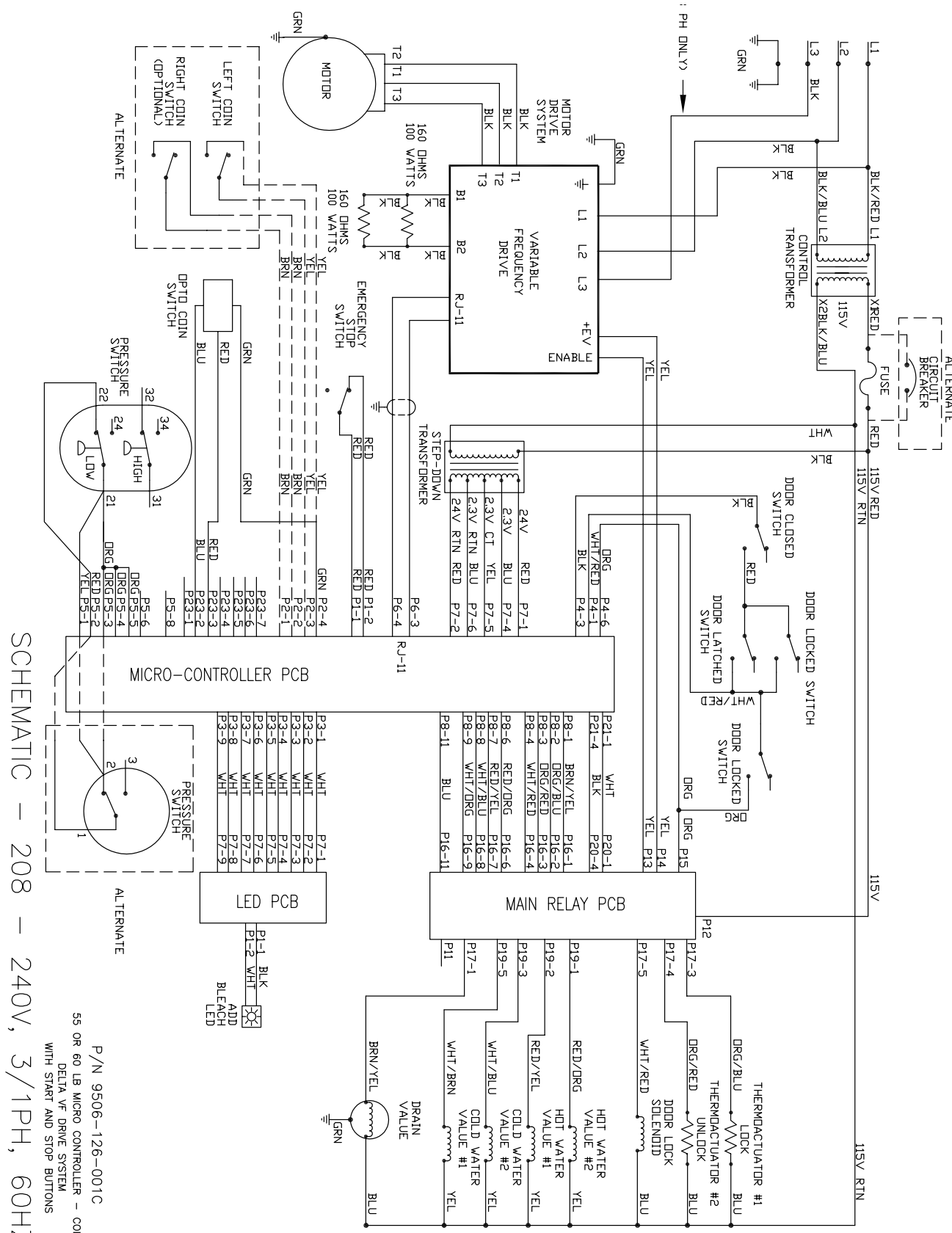

SCHEMATIC - 208 - 240V, 3/1PH, 60HZ

P/N 9506-126-001C  
55 OR 60 LB MICRO CONTROLLER - COIN  
DELTA VF DRIVE SYSTEM  
WITH START AND STOP BUTTONS

# 60Lb. Non-Express Coin Micro Switch Diagram

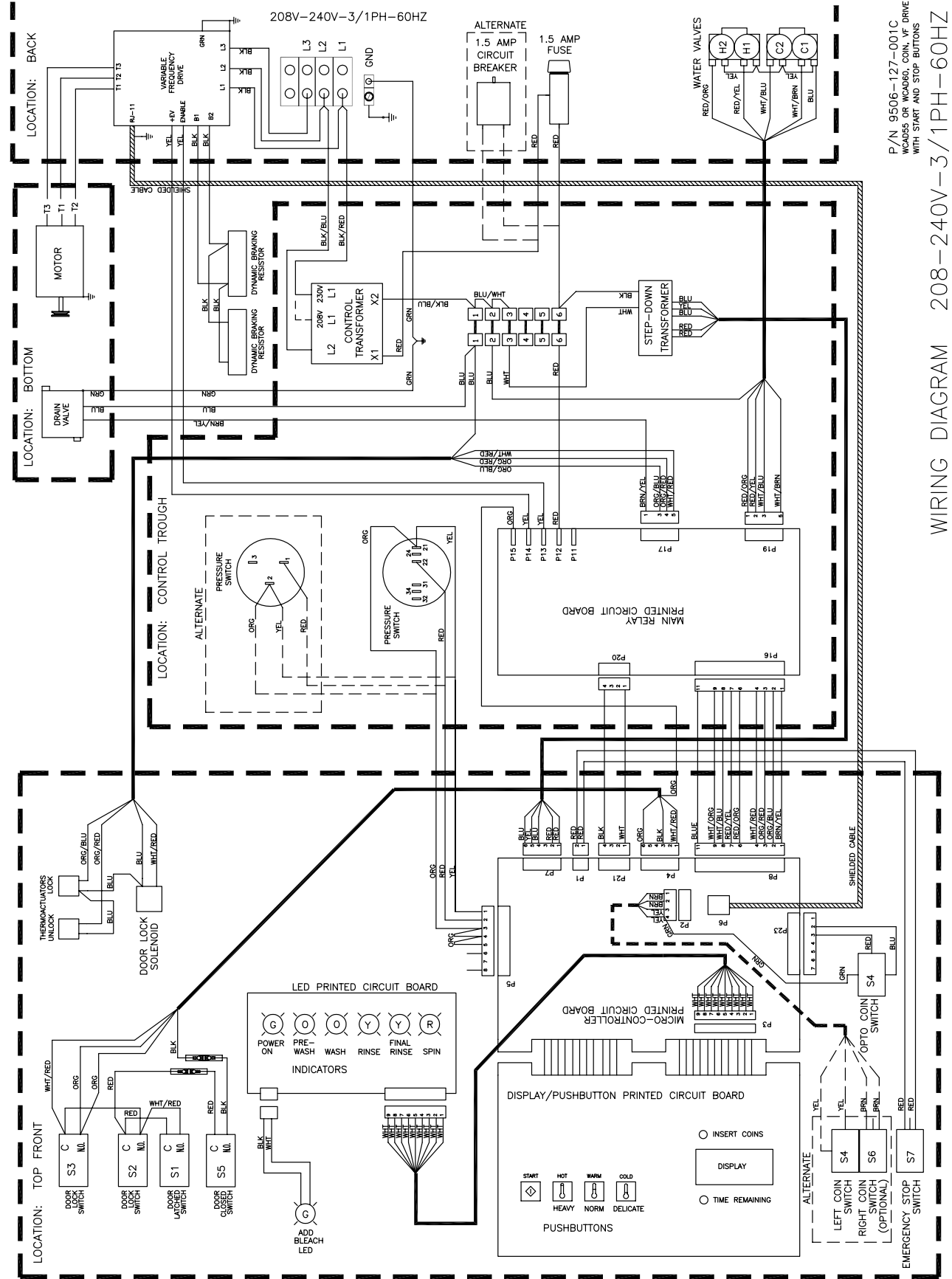

P/N 9506-127-001C  
WC485 OR WC486, COIN, VF DRIVE  
WITH START AND STOP BUTTONS

WIRING DIAGRAM 208-240V-3/1PH-60HZ



# 60Lb. Non- Express Electronic Acceptor Schematic 208-240V

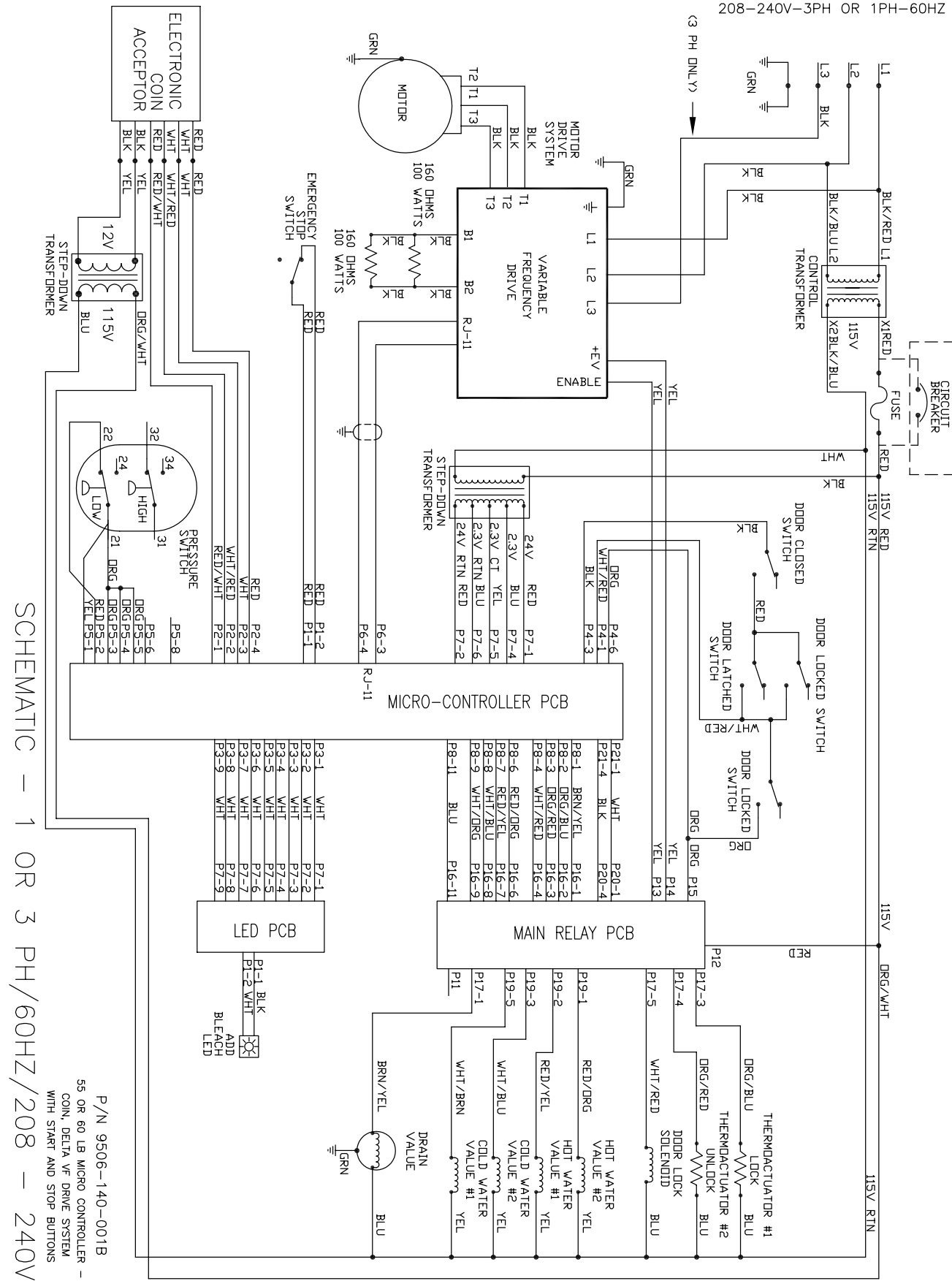

SCHEMATIC - 1 OR 3 PH/60HZ/208 - 240V

# 60Lb. Non- Express Electronic Acceptor Diagram 208-240V

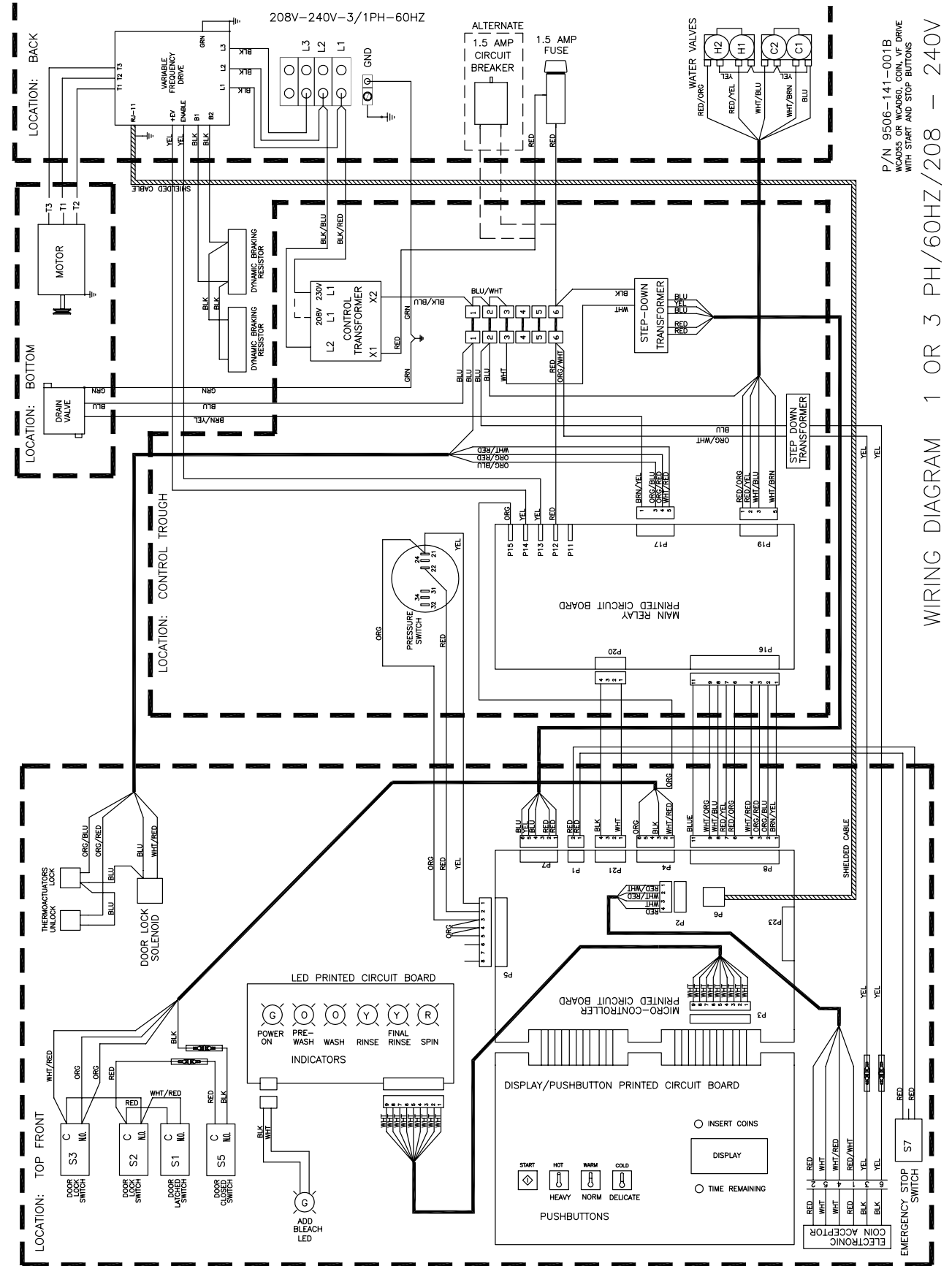

WIRING DIAGRAM 1 OR 3 PH/60HZ/208 - 240V









# US coin 80lb WCAD80KCB-US Schematic

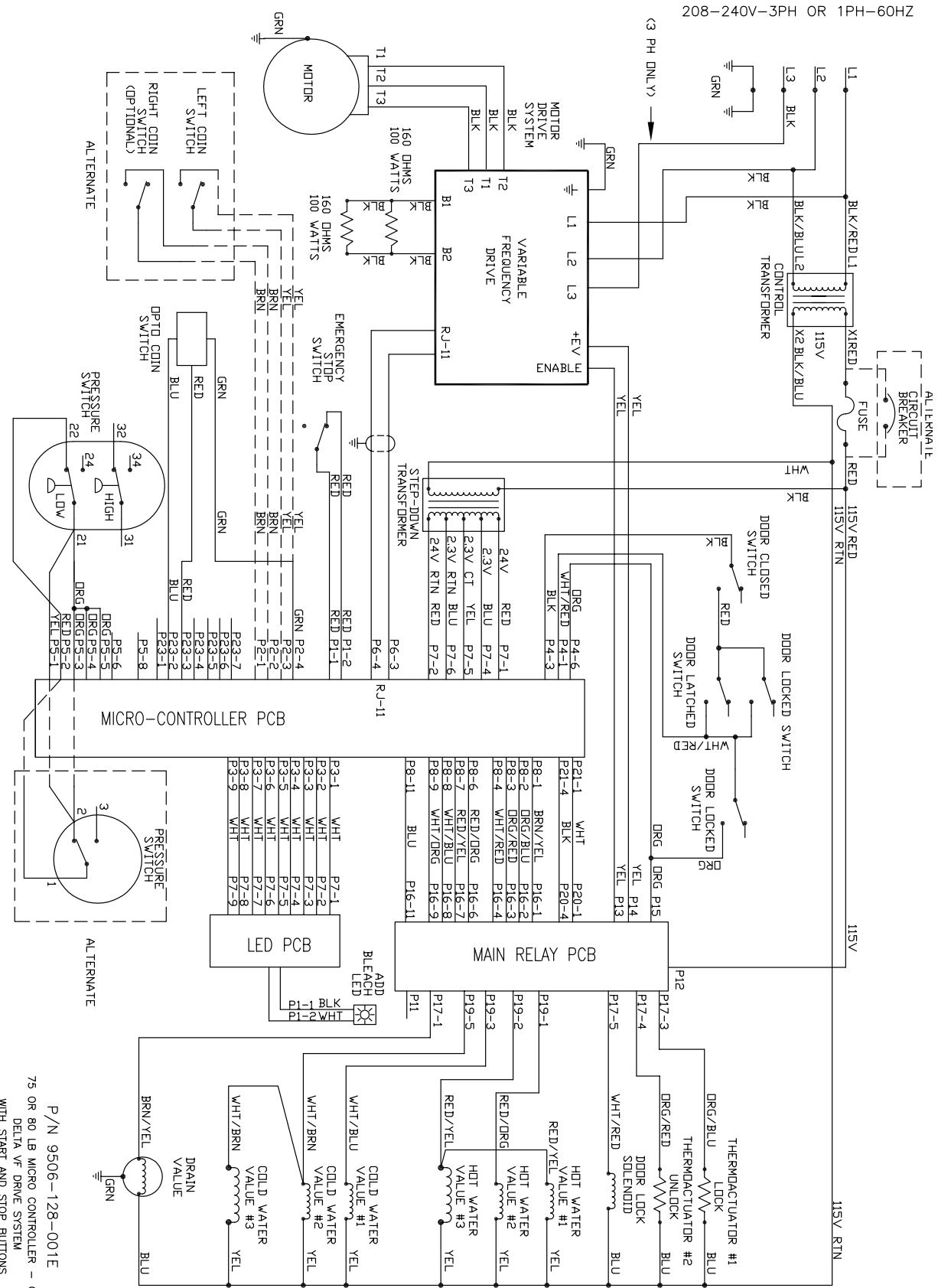

SCHEMATIC - 208 - 240V, 3/1PH, 60HZ

P/N 9506-128-001E  
75 OR 80 LB MICRO CONTROLLER - CON  
DELTA VF DRIVE SYSTEM  
WITH START AND STOP BUTTONS

# US coin 80lb WCAD80KCB-US Diagram

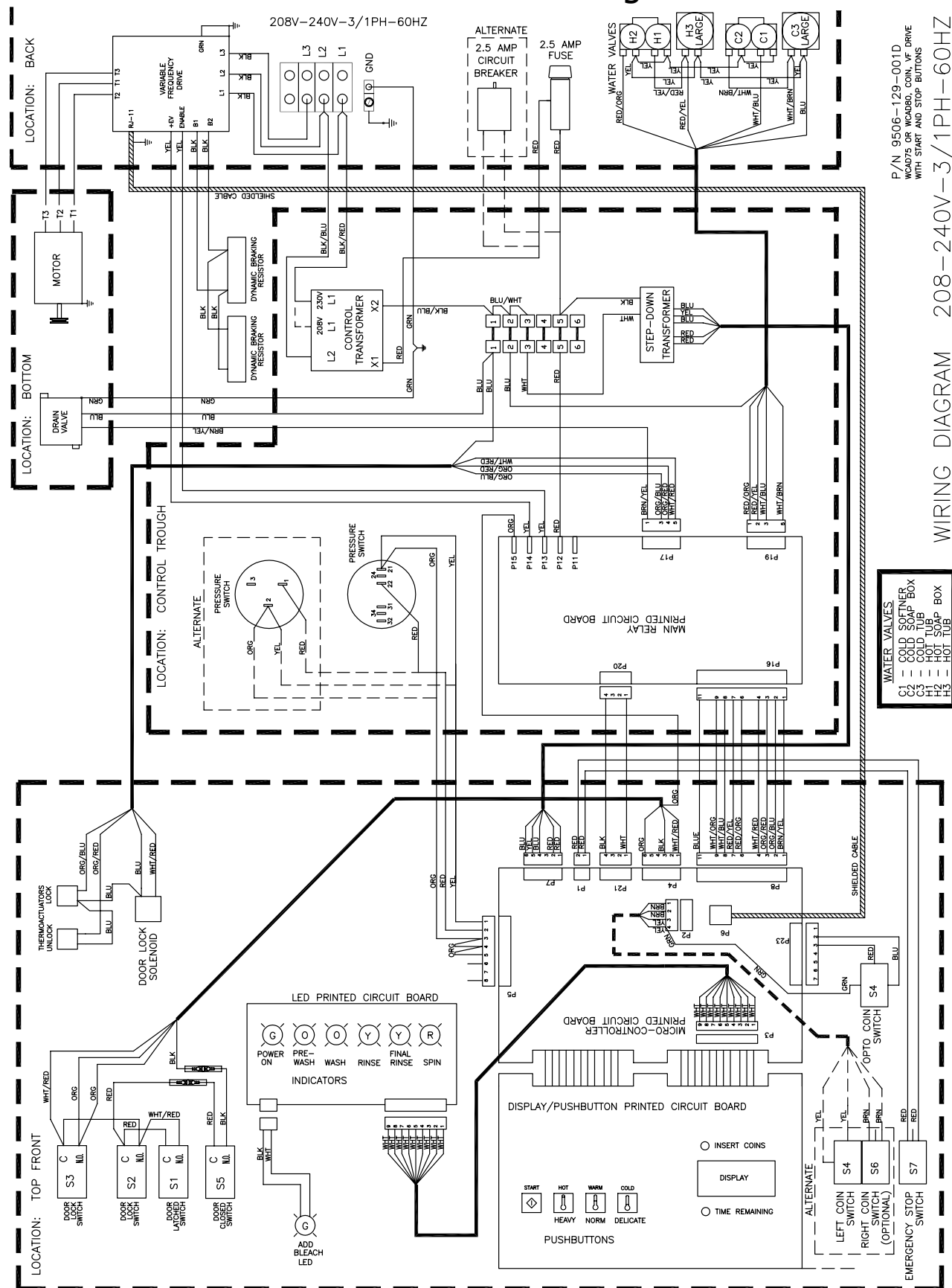

P/N 9506-129-001D  
WCAD75 OR WCAD80, CON, VF DRIVE  
WITH START AND STOP BUTTONS

WIRING DIAGRAM 208-240V-3/1PH-60HZ

WATER VALVES  
H2 - COLD SOAP BOX  
H1 - COLD TUB  
H3 - HOT SOAP BOX  
C2 - COLD TUB  
C1 - HOT TUB

# 80Lb. Non- Express Electronic Acceptor Schematic 208-240V

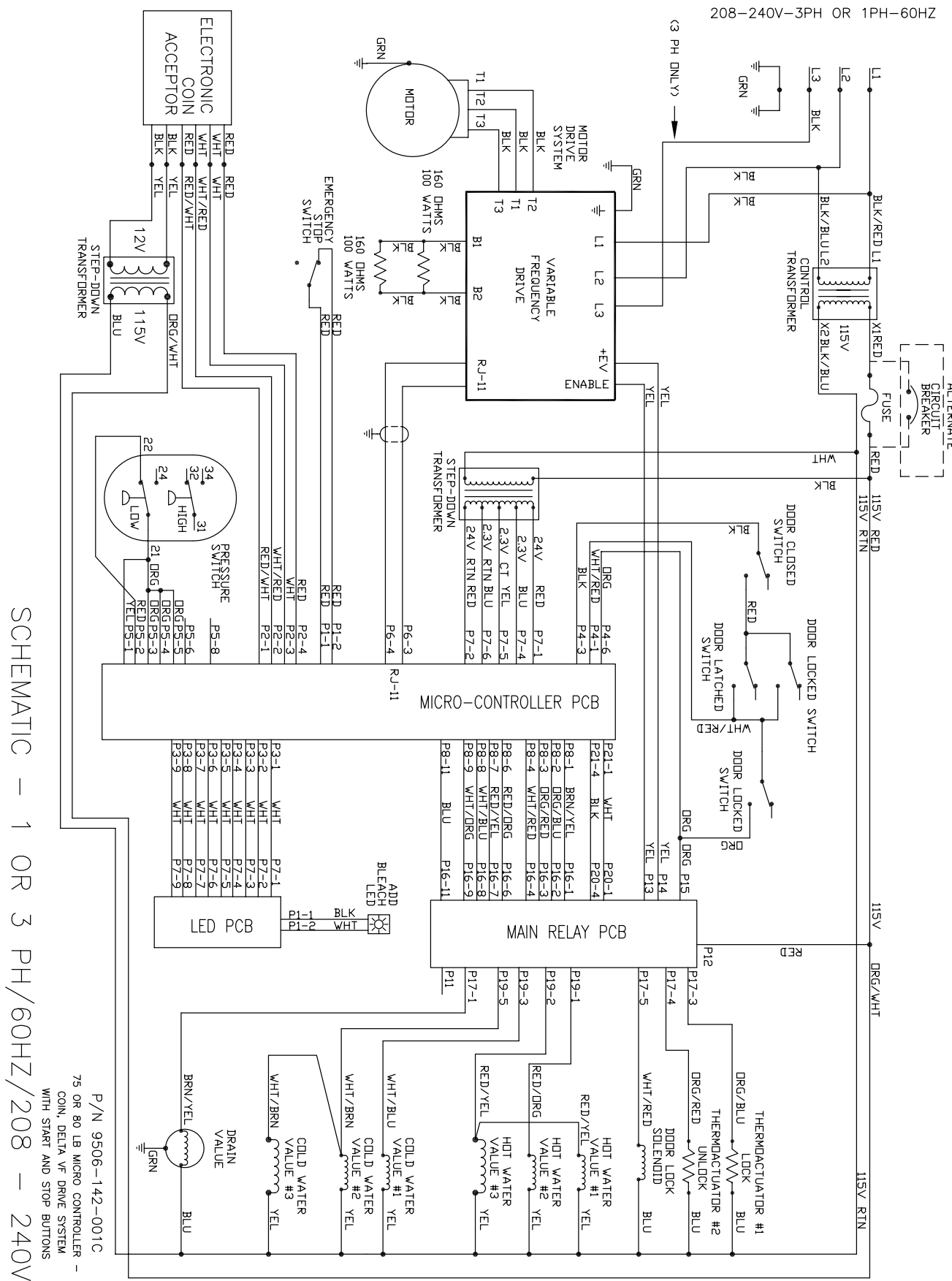

SCHEMATIC - 1 OR 3 PH/60HZ/208 - 240V

P/N 9506-142-001C  
 75 OR 80 LB MICRO CONTROLLER -  
 COIN, DELTA V<sup>F</sup> DRIVE SYSTEM  
 WITH START AND STOP BUTTONS

# 80Lb. Non- Express Electronic Acceptor Diagram 208-240V

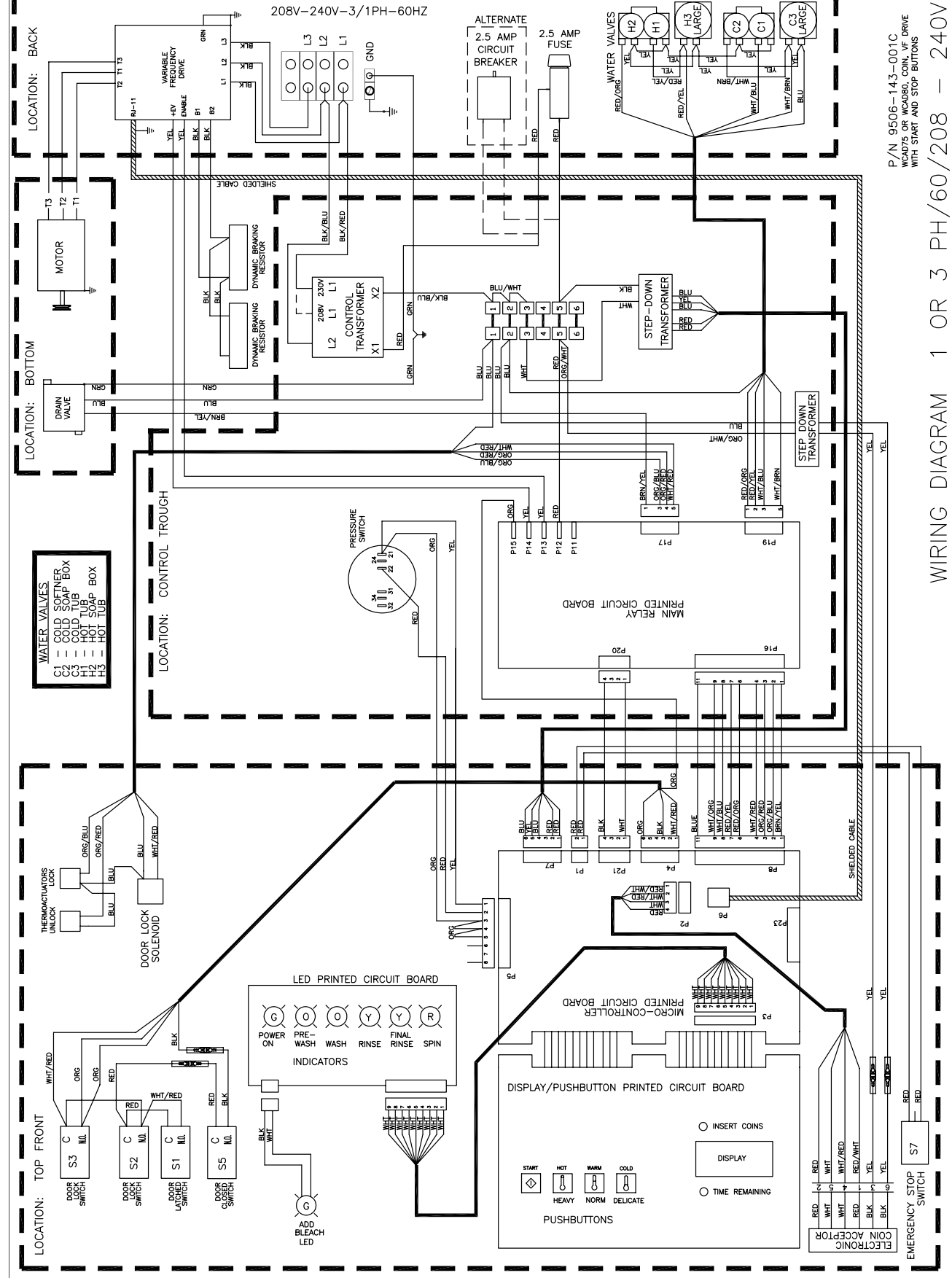

P/N 9506-143-001C  
 75 OR 80 LB MICRO CONTROLLER -  
 WITH START AND STOP BUTTONS

WIRING DIAGRAM 1 OR 3 PH/60/208 - 240V

# 90Lb. Express Immonex Acceptor Schematic 208-240V

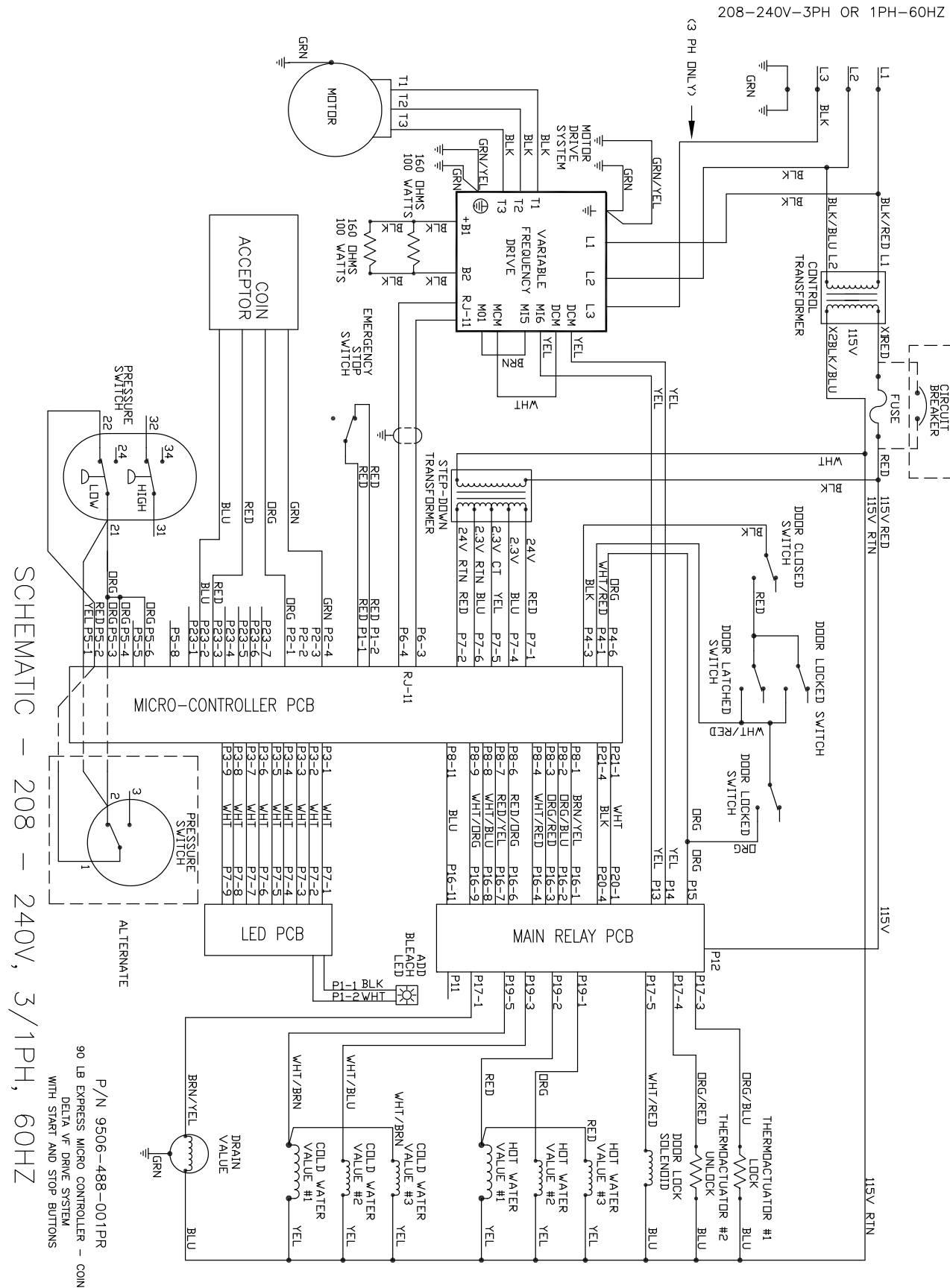

# 90Lb. Express Immonex Acceptor Diagram 208-240V

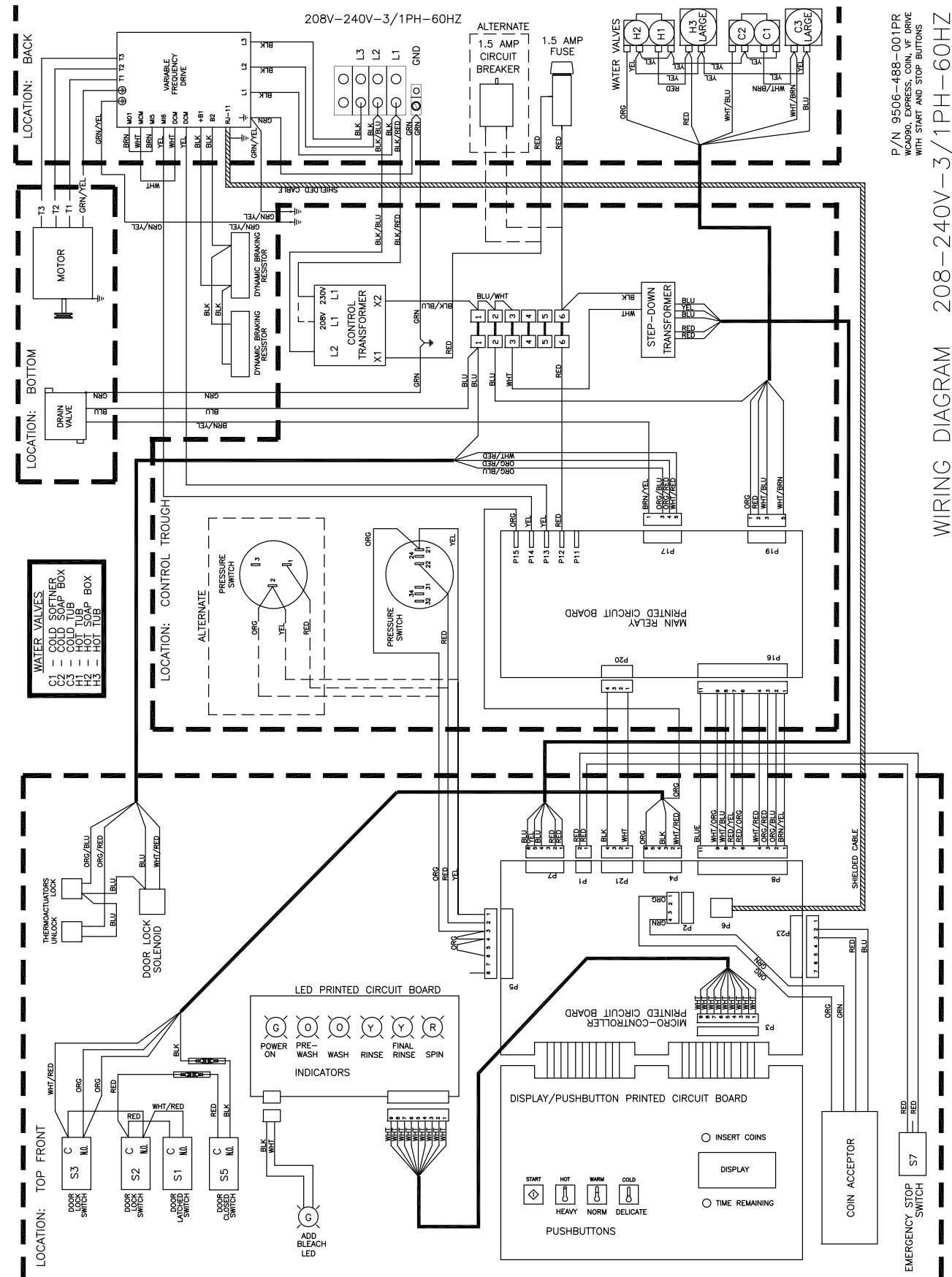

P/N 9506-488-001PR  
WCA90, EXPRESS, COIN, V-F DRIVE  
WITH START AND STOP BUTTONS

WIRING DIAGRAM 208-240V-3/1PH-60HZ



# Integrated Easy Card Control Panel Part # by Model

Key	Description	T-750	T-900	T-950	T-1200	T-1450	QTY
1	Panel Assembly (panel only)	9989-504-001	9989-504-001		9989-504-001	NA	1
*	Screw, Hxwshrhnduct #10Bx 1/2"	9545-008-026	9545-008-026		9545-008-026		4
2	Front Panel	9454-810-002	9454-810-002		9454-810-002		1
*	Post Locator Top	9467-024-001					2
*	Nut Hexkeps #6-32	8640-411-003	8640-411-003		8640-411-003		2
*	Locator Panel	9355-001-001	9355-001-001		9355-001-001		2
*	Screw FillHDCR 10Bx1/2"	9545-008-023	9545-008-023		9545-008-023		2
*	Spacer Pushbutton (Micro)	9538-178-001	9538-178-001		9538-178-001		1
*	Retainer Pushbutton (Micro)	9486-150-001	9486-150-001		9486-150-001		1
*	Nut Hexelasticstop #6-32	8640-411-003	8640-411-003		8640-411-003		2
5	Pushbutton Control (coin)	9035-060-003	9035-060-003		9035-060-003		1
6	PCB assembly Control /Display STOP	9473-009-002	9473-009-002		9473-009-002		1
*	Spacer Plastic #6x9/16	9538-157-018	9538-157-018		9538-157-018		5
*	Nut Elasticstop #6-32	8640-411-002	8640-411-002		8640-411-002		5
*	Harness LEDPCB	9627-797-001	9627-797-001		9627-797-001		1
4	Harness Doorlock	9627-791-003	9627-791-003		9627-791-003		1
7	PCB assembly Mode lights	9473-005-001	9473-005-001		9473-005-001		1
*	Spacer Plastic #6x9/16	9538-157-018	9538-157-018		9538-157-018		2
*	Nut Hexkeps #6-32	8640-411-003	8640-411-003		8640-411-003		2
8	Light, LED,ADD BLEACH Assembly	9794-001-001	9794-001-001		9794-001-001		1
*	Spacer Plastic #6x9/16	9538-157-018	9538-157-018		9538-157-018		2
*	Nut Hexeps #6-32	8640-411-003	8640-411-003		8640-411-003		2
9	Nameplate,Control Panel (one piece)	9412-144-001	9412-158-001		9412-146-001		1
10	Switch Assembly Emergency Stop	9732-223-001	9732-223-001		9732-223-001		1
11	Solenoid Ass'y, Door Locking (see Door Lock Group for parts breakdown)	9922-011-001	9922-011-001		9922-011-001		1
16	Hex Nuts (mounting solenoid assy. to control panel)	8640-412-005	8640-412-005		8640-412-005		3
12	Battery	8612-001-001	8612-001-001		8612-001-001		1
13	Harness V-reader ALL MODELS	9627-827-001	9627-827-001		9627-827-001		1
14	Card Reader Assembly Complete	9797-007-003	9797-007-003		9797-007-003		1
15	Cable Assembly 4 twisted pair 12' shld/unshld reader to rear of machine	9806-013-002	9806-013-002		9806-013-002		1
*	Mounting plate for card reader	9982-337-001	9982-337-001		9982-337-001		1

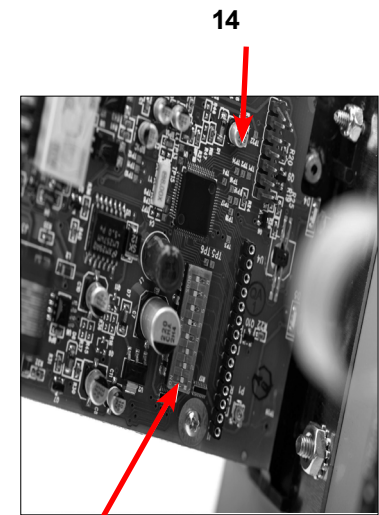
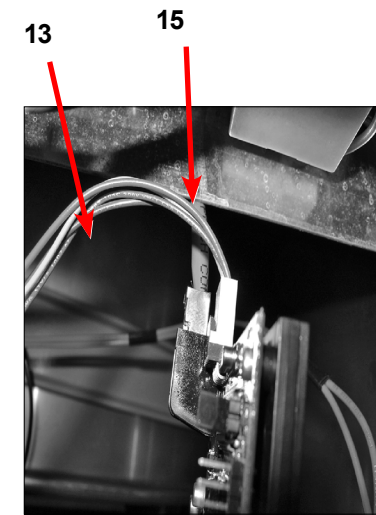

**Reader Wire  
Harness  
Connection**

**Address Switch**

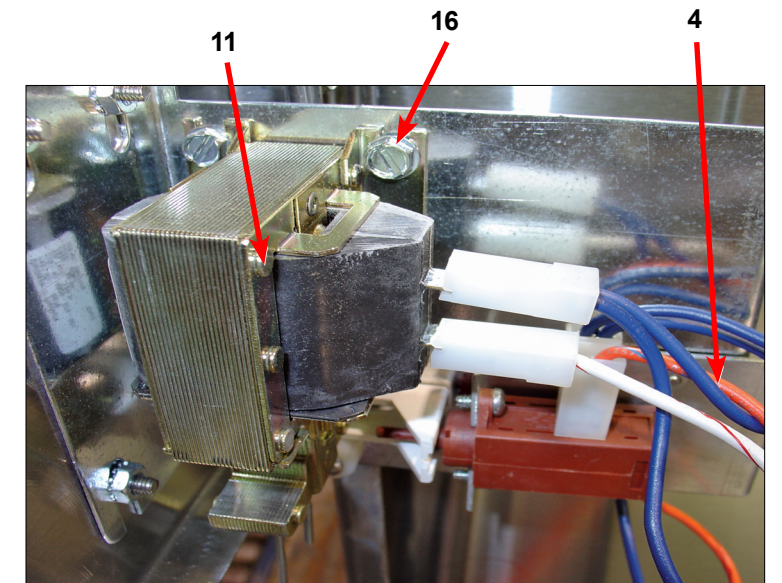
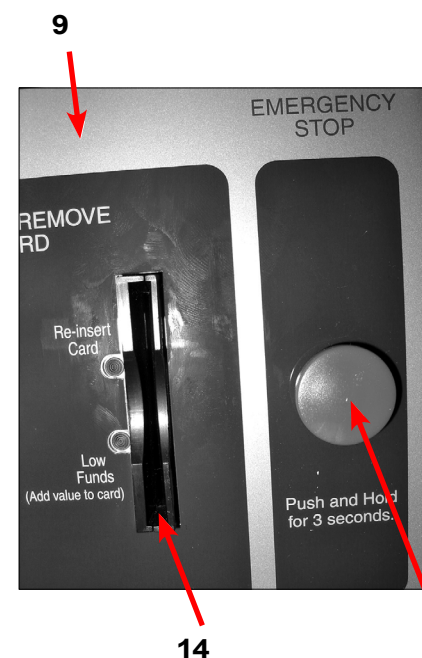
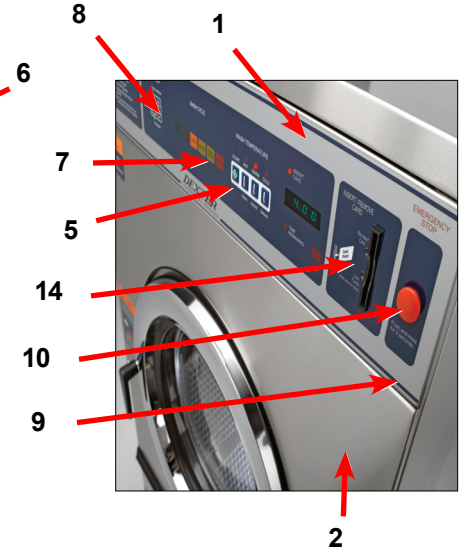
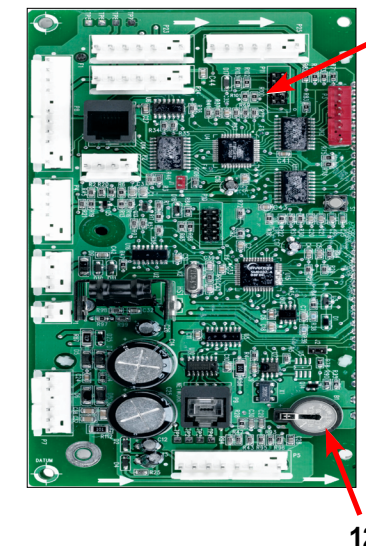
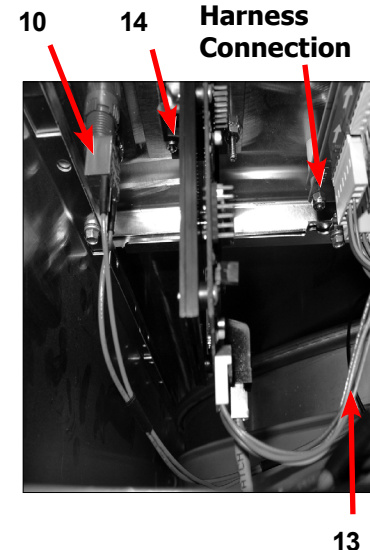

# Converted Easy Card 50Lb. Express 208-240 Volt Wiring Schematic

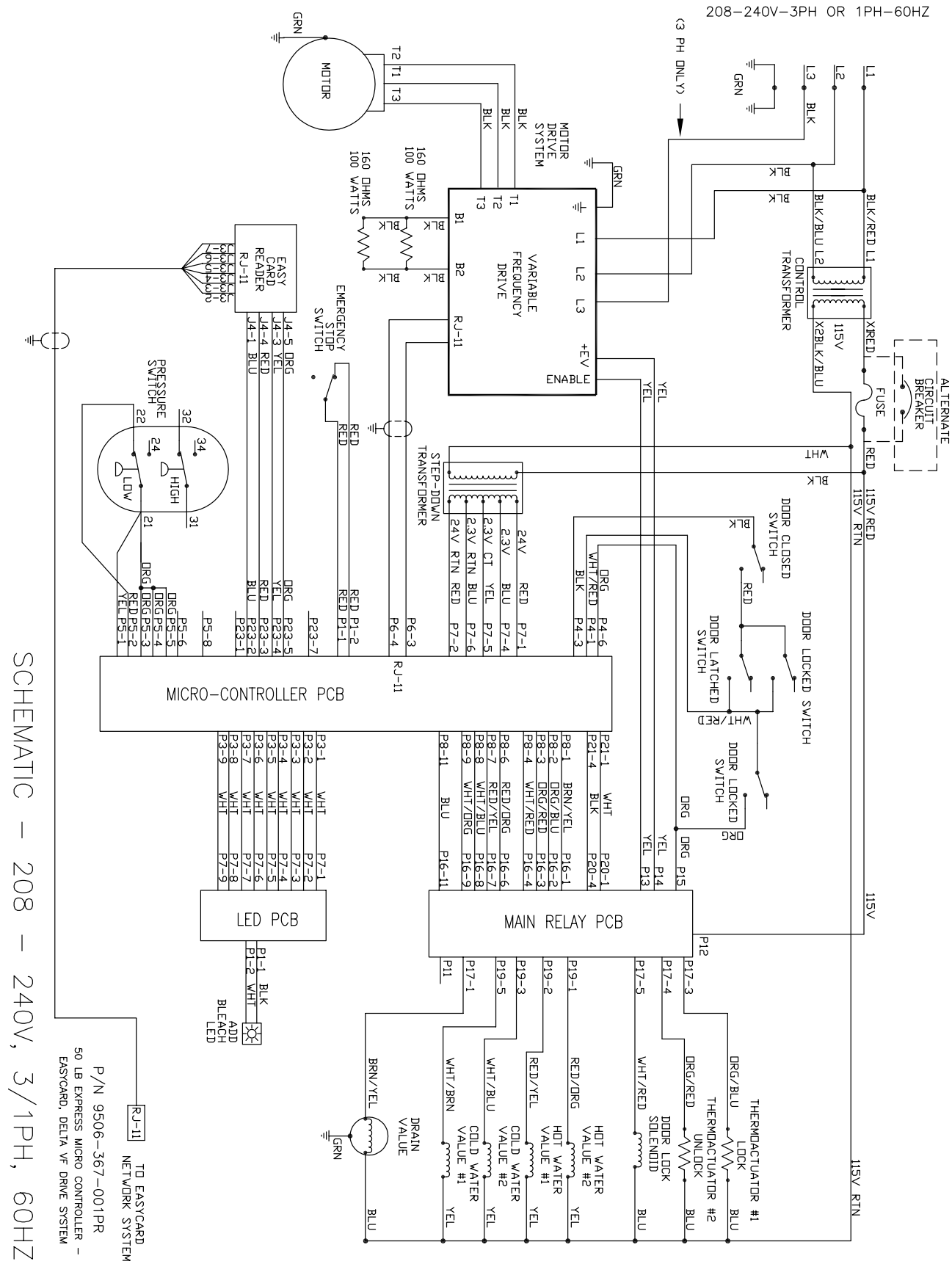

SCHEMATIC - 208 - 240V, 3/1PH, 60HZ

# Converted Easy Card 50Lb. Express 208-240 Volt Wiring Diagram

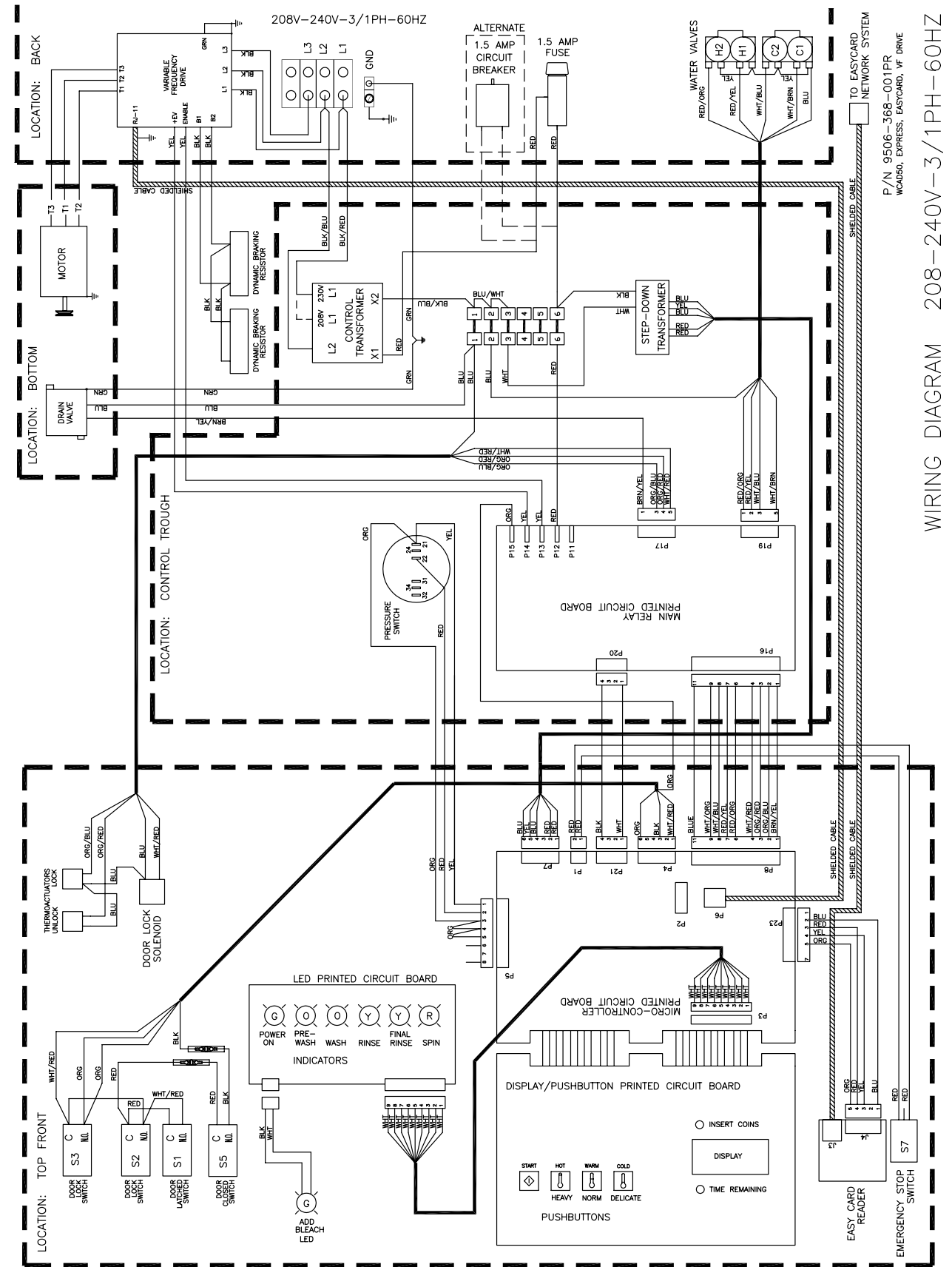

WIRING DIAGRAM 208-240V-3/1PH-60HZ









## Transformer, Electrical Filter and Coin Handling -59 models

Key	Component	T-750	T-900	T-950	T-1200	T-1450	QTY
1	Circuit Breaker	5198-211-002	5198-211-002		5198-211-002		1
*	Wire Assembly Black / Red	8220-001-232	8220-001-232		8220-061-003		1
*	Wire Assembly Black / Blue	8220-001-233	8220-001-233		8220-061-004		1
*	Wire Assembly Red	8220-001-282	8220-001-282		8220-001-282		1
*	Wire Assembly Black / Blue	8220-065-007	8220-065-007		8220-065-007		1
*	Wire Assembly Red	8220-065-011	8220-065-011		8220-065-011		1
*	Instructions, Transformer Connect	8507-230-003	8507-230-003		8507-230-003		1
*	Owners Booklet	8514-116-001	8514-116-001		8514-120-001		1
*	Nut #8-32	8640-412-005	8640-412-005		8640-412-005		13
*	Nut #10-32	8640-413-002	8640-413-002		8640-413-002		28
*	Lockwasher - Extooth #6	8641-582-005	8641-582-005		8641-582-005		2
2	Controls Transformer	8711-008-002	8711-008-002		8711-008-002		1
3	Transformer	8711-009-003	8711-009-003		8711-009-003		1
4	Coin Acceptor - Electronic	9021-011-001	9021-011-001		9021-011-001		1
5	Harness - Electronic Coin Acceptor	9627-845-001	9627-845-001		9627-845-001		1
*	Bracket Terminal/Filter Mounting	9029-188-001	9029-188-001		9029-170-001		1
*	Standoff, Twistloc				9527-002-002		6
*	Rear Channel 18lb OPL	9081-132-002	9081-132-002				1
6	EMI Line Filter	9183-030-003	9183-030-003				1
7	EMI Filter 1 ph, 20 Amp	9183-040-001	9183-040-001		9183-040-001		1

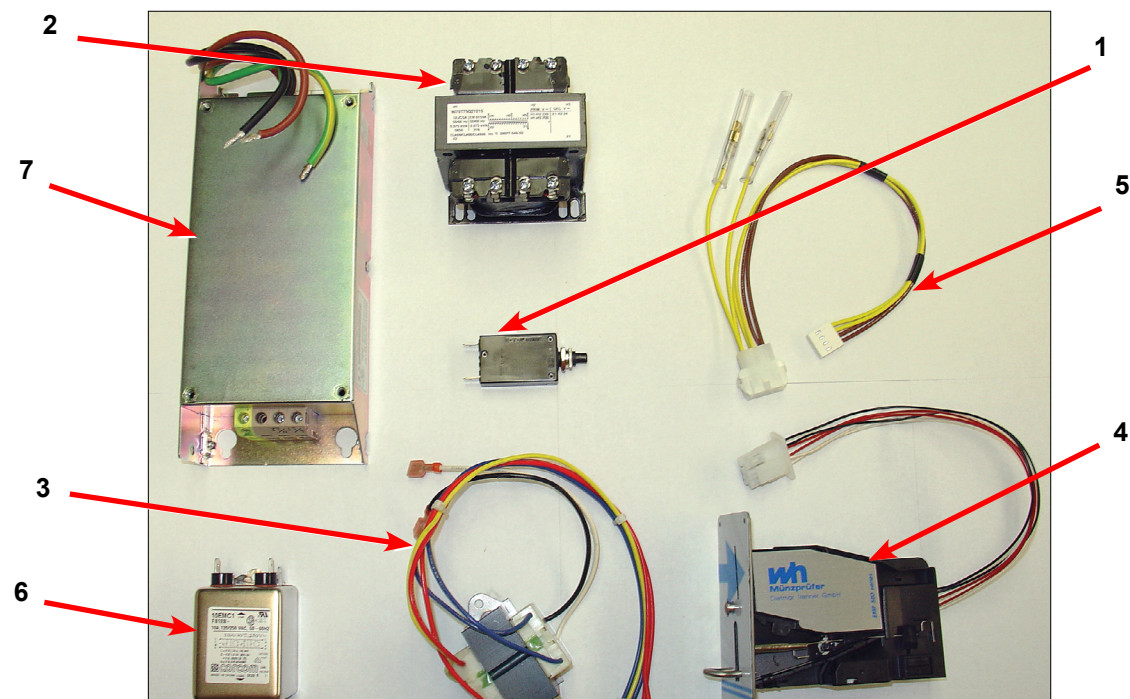

## Water Valve, Drain Valve and Door Locking -59 models

Key	Component	T-750	T-900	T-950	T-1200	T-1450	QTY
1	Water Valve	9379-183-013	9379-183-013		9379-183-013		2
3	Drain Valve 3" inch	9379-202-002	9379-202-002		9379-202-002		1
*	Filter Mounting Plate	9452-758-001	9452-758-001		9452-747-001		1
*	Wiring Label , Schematic	9506-263-001	9506-265-001		9506-271-001		1
*	Wiring Label , Diagram	9506-264-001	9506-266-001		9506-272-001		1
5	Solenoid, Door Lock	9536-082-001	9536-082-001		9536-082-001		1
*	Screw #10B - 32 X 1/2	9545-008-026	9545-008-026				52
*	Screw #10-32 TT X1/2	9545-008-027	9545-008-027		9545-008-027		3
*	Screw #8-32 X3/8	9545-010-006	9545-010-006		9545-010-006		2
*	Screw Hex 8B X1/4	9545-045-001	9545-045-001		9545-045-001		4
*	Terminal Strip Marker	9558-029-004	9558-029-004				1
6	Thermoactuator, 24V	9586-001-003	9586-001-003		9586-001-003		2
*	Wiring Harness, Power Terminal Block	9627-865-001	9627-865-001		9627-865-002		1
*	Controls Assembly - Trough,	9857-150-005	9857-150-005		9857-151-009		1
*	Door Lock Solenoid Assembly	9922-011-005	9922-011-005		9922-011-005		1
*	Filter Mounting Plate Assembly	9982-359-001	9982-359-001		9982-349-001		1
*	Nut #6-32						4
*	EMI Filter 1 ph, 20 Amp	9183-040-001	9183-040-001		9183-040-001		1
*	Filter Mounting Plate Assembly	9982-359-001	9982-359-001		9982-349-001		1
*	Nut #6-32						4

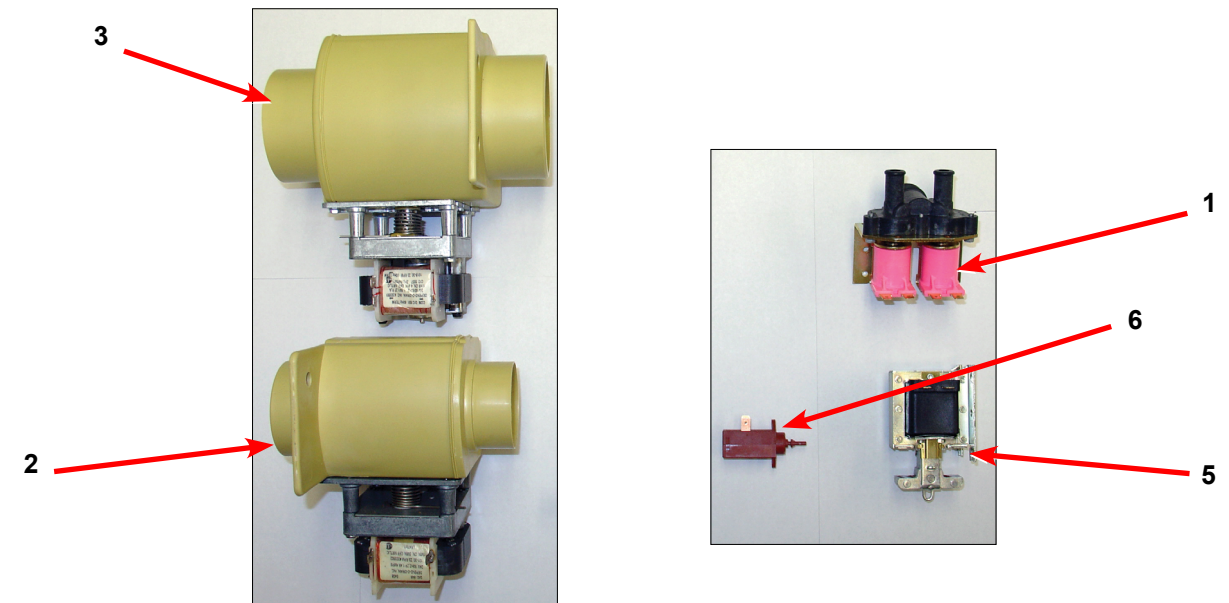



# WCAD50KCB -21CNSZ 230/50/1 Voltage Schematic

230V-1PH-50HZ

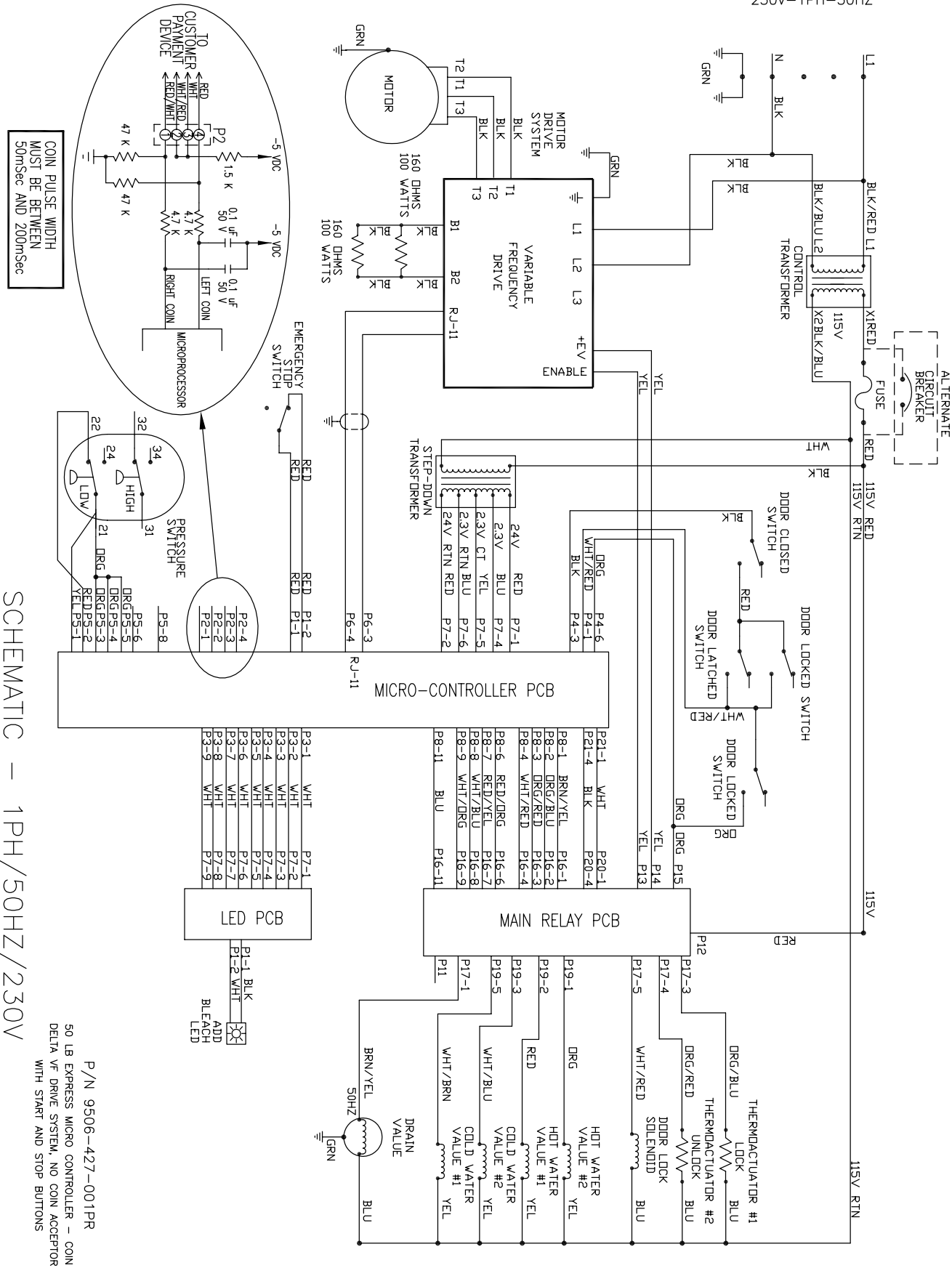

# WCAD50KCB -21CNSZ 230/50/1 Voltage Diagram

230V-1PH-50HZ

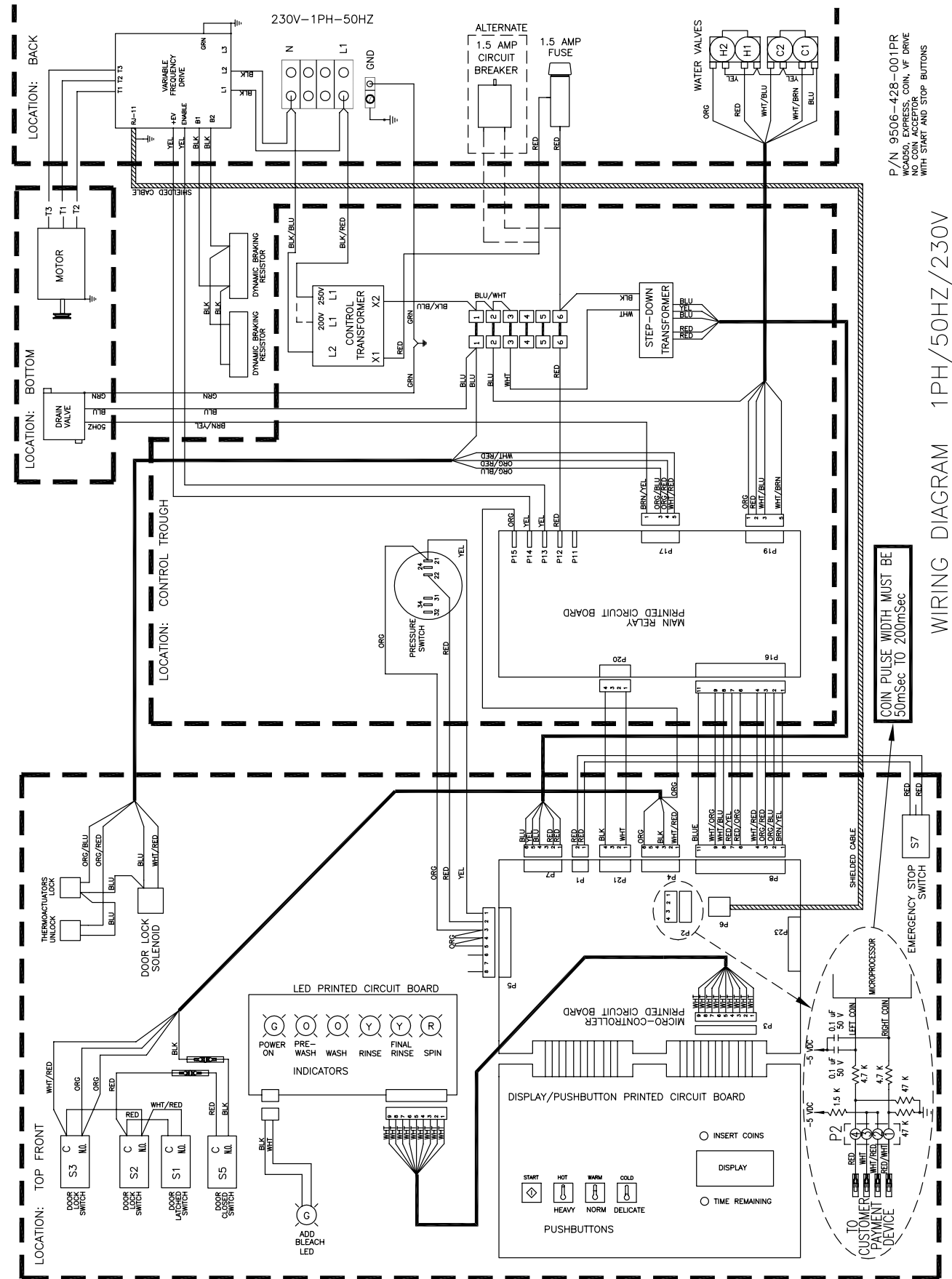

# WCAD50KCB -59CNSZ 230/50/1 Voltage Schematic

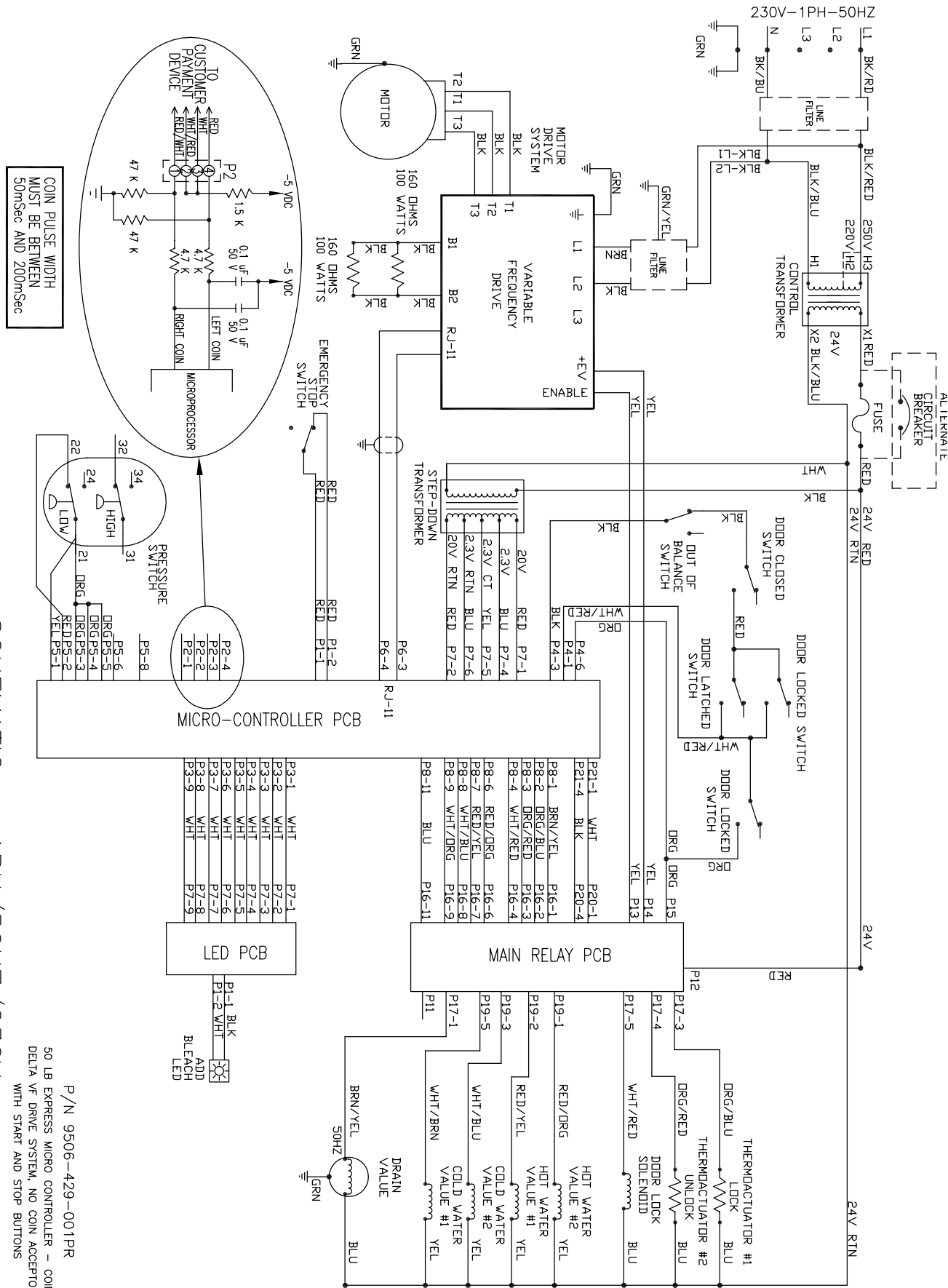

# WCAD50KCB -59CNSZ 230/50/1 Voltage Diagram

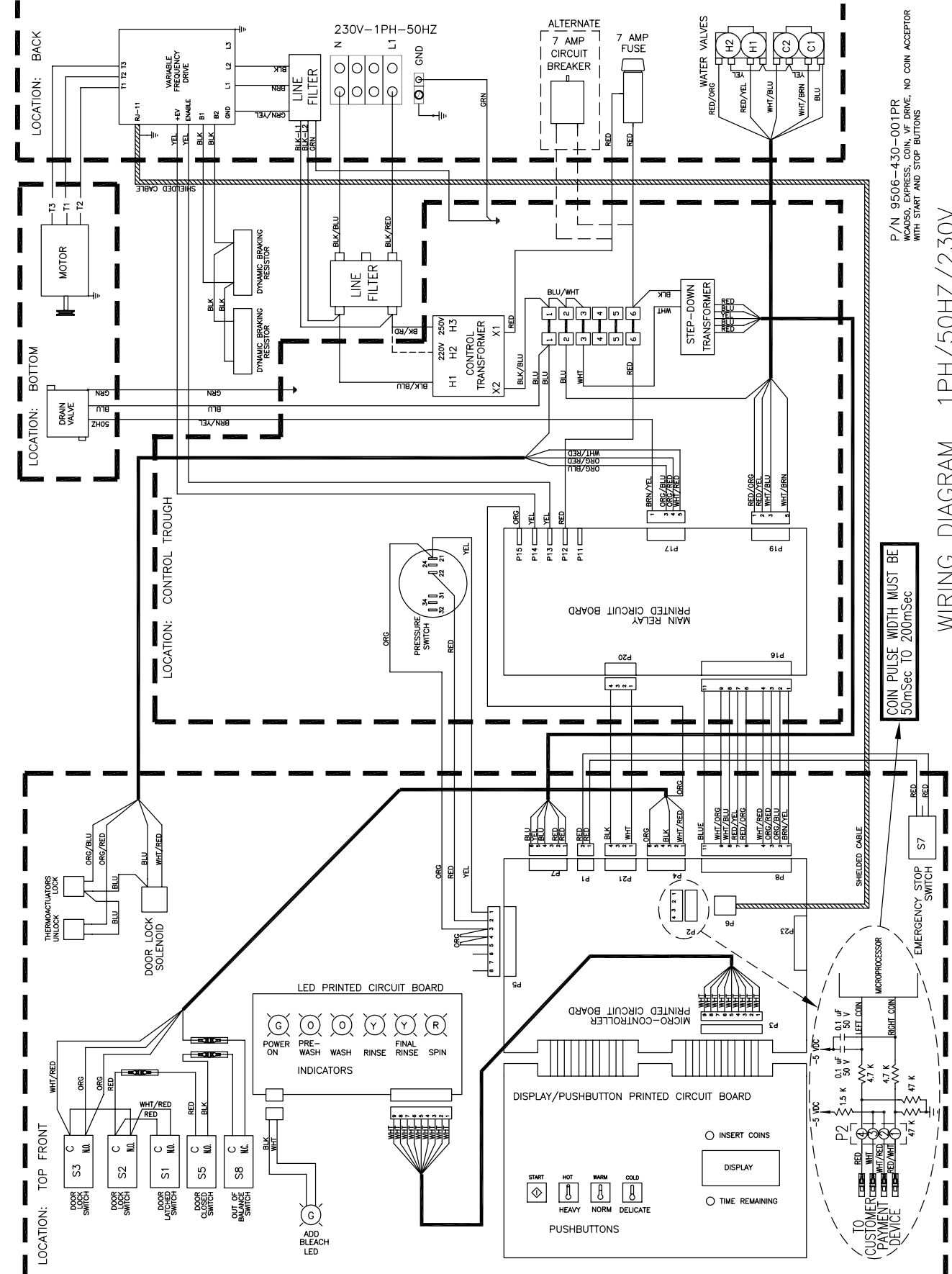

# WCAD60KCB -21CN 230/50/1 Voltage Schematic

230V-1PH-50HZ

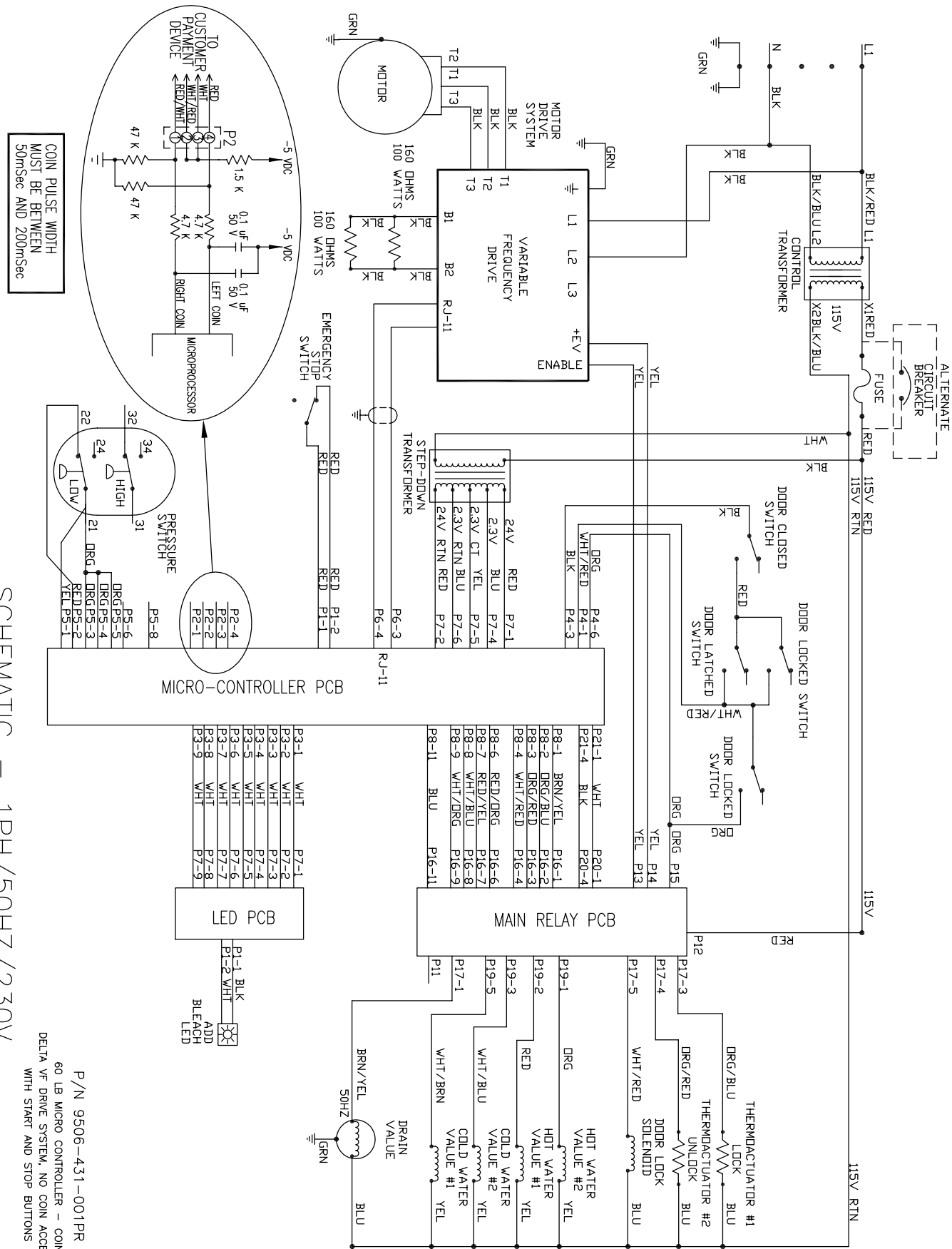

SCHEMATIC - 1PH/50HZ/230V

P/N 9506-431-001PR  
60 LB MICRO CONTROLLER - COIN  
DELTA VV DRIVE SYSTEM, NO COIN ACCEPTOR  
WITH START AND STOP BUTTONS

# WCAD60KCB -21CN 230/50/1 Voltage Diagram

230V-1PH-50HZ

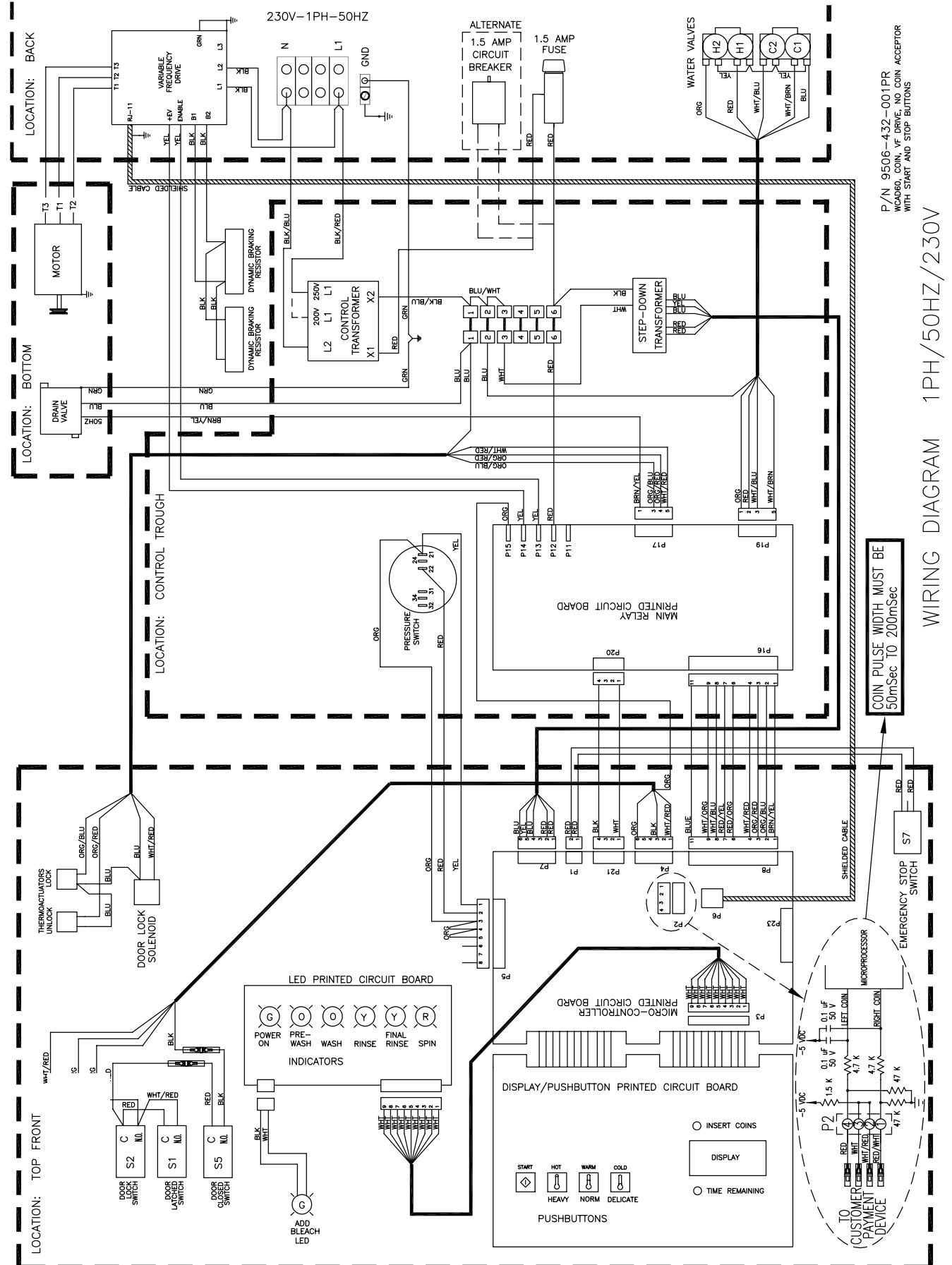

P/N 9506-432-001PR  
WCAD60, COIN, VV DRIVE, NO COIN ACCEPTOR  
WITH START AND STOP BUTTONS

WIRING DIAGRAM 1PH/50HZ/230V

COIN PULSE WIDTH MUST BE  
50mSec TO 200mSec

# WCAD60KCB -59CN 230/50/1 Voltage Schematic

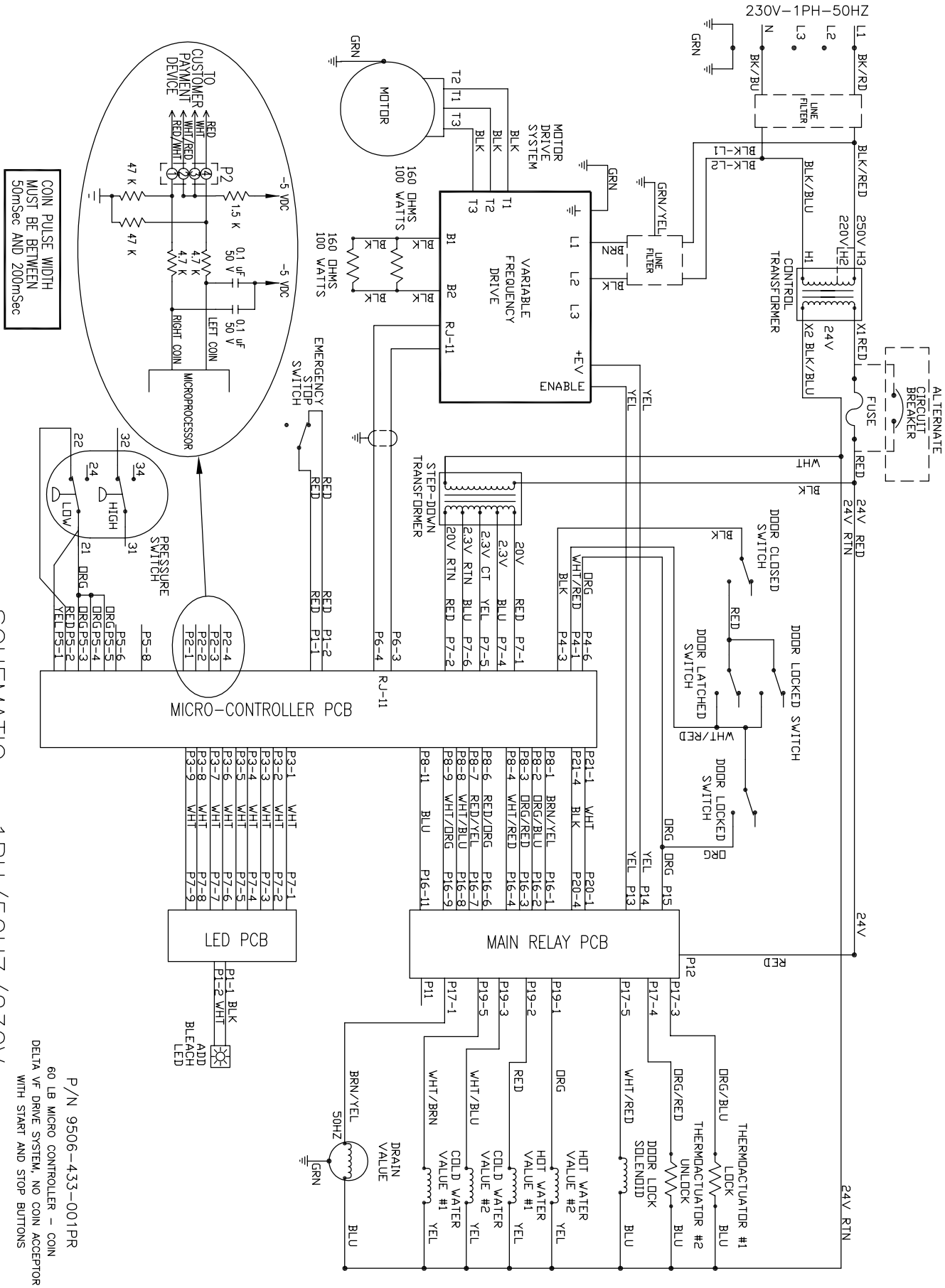

# WCAD60KCB -59CN 230/50/1 Voltage Diagram

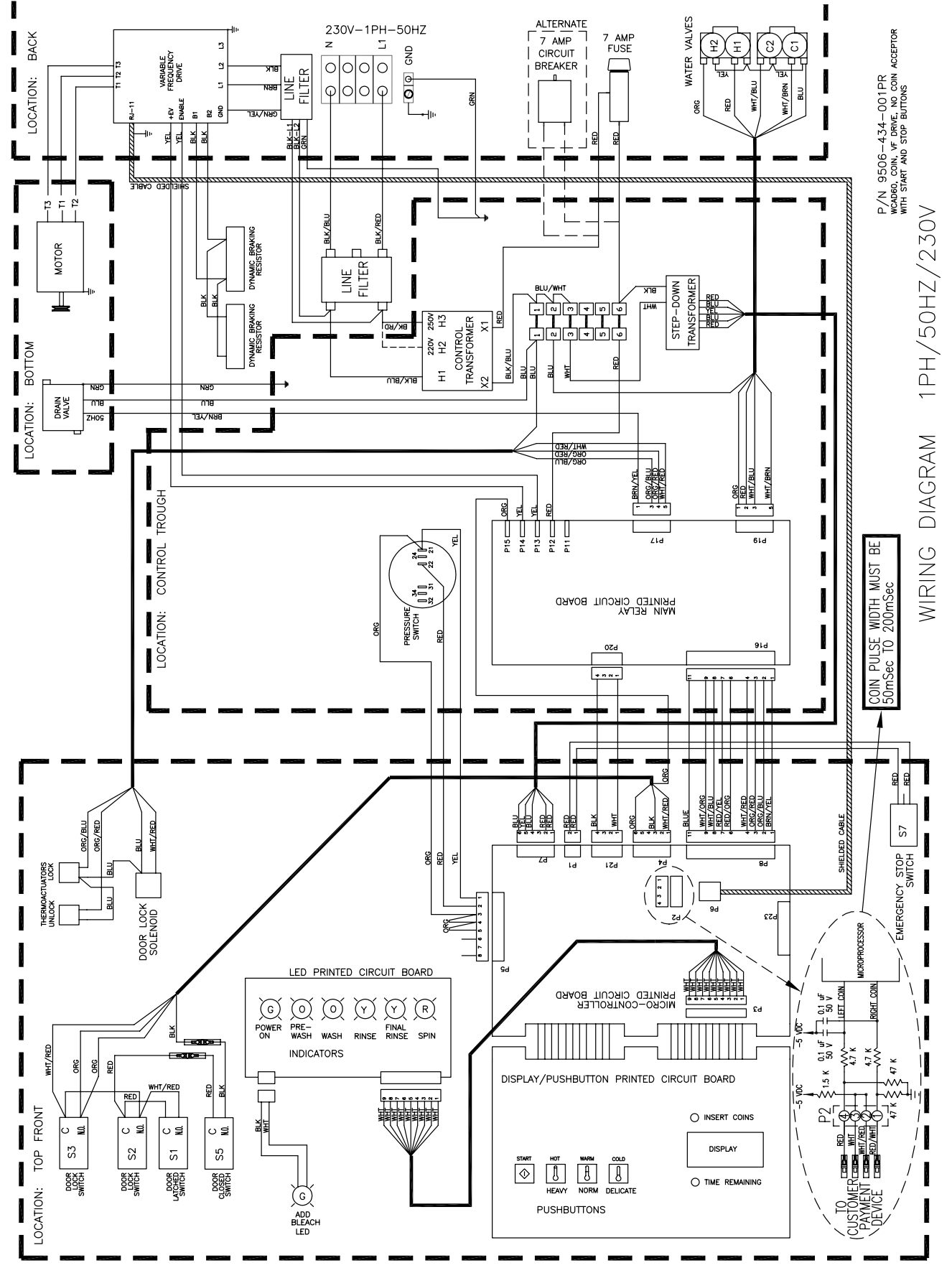

# WCAD60KCB -21CNSX 230/50/1 Voltage Schematic

230V-1PH-50HZ

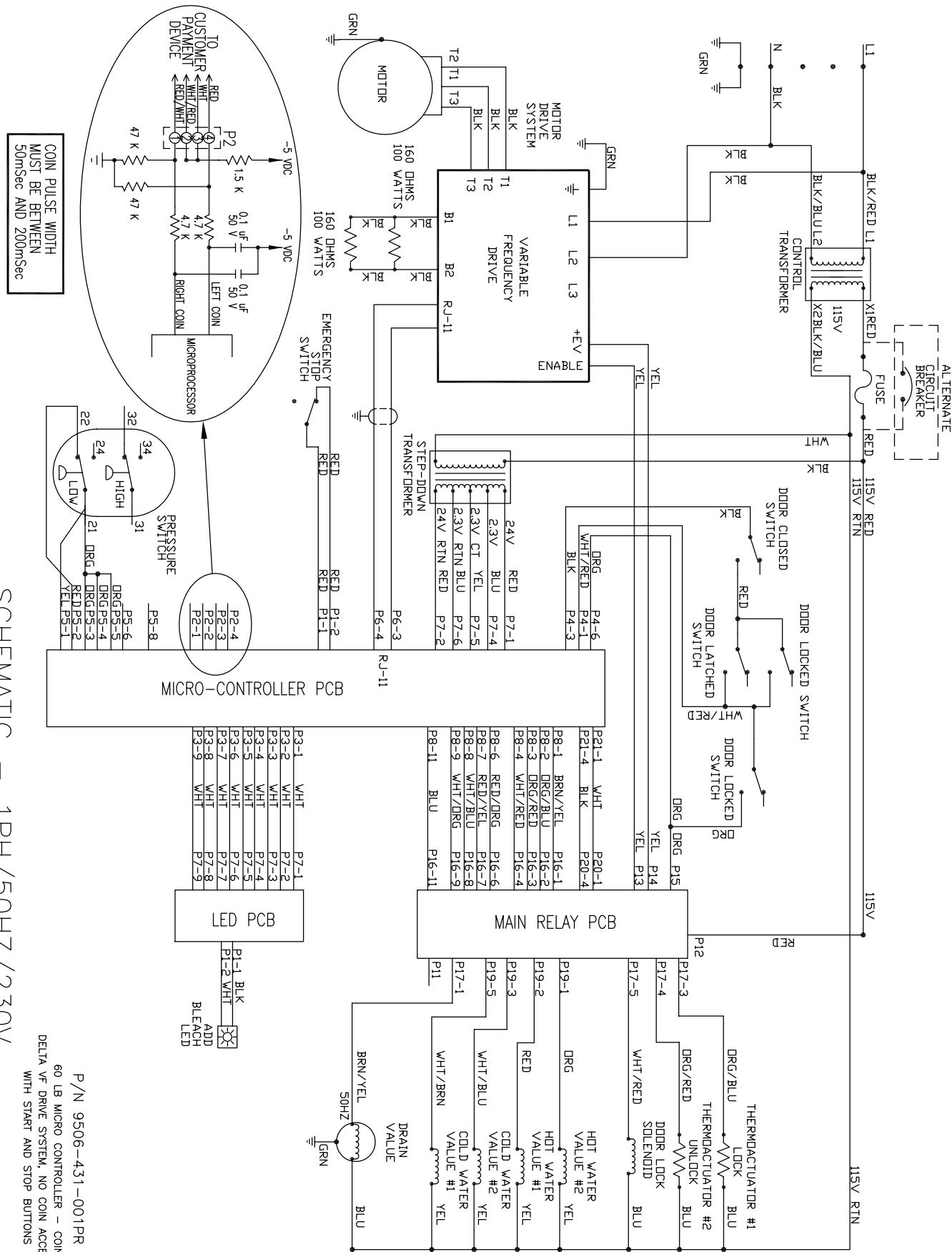

# WCAD60KCB -21CNSX 230/50/1 Voltage Diagram

230V-1PH-50HZ

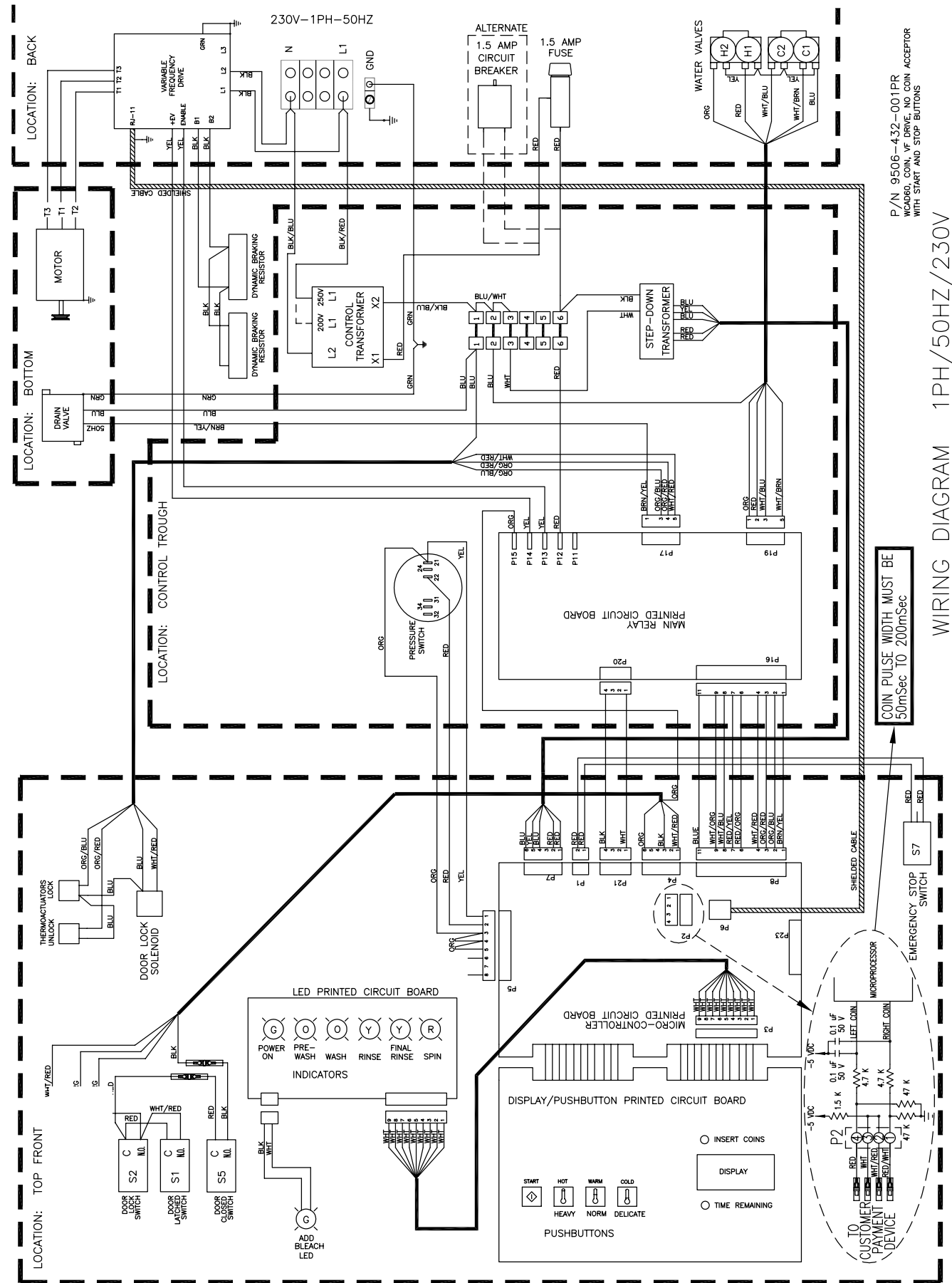



# WCAD80KCB -21CN 230/50/1 Voltage Schematic

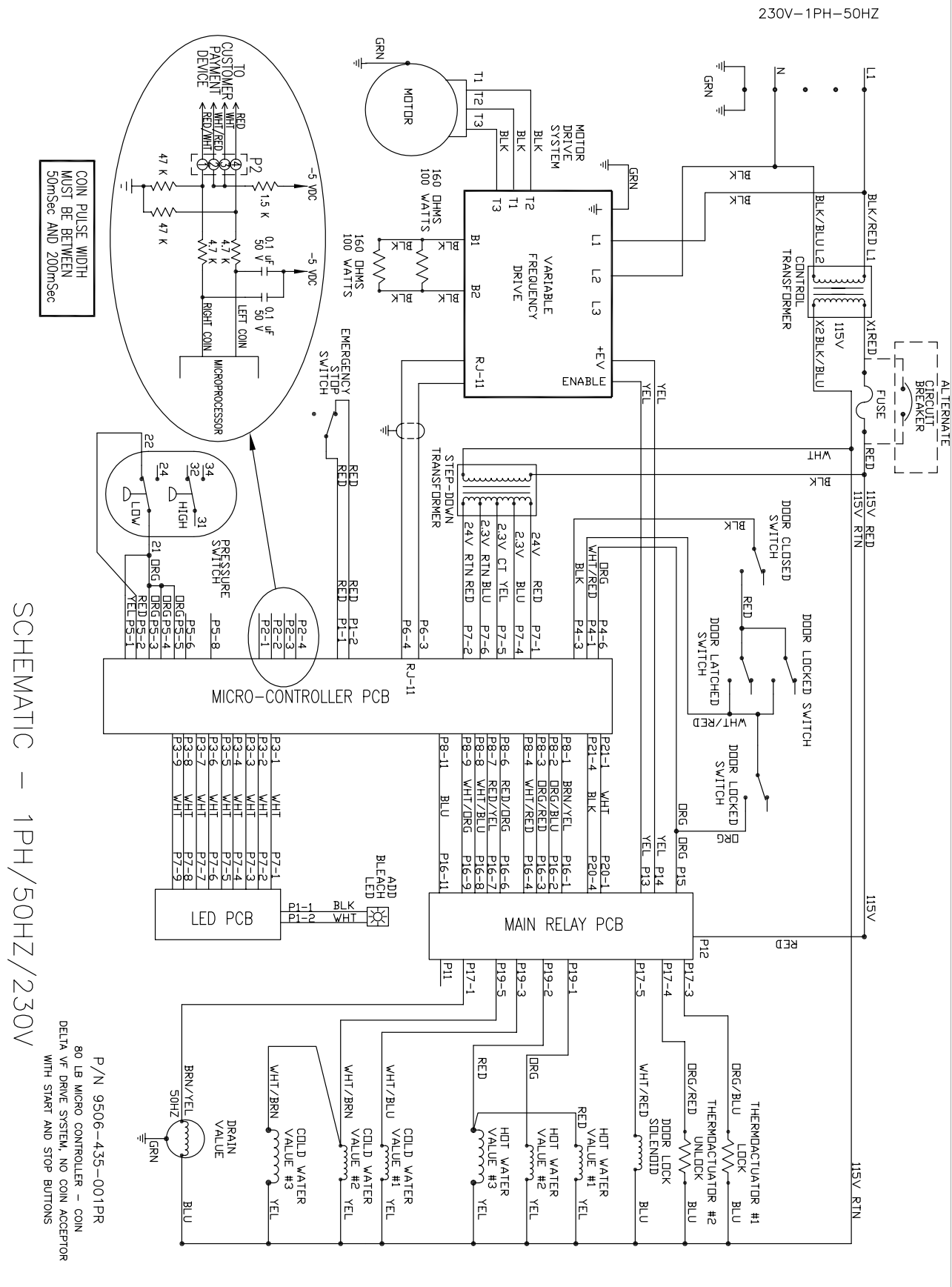

# WCAD80KCB -21CN 230/50/1 Voltage Diagram

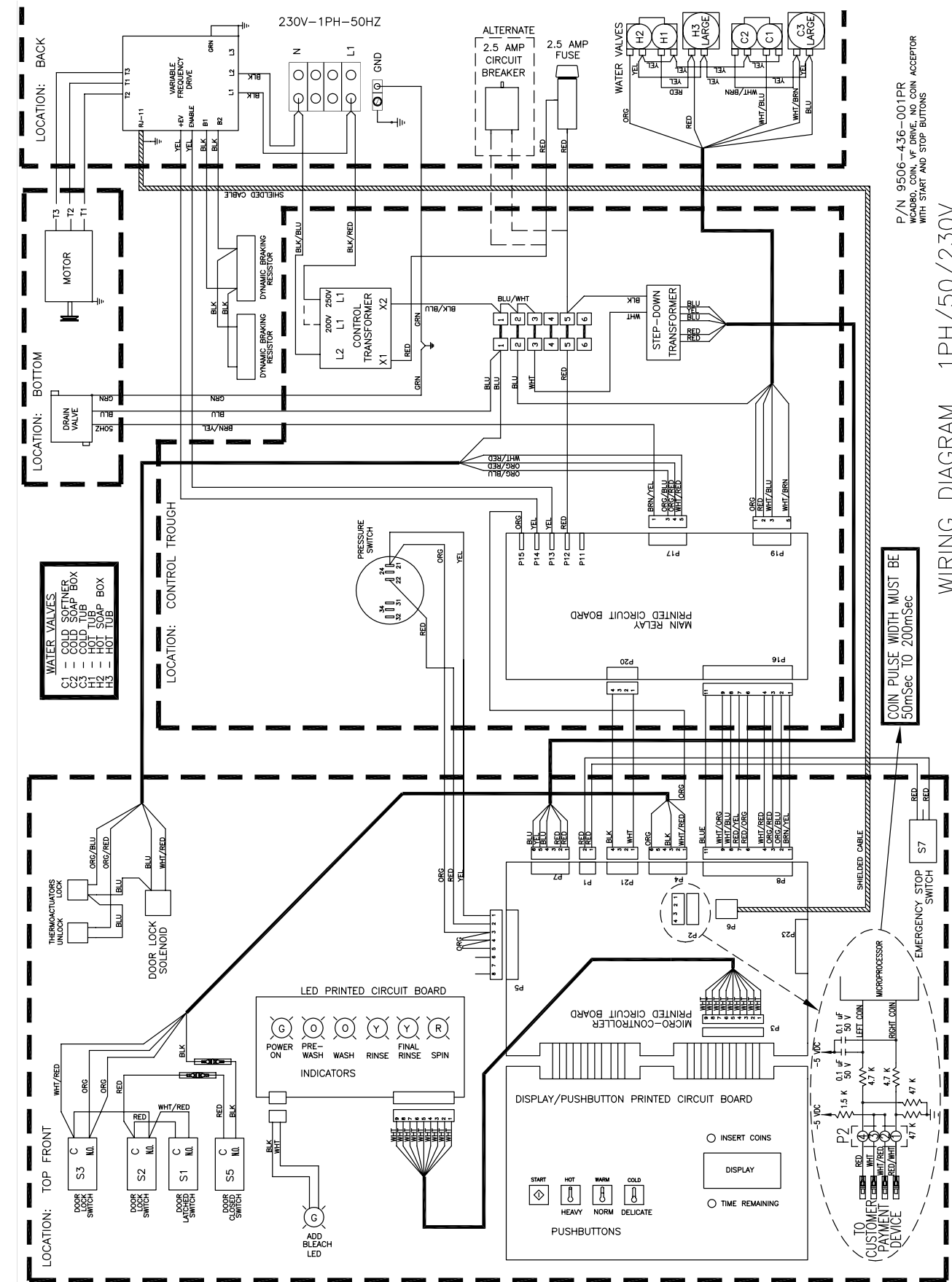

# WCAD80KCB -59CN 230/50/1 Voltage Schematic

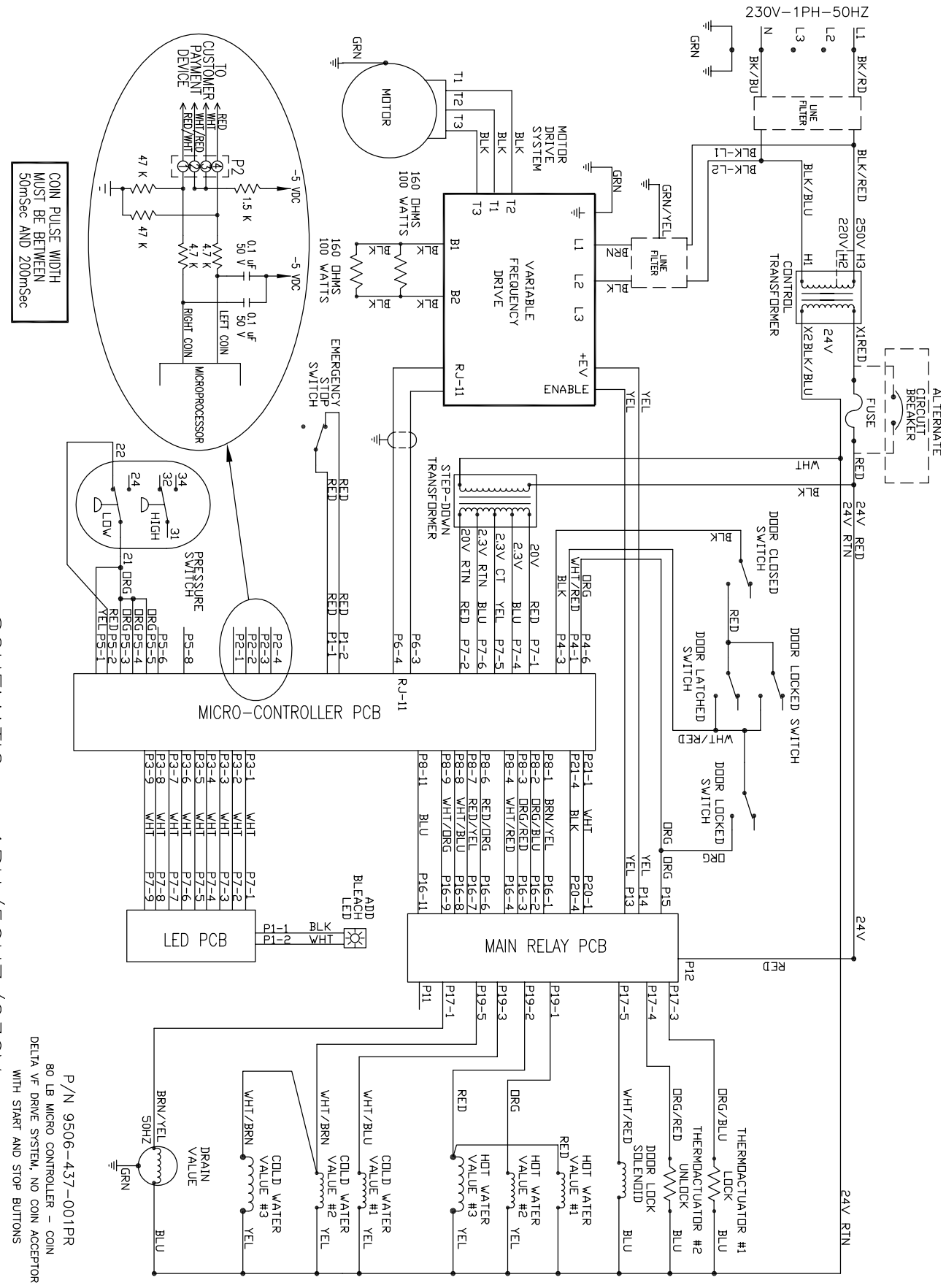

SCHEMATIC - 1PH/50HZ/230V

P/N 9506-437-001PR  
 80 LB MICRO CONTROLLER - COIN  
 DELTA VF DRIVE SYSTEM, NO COIN ACCEPTOR  
 WITH START AND STOP BUTTONS

# WCAD80KCB -59CN 230/50/1 Voltage Diagram

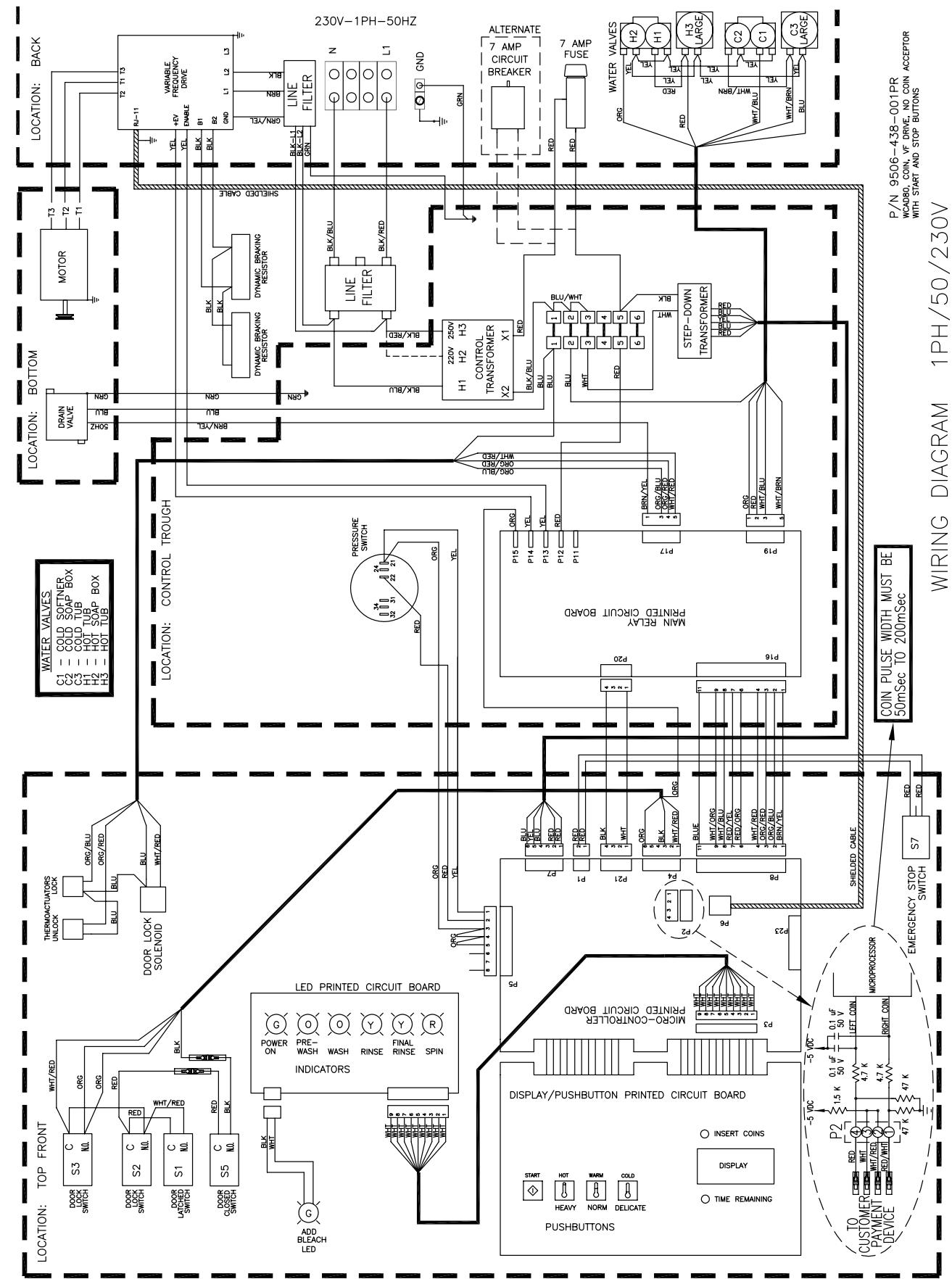

P/N 9506-438-001PR  
 WCAD80, COIN, VF DRIVE, NO COIN ACCEPTOR  
 WITH START AND STOP BUTTONS

WIRING DIAGRAM 1PH/50/230V

COIN PULSE WIDTH MUST BE  
 50mSec TO 200mSec



