



***DEXTER***<sup>®</sup>  
***LAUNDRY***

**USE THE BLUE TABS LOCATED ON THE  
RIGHT AND LEFT SIDES OF THE FOLLOWING  
DOCUMENT TO ADVANCE TO EACH SECTION.**











**DEXTER**  
LAUNDRY



N-Series On-Premise  
Mechanical Timer Dryer

DRH80

## Equipment Safety Warnings Symbols and Terminology Used in this Equipment

 <b>DANGER</b>	Indicates an imminently hazardous situation, which if not avoided, will result in death or serious injury.
 <b>WARNING</b>	Indicates a potentially hazardous situation, which if not avoided could result in death or serious injury.
 <b>CAUTION</b>	Indicates a potentially hazardous situation which, if not avoided, may result in minor or moderate injury. It may also be used to alert against unsafe practices. Minor burns, pinch points that result in bruises and minor chemical irritation.
<b>NOTICE</b>	Indicates information or a company policy that relates directly or indirectly to the safety of personnel or protection of property.
	This is the user caution symbol. It indicates a condition where damage to the equipment resulting in injury to the operator could occur if operational procedures are not followed. <b>TO REDUCE THE RISK OF DAMAGE OR INJURY</b> , refer to accompanying documents; follow all steps or procedures as instructed.
	This is the electrical hazard symbol. It indicates that there are <b>DANGEROUS HIGH VOLTAGES PRESENT</b> inside the enclosure of this product. <b>TO REDUCE THE RISK OF FIRE OR ELECTRIC SHOCK</b> , do not attempt to open the enclosure or gain access to areas where you are not instructed to do so. <b>REFER SERVICING TO QUALIFIED SERVICE PERSONEL ONLY</b>
	Caution! There are sharp edges on various sheet metal parts internal to the enclosure. Use safety consciousness when placing or moving your hands while working in the interior of this equipment.
	Caution! To reduce the risk of damage to the Water Inlet Valve, do not supply inlet water with a temperature that exceeds 70° C.
	Caution! To reduce the risk of fire or explosion, do not operate this equipment in any hazardous classified (ATEX) environment.

## Equipment Safety Warnings Symbols and Terminology Used in this Equipment



Warning! Do not operate equipment if door glass is damaged in any way.



Warning! Keep clear of rotating parts.



Prohibited! Do not enter this equipment or space.



Prohibited! Do not step or stand on this equipment.

Prohibited! Do not operate without all guards and covers in place.



Prohibited! Do not operate without all guards and covers in place.



Prohibited! Do not wash or Dry clothing impregnated with flammable liquids (petrochemical).



Prohibited! Do not allow children to play in or around equipment.

<b>DANGER</b>	Indicates an imminently hazardous situation, which if not avoided, <b>will result</b> in death or serious injury.
<b>WARNING</b>	Indicates a potentially hazardous situation, which if not avoided <b>could result</b> in death or serious injury.
<b>CAUTION</b>	Indicates a potentially hazardous situation which, if not avoided, <b>may result</b> in minor or moderate injury. It may also be used to alert against unsafe practices. Minor burns, pinch points that result in bruises and minor chemical irritation.
<b>NOTICE</b>	Indicates information or a company policy that relates directly or indirectly to the safety of personnel or protection of property.
<b>!</b>	This is the user caution symbol. It indicates a condition where damage to the equipment resulting in injury to the operator could occur if operational procedures are not followed. <b>TO REDUCE THE RISK OF DAMAGE OR INJURY, refer to accompanying documents; follow all steps or procedures as instructed.</b>
<b>⚡</b>	This is the electrical hazard symbol. It indicates that there are <b>DANGEROUS HIGH VOLTAGES PRESENT</b> inside the enclosure of this product. <b>TO REDUCE THE RISK OF FIRE OR ELECTRIC SHOCK, do not attempt to open the enclosure or gain access to areas where you are not instructed to do so. REFER SERVICING TO QUALIFIED SERVICE PERSONEL ONLY</b>
<b>EX</b>	Caution! To reduce the risk of fire or explosion, do not operate this equipment in any hazardous classified (ATEX) environment.



## WARNING



- All Dryers must be installed in accordance to all applicable electrical, plumbing and all other local codes.
- These installation and operation instructions are for use by qualified personnel only. To avoid injury and electrical shock, do not perform any servicing other than that contained in the installation and operation instructions, unless qualified.



Do not install Equipment in an explosive atmosphere.



- Care must be stressed with all foundation work to ensure a stable unit installation, eliminating possibilities of excessive vibration.
- Foundation must be level within 13 mm to ensure proper washer operation.



Do not operate washer or Dryer if door glass is damaged in any way.



Do not wash or Dry clothing impregnated with flammable liquids (petrochemical).



## WARNING



Children should be supervised to ensure they do not operate or play in or around equipment.









Keep all panels in place to protect against electrical shock and injury and add rigidity to washer.

This appliance is not intended for use by persons (including children) with reduced physical, sensory or mental capabilities, or lack of experience and knowledge, unless they have been given supervision or instruction concerning use of the appliance by a person responsible for their safety.

A washer should not be allowed to operate if any of the following occur:

- Excessive high water level.
- Machine is not connected to a properly earthed circuit.
- Door does not remain securely locked during the entire cycle.
- Vibration or shaking from an inadequate mounting or foundation

	<b>Warning! Do not operate equipment if door glass is damaged in any way.</b>
	<b>Warning! Keep clear of rotating parts.</b>
	<b>Prohibited! Do not enter this equipment or space.</b>
	<b>Prohibited! Do not step or stand on this equipment.</b>
	<b>Prohibited! Do not operate without all guards and covers in place.</b>
	<b>Prohibited! Do not operate without all guards and covers in place.</b>
	<b>Prohibited! Do not wash or Dry clothing impregnated with flammable liquids (petrochemical).</b>
	<b>Prohibited! Do not allow children to play in or around equipment.</b>

	<b>Prohibited! Do not attempt to open, touch, or proceed before referring to the manual or unless qualified.</b>
	<b>Mandatory! Read all supporting documentation before operating or maintaining equipment.</b>
	<b>Mandatory! Disconnect power before servicing equipment.</b>
	<b>Mandatory! Lock out and tag out before servicing this equipment.</b>
	<b>Mandatory! Children should be supervised to ensure they do not operate equipment.</b>
	<b>Mandatory! Children should be supervised to ensure they do not operate equipment.</b>





---

# Section 1:

## Machine Mounting

---

## Specifications for below model is outlined in this book:

Model	DRH80 Manual timer controlled Industrial dryer
Capacity Maximum	80 pounds dry weight
Cylinder dimensions	36½" diameter, 38" depth
Cabinet dimensions	38.44"W x 51.13"D x 75.13"H.(w/legs)
Drive motor	Drive motor - 1 HP.
Construction	Standard trunnion style cylinder support
Air flow	1200 CFM total air flow Fully perforated tumbler for cross flow air circulation
BTU rating	215,000 BTU input Natural gas standard, LP kits available separately
Ignition	Direct spark electronic ignition
Exhaust	One 8" connection
Gas line connection	½" N.P.T.
Electrical	120/208-240 Volts, 60 HZ AC,1 Ph. 15 amp circuit breaker or equivalent. Running amps 60 hz/Phase 10.8/120V/1 5.2/208-240V/1 Running amps 50 hz/Phase 6.4 220-240/1
Manually operated	Dual timers - Dry time & Cool down time
Temperature Control	Mechanical thermostat
Weight (shipping lbs./ net lbs.)	693/613
Service	2 wires + ground
Colors	White, Stainless Steel

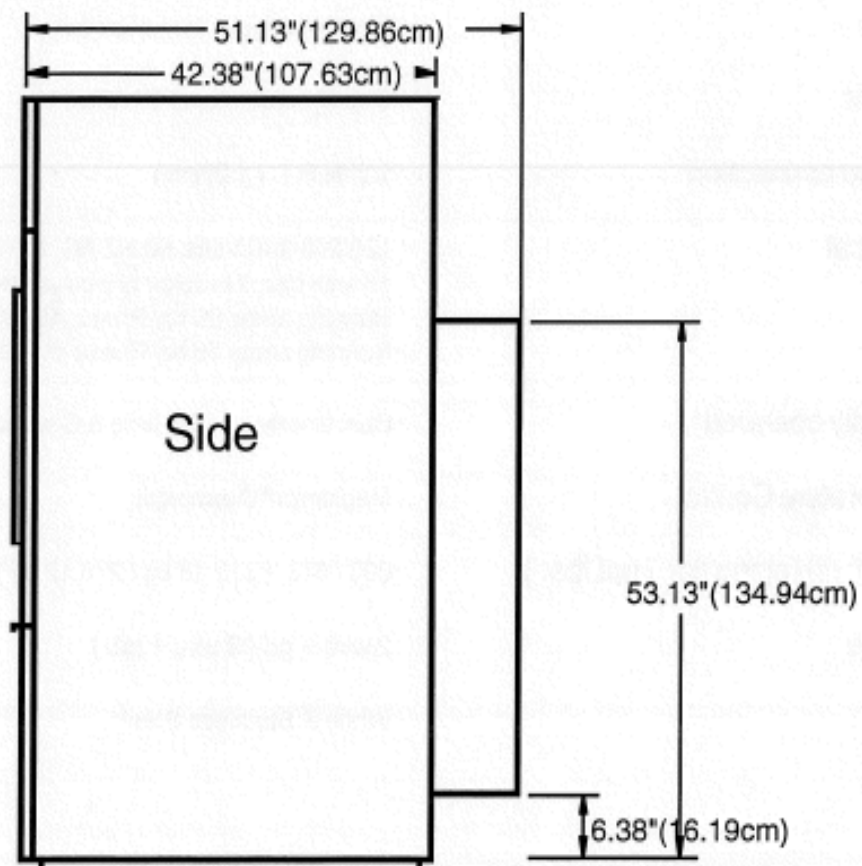
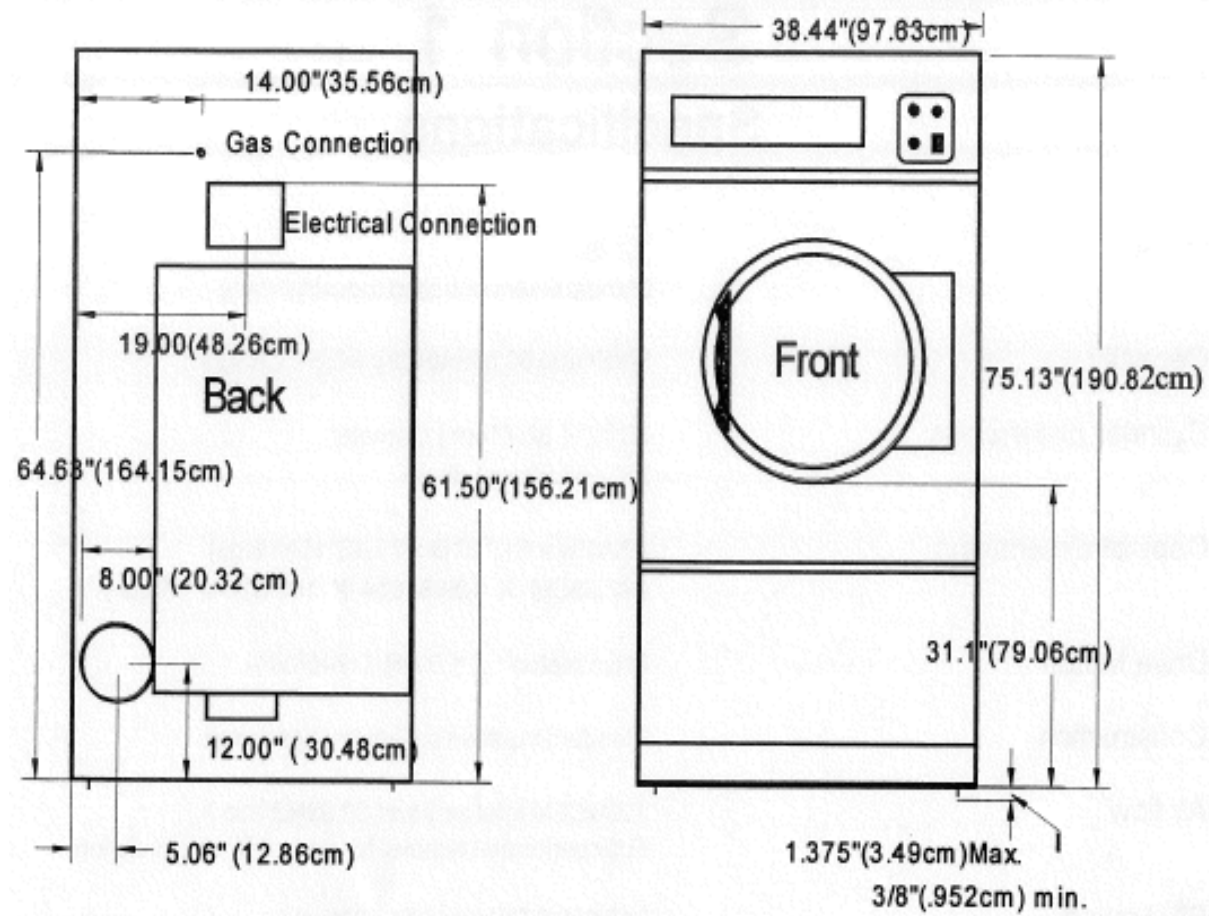

## Section 2:

### Machine Installation & Operating Instructions

## Installation & Operation

### Uncrating

1. Remove cardboard and innerpack.

### Installation

1. All commercial dryer installations must conform with local applicable local codes or in the absence of local codes, with the National Fuel Gas Code ANSI ,2223.1A-1988. Canadian installations must comply with current standard CAN/CGA-Bi 49(.1 or .2) Installation Code for Gas Burning Appliances or Equipment, and local codes if applicable. The appliance, when installed, must be electrically grounded in accordance with the National Electric Code, ANSI/NFPA No. 70-1 990, or when installed in Canada, with Standard CSA C22.1 Canadian Electrical Code Part 1.
2. Installation clearances: This unit may be installed at the following alcove clearances.
  1. Left side 0"\*
  2. Right side 0"\*\*Units may be installed in direct contact with an adjacent dryer, providing allowance is made for opening upper & lower service doors.
3. Back 18" (certified for 1" clearance; however 18" behind the guard is recommended to clean, service & maintain the dryer)
4. Front 48" to allow use of dryer.
5. Top Certification allows 0" clearance at the top from the front back 1". However, a 1/2" clearance is required to allow opening the upper service door. A 4" clearance is required at the top between 1" & 4" from the front. A 10" clearance is required from the top at all other points.
6. Floor This unit may be installed upon a combustible floor.

**Make-up Air.** Adequate make-up air must be supplied to replace air exhausted by dryers on all types of installations. Provide a minimum of 1 square foot of make-up air opening to the outside for each dryer. This is a net requirement of effective area Screens, grills or louvers which will restrict the flow of air must be considered. Consult the supplier to determine the free area equivalent for the grill being used.

The source of make-up air should be located sufficiently away from the dryers to allow an even air flow to the air intakes of all dryers. Multiple openings should be provided.

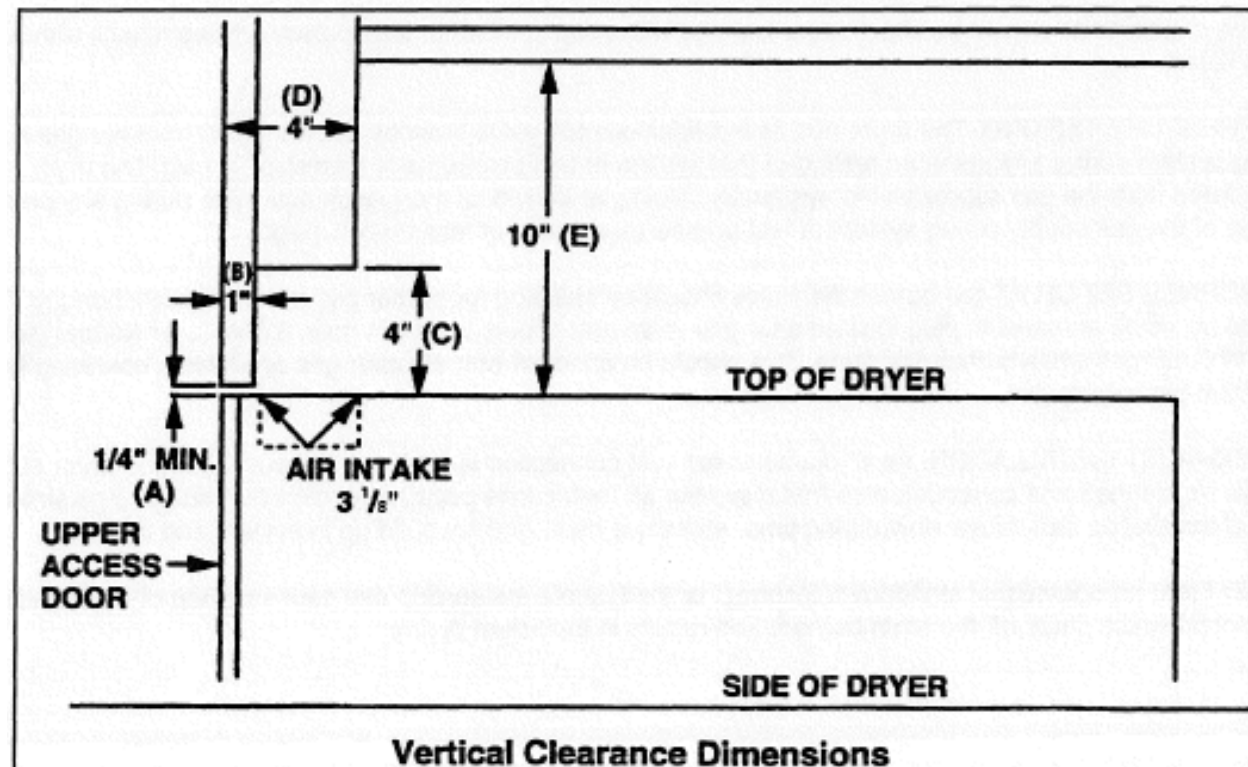

**NOTE:** The following considerations must be observed for gas dryer installations where dry cleaners are installed. The sources of all make-up air and room ventilation air movement to all dryers must be located away from any dry cleaners. This is necessary so that solvent vapors will not be drawn into the dryer inlet ducts. Dry cleaner solvent vapors will decompose in contact with an open flame such as the gas flame present in clothes dryers. The decomposition products are highly corrosive and will cause damage to the dryer ducts and clothes loads.

**Electrical requirements.** The electrical requirements necessary to operate the unit satisfactorily are listed on the serial plate located on the back panel of each dryer. The electrical connection should be made to the control box on the rear of the unit, using #12 AWG wire or larger.

ONE 15 Amp circuit breaker is required. The wiring diagram is located on the belt guard on the back of the dryer.

**NOTE:** THE DRYER MUST BE GROUNDED BY A SEPARATE GROUND CONDUCTOR FROM THE GROUND SCREW ON THE DRYER TO THE NEUTRAL BAR IN THE SUPPLY BREAKER BOX.

**Gas requirements.** The complete gas requirements necessary to operate the dryer satisfactorily are listed on the serial plate located on the back panel of the dryer. The inlet gas connection to the unit is 1A inch pipe thread. However, the size of the piping to supply the dryer should be determined by reference to the Fuel Gas Code and consulting the local gas supplier.

A joint compound resistant to the action of liquefied petroleum gases should be employed in making pipe connections. A 1/4 inch NPT plugged tapping, accessible for test gage connection, must be installed immediately upstream of the gas supply connection to the dryer.

A drip tee should be provided in the gas piping supplying the unit to catch dirt and other foreign articles.

All pipe connections should be checked for leakage with soap solution or leak detector. Never check with an open flame.

**PRESSURE TESTING.** The dryer and its individual shutoff valve must be disconnected from the gas supply piping system during any pressure testing of that system at test pressures in excess of 1/2 psig. The dryer must be isolated from the gas supply piping system by closing its individual manual shutoff valve during any pressure testing of the gas supply piping system at test pressures equal to or less than 1/2 psig.

**BURNER SET-UP.** All gas burner manifolds should be checked for proper gas pressure while burning. Check should be made at manifold plug located after gas valve and should be set at max. 3.5 W.C. for Natural gas or 11.5 W.C. LP gas while burner operating. This should be checked with all other gas appliances operating from this main gas supply line.

**EXHAUST INSTALLATION.** An 8" diameter exhaust connection is required. Exhausting of the dryer should always be planned and constructed so that minimum air restrictions occur. Any restriction due to pipe size or type of installation can cause slow drying time, excessive heat, and lint build up in system and the room. **NOTE:** From an operational standpoint, incorrect or inadequate exhausting can cause cycling of the high limit thermostat which shuts off the main burners and results in inefficient drying.

Individual exhausting of the dryer is recommended. All heat, moisture, and lint should be exhausted outside by attaching a pipe of the proper diameter to the outside by attaching a pipe of the proper diameter to the dryer adapter collars and extending it out through an outside wall. This pipe must be very smooth on the inside, as rough surfaces tend to collect lint which will eventually clog the ducts and prevent the dryer from exhausting properly. All elbows must be smooth on the inside. All joints must be made so the exhaust end of one pipe is inside the next one downstream. The addition of an exhaust pipe tends to reduce the amount of air the blower can exhaust. This does not affect the dryer operation if held within practical limits. For the most efficient operation, it is recommended that no more than 20 feet of straight 8" diameter pipe with two right angle elbows be used for each cylinder. When more than two elbows are used, two feet of straight pipe should be removed for each additional elbow. No more than four right angle elbows should be used to exhaust each cylinder.

If the exhaust pipe passes through a wall, a metal sleeve of slightly larger diameter should be set in the wall and the exhaust pipe passed through this sleeve. This practice is required by some local codes and is recommended in all cases to protect the wall. This type of installation should have a means provided to prevent rain and high winds from entering the exhaust when the dryer is not in use. A hood with a hinged damper can be used for this purpose. Another method would be to point the outlet end of the pipe downward to prevent entrance of wind and rain. In either case, the outlet should be kept clear by at least 24" of any objects which would cause air restrictions.

Never install a protective screen over the exhaust outlet.

When exhausting a dryer straight up through a roof, the overall length of the duct has the same limits as exhausting through a wall. A rain cap must be placed on top of the exhaust and must be of such a type as to be free from clogging. The type using a cone shaped "roof" over the pipe is suitable for this application.

Exhausting the dryer into a chimney or under a building is not permitted. In either case there is a danger of lint build-up which can be highly combustible.

Installation of several dryers where a main discharge duct is necessary, will need the following considerations for installation. Entrance into the main discharge duct should be at a 45 degree angle in the direction of discharge airflow.

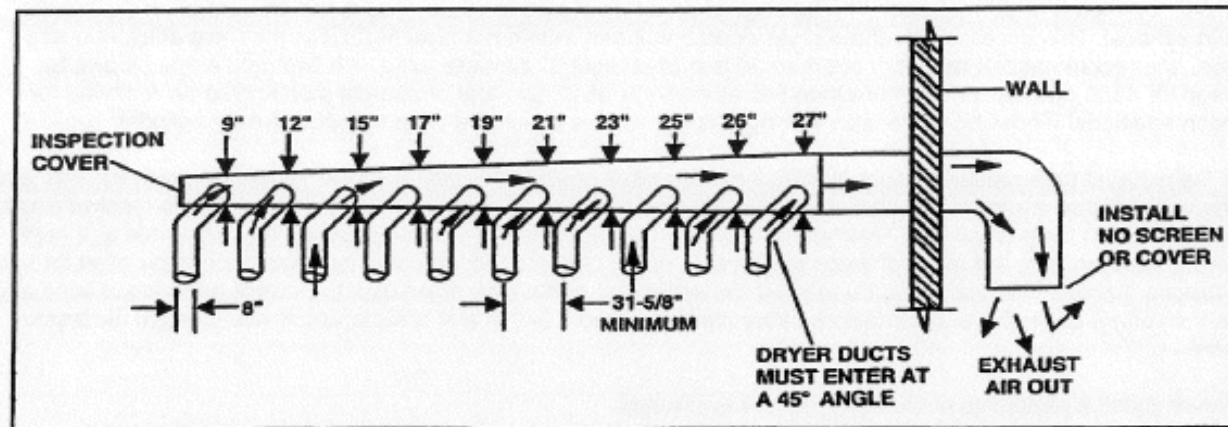

NOTE: Never install the 8" ducts at a right angle into the main discharge duct. The following illustration shows the various round main duct diameters to use with the individual dryer ducts. The main duct can be rectangular or round, provided adequate air flow is maintained. For each dryer the total exhausting (main discharge duct plus duct outlet from the dryer) should not exceed the equivalent of 20 feet and two elbows. The diameter of the main discharge duct at the last dryer must be maintained to exhaust end.

NOTE: A small diameter duct will restrict air flow, a large diameter duct will reduce air velocity, both contributing to lint build up. An inspection door should be provided for periodic clean-out of the main duct.

#### DRYER SHUTDOWN-

To render the dryer inoperative turn off the main gas shut-off valve and disconnect power to the dryer.

#### Electrical Connections

##### 240 Volts, 60 Hertz, 1 Phase, 2 Wire Plus Ground

This machine was factory wired and tested at this voltage. If hookup to another voltage is required, refer to wiring diagram, schematic and the instructions below.

##### 208 Volts, 60 Hertz, 1 Phase, 2 wire Plus Ground

For connection to a 208 volt, 60 hertz, 1 phase supply, move the wire on the control transformer from the 240 volt terminal to the 208 volt terminal.

##### 120 Volts, 60 Hertz, 1 Phase, 2 Wire Plus Ground

For connection to a 120 volt, 60 hertz, 1 phase supply, move the wire on the control transformer from the 240 volt terminal to the 120 volt terminal. Move the number 3 end of the black jumper wire connecting terminal 3 and 4 on the terminal block so it now connects terminals 2 and 4. Move the number 5 end of the black jumper wire connecting terminals 5 and 6 on there terminal block so it now connects terminals 3 and 6.

FUSING	120V	20 Amp circuit breaker or time delay fuse is required.
	240V	15 Amp circuit breaker or time delay fuse is required.

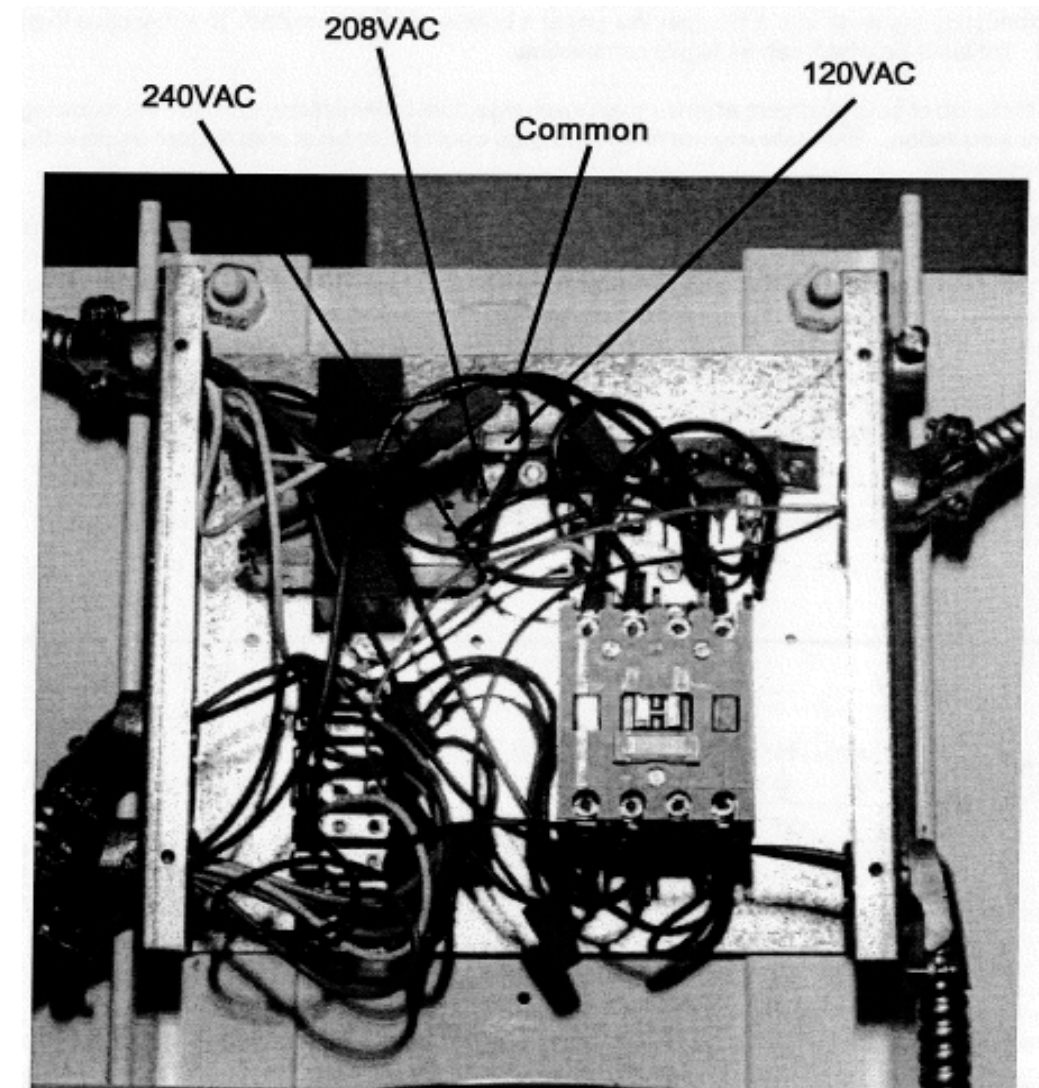

---

## Dryer Controls

### Dry Time Timer

The dry time timer sets the drying time only and does not include the cool-down time. However, for safety there is an automatic cool down of 2 minutes minimum built into the cycle even when none is called for by the cool down timer.

### Cool Down Timer

The cool down timer sets the cool down time for the cycle. This time is added to the time placed on the main cycle timer.

### Adjustable Thermostat

The thermostat knob allows you to set the desired temperature range for the particular load being dried.

### Push to Start Switch

The push-to-start switch must always be pushed to start a stopped tumbler. (At least one of the timers must have time placed on it and the loading door must be closed for tumbler motion to occur).

### On Light

The ON light is built in to the push-to-start button. It indicates that time has been added to at least one of the timers.

## Operating Instructions

1. Load clothes into the tumbler and close the door. The clothes should be well separated. Untangling following washing may be necessary for best drying.
2. Set the temperature selector to the desired setting for the type of clothes to be dried.

LOAD	TEMPERATURE
Delicate	Warm
Perma-Press/Personal	Medium
100% Cottons	Hot

3. Set the drying timer for the time estimated to dry the load of clothing,
4. Set the cool-down timer for the desired cool-down time.
5. Press the start switch and hold momentarily until dryer reaches operating speed.

**IMPORTANT:** Normally, dryer operation will continue uninterrupted through the complete cycle determined by number of minutes set on timer. However, opening the loading door will interrupt the circuits and the drive motor and main burners will cease to function. The signal light will remain on and the time cycle will continue independent of the interruption until expiration of the time on the timers or until drying cycle is resumed by closing the door and restarting the dryer to continue drying the clothes. Either the drying timer or the cool-down timer may be canceled at any time by turning the knob counterclockwise to "off".

Characteristics of running dryer:

Temperature selection may be changed at any time with the dryer running. Running time may be extended any time that while the dryer is running if desired.

---

# Section 3:

## Electrical Wiring Diagrams & Schematics



---

# Section 4:

## Machine Service Procedures

---

### Clothes Door Removal

1. The clothes door may be removed from the hinge bracket by unscrewing and removing the alien head pivot screw located at the door upper hinge point.
2. Next lean the door out of the top of the hinge bracket and lift the door from the bottom hinge pin.

### Clothes Door Latch Adjustment

1. Loosen the lock nut on the latching stud. It is located directly behind the door handle.
2. Open the loading door.
3. Screw the door catch stud in or out as necessary and then retighten the lock nut.

### Installation of Clothes Door Window & Gasket

1. Remove the loading door.
2. Place the clothes door, with its face down, on a solid surface.

Note: Prewarming the gasket under a heat lamp makes the installation much easier.

3. Put the door glass gasket on the loading door with the ridges in the wide side up. Locate the seam at the door latching stud.

NOTE: The gasket has one narrow opening on one side and a wide opening on the other. The narrow side mounts to the door: The wide side holds the glass. The wide side has ridges on one interior lip. This ridged side should go up with the door laying face down.

4. Coat the inside and outside of the gasket with rubber lubricant or liquid soap.
5. Slide the glass into the middle of the gasket with half of the glass above the door and half below the door.
6. While pressing on the glass, use a modified screwdriver (grind the end off so that it is round and put a slight bend in it) and run it around half of the glass.
7. With half of the glass installed, turn the door over and repeat step 6.
8. Insert the modified screwdriver at the 6 o'clock position and pry the glass up enough to install the door glass support spacer (small diameter rubber tube).

---

## Door Switch Removal & Installation

1. The door switch is located directly behind the hinge plate of the loading door assembly. Open the door for access to the switch area. Remove the two screws holding the switch box cover in position. This will allow the removal of the cover and the switch actuator plate.
2. The entire switch box can now be pulled from the front panel opening, creating access to the door switch mounting screws.
3. Remove these two mounting screws and twin nut which frees the door switch and insulating shield. Remove wires.
4. When installing the door switch make certain the insulating shield is reassembled.
5. The actuator plate and switch box cover should be assembled as illustrated in the parts section of the book.

## Door Switch Operation & Testing

1. The normally open door switch must be closed (0 ohms resistance) for the motor and heat circuits to operate. When the door is opened, the door switch breaks the 120 volt control circuit.

## Door Switch Adjustment

1. Remove the two switch box cover screws.
2. Remove the switch cover and actuator plate.
3. Pull the entire switch box out from the opening in the front panel.
4. Loosen the bottom door switch mounting screw.
5. A slotted mounting allows the switch to slide in or out for adjustment.

## High Limit Thermostat Locations & Functions

- A. Burner Housing- This hi-limit is located on the left side of the burner housing.
1. The thermostat opens the circuit to the main burners in the event of malfunction in the gas control area or temperature control. This thermostat will open quickly if there is a significant loss of air flow over the burner area.
  2. It is covered by a guard and is held in place by two screws. There are spacers between the thermostat and bracket which must be used to give proper operation.
- B. Over temperature Safety Thermostat- The second hi-limit thermostat is located at the rear of the machine, bottom exhaust outlet.
1. The manually resettable thermostat limits the operating temperature a dryer can reach should some abnormal situation occur.
  2. Should the thermostat be tripped, the dryer will cease to heat until the thermostat is reset. Once the dryer cools, the thermostat may be reset by inserting a pencil or stick through the opening in the thermostat cover and pushing the button in.

---

## Pressure Regulator Adjustment

Use the following procedure whenever it is necessary to check the pressure regulator setting.

NOTE: Any adjustment of the pressure regulator must be made with a manometer attached at the plug in the main burner manifold.

1. Shut off the gas supply to the dryer.
2. Remove the ¼" pipe plug from the end of the main burner manifold.
3. Attach a manometer to the manifold end.
4. Remove the pressure regulator cover screw on the gas valve.
5. Open the shut-off valve, and operate the dryer.
6. Adjust the pressure for a manometer reading of 3.5" water column gas pressure. (11.0" for LP.)

NOTE: The main burners must be operating when adjusting the pressure regulator.

7. Shut off the gas supply to the dryer. Remove the manometer and install the ¼" pipe plug in the manifold.
8. Open the shut off valve, start the dryer and check for gas leaks while the burners are ignited.

## Dry Timer & Cool Down Timer Removal

The two control timers are located inside the upper service door on the right side in the control area. The thermostat knob must be removed in order to swing out the control panel. The timer knobs must also be removed if the timers are to be removed. There are two nuts mounting each timer.

## Thermostat Removal & Testing

The control thermostat is located inside the upper service door on the right side in the control area. The thermostat knob must be removed in order to swing out the control panel. The control thermostat is mounted to the mounting bracket by two screws.

The thermostat is normally closed at room temperature when the machine is cold.

The machine should measure a high temperature of approximately 190 degrees at the exhaust outlet.

## Push to Start Switch Removal

The push-to-start switch can be removed by compressing the plastic locking tabs on both ends of the switch and removing from the back of the control panel.

## Front Panel Removal

To remove the front panel, first remove the loading door from the panel. Then remove the two left side screws and the four right side screws. The trim does not have to be removed. The panel may be removed with the door left in place, although it is much heavier and more awkward to do so.)

NOTE: Always remove power from the machine before changing drive belts or working with the drive and fan system.

## Final Drive Belt Replacement

To replace the final drive belt turn the cylinder slowly by hand and work the belt off of the large pulley.

## Motor Drive Belt Replacement

To replace the motor drive belt the final drive belt should be removed as above. Next turn the intermediate drive pulley and work the belt off of it similarly to the above belt.

## Blower Impeller Removal

Remove motor support assembly with motor and impeller cover, to access the impeller. Mark shaft location and remove 2 set screws that hold the motor to the shaft.

## Air Switch Removal & Adjustment

The air switch assembly is part of the ignition safety circuit and insures that the burners don't operate unless there is air flow. If this doesn't happen ignition will not occur. The air switch assembly is mounted on the rear back panel.

## Electronic Ignition Module

This machine uses an electronic spark ignition system to directly light the burners.

1. The electronic ignition module (gray box) is located inside the upper access door in the control box.
2. The red wire from the transformer, thru the 1.5 amp fuse and into the module supplies the 24 volts required to operate the entire direct ignition system.
3. The black colored hi-voltage wire (spark plug type) plugs onto the post connector on the module, and the multi-wire plug fits into the side of the module.

## Spark Electrode Assembly-Function

1. The spark electrode and sensing electrodes are located directly over the left burner inside the burner housing.
- 2.

The electrode with conducts the spark to the gap between these two areas should be  $\frac{1}{4}$ ". The distance from the electrode to the burner assembly should be  $\frac{3}{8}$ "

3. The electrode with the black sensing wire detects ignition and monitors flame by signaling the module.

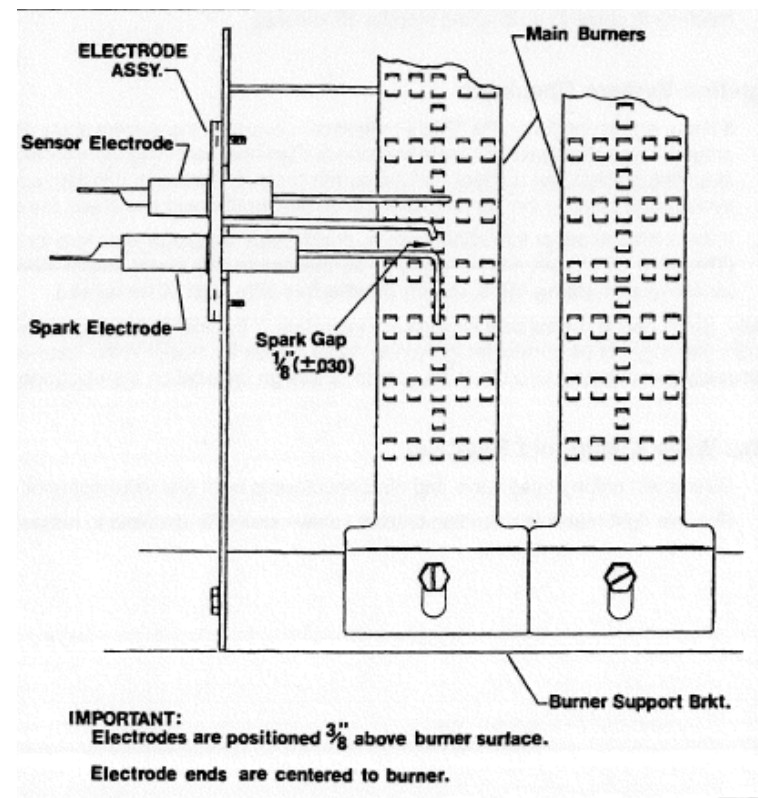

## Spark Electrode Assembly-Removal

1. Remove electrode cover and disconnect wires to electrodes.
2. Remove two screws to detach electrode assembly.

NOTE: Proper grounding of the ignition system (yellow wires) is very critical for proper ignition sequence.

## Ignition System-Function & Sequence

During normal dryer operation, the following occurs:

1. The dryer thermostat calls for heat.
2. If the drive motor is running, the motor safety circuit provides power to the hi-limit thermostat, air damper switch, and cycling thermostat in that order. If the thermostat senses that the temperature is low enough to require the heat should be on a circuit is closed allowing power to the ignition module (gray box). After approximately 10 seconds of purge time power is applied to open the gas valve and at the same time sparking occurs at the ignition electrode.
3. Once the flame is established, the sensing electrode detects the presence of flame and the sparking stops.
4. If for any reason the flame is not established in a period of 10 seconds, the gray box shuts down the sparking and closes the gas valve which is now in "Safety Lock-Out". Normally the 10 seconds "Trial For Ignition" period is more than ample to establish and prove flame.
5. If the flame is shut down or blown out during operation, the igniter will immediately go into "Trial For Ignition" again for 10 seconds.
6. However, if during any 10 second "Trial for Ignition", the flame is not established, the ignition system goes into "Safety Lock-Out" and will not reactivate the "Trial for Ignition" until there is a current interruption for a period of 15 seconds. This interruption can be provided by opening the dryer loading door and allowing the machine to come to a complete stop for 15 seconds.

## Ignition System Checkout

1. If flame is present during the "Trial For Ignition" period but the system shuts down, there may be an improper ground. The entire ignition system is grounded together including the electrode assembly, the electrode mounting bracket, the burners and the burner bracket. Shutdown can also occur if for some reason the system isn't sensing the flame. Check the sensor for damage and check the connections of the sensor lead.
2. If there is no spark or intermittent spark, check black hi-voltage lead wire for damage or cracks in insulation; (This lead wire must not be taped or connected to any metal edges along its length to prevent pinching and arcing. Also, do not bundle this wire with other wires.)

Note: Spark gap and electrode location are important. If the electrode is damaged or mounting is changed the spark gap may not be correct for ignition to occur. Check for cracks in the ceramic insulator. Replace electrode assembly if necessary. Also check for carbon or foreign material on the electrodes and clean if necessary.

## Gas Valve & Manifold Removal

1. Disconnect union at gas valve and disconnect wires from gas valve operator coils.
2. Remove right manifold mounting bracket screws and slide manifold to remove from left bracket.



## Section 5: Trouble Shooting

### Common Troubleshooting Solutions

Symptom	Probable Cause	Suggested Remedy
<b>Tumbler does not turn</b>	Drive belts	Check both drive belts
	Overtemp Thermostat	Check to see if manually resettable thermostat is kicked out.
	Drive Motor	Check capacitor and motor
	Door Switch	Check door switch contacts and adjustment
	Dry Timer	Check for time on dry timer and for circuit between A & M [on rear of timer]
	Cool-Down Timer	Check for time on cool-down timer. Check circuit between A & M [on rear of cool-down timer]
<b>Tumbler turns but no spark at burner</b>	Dry Timer	Check for time on dry timer and for circuit between A & M [on rear of timer]
	Thermostat	Check switch contacts for continuity.
	Ignition transformer	Check for 24 V. out of transformer
	Ignition control	Try another control if 24 vac on red and yellow from transformer at connector.
	Air flow switch	Check for circuit through air flow switch
	Hi-limit	Check hi-limit (This is manually resettable and located at rear next to exhaust outlet.)
	Gas supply	No gas can cause system lockout
	Spark Electrode	Check electrode for damage to electrode or mounting
<b>Tumbler turns ignition sparks no flame</b>	Gas supply	Make sure gas supply is working
	Gas pressure	Make manometer check of gas pressure
	Spark electrode	Check electrode for damage to electrode of mounting
	Gas valve	Check coil continuity, replace valve if bad
Slow drying	Thermostat	Check shut-off temperature of thermostat. Compare to other dryers if possible.
	Airflow	Restrictions
	Lint screen	Clean screen
	Exhaust	Check complete exhaust system for any restrictions, lint clogged exhaust lines, too many elbows, too long of exhaust lines, or anything to obstruct proper air flow through the dryer.
	Damper	Check that dampers in exhaust open when machine is operating
	Makeup air	Check for adequate makeup air and properly sized make up air openings.



---

## Kits, Assemblies, & Common Parts

Loading Door Components	Part Number
Door Handle	9244-082-001
Door Switch	9539-461-001
Electrical Components	Part Number
Relay, Motor Run	5192-295-011
Transformer, Control	8711-007-001
Heating Circuit Components	Part Number
Ignition Control Module	9857-116-003
Ignition Electrode Assembly	9875-002-003
Thermostat, Hi-Limit	9576-203-002
Thermostat, Overtemp	9576-207-006
Fuseholder	9200-001-002
Fuse 1.5 amp	8636-018-001
Cabinet Components	Part Number
Cleanout Duct Assembly 8"	9973-034-001

---

## Section 6:

Parts Data

N-Series On-Premise

**Models**  
**DRH80**

## Cabinet Group by Part #

Key	Part Number	Description	
*	9960-256-021	Door Assy., Loading Complete-Wht	1
*	9960-256-025	Door Assy., Loading Complete-SS	1
1	9960-255-007	Door Assy., loading-SS	1
2	9982-280-002	Plate Assy., Hinge (Wht)	1
2	9982-280-011	Plate Assy., Hinge (SS)	1
*	9545-012-015	Screw, Hinge to Door 10-32 x 3/8"	4
*	8640-413-002	Nut, Hinge to Door #10-32 UNF	4
3	9212-002-003	Glass, Door	1
4	9206-164-009	Gasket, Glass	1
*	9548-117-000	Support, Odor Glass (inside gasket)	1
5	9206-420-002	Gasket, Outer Rim	1
6	9244-082-001	Handle, Loading Door	1
*	9545-018-017	Screw, Handle 1/4"-13 x 1 1/4"	2
*	9531-033-001	Stud, Door Catch	1
*	8640-413-001	Nut, Hex	
*	8640-413-003	Nut, Acorn # 10-32	1
*	9086-015-002	Catch, Loading Door	1
7	9989-460-003	Panel Assy., Front- white	1
7	9989-460-001	Panel Assy., Front- S. Steel	1
8	9108-100-001	Door, Upper Service-S.S	1
8	9108-100-003	Door, Upper Service-White	1
9	9578-090-002	Trim, Door-Upper Service	1
*	6292-006-006	Key ( only ) (FJWCC)	1
10	8650-006-003	Lock w/ nut, Upper Service Door	1
*	8638-211-001	Rivet, Drive	2
*	8641-581-005	Washer, Flat 3/16"	2
*	9548-243-002	Support, Upper Door	1
11	9412-083-001	Nameplate, Commercial Dryer	1
12	9545-012-003	Screw, Chrome 10-32 x 1/2"	4
*	8641-436-004	Washer, Fiber	4
*	8641-582-019	Lockwasher # 1 O	10
*	8640-399-001	Nut, Spring U type 1 OZ	6
13	9544-047-002	Strap, Hinge (White)	1
13	9544-047-007	Strap, Hinge (Gray)	1
*	9545-008-008	Screw, Hinge to Panel 10T-32 x 1/2"	4
14	9545-052-001	Screw, Door to Hinge Strap (special)	1
*	8641-436-003	Washer, Fiber/ Plastic	1
15	9960-261-001	Door Ass y, Lower Service-SS	1
15	9960-261-003	Door Ass y, Lower Service-White	1
16	9578-088-001	Trim, Door - Lower Service	1
17	9545-008-021	Screw,Pn Hd Cr., #10Bx3/8	5
18	9578-084-002	Trim, Kick- Lower Service Door	1
19	9545-008-010	Screw, Tr Hd Cr'-#10x1/2 Blk	3
20	8650-026-001	Latch, Lower Door (Thumbturn)	1
*	8544-005-000	Leg, Leveling	4
*	9049-074-001	Baffle, Cabinet- Left	1
*	9049-074-002	Baffle, Cabinet- Right	1
*	9545-008-003	Screw, #10x1/2 TEK	8
21	9074-273-001	Cover, Cabinet	1
22	9545-008-024	Screw	10

\* Not Illustrated

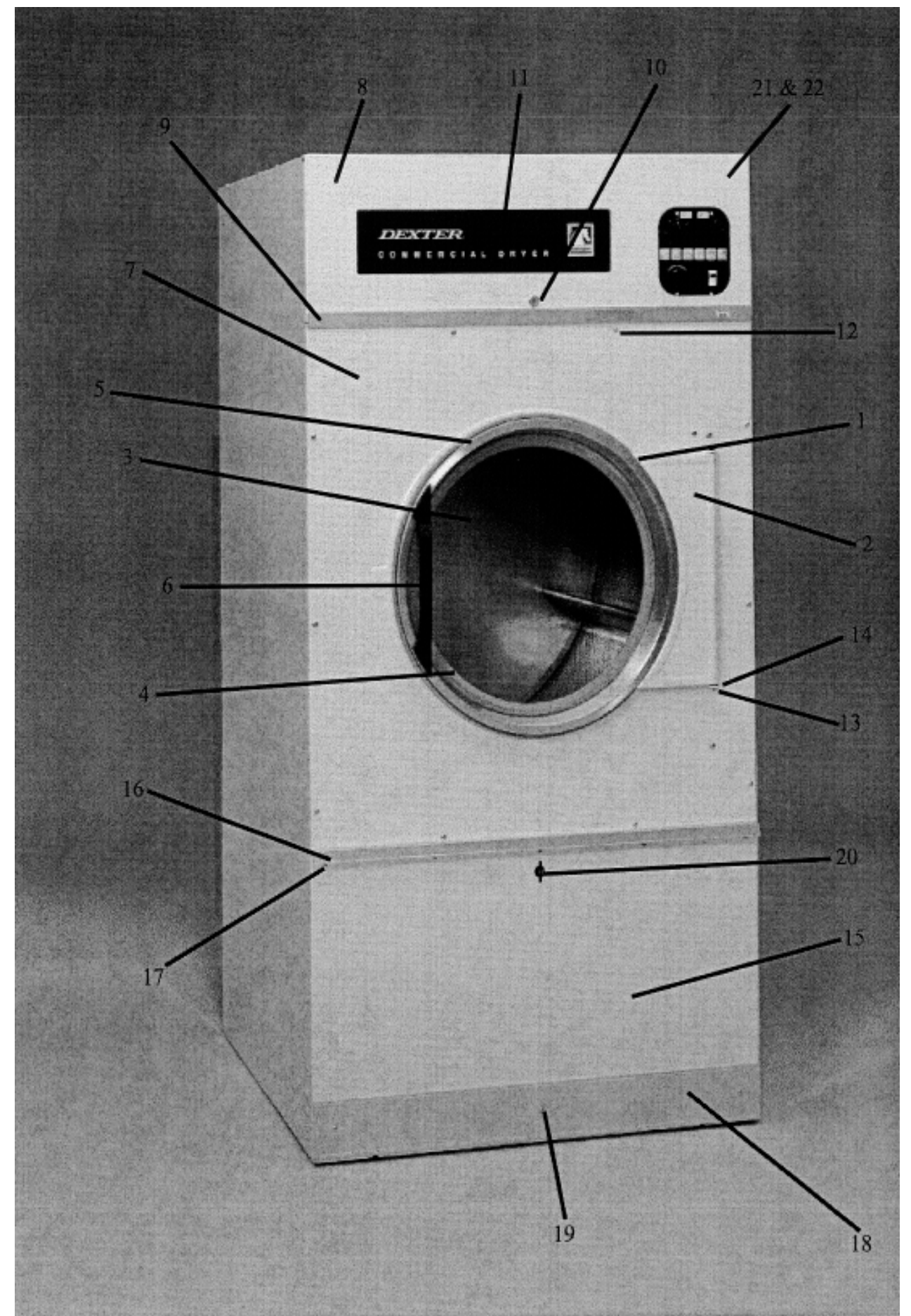

## Control Housing Group Part # by Model

Key	Part Number	Description	Qty
1	9571-350-004	Timer, Dry Time	1
2	9571-350-004	Timer, Cool-down Time	1
3	9307-176-001	Knob, Timer	3
*	9545-010-003	Screw, Hx #8-32x3/16	4
4	9539-460-002	Switch, Push-To-Start	1
5	9576-209-003	Thermostat, Temp. Control	1
6	9029-085-001	Bracket, Thermostat	1
7	9307-176-001	Knob, Temperature Control	1
*	9545-045-008	Screw, #8 Abx3/8	6
*	9029-088-001	Bracket, Bulb Mtg	1
*	9079-121-002	Clamp, Tube	1
8	9452-666-002	Plate Assembly.Control Mounting	1
9	9451-146-005	Pin- Hinge meterplate	2
10	8527-114-001	Decal, Control Panel	1
11	9054-045-001	Fuseholder	1
12	8636-018-001	Fuse	1
13	9857-116-002	Control, Ignition	1
14	9631-403-003	Wire Ass'y High Voltage	1

\* Not Illustrated

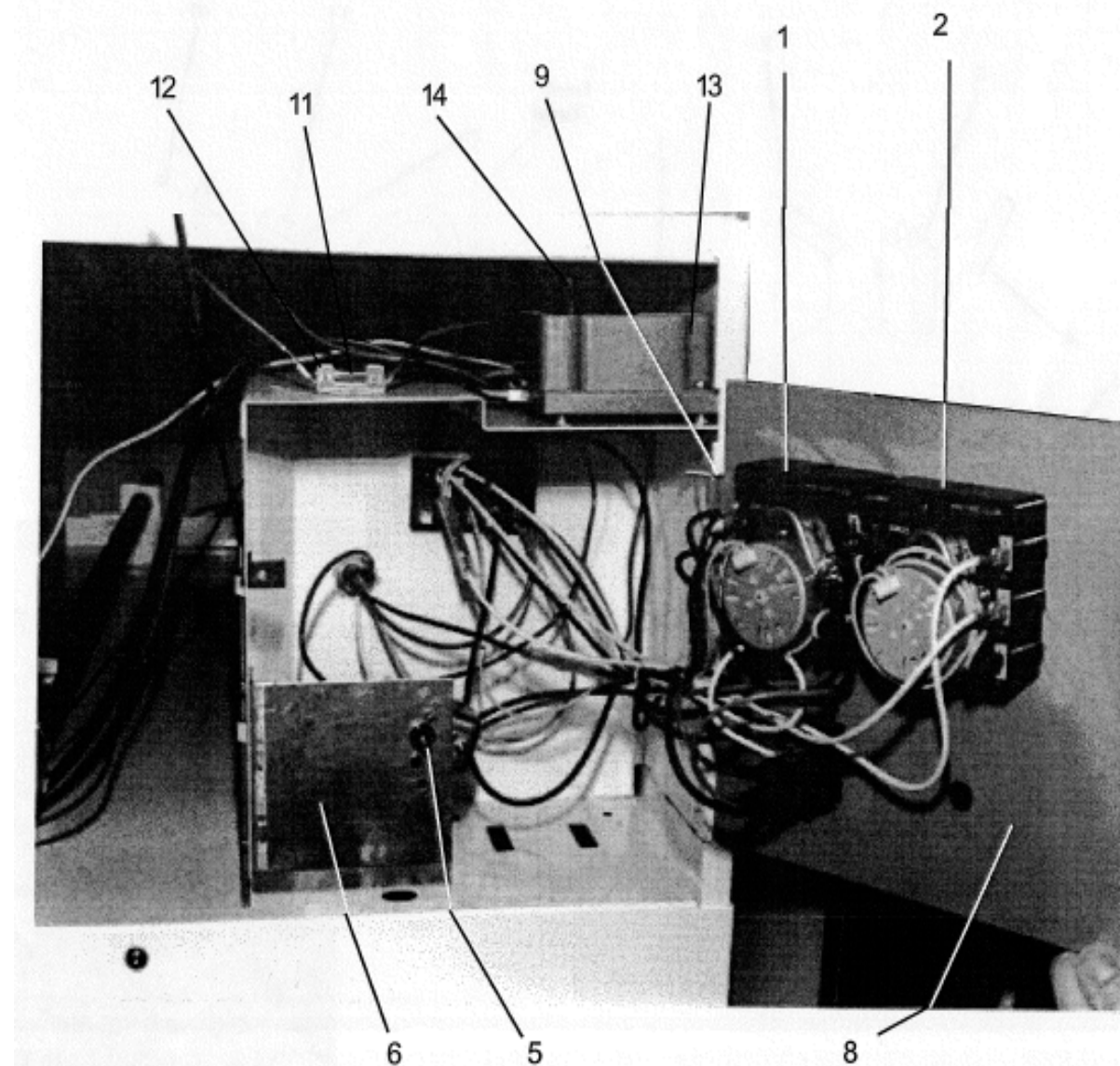

## Drive Group by Part #

Key	Part Number	Description	Qty
1	9376-299-002	Motor, Drive	1
*	9545-014-004	Screw, Hx 5/16	4
*	8640-400-003	Nut	4
2	9453-157-001	Pulley, Motor	1
*	9545-028-013	Screw, Set	2
3	9991-054-002	Support Ass y, Motor	1
4	9545-029-005	Screw 3/8-16 x 1"	4
4	8640-415-004	Nut	4
*	9278-037-003	Impeller	1
*	9074-275-003	Cover, Impeller Formed	1
*	9545-008-001	Screw, Hx#10x1/4	4
5	9991-053-001	SupportAssy, Intermed. Pulley	1
6	9545-029-010	Bolt, Rd Hd	3
7	9545-029-003	Screw	1
8	8640-415-004	Nut	3
*	8641-581-035	Washer, Flat	4
9	9861-024-003	Arm Assy-Tension Complete after serial# 124816	1
9	9861-024-001	ArmAssy-T nsion, Complete	1
*	8641-581-035	Washer, Flat	6
*	9487-200-003	Ring-Retaining	2
10	9908-042-006	Pulley Assy, Intermediate after serial number #124816	1
10	9908-042-003	Pulley Assy, Intermediate	1
*	9036-159-007	Bearing, Ball-Idler Pulley	2
*	9538-173-002	Spacer, Bearing	1
11	9908-043-002	Pulley Driven	1
*	9487-234-001	Ring, Tolerance	1
12	8641-581-026	Washer, Flat	1
*	8641-582-016	Lockwasher	1
13	9545-017-009	Screw, Hx Cap	1
14	9040-077-004	Belt, Final Drive	1
15	9040-077-003	Belt, Motor Drive	1
16	9534-151-000	Spring, _ Belt Tension	1
17	9099-012-002	Chain, Spring Tension	1
18	9248-022-002	Hook, Tension	1
*	9208-050-001	Guard, Drive	1
*	9454-685-001	Panel, Drive Guard, RH	1
*	9454-686-001	Panel, Drive Guard, LH	1
*	9550-175-001	Shield, Motor	1
*	9545-008-003	Screw	2
*	9545-008-024	Screw	17

\*Not illustrated

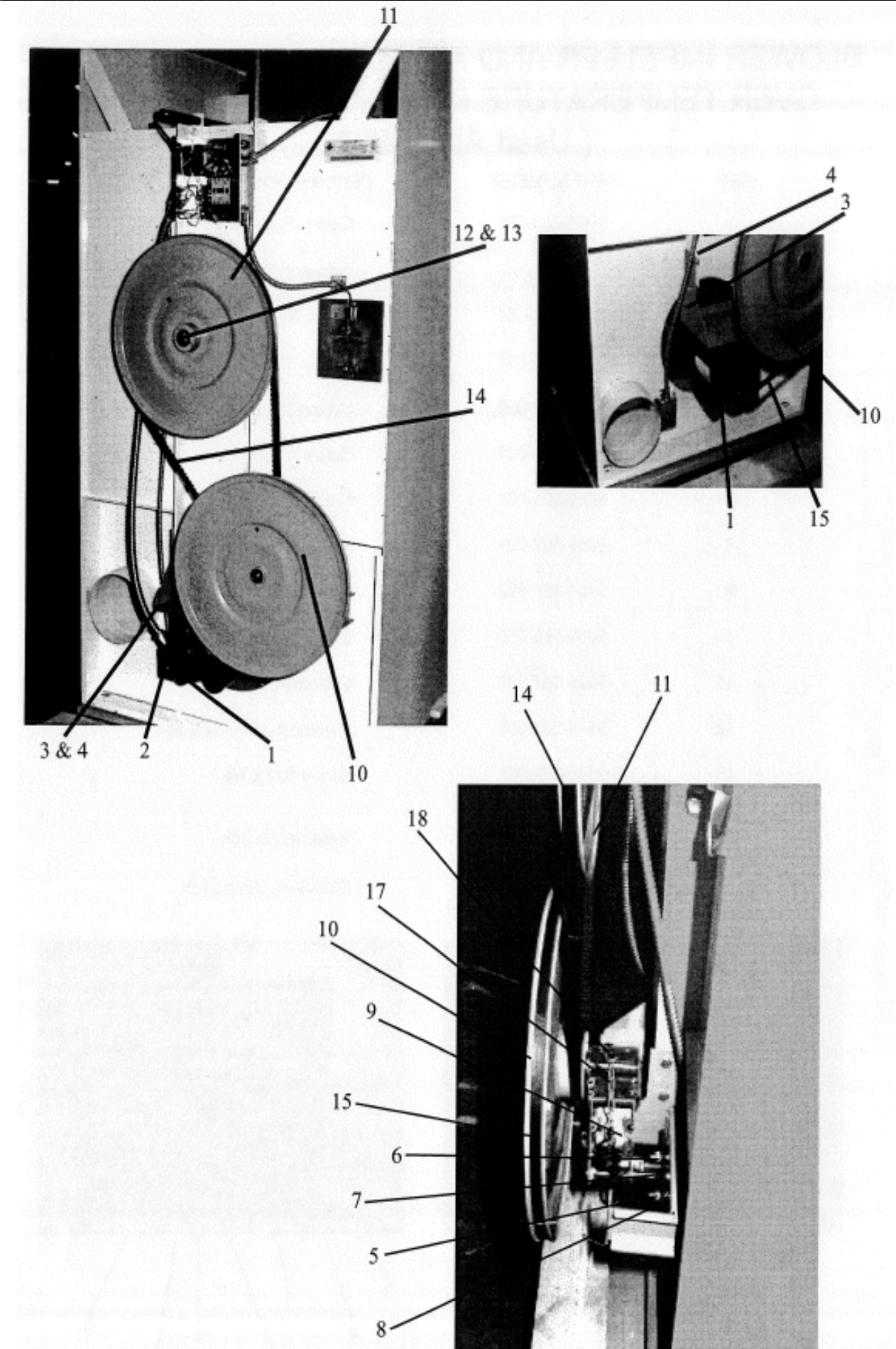

## Control Box Group by Part #

Key	Part Number	Description	Qty
1		Control Box	1
*	9074-280-001	Cover, Control Box	1
*	9545-008-024	Screw	4
2	5192-295-011	Relay-	1
*	9545-045-007	Screw, #8ABx 3/8	2
3	9897-035-002	Terminal Block Assembly, Power	1
4	9558-029-003	Strip, Terminal Marker	1
*	9545-045-007	Screw, #8A8x 3/8	2
5	9897-034-001	Terminal Block Assembly	1
6	9558-027-001	Strip, Terminal Marker	1
7	8652-134-001	Terminal Lug	1
8	8639-621-007	Screw, Hx #10-32 x 1/2	1
*	8641-582-006	Lockwasher, Ex Tooth# 10	1
9	8711-007-001	Transformer, Control	1
*	9545-012-009	Screw , Hx. #10ABx3/8	2

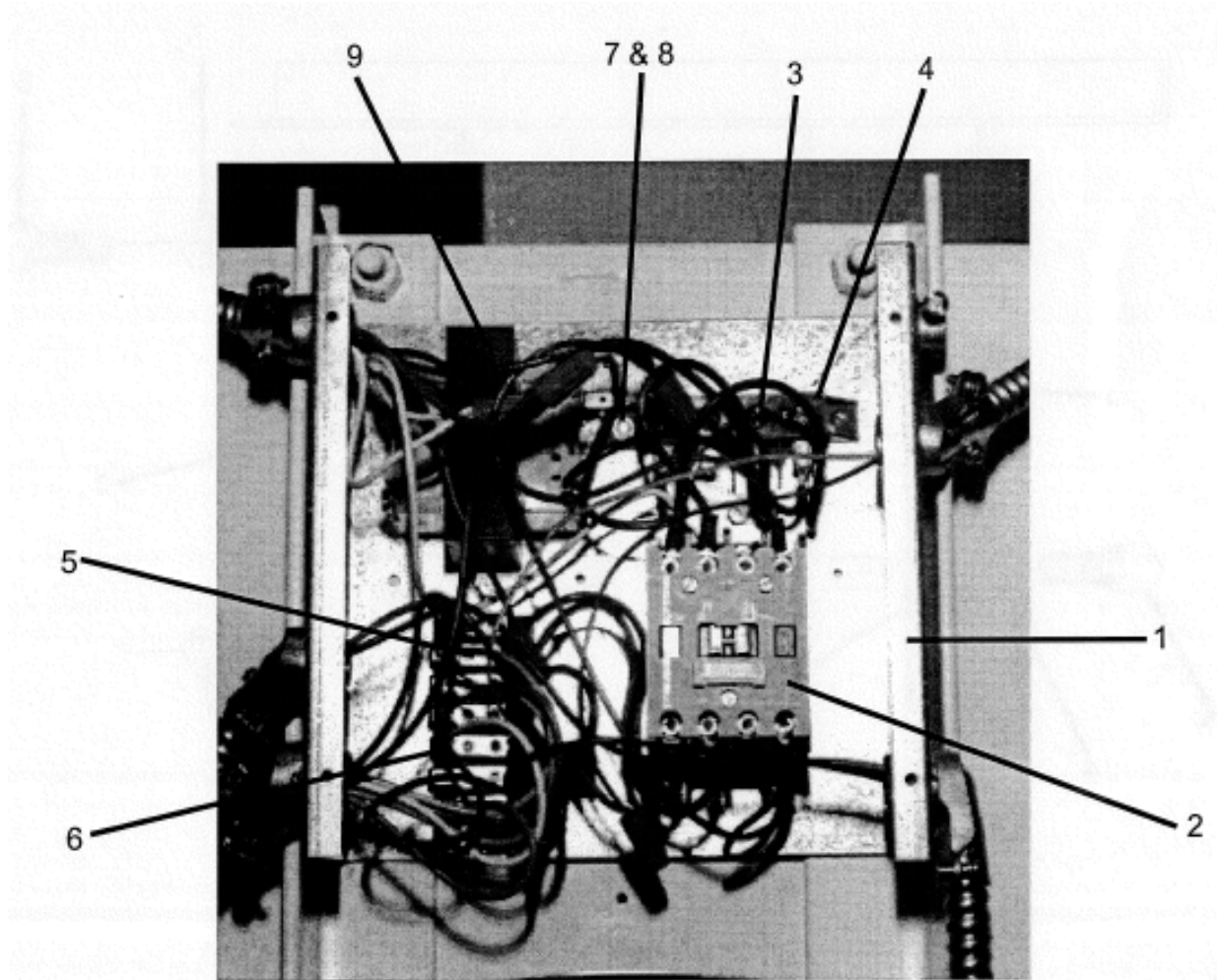

## Door Switch Group by Part #

Key	Part Number	Description	Qty
1	9041-076-001	Box, Door Switch	1
2	9550-159-001	Shield, Poor Switch	1
3	9539-461-001	Switch, Door	1
4	8640-401-001	Nut, Special Twin	1
5	9545-020-001	Screw, Pn Hd Sl.#4-40 x 3/4	2
6	9074-255-001	Cover, Switch Box	1
7	9545-008-020	Screw, Box Cover	2
8	9008-004-001	Actuator, Switch- Lower	1
9	6068-041-001	Conduit.	1
10	9545-012-003	Screw	2
*	8641-436-000	Washer, Fiber	1
11	8640-413-004	Nut, Elastic Stop	2

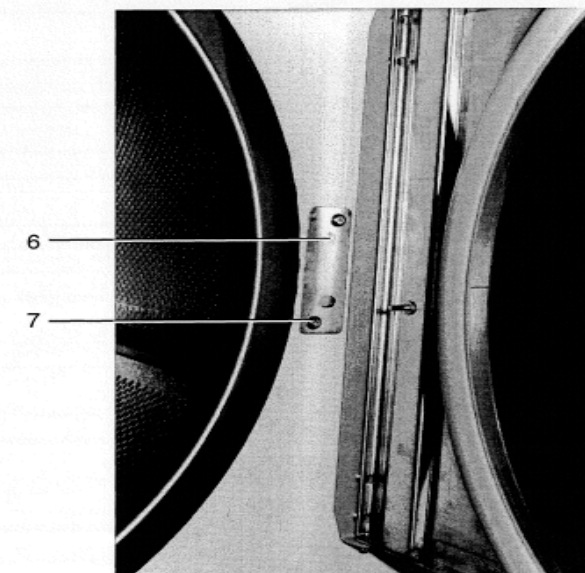
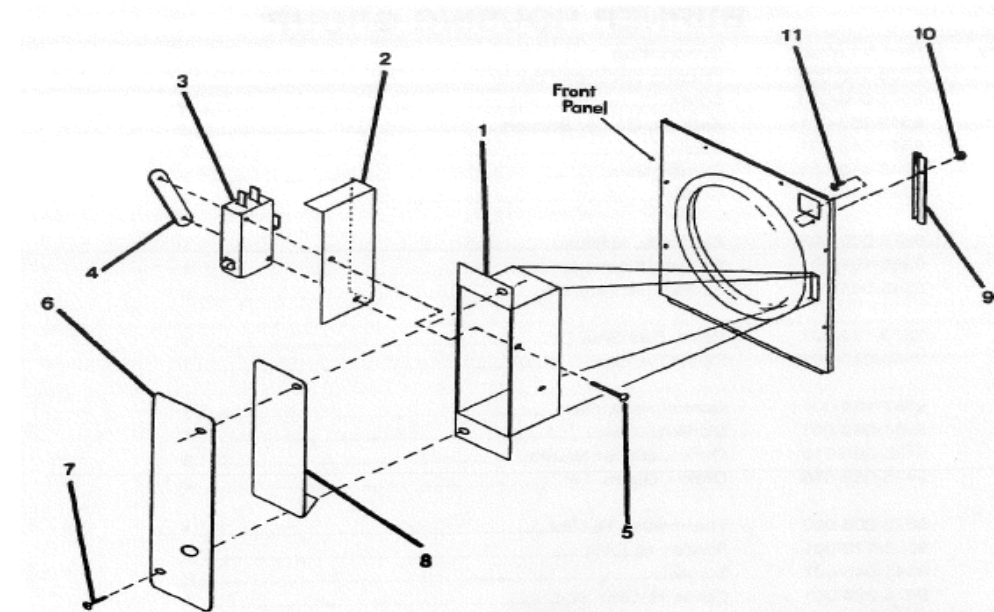

## Burner Housing Group by Part #

Key	Part Number	Description	Qty
1	9803-190-001	Housing Assembly, Burner	1
*	9545-008-024	Screw	4
*	9548-280-001	Support, Front Burner Support	1
*	9545-045-001	Screw 8B x 1 1/4"	2
2	9048-018-001	Burner, Main	4
*	9545-045-001	Screw 8B x 1/14"	4
3	9875-002-002	Electrode, Ignition	1
4	9452-645-001	Plate, Electrode Mtg	1
*	9545-045-001	Screw, Electrode Mtg 88 x 11/4"	2
5	9379-164-002	Valve, Gas Shut Off	1
*	9458-020-003	Pipe, Gas Line	1
6	9857-134-002	Control Assy, Gas	1
*	9381-010-001	Manifold, Assy 3 port (Before serial number 153714)	1
22	9425-069-013	Orifice, Burner-Natural (Used only for 3 port burner manifold)	3
*	9425-069-006	Orifice LP (Used only for 3 port burner manifold before number 153714)	3
7	9381-011-001	Manifold, Assy 4 port (After serial number 153714)	1
7	9425-069-021	Orifice, Burner-Natural (Used after serial number 153714)	4
*	9425-069-006	Orifice LP (Used in kit #9732-102-010) after serial number 153714	4
*	9379-164-002	Union	1
8	9576-203-002	Thermostat, Hi-Limit	1
*	9538-142-001	Spacer, Hi-Limit	2
*	9545-045-007	Screw 88 x 3/4"	2
9	9074-234-001	Cover, Hi-Limit Stat	1
*	9545-008-024	Screw 10 Bx 3/8"	1
10	9857-116-002	Control, Ignition	1
*	9545-044-002	Screw 6-32 x 1"	2
*	8640-411-003	Nut, Hex Keps #6-32	2
*	9897-026-001	Terminal Block Power (Inside Front Control Panel)	1
*	9545-031-004	Screw 6 AB x 5/8"	2
*	9039-915-001	BRACKET, Pipe	1
*	9545-031-004	Screw 6AB x 5/8"	2
12	9631-403-003	Wire Ass y, High Voltage	1
*	9627-711-001	Harness, Low Voltage Ignition	1
*	9054-045-001	Fuseholder	1
*	8636-018-001	Fuse 1.5 amps .....	1
15	8711-007-001	Transformer, Control	1
*	9545-008-024	Screw, #10x1/2"	2
*	9732-102-006	Kit, LP Conversion (Use only before serial number 153714)	
*	9732-102-010	Kit, LP Conversion (Use only after serial number 153714)	

\* Not Illustrated

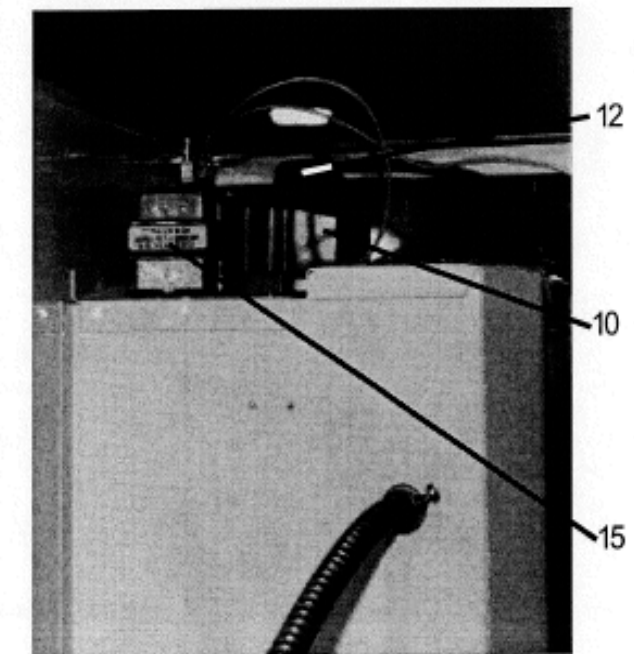
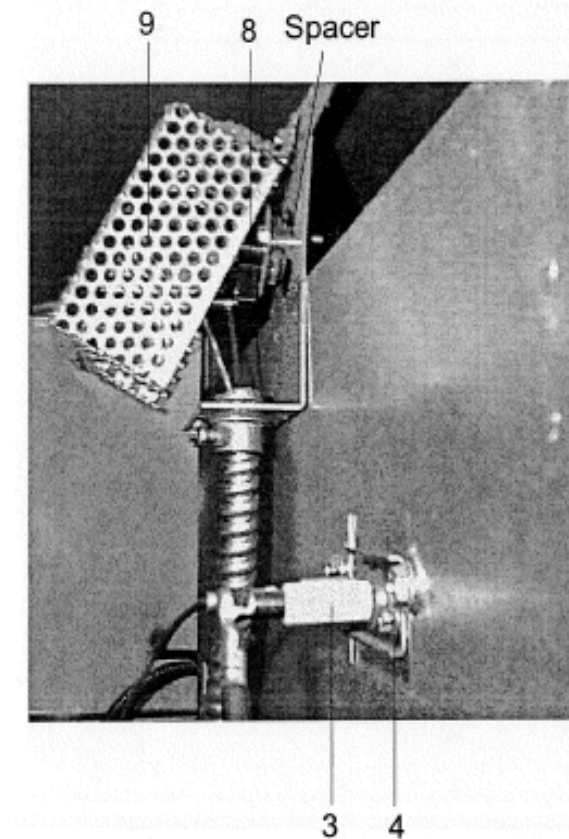
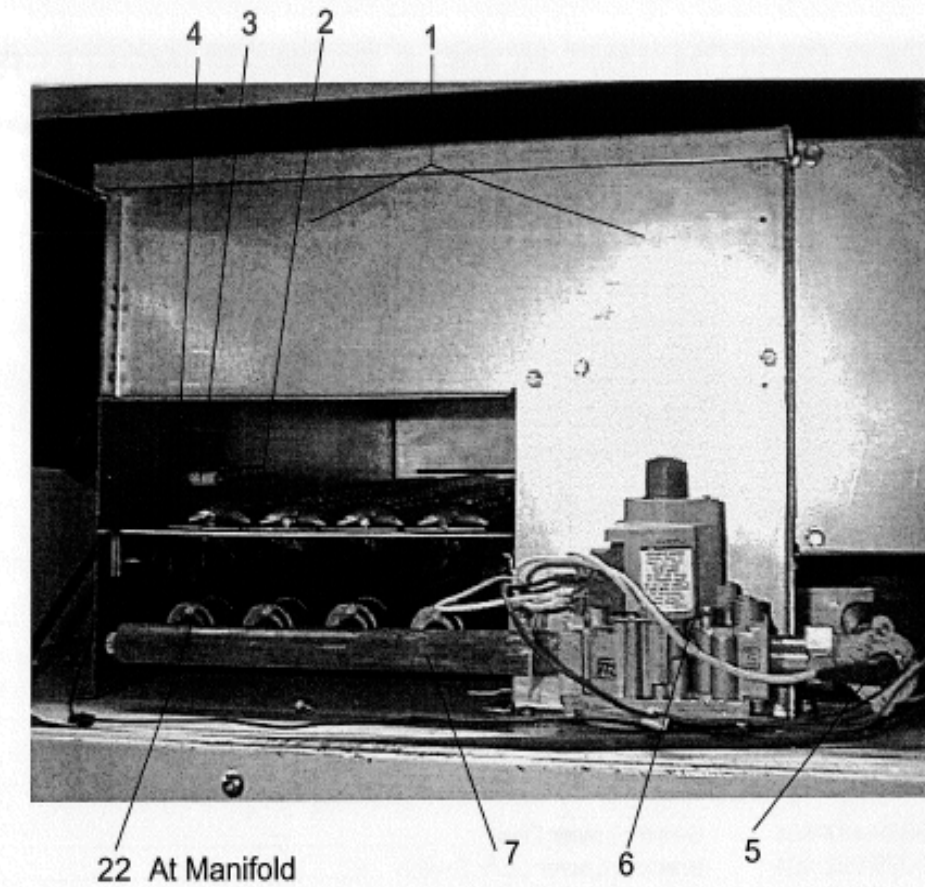

## Bearing Housing Group by Part #

Key	Part Number	Description	Qty
*	9803-189-001	Housing, Bearing Ass'y (includes #1 and #2)	1
1	9241-183-003	Housing, Bearing	1
2	9036-159-001	Bearing, Ball-Rear	1
*	9036-159-002	Bearing, Ball-Front Sold on Spider	1
3	8641-581-026	Washer, Flat.	4
4	8641-582-004	Lockwasher	4
5	9545-017-004	Bolt, 1/2-13x1	4
6	9545-059-003	Screw, 7 1/16 -14x1 1/2	2
*	8641-582-013	Lockwasher, 7 1/6	2
7	8640-416-001	Nut, 7/16 - 14	4
*	9487-234-001	Tolerance Ring	1

\* Not Illustrated

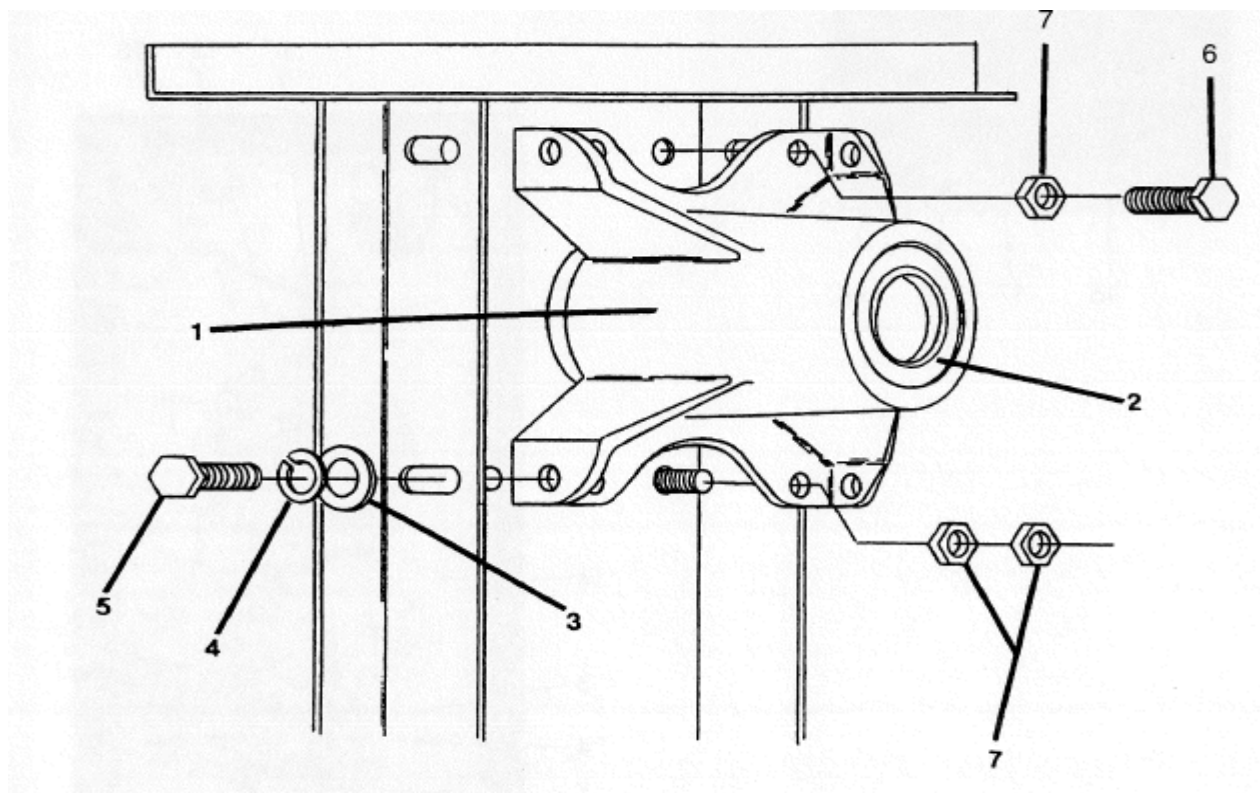

## Tumbler Group by Part #

Key	Part Number	Description	Qty
1	9848-118-001	Tumbler Ass'y.	1
2	9873-005-001	Spider Ass'y w/ bearing on	1
3	9497-226-001	Rod, Tumbler	4
4	8640-417-002	Nut	4
5	9552-013-000	Shim	4
6	8641-582-004	Washer, Spring Lock	4
7.	8641-587-001	Washer, Tumbler Rod Special	4
*	9487-234-001	Ring, Tolerance	1
8	8641-582-016	Lock Washer, Tumbler Shaft	1
9	8641-581-026	Flat Washer, Tumbler Shaft	1
10	9545-017-009	Screw, Tumbler Shaft.	1

\* Not Illustrated

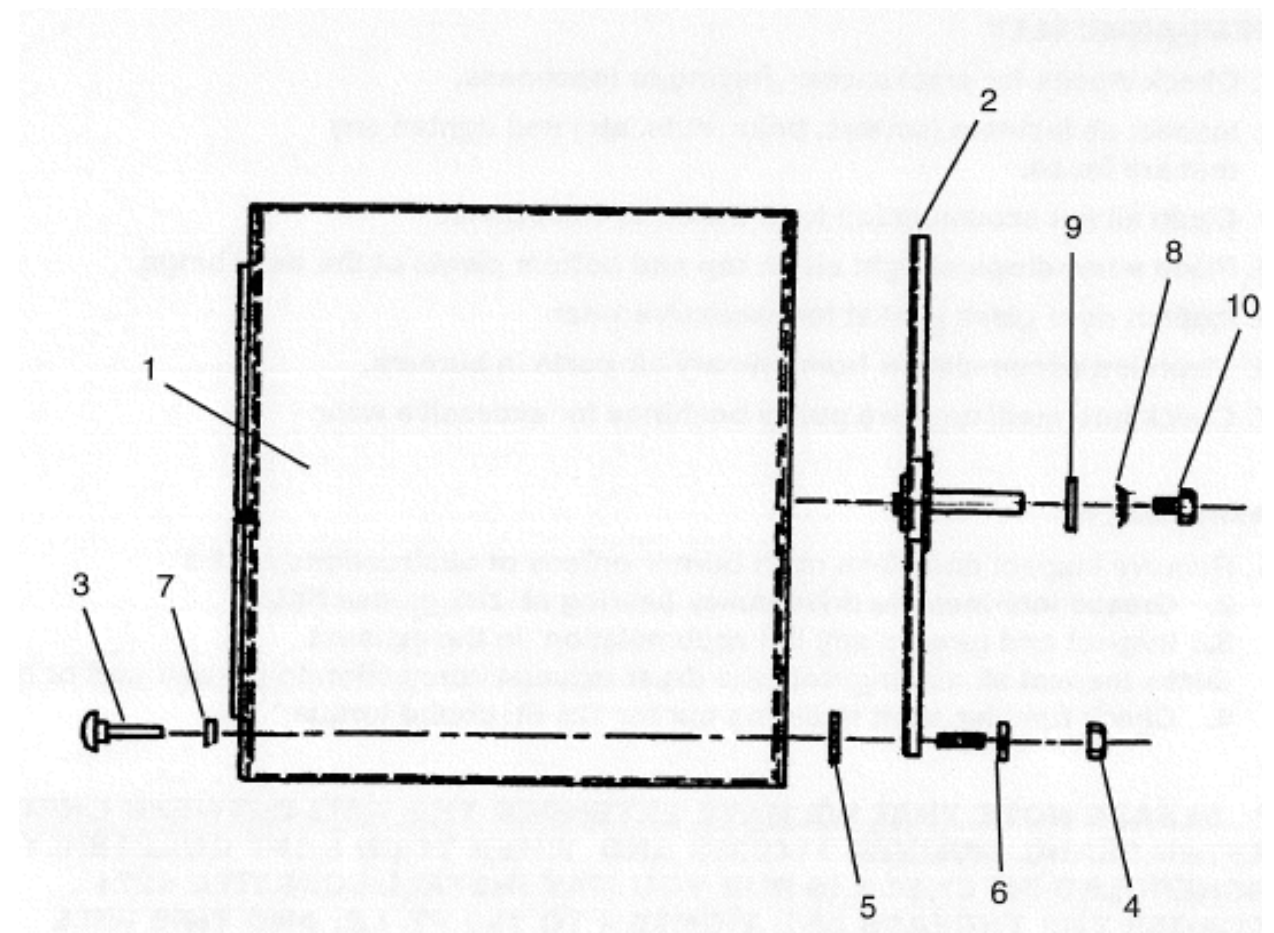

## Damper Switch, Lint Hood, & Blower Impeller Group Style No. 1 (in use since 1998)

Key	Part Number	Description	Qty
1	9539-432-001	Switch, Damper	1
*	9545-044-002	Screw, Hx #6-32x1	1
*	8640-411-003	Nut, Hex #8-32	1
*	9545-044-002	Screw, Hx 6-32x1	2
*	8640-420-001	Nut, Speed Tandem	1
2	9125-001-001	Damper	1
3	9451-146-001	Pin, Damper Hinge	1
4	9074-242-002	Cover, Damper Switch	1
*	9209-037-002	Grommet.	1
5	9834-008-001	Hood Ass'y, Lint	1
6	8640-412-004	Nut, Whizlock	6
*	9822-031-001	Lint Screen 21"x36" (old style)	1
7	9576-207-006	Thermostat, Safety	1
*	9545-008-001	Screw, Hx. #10 x 1/4	2
8	9539-487-001	Switch, Lower Door	1
9	9029-092-001	Bracket, Lower Door Switch	1
*	9545-008-024	Screw	2
10	9278-037-003	Impeller, w/set screws	1
*	9345-824-002	Schematic Wiring	1
*	9345-825-002	Diagram Wiring	1

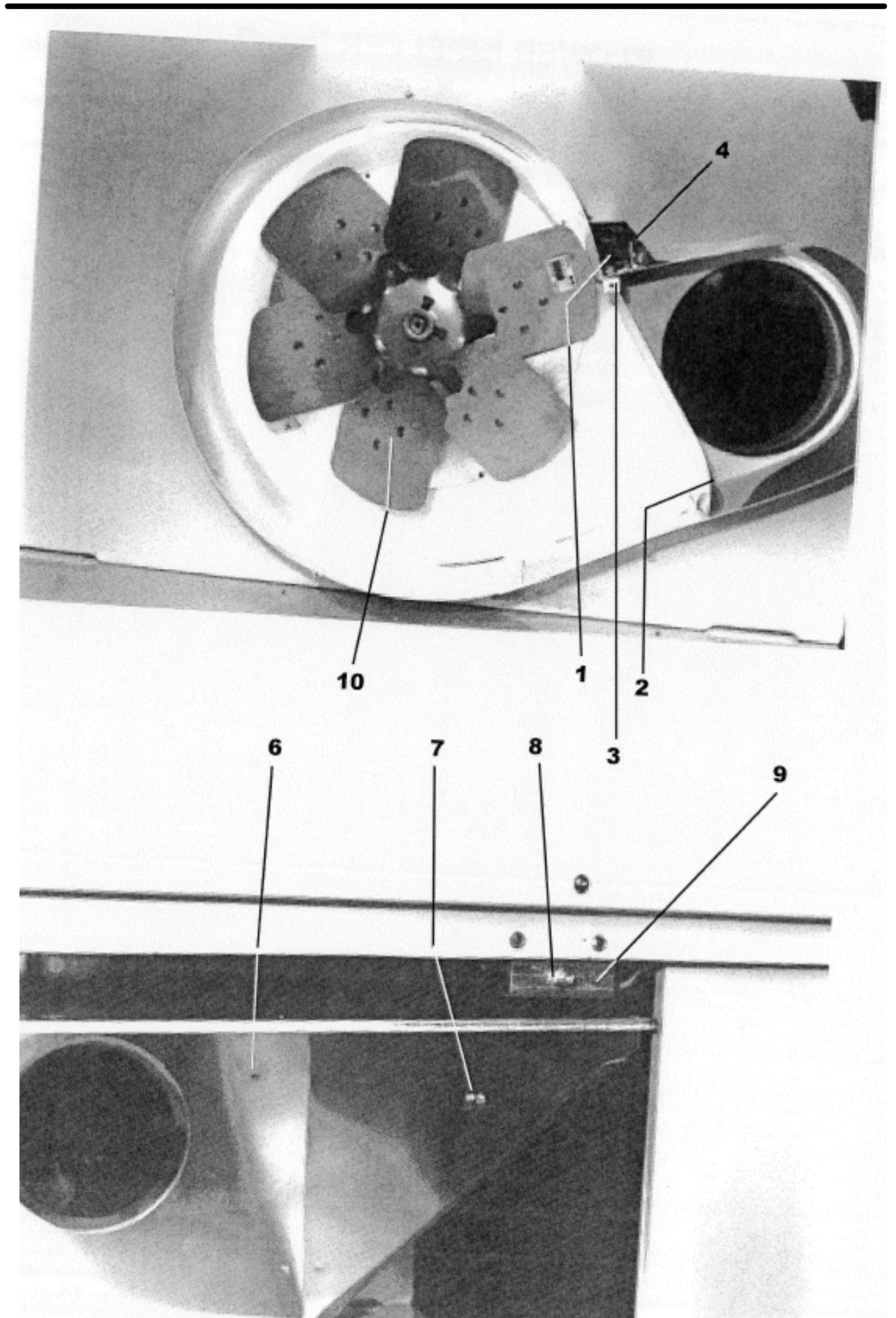

# Lint Hood, & Blower Impeller Group Style No. 2 (in use since 1998)

Key	Part Number	Description	Qty
1	9822-031-002	Lint Screen Ass'y 21"x34"	1
2	9278-038-003	Impeller	1
3	9834-009-001	Hood assembly Lint	1
*	9345-824-008	Schematic Wiring	1
*	9345-825-009	Diagram Wiring	1

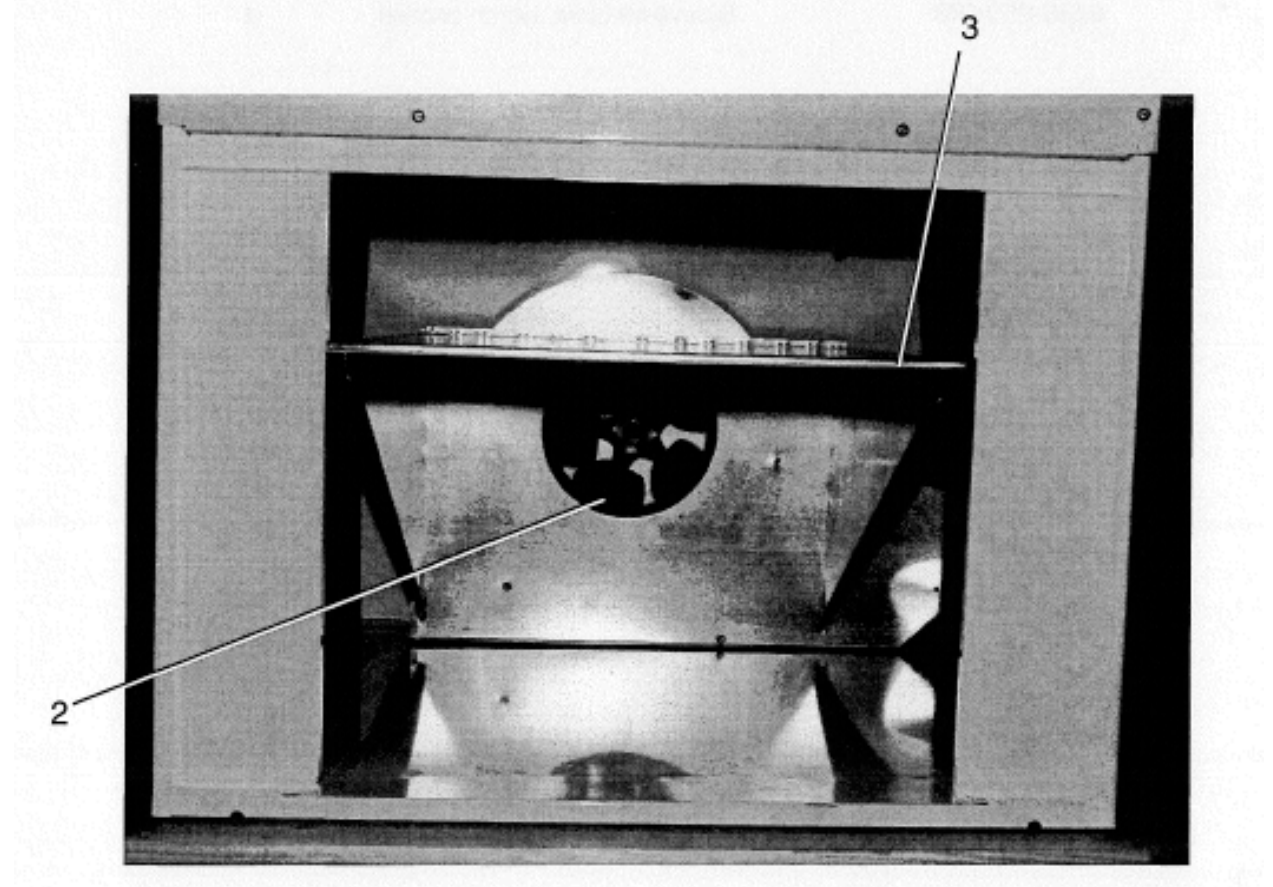
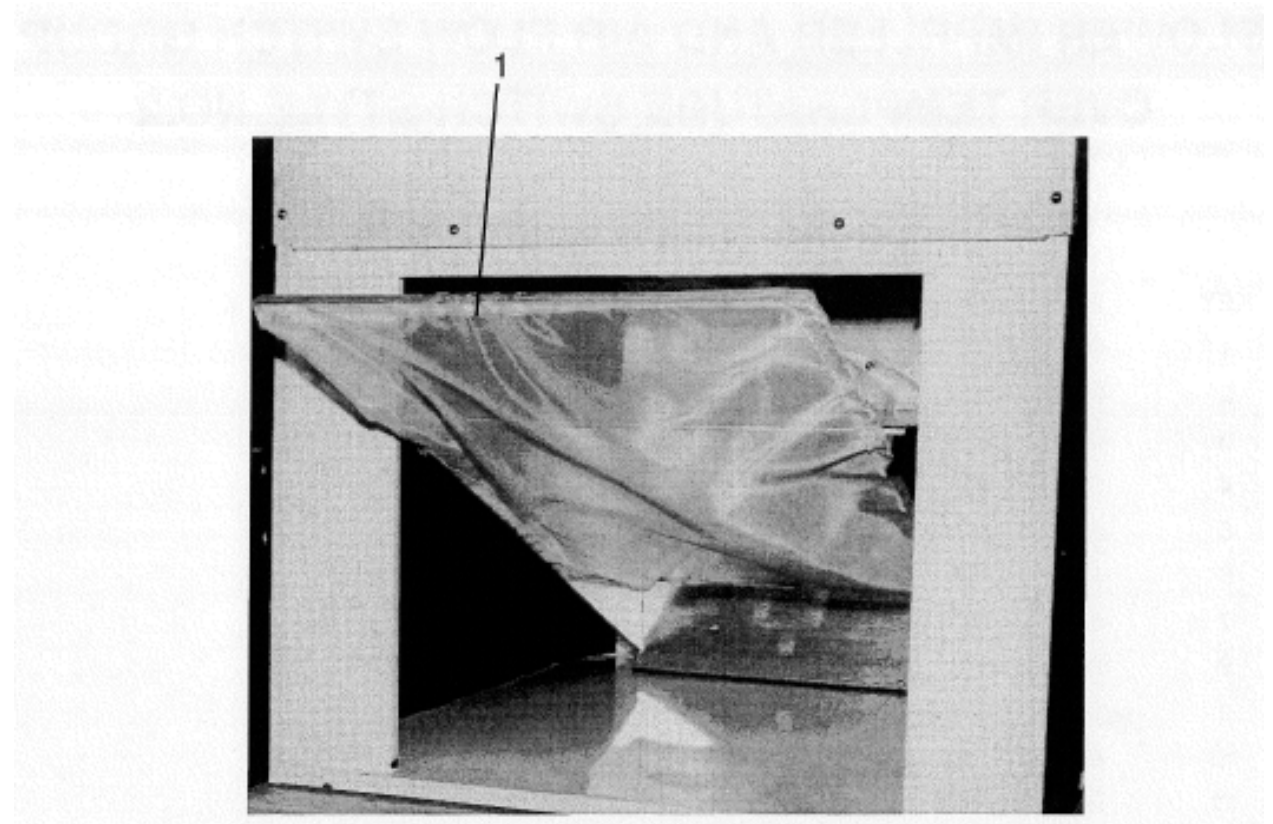

## Blower Impeller and Airflow Switch Group Overtemperature Switch Style No. 2 (in use after 1998)

Key	Part Number	Description	Qty
1	9074-283-001	Cover Plate	1
2	9029-046-001	Actuator Stop	1
3	9029-100-001	Bracket -Switch	1
4	9545-008-001	Screw-JOB .x 1/4	4
5	9539 461-009	Switch-Micro	1
6	9545 020-001	Screw 4-40 x %	2
7	8640-401-001	Nut Twin	1
8	9008-007-001	Actuator-Switch	1
9	9451-169-002	Pin Cotter	1
10	9039-575-000	Bracket Conduit	1
11	9825-057-002	Over-temp cover ass'y	1
12	9576-207-006	Thermostat Over-temp Manual Reset (Manually Resettable)	1
13	9545-008-001	Screw 108 x 1/4	2
*	9486-137-001	Retainer; pushon	1
*	9535-050-003	Sleeve-Hi-Limit switch access	1

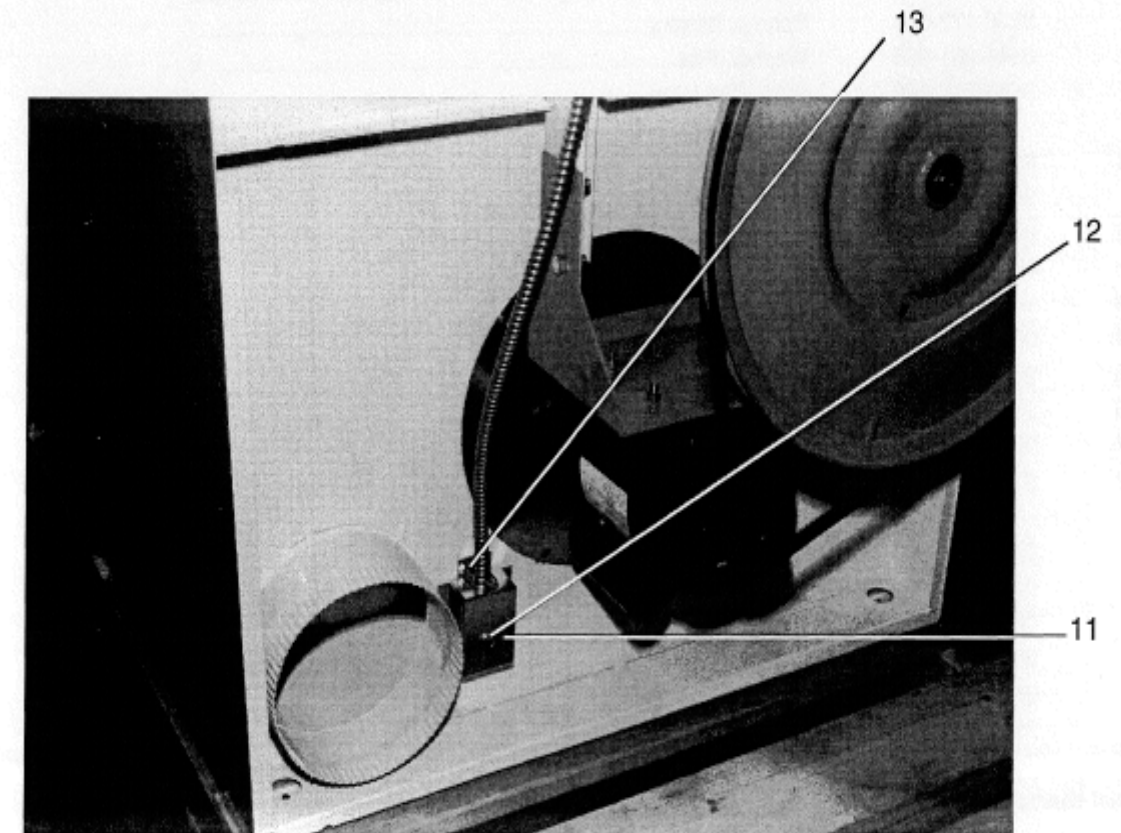
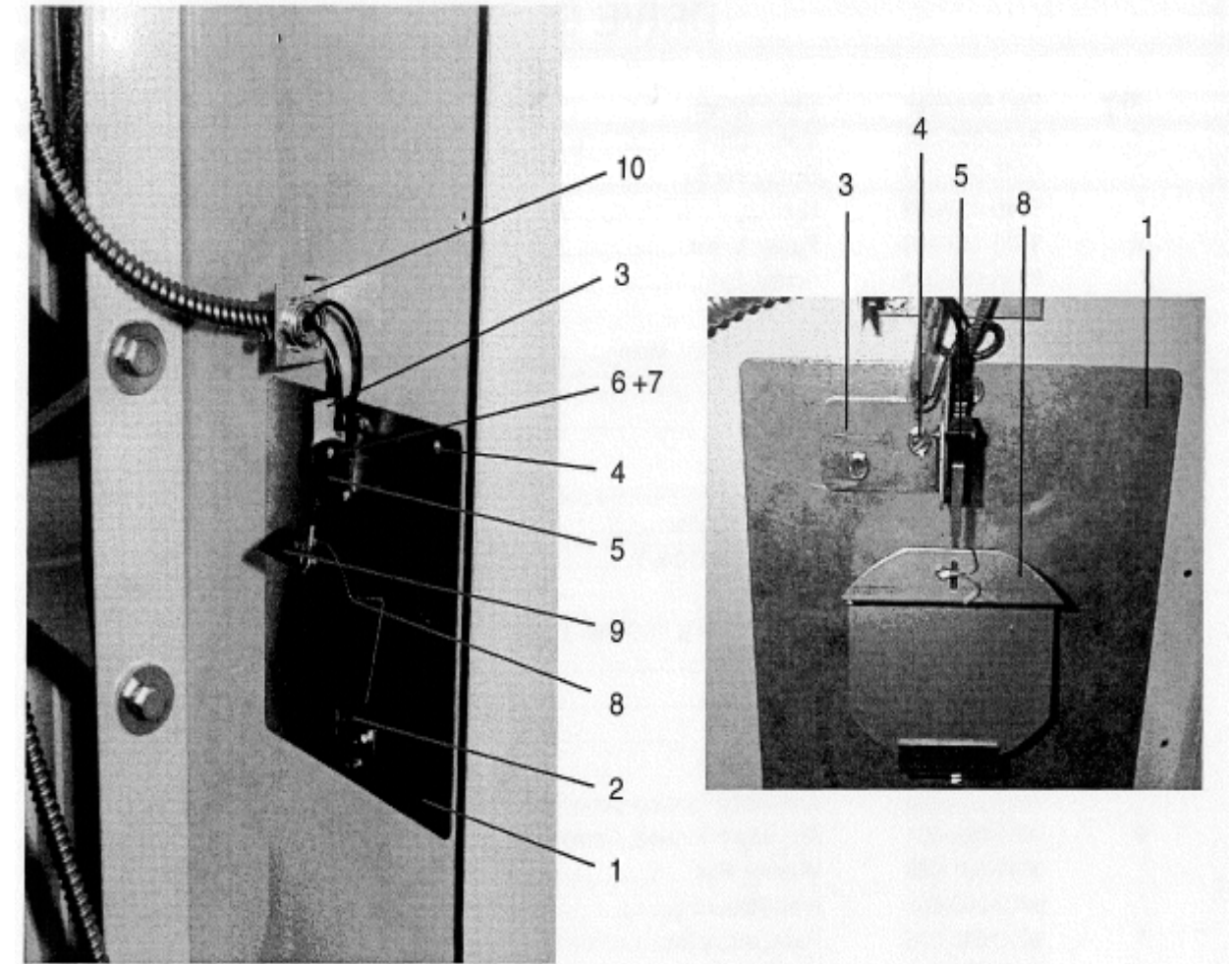

---

# Section 7:

## Maintenance

---

## Preventative Maintenance

MAKE SURE ALL POWER IS DISCONNECTED BEFORE MAKING CHECKS INSIDE MACHINE.

### DAILY

1. Clean lint screen using a soft brush if necessary. Check lint screen for rips or tears and replace as necessary

### MONTHLY

1. Clean lint from motor end bells and dryer controls area.
2. Clean lint from lint screen compartment.
3. Clean lint accumulation from top and all areas above, around and below burners and burner housing.

Failure to keep this section of dryer free from lint can create a fire hazard.

### SEMI-ANNUALLY

1. Check V-belts for cracks, wear, fraying, or looseness.
2. Inspect all fasteners (screws, bolts, nuts, etc) and tighten any that are loose.
3. Clean all lint accumulation from inside of front panel.
4. Place a few drops of light oil on top and bottom pivots of the door hinge.
5. Inspect door glass gasket for excessive wear.
6. Clean lint accumulation from primary air ports in burners.
7. Check intermediate drive pulley bushings for excessive wear.

### ANNUALLY

1. Remove, inspect and clean main burner orifices of obstructions or dirt .
2. Grease intermediate drive pulley bearing at zirk grease fitting.
3. Inspect and remove any lint accumulation in the exhaust ducts. Inspect all ducting from the dryer exhaust connection to the exit wall or roof .
4. Check tumbler shaft retaining nut for 125 Ft. pound torque\*.

\* PLEASE NOTE THAT WE HAVE EXTENDED THE TIME BETWEEN CHECKS AFTER SERIAL NUMBER #149253 AND WHEN YOUR NEXT QUARTERLY SCHEDULED PM CHECK IS DUE YOU MAY INSTALL LOCKTITE #271 ACROSS THE THREADS AND TIGHTEN TO 150 FT. LB. AND THIS WILL THEN EXTEND YOUR NEXT PM CHECK TIME TO ANNUALLY.