



DEXTER[®]
LAUNDRY

**USE THE BLUE TABS LOCATED ON THE
RIGHT AND LEFT SIDES OF THE FOLLOWING
DOCUMENT TO ADVANCE TO EACH SECTION.**



DEXTER
LAUNDRY



DDAD T-30X2 Models 30 Pound Stacked Commercial Dryer

Service and Parts Manual

DDAD 30KC_ - 65, DDAD 30KC_ - 59, DDAD 30KC_ - 39

Equipment Safety Warnings Symbols and Terminology Used in this Equipment

	Indicates an imminently hazardous situation, which if not avoided, will result in death or serious injury.
	Indicates a potentially hazardous situation, which if not avoided could result in death or serious injury.
	Indicates a potentially hazardous situation which, if not avoided, may result in minor or moderate injury. It may also be used to alert against unsafe practices. Minor burns, pinch points that result in bruises and minor chemical irritation.
	Indicates information or a company policy that relates directly or indirectly to the safety of personnel or protection of property.
	This is the user caution symbol. It indicates a condition where damage to the equipment resulting in injury to the operator could occur if operational procedures are not followed. TO REDUCE THE RISK OF DAMAGE OR INJURY, refer to accompanying documents; follow all steps or procedures as instructed.
	This is the electrical hazard symbol. It indicates that there are DANGEROUS HIGH VOLTAGES PRESENT inside the enclosure of this product. TO REDUCE THE RISK OF FIRE OR ELECTRIC SHOCK, do not attempt to open the enclosure or gain access to areas where you are not instructed to do so. REFER SERVICING TO QUALIFIED SERVICE PERSONEL ONLY
	Caution! There are sharp edges on various sheet metal parts internal to the enclosure. Use safety consciousness when placing or moving your hands while working in the interior of this equipment.
	Caution! To reduce the risk of damage to the Water Inlet Valve, do not supply inlet water with a temperature that exceeds 70° C. Caution! To reduce the risk of fire or explosion, do not operate this equipment in any hazardous classified (ATEX) environment.

Equipment Safety Warnings Symbols and Terminology Used in this Equipment



Warning! Do not operate equipment if door glass is damaged in any way.



Warning! Keep clear of rotating parts.



Prohibited! Do not enter this equipment or space.



Prohibited! Do not step or stand on this equipment.



Prohibited! Do not operate without all guards and covers in place.









Prohibited! Do not operate without all guards and covers in place.



Prohibited! Do not wash or Dry clothing impregnated with flammable liquids (petrochemical).



Prohibited! Do not allow children to play in or around equipment.

 DANGER	Indicates an imminently hazardous situation, which if not avoided, <u>will result</u> in death or serious injury.
 WARNING	Indicates a potentially hazardous situation, which if not avoided <u>could result</u> in death or serious injury.
 CAUTION	Indicates a potentially hazardous situation which, if not avoided, <u>may result</u> in minor or moderate injury. It may also be used to alert against unsafe practices. Minor burns, pinch points that result in bruises and minor chemical irritation.
NOTICE	Indicates information or a company policy that relates directly or indirectly to the safety of personnel or protection of property.
	This is the user caution symbol. It indicates a condition where damage to the equipment resulting in injury to the operator could occur if operational procedures are not followed. TO REDUCE THE RISK OF DAMAGE OR INJURY, refer to accompanying documents; follow all steps or procedures as instructed.
	This is the electrical hazard symbol. It indicates that there are DANGEROUS HIGH VOLTAGES PRESENT inside the enclosure of this product. TO REDUCE THE RISK OF FIRE OR ELECTRIC SHOCK, do not attempt to open the enclosure or gain access to areas where you are not instructed to do so. REFER SERVICING TO QUALIFIED SERVICE PERSONEL ONLY
	Caution! To reduce the risk of fire or explosion, do not operate this equipment in any hazardous classified (ATEX) environment.



WARNING



- All Dryers must be installed in accordance to all applicable electrical, plumbing and all other local codes.
- These installation and operation instructions are for use by qualified personnel only. To avoid injury and electrical shock, do not perform any servicing other than that contained in the installation and operation instructions, unless qualified.



Do not install Equipment in an explosive atmosphere.



- Care must be stressed with all foundation work to ensure a stable unit installation, eliminating possibilities of excessive vibration.
- Foundation must be level within 13 mm to ensure proper washer operation.



Do not operate washer or Dryer if door glass is damaged in any way.



Do not wash or Dry clothing impregnated with flammable liquids (petrochemical).



WARNING



Children should be supervised to ensure they do not operate or play in or around equipment.







Keep all panels in place to protect against electrical shock and injury and add rigidity to washer.

This appliance is not intended for use by persons (including children) with reduced physical, sensory or mental capabilities, or lack of experience and knowledge, unless they have been given supervision or instruction concerning use of the appliance by a person responsible for their safety.

A washer should not be allowed to operate if any of the following occur:

- Excessive high water level.
- Machine is not connected to a properly earthed circuit.
- Door does not remain securely locked during the entire cycle.
- Vibration or shaking from an inadequate mounting or foundation

	Warning! Do not operate equipment if door glass is damaged in any way.
	Warning! Keep clear of rotating parts.
	Prohibited! Do not enter this equipment or space.
	Prohibited! Do not step or stand on this equipment.
	Prohibited! Do not operate without all guards and covers in place.
	Prohibited! Do not operate without all guards and covers in place.
	Prohibited! Do not wash or Dry clothing impregnated with flammable liquids (petrochemical).
	Prohibited! Do not allow children to play in or around equipment.

	Prohibited! Do not attempt to open, touch, or proceed before referring to the manual or unless qualified.
	Mandatory! Read all supporting documentation before operating or maintaining equipment.
	Mandatory! Disconnect power before servicing equipment.
	Mandatory! Lock out and tag out before servicing this equipment.
	Mandatory! Children should be supervised to ensure they do not operate equipment.

Notes

Dexter Safety Guidelines

! WARNING

For your safety, the information in this manual must be followed to minimize the risk of fire or explosion or to prevent property damage, personal injury or loss of life.

IF YOU SMELL GAS:

- Do not try to light any appliance.
- Do not touch any electrical switch: do not use any telephone in your building.
- Clear the room, building or area of all occupants.
- Immediately call your gas supplier from a neighbor's telephone.
- Follow the gas supplier's instructions.
- If you cannot reach your gas supplier, call the fire department. Installation and service must be performed by a qualified installer, service agency or the gas supplier.

Dry only fabrics washed in water to avoid the risk of fire, including spontaneous combustions, do not dry:

- Items containing foam rubber, or any similarly textured rubber-like materials.
- Any items on which you have used a cleaning solvent or which contain flammable liquids or solids, such as naphtha, gasoline, or other oils or waxes.

To activate your warranty, be sure to return your red warranty form to the factory. Please have serial number and model ready when calling for assistance.

Table of Contents

Section 1:

Specifications 14

Section 2:

Installation and Operation

Installation Clearances 16

Make Up Air 16

Electrical Requirements 16

Gas Requirements 16

Burner Set Up 16

Exhaust Installation 16-19

Installation Dimensions 20

Operating Instructions 21

Characteristics of a Running Dryer 21

Description of Control 22

Programmed Data 23

Dexter Control Features Activation

 Procedure 24

Entering Program Mode 24

Programming 24

Exiting Program Mode 24

Programming Example 24

Section 3:

Wiring Schematics

Dryer Idle- No Coins Added 26

Coins Added-Motor Starting and

 Running 26

Heat Circuit 26

Over Temperature Thermostat 27

Cool Down 27

End of Cycle 27

Wiring Diagram for DDAD Dryer. 28 & 30

Wiring Schematic for DDAD Dryer.. 29 &

 31

Section 1: Specifications

Specifications

30 lb. Commercial Stack Dryer Model: T30x2 - DDAD30

Cabinet Height	76 5/8"	1937 mm.
Cabinet Width	31.5"	800 mm.
Overall Depth	47 5/16"	1270 mm.
Floor to Door Bottom	Bottom 7 5/16", Top 44 15/16"	Bottom 186 mm. Top
Door Opening	25.69"	653 mm.
Dry Wt. Capacity	30 x 2 lbs.	13.608 x 2 kg.
Cylinder Diameter	30"	762 mm.
Cylinder Depth	27 1/2"	699 mm.
Cylinder Volume	11.25 cu. ft.	318 liters
Lint Screen Area	453 sq. in.	2922.57 sq. cm.
Gas Input/Hour (kW) (per pocket)	90,000 BTU (35.2)	
Gas Supply Connection	.5"	12.7 mm.
Natural Gas Supply (Water Column)	5-8"	127 mm. - 203 mm.
Natural Burner Manifold	3 1/2"	88.9 mm.
L.P. Supply (Water Column)	11.5-14"	292.1 mm. - 355.6 mm.
L.P. Burner Manifold	11"	279.4 mm.
Exhaust Size	8"	203 mm.
Make-up Air	1.5 sq. ft.	1394 sq. cm.
Motor Size	1/2 H.P.	.373 kW

Electrical Specifications - 120/60/1

Voltage/Hz/Phase	120V/60Hz/1Phase
Running Amps	19.6
Circuit Protection Amps	30
Wire Size	10 gauge
Electrical Service	2 wire + ground

Electrical Specifications - 220-240/60/1

Voltage/Hz/Phase	220-240V/60Hz/1Phase
Running Amps	10.0
Circuit Protection Amps	15
Wire Size	12 gauge
Electrical Service	3 wire + ground

No neutral optional kit available for DDAD models being wired with 208/240V: 9732-253-001

Electrical Specifications - 220-240/50/1

Voltage/Hz/Phase	220-240V/50Hz/1Phase
Running Amps	12.0
Circuit Protection Amps	20
Wire Size	12 gauge
Electrical Service	3 wire + ground

Shipping Weight	950 lbs.	351 kg.
Net Weight	850 lbs.	311 kg.
Clearance Behind Machines (min.)	18"	457 mm.

Section 2: Installation & Operation

Installation and Operation

All commercial dryer installations must conform with local applicable local codes or in the absence of local codes, with the National Fuel Gas Code ANSI Z223.1A-1988. Canadian installations must comply with current standard CAN/CGA-B149(.1 or .2) Installation Code for Gas Burning Appliances or Equipment, and local codes if applicable. The appliance, when installed, must be electrically grounded in accordance with the National Electric Code, ANSI/NFPA No. 70-1990, or when installed in Canada, with Standard CSA C22.1 Canadian Electrical Code Part 1.

Installation Clearances:

This unit may be installed at the following alcove clearances.

1. Left side- 0"
2. Right side- 0"
3. Back- 18" (Certified for 6" clearance: however 18" is required to clean, service, and maintain the dryer).
4. Front- 48" to allow use of dryer.
5. Top- Refer to figure labelled "Vertical Clearance Dimensions".
6. Floor- This unit may be installed upon a combustible floor.

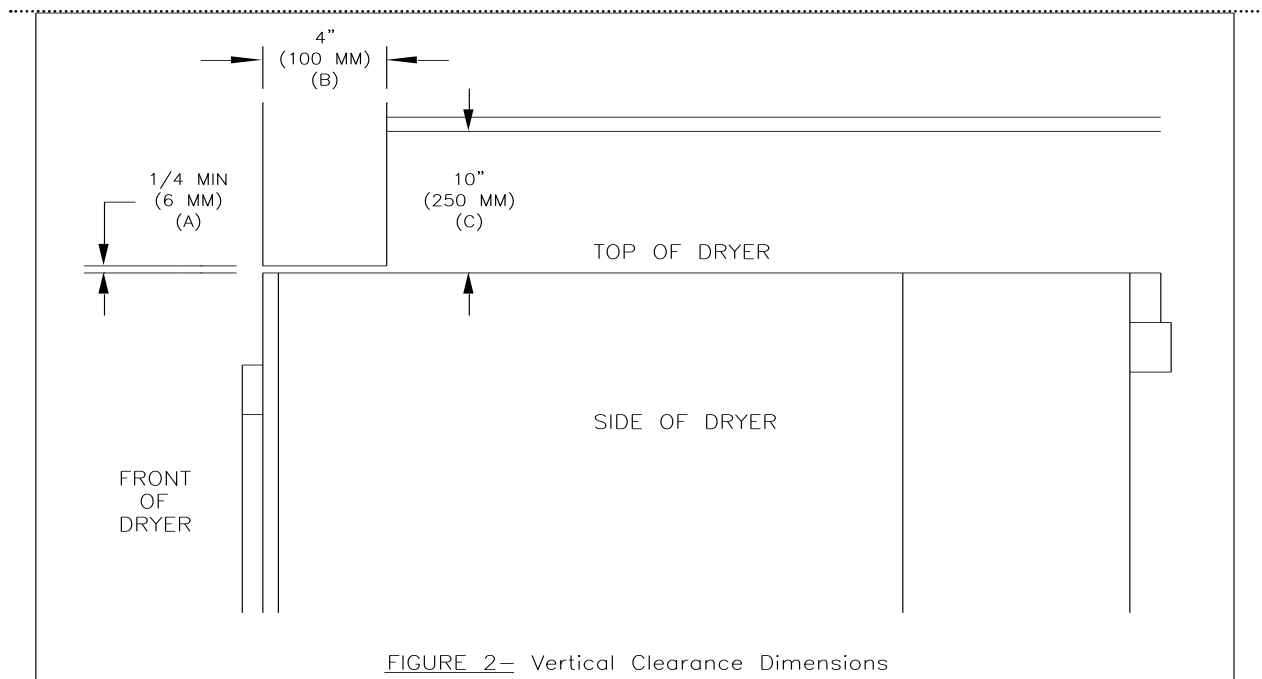

Makeup Air

Adequate makeup air must be supplied to replace air exhausted by dryers on all types of installations. Provide a minimum of 1 1/2 square feet of makeup air opening to the outside for each dryer. This is a net requirement of effective area. Screens, grills or louvers which will restrict the flow of air must be considered. Consult the supplier to determine the free area equivalent for the grill being used.

The source of makeup air should be located sufficiently away from the dryers to allow an even air flow to the air intakes of all dryers. Multiple openings should be provided.

NOTE: The following considerations must be observed for gas dryer installations where dry cleaners are installed. The sources of all makeup air and room ventilation air movement to all dryers must be located away from any dry cleaners. This is necessary so that solvent vapors will not be drawn into the dryer inlet ducts. Dry cleaner solvent vapors will decompose in contact with an open flame such as the gas flame present in clothes dryers. The decomposition products are highly corrosive and will cause damage to the dryer ducts and clothes loads.

Electrical Requirements

The electrical power requirements necessary to operate the unit satisfactorily are listed on the serial plate located on the back panel of each dryer. The electrical connection should be made to the terminal board, on the rear of the unit, using #10 AWG wire for 120V, #12 AWG for 208-240V.

It is absolutely necessary that the dryer be grounded to a known ground. Individual circuit breakers for each stacked dryer are required. Use 30A circuit breakers for 120V and a 20A circuit breakers for 208-240V. This dryer is adjusted for 120V as shipped. Conversion instructions to 208-240V are at the end of this booklet.

Gas Requirements

The complete gas requirements necessary to operate the dryer satisfactorily are listed on the serial plate located on the back panel of the dryer. The inlet gas connection to the unit is 1/2 inch pipe thread. However, the size of the piping to supply the dryer should be determined by reference to the Fuel Gas Code and consulting the local gas supplier.

A joint compound resistant to the action of liquefied petroleum gases should be employed in making pipe connections. A 1/8 inch NPT plugged tapping, accessible for test gage connection, must be installed immediately upstream of the gas supply connection to the dryer.

A drip tee is provided in the unit gas piping to catch dirt and other foreign articles.

All pipe connections should be checked for leakage with soap solution or leak detector. Never check with an open flame.

CAUTION: The dryer and its individual shutoff valve must be disconnected from the gas supply piping system during any pressure testing of that system at test pressures in excess of 1/2 psig. The dryer must be isolated from the gas supply piping system by closing its individual manual shutoff valve during any pressure testing of the gas supply piping system at test pressures equal to or less than 1/2 psig.

Burner Set-Up

All gas burner manifolds should be checked for proper gas pressure while burning. Stack dryer burners should be set at 3.5 W.C. while burner operating.

Exhaust Installation

Exhausting of the dryer should always be planned and constructed so that minimum air restrictions occur. (Refer to Figure on dryer exhausting). Maximum static back pressure allowed at rear exit of dryer is .3 SBP.

Any restriction due to pipe size or type of installation can cause slow drying time, excessive heat, and

lint build up in system and the room.

From an operational standpoint, incorrect or inadequate exhausting can cause cycling of the high limit thermostat which shuts off the main burners and results in inefficient drying.

Individual exhausting of the dryer is recommended. All heat, moisture, and lint should be exhausted outside by attaching a pipe of the proper diameter to the dryer adapter collars and extending it out through an outside wall. This pipe must be very smooth on the inside, as rough surfaces tend to collect lint which will eventually clog the ducts and prevent the dryer from exhausting properly. All elbows must be smooth on the inside. All joints must be made so the exhaust end of one pipe is inside the next one downstream. The addition of an exhaust pipe tends to reduce the amount of air the blower can exhaust. This does not affect the dryer operation if held within practical limits. For the most efficient operation, it is recommended that no more than 14 feet of straight 6" diameter pipe with two right angle elbows be used for each cylinder. When more than two elbows are used, two feet of straight pipe should be removed for each additional elbow. No more than two right angle elbows should be used to exhaust each cylinder.

If the exhaust pipe passes through a wall, a metal sleeve of slightly larger diameter should be set in the wall and the exhaust pipe passed through this sleeve. This practice is required by some local codes and is recommended in all cases to protect the wall. This type of installation should have a means provided to prevent rain and high winds from entering the exhaust when the dryer is not in use. A hood with a hinged damper can be used for this purpose. Another method would be to point the outlet end of the pipe downward to prevent entrance of wind and rain. In either case, the outlet should be kept clear by at least 24" of any objects which would cause air restrictions.

Never install a protective screen over the exhaust outlet.

When exhausting a dryer straight up through a roof, the overall length of the duct has the same limits as exhausting through a wall. A rain cap must be placed on top of the exhaust and must be of such a type as to be free from clogging. The type using a cone shaped "roof" over the pipe is suitable for this application. Exhausting the dryer into a chimney or under a building is not permitted. In either case there is a danger of lint buildup which can be highly combustible.

Installation of several dryers where a main discharge duct is necessary, will need the following considerations for installation. Whether using the 8" exhaust kit or individual 6" ducts, entrance into the main discharge duct should be at a 45 degree angle in the direction of discharge air flow.

NOTE: A small diameter duct will restrict air flow, a large diameter duct will reduce air velocity, both contributing to lint build up, An inspection door should be provided for periodic clean-out of the main duct.

NOTE: STATIC BACK PRESSURE should be a maximum of 0.3 in. w.c (7.6 mm w.c) at the rear exhaust outlet of the dryer. If multiple dryers are connected to the common duct, ensure the back draft damper is installed properly.

NOTE: The following illustration shows the various round main duct diameters to use with the individual dryer ducts. The main duct can be rectangular or round, provided adequate air flow is maintained. For each individual cylinder the total exhausting (main discharge duct plus duct outlet from the dryer) should not exceed the equivalent of 14 feet and two elbows. The diameter of the main discharge duct at the last dryer must be maintained to exhaust end.

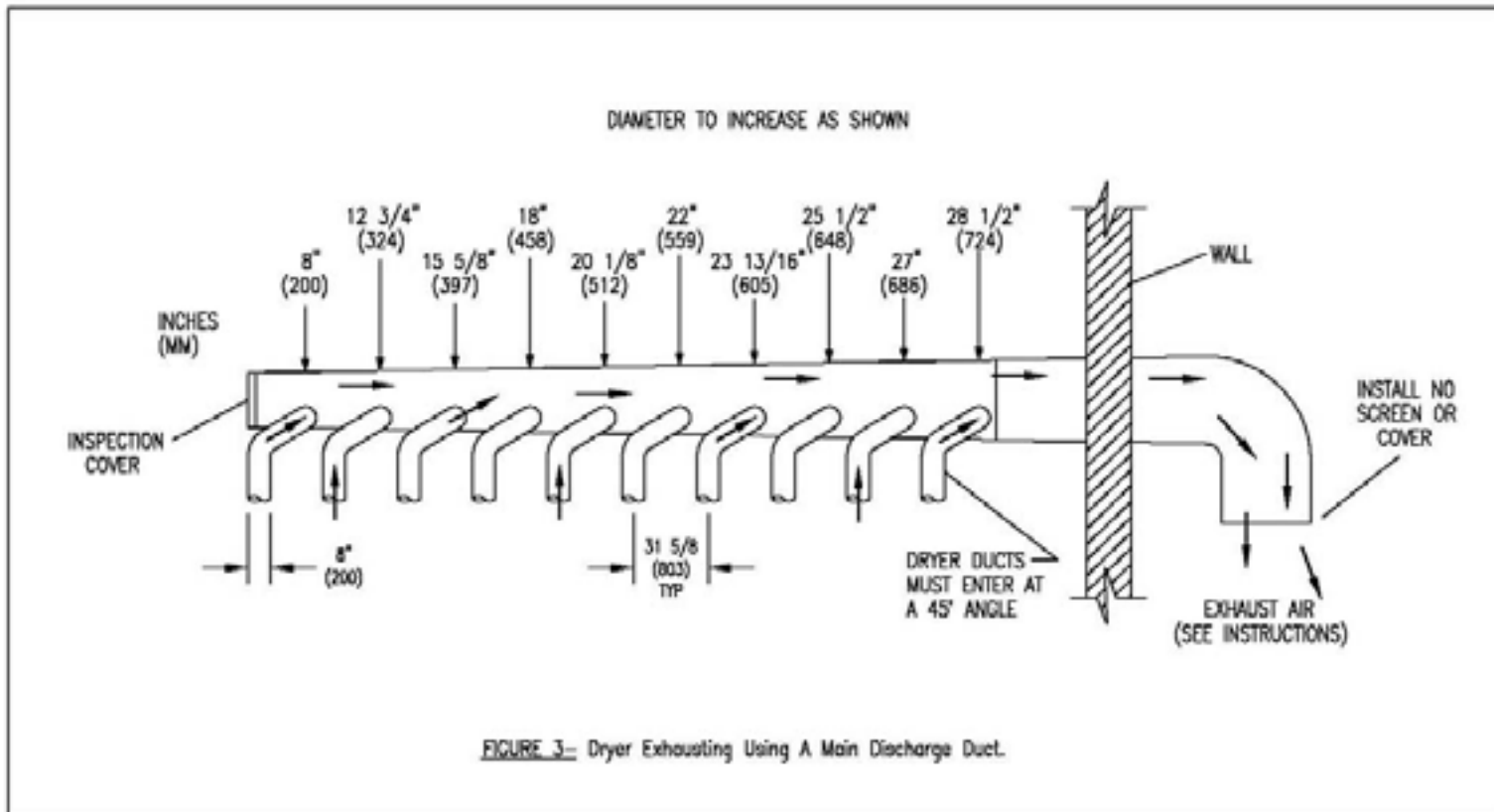

Dexter T-30x2 Stack Dryer Installation Dimensions

DDAD30 COIN STACK DRYER

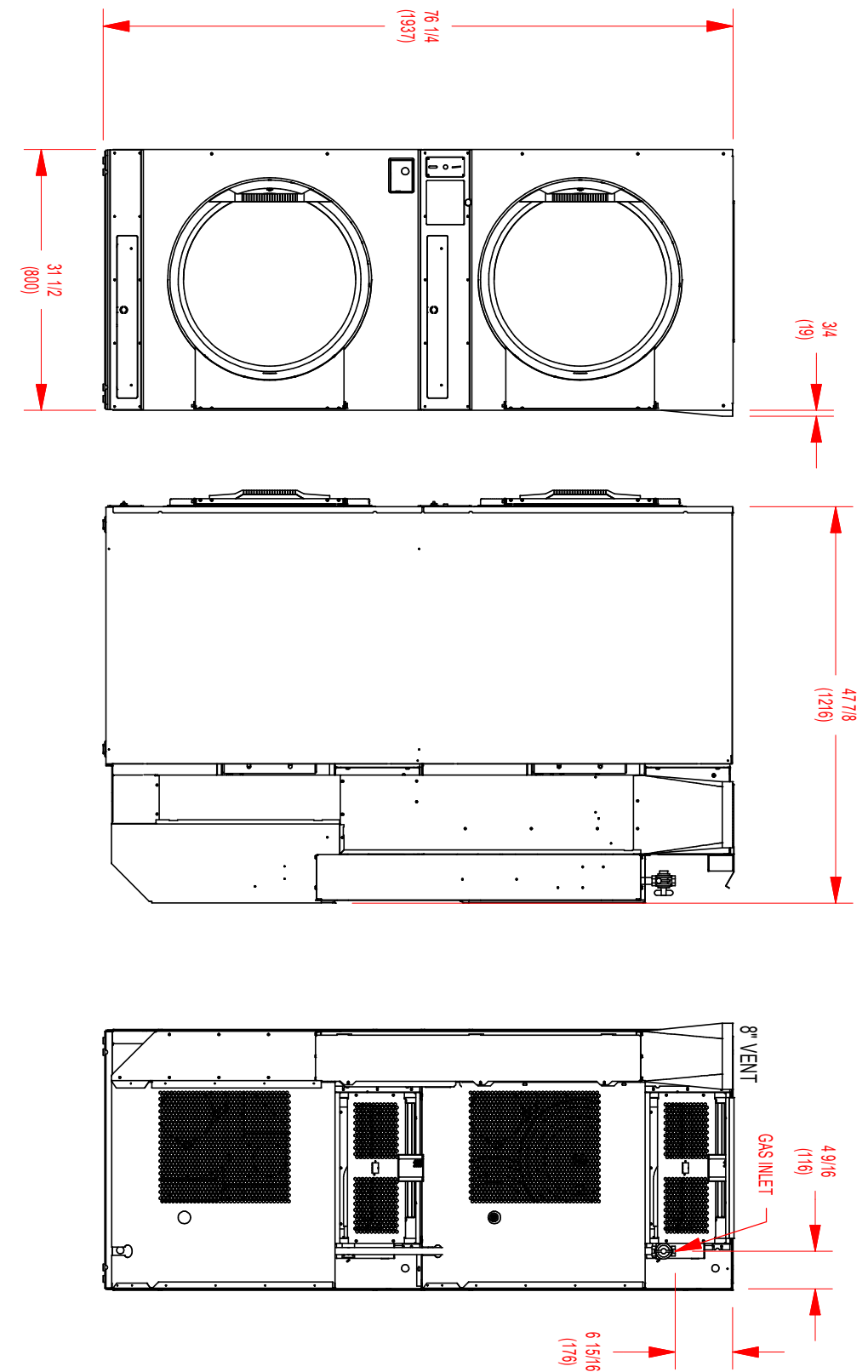

Dryer Operation

Description of Electronic Control

The single electronic control unit controls the coin count, dry time, temperature and information display. The digital display shows vend price when waiting for coins to be inserted and time purchased after coins have been deposited.

When the tumbler is in use, the display shows the number of minutes remaining to be used. The three temperature selection buttons have indicator lights to indicate which temperature selection has been made. At the end of the cycle, the digital display flashes until the operator opens the door to remove the load. Temperature readout is available by pressing the temperature selection button that is in use along with the start button.

Electronic Control Features Available (shown in pictures)

- 1. Anti-Wrinkle**
After a dryer has completed its dry time, the dryer will tumble intermittently without heat, until the door is opened. This is to reduce wrinkling of the clothes. This feature may be selected by removing a jumper from the electronic control.
- 2. Last Temperature Used**
After a dryer has completed its dry time, the temperature that was being used will be selected for the next use, unless the new user selects a different one. This feature may be selected by removing a jumper from the electronic control.
- 3. Battery Back-up**
All programmed and dry time remaining data are protected from power interruption by battery back-up.

Operating Instructions

1. Load clothes into the tumbler and close the door.
2. Deposit the vend price that is shown in the display.
3. Select the desired temperature. Temperature selection may be changed at any time during the cycle.
4. Push the start button to start the dryer.
5. Additional time may be purchased as long there is time remaining in the display, even if the amount added is less than the original vend price.

IMPORTANT: Opening the loading door will stop the dryer. However, the computer will continue to count down the time.

Dexter Control Features Activation Procedures



Remove jumper to activate Anti-Wrinkle feature

Battery

Remove jumper to activate Last Temperature Used feature

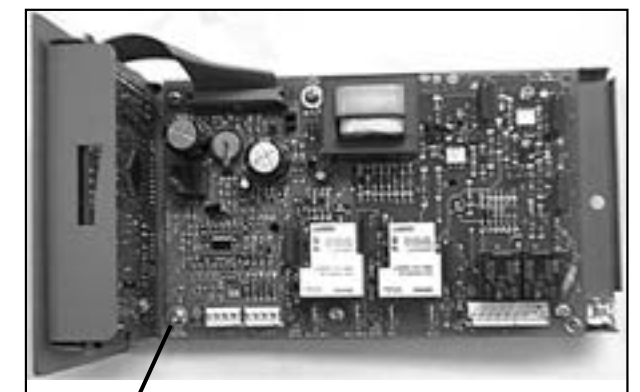
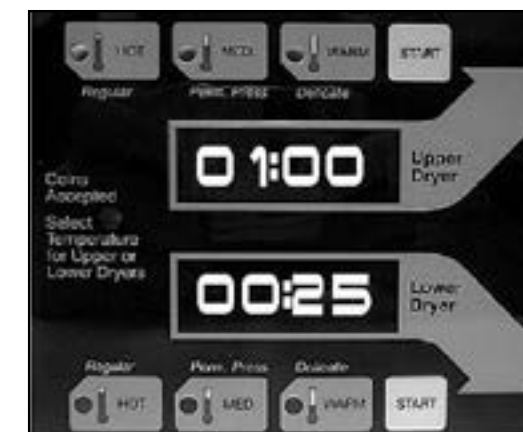
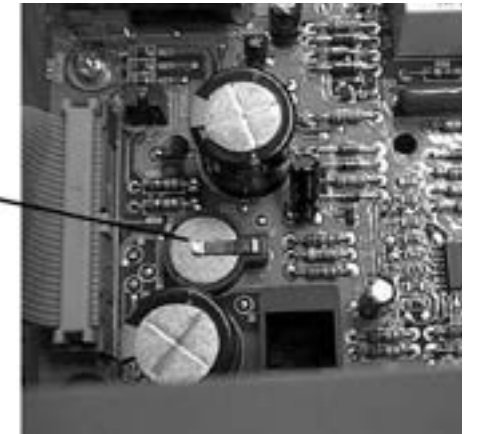

Program Button

Changing Programmed Data

Entering Program Mode

The controller is put into the programm.ing mode by opening both dryer doors and pushing the program switch (shown in a previous picture) on the back of the controller circuit board. The switch is accessed by unlocking the controller and sliding it out just enough to reach the switch.

Programming

The upper display shows the setting for each step of the program as you go through the list.

The lower display gives the number of the program step as given on the previous program step chart (00-18).

The lower "Hot switch" will advance the controller through the nineteen steps which can be observed or altered. Each step can be identified by the step number in the lower display.

The upper and lower "Start switches" increase and decrease the values in the upper display by the increments given in the program step chart.

The lower "Perm press" switch will return the value for the step being displayed to the original value given on the program step chart. Note: For the hour meter and the money audit steps this value is zero.

Exiting Program Mode

The controller remains in the programm.ing mode until one of the following happens:

1. The mode switch is pushed again.
2. The eighteenth and last step of the programm.ing sequence is completed (first step is 00, last step is 18) and the step switch is pushed following this step.
3. Programm.ing is stopped for approximately one minute.
4. The dryer doors are closed.

Programming Example

For an example we will change the vend price from \$.25 to \$.50.

Step

1. Open upper and lower loading doors.
2. Unlock the control tray and carefully slide it about 3 inches out of the machine. Press the program switch behind the vertical portion of the circuit board. Replace and relock the control tray in its original position.
3. Consult program chart to find vend price as step 09. Push lower "Hot" button to advance through steps until 09 is displayed in lower display. Current vend price (25 in this case) will be displayed in upper window.
4. Push upper start button to increase price by increments of 1 until 50 is reached and shows in the upper display.

NOTE: To make any change it is necessary after changing the value to press the lower "Hot" and advance one more step in order for the new value to be entered into the computer memory.

5. Exit the program mode by any of the methods previously mentioned.
6. The displays should now show "50" as the price to start the machine.

PROGRAMMED DATA

Adjustable parameters are vend price, temperatures, and cool-down times. Hours run and money count information can be displayed and these registers are resettable to zero.

There are nineteen programming steps. These nineteen steps are: (all temperatures are degrees Fahrenheit).

STEP	DESCRIPTION	RANGE	INCREMENTS	SETTINGS
00	Lower drum hour meter	0 to 9999 hr.	—	0
01	Upper drum hour meter	0 to 9999 hr.	—	0
02	Left coin audit	0 to \$9999	—	0
03	Right coin audit	0 to \$9999	—	0
04	Hot temp. setting	150-190	5	175
05	Medium temp. setting	120-170	5	150
06	Warm temp. setting	110-150	5	125
07	Left coin input	0-100	1 cents	10
08	Right coin input	0-100	1 cents	25
09	Vend price	0-999	1 cents	25
10	Time left coin	0-99:55 minutes	1 sec.	3:20
11	Time right coin	0-99:55 minutes	5 sec.	8:00
12	Time for free vend	0-99:55 minutes	5 sec.	8:00
13	Cool down time Hot cycle	0-10:00 minutes	5 sec.	2:00
14	Cool down time Medium	0-10:00 minutes	5 sec.	2:00
15	Cool down time Warm cycle	0-10:00 minutes	5 sec.	2:00
16	Temperature Type display	Centigrade or Fahrenheit	C or F	F
17	Decimal Point		On or Off	On
18	Seconds Display		No or Yes	No

Section 3: Wiring Schematics

Dryer Idle - No Coins Added

Top Dryer Used For This Example

120VAC is supplied to the Electronic Control (computer board) by L1 on the black wire. This tells us that any time there is power to the dryer that the Computer Board will be powered with and the display lighted. 120VAC also goes to one side of the door switch on a black wire. Closing the loading door sends 120VAC to the Computer Board on two blue wires. One blue wire makes 120VAC available to one side of the Motor Run Relay R1. On the computer the other blue wire provides a 120VAC signal to the Computer Board telling it that the door is closed. The door light on the computer board should be illuminated when the door is closed.

Coins Added - Motor Starting and Running

Top Dryer Used For This Example

As each coin is added the Coin Switch closes and completes a circuit to the Computer Board. The Computer Board counts these signals and when the correct number of coins are counted the Computer Board closes the Motor Run Relay on the computer. With this Relay closed, 120VAC is supplied to the Motor Relay on the red wire. The motor light on the computer board should be illuminated anytime the computer calls for the motor to operate. The Motor Start Switch is drawn in the start position. In this position the incoming power is supplied directly to the main run winding and through the Start Capacitor to the Auxiliary Winding (start winding). As the Motor comes up to speed, the switch opens the circuit to the Start Winding and closes the circuit to the Gas Relay. This kicks the Start Winding out of the circuit and provides power to the Gas Relay on the violet wire. The heat circuit in the dryer can not operate if the motor is not running. The gas LED on the computer board should be illuminated after the Motor LED is on and the computer determines if gas is necessary to satisfy temperature requirements.

Heat Circuit

Top Dryer Used For This Example

With the Drive Motor running, 120VAC is provided to the Gas Relay on the violet wire from the motor. This violet wire connects and changes to an orange wire out of the Gas Relay. The gas light on the computer board should be illuminated anytime the computer calls for the heat. The Computer Board closes the Gas Relay Contact providing 120VAC on the orange wire to the High Limit Thermostat. The High Limit Thermostat is normally closed. (It will open, turning off the heat circuit, if the dryer can't move enough air from problems such as an exhaust restriction) 120VAC goes through the normally closed High Limit Thermostat to the normally open Air Switch (Sail Switch) on the brown wire. This switch is closed only if the dryer is running and has the correct air flow. With the dryer running and the Air Switch closed, 120VAC is supplied to the upper overtemp thermostat on the gray wire and changes to the black wire to the gas control transformer. This transformer steps 120VAC down to 24VAC. There is a 1.5 amp in-line fuse that protects the Ignition Controller after the transformer. 24 volts is supplied to the Spark Ignition Module (Ignition Controller) by the Control Transformer on the red wire. The Spark Ignition Module will then send high voltage to the Spark Electrode via the High Voltage Lead (this lead looks like an automotive spark plug wire). The Spark Ignition Module also sends 24VAC to the Gas Valve Coils which open the Gas Valve. When ignition occurs the high voltage sparking stops. If ignition does not occur, the Spark Ignition Module will only spark for 10 seconds. The Spark Ignition Module will try this sequence for 10 seconds in 2 more sequences before locking out.

Over Temperature Thermostat (Manual Reset Safety Shutoff Thermostat)

Top Dryer Used For This Example

This thermostat is manually reset by pushing in the red button. The Over Temperature Thermostat is a safety backup for the entire Heat Circuit and located in the recirculation chamber area on the side of the burner housing. If the dryer overheats this Over Temperature Thermostat it opens the line to turn off the heat but leaves the Computer Board lighted and the drive motor powered and turning so the basket will cool down.

Cool Down

Top Dryer Used For This Example

At the preprogrammed time (2 minutes factory setting - adjustable) the Computer Board will open the Gas Relay Contact. This allows the Drive Motor to continue to run but without heat. The gas light on the computer board should not be illuminated anytime the computer is in cool down. This Cool Down period allows the clothing (zippers, snaps, etc.) time to cool down to a temperature that is easily handled by customers.

End of Cycle

Top Dryer Used For This Example

At the end of the cool down, the Computer Board opens the Run Relay which removes power from the Drive Motor on the red wire. The motor light on the computer board should no longer be illuminated. The Drive Motor stops and the Computer Board display now flashes until the dryer door is opened. Once the door is opened to remove the clothing the display goes back to vend price.

120VAC 60 HZ Wiring Schematic Dryer Idle - No Coins Added :

Top Dryer Used For This Example

Wiring Diagram for DDAD Dryer

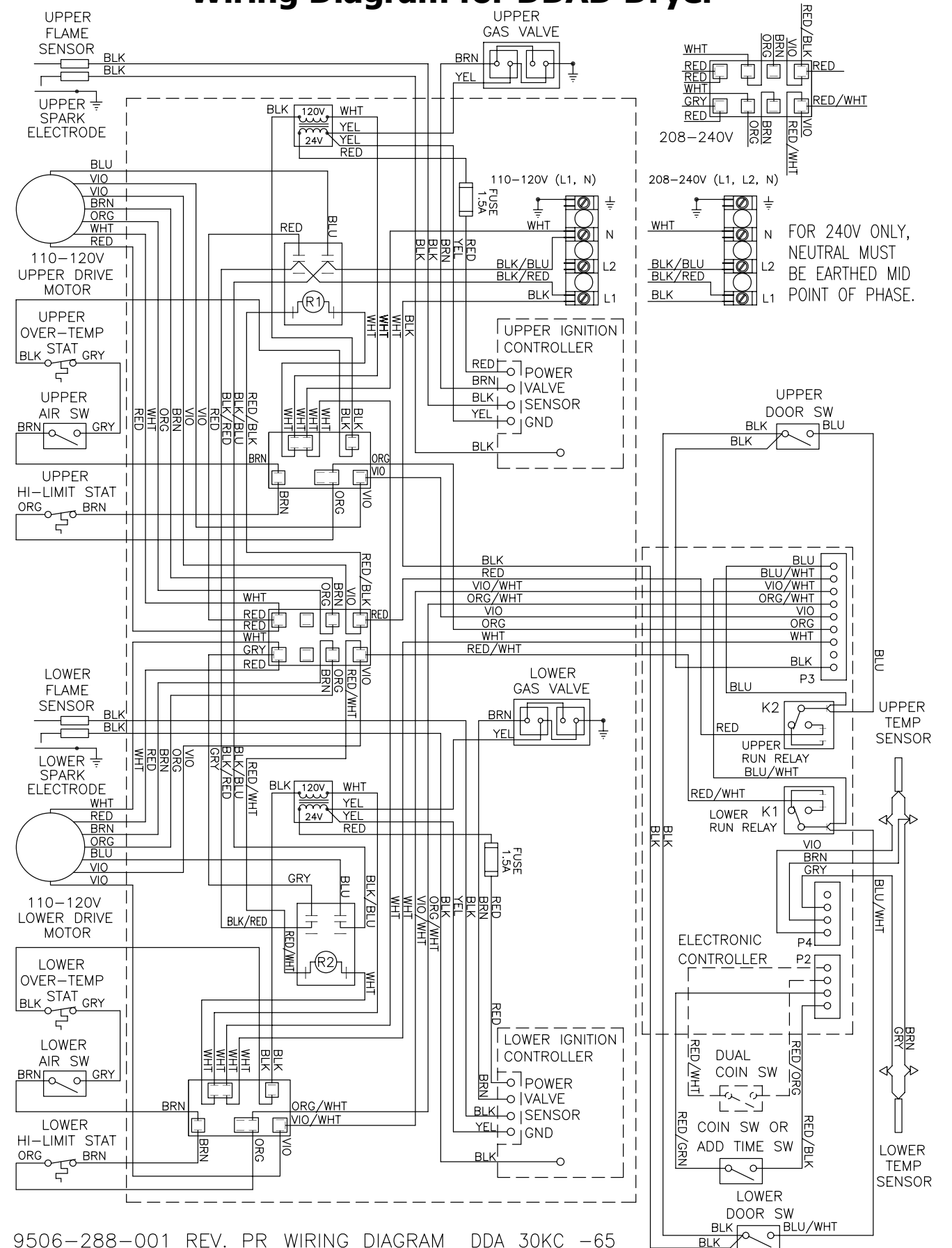

9506-288-001 REV. PR WIRING DIAGRAM DDA_30KC_-65

IMPORTANT: RETAIN THIS ELECTRICAL DIAGRAM FOR SERVICE.

Wiring Schematic for DDAD Dryer

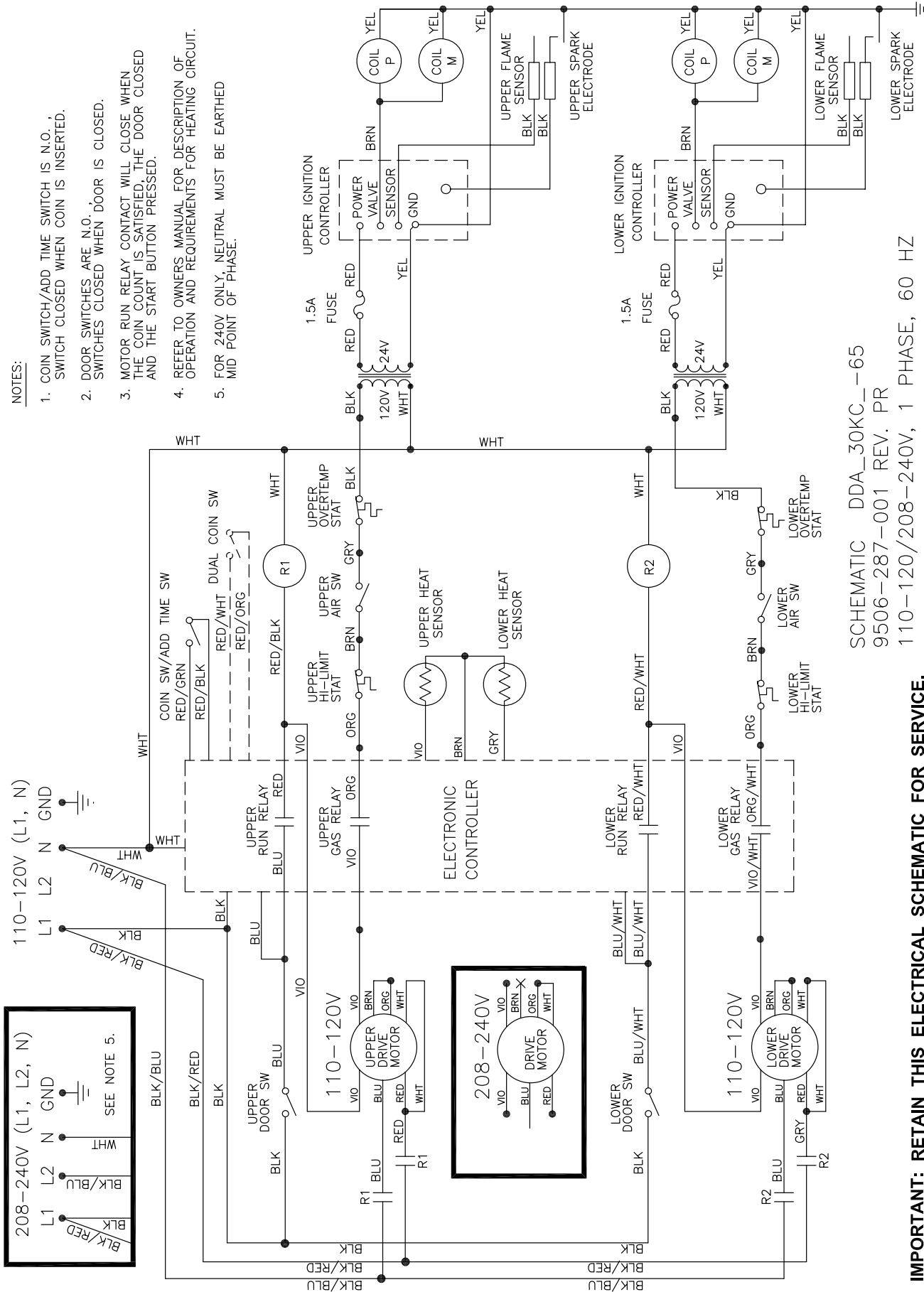

NOTES:

1. COIN SWITCH/ADD TIME SWITCH IS N.O. SWITCH CLOSED WHEN COIN IS INSERTED.
2. DOOR SWITCHES ARE N.O. SWITCHES CLOSED WHEN DOOR IS CLOSED.
3. MOTOR RUN RELAY CONTACT WILL CLOSE WHEN THE COIN COUNT IS SATISFIED, THE DOOR CLOSED AND THE START BUTTON PRESSED.
4. REFER TO OWNERS MANUAL FOR DESCRIPTION OF OPERATION AND REQUIREMENTS FOR HEATING CIRCUIT.
5. FOR 240V ONLY, NEUTRAL MUST BE EARTHED MID POINT OF PHASE.

SCHMATIC DDA_30KC_-65
9506-287-001 REV. PR
110-120/208-240V, 1 PHASE, 60 HZ

IMPORTANT: RETAIN THIS ELECTRICAL SCHEMATIC FOR SERVICE.

Wiring Diagram for DDAD Dryer w/control Protection Fuse

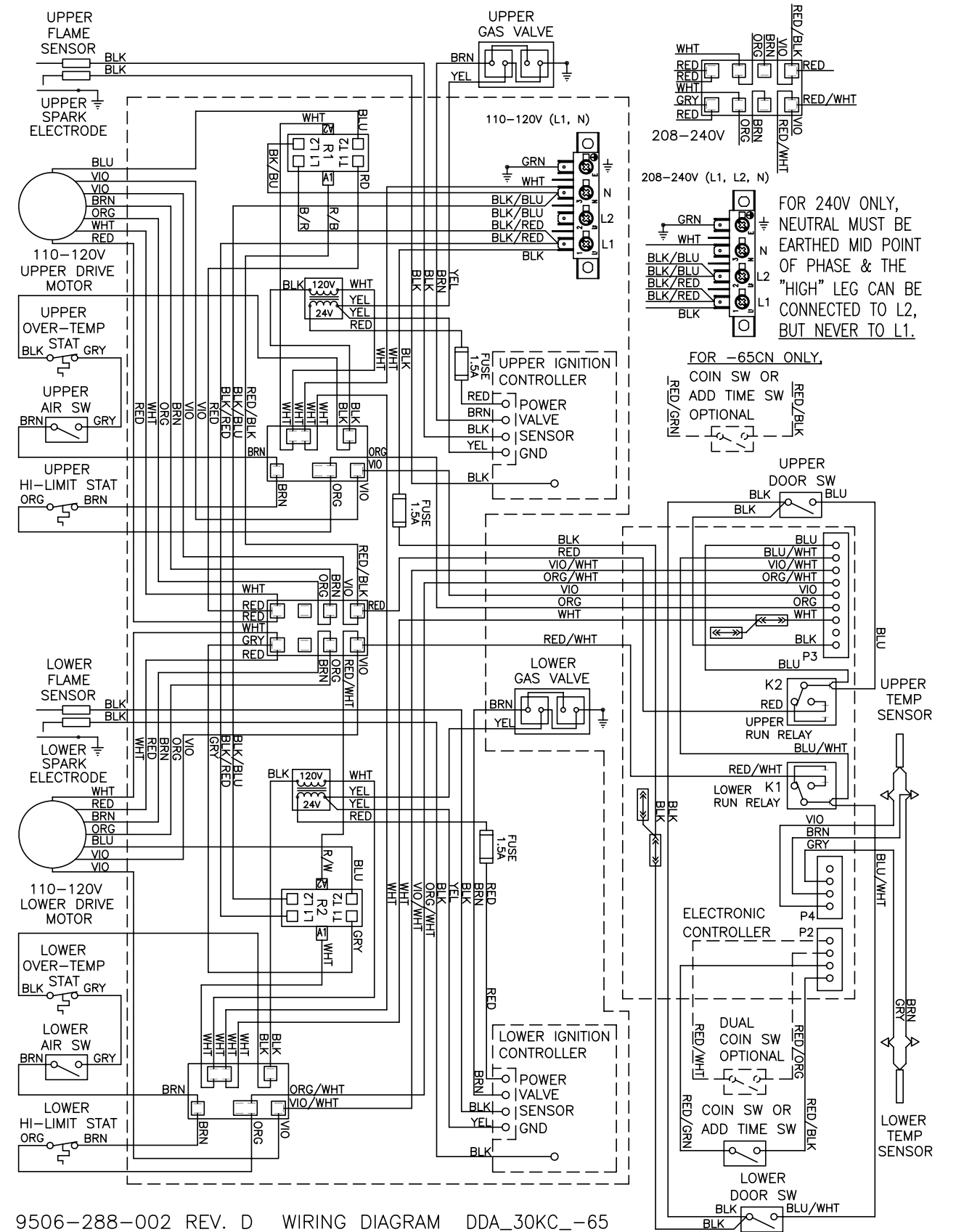

FOR 240V ONLY, NEUTRAL MUST BE EARTHED MID POINT OF PHASE & THE "HIGH" LEG CAN BE CONNECTED TO L2, BUT NEVER TO L1.

FOR -65CN ONLY, COIN SW OR ADD TIME SW OPTIONAL

9506-288-002 REV. D WIRING DIAGRAM DDA_30KC_-65

IMPORTANT: RETAIN THIS ELECTRICAL DIAGRAM FOR SERVICE.

Section 4: Service Procedures

Service Procedures

Clothes Door Removal

1. The clothes door may be removed from the hinge bracket by unscrewing and removing the allen-head pivot screw located at the door upper hinge point.
2. Next lean the door out of the top of the hinge bracket and lift the door from the bottom hinge pin. Note the spacer between the bottom of the door and the hinge.

Clothes Door Latch Adjustment

1. Loosen the lock nut on the latching stud. It is located directly behind the door handle.
2. Open the loading door.
3. Screw the door catch stud in or out as necessary and then retighten the lock nut.

Door Switch Removal And Installation

1. Turn off power to machine.
2. Remove upper lint tray.
3. Unlock Controller.
4. Remove upper door hinge pin and remove door assembly.
5. Remove hinge plate screws and upper right hand screws.
6. Remove two lower left hand screws and loosen upper left hand screw.
7. Pull out right lower corner and remove two wires to switch..
8. Depress tabs and remove switch from the front.
9. To install reverse directions.

Installation Of Clothes Door Window And Gasket

1. Place the clothes door, with its face down, on a solid surface.

NOTE: Prewarming the gasket makes the installation much easier.

2. Install the window gasket on the clothes door flange. The wider lip of the gasket should be on the bottom side or front face of the clothes door and the ridges should be up.
3. Locate the seam at the latching stud.
4. Apply a soapy water solution or rubber lubricant to the gasket.
5. Slide the glass into the middle of the door ring and gasket with half of the glass above the door and half below.
6. While pressing down on the glass, stand the door up and use a modified screw driver with the end rounded off to install half of the glass. Lay the door down and install the other half.
7. At the six o'clock position, pry the glass up enough to install the black spacer. (reuse from old door gasket)

High Limit Thermostat Locations And Functions

A. Burner Housing- This hi-limit is located on the back side of each burner housing.

1. The thermostat opens the circuit to the main burners in the event of malfunction in the gas control area or temperature control. This thermostat will open quickly if there is a significant loss of air flow over the burner area.
2. It is covered by a guard and is held in place by two screws. There are spacers between the thermostat and bracket which must be used to give proper operation.

B. Manual Reset Over temperature Safety Thermostats- The second hi-limit thermostat is located on the right side of each burner housing as you view from the back of the machine. It is just above the gas valve and covered by a guard with a small access hole.

1. The manually resettable thermostat limits the operating temperature a dryer can reach should some abnormal situation occur.
2. Should one of the thermostats be tripped, that particular tumbler will cease to heat until the thermostat is reset. Once the dryer cools, the thermostat may be reset by inserting a pencil or stick through the opening in the thermostat cover.

C. Removal - To remove either the hi-limit thermostat on the rear of the burner housing or the over-temperature thermostat on the right side of the burner housing, remove the mounting screws holding its respective guard. Next, remove the terminal of each wires attached to the thermostat. Lastly, remove the mounting screws holding the thermostat to the burner.

Pressure Regulator Adjustment

Use the following procedure whenever it is necessary to check the pressure regulator setting.

NOTE: Any adjustment of the pressure regulator must be made with a manometer attached at the plug in the main burner manifold.

1. Shut off the gas supply to the dryer.
2. Remove the 1/8" pipe plug from the end of the main burner manifold.
3. Attach a manometer to the manifold end.
4. Remove the pressure regulator cover screw on the gas valve.
5. Open the shutoff valve, and operate the dryer.
6. Adjust the pressure for a manometer reading of 3.5" water column gas pressure. (11.0" for L.P.)

NOTE: The main burners must be operating when adjusting the pressure regulator.

7. Shut off the gas supply to the dryer. Remove the manometer and install the 1/8" pipe plug in the manifold.
8. Open the shut off valve, start the dryer and check for gas leaks while the burners are ignited.

Coin Acceptor Removal

Loosen the four screws (Torx #10 driver) mounting the coin acceptor to its retaining bracket.

Do not remove the screws or the retainer will fall behind the panel.

Shift the acceptor up and down to allow the retainer to slide through the panel opening. When removing, the bottom should be brought through the panel opening first. When reinstalling, the top should go in first.

Coin Switch Adjustment

The coin switch should click soon after the coin hits the operator wire. However there must be enough travel to allow the switch to reset once the coin has passed. Adjustment should be made by bending the wire very close to its attachment point.

Heat Sensor

This unit takes the place of the regulating thermostat on a mechanical timer dryer. The Heat Sensor is a thermistor. The way these work is fairly simple. As the temperature goes up, the resistance in the thermistor (heat sensor) goes down. As the temperature drops, the resistance in the thermistor (heat sensor) goes up.

Electronic Control Diagnostic Lights

The electronic control has 6 diagnostic lights to aid in service of the dryer. Each pocket has indicator lights for

the motor circuit, door switch circuit, and the heat circuit. When the electronic control is carefully unlocked and moved forward these lights are visible on the circuit board. They are each labeled as to function indicated.

1. When either dryer door is closed, the appropriate door light on the computer should be illuminated indicating that the door is closed.
2. When either dryer is running, the appropriate motor light on the computer should be illuminated indicating that the computer is calling for the motor to operate.
3. When either dryer is calling for heat, the appropriate heat light on the computer should be illuminated indicating that the computer is calling for heat.

An example of their function would be troubleshooting an upper dryer pocket that did not heat.

1. Start the machine and insure that it did not heat.
2. Check the upper heat light and see if it is lit.
3. If the heat light is on, this would indicate that the computer was calling for heat and that it was not at fault. You would then go on to check the rest of the heat circuit.

Electronic Control Test Cycle

This test cycle allows the dryer to run for 5 minutes without the need for adding money while servicing. To actuate this 5 minute test cycle leave the loading doors closed, unlock the computer and push the program button on the right front corner of the computer as if you were putting it into the program mode. This will give a 5 minute cycle on both tumblers for evaluating the machine.

Electronic Control Removal

Unlock the retaining lock in the control assembly. Slide the control out of the machine holding the control by the metal tray. There is enough wire length to allow removing the control tray from the machine before disconnecting the wires.

Membrane Switch Replacement

The control buttons are an adhesive membrane switch assembly which may be replaced separately. Slide the control out to gain access to disconnect the ribbon connector. The ribbon connector must be pushed solidly and squarely into its connector when connecting a new membrane switch.

Temperature Sensor Testing

If either tumbler display shows an F1 or F2, that is an indication of possible temperature sensor problems for that tumbler. Before replacing a sensor, check the wires and connections of the sensor for damage. The sensor lead wires are very small and care should be used in routing and connecting them. The sensors are located under the tumblers and may be viewed by removing the lint screen. The temperature sensor should have between 30,000 ohms and 60,000 ohms resistance at room temperature if okay.

Temperature Testing

To check the temperature in the dryer tumbler, press and hold the upper or lower start button for the tumbler being checked and while holding the start button also press the temperature button for the temperature to be checked. The display will read out the current temperature.

Temperature Sensor Removal

UPPER - Remove front panel upper. Once front panel is removed, reach through the right side and back into the area where the sensor is mounted and remove wire nuts to disconnect.

LOWER - To remove the lower temperature sensor it is necessary to remove the lower front panel to gain access to the mounting bracket. Then the bracket is removed as on the upper cylinder.

Upper Front Panel Removal

1. Remove the loading door from the panel.
2. Remove the 3 left side screws, 1 at top right and the 4 right side screws that mount the hinge.

The phillips screw does not have to be removed as it retains the wiring channel to the back of the front panel. The trim does not have to be removed. (The panel may be removed with the door left in place, although it is much heavier and more awkward to do so.)

Lower Front Panel Removal

To remove the lower front panel a procedure similar to the upper may be used. However, the bottom of the upper panel must be loosened and pulled out to allow the upper flange of the lower panel clearance to be removed.

NOTE: Always remove power from the machine before changing drive belts or working with the drive system.

Final Drive Belt Replacement

To replace the final drive belt turn the cylinder slowly by hand and work the belt off of the large pulley.

Motor Drive Belt Replacement

To replace the motor drive belt the final drive belt should be removed as above. Cut the old motor belt and remove. The new motor drive belt fits inside of three of the four motor mounting bolts. To achieve this, remove these three bolts one at a time and slide the belt in past each in turn. In this way the motor is always supported by 3 bolts at any time.

NOTE: All drive belts are self adjusting.

Tumbler Pulley Removal And Installation

Remove the 1 1/2" nut and lock washer. Pull the pulley off the shaft. Watch for the locking key on the tumbler shaft. Upon installation, the tumbler nut should be torqued to 150 ft./lbs.

Note: After Serial #226213 Remove bolt and washers holding pulley to cylinder shaft. Reinsert bolt then using two or three jaw puller Pull pulley straight off of shaft.

Intermediate Pulley And Tension Arm Removal

1. The intermediate pulley is retained with a snap ring. Remove the snap ring and the pulley slides off the shaft.
2. With the pulley off, there is access to the self adjusting tension arm assembly. The tension arm assembly may be removed by removing the snap ring that holds it to the tension arm support assembly pin. The arm assembly is replaced as a complete unit.
3. The grease fitting for the intermediate shaft should be greased monthly.

Tension Arm Support Assembly Adjustment

The tension arm support assembly may be adjusted for alignment of the intermediate pulley and also to

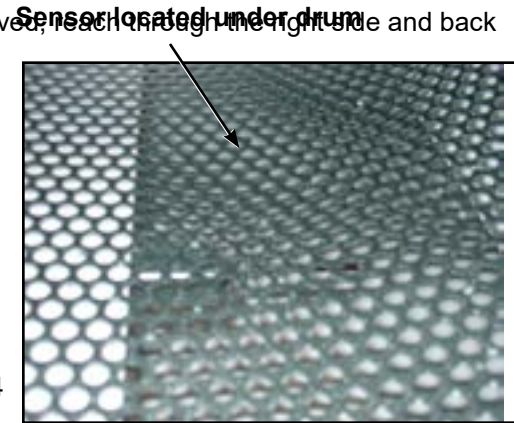

align the belts. The three outer nuts allow the alignment of the pin to be adjusted by pivoting the assembly on the center bolt. The center bolt can be screwed in to allow bringing the complete assembly farther back if necessary for belt alignment.

Motor Blower Assembly Removal And Installation

1. Remove the motor wiring cover and take the 3 motor wires off.
2. Remove the motor wiring cover and take the 3 motor wires off.
3. Remove the 9 nuts and lock washers that retain the blower cover and set assembly out of dryer.
4. The blower is held in place with 2 square headed set screws. Upon reassembly, one blower set screw should fit in the counter sink in the shaft and the other set screw should go against the flat side of the shaft. Use red Loctite on the set screws and torque to 165 in./lbs.
5. The motor is mounted with 4 bolts to the blower cover.

Air Flow Switch Operation And Adjustment

The air flow switch assembly is part of the ignition safety circuit and insures that the burners don't operate unless there is air flow. When the drive motor and blower are running the flat actuator is pulled in against the back of the dryer closing the switch. If this doesn't happen ignition will not occur. The air flow switch assembly is mounted by two screws through the bracket. It can be adjusted by loosening these mounting screws and moving the switch forward or backward.



Ignition Transformer Fuse

The 1 1/2 amp fuse protects the ignition transformer. To remove it just twist and pull it out.

Ignition Control Transformer

When heat is called for, the ignition control transformer steps 120VAC down to 24VAC to power the ignition control.

Electronic Ignition Module

This machine uses an electronic spark ignition system to directly light the burners in each tumbler.

1. The electronic ignition module for each tumbler is located inside the electrical box. This is the metal box on the back of each tumbler area directly to the right of the final drive pulleys.
2. The red wire from the transformer traveling thru the 1.5 amp fuse and into the module supplies the 24VAC required to operate the entire direct ignition system.
3. The black colored hi-voltage wire (spark plug type) plugs onto the post connector on the module, and the multi-wire plug fits into the side of the module.

Spark Ignition Module Removal

1. The spark electrode and sensing electrodes are located directly over the rear burner inside the burner housing.
2. The electrode with the black hi-voltage wire conducts the spark to the center grounding probe, directly over the burner.
3. The electrode with the black sensing wire detects ignition and monitors flame by signaling the module.

NOTE: Proper grounding of the ignition system (yellow wires) is very critical for

proper ignition sequence.

Ignition System-Function & Sequence

During normal dryer operation, the following occurs:

1. The dryer electronic control calls for heat.
2. If the drive motor is running, the motor safety circuit provides power to the electronic control. If the control senses that the heat should be on, a circuit is closed allowing power through the high limit thermostat and air flow switch to the ignition transformer. The transformer provides 24VAC to the ignition module and sparking occurs at the ignition electrode. At the same time 24VAC is applied to the gas valve.
3. Once the flame is established, the sensing electrode detects the presence of flame and the sparking stops.
4. If for any reason the flame is not established in a period of 10 seconds, the electronic control will try this sequence for 3 tries. Normally the 10 seconds "Trial For Ignition" period is ample to establish and prove flame.
5. If the flame is shutdown or blown out during operation, the ignitor will immediately go into "Trial For Ignition" again for 10 seconds.
6. However, at the end of 3 separate retries of 10 seconds "Trial for Ignition", the flame is not established, the ignition system goes into "Safety Lock-Out" and will not reactivate the "Trial for Ignition" until there is a current interruption for a period of 15 seconds. This interruption can be provided by opening the dryer loading door and allowing the machine to come to a complete stop for 15 seconds.

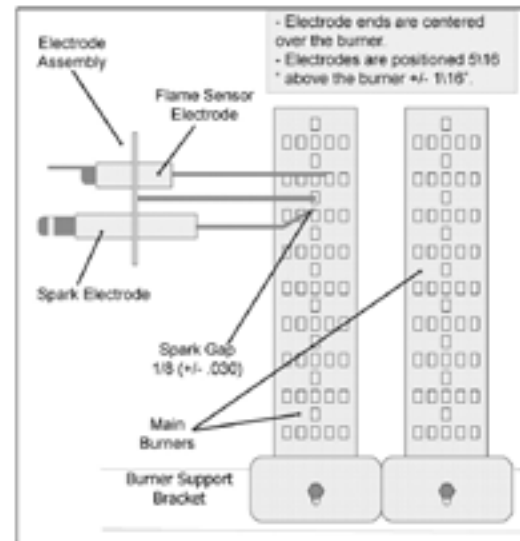

Ignition System-Checkout

1. If flame is present during "Trial For Ignition" period but the system shuts down, there may be an improper ground. The entire ignition system is grounded together including the electrode assembly, the electrode mounting bracket, the burners and the burner bracket. Shutdown can also occur if for some reason the system isn't sensing the flame. Check the sensor for damage and check the connections of the sensor lead.
2. If there is no spark or intermittent spark, check black hi-voltage lead wire for damage or cracks in insulation. (This lead wire must not be taped or connected to any metal edges along its length to prevent pinching and arcing. Also, do not bundle this wire with other wires.)

NOTE: Spark gap and electrode location are important. If the electrode is damaged or mounting is changed the spark gap may not be correct for ignition to occur. Check for cracks in the ceramic insulator. Replace electrode assembly if necessary. Also check for carbon or foreign material on the electrodes and clean if necessary.

Ignition Module Removal

If the ignition modules are mounted on a bracket, see section A. Otherwise, see section B.

With mounting bracket

- A. Remove the connector housing of the wiring harness attached to the ignition module. Then, remove the terminal of the hi-voltage cable attached to the ignition module. Next, remove the mounting screws holding the ignition module mounting bracket in the rear control box. Lastly, remove the nuts holding the ignition module on its mounting bracket.

Without mounting bracket

- B. Remove all of the terminals of the wiring harness attached to the ignition module. Then, remove the terminal of the hi-voltage cable attached to the ignition module. Lastly, remove the mounting screws holding the ignition module in the control box.

Spark Electrode Assembly-Removal

1. Remove electrode cover and disconnect wires to electrodes.
2. Remove two screws to detach electrode assembly.

Gas Valve & Manifold Removal

1. Disconnect union at gas valve and disconnect wires from gas valve operator coils.
2. Remove right manifold mounting bracket screws and slide manifold to remove from left bracket.

Main Burner Orifice Removal

1. Remove manifold and gas valve assembly as above.
2. Using an open end wrench, remove orifices from manifold.

Main Burner Removal

1. Remove the 4 screws securing the cover for the burner housing and the one screw mounting the high limit cover. With the burner housing cover removed, there is complete access to the burner assemblies.

Recirculation Chamber Inspection

1. Remove Resettable manual overtemp sensor and remove inspection plate in burner chamber between main burners and rear back panel of dryer.

Cylinder Removal

1. Remove the front panel in front of the cylinder.
2. Remove drive belt, pulley, and key from cylinder shaft.
3. Pull the cylinder from the front of the machine.

Adjustment Of Cylinder Assembly With Front Panel Removed

Section 5: Troubleshooting

Trouble Shooting

Electronic Control Diagnostic Lights

The electronic control has 6 diagnostic lights to aid in service of the dryer. Each pocket has indicator lights for the motor circuit, door switch circuit, and the heat circuit. When the electronic control is carefully unlocked and moved forward these lights are visible on the circuit board. They are each labeled as to function indicated.

1. When either dryer door is closed, the appropriate door light on the computer should be illuminated indicating that the door is closed.
2. When either dryer is running, the appropriate motor light on the computer should be illuminated indicating that the computer is calling for the motor to operate.
3. When either dryer is calling for heat, the appropriate heat light on the computer should be illuminated indicating that the computer is calling for heat.

An example of their function would be troubleshooting an upper dryer pocket that did not heat.

1. Start the machine and insure that it did not heat.
2. Check the upper heat light and see if it is lit.
3. If the heat light is on, this would indicate that the computer was calling for heat and that it was not at fault. You would then go on to check the rest of the heat circuit.

Electronic Control Test Cycle

This test cycle allows the dryer to run for 5 minutes without the need for adding money while servicing. To actuate this 5 minute test cycle leave the loading doors closed, unlock the computer and push the program button on the right front corner of the computer as if you were putting it into the program mode. This will give a 5 minute cycle on both tumblers for evaluating the machine.

Trouble Shooting Fault Codes

- F1 Shorted sensor or shorted sensor wire harness
- F2 Open sensor or sensor wire harness disconnected
- F3 Possible grounding problem. Try powering down and repowering and then push programming button to start dryer. Try resetting with Palm Pilot (extra utilities file). If no success. Try removing battery and reinstall battery.
- F4 Micro Chip Problem. Replace controller.
- F5 Microchip Electrical Problem. Remove power for 1 minute and then power on. Try removing battery and reinstalling on control PCB/

TROUBLESHOOTING TIPS

Symptom	Probable Cause	Suggested Remedy
Tumbler does not turn	Drive belts	Check both drive belts. Replace if failed.
	Drive motor	Check capacitor and motor. Replace if failed
	Door switch	Check door switch contacts and adjustment. Adjust or replace door switch.
	Electronic Control	Is electronic control closing motor relay to power drive motor? Check for motor light on electronic control. If no light change control. If light is on, check voltage and wiring to motor.

Symptom	Probable Cause	Suggested Remedy
Tumbler turns but no spark at burner	Glass fuse	Check small glass control fuse in back of dryer. Replace if failed.
	Temperature Sensor	The temperature sensor should have between 30,000 ohms and 60,000 ohms resistance at room temperature if okay. Replace if not in this range.
	Ignition	Check for 24VAC output from transformer.
	Transformer	Replace if have 120V between black & white and no 24V between red and yellow.
	Over temperature	Check to see if manually resettable thermostat. Thermostat is kicked out. Reset by pushing red reset button.
	Ignition control	Check for 24VAC coming into the control on the at burner red wire. If voltage, then check for 24VAC out on the brown wire. Also check for spark at the ignitor. If no 24VAC output or no spark to the ignitor, replace ignition control.
	Air Flow Switch	Check air flow switch to be sure it closes when dryer is running. If not, adjust or replace switch.
	Hi-limit	Check for continuity. Should be 0 ohms resistance when cold. If not, replace thermostat.
	Gas supply	No gas can cause system lockout
Electronic Control	Is electronic control closing gas relay to power Control heat circuit? Check for gas light on electronic control. If no light change control. If light is on, check voltage and components in heat circuit at transformer at rear of unit.	

Symptom	Probable Cause	Suggested Remedy
Tumbler turns, ignition sparks, no flame	Gas supply	Make sure gas supply is working.
	Gas pressure	Make manometer check of gas pressure. Adjust if necessary.
	Spark Electrode Sensor	Check for damage to electrode or mounting. Replace if necessary.
	Gas valve	Check coil continuity, replace valve if failed.
	Ignition Control	Check for 24VAC to gas valve coils. If no voltage replace ignition control.
Burner Lights, but goes on and off	Electrodes	Check low voltage harness for possible wire break or cuts to allow no signal back to ignition control
Slow drying	Temperature Setting	Check program for correct high temperature setting. Adjust if necessary.
	Air flow restrictions necessary	<ol style="list-style-type: none"> 1. Check lint screen and clean if necessary. 2. Check exhaust for correct length and clean if necessary. 3. Check exhaust damper to insure that it opens when dryer is running and closes when dryer is not in use. 4. Check makeup air to insure that it is adequate. Increase makeup air if necessary. 5. Check static Back pressure no more than .3
	Temperature Sensor	The temperature sensor should have between 30,000 ohms and 60,000 ohms resistance at room temperature if okay. Replace if not in this range.

Symptom	Probable Cause	Suggested Remedy
Erratic display	Initial Start-up	If erratic on initial start-up, leave power on for approximately one hour and check machine operation again.
	Grounding	Machine must be grounded by separate conductor back to neutral bar in breaker box.
	Program	Check program and make corrections if necessary.
	Voltage spike	Power down machine for 20 seconds and repower. If no improvement, replace control.
Manual overtemp Tripping Frequently	Recirculating chamber Lint Accumulation	Remove manual overtemp thermostat and inspect in chamber for excessive lint build up. Access also gained to this chamber by removing recirculation duct mounted at bottom of chamber, or the panel inside burner chamber between burners and rear back panel
	Exhaust ducting Excessive lint buildup	Remove exhaust duct at rear of dryer and inspect for excessive lint build up in complete duct from dryer to where duct exits building.
	Clean lint of of top heat air chamber above tumbler	Remove front panel completely. Be careful of any wiring attached. Remove heated air chamber cover and clean above tumbler back to burner housing.

Notes

Lined area for notes on page 52.

Notes

Lined area for notes on page 53.

Kits, Assemblies, & Common Parts

Coin Acceptor Components	Part Number
Mechanical Coin Acceptor	9021-001-010
Coin Drop Switch	9732-126-001
Coin Drop Screws	9545-053-002
Retainer, Coin Acceptor	9486-149-001
Loading Door Components	Part Number
Door Handle	9244-082-001
Door Close Switch	9539-487-001
Electrical Components	Part Number
Relay, Motor Run (120VAC) (After Serial #217612)	5192-299-001
Relay, Motor Run (120VAC) (Before Serial #217612)	5192-298-001
Transformer, Ignition/Control (120VAC)	8711-011-001
Controls 120VAC (Blue)	9857-147-010
Controls 120VAC (Black)	9857-147-014
Heating Circuit Components	Part Number
Ignition Control Module	9857-116-003
Ignition Electrode Assembly	9875-002-003
Thermostat, Hi-Limit	9576-203-002
Thermostat, Overtemp	9576-207-008
Fuseholder	9200-001-002
Fuse 1.5 amp	8636-018-001
Fuse 2.5amp	8636-018-004
Airflow Switch	9539-461-009
Cabinet Components	Part Number
Cleanout Duct Assembly 8"	9973-034-001



Section 6: Parts Data

DDAD30KC -65

Parts Data

Cabinet Group

Key	Part Number	Description	Quantity
*	9960-256-033	Door Assy., Loading Complete-Alm	2
*	9960-256-032	Door Assy., Loading Complete-Wht	2
*	9960-256-034	Door Assy., Loading Complete-SS	2
*	9960-256-035	Door Assy., Loading Complete-Chrome SS/CHR/BLK	2
1	9960-255-008	Door Assy., Loading-SS(ring only)	2
1	9960-255-016	Door Assy., Loading-Chrome(ring only)	2
2	9982-280-215	Plate Assy., Hinge (Alm) No Pin	2
2	9982-280-014	Plate Assy., Hinge (Wht) No Pin	2
2	9982-280-012	Plate Assy., Hinge (SS) No Pin	2
*	9545-012-015	Screw, Hinge to Door	8
*	8640-413-002	Nut, Hinge to Door	8
3	9212-002-003	Glass, Door	2
4	9206-164-009	Gasket, Glass, Gray	2
4	9206-413-001	Gasket, Glass, Black	2
*	9548-117-000	Support, Door Glass	2
5	9206-420-002	Gasket, Outer Rim Gray	2
5	9206-420-003	Gasket, Outer Rim Black	2
6	9244-082-001	Handle, Loading Door	2
*	9545-018-017	Screw, Handle 1/4-20 x 3/8	2
*	9531-033-001	Stud, Door Catch	2
*	8640-413-001	Nut, Hex	2
*	8640-413-003	Nut, Acorn	2
*	9086-015-002	Catch, Loading Door	2
*	8638-190-009	Pop Rivet for mtg. catch	4
*	8641-582-006	Lockwasher	4
*	8640-399-001	Spring Nut	6
7	9989-516-009	Panel Assy., Front- Lower (Alm)	1
7	9989-516-008	Panel Assy., Front- Lower (Wht)	1
7	9989-516-007	Panel Assy., Front- Lower (SS)	1
7	9989-532-003	Panel Assy., Front- Lower (Wht) (LRG Vault From #222035)	1
7	9989-532-001	Panel Assy., Front- Lower (SS) (LRG Vault From #222035)	1
8	9989-516-003	Panel Assy., Front- Upper (Alm)	1
8	9989-516-002	Panel Assy., Front- Upper (Wht)	1
8	9989-516-001	Panel Assy., Front- Upper (SS)	1
*	9545-008-020	Screw, Torx HD 10 x 3/4	14
*	8541-582-019	Lockwasher	6
*	8640-399-001	Nut, Spring	12
10	9544-047-005	Strap, Hinge (Alm)	2
10	9544-047-002	Strap, Hinge (Wht)	2
10	9544-047-007	Strap, Hinge (SS/Gray)	2
10	9544-047-011	Strap, Hinge (Chrome/Black)	2
*	9545-012-028	Screw, Hinge to Panel	8
11	9545-052-001	Screw, Door to Hinge Strap (Special Black Type)	2
*	8641-436-003	Washer, Fiber	2
12	9021-001-010	Acceptor, Coin	1
*	9486-136-001	Retainer, Coin Acceptor	1
13	9545-053-002	Screw	4
*	9732-126-001	Switch (for coin acceptor with extra actuator)	1
*	9472-001-013	Cabinet Touch Up Paint (White)	1
*	8640-413-004	Elastic Stop Nut	

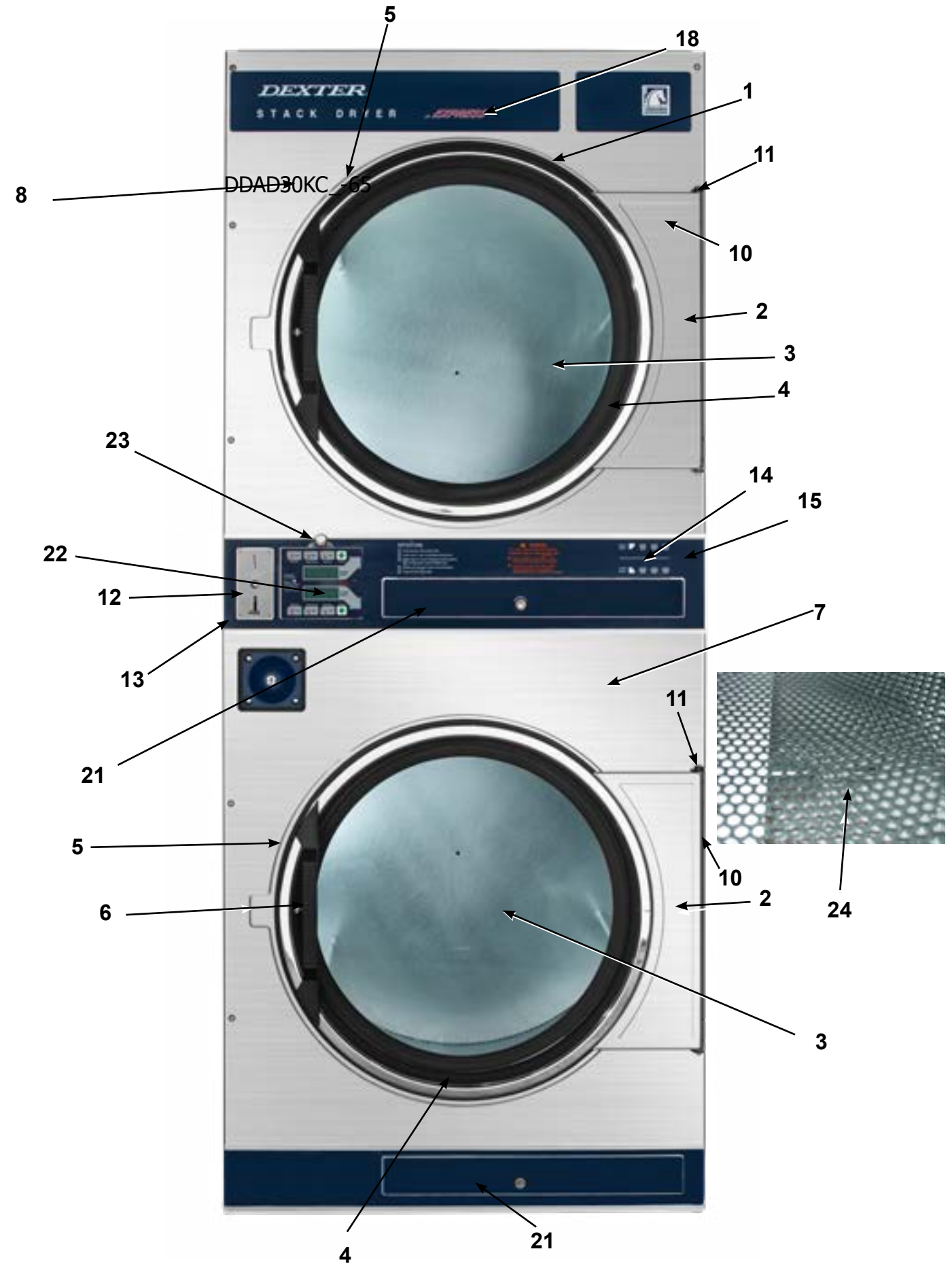

Cabinet Group Continued

Key	Part Number	Description	Quantity
14	9994-030-001	Escutcheon, Upper	1
15	9435-019-001	Trim, Overlay-Upper, Blue.....	1
15	9435-027-001	Trim, Overlay-Upper, Black.....	1
16	9994-031-001	Escutcheon, Lower	1
17	9435-020-001	Trim, Overlay-Lower, Blue.....	1
17	9435-028-001	Trim, Overlay-Lower, Black.....	1
18	9412-154-001	Nameplate Stack Dryer Express, Blue	1
18	9412-167-001	Nameplate Stack Dryer Express, Black	1
21	8650-012-004	Lock and Key, Lint Drawer #6101	2
22	9857-147-001	Controls Assy, Electronic Mounted With Membrane Switch, BLU .	1
22	9857-147-008	Controls Assy, Electronic Mounted With Membrane Switch, BLK .	1
22	9801-059-005	Membrane Switch Assy Blue	1
22	9801-100-001	Membrane Switch Assy Black.....	1
23	8650-012-003	Lock and Key, Control #6324.....	1
24	9501-004-003	Sensor Temp Control (before serial #200588).....	2
24	9501-006-001	Sensor Temp Control (serial #200588).....	2
24	9486-137-002	Retainer - Push On (from serial #200588).....	2
24	9029-169-001	Bracket for Heat Sensor Mounting (Under Basket) before #200588	2
25	9866-004-001	Lint Drawer Assembly, Blue	2
25	9866-004-011	Lint Drawer Assembly, Black	2
25	9435-003-001	Overlay Trim, Lint Drwr- before #201252	1
25	9435-003-009	Overlay trim, lint dwr, after serial #201252, Blue.....	1
25	9435-029-001	Overlay trim, lint dwr, after serial #201252, Black.....	1
*	9545-020-009	Screw	10
*	9532-074-003	Felt Seal (back of lint screen assembly)	2
*	9805-029-002	Lint Screen Assembly ONLY (no front)	2
*	9555-057-002	Replaceable Lint Screen Only	2
*	6292-006-010	Key only #6101.....	2
*	9095-043-001	Cam, Lock Lint Drawer.....	2
*	9545-008-001	Lint Screen Strap Hold Down Screws 10Bx 1/4	32
*	9627-862-001	Harness, Electronic Control	1
*	9627-854-001	Harness Coin Sw	1
*	9095-041-001	Cam, Lock	1
*	6292-006-007	Key 6324 only for Computer	2
*	9627-855-001	Harness, Heat Sensor.....	1
*	9277-041-011	Insulation Cabinet Cover	1
*	9545-045-005	Screw, Round Head (Mounts sensor; phillips head) before #200588...	2
*	9545-008-024	Screw HX Head Tapping (Mounts bracket housing to dryer) before #200588...	2
*	9209-037-002	Grommet, 3/16 ID	2
*	8544-006-001	Leg, Leveling 1/2"	4
*	8545-061-002	Leveling Leg Wrench.....	1
*	9074-261-001	Cover, Cabinet (Top)	1
*	9732-253-001	DDAD Kit for Dryers without Neutral and using 208-240 volt.....	1
*	9732-102-011	LP Kit for DDAD Dryers	1
*	9732-243-001	Stack Dryer Trunion Puller	1
*	9555-057-003	Replaceable Lint Screen Fine Mesh Only.....	1
*	9277-053-001	Insulation-Front Panel-Top Half	2
*	9277-053-002	Insulation-Front Panel-Lower Half	2
*	8640-276-002	Wire Nut Connector Grey.....	4
*	9527-007-002	Standoff Wire Saddle	8
*	9544-041-002	Strap - Bead Tie	1

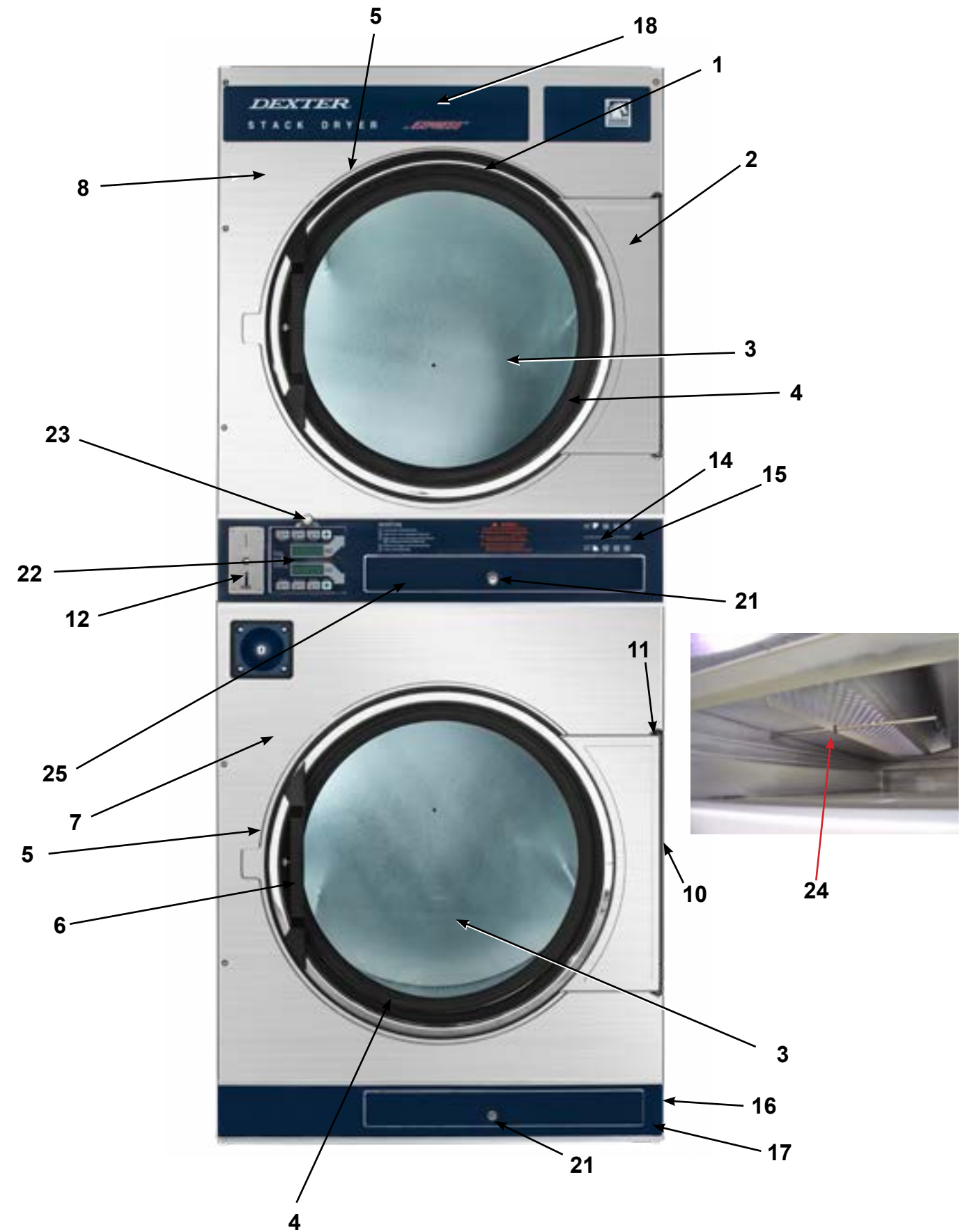

Bearing Housing Group Before Serial #226213

Key	Part Number	Description	Quantity
J1	9241-161-002	Housing, Bearing	2
J2	9036-130-001	Bearing, Ball	4
*	9538-139-002	Spacer, Bearing	2
J5	9545-049-001	Screw, 3/8 x 1.....	4
J6	8640-415-001	Nut, 3/8.....	4
J7	8640-400-002	Nut, 5/16.....	8
*	9803-160-003	Bearing Housing Complete Ass'y (includes bearings,spacer)	2
J4	9545-049-002	Screw 3/8 x 3/4.....	8

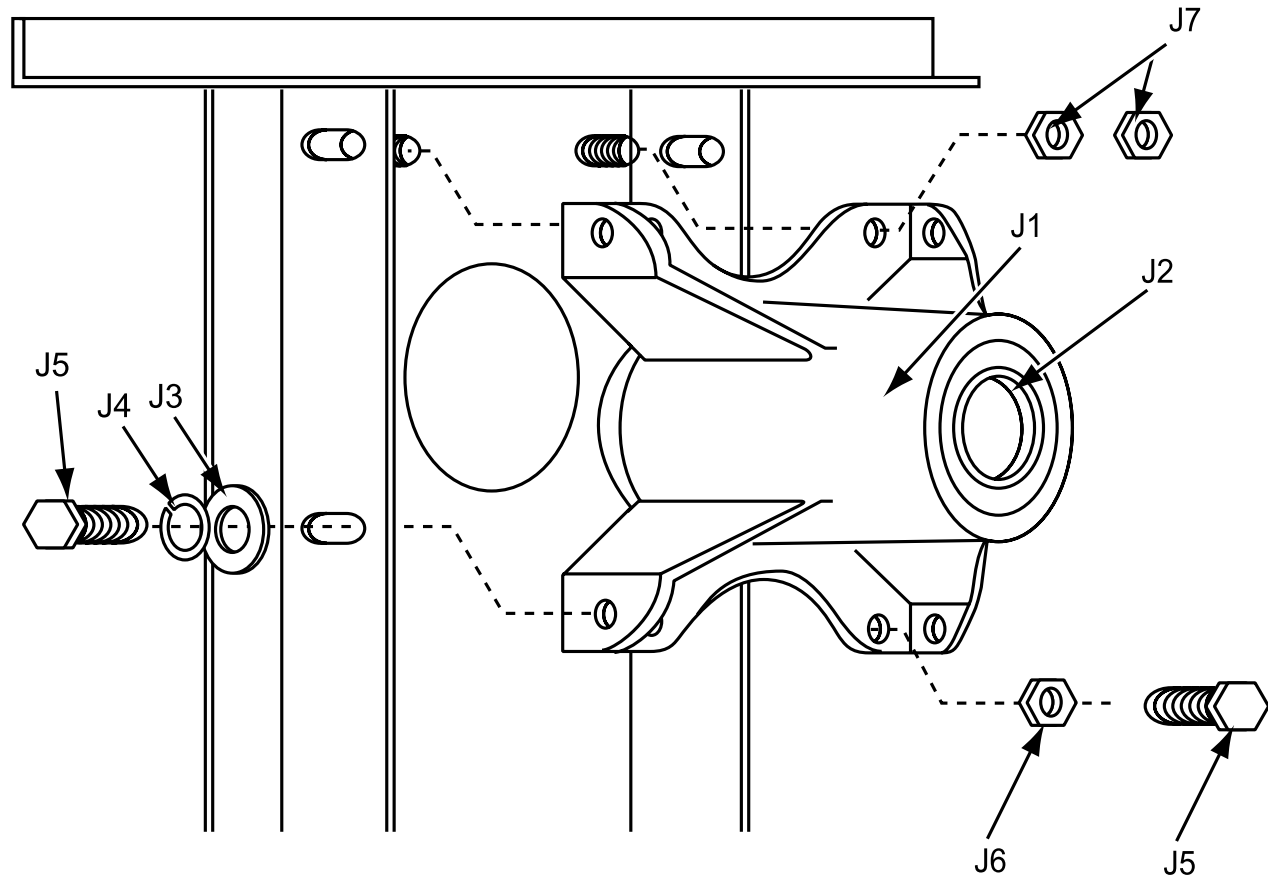

Tumbler Group Before Serial # 226213

Key	Part Number	Description	Quantity
*	9848-127-001	Tumbler Assembly Galvanized w/ Spider.....	2
*	9848-127-002	Tumbler Assembly Stainless w/ Spider.....	2
G2	9568-011-001	Spider Assembly	2
G3	9497-019-003	Rod, Tumbler	6
G4	8640-415-004	Nut-Tumbler Rod, 3/8" - 16.....	6
G6	8641-554-001	Washer, Special	6
G7	9552-013-003	Shim	AR
*	9848-126-002	Tumbler Assembly Stainless Steel Only	2
*	9848-126-001	Tumbler Assembly Galvanized Only	2
G8	8640-222-000	Nut, Tumbler Shaft.....	1

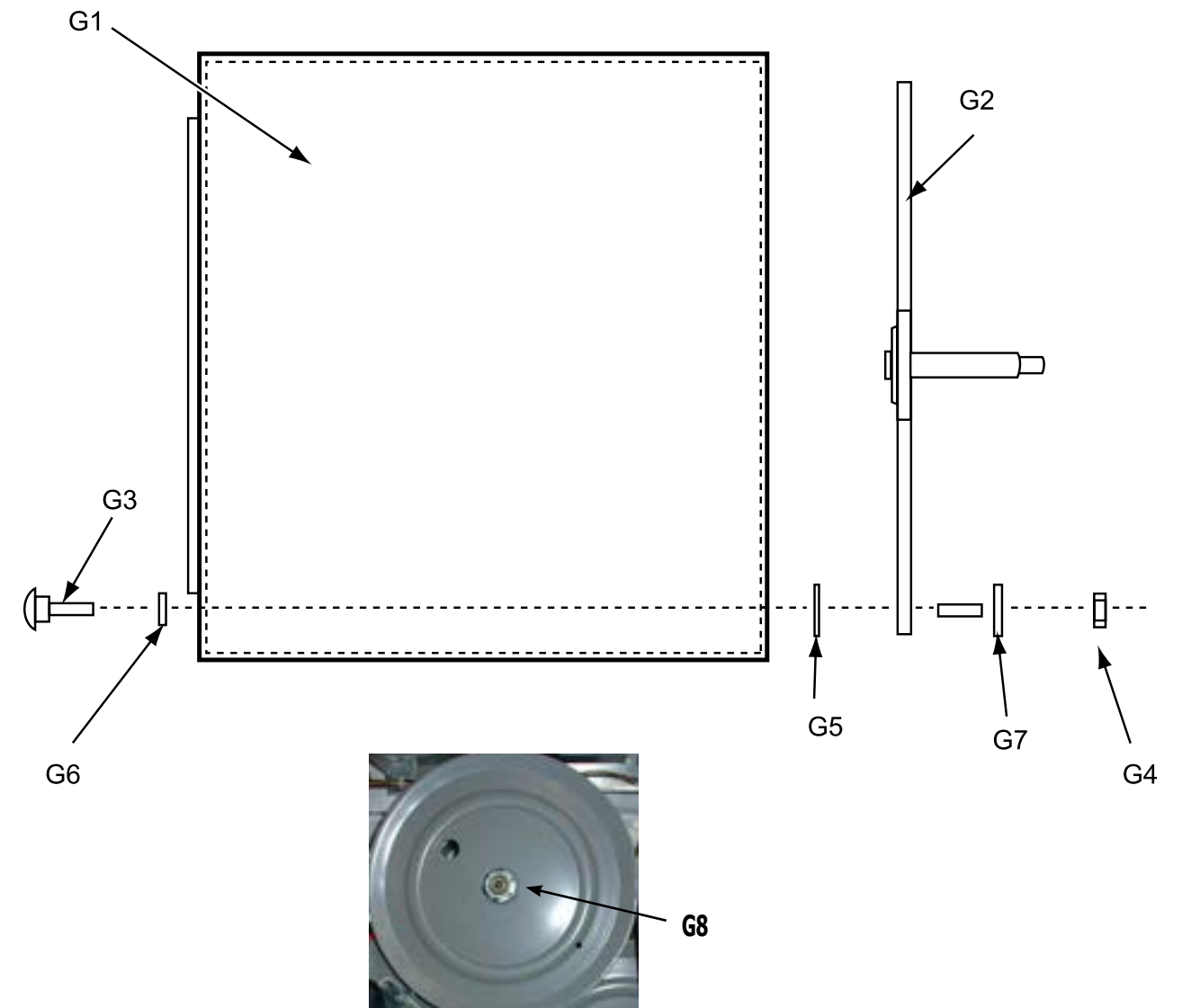

Bearing Housing Group After Serial #226213

Key	Part Number	Description	Quantity
*	9803-160-003	Bearing Housing Complete Assy (Includes bearings & Spacer)	1
1	9241-161-002	Housing, Bearing.....	1
*	9036-130-001	Bearing, Ball, Front.....	1
*	9538-139-002	Spacer, Bearing.....	1
2	9036-130-001	Bearing, Ball, Rear	1
3	9545-049-002	Screw-Wizlock, 3/8-24x3/4.....	4
4	8640-400-002	Nut, 5/16-18.....	4
5	9545-049-001	Screw, 3/8-24x1.....	2
6	8640-415-002	Nut, 3/8-24.....	2
*	9538-139-002	Shim, Tumbler	AR

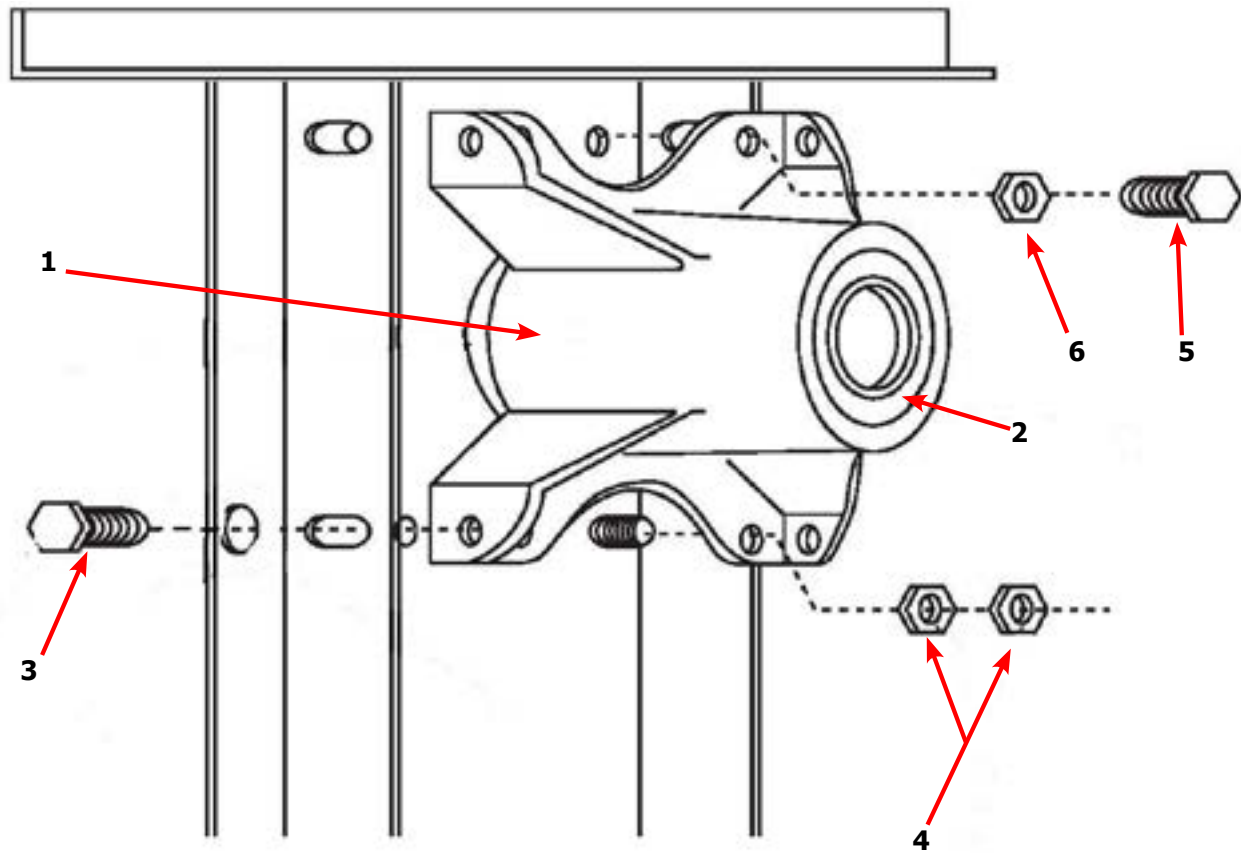

Tumbler Group After Serial #226213

Key	Part Number	Description	Quantity
*	9848-142-001	Tumbler Assy Complete W/Spider (GALV).....	1
*	9848-142-002	Tumbler Assy Complete W/Spider (SS & Galv front)	1
1	9848-126-001	Tumbler Assy (Galvanized).....	1
1	9848-126-002	Tumbler Assy (Stainless Galvanized front).....	1
2	9497-019-003	Rod, Tumbler.....	3
3	8641-554-001	Washer, Special.....	3
4	9552-013-000	Shim	AR
5	9568-015-001	Spider Assy	1
6	8640-415-004	Nut, Wiz Lock	3
7	9538-164-002	Spacer-Shaft	1
8	9487-234-005	Tolerance Ring	1
9	9908-049-002	Pulley, Driven	1
10	8641-581-026	Washer -Flat.....	1
11	8641-582-016	LockWasher - IntTooth, 1"	1
12	9545-017-009	Screw, 1/2-13x1 1/4.....	1

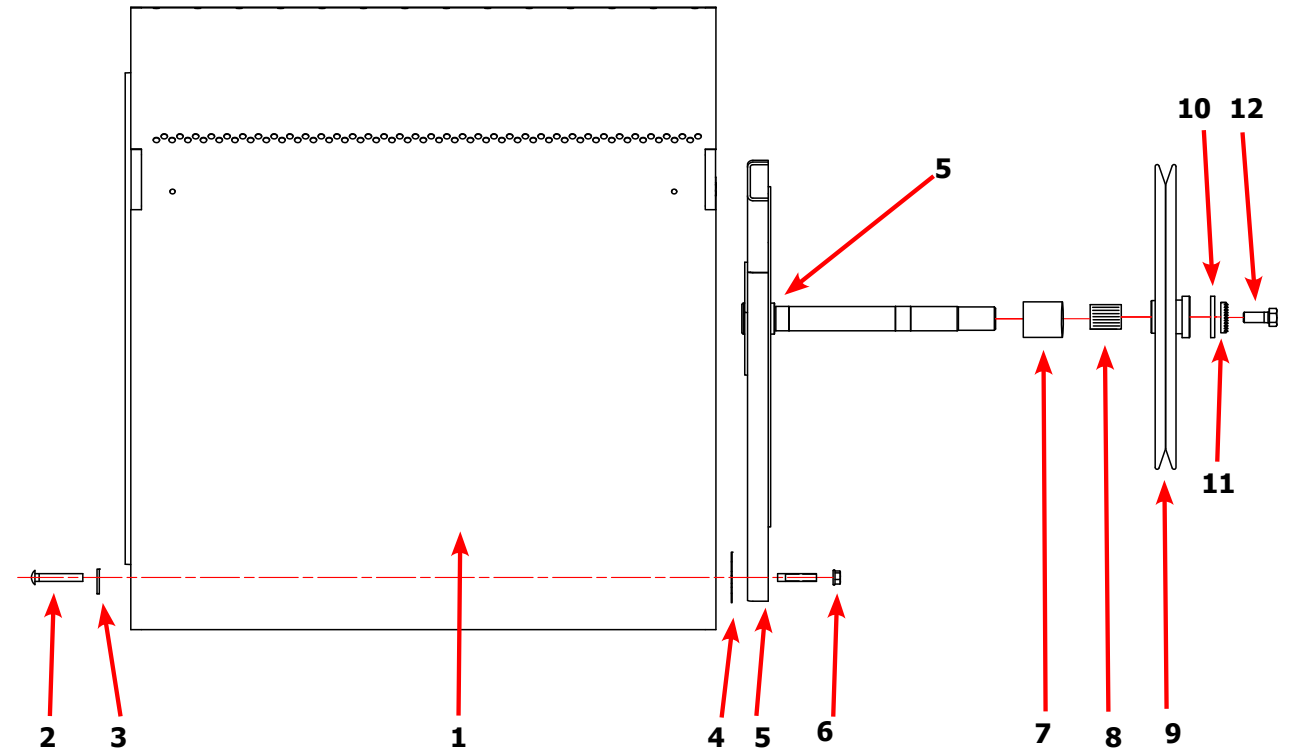

10, 11, 12

Burner Housing Group

Key	Part Number	Description	Quantity
1a	9452-730-001	Service Burner Plate Front.....	2
1	9452-729-001	Service Plate baffle Recirculation Chamber Clean Out.....	2
2	9545-008-001	Screw	16
18	9003-220-001	Angle, Burner Support	2
17	9048-020-001	Burner, Main	4
4	9545-008-001	Screw 10B x1/4"	8
5	9875-002-003	Electrode Assy, Ignition	2
19	9545-045-001	Screw, Electrode Mtg 8B x 1/4".....	4
7	9379-186-001	Valve, Gas Shut Off (Optional).....	1
8	9857-134-001	Control Assy, Gas	2
9	9381-009-006	Manifold, Assy	2
10	9029-047-001	Bracket, Manifold	2
22	8615-104-038	Pipe Plug in end of Burner Manifold	2
11	9452-749-001	Plate Assy, Hi-Limit Stat Ignitor	2
12	9576-203-002	Thermostat, Hi-Limit	2
13	9074-315-001	Cover, Hi-Limit Stat Ignitor	2
15	9825-058-001	Cover, Safety Stat	2
16	9857-116-003	Control, Ignition Fenwall (3 trybox).....	2
*	9803-199-001	Housing Assembly, Burner	2
*	9545-008-006	Screws	8
*	9545-008-006	Screw	4
*	9545-008-006	Screw 10AB x 3/8"	4
*	9454-796-001	Panel, Back Burner Housing.....	2
*	9425-069-023	Orifice, Burner-Natural #125	4
*	9425-069-024	Orifice, Burner-LP #49	4
*	9039-915-001	Bracket, Gas Control	2
*	9545-008-006	Screw	4
*	9538-142-001	Spacer, Hi-Limit	4
*	9545-045-007	Screw 8B x 3/4".....	4
*	9545-008-006	Screw	6
*	9576-207-008	Thermostat, Safety Shutoff	2
*	9545-008-006	Screw	4
*	9545-008-006	Screw	4
*	9550-173-001	Shield, Burner Inlet	1
*	9732-102-011	Kit, LP Conversion DDAD Kit	2
*	8515-104-037 ^	Elbow 90 Black.....	4
*	8665-073-040	Nipple 1/2" x 2 Black	2
*	8665-073-044 ^	Nipple 1/2" x 4 1/2" Black	2
*	8615-104-035 ^	Union 1/2" Black.....	2
*	9458-020-002 ^	Pipe Black	1
*	8615-104-034 ^	Tee 1/2" x 1/2" x 1/2" Long Black	2
*	9838-018-001 ^	Welded One Piece Gas Pipe Assembly (Used After 9/07)	
*	9381-012-001 ^	Manifold Assembly 2 Port One Piece (Used After 9/07)	

^ Models built before 9/07

Burner Housing Group Photos

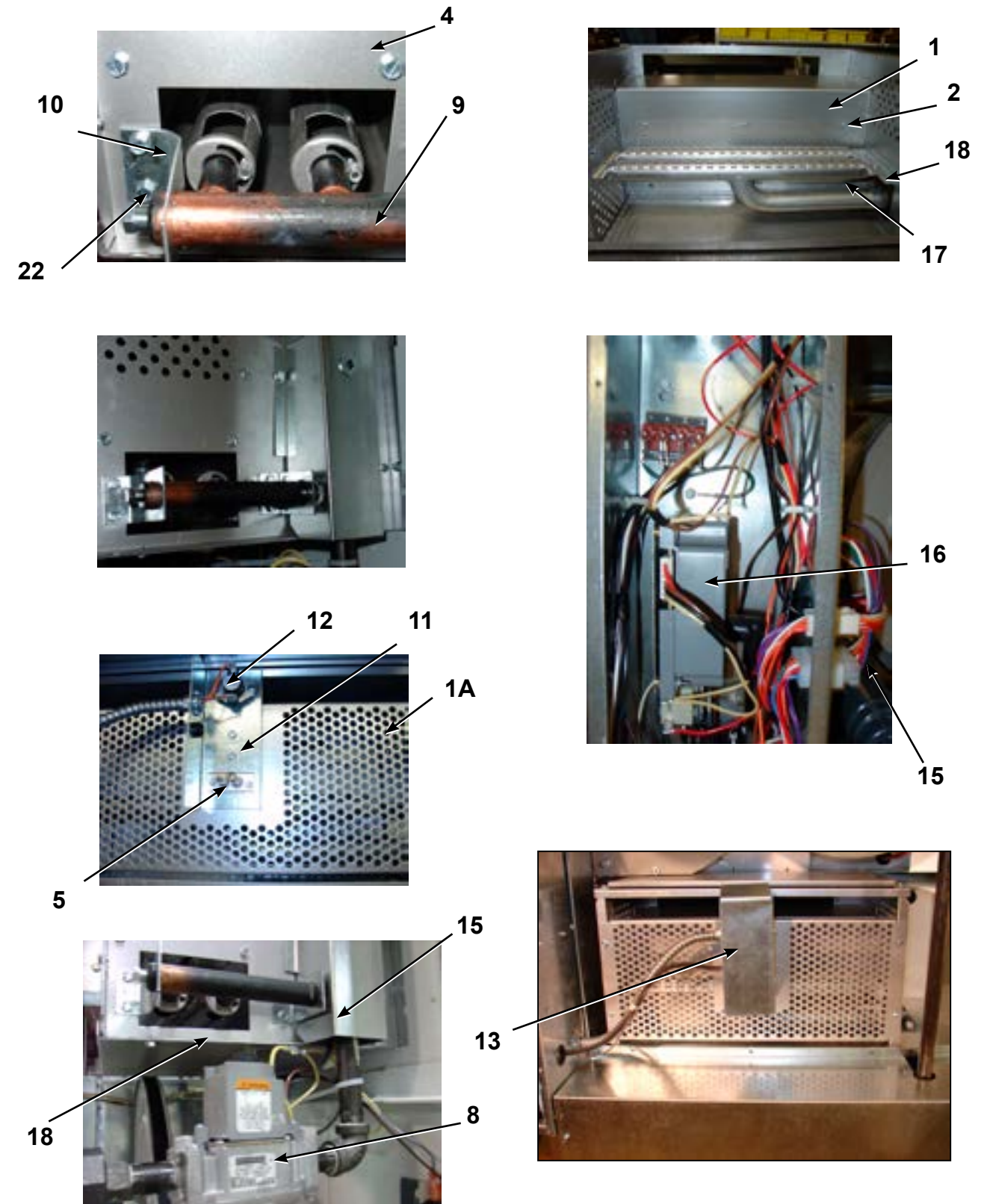

Rear View

Key	Part Number	Description	Quantity
*	9627-861-001	Wire Harness Overtemperature Switch	2
*	9801-095-001	Switch Assy, Air Flow	2
1	9539-461-009	Switch, Air Flow	2
2	9029-174-001	Bracket, Switch- Air Flow	2
3	9008-007-001	Actuator, Switch	2
4	9451-169-002	Pin, Cotter	2
5	9545-020-001	Screw 4-40 x 5/8"	4
*	8640-401-001	Nut, Special Twin #4-40	2
*	9550-169-003	Shield, Switch	2
*	9545-008-001	Screw 10 Bx 1/4"	6
7	9376-309-003	Motor, Drive	2
*	9732-205-002	DDAD Motor Kit	2
*	5191-107-001	Motor Start Capacitor	1
8	9452-740-001	Plate, Motor Mtg	2
*	9545-029-008	Bolt 3/8" - 16 x 3/4"	8
*	8641-582-003	Lockwash Spring 3/8	8
9	9545-018-019	Screw, Motor Plate to Back Assy. 1/4-20x 2 1/2	8
9	86411-582-007	Lockwasher 1/4	8
9	9538-,163-006	Spacer	8
9	8641-581-017	Flat Washer 1/4 x 7/8	24
9	9209-086-002	Rubber Grommet	8
*	9538-166-006	Grommet Spacers	8
27	9453-157-001	Pulley, Motor	2
*	9545-028-013	Screw, Set	4
10	9962-017-002	Back Assy, Blower Hsg	2
26	9278-039-001	Impeller, W/Set Screws	2
11	9991-053-001	Support Assy, Intermed. Pulley	2
12	9545-029-010	Bolt, Rd Hd 3/8-16 x 1 1/4	6
13	9545-029-003	Bolt, 3/8-16 x 1 1/2	2
12	8640-415-004	Nut Flange Wizioc 3/8" - 16	6
12	8641-581-035	Washer, Flat	6
14	9861-022-001	Arm Assy-Tension, Complete	2
*	8641-581-035	Washer, Flat	2
15	9487-200-003	Ring-Retaining	6
16	9908-039-004	Pulley Assy, Intermediate with bronze flange bearing	2
*	9036-145-002	Bearing - Bronze Flange	4
17	9908-040-001	Pulley Driven (Before Serial # 226213)	2
17	9908-049-002	Pulley Driven (After Serial # 226213) see Tumbler group	2
*	9538-164-001	Spacer, Shaft	2
*	9306-006-000	Key, Tumbler Shaft Woodruff	2
18	8640-222-000	Nut, Hex 1"-14	2
18	86AI-582-015	Washer, Lock	2
19	9040-077-001	Belt, Drive- Motor	2
20	9040-073-009	Belt, Drive- Tumbler	2
21	9534-319-002	Spring, Tension	2
22	9099-012-002	Chain, Tension	2
23	9248-,022-002	Hook, Tension	2
*	9125-005-001	Damper Inside Duct Exhaust	2
24	9451-146-001	Pin, Damper Hinge	2
*	8520-141-000	Nut, Spring	4
*	9545-008-026	Screw #10B x 1/2	6
25	9825-059-001	Cover Duct Upper	1
*	9074-314-001	Cover Duct Lower	1
*	9545-008-024	Screw 10ABx 3/8"	80
25	9973-030-001	Heat Recirculation Assembly Duct	2
27	9453-157-001	Motor Pulley - Driver	1
*	9029-173-001	Bracket for Wire Harness Under Burner Housing	2

Rear View Photos

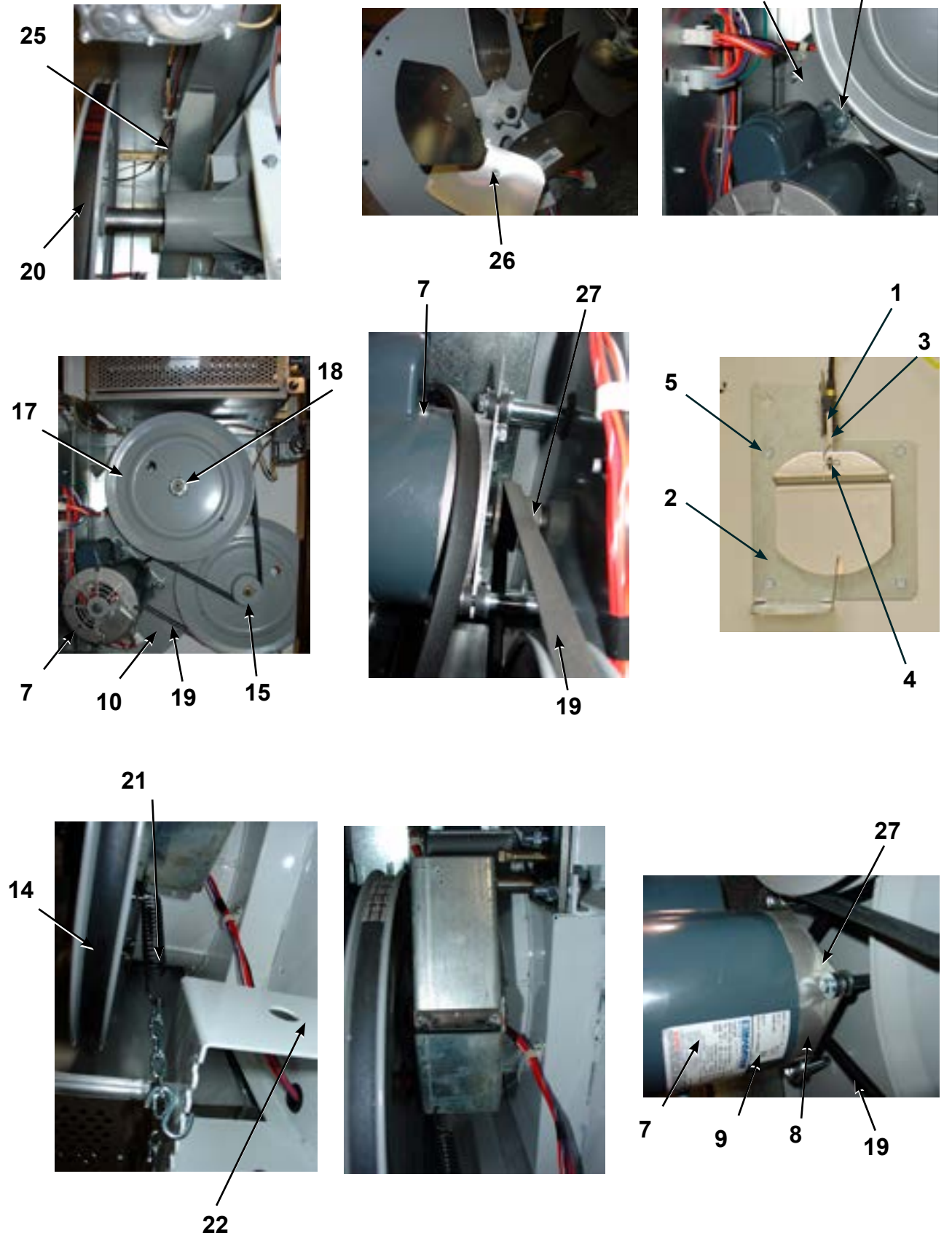

Rear Panel & Cover Group

Key	Part Number	Description	Quantity
1	9208-075-001	Back Drive Guard Panel before serial#200860	2
1	9208-083-001	Back Drive Guard Panel after serial#200860	2
*	9545-008-024	Back Guard Screws.....	*
2	9208-076-001	Back Side Guard Panel Ass'y	2
3	9074-261-001	Cabinet (TOP COVER)	1
*	8544-006-001	Legs Leveling	4
4	9074-317-001	Electric Box Cover Screws Only	6
5	9545-008-024	Screws 10 AB x 3/8.....	4
6	9577-062-001	Top Duct w/ Oval.....	1
6	9109-113-001	Top Duct w/ Round.....	1
4	9108-117-001	Electric Box Cover w/ Hinge.....	1
*	9074-319-001	Lower Duct Cover / Board.....	1
*	9973-034-001	8" Slide Open Clean Out Duct (Optional).....	1



Screws



Door Switch Group

Part Number	Description	Quantity
9539-487-001	Door Switches	2



**Hinge Plate Cover
(after Serial # 220625)**

- 1 9074-341-002 Cover-Hinge, Black.....2
 Note: Before Serial # 220625 Holes can be drilled in hinge plate to install (#18 Drill bit).
 2 9545-008-010 Screw-TRHDCR, 10B x 3/8, Black.....4

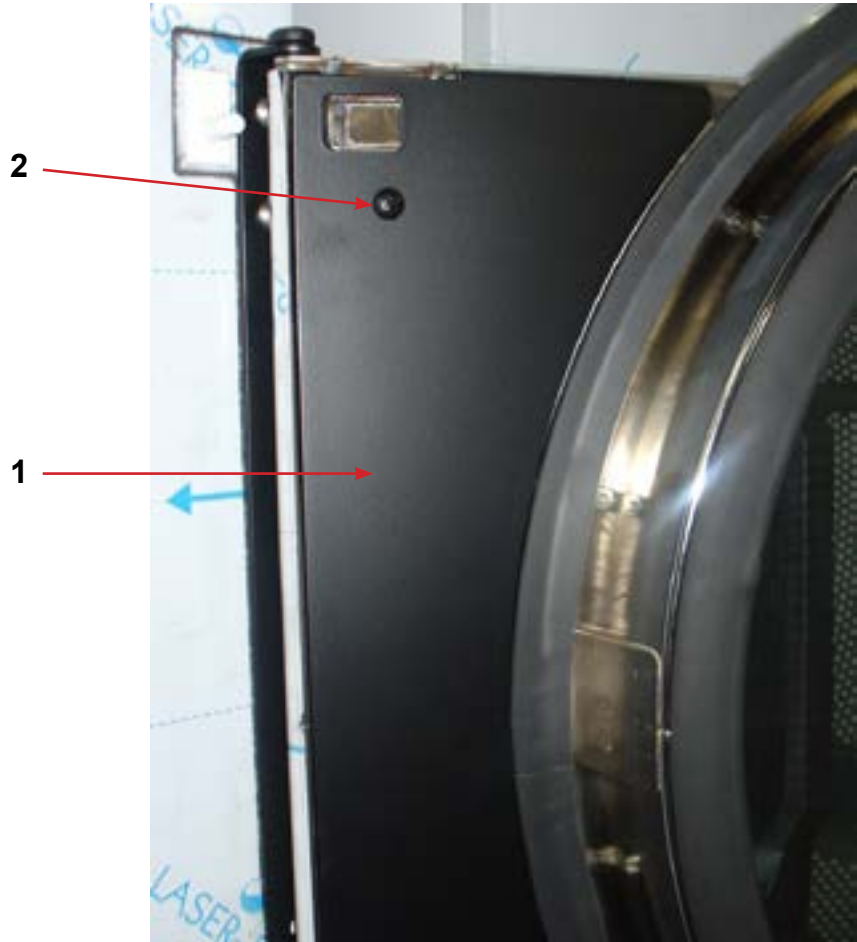

Notes

Lined area for handwritten notes, consisting of multiple horizontal lines for text entry.

Control Assembly Group

Key	Part Number	Description	Quantity
1	9074-317-001	Control Box Cover	1
2	8220-001-478	Wire Assembly Green 7"	1
3	9897-026-002	Terminal Block Main Power Middle	1
4	9897-026-001	Terminal Block	2
5	8711-011-001	Transformer Ignition.....	2
6	9982-348-001	Plate Assembly MTG Ignition Control.....	2
7	9857-116-003	Ignition Control	2
8	9631-403-007	Wire Assembly High Voltage Upper	1
9	9627-860-001	Wire Harness Ignition Control Upper.....	1
10	9627-860-002	Wire Harness Ignition Control Lower.....	1
11	9053-067-002	Bushing Wire 7/8"	4
12	8653-068-003	Connector Conduit 3/8" STR	1
13	9200-001-002	Fuseholder Assembly	3
14	8636-018-001	Fuse 1.5 Amp.....	3
15	5192-298-001	Relay Power (before Serial # 217612)	2
15	5192-299-001	Relay Power (after Serial # 217612)	2
16	9897-036-002	Terminal Block Assembly Main Power Inlet.....	1
17	8220-062-036	Wire Assembly Red/Black 14"	1
18	8220-062-037	Wire Assembly Red/White 14".....	1
19	8220-062-038	Wire Assembly White 14"	2
20	9627-859-001	Wire Harness - Power Main.....	1
21	9627-864-001	Wire Harness Motor Extension.....	2
22	9558-031-001	Strip Terminal Marker (Behind Input Power) to above #3.....	1
*	9857-169-001	Control Assmly Complete (all below included)	1
*	8639-621-007	Screw # 10-32 x 12 Green.....	1
*	8641-582-006	Lockwasher Ext Tooth #10	1
*	9545-045-012	Screw #8 ABx1 2 for terminal block.....	6
*	9545-008-024	Screws 10AB x 3/8"	4
*	9545-008-001	Screws 10B x 1/4" MTG Above Plate	4
*	8640-411-003	#6-32 Screws	4
*	9631-403-006	Wire Assembly High Voltage Lower	1
*	9545-045-012	Screws Power #8 AB x 1/2".....	4
*	9545-045-012	Screw #8 AB x 1/2".....	1
*	9527-007-001	Stand Off - Wire Saddle / Arrowhead	5
*	9545-031-005	Screw 6 B x 3/8"	4
*	9627-863-001	Wire Harness Main Extension Access Under Burner Housing	1

Control Assembly Group

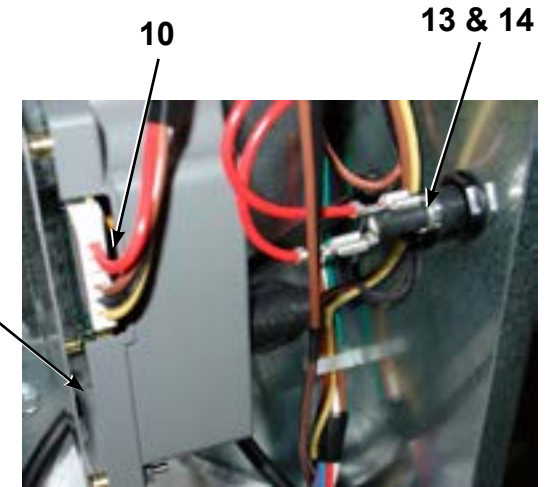
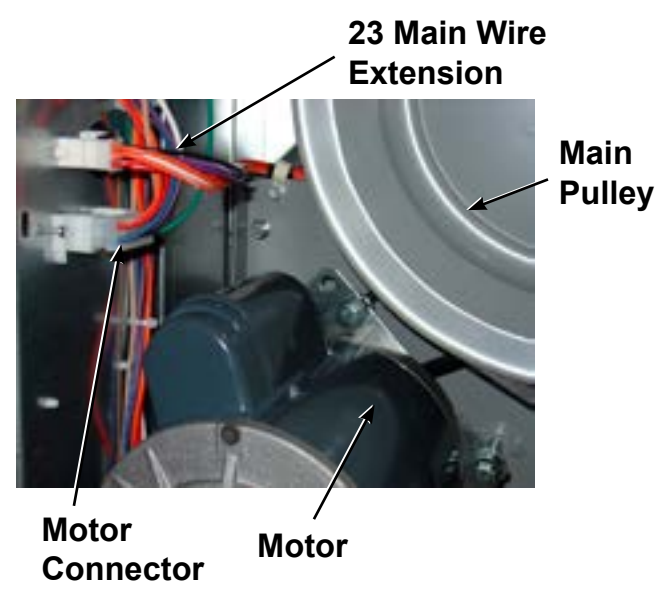
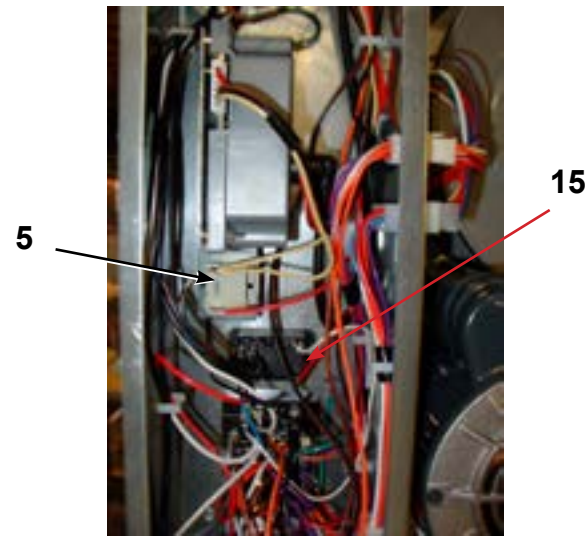
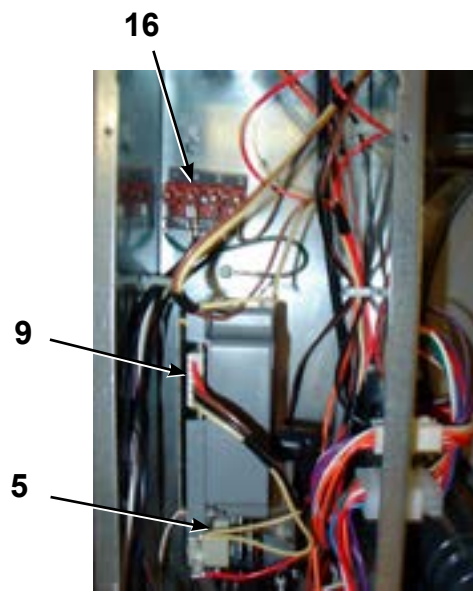
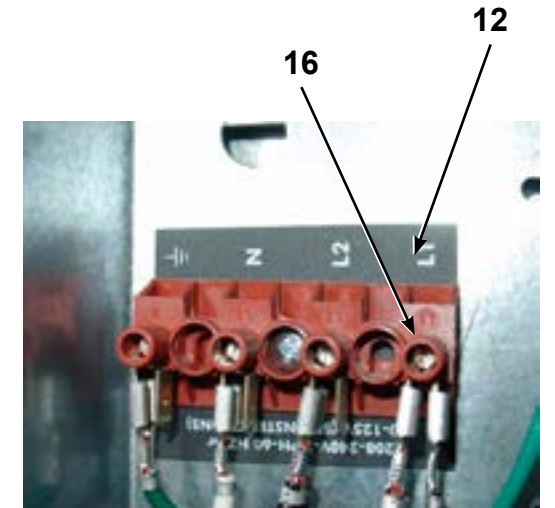
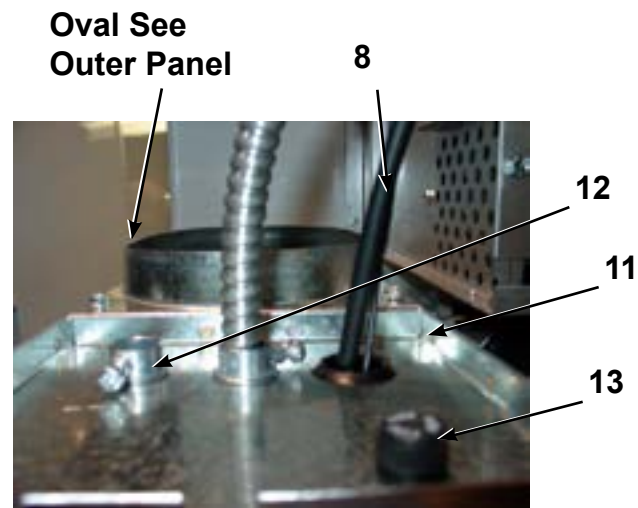
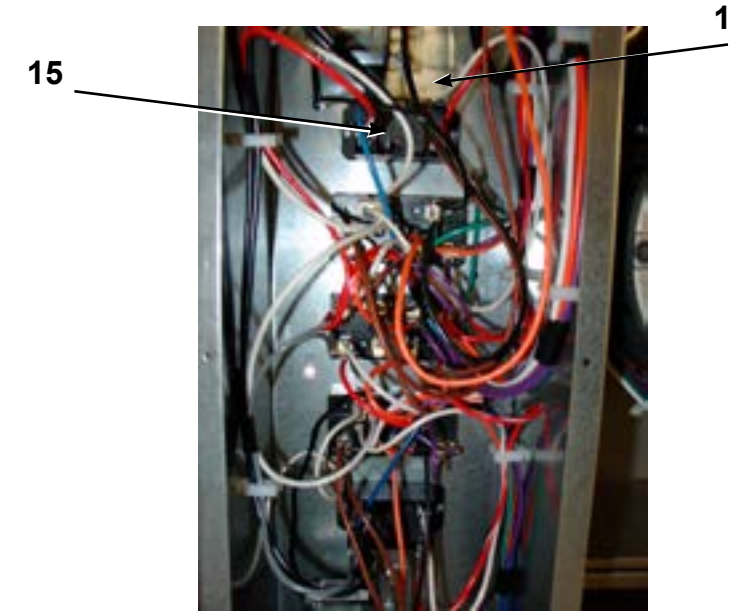

Control Assembly Group Change w/control Protection Fus

13	9200-001-002	Fuseholder Assembly	3
14	8636-018-001	Fuse 1.5 Amp	3

Control Protection Fuse

24VAC Ignition Upper Pocket Protection Fuse

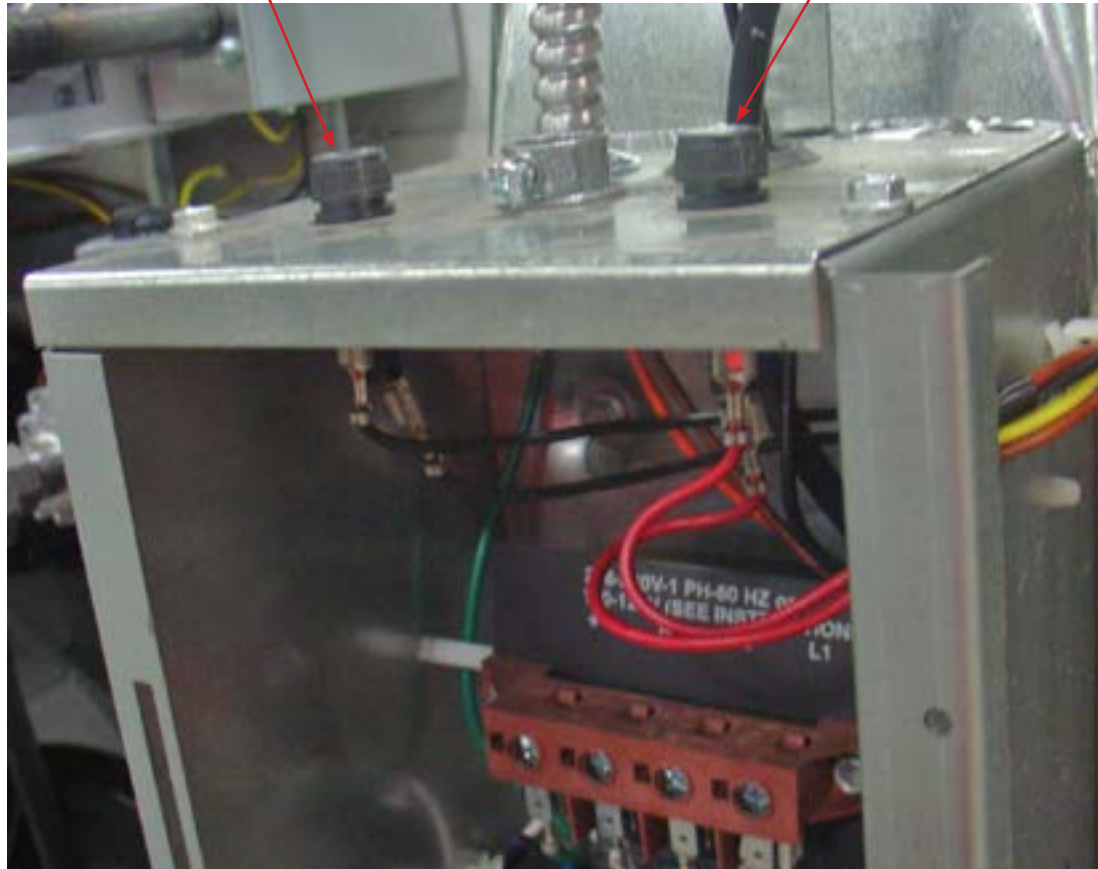

Not Shown:
24VAC Ignition Lower
Pocket Protection
Fuse

Notes

Coin Handling Group

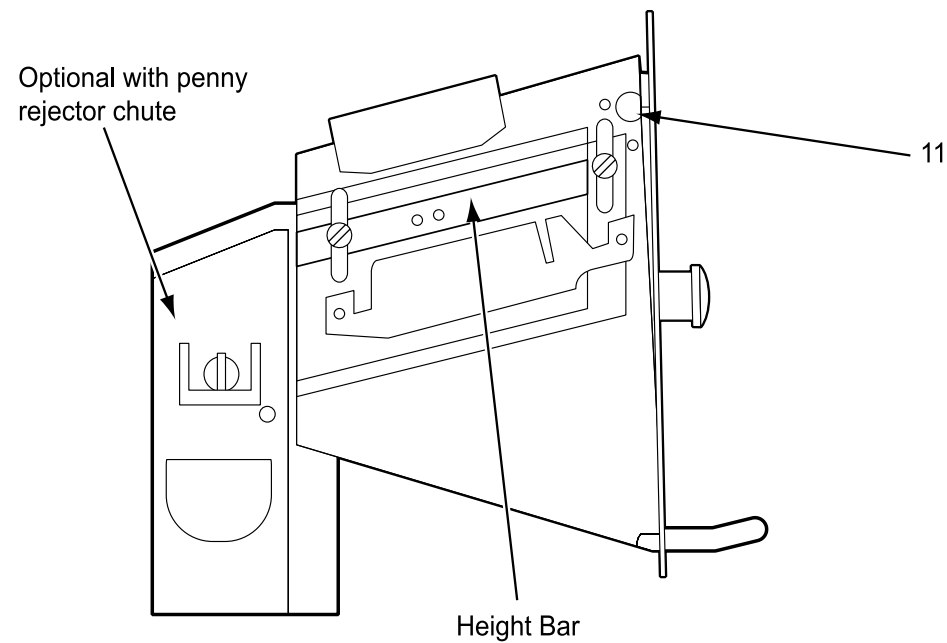
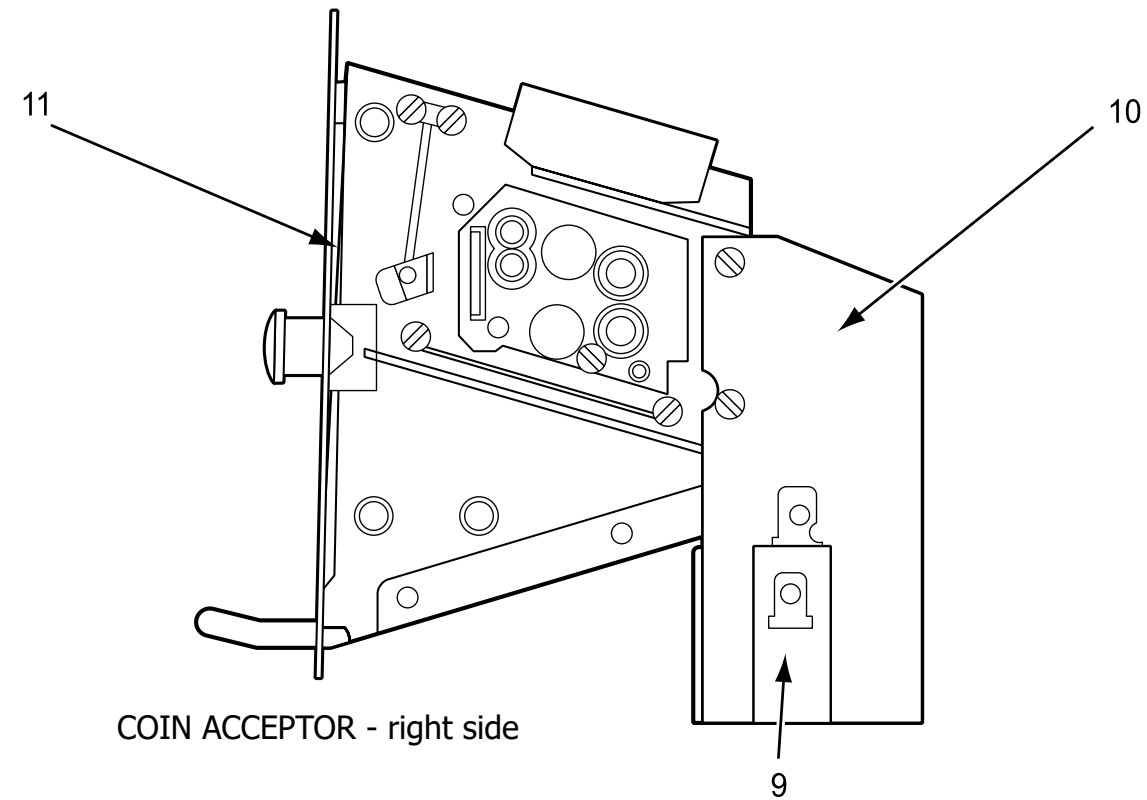

Coin Handling Group

Key	Part Number	Description	Quantity
2	9732-122-001	Kit, Coin Box and Hardware (includes 1-6).....	1
*	9942-034-002	Vault, Assembly Gray (SS front panel)	1
*	9942-034-004	Vault, Assembly Almond	1
*	9942-034-003	Vault, Assembly White	1
*	9942-038-005	Vault, Assembly Black Large Coin Box (Serial # 222035)...	1
*	9982-338-001	Mounting Plate, Large Vault.....	1
*	9545-008-024	Screws, Large Vault Mounting.....	2
1	9807-077-007	Box Assembly, Coin	1
*	9982-338-001	Vault Plate Assembly Coin Vault Mounting	4
*	8640-413-004	Nut, Vault Mounting.....	4

NOTE: COIN BOX AND HARDWARE KIT AND COIN BOX LOCK NOT INCLUDED WITH MACHINE.

3	9349-033-001	Latch, Coin Box	1
4	8641-569-002	Washer, Wave	1
5	8641-583-001	Washer, Keeper	1
6	8641-581-008	Washer, Spacer- Thick	2
6	8641-581-010	Washer, Spacer- Thin	4
7	8650-012-002	Lock, Coin Box (w/key not included with 9732-122-001).....	1
8	9021-001-010	Acceptor, Coin.....	1
*	9545-053-002	Screw, Acceptor Mtg	4
9	9732-126-001	Switch, Coin	1
10	9119-025-002	Acceptor Chute Ass'y w/o penny ejector	1
*	9119-025-001	OPTIONAL Acceptor Chute W/ penny rejector	*

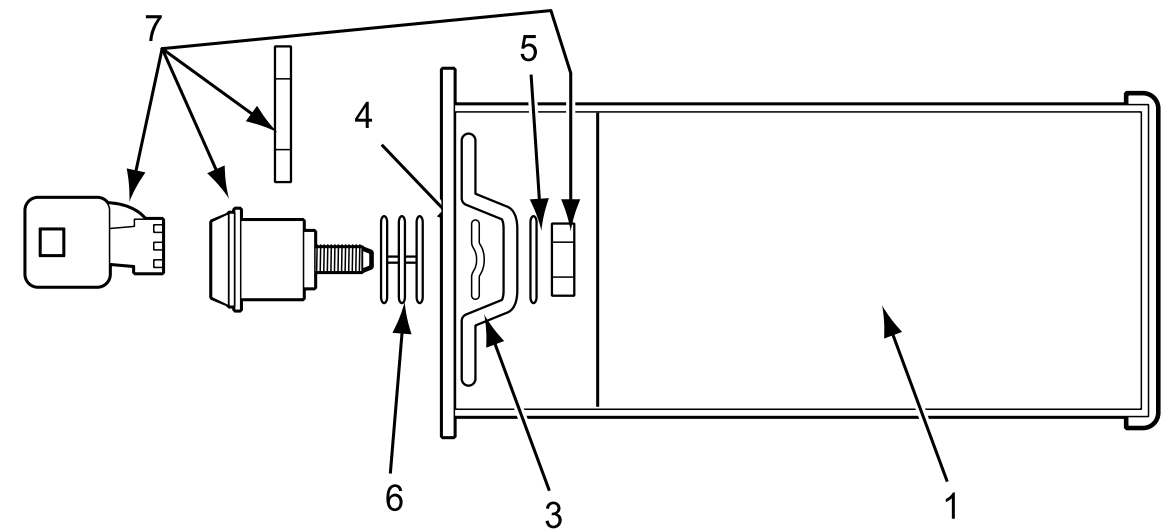

Wiring Diagram for DDAD Dryer

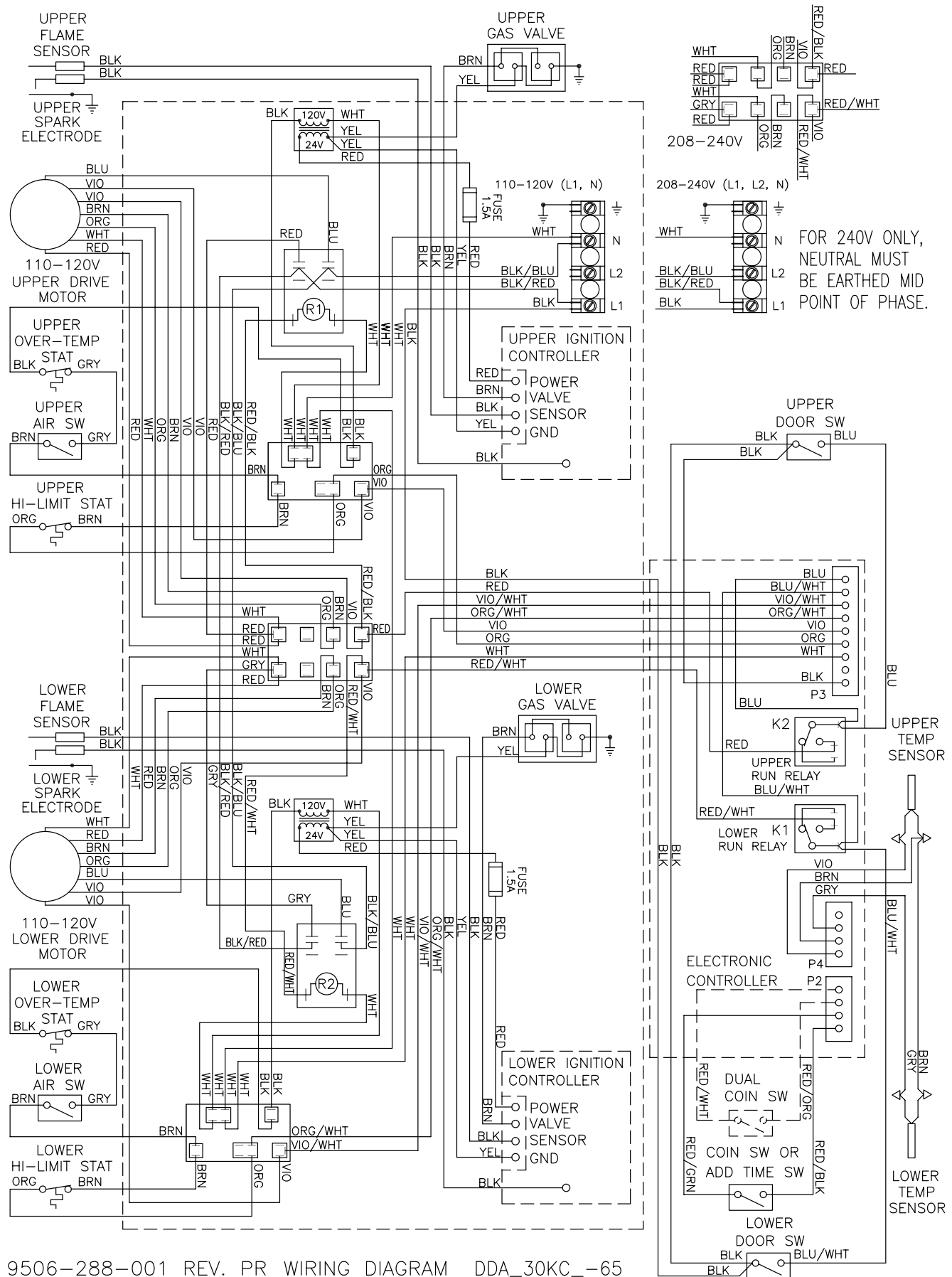

9506-288-001 REV. PR WIRING DIAGRAM DDA_30KC_-65

IMPORTANT: RETAIN THIS ELECTRICAL DIAGRAM FOR SERVICE

Wiring Schematic for DDAD Dryer

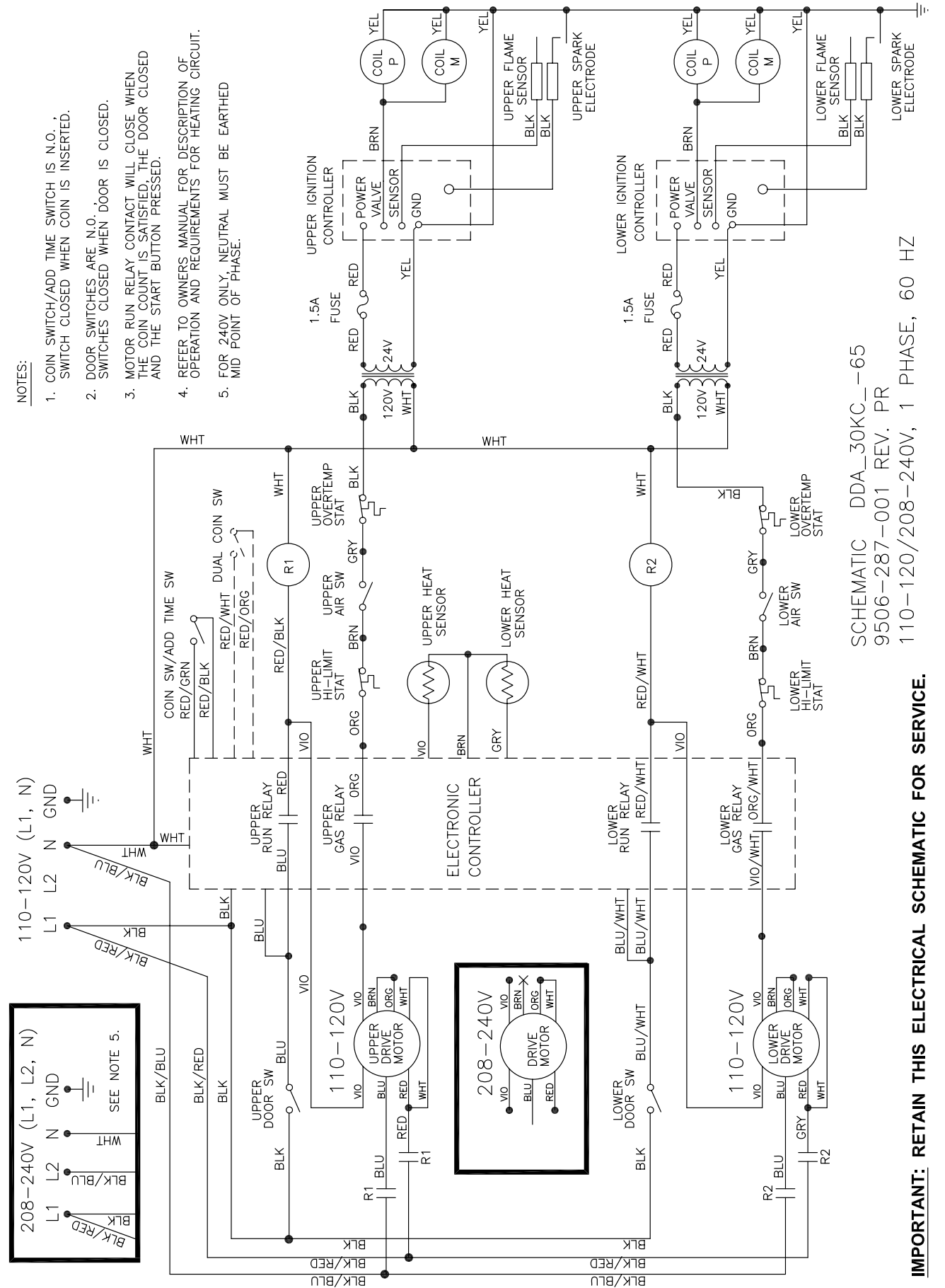

- NOTES:**
1. COIN SWITCH/ADD TIME SWITCH IS N.O. SWITCH CLOSED WHEN COIN IS INSERTED.
 2. DOOR SWITCHES ARE N.O. SWITCHES CLOSED WHEN DOOR IS CLOSED.
 3. MOTOR RUN RELAY CONTACT WILL CLOSE WHEN THE COIN COUNT IS SATISFIED, THE DOOR CLOSED AND THE START BUTTON PRESSED.
 4. REFER TO OWNERS MANUAL FOR DESCRIPTION OF OPERATION AND REQUIREMENTS FOR HEATING CIRCUIT.
 5. FOR 240V ONLY, NEUTRAL MUST BE EARTHED MID POINT OF PHASE.

SCHEMATIC DDA_30KC_-65
9506-287-001 REV. PR
110-120/208-240V, 1 PHASE, 60 HZ

IMPORTANT: RETAIN THIS ELECTRICAL SCHEMATIC FOR SERVICE.

Wiring Diagram for DDAD Dryer w/control Protection Fuse

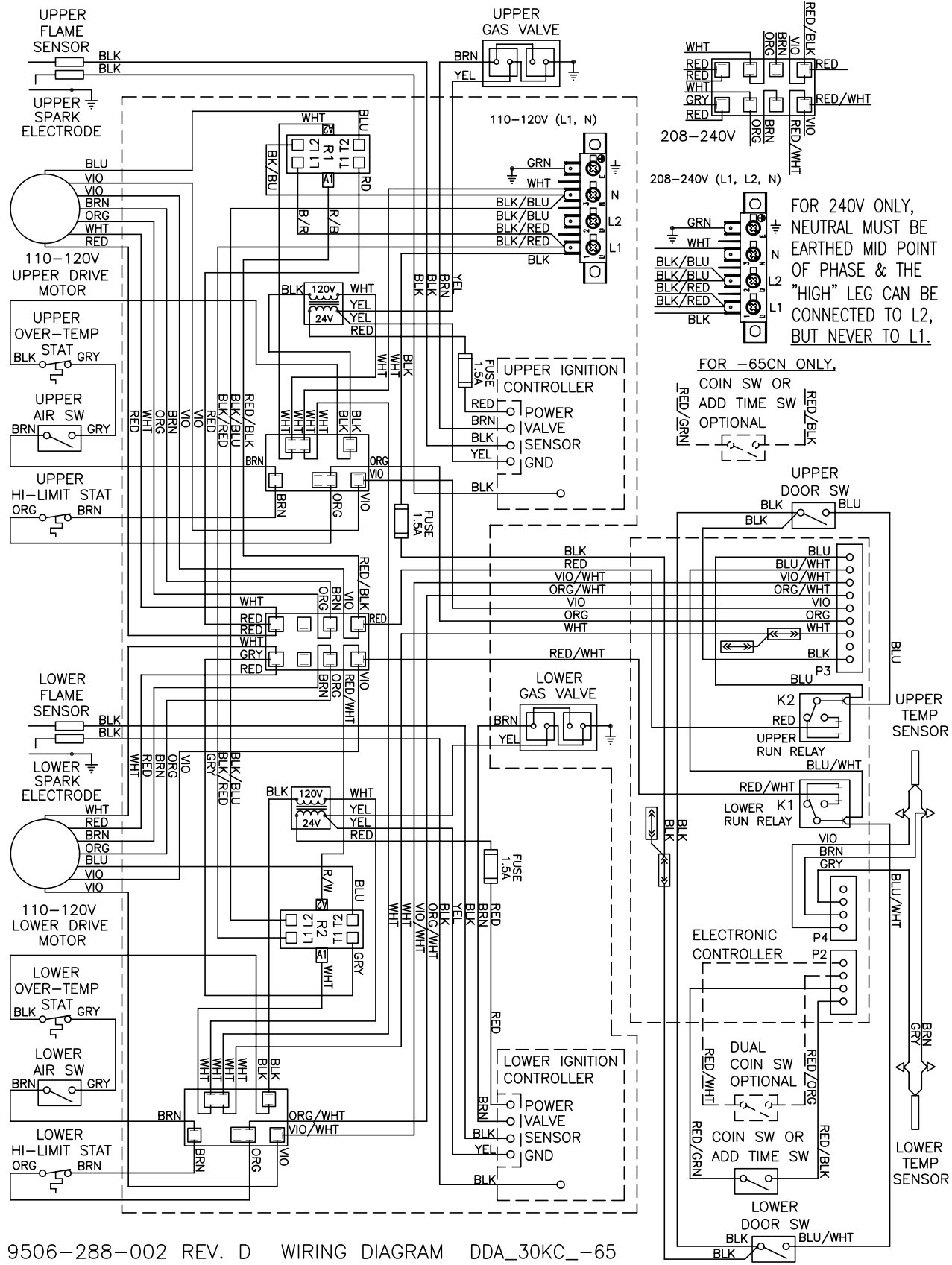

9506-288-002 REV. D WIRING DIAGRAM DDA_30KC_-65

IMPORTANT: RETAIN THIS ELECTRICAL DIAGRAM FOR SERVICE.

Wiring Schematic for DDAD Dryer w/control Protection Fuse

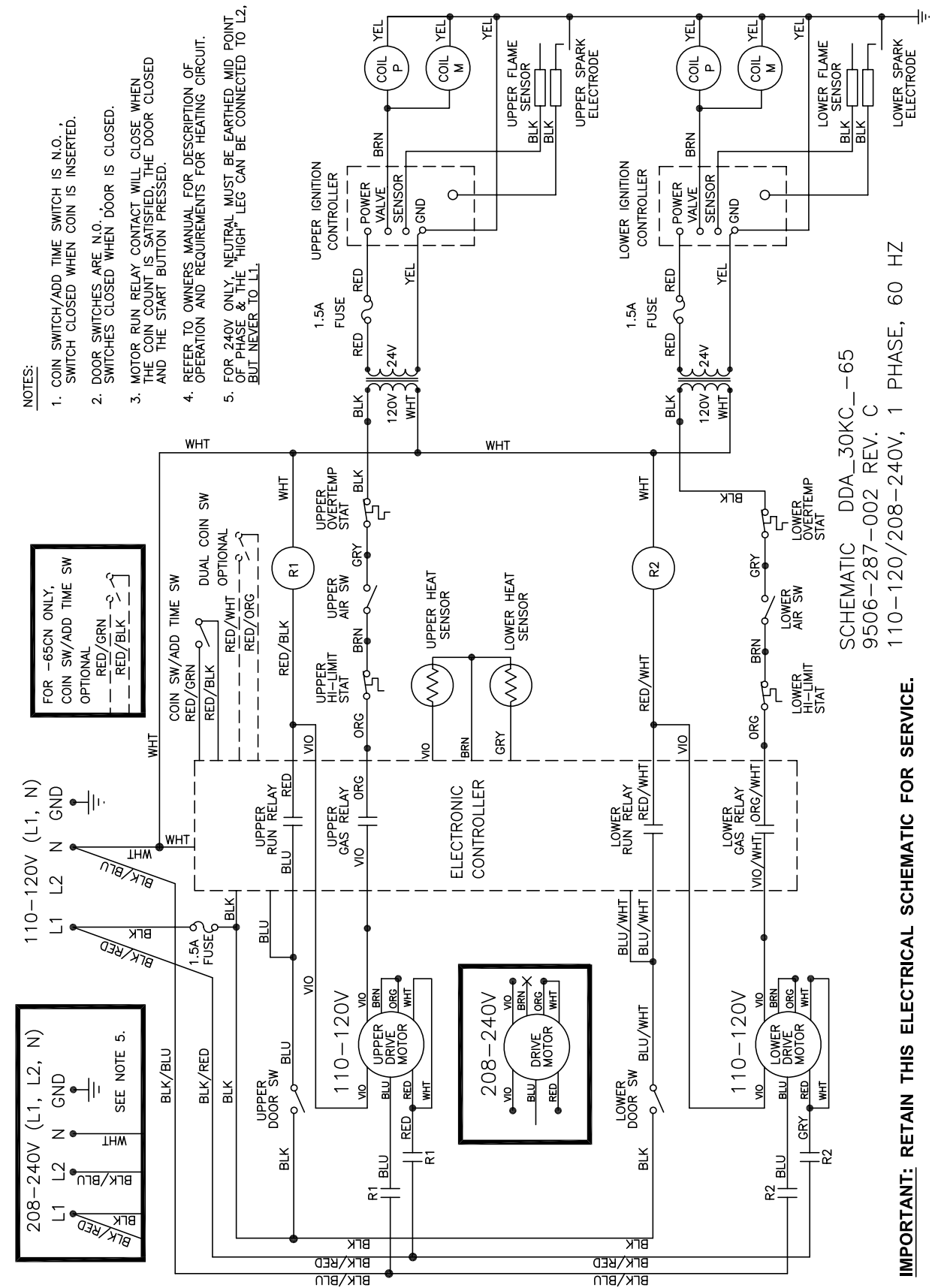

- NOTES:**
1. COIN SWITCH/ADD TIME SWITCH IS N.O. SWITCH CLOSED WHEN COIN IS INSERTED.
 2. DOOR SWITCHES ARE N.O. SWITCHES CLOSED WHEN DOOR IS CLOSED.
 3. MOTOR RUN RELAY CONTACT WILL CLOSE WHEN THE COIN COUNT IS SATISFIED, THE DOOR CLOSED AND THE START BUTTON PRESSED.
 4. REFER TO OWNERS MANUAL FOR DESCRIPTION OF OPERATION AND REQUIREMENTS FOR HEATING CIRCUIT.
 5. FOR 240V ONLY, NEUTRAL MUST BE EARTHED MID POINT OF PHASE & THE "HIGH" LEG CAN BE CONNECTED TO L2, BUT NEVER TO L1.

SCHEMATIC DDA_30KC_-65
9506-287-002 REV. C
110-120V/208-240V, 1 PHASE, 60 HZ

IMPORTANT: RETAIN THIS ELECTRICAL SCHEMATIC FOR SERVICE.

Preventative Maintenance

Daily

- Step 1:** Clean the lint screen free of lint and other debris. Use a soft brush and Hot water if necessary.
- Step 2:** Check the lint screen for tears. Replace if necessary.
- Step 3:** Clean lint from the lint screen compartment.
- Step 4:** Inspect felt seal on lint screen assembly, replace if needed.

Monthly

- Step 1:** Remove lint accumulation from the end bells of the motor.
- Step 2:** Remove lint accumulation from front control area.
- Step 3:** Remove lint and dirt accumulation from the top of the dryer and all areas above, below, and around the burners and burner housing. Failure to keep this portion of the dryer clean can lead to a build-up of lint creating a fire hazard.
- Step 4:** Remove and clean coin acceptors. (Vended Models Only)

Quarterly

- Step 1:** Check the belts for looseness, wear, or fraying.
- Step 2:** Inspect the gasket of the door glass for excessive wear.
- Step 3:** Check tightness of all fasteners holding parts to support channel.
- Step 4:** Check tightness of all set screws.
- Step 5:** Remove the air flow switch assembly and check the tumbler thru-bolts for tightness.
- Step 6:** Apply a few drops of oil to pivot pins and the tension arms where in contact with each other.

Semi-Annually

- Step 1:** Remove and clean the main burners.
- Step 2:** Remove all orifices and examine for dirt and hole obstruction.
- Step 3:** Remove all lint accumulation. Remove the front panel and the lint screen housing and remove lint accumulation.

Annually

- Step 1:** Check the intermediate pulley bearings for wear.
- Step 2:** Check and remove any lint accumulation from the exhaust system including recirculation chambers if applicable.
- Step 3:** Grease the bearings and the shaft of the intermediate pulley. Use an Alemite grease gun and Molykote BR2-S grease. (Where applicable)

Section 8: Voltage Conversion

Instructions - Convert a Dual Voltage Stack Dryer from 120V to 208-240V with Neutral Wire Only

1. Remove incoming power from the dryer. Use a known working voltmeter to check power.
2. Remove the cover of the control box assembly from the dryer using a 5/16" wrench.
3. Move the black/blue wire from the N position of the main power terminal block to the L2 position of the main power terminal block in the control box assembly. See Figure 1 below.
4. Move the white wire of the upper motor harness to an upper inner left terminal in the middle terminal block in the control box assembly. See Figure 1 below.
5. Move the orange wire of the upper motor harness to an upper inner left terminal in the middle terminal block control box assembly. See Figure 1 below.
6. Move the white wire of the lower motor harness to a lower inner left terminal in the middle terminal block in the control box assembly. See Figure 1 below.
7. Move the orange wire of the lower motor harness to a lower inner left terminal in the middle terminal block control box assembly. See Figure 1 below.
8. Reconnect power to the dryer and test to ensure proper operation; one line voltage to L1, one line voltage to L2, the neutral to N, and the earth ground to E.
9. Reinstall the cover of the control box assembly from the dryer using a 5/16" wrench.

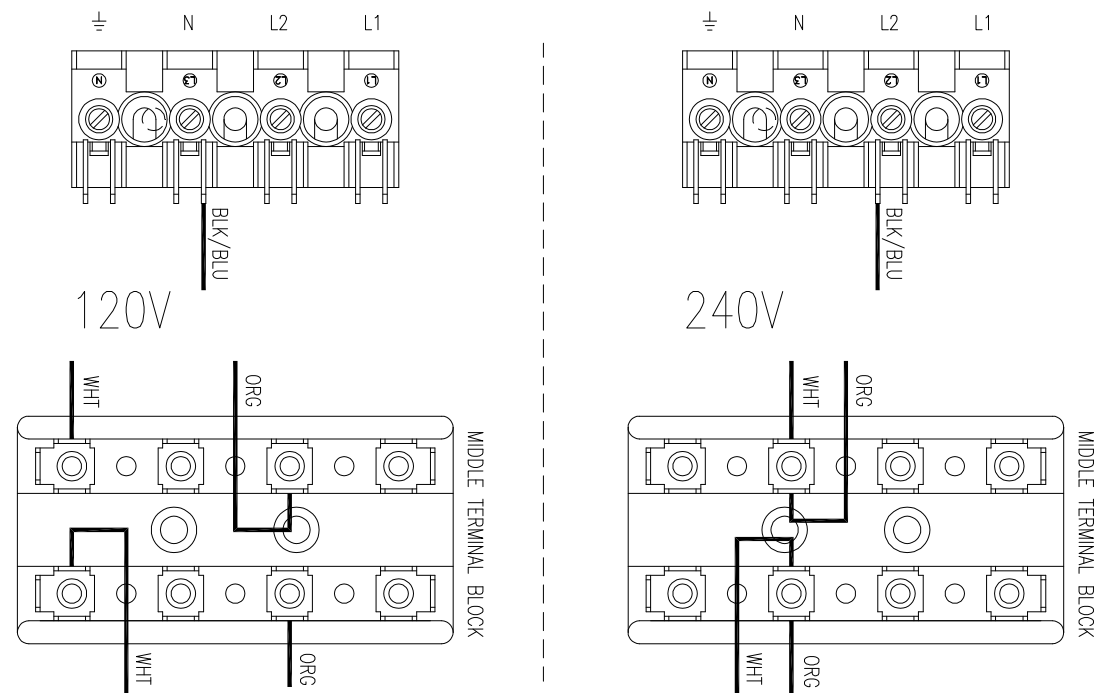
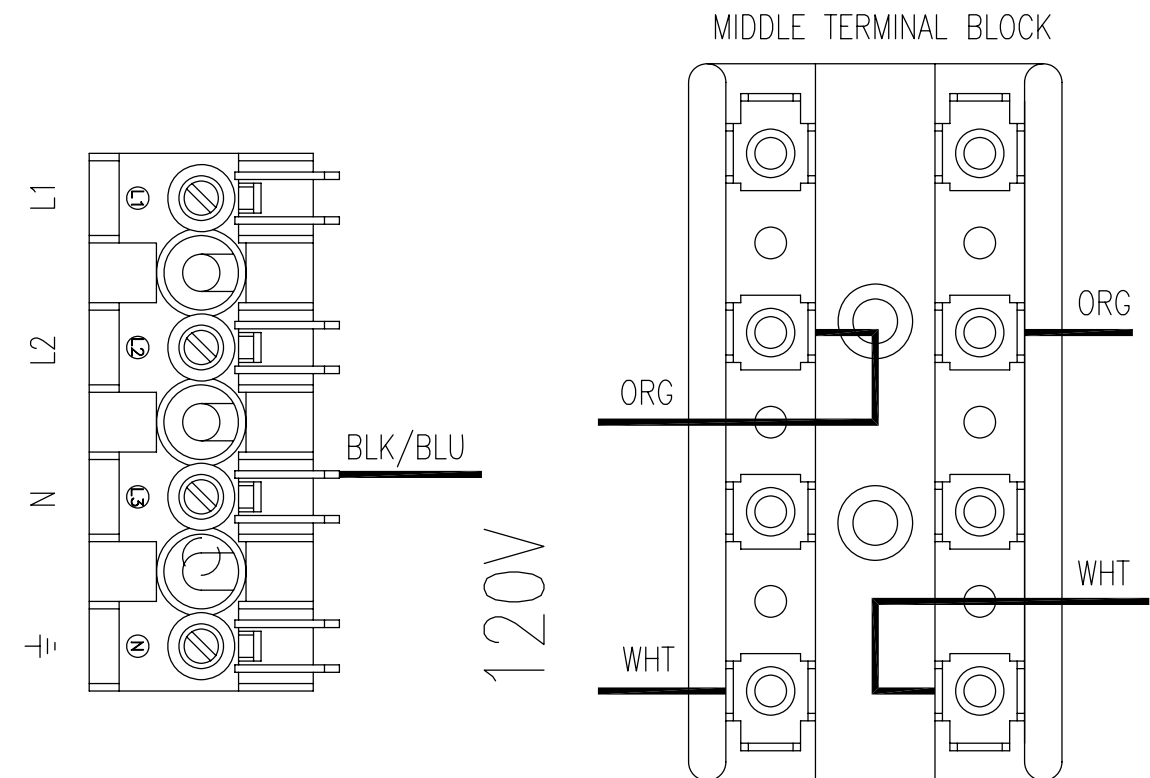
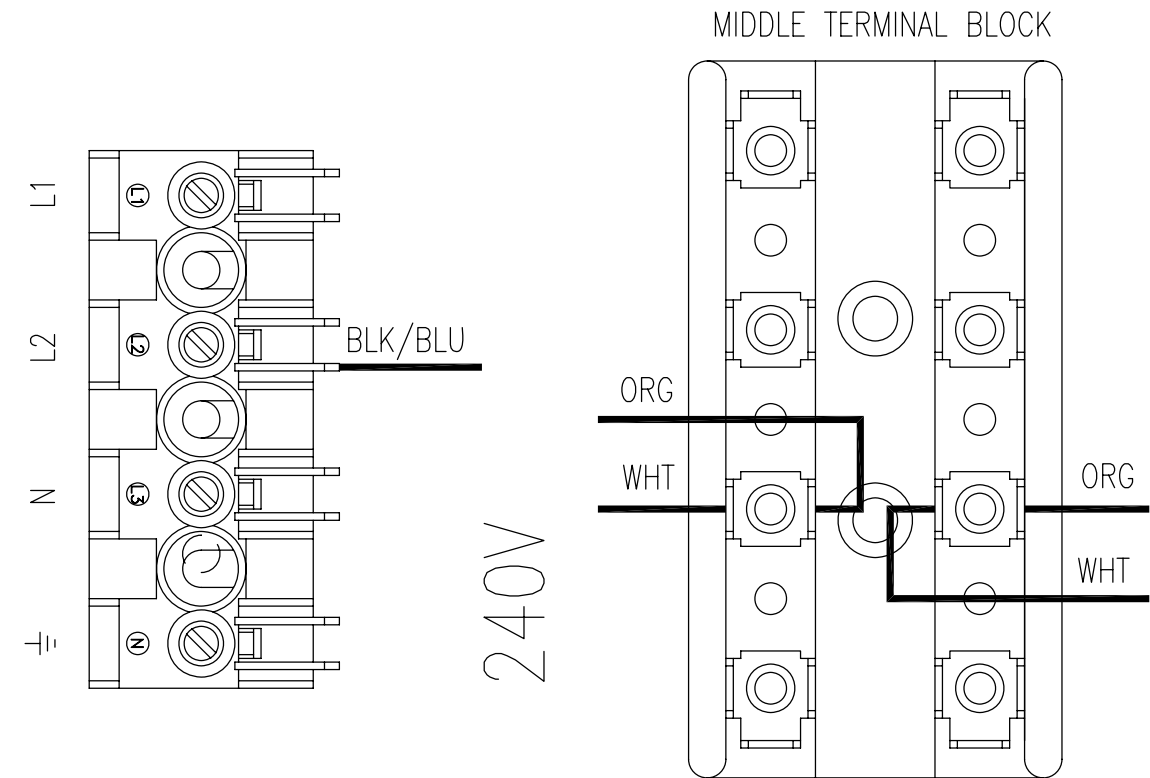

Figure 1 Dual Voltage Stack Dryer Voltage Conversion



**DUAL VOLTAGE STACK DRYER
VOLTAGE CONVERSION**

50HZ Wiring Schematic Dryer Idle - No Coins Added

Top Dryer Used For This Example

230 VAC 50 HZ is supplied to the Main Power Terminal Block and passes through a In-line Noise Filter and comes out on BLK/RED and BLK/BLU wire. 230 VAC now passes to a Multitap Control Step Down Transformer and also passes to the Motor Control Relay (R1&R2). When there is power to the dryer the Computer Board will be powered and the display lighted from the 24 VAC secondary side of Control Step Down Transformer. 24 VAC from here is also on one side of the door switch on a black wire. Closing the loading door allows 24 VAC to pass on to the Computer Board on two blue wires. One blue wire makes 24 VAC available to one side of the Motor Run Relay on Computer Board. The other blue wire provides a 24 VAC signal to the Computer Board telling it that the door is closed and door light on the computer board should be illuminated.

Coins Added - Motor Starting and Running

Top Dryer Used For This Example

As each coin is added the Coin Switch closes and completes a circuit to the Computer Board. The Computer Board counts these signals and registers them against time. The time will display once the Start Button for Upper or Lower is pushed. When the Start Button is pushed again the Computer Board Motor Run Relay closes on the computer. With this Relay closed, 24 VAC is supplied to the Motor Control Relay (R1) on the red wire and also a violet wire going down to motor. The motor LED on the computer board should be illuminated anytime the computer calls for the motor to operate. With (R1) engaged and 230 VAC at motor the Motor Start Switch in motor is drawn in to the start position. In this position the incoming power 230 VAC is supplied directly to the main run winding and through the Start Capacitor to the Auxiliary Winding (start winding). As the Motor comes up to speed, the centrifical switch inside motor opens the circuit to the Start Winding and closes the circuit to allow 24 VAC to pass to the Gas Relay on the Computer Board on the other violet wire. The heat circuit in the dryer can not operate if the motor is not running. The gas LED on the computer board will be illuminated when Computer Board calls for the heat after Motor Centrifical Switch has closed.

Heat Circuit

Top Dryer Used For This Example

With the Drive Motor running and 24 VAC provided to the Computer Board Gas Relay, it will close if Computer Board senses programmed temperature is needed. The violet wire changes to an orange wire out of the Computer Board Gas Relay. When this relay closes it provides 24 VAC to the High Limit Thermostat. The High Limit Thermostat is normally closed. (It will open, turning off the heat circuit, if the dryer can't move enough air from problems such as an exhaust restriction or other problems.) 24 VAC now goes through to the normally open Air Switch (Sail Switch) on the brown wire. This switch is closed only if the dryer is running and has the correct air flow. With the dryer running and the Air Switch closed, 24 VAC is supplied to the normally closed upper manual reset Overtemp Thermostat on the gray wire and changes to the black wire out of switch and then changes to red wire and goes to the 1.5 amp in-line fuse that protects the Upper Ignition Controller (GREY BOX). With 24 VAC now supplied to the Upper Ignition Controller (GREY BOX) it will then send high voltage to the Spark Ignition Electrode via the High Voltage Lead Wire (this lead looks like an automotive spark plug wire). The Ignition Control Module (GREY BOX) simultaneously sends 24VAC to the Gas Valve Coil which open the Gas Valve and allows gas to pass through to the main burner. When ignition occurs the high voltage sparking stops and if Ignition Control Module (GREY BOX) gets a flame sense signal it will allow gas valve coil to remain energized and continue burner operation. If ignition does not occur, the Ignition Control Module (GREY BOX) will spark for 10 seconds before locking out.

Manual Reset Safety Shutoff Over-Temperature Thermostat

Top Dryer Used For This Example

This thermostat is manually reset by pushing in the red button. The Over Temperature Thermostat is a safety backup for the entire Heat Circuit and located in the recirculation chamber area on the side of the burner housing. If the dryer over heats this Over Temperature Thermostat it opens the line to turn off the heat but leaves the Computer Board lighted and the drive motor powered and turning so the basket will cool down.

Cool Down

Top Dryer Used For This Example

At the preprogrammed time (2 minutes factory setting--adjustable) the Computer Board will open the Gas Relay Contact. This allows the Drive Motor to continue to run but without heat. The gas light on the computer board should not be illuminated anytime the computer is in cool down. This Cool Down period allows the clothing (zippers, snaps, etc.) time to cool down to a temperature that is easily handled by customers.

End of Cycle

Top Dryer Used For This Example

At the end of the cool down, the Computer Board opens the Upper Run Relay, which removes power from the Motor Control Relay (R1) and also removes power to the Drive Motor. The motor light on the computer board should no longer be illuminated. The Drive Motor and tumbler stops and the Computer Board display now flashes until the dryer loading door is opened. Once the dryer loading door is opened to remove the clothing the display goes back to vend price.

50 Hz Parts

Key	Part Number	Description	Quantity
7	8711-008-002	Transformer	1
8	9857-140-001	Ignition Control	2
9	9631-403-008	Wire Assembly High Voltage Upper	1
10	9631-403-009	Wire Assembly High Voltage Lower	1
11	5192-286-018	Relay Power	1
12	9183-030-002	Filter, EMI	1
13	9376-296-004	Motor	2
*	9627-867-001	Harness-Ignition Control, Upper	1
*	9627-867-002	Harness-Ignition Control, Lower	1
*	9627-864-002	Harness Motor Extension	2
*	9506-191-001	Wiring Label Schematic/Diagram	1
*	9506-190-001	Wiring Label Schematic	1
*	9506-189-001	Wiring Label Diagram	1
*	8514-136-001	Owner's Manual	1
*	8220-062-008	Wire Assy, BLK, 11"	1
*	8220-062-034	Wire Assy, Wht 11"	1
*	8220-065-006	Wire Assy, BLK/RED 11"	1
*	8220-065-007	Wire Assy, BLK/BLU 11"	2
*	8653-039-000	Connector-Wire, Inline 1/4	2
*	8640-276-006	Nut-Wire Connector, #72B, Blue	4
*	8507-230-003	Instructions, Transformer Connect	1

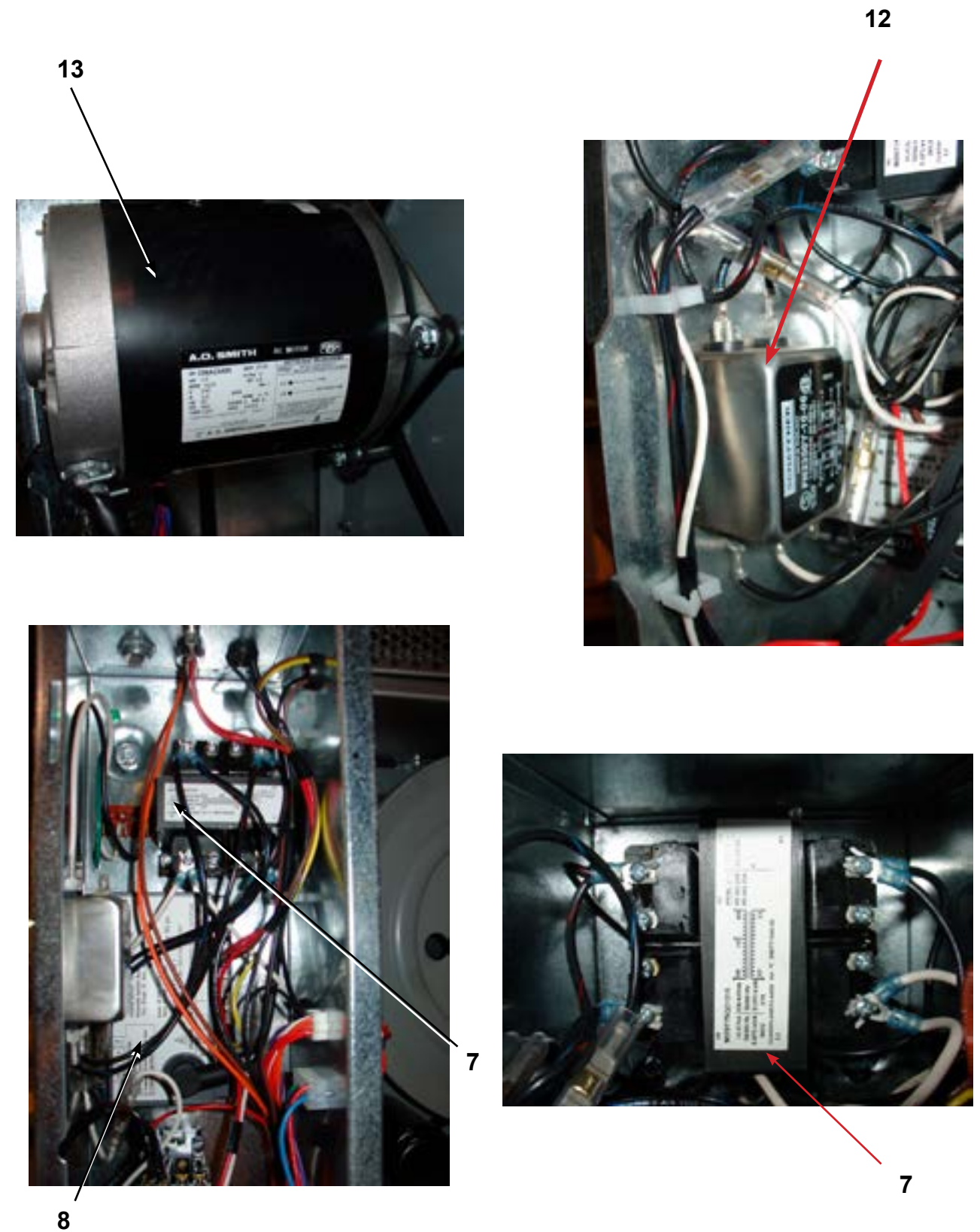

DDAD30KC_-59_ Gas Control Parts

Key	Part Number	Description	Quantity
3	9732-162-001	Kit-Honeywell VR86 Valve Flange.....	4
*	9791-001-001	Adapter Assembly - Gas Inlit.....	1
2	9857-132-004	Gas Control Valve.....	2



2

3

DDAD30KC_-39_ 50Hz

Key	Part Number	Description	Quantity
*	8502-698-001	Label - Aussie Warning.....	1
*	8502-699-001	Label - AUSTGASSAPPROVALBADGE.....	1
*	8507-298-001	Instructions - Aussieaddendum.....	1
*	8514-135-001	Booklet - Owners.....	1
*	9866-004-009	Drawer Ass'y - Lint, up/low (AusCoin).....	1
*	9435-003-011	Overlay - Drawer Front, up/low	

DDAD30KC--39(CR/CP)
DDAD30KC--59(CR/CP)

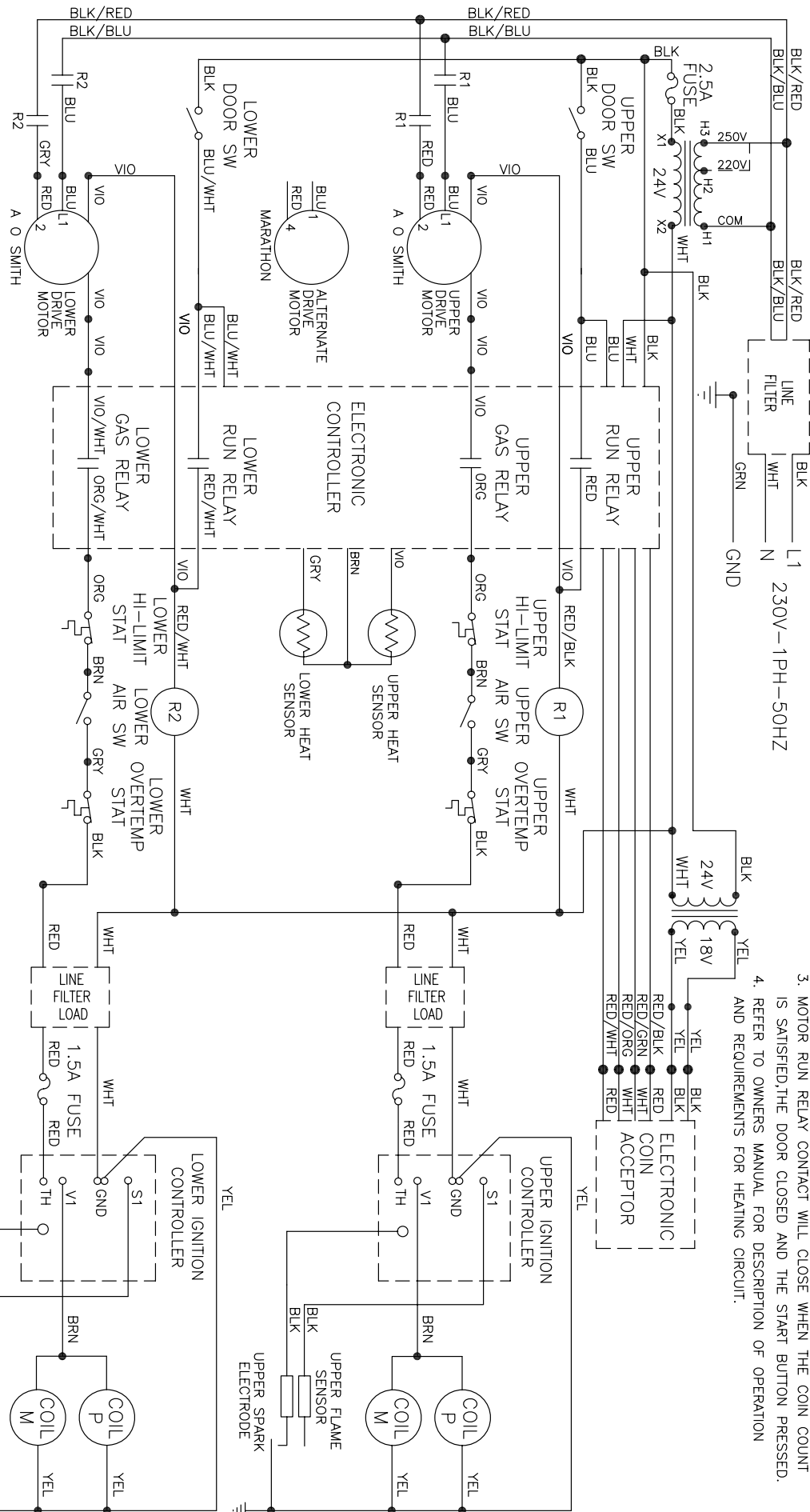

IMPORTANT: RETAIN THIS ELECTRICAL SCHEMATIC FOR SERVICE.

NOTES: 1. ELECTRONIC COIN ACCEPTOR-N.O., CLOSED WHEN COIN INSERTED

2. DOOR SWITCHES-N.O., CLOSED WHEN DOOR IS CLOSED.

3. MOTOR RUN RELAY CONTACT WILL CLOSE WHEN THE COIN COUNT IS SATISFIED, THE DOOR CLOSED AND THE START BUTTON PRESSED.

4. REFER TO OWNERS MANUAL FOR DESCRIPTION OF OPERATION AND REQUIREMENTS FOR HEATING CIRCUIT.

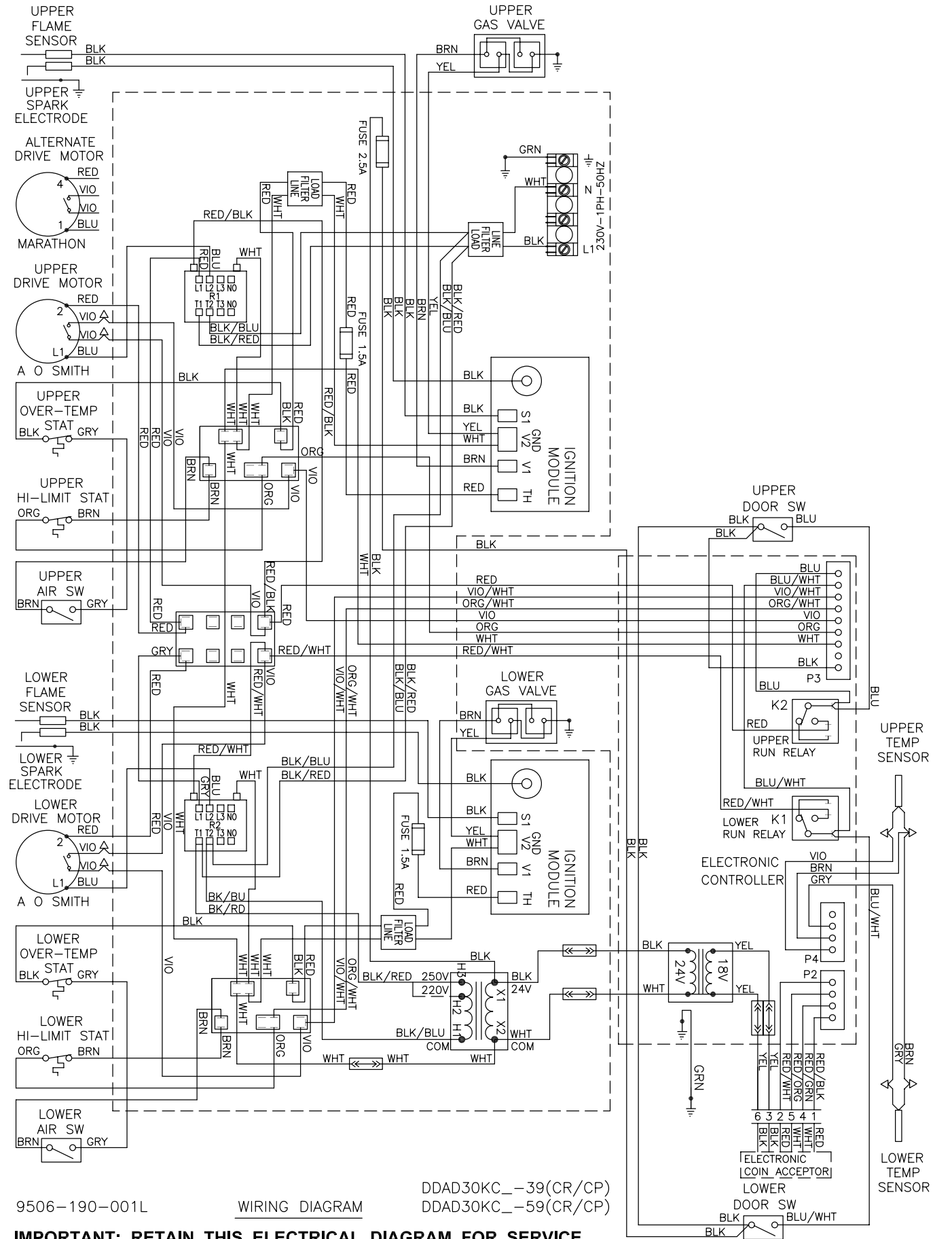

9506-190-001L

WIRING DIAGRAM

DDAD30KC--39(CR/CP)
DDAD30KC--59(CR/CP)

IMPORTANT: RETAIN THIS ELECTRICAL DIAGRAM FOR SERVICE.

Part # 8533-061-0001 11/13

Dexter reserves the right to change part numbers and/or specifications without notice. Reproduction of this manual in any form without express written permission is forbidden.