





***DEXTER***  
***LAUNDRY***









# Dexter Commercial OPL Stack Washer Dryer T-750

Parts & Service Manual

# Equipment Safety Warnings

## Symbols and Terminology Used in this Equipment

 <b>DANGER</b>	Indicates an imminently hazardous situation, which if not avoided, will result in death or serious injury.
 <b>WARNING</b>	Indicates a potentially hazardous situation, which if not avoided could result in death or serious injury.
 <b>CAUTION</b>	Indicates a potentially hazardous situation which, if not avoided, may result in minor or moderate injury. It may also be used to alert against unsafe practices. Minor burns, pinch points that result in bruises and minor chemical irritation.
<b>NOTICE</b>	Indicates information or a company policy that relates directly or indirectly to the safety of personnel or protection of property.
	This is the user caution symbol. It indicates a condition where damage to the equipment resulting in injury to the operator could occur if operational procedures are not followed. <b>TO REDUCE THE RISK OF DAMAGE OR INJURY, refer to accompanying documents; follow all steps or procedures as instructed.</b>
 <small>©1998 HCL, Inc. 800-748-0241 No. 80198-00</small>	This is the electrical hazard symbol. It indicates that there are <b>DANGEROUS HIGH VOLTAGES PRESENT</b> inside the enclosure of this product. <b>TO REDUCE THE RISK OF FIRE OR ELECTRIC SHOCK, do not attempt to open the enclosure or gain access to areas where you are not instructed to do so. REFER SERVICING TO QUALIFIED SERVICE PERSONNEL ONLY</b>
	<b>Caution!</b> There are sharp edges on various sheet metal parts internal to the enclosure. Use safety consciousness when placing or moving your hands while working in the interior of this equipment.
	<b>Caution!</b> To reduce the risk of damage to the Water Inlet Valve, do not supply inlet water with a temperature that exceeds 70° C.  <b>Caution!</b> To reduce the risk of fire or explosion, do not operate this equipment in any hazardous classified (ATEX) environment.

---

# Equipment Safety Warnings

## Symbols and Terminology Used in this Equipment



**Warning! Do not operate equipment if door glass is damaged in any way.**



**Warning! Keep clear of rotating parts.**



**Prohibited! Do not enter this equipment or space.**



**Prohibited! Do not step or stand on this equipment.**



**Prohibited! Do not operate without all guards and covers in place.**









**Prohibited! Do not operate without all guards and covers in place.**



**Prohibited! Do not wash clothing impregnated with flammable liquids (petrochemical).**







**Prohibited! Do not allow children to play in or around equipment.**

	<p>Indicates an imminently hazardous situation, which if not avoided, <b><u>will result</u></b> in death or serious injury.</p>
	<p>Indicates a potentially hazardous situation, which if not avoided <b><u>could result</u></b> in death or serious injury.</p>
	<p>Indicates a potentially hazardous situation which, if not avoided, <b><u>may result</u></b> in minor or moderate injury. It may also be used to alert against unsafe practices. Minor burns, pinch points that result in bruises and minor chemical irritation.</p>
<p><b>NOTICE</b></p>	<p>Indicates information or a company policy that relates directly or indirectly to the safety of personnel or protection of property.</p>
	<p>This is the user caution symbol. It indicates a condition where damage to the equipment resulting in injury to the operator could occur if operational procedures are not followed. <b>TO REDUCE THE RISK OF DAMAGE OR INJURY, refer to accompanying documents; follow all steps or procedures as instructed.</b></p>
	<p>This is the electrical hazard symbol. It indicates that there are <b>DANGEROUS HIGH VOLTAGES PRESENT</b> inside the enclosure of this product. <b>TO REDUCE THE RISK OF FIRE OR ELECTRIC SHOCK, do not attempt to open the enclosure or gain access to areas where you are not instructed to do so. REFER SERVICING TO QUALIFIED SERVICE PERSONNEL ONLY</b></p>
	<p><b>Caution! To reduce the risk of fire or explosion, do not operate this equipment in any hazardous classified (ATEX) environment.</b></p>



## WARNING

	<ul style="list-style-type: none"><li>• All washers must be installed in accordance to all applicable electrical, plumbing and all other local codes.</li><li>• These installation and operation instructions are for use by qualified personnel only. To avoid injury and electrical shock, do not perform any servicing other than that contained in the installation and operation instructions, unless qualified.</li></ul>
	<p>Do not install washers in an explosive atmosphere.</p>
	<ul style="list-style-type: none"><li>• Care must be stressed with all foundation work to ensure a stable unit installation, eliminating possibilities of excessive vibration.</li><li>• Foundation must be level within 13 mm to ensure proper washer operation.</li></ul>
	<p>Do not operate washer if door glass is damaged in any way.</p>
	<p>Do not wash clothing impregnated with flammable liquids (petrochemical).</p>



## WARNING



**Children should be supervised to ensure they do not operate or play in or around equipment.**







**Keep all panels in place to protect against electrical shock and injury and add rigidity to washer.**

**This appliance is not intended for use by persons (including children) with reduced physical, sensory or mental capabilities, or lack of experience and knowledge, unless they have been given supervision or instruction concerning use of the appliance by a person responsible for their safety.**

**A washer should not be allowed to operate if any of the following occur:**

- **Excessive high water level.**
- **Machine is not connected to a properly earthed circuit.**
- **Door does not remain securely locked during the entire cycle.**
- **Vibration or shaking from an inadequate mounting or foundation**

	<p><b>Warning! Do not operate equipment if door glass is damaged in any way.</b></p>
	<p><b>Warning! Keep clear of rotating parts.</b></p>
	<p><b>Prohibited! Do not enter this equipment or space.</b></p>
	<p><b>Prohibited! Do not step or stand on this equipment.</b></p>
	<p><b>Prohibited! Do not operate without all guards and covers in place.</b></p>
	<p><b>Prohibited! Do not operate without all guards and covers in place.</b></p>
	<p><b>Prohibited! Do not wash clothing impregnated with flammable liquids (petrochemical).</b></p>
	<p><b>Prohibited! Do not allow children to play in or around equipment.</b></p>

	<p><b>Prohibited! Do not attempt to open, touch, or proceed before referring to the manual or unless qualified.</b></p>
	<p><b>Mandatory! Read all supporting documentation before operating or maintaining equipment.</b></p>
	<p><b>Mandatory! Disconnect power before servicing equipment.</b></p>
	<p><b>Mandatory! Lock out and tag out before servicing this equipment.</b></p>
	<p><b>Mandatory! Disconnect water supply before servicing equipment.</b></p>
	<p><b>Mandatory! Children should be supervised to ensure they do not operate equipment.</b></p>

# Dexter Safety Guidelines



**These washers are equipped with devices and features relating to their safe operation. To avoid injury or electrical shock, do not perform and service, unless qualified to do so.**

## FOR SAFETY

1. Always shut off power and water supply and also discharge capacitors before servicing.
2. Do not overload the washer.
3. Do not attempt to open door if cylinder is in motion or contains water.
4. Do not mechanically force or override door lock in any way.
5. Do not bypass any safety devices of this washer.
6. Do not use volatile or flammable substances in or near this washer.
7. Keep all panels in place. They protect against shock and injury and add rigidity to the washer.

### **A machine should not be allowed to operated if any of the following occur:**

- Excessively high water level.
- Machine is not connected to a properly grounded circuit.
- Loading door does not remain securely locked during the entire cycle.
- Vibration or shaking from an inadequate mounting or foundation.

To activate your warranty, be sure to return your red warranty form to the factory. Please have serial number and model ready when calling for assistance.

# Table of Contents

## **Section 1:**

Specifications, Mounting Dimensions	
Specifications.....	13 - 14
Dimensions.....	15 - 16

## **Section 2:**

Installation & Operating Instructions	
Washer Installation .....	18
Electrical Connections & Fusing Requirements .	19
Dryer Installation.....	20
Dryer Electric, Gas and Venting.....	21 - 22
Washer Operating Instructions.....	23 - 24
Dryer Operating Instructions.....	24 - 25

## **Section 3:**

Washer and Dryer Programming Instructions	
Wash Cycle Programming.....	28 - 31
Rapid Advance Mode.....	32
Dryer Programming.....	39 - 45

## **Section 4:**

Dryer Service, Troubleshooting and Schematics	
Dryer Service Procedures.....	48 - 54

## **Section 5:**

Dryer Control Fault Codes.....	56
Dryer Troubleshooting Tips.....	57 - 60
Dryer Schematics 60hz.....	65 - 66

## **Section 6:**

Dryer Parts Data.....	68 - 84
-----------------------	---------

## **Section 7:**

50hz Gas Dryers	
50hz Dryer Parts.....	88 - 91
50hz Dryer Schematics.....	92 - 93

## **Section 8:**

Washer Service and Troubleshooting	
Front Panel Removal .....	97
Back Panel Removal.....	97
Drain Valve Access.....	97
Drain Valve Cleaning .....	97

Detergent Dispenser .....	97
Vacuum Breaker/Air Gap.....	97
Water Valves .....	98
Door Lock Assembly Operation .....	99
Adjustment for Door Lock Assembly.....	99 - 100
Adjusting the Loading Door .....	101
Loading Door Removal .....	101
Loading Door Hinge Removal.....	101
Loading Door Disassembly .....	102
Loading Door Reassembly .....	102
Control Panel Name Plate Decal .....	102
Name Plate Removal .....	102
Re-Installation of Name Plate.....	102
Bolt Torque Chart.....	102
Tub Back, Bearing and Cylinder Assembly .....	103
Basket Pulley, Bearing Housing, Water Seals & Tub Back .....	104
Control Mounting Trough.....	106
Main Data Communication Cable.....	106
Circuit Breaker/Fuse .....	106
Main Control Printed Circuit Board.....	106
PCB Transformer Step Down.....	106
Controls Transformer.....	106
Main Relay Printed Circuit Board .....	106
LED Printed Circuit Board Temperature & Start Display Push Button .....	106
Add Bleach LED .....	107
Power Connection Terminal Block .....	107
Pressure Switch .....	108 - 109
Delta Variable Frequency Drive .....	110
Delta VFD Motor Leads.....	110
Delta VFD Dynamic Braking Resistors .....	110
Delta VFD Cooling Fan .....	110
Washer Trouble Shooting and F - Codes...111-120	

**Section 9:**

Washer Electrical & Wiring Schematics	
Start Circuit .....	122
Fill Circuit .....	122 & 123
Wash Circuit .....	123
Drain, Rinse 1 & 2 & Final Rinse Circuit .....	123

Extract Circuit.....	123
Thermoactuator and Shake Out Circuit.....	124
End of Cycle Circuit .....	124
Motor Winding Resistances.....	124
Washer Electrical & Wiring Schematics 60hz .....	126 - 127
.....	150 - 151

**Section 9:**

Washer Parts Data	
SWD Accessories.....	130
Rear View Access Parts .....	132
Cabinet and Front Panel Group .....	135
Cylinder, Seals & Bearings Parts .....	136
Door Lock Parts .....	138 - 139
Loading Door Parts .....	140 - 141
Drain Valve Group Parts .....	142
Water Inlet Parts .....	143
Chassis and Drain Parts.....	144
Electrical Components .....	146 - 148
Labels.....	149

**Section 10:**

50hz Washer Schematics .....	154 - 155
------------------------------	-----------

**Section 11:**

Maintenance Dryer.....	158
Maintenance Washer.....	159

---

# **Section: 1**

Washer and Dryer

Specifications and  
Mounting

## Stacked Washer Dryer Models

<b>Stacked Model Designation</b>	<b>Washer \ Dryer Model #</b>	<b>Electrical Spec: Circuit Breaker / Running Amps / Wire Size/ Option</b>
<b>SN0750NC-16EP2R-SWKCG-USX</b>  <b>9999-705-001</b>	<b>DNS050NC-11EB1R-SWBCG-USA</b>	208-240/60/1, Single 2 Wire + Ground
	<b>WNS750XA-12EV2X-SWKCG-USX</b>	208-240/60/1or3, Single 2 Wire + Ground, 3 Phase 3 Wire plus Ground
<b>SN0750NC-39XP2R-SWKCG-VRX</b>  <b>9999-705-002</b>	<b>DNS050NC-39XB1R-SWKCG-VRX</b>	230-240/50/1, Single 2 Wire + Ground,
	<b>WNS750XA-39XV2X-SWKCS-VRX</b>	230-240/50/1or3, Single 2 Wire + Ground
<b>SN0750NC-39XP2R-SWKMS-VRX</b>  <b>9999-705-009</b>	<b>DNS050NC-39XB1R-SWKSS-VRX</b>	208-240/60/1, Single 2 Wire + Ground, States Quarter Acceptor
	<b>WNS750XA-39XV2X-SWKSS-VRX</b>	208-240/60/1or3, Single 2 Wire + Ground, 3 Phase 3 Wire plus Ground US
<b>SC0750NC-39XC2R-SWBMS-VRX</b>  <b>9999-704-014</b>	<b>DNS050NC-39XC1R-SWBCS-VRX</b>	230-240/50/1, Single 2 Wire + Ground,
	<b>WNS750XA-39XC2X-SWBMS-VRX</b>	230-240/50/1or3, Single 2 Wire + Ground
<b>SN0750NC-16EP2R-SWKCS-USX</b>  <b>9999-705-012</b>	<b>DNS050NC-11EB1R-SWKCS-USX</b>	208-240/60/1, Single 2 Wire + Ground, States Quarter Acceptor
	<b>WNS750XA-12EV2X-SWKCS-USX</b>	208-240/60/1or3, Single 2 Wire + Ground, 3 Phase 3 Wire plus Ground

---

## Washer Specifications:

Dry Weight Capacity	50lbs	(22.7 kg/185.5L)
Cylinder Diameter	30"	(76 cm)
Cylinder Depth	16"	(41 cm)
Cylinder Volume	6.5 cu ft	(185.5 l)
Floor to Door Bottom	16"	(40.61 cm)
Door Opening	19.25"	(48.9 cm)

### Speeds G-Force (RPM)

High Extract Speed	200 G	685 RPM
Intermed. Extract Speed	60 G	375 RPM
Washing Speed	.96	43 RPM
Motor Size	3 HP	2.2 KW

### Electrical

Electrical Phase	Single or Three
Electrical Voltage (60 Hz)	208-240
Electrical Running (Amps)	8.4
Circuit Protection (Amps)	20 amp
Electrical Wire Size	12 gauge
Electrical Service (Single)	2 wire + ground
Electrical Service (Three)	3 wire + ground

### Water

Water Inlet Size	3/4"	(19mm)
Flow Rate (per min)	9 gal	(34.1 L)
Pressure (min/max)	30-120 psi	(207-827 Kpa)
Drain Diameter (O.D.)	3"	(7.61 cm)
Floor to Center of Drain	6 5/8"	(16.82 cm)

### Installation Recommendations

Clearance Between Machines	1/2 (min)	(1.31 cm)
Clearance Behind Machines	24" (min)	(61.0 cm)
Concrete Thickness	8" (min)	(230.3 cm)

### Approvals\*\* ETL

### Washer/Cabinet Dimensions

Height - in (cm)	47 1/4"	(120.02 cm)
Width - in (cm)	34.5"	(90.17 cm)
Depth - in (cm)	44 1/2"	(113.03 cm)

---

## Dryer Specifications:

Dry Weight Capacity	50 lbs	(13.6 kg)
Cylinder Diameter	32 1/2"	(82.5 cm)
Cylinder Depth	33"	(83.8 cm)
Cylinder Volume	15.8 cu ft	(447.4 l)
Floor to Door Bottom	55 1/8"	(140.02 cm)
Door Opening	25 5/8"	(65.1 cm)

### Energy Data

Gas Models	60Hz - 108,000 BTU/hr	(31.7kW)
	50Hz- 96,000 BTU/hr	(28.3kW)

### Electric Models See Below

Electrical Spec: (Voltage/Hz/Phase ) Circuit Breaker / Running Amps / Wire Size

### Gas

-11 (208-240V/60Hz/1, 2 wire + ground) 15 Amp./8 Amps./12 gauge  
-39 (220-240V/50Hz/1, 2 wire + ground) 15 Amp./8 Amps./3.5 mm2

Tumble Speed	45 RPM	
Motor Blower	1/2 HP	0.38kW
Motor Tumbler	2 hp	1.5kW
Air flow - cfm (M3/min)	60HZ-650	18.4 m3/min
Air flow - cfm (M3/min)	50HZ-510	14.4 m3/min
Gas Supply Connection	0.5"	(12.7mm)
Natural Gas (water column)	5-8"	(12.7 - 20.3cm)
L.P. Gas Supply (water column)	11.5 - 14"	(29.2cm)
Operating (water column Natural)	3.5"	
Operating (water column Lp)	11"	(29.2cm)
Make-Up Air	1.0 sq ft	(929 sq cm)
Exhaust Size - in (cm)	8"	(20.3cm)
	Maximum Length with (2 elbows) 14ft.	

### Total Shipping Dimensions

Height - in (cm)	91.625"	(232.7cm)
Width - in (cm)	35.875"	(91.1cm)
Depth - in (cm)	63.5"	(161.3cm)
Weight	1650 Lbs.	(748.4Kg.)

# Machine Dimensions:

## T-750 SMD INDUSTRIAL STACK WASHER/DRYER MOUNTING DIMENSIONS

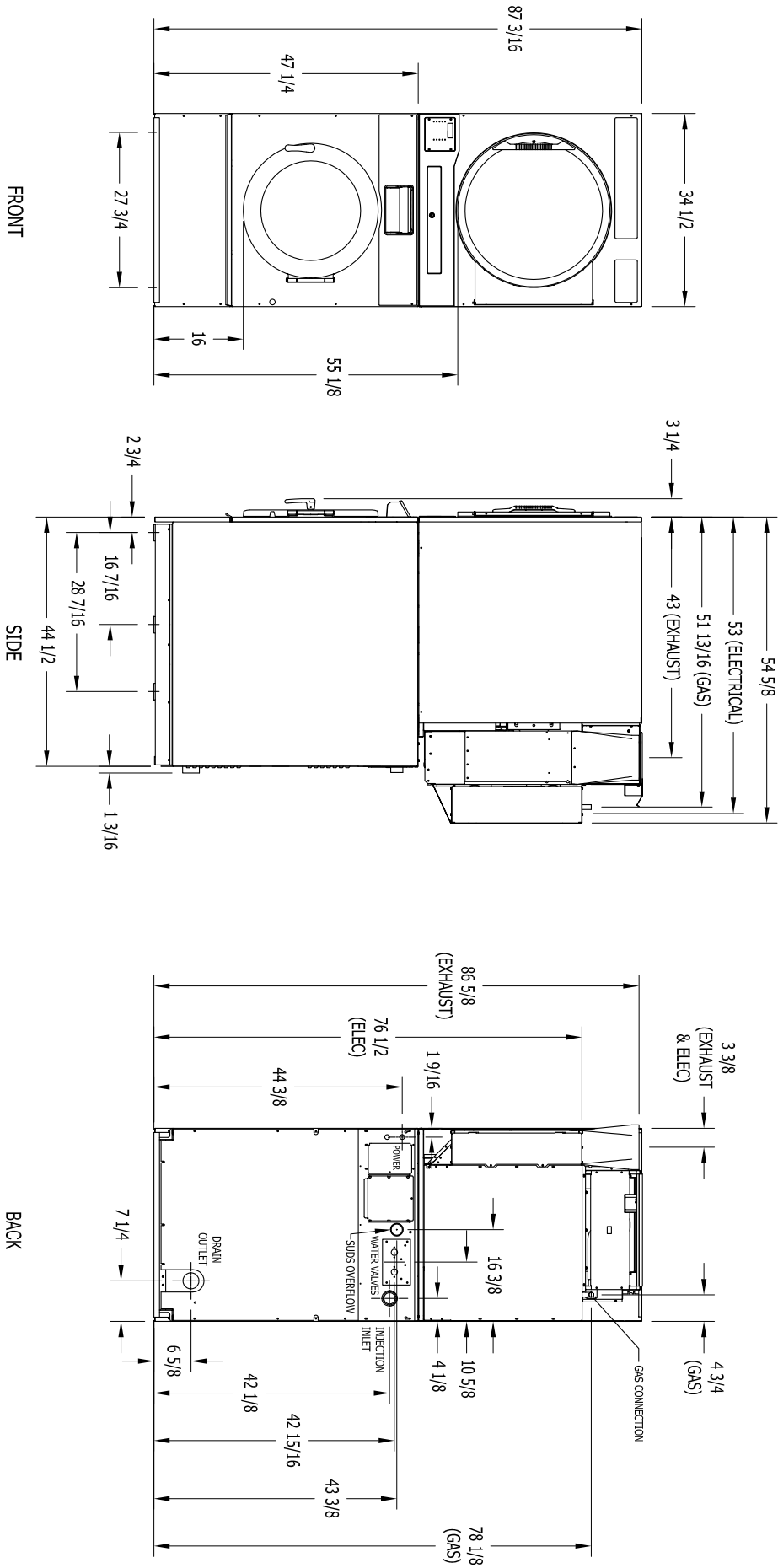

# SWD Mounting Pad Dimensions

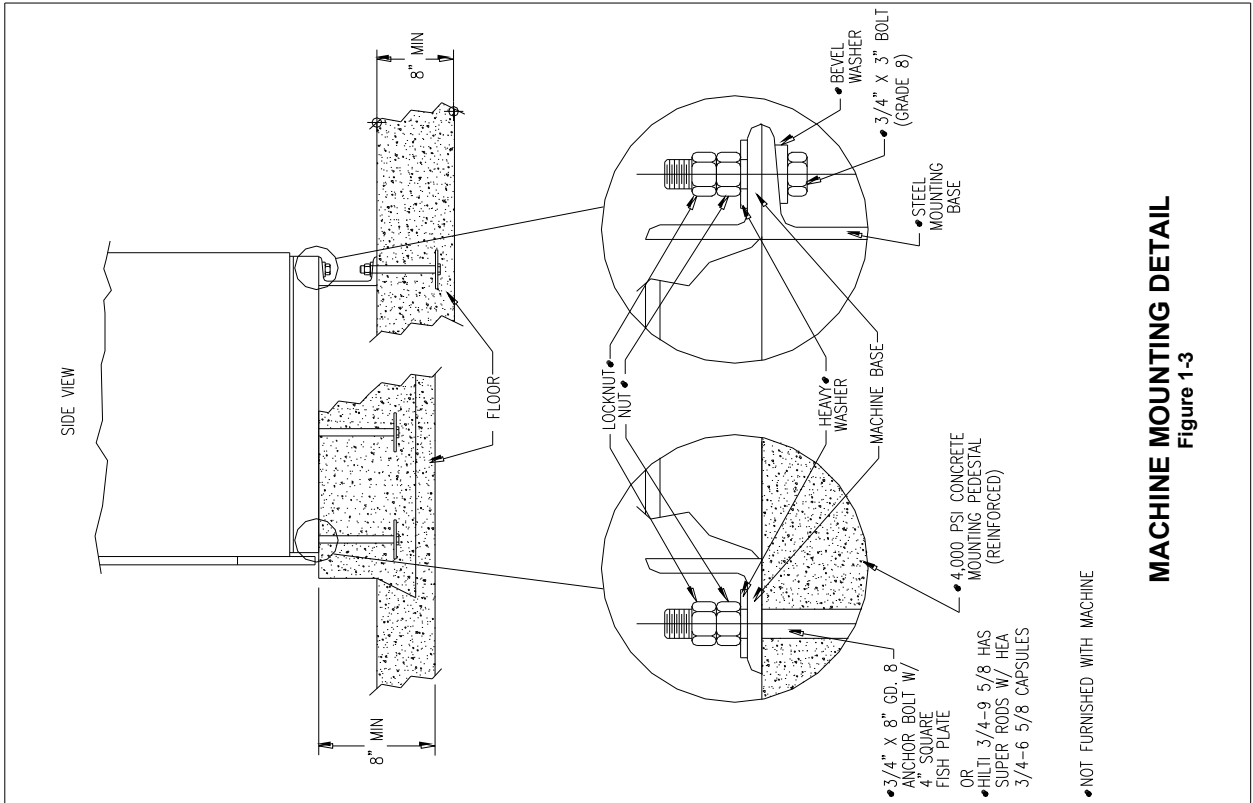

3/4" X 8" GD. 8 BOLTS  
HEADED BY 4" SQ. FISH PLATE OR EQUIV.  
OR  
'HILTI' ADHESIVE ANCHORING SYSTEM.  
USE HILTI 'HEA' 3/4-6 5/8 ADHESIVE CAPSULES  
AND HILTI 'HAS' SUPER RODS 3/4-9 5/8  
FOR MORE INFORMATION CALL  
HILTI CUSTOMER SERVICE  
1-800-879-8000

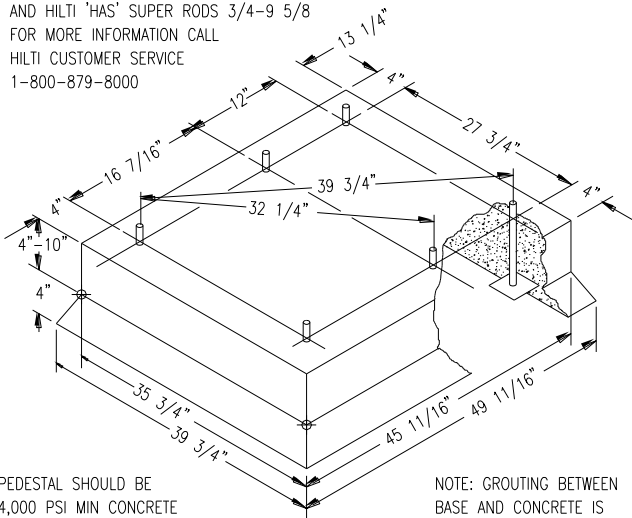

## CONCRETE PEDESTAL MOUNTING

Figure 1-1

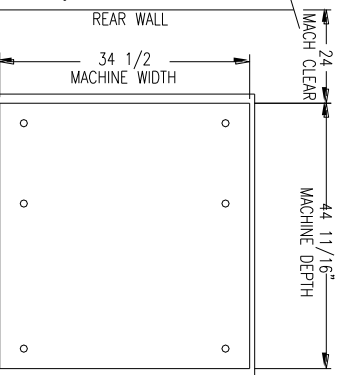
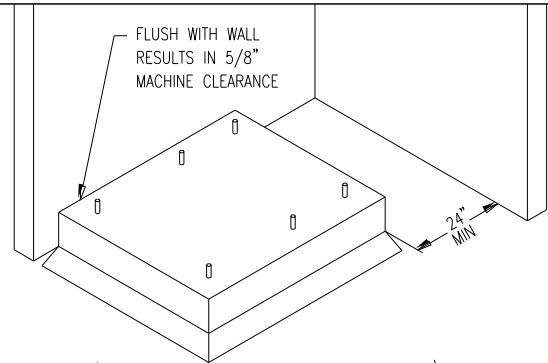

## FLOOR OUTLINE

Figure 1-2

---

# **Section: 2**

Washer and Dryer  
Installation  
& Operating  
Instructions

---

# Washer Installation

**All washers must be installed in accordance with all local, state and national building, electrical, and plumbing codes in effect in the area.**

## Foundation Requirements

The washer must be securely bolted to a substantial concrete floor, or mounted upon a suitable base which is securely bolted and machine grouted to a substantial concrete floor. Care must be stressed with all foundation work to insure a stable unit, eliminating vibration. All installations must be made on sound concrete floors 8" or thicker. Anchor bolts must be of a quality grade and at least imbedded at minimum of 5" in length and minimum 3/4" diameter.

## Mounting

A concrete pad or steel base which elevates the machine 4 to 6 inches above the floor level. To provide easy access to the loading door, it is recommended to allow a minimum of 24" of clearance behind the rear of the machine for service as is shown. SIX (6) bolts are required to mount the washer to the steel base or concrete pad. Grouting where base or machine makes contact with concrete is REQUIRED to achieve 100% surface contact and for warranty to be honored.

**Note: Premanufactured bases are available from DEXTER factory (see sales dept.)**

## Mounting Bolts

The following pages illustrate the mounting dimensions for the machine and also show a typical concrete pad arrangement.

**NOTE: Mounting bolts should be checked frequently to insure that they remain tight. The machine should be checked with a spinning load to be sure there is no unusual vibration or movement between the machine and the base or floor.**

## Proper Machine Grout Required Installation

Machine grout must be installed between base (if used) and concrete floor on all side rails and crossmembers. If using a base you must grout between base top and machine frame and all side rails and crossmembers.

## Plumbing

Water supply hoses are furnished with each machine. The threaded connections on the hoses are standard garden hose type thread. Separate hot and cold water lines with shut off valves or faucets for inlet hose connections must be provided, maintaining 30 to 120 p.s.i. water flow pressure. Maximum water temperature is 180 degrees.

## Drain

The drain outlet tube at the rear of the machine is 3" outside diameter on models. Adequate fall for this gravity drain must be maintained for proper drainage.

## Protective Film

The machine may have protective adhesive film on the front escutcheon area and the front and side stainless steel panels. The film may be peeled off before putting the machine into service.

## Electrical

Dexter single/three-phase 208-240VAC 60 Hz washing machines are intended to be permanently installed appliances. No power cord is provided. The machine should be connected to an individual branch circuit not shared by lighting or other equipment. The connection should be sheathed in liquid tight flexible conduit, or equivalent, with conductors of the proper size and insulation. A qualified technician should make such connections in accordance with the wiring diagram.

Each unit should be connected to an individual branch circuit not shared by lighting or other equipment. Conductors of the proper size and insulation (suggested size below) should be used.

## To Make Electrical Connections

Disconnect all power to the washer. Remove screw and lift out the cover located in the upper left corner of the machine (as viewed from the back).

- If power is 208-240-3PH-60Hz, connect L1, L2, L3 and ground. If there is a high leg it must be connected to L3. It is highly recommended to use a TVSS. (See Informative inside Washer)
- If power is 208-240-1PH-60Hz, connect L1, L2 and Ground.

NOTE: It is important that the grounding screw next to the power terminal block TB-1 be connected to a good external ground.

## Controls Transformer

The controls transformer is located inside the control trough and steps a range of 208 to 240 volts down to 115 volts. There are two terminals on the controls transformer for the primary (incoming) power. Use the terminal marked "208V" for power supplies between 200 and 215 volts. Use the terminal marked "230V" for power supplies between 216 and 240 volts.

NOTE: transformer must be set at proper tap for proper operation.

## Electrical Connections

Electrical power connections are made to the small terminal block located in the rear of the control trough. The terminal block is accessed by opening the top panel of the machine.

- 1 Phase or 3 Phase connections
- 208-240 volts, 60 Hz.
- 3 wire plus ground
- Suggested Minimum Wire Size -- 12 Ga.

## Fusing Requirements:

Dual element time delay fuse or equivalent breaker of amperage specified below.

- 1 Phase or 3 Phase 20 amp

Rotation in extract as viewed through glass door at front of washer models will be counter- clockwise.

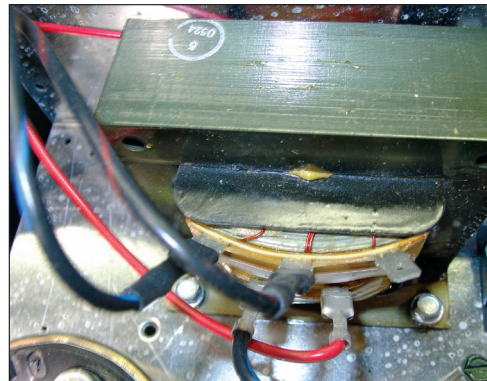
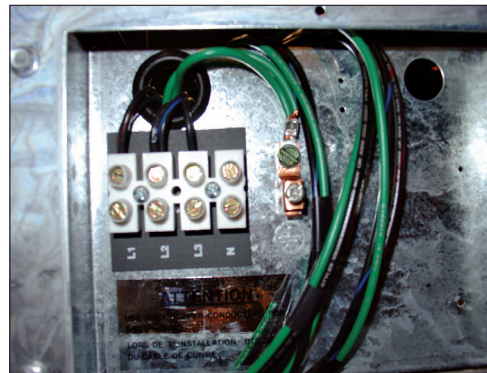

# WARNING

Always disconnect electrical power to the machine before performing any adjustments or service.

# Dryer Installation

All commercial dryer installations must conform with local applicable local codes or in the absence of local codes, with the National Fuel Gas Code ANSI Z223.1A-1988. Canadian installations must comply with current standard CAN/CGA-B149(.1 or .2) Installation Code for Gas Burning Appliances or Equipment, and local codes if applicable. The appliance, when installed, must be electrically grounded in accordance with the National Electric Code, ANSI/NFPA No. 70-1990, or when installed in Canada, with Standard CSA C22.1 Canadian Electrical Code Part 1.

## Installation Clearances:

This unit may be installed at the following alcove clearances.

1. Left side- 0"
2. Right side- 0"
3. Back- 18" (Certified for 1" clearance: however 18" is required to clean, service, and maintain the dryer).
4. Front- 48" to allow use of dryer.
5. Top- Refer to figure labelled "Vertical Clearance Dimensions".
6. Floor- This unit may be installed upon a combustible floor.

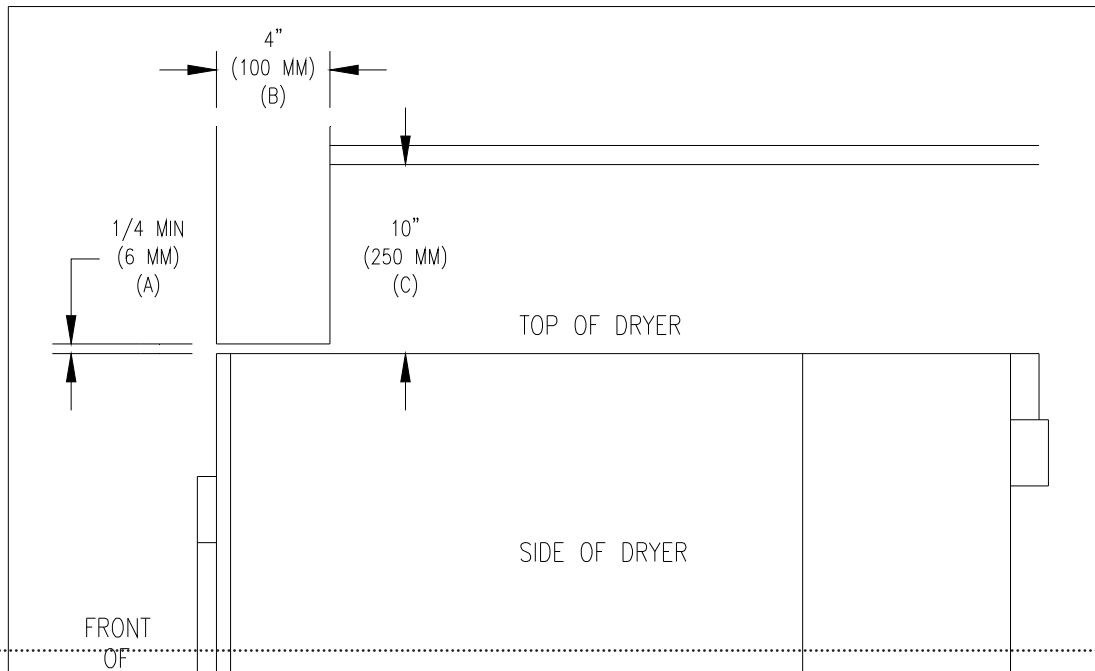

## Makeup Air

Adequate makeup air must be supplied to replace air exhausted by dryers on all types of installations. Provide a minimum of 1 square foot of makeup air opening to the outside for each dryer. This is a net requirement of effective area. Screens, grills or louvers which will restrict the flow of air must be considered. Consult the supplier to determine the free area equivalent for the grill being used.

The source of makeup air should be located sufficiently away from the dryers to allow an even air flow to the air intakes of all dryers. Multiple openings should be provided.

---

**NOTE:** The following considerations must be observed for gas dryer installations where dry cleaners are installed. The sources of all makeup air and room ventilation air movement to all dryers must be located away from any dry cleaners. This is necessary so that solvent vapors will not be drawn into the dryer inlet ducts. Dry cleaner solvent vapors will decompose in contact with an open flame such as the gas flame present in clothes dryers. The decomposition products are highly corrosive and will cause damage to the dryer ducts and clothes loads.

## Electrical Requirements

The electrical power requirements necessary to operate the unit satisfactorily are listed on the serial plate located on the back panel of each dryer. The electrical connection should be made to the terminal board on the rear of the unit using #12 AWG.

It is absolutely necessary that the dryer be grounded to a known ground. Individual circuit breakers for each dryer and washer are required. Use 15A circuit breakers for the 208 - 240VAC dryer. (See Dryer Specification Page for Electric Heated Models)

## Gas Requirements

**GAS REQUIREMENTS.** The complete gas requirements necessary to operate the dryer satisfactorily are listed on the serial plate located on the back panel of the dryer and in the specifications section of this manual. The inlet gas connection to the unit is 1/2-inch pipe thread. However, the size of the piping to supply the dryer should be determined by reference to the National Fuel Gas Code ANSI Z223.1A and consultation with the local gas supplier. An individual gas shutoff valve is recommended for each dryer and may be required by local code (not supplied). A joint compound resistant to the action of liquefied petroleum gases should be employed in making pipe connections. A 1/8-inch NPT plugged tapping, accessible for test gage connection, must be installed immediately upstream of the gas supply connection to the dryer. A drip tee is provided in the unit gas piping to catch dirt and other foreign articles. All pipe connections should be checked for leakage with soap solution. Never check with an open flame. For altitudes above 2,000 feet (610m), it is necessary to derate the BTU input. Contact your local distributor for instructions. L.P. gas conversion kits are available for this dryer. Contact your local distributor.

**CAUTION:** The dryer must be disconnected from the gas supply piping system during any pressure testing of that system. Do not expose the dryer's gas control valve to testing pressure.

## Burner Set-Up

All gas burner manifolds should be checked for proper gas pressure while burning. Dryer burners should be set at 3.5 W.C. for Natural Gas while burner operating.

## Exhaust Installation

Exhausting of the dryer should always be planned and constructed so that minimum air restrictions occur. (Refer to Figure on dryer exhausting). Maximum static back pressure allowed at rear exit of dryer is .3 SBP.

Any restriction due to pipe size or type of installation can cause slow drying time, excessive heat, and lint build up in system and the room.

From an operational standpoint, incorrect or inadequate exhausting can cause cycling of the high limit thermostat which shuts off the main burners and results in inefficient drying.

Individual exhausting of the dryer is recommended. All heat, moisture, and lint should be exhausted outside by attaching a pipe of the proper diameter to the dryer adapter collars and extending it out through an outside wall. This pipe must be very smooth on the inside, as rough surfaces tend to collect lint which will eventually clog the ducts and prevent the dryer from exhausting properly. All elbows must be smooth on the inside. All joints must be made so the exhaust end of one pipe is inside the next one downstream. The addition of an exhaust pipe tends to reduce the amount of air the blower can exhaust. This does not affect the dryer operation if held within practical limits. For the most efficient operation, it is

recommended that no more than 20 feet of straight 8" diameter pipe with two right angle elbows be used for each cylinder. When more than two elbows are used, two feet of straight pipe should be removed for each additional elbow. No more than two right angle elbows should be used to exhaust each cylinder.

If the exhaust pipe passes through a wall, a metal sleeve of slightly larger diameter should be set in the wall and the exhaust pipe passed through this sleeve. This practice is required by some local codes and is recommended in all cases to protect the wall. This type of installation should have a means provided to prevent rain and high winds from entering the exhaust when the dryer is not in use. A hood with a hinged damper can be used for this purpose. Another method would be to point the outlet end of the pipe downward to prevent entrance of wind and rain. In either case, the outlet should be kept clear by at least 24" of any objects which would cause air restrictions.

Never install a protective screen over the exhaust outlet.

When exhausting a dryer straight up through a roof, the overall length of the duct has the same limits as exhausting through a wall. A rain cap must be placed on top of the exhaust and must be of such a type as to be free from clogging. The type using a cone shaped "roof" over the pipe is suitable for this application. Exhausting the dryer into a chimney or under a building is not permitted. In either case there is a danger of lint buildup which can be highly combustible.

Installation of several dryers where a main discharge duct is necessary, will need the following considerations for installation. Whether using the 8" exhaust kit or individual 6" ducts, entrance into the main discharge duct should be at a 45 degree angle in the direction of discharge air flow.

**NOTE:** A small diameter duct will restrict air flow, a large diameter duct will reduce air velocity, both contributing to lint build up, An inspection door should be provided for periodic clean-out of the main duct.

**NOTE:** STATIC BACK PRESSURE should be a maximum of 0.3 in. w.c (7.6 mm w.c) at the rear exhaust outlet of the dryer. If multiple dryers are connected to the common duct, ensure the back draft damper is installed properly.

**NOTE:** The following illustration shows the various round main duct diameters to use with the individual dryer ducts. The main duct can be rectangular or round, provided adequate air flow is maintained. For each individual cylinder the total exhausting (main discharge duct plus duct outlet from the dryer) should not exceed the equivalent of 14 feet and two elbows. The diameter of the main discharge duct at the last dryer must be maintained to exhaust end.

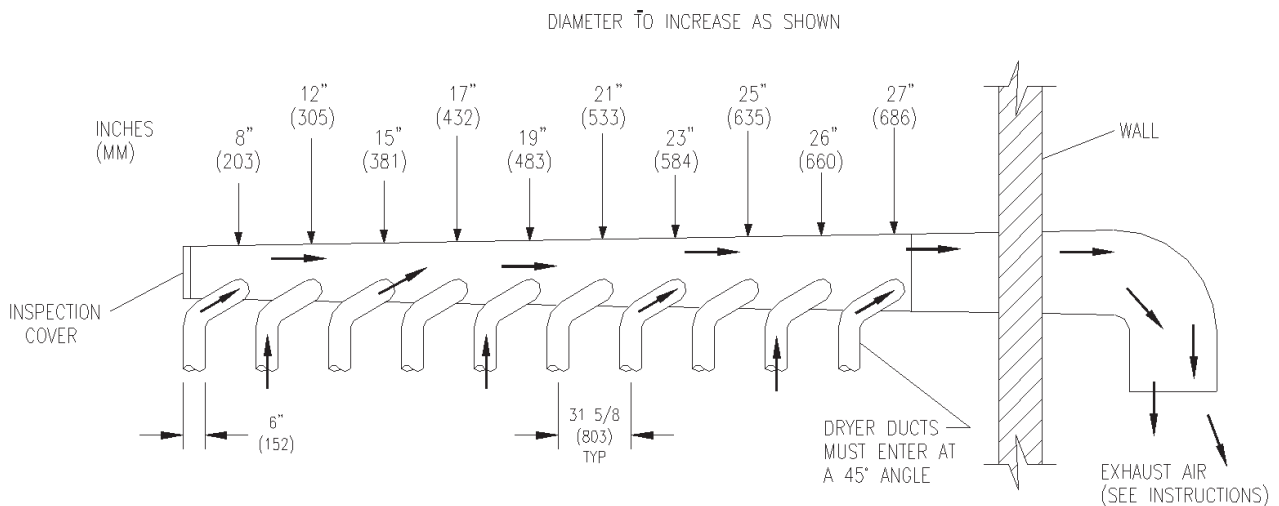

---

# WASHER OPERATING INSTRUCTIONS

## Safety Door Lock

This machine is equipped with a Safety Door Lock that locks the door closed from when the cycle is started until the cycle is complete. The door lock prevents opening the door for up to 3 minutes if the power is interrupted during the cycle.

## Microprocessor

Prior to operation, the micro computer should be set to display the amount of vend price being offered and the cycle to be given to the user. NOTE: Should a power loss occur during cycle and when power returns, P U S H will be displayed in window and customer must push the START button to continue the cycle.

## Starting the Washer

- A. Load the items to be washed in the cylinder and latch the door securely. Be sure clothing does not get caught between the door gasket and tub front when closing the door.

NOTE: To close the door the handle must be in the horizontal position and then moved to the vertical position. After moving the door to the closed position, the handle must be turned down to the vertical position to latch the door for machine operation.

- B. Make the appropriate cycle selection for the wash load by pushing the up and down arrows on the touch pad. Preprogrammed Cycles 1,2,3,4,5, or 6. Each cycle is completely programmable and for instructions see next section in this manual.
- C. To manually add wash compounds, pour low-sudsing powdered detergent into the detergent dispenser on front of the machine. Rinse conditioners may also be added to the dispenser. The correct location of each is shown on the dispenser lid.
- D. To manually add bleach in Rinse, pour bleach in opening. Bleach light will come on during the wash bath only (location shown on dispenser lid) in top or front of washer.
- E. To start the washer, push the green "Start" button
- F. To pause for an extended soak, push the red Stop button for 1 second. To continue the cycle, push the green Start button.
- G. To stop and clear the wash cycle, hold the red Stop button for 8 to 10 seconds.
- H. If automatic chemical injection systems are being used, make sure that chemical hoses are inserted correctly in the injection port located at rear corner at red cover. Hoses must be inserted long enough to reach down to water trap.

### Detergent Measurements

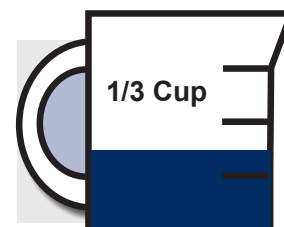

Maxi Load T-750 Washer

---

### **Safety Door Lock**

If power is interrupted the Safety Door Lock delays opening the door until it is safe to do so. If power failure occurs or if power is interrupted during maintenance, it will be necessary to wait 2 to 3 minutes before the door can be opened.

### **End of Cycle**

When the cycle is completed, the washer will stop, the End of Cycle Light will come on, the Buzzer sounds and the loading door will unlock. It can be opened by turning the door handle to the indicated position and pulling. Leave the clothes door open when the machine is not in use helps to eliminate odors that might build up during the wash process.

## **DRYER OPERATING INSTRUCTIONS**

To dry a load of items, you must choose one of the five-programmed dry cycles. Each of these five dry cycles may be modified in two different ways to match your load. Please, refer to the "Permanent Dryer Controller Programming" or "Temporary Dryer Controller Programming" section of this manual.

There are two parts to each dry cycle. The first part is the heating time, which is when the gas valve is cycled on and off according to the temperature setting in the dry cycle program. The second part is the cool down time, which is after the heating part of the dry cycle, and when the cylinder continues to turn, but no heat is applied.

There will always be at least two minutes of cool down time for each dry cycle. The maximum amount of cool down time is 60 minutes.

The five default dry cycle values are shown in the "**DRYER CONTROLLER FACTORY DEFAULT PROGRAM SETTINGS**" table in this manual.

To improve the drying capabilities of this dryer, you should always separate (untangle) the individual articles in your load before using the dryer.

In the following instruction steps, things that are displayed on the 4-digit numerical display will be in "quotation marks" and any touch pad switches on the dryer controller that physically need to be pressed will be in **CAPITAL AND BOLD LETTERS**.

- 1) Place your untangled load into the dryer cylinder and close the dryer loading door. Notice that the dryer controller 4-digit numerical display should show the word "LOAD". If it does not show this word, then press and release the STOP touch pad switch on the dryer controller twice.
- 2) Press and release the UP or DOWN touch pad switch on the dryer controller to select a dry cycle.
- 3) Once the desired dry cycle is selected, press and release the START touch pad switch.

After the dryer controller START touch pad switch is pressed, the dryer cylinder will start rotating and the two-digit total dry cycle time, along with a decimal point, will appear on the dryer controller display.

The time shown on the dryer controller display will count down to the programmed cool down time. At that time, the display will change from the decimal point and two-digit number to a letter "C" and two digits.

The letter "C" represents the cool down portion of the dry cycle. The two digits represent the amount of time remaining in the dry cycle. The two-digit time, shown on the dryer controller display, will count down to zero.

When the time decrements to zero, the dryer controller display will flash the work "donE" and the end of cycle tone will sound.

At that point, the wrinkle free cycle will automatically begin. This cycle will wait two minutes, if the door is not opened or the STOP touch pad switch on the dryer controller is not pressed, and then rotate the cylinder for 10 seconds and stop. This two-minute of idle time and 10 seconds of tumble time will repeat a total of 10 times, at which time the wrinkle free cycle stops. The cylinder will not rotate again until a new dry cycle is started.

During the wrinkle free cycle, the gas valve will not be operated and there will be no heat applied to the load. The word "donE" will also continue to flash and do so even after the wrinkle free cycle is finished. When the dryer loading door is opened, or the STOP touch pad switch is pressed, the word "done" will change to the word "LOAD" on the dryer controller display. The dryer will then be ready for another dry cycle.

During the dry cycle, either pressing the STOP touch pad switch on the dryer controller or opening the dryer loading door will stop the dry cycle and not clear it. If you press the STOP touch pad switch on the controller and then open the dryer loading door, the dry cycle will not be cleared. However, if you open (or open and close) the dryer loading door and then press the STOP touch pad switch on the dryer controller, the present dry cycle will be cleared and the word "LOAD" will appear on the dryer controller display.

There are two jumpers and one push button on the component side of the dryer controller printed circuit board.

## Jumper Options

The jumper located at the lower right side of the circuit board controls whether the controller display shows and operates in the Fahrenheit or Celsius mode. This jumper is labeled as TEMP SELECT and has three pins.

The bottom and middle pins are for Celsius and the top and middle pins are for Fahrenheit, which is indicated by the letter C for Celsius and the letter F for Fahrenheit.

The other jumper, located at the upper right side of the component side of the dryer controller circuit board, is used for choosing either a reversing or non-reversing type of dryer. This jumper is labeled as REV and NON-REV. This jumper must be in the non-reversing position, which are the bottom and middle pins. If the jumper is in the reversing position, the heating part of the dry cycle will not operate properly. The dryer will not reverse direction either.

## Factory Reset

The push button, which is located at the lower middle side of the component side of the dryer controller circuit board, is used to reset all five of the dry cycles to the factory default settings. It is labeled as DEFAULT SETTINGS. Even the dry cycles that have been modified using the permanent programming procedure will be changed back to the factory default settings when using this push button. This push button must be pressed and held for at least three seconds with power applied to the dryer controller circuit board.

DRY CYCLE	COOL DOWN TIME (minutes)	TOTAL CYCLE TIME (minutes)	DRYING TEMPERATURE		DRYER LOAD
			F	C	
1	5	35	180	82	<b>Towels, pads, heavy cotton</b>
2	2	20	170	77	<b>Sheets, blended materials</b>
3	5	25	180	82	<b>Cotton</b>
4	2	20	130	54	<b>Synthetic Materials</b>
5	2	25	175	79	<b>Blended Materials</b>

---

## TRANSIENT VOLTAGE SURGE SUPPRESSORS

Like most electrical equipment your new machine can be damaged or have its life shortened by voltage surges due to lightning strikes which are not covered by factory warranty. Local power distribution problems also can be detrimental to the life of electrical components. We recommend the installation of transient voltage surge suppressors for your new equipment. These devices may be placed at the power supply panel for the complete installation and don't require an individual device for each machine.

These surge protectors help to protect equipment from large spikes and also from small ongoing spikes in the power that occur on a day to day basis. These smaller surges can shorten overall life of electrical components of all types and cause their failure at a later date. Although they can't protect against all events, these protective devices have a good reputation for significantly lengthening the useful life of electronic components.

Electronic Components are helped to have a longer useful life when they are supplied with the clean stable electrical power they like.

We are including the following names and links to a few suppliers of these devices for those who don't currently have a source.

MANUFACTURER	LINK
MCG Surge Protection	<a href="http://mcgsurge.com">mcgsurge.com</a>
Eaton Corporation	<a href="http://eaton.com/us/en-us">eaton.com/us/en-us</a>
Schneider Electric	<a href="http://se.com/us/en">se.com/us/en</a>
Asco Power Technologies	<a href="http://ascopower.com/us/en">ascopower.com/us/en</a>
Emerson Electric Co.	<a href="http://emerson.com/en-us">emerson.com/en-us</a>





---

# **Section: 3**

## Washer and Dryer Programming Instructions

### Bath Cycle Time "ct"

0 to 15 minutes for Prewash, Rinse 1 and Rinse 3 to 15 minutes for Wash and Final Rinse. For the baths that can, if the time is set to zero, then that bath will be eliminated from the cycle.

### Bath Water Temperature "t"

HH – hot, CH – warm, CC – cold, EE – no water. The owner can set the bath default. For the wash bath, the default is over ridden for that cycle by the customer when the temperature is selected.

### Bath Water Level "L"

LO – low The owner can change the displayed value, but for a coin washer only LO will be put into the cycle.

### Bath Delay Fill "dF"

The selections are "d" for delay the bath time until water level is reached or "t" for decrement bath time during the fill.

### Bath Spin Time "S"

0 to 10 minutes for Prewash, Wash, Rinse 1 and Rinse 2 1 to 10 minutes for Final Spin.

### Bath "IS"

The owner can change the displayed value, but for a coin washer only 0 will be put into the cycle.

## Washer 6 Default Cycles (Preset at Factory)

**There are 6 pre programmed baths on the control which are set up at the factory. The formulas for each are shown on the following pages. Each of these 6 programs can be adjusted and saved as the owner needs.**

**Cycle 1: Sheets and Pillowcases (Health Care)**

<b>Bath</b>	<b>Bath Cycle Time (min.)</b>	<b>Water Temp.</b>	<b>Water Level</b>	<b>Delay Fill</b>	<b>Spin Time (min.)</b>	<b>Injection Source</b>
Flush	3	CH	HI	d		
Prewash	2	CH	HI	d		
Wash	7	HH	LO	d		#1(Detergent)
Rinse 1	7	HH	LO	d		#2 (Bleach)
Rinse 2	2	CH	HI	d	1	
Rinse 3	2	CH	HI	d		
Rinse 4						
Final Rinse	4	CH	LO	d	4	#4 (Sour/Soft)

**Cycle 2: Towels / Pads / Diapers (Health Care)**

<b>Bath</b>	<b>Bath Cycle Time (min.)</b>	<b>Water Temp.</b>	<b>Water Level</b>	<b>Delay Fill</b>	<b>Spin Time (min.)</b>	<b>Injection Source</b>
Flush	3	CH	HI	d		
Prewash	2	CH	HI	d		
Wash	7	HH	LO	d		#1 (Detergent)
Rinse 1	1	HH	HI	d		
Rinse 2	7	HH	LO	d		#2 (Bleach)
Rinse 3	2	CH	HI	d	1	
Rinse 4	2	CH	HI	d		
Final Rinse	4	CH	LO	d	5	#4 (Sour/Soft)

**Cycle 3: White Towels (Hotel / Motel)**

<b>Bath</b>	<b>Bath Cycle Time (min.)</b>	<b>Water Temp.</b>	<b>Water Level</b>	<b>Delay Fill</b>	<b>Spin Time (min.)</b>	<b>Injection Source</b>
Flush						
Prewash						
Wash	7	HH	LO	d		#1(Detergent)
Rinse 1	1	HH	HI	d		
Rinse 2	7	HH	LO	d		#2 (Bleach)
Rinse 3	2	CH	HI	d	1	
Rinse 4	2	CH	HI	d		
Final Rinse	4	CH	LO	d	5	#4 (Sour/Soft)

Cycle 4: Guest Laundry (Hotel / Motel / Healthcare)						
Bath	Bath Cycle Time (min)	Water Temp.	Water Level	Delay Fill	Spin Time (min)	Injection Source
Flush	3	CH	HI	d		
Prewash						
Wash	7	HH	LO	d		#6(Detergent/Bleach)
Rinse 1	2	HH	HI	d		
Rinse 2	2	CH	HI	d		
Rinse 3	2	CH	HI	d		
Rinse 4						
Final Rinse	4	CH	LO	d	4	#4 (Sour/Soft)

Cycle 5: Rags and Mops (Hotel / Motel)						
Bath	Bath Cycle Time (min)	Water Temp.	Water Level	Delay Fill	Spin Time (min)	Injection Source
Flush	3	CH	HI	d		
Prewash	2	CH	HI	d		
Wash	2	CH	HI	d		
Rinse 1	7	HH	LO	d		#1 (Detergent)
Rinse 2	2	HH	HI	d		
Rinse 3	7	HH	LO	d		#2 (Bleach)
Rinse 4	2	CH	HI	d	1	
Final Rinse	2	CH	LO	d	5	

Cycle 6: Colored Cotton Linen (Hotel & Food Service)						
Bath	Bath Cycle Time (min)	Water Temp.	Water Level	Delay Fill	Spin Time (min)	Injection Source
Flush	2	CH	HI	d		
Prewash						
Wash	10	CH	HI	d		#1(Detergent)
Rinse 1	7	HH	LO	d		#2 (Bleach)
Rinse 2	2	HH	HI	d	1	
Rinse 3	2	HH	LO	d		
Rinse 4						
Final Rinse	2	CH	LO	d	4	#6 (Sour/Starch)

---

# Washer Programming Instructions

## THERE ARE TWO WAYS TO MODIFY PROGRAMMING OF THE V-SERIES OPL SIX (6) PREPROGRAMMED FORMULAS

**Option 1:** Programming can be accomplished manually using the machine controls or by connecting to the machine control using a PDA (personal digital assistant). For instructions on using a PDA with this washer control and software, please contact your local Dexter distributor. Please read below for manual programming instructions.

The keypad layout for the washer control is shown below.

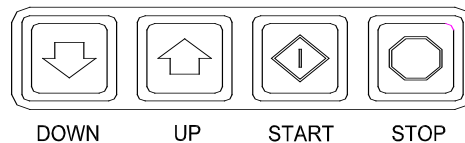

### Option 2: Wash Cycle Manually Programming

1. Turn on the power to the washer.
2. Turn the Run/Program key to the Program position. Display will show "CO" and the "ADD BLEACH" will blink and will continue to blink during the programming mode.
3. Press the "DOWN" or "UP" buttons to select which cycle to alter. When the desired cycle number is displayed, press "START".
4. The display should now show a "b". The "b" and the cycle indicator lights indicate which bath is being selected to alter. Press the "UP" and "DOWN" buttons to select a bath to change and then press "START".

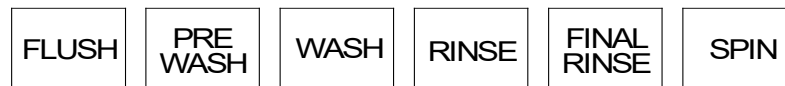

The indicator lights are shown above:

When "RINSE" is selected, "b r1" through "b r4" may be selected.

**There may be multiple rinses that are indicated by br 1, br 2, br 3, and br 4**

5. Each bath can be programmed with the following options. Use the "DOWN" and "UP" keys to select the desired setting and the "START" key to move to the next option.

To exit the programming of a bath, press the "STOP" button once and use the "UP" and "DOWN" keys select another bath. Press the "STOP" button again to select a different cycle to change. To end programming, turn the key to "RUN" position.

## Rapid Advance Mode

To enter the Rapid Advance mode, turn the key CCW. The Rapid Advance setting is not marked next to the key, but turning the CCW until it stops selects this mode. The Rapid Advance mode can be entered from either the Idle mode or during the cycle. If the cycle has not yet started, press the "START" button. To rapid advance to the next step in the wash cycle, push both the "UP" and "START" buttons at the same time. The display will show an "Ad" (advance) in the display. The washer will advance to the next bath segment. The water will drain before the advance will occur and the time displayed may not be accurate.

- Notes:**
- The indicator lights will show to which segment the cycle has been advanced.
  - The cycle will continue in rapid advance mode even if the key is turned to "RUN" and/or removed.
  - Rapid advance cannot skip the final 1- minute tumble of the cycle, and the door lock may remain activated for up to 3 minutes after the cycle has been completed.
  - Chemical 120 volt signals will be lost after Rapid advance Mode has been activated until cycle resets. To exit the Rapid Advance mode, push and hold the STOP button.

## Injection Source Details

The washer control may be programmed to send output signals for a chemical injection system. There is a separate terminal block for connection of the external injection signals. For the injection sources, program codes 0 through 6 are as shown in the table below. Injection signal will trigger a 120 volt reading at rear terminal block for approximately 5-10 seconds and will start to trigger at about 10-seconds after start of fill bath.

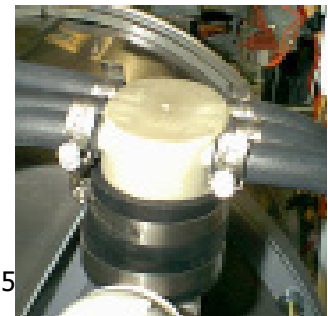
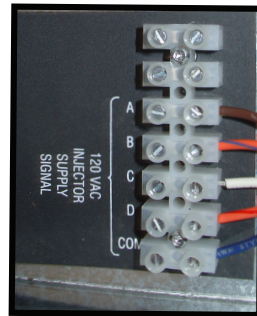

### Dexter Recommended Connections Circuits

Detergent  
Bleach  
Starch  
Sour/Softener

### Controller Programmed Signals

1  
2  
3  
4  
5  
6  
0

### Injection Terminal Block

A  
B  
C  
D  
A and B  
C and D  
None

**NOTE: The Wash Cycle programming mode will automatically exit and return to the Idle mode if no buttons are pushed for one minute.**

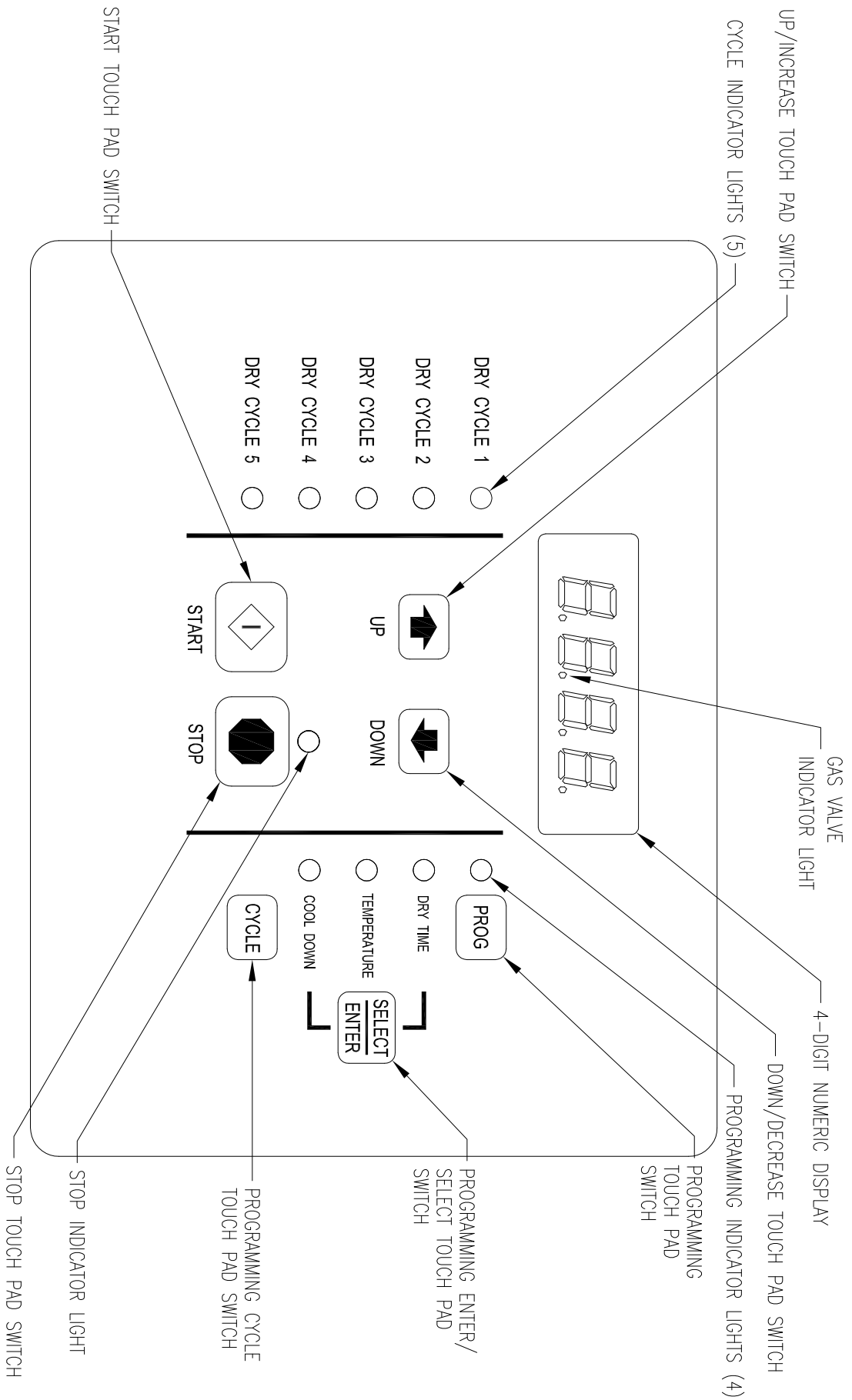

---

## TOUCH PAD DESCRIPTION

### INDICATOR LIGHTS (L.E.D.s)

#### Description

#### Cycle (1 through 5)

These L.E.D.s are on solid when a particular cycle is chosen for operation or programming.

#### Gas Valve

This L.E.D. is part of the 4-digit numeric display and will be on solid during the drying part of a cycle when the gas valve does not need to be on. The L.E.D. will be blinking when the gas valve needs to be on. The L.E.D. will not be on solid or blinking (off) if the cycle is stopped, complete, in cool down, or terminated.

#### Programming

These L.E.D.s are on solid as they are selected during the programming of the dryer controller.

#### Stop

This L.E.D. is on solid when either the STOP button is pressed once or the door is opened during an operating cycle.

### SWITCHES (Pushbuttons)

#### Description

This touch pad switch will increment (increase) dry time, cool down time, and drying temperature. It will also scroll upwards when selecting a dry cycle.

#### UP/INCREASE

##### Down

This touch pad switch will decrement (decrease) dry time, cool down time, and drying temperature. It will also scroll downwards when selecting a dry cycle.

#### DOWN/DECREASE

This touch pad switch allows the dryer controller to enter the permanent programming mode.

#### PROGRAM

This touch pad switch will select one of the three variable parts of the dry cycle (dry time, temperature, or cool down) by sequencing through them. Once one of the variable parts of the dry cycle is chosen and changed, this touch pad switch will enter the new (changed) value into the dry cycle program.

#### SELECT/ENTER

This touch pad switch allows the dryer controller to enter the temporary programming mode.

This touch pad switch allows the dryer controller to enter the Cycles 1 thru 5.



This touch pad switch will stop the dryer during a dry cycle without clearing the present drying cycle if pressed once. If pressed and released twice, consecutively, the present dry cycle will be cleared.

## STOP



This touch pad switch will start the operation of a dry cycle if pressed and released once. Pressing and holding this touch pad switch will display the current temperature of the dryer heat sensor as long as it is held in the depressed position.

## START

### 4-DIGIT NUMERICAL DISPLAY MESSAGES

#### Description

LOAD	This message is displayed after a dry cycle is complete and the dryer loading door has been opened or the STOP touch pad switch on the dryer controller has been pressed and released twice.
donE	This message blinks immediately after completion of the dry cycle and continues to blink until the STOP touch pad switch on the dryer controller is pressed or the dryer loading door is opened.
Prog	This message is displayed when entering the permanent programming mode.
.15	This message appears while the dryer is in the heating time of a dry cycle. The decimal point will blink if the output for the gas valve is on, or remain on constantly if the output for the gas valve is not on. The number represents the total time left in the dry cycle (includes cool down time).
C02	This message appears when the cool down time of the dry cycle is reached. The letter "C" represents the cool down (non-heating) part of the dry cycle. The number(s) after the letter "C" represent(s) the total time remaining in the dry cycle.
F5	This message appears if there is a dryer fault. The letter "F" indicates a fault and the number after the "F" represents the specific fault that has occurred. There are five different faults that can appear (F1 through F5).
rEv	This message is displayed while in the programming mode, to indicate the reversing function during the dry cycle.
nrEv	This message is displayed, while the programming mode, to indicate the nonreversing function during the dry cycle.

## OPERATING INSTRUCTIONS

---

To dry a load of items, you must choose one of the five-programmed dry cycles. Each of these five dry cycles may be modified in two different ways to match your load. Please, refer to the "Permanent Reversing Dryer Controller Programming" or "Temporary Reversing Dryer Controller Programming" section of this manual.

There are two parts to each dry cycle. The first part is the heating time, which is when the gas valve is cycled on and off according to the temperature setting in the dry cycle program. The second part is the cool down time, which is after the heating part of the dry cycle, and when the cylinder continues to turn, but no heat is applied.

There will always be at least two minutes of cool down time for each dry cycle. The maximum amount of cool down time is 60 minutes.

During a reversing dry cycle, the tumbler will rotate in one direction for one minute, decelerate for four seconds, and then rotate in the opposite direction for one minute. This motion will repeat for the duration of the dry cycle. If the controller has a red dot sticker, the amount of reversing time can be set to either one or two minutes. To change the reversing time, the 4-digit numerical display must show "LOAD". Then, press and hold the SELECT/ENTER touch pad switch and then press the UP touch pad switch to set the time to two minutes or the DOWN touch pad switch to set the time to one minute. The buzzer will then beep to indicate the change was successful. The change will be retained even if the power is removed. The factory default is one minute.

The five default dry cycle values are shown in the "REVERSING DRYER CONTROLLER FACTORY DEFAULT PROGRAM SETTINGS" table in this manual.

To improve the drying capabilities of this dryer, you should always separate (untangle) the individual articles in your load before using the dryer.

In the following instruction steps, things that are displayed on the 4-digit numerical display will be in "quotation marks" and any touch pad switches on the dryer controller that physically need to be pressed will be in **CAPITAL AND BOLD LETTERS**.

- 1) Place your untangled load into the dryer cylinder and close the dryer loading door. Notice that the dryer controller 4-digit numerical display should show the word "LOAD". If it does not show this word, then press and release the **STOP** touch pad switch on the dryer controller twice.
- 2) Press and release the **UP** or **DOWN** touch pad switch on the dryer controller to select a dry cycle.
- 3) Once the desired dry cycle is selected, press and release the **START** touch pad switch.

After the dryer controller **START** touch pad switch is pressed, the dryer cylinder will start rotating and the two-digit total dry cycle time, along with a decimal point, will appear on the dryer controller display.

The time shown on the dryer controller display will count down to the programmed cool down time. At that time, the display will change from the decimal point and two-digit number to a letter "C" and two digits.

The letter "C" represents the cool down portion of the dry cycle. The two digits represent the amount of time remaining in the dry cycle. The two-digit time, shown on the dryer controller display, will count down to zero.

When the time decrements to zero, the dryer controller display will flash the work "donE" and the end of cycle tone will sound.

At that point, the wrinkle free cycle will automatically begin. This cycle will wait two minutes, if the door is not opened or the **STOP** touch pad switch on the dryer controller is not pressed, and then rotate the cylinder for 10 seconds and stop. This two-minute of idle time and 10 seconds of tumble time will repeat a total of 10 times, at which time the wrinkle free cycle stops. The cylinder will not rotate again until a new dry cycle is started.

During the wrinkle free cycle, the gas valve will not be operated and there will be no heat applied to the load. The word "donE" will also continue to flash and do so even after the wrinkle free cycle is finished. When the dryer loading door is opened, or the **STOP** touch pad switch is pressed, the word "donE" will change to the word "LOAD" on the dryer controller display. The dryer will then be ready for another dry cycle.

During the dry cycle, either pressing the **STOP** touch pad switch on the dryer controller or opening the dryer loading door will stop the dry cycle and not clear it. If you press the **STOP** touch pad switch on the controller and then open the dryer loading door, the dry cycle will not be cleared. However, if you open (or open and close) the dryer loading door and then press the **STOP** touch pad switch on the dryer controller, the present dry cycle will be cleared and the word "LOAD" will appear on the dryer controller display.

## Jumper Options

There are two jumpers and one push button on the component side of the dryer controller printed circuit board.

The jumper located at the lower right side of the circuit board controls whether the controller display shows and operates in the Fahrenheit or Celsius mode. This jumper is labeled as TEMP SELECT and has three pins.

The bottom and middle pins are for Celsius and the top and middle pins are for Fahrenheit, which is indicated by the letter C for Celsius and the letter F for Fahrenheit.

The other jumper, located at the upper right side of the component side of the dryer controller circuit board, is used for choosing either a reversing or non-reversing type of dryer. This jumper is labeled as REV and NON-REV. This jumper must be in the reversing position, which are the bottom and middle pins. If the jumper is in the non-reversing position, the heating part of the dry cycle will not operate properly. The dryer will not reverse direction.

## Factory Reset

The push button, which is located at the lower middle side of the component side of the dryer controller circuit board, is used to reset all five of the dry cycles to the factory default settings. It is labeled as DEFAULT SETTINGS. Even the dry cycles that have been modified using the permanent programming procedure will be changed back to the factory default settings when using this push button. This push button must be pressed and held for at least three seconds with power applied to the dryer controller circuit board.

DRY CYCLE	DRYER DIRECTION	COOL DOWN TIME (minutes)	TOTAL CYCLE TIME (minutes)	DRYING TEMPERATURE		DRYER LOAD
				F	C	
1	REV.	5	35	180	82	<b>Towels, pads, heavy cotton</b>
2	REV.	2	20	170	77	<b>Sheets, blended materials</b>
3	REV.	5	25	180	82	<b>Cotton</b>
4	NON-REV.	2	20	130	54	<b>Synthetic Materials</b>
5	NON-REV.	2	25	175	79	<b>Blended Materials</b>

---

## **TEMPORARY REVERSING DRYER CONTROLLER PROGRAMMING**

Temporary programming mode will allow the change of the stored dry cycle settings in the dryer controller for one complete dry cycle. After the dry cycle is complete, the default settings that existed before the temporary change are restored. The temporary dry cycle can be stopped and cleared at any time during the dry cycle operation.

To temporarily change a dryer controller cycle, follow the procedures below. Things that are displayed on the 4-digit numeric display will be in "quotation marks". Touch pad switches on the dryer controller that physically need to be pressed will be in **CAPITAL AND BOLD LETTERS**.

If, at any time, you want to escape the temporary programming mode while changing the program settings, you can press the **STOP** touch pad switch on the dryer controller if the 4-digit numeric display is not flashing. The **SELECT/ENTER** touch pad switch on the dryer controller can be pressed and released to enter the flashing value shown on the 4-digit numeric display and allow you to escape.

If you press and release the **STOP** touch pad switch on the dryer controller, when the 4-digit numeric display is not flashing, the temporary changes to the dry cycle program will be cancelled. The stored dry cycle settings that existed before the temporary change will then be restored.

If, at any time, you want to start the temporary dry cycle during the temporary programming mode, press and release the **START** touch pad switch on the dryer controller if the 4-digit numeric display is not flashing. The **SELECT/ENTER** touch pad switch on the dryer controller can be pressed and released to enter the flashing value shown on the 4-digit numeric display and allow you to start the temporary dry cycle. If you start the temporary dry cycle, the 4-digit numerical display will change the total dry time and count down to 0 as the dry cycle progresses.

### **PROCEDURE**

- 1) Make sure the dryer is not in a dry cycle. The 4-digit numeric display on the dryer controller will show "LOAD" when the dryer is not in a dry cycle.
- 2) Press and release the **UP** or **DOWN** touch pad switch on the dryer controller to choose the dry cycle that you want to change (dry cycle 1 through 5). The dry cycle L.E.D. will illuminate to indicate which dry cycle you are choosing. If you press and hold down either the **UP** or **DOWN** touch pad switch, the controller will sequence through the five dry cycles.
- 3) Press and release the **CYCLE** touch pad switch on the dryer controller once you have chosen the dry cycle you want to change. After you press the **CYCLE** touch pad switch, the programming L.E.D. and the dry time L.E.D. will illuminate, the dry cycle L.E.D. will remain illuminated, and the total dry time will be displayed on the 4-digit numeric display.
- 4) Press and release the **UP** or **DOWN** touch pad switch on the dryer controller to change the total cycle time. Once either the **UP** or **DOWN** touch pad switch is pressed, the dry time L.E.D. and the total dry time on the 4-digit numeric display will flash. If you press and hold down either the **UP** or **DOWN** touch pad switch, you will increment (**UP** arrow) or decrement (**DOWN** arrow) through the total dry times available (1 through 60 minutes). This display dry time includes the cool down time along with the heated time. To not change the cool down time, do not press either the **UP** or **DOWN** touch pad switch. Go to the next step.

- 
- 5) Press and release the **SELECT/ENTER** touch pad switch on the dryer controller. Once the **SELECT/ENTER** touch pad switch is pressed and released, the dry time L.E.D. will switch off, the dry cycle L.E.D. and programming L.E.D. will remain on, the temperature L.E.D. will illuminate, and the drying temperature will be shown on the 4-digit numeric display.
  - 6) Press and release either the **UP** or **DOWN** touch pad switch on the dryer controller to change the drying temperature. Each press and release of either the **UP** or **DOWN** touch pad switch will either increase or decrease, respectively, the temperature by five degrees Fahrenheit or three degrees Celsius, depending on how your dryer controller is set up. Once either the **UP** or **DOWN** touch pad switch is pressed, the temperature L.E.D. and the drying temperature on the 4-digit numeric display will flash. If you press and hold down either the **UP** or **DOWN** touch pad switch, you will increment (**UP** arrow) or decrement (**DOWN** arrow) your way through the available drying temperatures (105° Fahrenheit or 41° Celsius, up to 195° Fahrenheit or 90° Celsius). If you do not want to change the drying temperature, do not press either the **UP** or **DOWN** touch pad switch. Go to the next step.
  - 7) Press and release the **SELECT/ENTER** touch pad switch on the dryer controller. Once the **SELECT/ENTER** touch pad switch is pressed and released, the temperature L.E.D. will switch off, the dry cycle L.E.D. and programming L.E.D. will remain on, the cool down L.E.D. will illuminate, and the cool down time will be shown on the 4-digit numeric display.
  - 8) Press and release either the **UP** or **DOWN** touch pad switch on the dryer controller to change the cool down time. Once either the **UP** or **DOWN** touch pad switch is pressed, the temperature L.E.D. and the cool down time on the 4-digit numeric display will flash. If you press and hold down either the **UP** or **DOWN** touch pad switch, you will increment (**UP** arrow) or decrement (**DOWN** arrow) through the cool down times available (2 through 60 minutes if the controller has a red dot sticker or 2 through 15 minutes if the controller has no red dot sticker). To not change the cool down time, do not press either the **UP** or **DOWN** touch pad switch. Go to the next step.
  - 9) Press and release the **SELECT/ENTER** touch pad switch on the dryer controller. Once the **SELECT/ENTER** touch pad switch is pressed and released, the cool down L.E.D. will switch off, the dry cycle L.E.D. and the programming L.E.D. will remain on, the reversing L.E.D. will illuminate, and either "rEv" (reversing mode) or "nrEv" (non-reversing mode) will be shown on the 4-digit numeric display.
  - 10) Press and release either the **UP** or **DOWN** touch pad switch to change between reversing and nonreversing operation. Once either the **UP** or **DOWN** touch pad switch is pressed, the reversing L.E.D. and the "rEv" (reversing mode) or the "nrEv" (Non-reversing mode) shown on the 4-digit numeric display will flash. To not change the reversing or non-reversing mode of operation, do not press either the **UP** or **DOWN** touch pad switch. Go to the next step.
  - 11) Press and release the **SELECT/ENTER** touch pad switch on the dryer controller. Once the **SELECT/ENTER** touch pad switch is pressed and released, the programming L.E.D. will switch off, the reversing L.E.D. and the dry cycle L.E.D. will remain on, and the flashing reversing (rEv) or the non-reversing (nrEv) on the 4-digit numeric display will stop flashing and remain.
  - 10) At this point, you have two choices:
    - a) You can perform the modified dry cycle by pressing and releasing the **START** touch pad switch on the dryer controller touch pad. If you start the modified cycle, the total dry time will appear on the 4-digit numeric display and it will count down to 0 as the dry cycle progresses.
    - b) You can clear the modified dry cycle program by pressing and releasing the **STOP** touch pad switch. If you choose to clear the modified dry cycle, the 4-digit numeric display will change to "LOAD".

---

## **TEMPORARY REVERSING DRYER CONTROLLER PROGRAMMING EXAMPLE**

REQUIREMENTS: Dry a load with 40 minutes of actual heat at 185°F and five minutes of cool down.

The following procedure will show you how to temporarily modify the existing dry cycle 5 program for one cycle of drying. It is based on the assumption that the factory defaults have not been permanently changed. If they have been changed, the steps of this procedure will be the same, but the values that are displayed will be different. The amount of times that the **UP** or **DOWN** touch pad switches of the dryer controller must be pressed and released may also be different.

If you want the change to be permanent, go to the "PERMANENT DRYER CONTROLLER PROGRAMMING" section of this manual.

### **PROCEDURE:**

- 1) After the load has been placed in the dryer, press and release the **UP** or **DOWN** touch pad switch on the dryer controller until the L.E.D. for dry cycle 5 is illuminated.
- 2) Press and release the **CYCLE** touch pad switch on the dryer controller. You will see the number "25" on the dryer controller display. The programming L.E.D. and dry time L.E.D. will be illuminated.
- 3) Press and release the **UP** touch pad switch on the dryer controller 17 times so that the display will show a flashing "42". When the **UP** touch pad switch is pressed the first time, the number "26" will be flashing on the dryer controller display. Each number after that will also flash.
- 4) Now, press and release the **SELECT/ENTER** touch pad switch on the dryer controller. The number "42" will stop flashing, the dry time L.E.D. will switch off, the dryer controller display will now show "175", the temperature L.E.D. will illuminate, and the programming L.E.D. and dry cycle 5 L.E.D. will remain on.
- 5) Press and release the **UP** touch pad switch on the dryer controller one time so the controller display will show a flashing "185". Each press of the **UP** touch pad switch will increment the temperature by five degrees.
- 6) Now, press and release the **SELECT/ENTER** touch pad switch on the dryer controller. The number "185" will stop flashing, the temperature L.E.D. will switch off, the dryer controller display will now show a number "2", the cool down L.E.D. will illuminate, and the programming L.E.D. and dry cycle 5 L.E.D. will remain on.
- 7) Press and release the **SELECT/ENTER** touch pad switch on the dryer controller, since the desired cool down time is two minutes. After you press the **SELECT/ENTER** touch pad switch, the cool down L.E.D. will switch off, the dryer controller display will show "nrEv", the reversing L.E.D. will illuminate, and the programming L.E.D. and the cycle 5 L.E.D. will remain on.
- 8) Press and release either the **UP** or **DOWN** touch pad switch on the dryer controller once. A flashing "rEv" will appear on the dryer controller display and the reversing L.E.D. will start to flash. Each press and release of either the **UP** or **DOWN** touch pad switch will toggle between the reversing mode ("rEv") and the non-reversing mode ("nrEv").
- 9) Press and release the **SELECT/ENTER** touch pad switch on the dryer controller. Once the **SELECT/ENTER** touch pad switch is pressed and released, the programming L.E.D. and the reversing L.E.D. will switch off, the dry cycle 5 L.E.D. will remain on, and the flashing "rEv" will stop flashing and remain on.

You are now ready to start the new dry cycle. The new dry cycle will be in effect for one dry cycle only. After the dry cycle is done, or if the **STOP** touch pad switch on the dryer controller is pressed and released twice, consecutively, the cycle 5 program will revert to the factory default settings.

If you press the **START** touch pad switch on the dryer controller, the controller display will change from the "ReV" to the number "42" and dry cycle 5 will begin.

---

## **PERMANENT REVERSING DRYER CONTROLLER PROGRAMMING**

The permanent programming mode will allow the change of the stored dry cycle settings in the dryer controller until the operator physically changes them again. The factory default settings can be restored in the dryer controller by pressing the default settings push-button on the back (component) side of the dryer controller circuit board. It is labeled and located at the lower middle side of the printed circuit board, as you face the component side of the board. It must be pressed and held down for at least three seconds.

To permanently change a dryer controller cycle, follow the procedure below. Things that are displayed on the 4-digit numeric display will be in "quotation marks". Touch pad switches on the dryer controller that physically need to be pressed will be in **CAPITAL AND BOLD LETTERS**.

If, at any time, you want to escape the permanent programming mode while changing the settings, you can press the **STOP** touch pad switch on the dryer controller if the 4-digit numeric display is not flashing. The **SELECT/ENTER** touch pad switch on the dryer controller can be pressed and released to enter the flashing value shown on the 4-digit numeric display and allow you to escape.

### **PROCEDURE**

- 1) Make sure the dryer is not in a dry cycle. The 4-digit numeric display on the dryer controller will show "LOAD" when the dryer is not in a dry cycle.
- 2) Press and release the **PROG** touch pad switch on the dryer controller.
- 3) Press and release the **UP** touch pad switch on the dryer controller. The programming L.E.D. will illuminate and the 4-digit numeric display on the dryer controller will change to "Prog".
- 4) Press and release either the **UP** or **DOWN** touch pad switch to choose the dry cycle you want to change (dry cycle 1 through 5). The dry cycle L.E.D. will illuminate to indicate which dry cycle you are choosing. If you press and hold down either the **UP** or **DOWN** touch pad switch, the controller will sequence through the five dry cycles.
- 5) Press and release the **SELECT/ENTER** touch pad switch once you have chosen the dry cycle you want to change. After you press the **SELECT/ENTER** touch pad switch, the dry time L.E.D. will illuminate, the dry cycle L.E.D. and the programming L.E.D. will remain illuminated, and the total dry time will also be displayed on the 4-digit numeric display.
- 6) Press and release either the **UP** or **DOWN** touch pad switch on the dryer controller to change the total dry time. Once either **UP** or **DOWN** touch pad switch is pressed, the dry time L.E.D. and the total dry time on the 4-digit numeric display will flash. If you press and hold down either the **UP** or **DOWN** touch pad switch, you will increment (**UP** arrow) or decrement (**DOWN** arrow) through the total dry times available (1 through 60 minutes). The dry time on the controller display includes the cool down time along with the heated time. To not change the total dry time, do not press either the **UP** or **DOWN** touch pad switch. Go to the next step.
- 7) Press and release the **SELECT/ENTER** touch pad switch of the dryer controller. Once the **SELECT/ENTER** touch pad switch is pressed and released, the dry time L.E.D. will switch off, the dry cycle L.E.D. and programming L.E.D. will remain on, the temperature L.E.D. will illuminate, and the drying temperature will be shown on the 4-digit numeric display.

- 
- 8) Press and release either the **UP** or **DOWN** touch pad switch of the dryer controller to change the drying temperature. Each press and release of either the **UP** or **DOWN** touch pad switch will either increase or decrease, respectively, the temperature by five degrees Fahrenheit or three degrees Celsius, depending on how your dryer controller is set up. Once either the **UP** or **DOWN** touch pad switch is pressed, the temperature L.E.D. and the drying temperature on the 4-digit numeric display will flash. If you press and hold down either the UP or DOWN touch pad switch, you will increment (**UP** arrow) or decrement (**DOWN** arrow) your way through the available drying temperatures (105° Fahrenheit or 41° Celsius, up to 195° Fahrenheit or 90° Celsius). If you do not want to change the drying temperature, do not press either the **UP** or **DOWN** touch pad switch. Go to the next step.
  - 9) Press and release the **SELECT/ENTER** touch pad switch on the dryer controller. Once the **SELECT/ENTER** touch pad switch is pressed and released, the temperature L.E.D. will switch off, the dry cycle L.E.D. and programming L.E.D. will remain on, the cool down L.E.D. will illuminate, and the cool down time will be shown on the 4-digit numeric display.
  - 10) Press and release either the **UP** or **DOWN** touch pad switch on the dryer controller to change the cool down time. Once either the **UP** or **DOWN** touch pad switch is pressed, the cool down L.E.D. and the cool down time on the 4-digit numeric display will flash. If you press and hold down either the **UP** or **DOWN** touch pad switch, you will increment (**UP** arrow) or decrement (**DOWN** arrow) through the cool down times available (2 through 60 minutes if the controller has a red dot sticker or 2 through 15 minutes if the controller has no red dot sticker). To not change the cool down time, do not press either the **UP** or **DOWN** touch pad switch. Go to the next step.
  - 11) Press and release the **SELECT/ENTER** touch pad switch on the dryer controller. Once the **SELECT/ENTER** touch pad switch is pressed and released, the cool down L.E.D. will switch off, the dry cycle L.E.D. and programming L.E.D. will remain on, the reversing L.E.D. will illuminate, and either "rEv" (reversing mode) or "nrEv" (non-reversing mode) will be shown on the 4-digit numeric display.
  - 12) Press and release either the **UP** or **DOWN** touch pad switch on the dryer controller to change between reversing and non-reversing operation. Once either of the **UP** or **DOWN** touch pad switch is pressed, the reversing L.E.D. and the "rEv" (reversing mode) or the "nrEv" (non-reversing mode) shown on the 4-digit numeric display will flash. To not change the reversing or non-reversing mode of operation, do not press either the **UP** or **DOWN** touch pad switch. Go to the next step.
  - 13) Press and release the **SELECT/ENTER** touch pad switch on the dryer controller. Once the **SELECT/ENTER** touch pad switch is pressed and released, the cool down L.E.D. will switch off, the dry cycle L.E.D. and programming L.E.D. will remain on, and the 4-digit numeric display will change to "Prog".
  - 12) Press and release the STOP touch pad switch on the dryer controller to save the cycle program and escape the programming mode. If you want to change the same dry cycle program again, press the **SELECT/ENTER** touch pad switch and continue at step 6 of this procedure. If you want to modify another dry cycle program, go to step 4 of this procedure and continue.
  - 13) If you pressed the **STOP** touch pad switch to escape the programming mode, you may now start the dry cycle by pressing the **START** touch pad switch.

---

## **PERMANENT REVERSING DRYER CONTROLLER PROGRAMMING EXAMPLE**

REQUIREMENTS: Dry a load with 50 minutes of actual heat at 195°F and three minutes of cool down.

The following procedure will show you how to permanently modify the existing dry cycle 5 program for one cycle of drying. It is based on the assumption that the factory defaults have not been permanently change. If they have been changed, the steps of this procedure will be the same, but the values that are displayed will be different. The amount of times that either the **UP or DOWN** touch pad switch of the dryer controller must be pressed and released may also be different.

If you want the change to be temporary (for only one dry cycle), go to the "TEMPORARY REVERSING DRYER CONTROLLER PROGRAMMING" section of this manual.

### **PROCEDURE:**

- 1) After the load has been placed in the dryer, press and release either the **UP** or **DOWN** touch pad switch on the dryer controller until the L.E.D. for dry cycle 5 is illuminated.
- 2) Press and release the **PROG** touch pad switch on the dryer controller. The display of the dryer controller will not change.
- 3) Immediately, press and release the **UP** touch pad switch on the dryer controller. The controller display will change from "LOAD" to "Prog". You have now entered the permanent programming mode. The dry time L.E.D. will remain on and the programming L.E.D. will illuminate.
- 4) Press and release the **SELECT/ENTER** touch pad switch once. The dry time 5 L.E.D. and programming L.E.D. will remain on, the dry time L.E.D. will illuminate, and the dryer controller will show the number "25".
- 5) Press the **UP** touch pad switch 28 times until the display of the dryer controller shows the number "53".
- 6) Press and release the **SELECT/ENTER** touch pad switch of the dryer controller once. The dry cycle 5 L.E.D. and programming L.E.D. will remain on, the dry time L.E.D. will switch off, the temperature L.E.D. will illuminate, and the dryer controller display will show the number "175".
- 7) Press and release the **UP** touch pad switch four times until the dryer controller display shows the number "195".
- 8) Press and release the **SELECT/ENTER** touch pad switch of the dryer controller. The dry cycle 5 L.E.D. and the programming L.E.D. will remain on, the temperature L.E.D. will switch off, the cool down L.E.D. will illuminate, and the dryer controller display will show the number "5".
- 9) Press and release the **UP** touch pad switch once until the dryer controller display shows the number "3".
- 10) Press and release the **SELECT/ENTER** touch pad switch of the dryer controller. The dry cycle 5 L.E.D. and the programming L.E.D. will remain on, the cool down L.E.D. will switch off, the reversing L.E.D. will illuminate, and the dryer controller display will show "nrEv".
- 11) Press and release either the **UP** or **DOWN** touch pad switch on the dryer controller once. A flashing "rEv" will appear on the dryer controller display and the reversing L.E.D. will start to flash. Each press and release of either the **UP** or **DOWN** touch pad switch will toggle between the reversing mode ("rEv") and the non-reversing mode ("nrEv")

- 12) Press and release the **SELECT/ENTER** touch pad switch of the dryer controller. Once the **SELECT/ENTER** touch pad switch is pressed and released, the reversing L.E.D. will switch off, the programming L.E.D. and the dry cycle 5 L.E.D. will remain on, and the flashing "rEv" will be replaced by the word "Prog".
- 13) Press and release the **STOP** touch pad switch of the dryer controller. The dry cycle 5 L.E.D. will remain on, the programming L.E.D. will switch off, and the dryer controller display will change to the word "LOAD".

The dryer is now ready for the new modified dry cycle to start. This modified dry cycle 5 program will remain in the dryer controller memory until the default settings push button is pressed. This default setting push button is located on the component side of the dryer controller printed circuit board at the lower middle side.

## REVERSING OPTIONS

The dryer can be set to reverse at different intervals dependent on owner's preference. The style of operation is determined by the location of the BROWN jumper wire located in the rear control box, on the frequency drive. (See image for jumper location)

any wires on VFD.

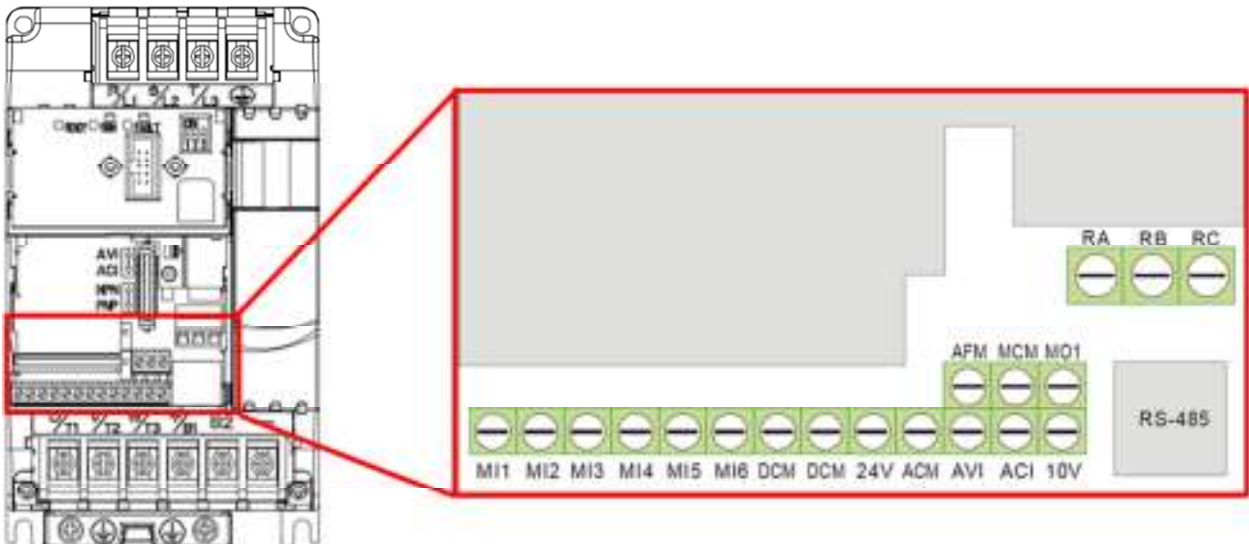

Style	Dryer Operation	FWD (sec)	REV (sec)	Jumper Locations	
				Pos (1)	Pos (2)
1	NON-REV.	YES	NO	DCM	MCM
2	REV.	30	30	DCM	MI2
3	REV.	60	60	DCM	MI4
4	REV.	90	90	DCM	MI5
5	REV.	120	120	DCM	MI6

### 2.11.5 MAXIMUM SPIN SPEED ADJUSTMENT (All washers except T-950)

If desired, the washer can be adjusted to limit the maximum extract spin speed for all wash cycles.

To make this adjustment, a jumper wire must either be installed or removed on the Variable Frequency Drive (VFD), depending on the washer model and desired speed. This Dexter jumper part number 8220-057-036 (qty 1) is factory supplied on terminal points "10V" and "RC". Remove this jumper to make new jumper connections if necessary. Refer to figure below for the approximate location of the control terminations on the Variable Frequency Drive (VFD) and for appropriate jumper connection points indicated with an "X" for the desired maximum spin speed setting. If no adjustment to the default spin speed is desired, do not remove or add any wires on VFD.

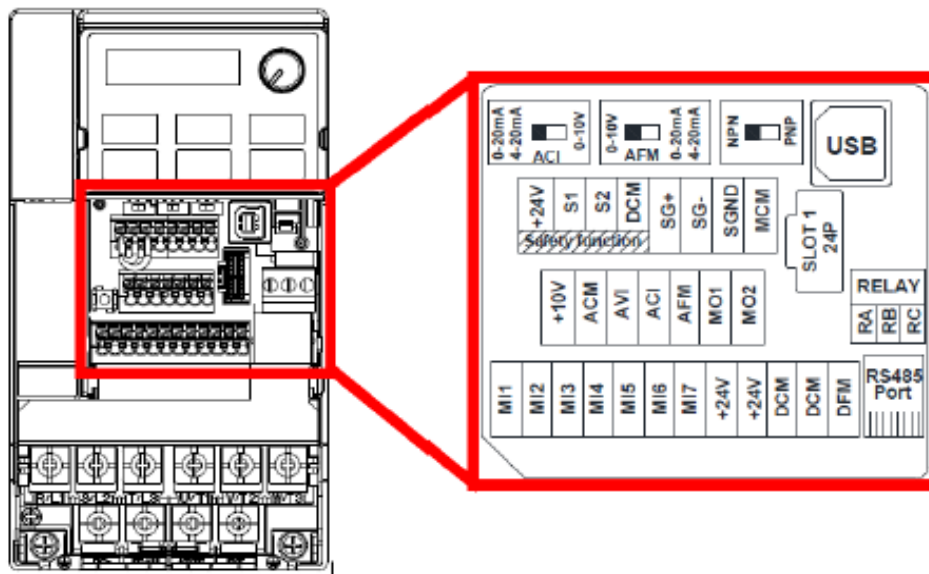

**Control Terminations on Variable Frequency Drive**

V Series Washer Model	Max Spin Speed	Jumper Terminal Locations on Variable Frequency Drive (VFD)													
		MI1	MI2	MI3	MI4	MI5	MI6	DCM (Left)	DCM (Right)	24V	ACM	AVI	ACI	10V	MO1
T-300, T-400,	60 G												X		X
T-600, T-900,	80 G				X			X							
T-1200	100 G	Default Setting (No Jumper Required)													
T-350, T-450, T-750	60 G												X		X
	100 G				X			X							
	140 G					X		X							
	200 G	Default Setting (No Jumper Required)													
T-650, T-1450	100 G												X		X
	140 G	REMOVE Brown Jumper Between MI5/MO1													
	200 G	Default Setting (No Jumper Required)													

**Spin Speed Adjustment Jumper Locations**

**MAXIMUM SPIN SPEED ADJUSTMENT (T-950 Only)**

The variable frequency drive allows for varying acceleration during Final Spin on T-950 models. It is important to utilize a decreased acceleration rate when the application power is low. This acceleration rate is determined by a white wire jumper installed on the drive terminal block from +10V to AVI.

Remove the wire jumper when input power is between 208 and 219 volts. Keep the jumper installed when input power is between 220 and 240 volts. Reference the drawing below for the jumper location.

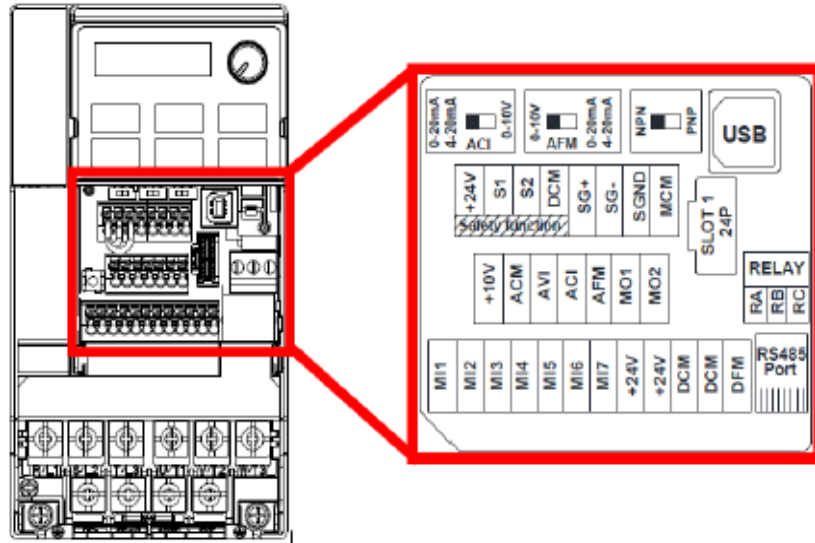

**Control Terminations on Variable Frequency Drive**

V Series Washer Model	Input Voltage	Max Spin Speed	Jumper Terminal Locations on Variable Frequency Drive (VFD)												
			MI1	MI2	MI3	MI4	MI5	MI6	DCM (Left)	DCM (Right)	24V	ACM	AVI	ACI	10V
T-950	240V	140 G	REMOVE Brown Jumper Between MI5/M01												
		200G											X		X
	208V	140 G	REMOVE Brown Jumper Between MI5/M01												
		200G	No Jumper required												

**T-950 Spin Speed Adjustment Jumper Locations**





---

# **Section: 4**

Dryer Service,  
Trouble Shooting  
and Schematics

---

# Service Procedures

## Clothes Door Removal

1. The clothes door may be removed from the hinge bracket by unscrewing and removing the allen-head pivot screw located at the door upper hinge point.
2. Next lean the door out of the top of the hinge bracket and lift the door from the bottom hinge pin.

**NOTE:** the spacer between the bottom of the door and the hinge.

## Clothes Door Latch Adjustment

1. Loosen the lock nut on the latching stud. It is located directly behind the door handle.
2. Open the loading door.
3. Screw the door catch stud in or out as necessary and then retighten the lock nut.

## Door Switch Removal And Installation

1. Each door switch is located directly behind the hinge plate of the loading door assembly.
2. The entire switch can now be pulled from the front panel opening.
3. The switch has two clips that hold it in place on the rear of the switch.
4. With the panel removed, you can now squeeze the two clips and allow switch to be pushed back through panel and grasped from the front and switch removed.

## Installation Of Clothes Door Window And Gasket

1. Place the clothes door, with its face down, on a solid surface.

**NOTE:** Prewarming the gasket makes the installation much easier.

2. Install the window gasket on the clothes door flange. The wider lip of the gasket should be on the bottom side or front face of the clothes door and the ridges should be up.
3. Locate the seam at the latching stud.
4. Apply a soapy water solution or rubber lubricant to the gasket.
5. Slide the glass into the middle of the door ring and gasket with half of the glass above the door and half below.
6. While pressing down on the glass, stand the door up and use a modified screw driver with the end rounded off to install half of the glass. Lay the door down and install the other half.
7. At the six o'clock position, pry the glass up enough to install the black spacer. (Reuse from old door gasket)

## High Limit Thermostat Locations And Functions

**A. Burner Housing-** This hi-limit is located on the back side of each burner housing.

1. The thermostat opens the circuit to the main burners in the event of malfunction in the gas control area or temperature control. This thermostat will open quickly if there is a significant loss of air flow over the burner area.
2. It is covered by a guard and is held in place by two screws. There are spacers between the thermostat and bracket which must be used to give proper operation.

---

**B. Manual Reset Over temperature Safety Thermostats-** The second hi-limit thermostat is located on the right side of each burner housing as you view from the back of the machine. It is just above the gas valve and covered by a guard with a small access hole.

1. The manually resettable thermostat limits the operating temperature a dryer can reach should some abnormal situation occur.
2. Should one of the thermostats be tripped, that particular tumbler will cease to heat until the thermostat is reset. Once the dryer cools, the thermostat may be reset by inserting a pencil or stick through the opening in the thermostat cover.

**REMOVAL:** To remove either the hi-limit thermostat on the rear of the burner housing or the over-temperature thermostat on the right side of the burner housing, remove the mounting screws holding its respective guard. Next, remove the terminal of each wires attached to the thermostat. Lastly, remove the mounting screws holding the thermostat to the burner.

## Pressure Regulator Adjustment

Use the following procedure whenever it is necessary to check the pressure regulator setting.

**NOTE:** Any adjustment of the pressure regulator must be made with a manometer attached at the plug in the main burner manifold.

1. Shut off the gas supply to the dryer.
2. Remove the 1/8" pipe plug from the end of the main burner manifold.
3. Attach a manometer to the manifold end.
4. Remove the pressure regulator cover screw on the gas valve.
5. Open the shutoff valve, and operate the dryer.
6. Adjust the pressure for a manometer reading of 3.5" water column gas pressure. (11.0" for L.P.)

**NOTE:** The main burners must be operating when adjusting the pressure regulator.

7. Shut off the gas supply to the dryer. Remove the manometer and install the 1/8" pipe plug in the manifold.
8. Open the shut off valve, start the dryer and check for gas leaks while the burners are ignited.

## Heat Sensor

This unit takes the place of the regulating thermostat on a mechanical timer dryer. The Heat Sensor is a thermistor. The way these work is fairly simple. As the temperature goes up, the resistance in the thermistor (heat sensor) goes down. As the temperature drops, the resistance in the thermistor (heat sensor) goes up.

## Electronic Control Removal

Unlock the retaining lock in the control assembly. Slide the control out of the machine holding the control by the metal tray. There is enough wire length to allow removing the control tray from the machine before disconnecting the wires.

## Membrane Switch Replacement

The control buttons are an adhesive membrane switch assembly which may be replaced separately. Slide the control out to gain access to disconnect the ribbon connector. The ribbon connector must be pushed solidly and squarely into its connector when connecting a new membrane switch.

## Temperature Sensor Testing

If either tumbler display shows an F1 or F2, that is an indication of possible temperature sensor problems for that tumbler. Before replacing a sensor, check the wires and connections of the sensor for damage. The sensor lead wires are very small and care should be used in routing and connecting them. The sensors are located under the tumblers and may be viewed by removing the lint screen. The temperature sensor should have 10,000 ohms resistance at room temperature if okay.

---

## Temperature Testing

To check the temperature in the dryer tumbler, press and hold the upper or lower start button for the tumbler being checked and while holding the start button also press the temperature button for the temperature to be checked. The display will read out the current temperature.

## 50Lb SWD Temperature Sensor Removal

First remove Electronic Control. Once the Control is removed, disconnect Temp Sensor wires by removing the two gray wire nuts. Remove the two temp sensor mounting screws, 5/16 head, remove Temp Sensor bracket assy. Remove sensor from bracket and replace and reinstall in reverse operation.

## 50Lb SWD Upper Front Panel Removal

The loading door does not have to be removed to remove the front panels on this model.

1. Remove the left two screws with finish washers.
2. Remove the right two screws with finish washers, at this time the front panel is loose but connected by the harness to the door switch.

**NOTE:** Always remove power from the machine before changing drive belts or working with the drive system.

## Final Drive Belt Replacement

To replace the final drive belt turn the cylinder slowly by hand and work the belt off of the large pulley.

## Motor Drive Belt Replacement

To replace the motor drive belt the final drive belt should be removed as above. Cut the old motor belt and remove. The new motor drive belt fits inside of three of the four motor mounting bolts. To achieve this, remove these three bolts one at a time and slide the belt in past each in turn. In this way the motor is always supported by 3 bolts at any time.

**NOTE:** All drive belts are self adjusting.

## Tumbler Pulley Removal And Installation

Remove the 1 1/2" nut and lock washer. Pull the pulley off the shaft. Upon installation, the tumbler nut should be torqued to 150 ft./lbs.

---

## Inverter Drive Motor removal

Remove power from the machine by turning off the circuit breaker.

Remove Rear Control box cover by removing the one 5/16 screw.

Remove rear belt guards.

Disconnect Motor wires, T1, T2, and T3 from the inverter drive, and the ground screw from the control box.

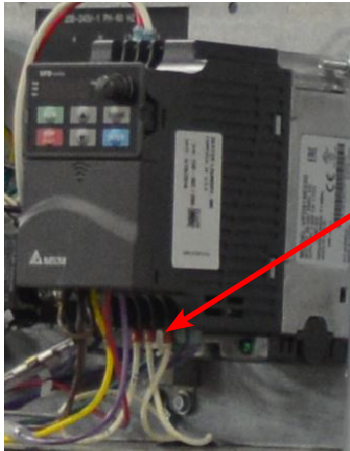

MOTOR WIRES T1, T2, T3,

Remove Tumbler pulley belt to release tension on the motor tension chain and motor.

Remove motor tension spring and chain.

Loosen the three the Motor rod collar set screws (5/32 Allen).

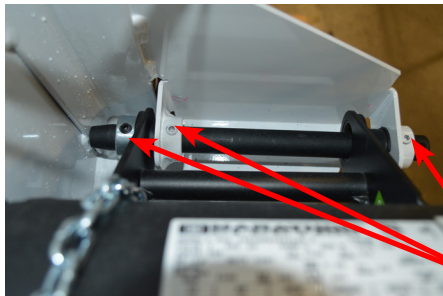

5/32 ALLEN

Remove Motor rod and Motor.

Reassemble in reverse order.

## Motor Blower Assembly Removal And Installation

1. Remove Belts
2. Disconnect Motor harness connector.
3. Remove Tumbler pulley. Remove  $\frac{3}{4}$ " bolt, Next remove pulley using "T" bar puller (needed two  $\frac{3}{8}$ "-16 UNC bolts).
4. Remove Blower back plate (Motor attached). Remove 1 5/16" harness clamp bolt, then remove nine  $\frac{3}{8}$ " nuts and then tilt blower fan to remove.
5. Blower fan is held in place with 2 square headed set screws. Upon reassembly, one blower set screw should fit in the counter sink and the other should mount on the flat side of the shaft. Use red loctite

1. On the set screws and torque to 165 in/lbs.
2. The Motor is mounted with 4 bolts to the motor mounting bracket on the rear of the dryer.
3. Reassemble in reverse order.

## Air Flow Switch Operation And Adjustment

The air flow switch assembly is part of the ignition safety circuit and insures that the burners don't operate unless there is air flow. When the drive motor and blower are running the flat actuator is pulled in against the back of the dryer closing the switch. If this doesn't happen ignition will not occur. The air flow switch assembly is mounted by two screws through the bracket. It can be adjusted by loosening these mounting screws and moving the switch forward or backward.



## Ignition Transformer Fuse

The 1 1/2 amp fuse protects the ignition transformer. To remove it just twist and pull it out.

## Electronic Ignition Module

This machine uses an electronic spark ignition system to directly light the burners in the tumbler.

1. The electronic ignition module for the tumbler is located inside the electrical box. This is the metal box on the back of the tumbler area directly to the left of the final drive pulleys.
2. The red wire from the transformer traveling thru the 1.5 amp fuse and into the module supplies the 24VAC required to operate the entire direct ignition system.
3. The black colored hi-voltage wire (spark plug type) plugs onto the post connector on the module, and the multi-wire plug fits into the side of the module.

## Spark Ignition Module Removal

If the ignition modules are mounted on a bracket, see section A. Otherwise, see section B.

### A: With mounting bracket

Remove the connector housing of the wiring harness attached to the ignition module. Then, remove the terminal of the hi-voltage cable attached to the ignition module. Next, remove the mounting screws holding the ignition module mounting bracket in the rear control box. Lastly, remove the nuts holding the ignition module on its mounting bracket.

### B: Without mounting bracket

Remove all of the terminals of the wiring harness attached to the ignition module. Then, remove the terminal of the hi-voltage cable attached to the ignition module. Lastly, remove the mounting screws holding the ignition module in the control box. If there is no spark or intermittent spark, check black hi-voltage lead wire for damage

**NOTE:** Proper grounding of the ignition system (yellow wires) is very critical for proper ignition sequence.

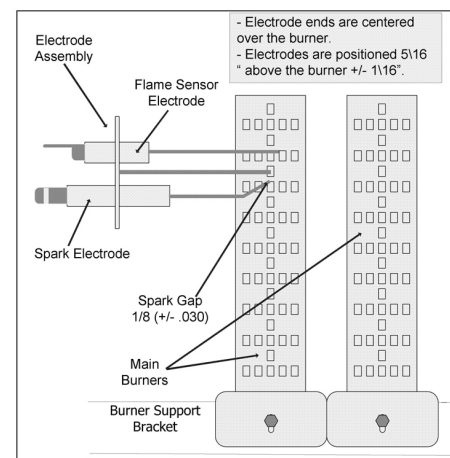

---

## Ignition System-Function & Sequence

During normal dryer operation, the following occurs:

1. The dryer electronic control calls for heat.
2. If the drive motor is running, the motor safety circuit provides power to the electronic control. If the control senses that the heat should be on, a circuit is closed allowing power through the high limit thermostat and air flow switch to the ignition transformer. The transformer provides 24VAC to the ignition module and sparking occurs at the ignition electrode. At the same time 24VAC is applied to the gas valve.
3. Once the flame is established, the sensing electrode detects the presence of flame and the sparking stops.
4. If for any reason the flame is not established in a period of 10 seconds, the electronic control will try this sequence for 3 tries. Normally the 10 seconds "Trial For Ignition" period is ample to establish and prove flame.
5. If the flame is shutdown or blown out during operation, the ignitor will immediately go into "Trial For Ignition" again for 10 seconds.
6. However at the end of 3 separate retries of 10 seconds "Trial for Ignition", the flame is not established, the ignition system goes into "Safety Lock-Out" and will not reactivate the "Trial for Ignition" until there is a current interruption for a period of 15 seconds. This interruption can be provided by opening the dryer loading door and allowing the machine to come to a complete stop for 15 seconds.

## Ignition System-Checkout

1. If flame is present during "Trial For Ignition" period but the system shuts down, there may be an improper ground. The entire ignition system is grounded together including the electrode assembly, the electrode mounting bracket, the burners and the burner bracket. Shutdown can also occur if for some reason the system isn't sensing the flame. Check the sensor for damage and check the connections of the sensor lead.
2. If there is no spark or intermittent spark, check black hi-voltage lead wire for damage or cracks in insulation. (This lead wire must not be taped or connected to any metal edges along its length to prevent pinching and arcing. Also, do not bundle this wire with other wires.)

**NOTE:** Spark gap and electrode location are important. If the electrode is damaged or mounting is changed the spark gap may not be correct for ignition to occur. Check for cracks in the ceramic insulator. Replace electrode assembly if necessary. Also check for carbon or foreign material on the electrodes and clean if necessary.

## Spark Electrode Assembly-Removal

1. Remove electrode cover and disconnect wires to electrodes.
2. Remove two screws to detach electrode assembly.

## Gas Valve Removal (shut off manual gas valve to stop gas flow before removing gas control valve)

1. Disconnect union at gas valve and disconnect wires from gas valve operator coils.
2. Remove right manifold mounting bracket screws and slide manifold to remove from left bracket.

---

## Main Burner Orifice Removal

1. Remove manifold and gas valve assembly as above.
2. Using an open end wrench, remove orifices from manifold.

## Main Burner Removal

1. Remove the 4 screws securing the cover for the burner housing and the one screw mounting the high limit cover. With the burner housing cover removed, there is complete access to the burner assemblies.

## Recirculation Chamber Inspection

1. Remove Resettable manual overtemp sensor and remove inspection plate in burner chamber between main burners and rear back panel of dryer.

## Cylinder Removal

1. Remove the front panel in front of the cylinder.
2. Remove drive belt, pulley.
3. Pull the cylinder from the front of the machine.

## Adjustment Of Cylinder Assembly With Front Panel Removed

1. Loosen the two top adjusting bolts and two bottom adjusting nuts and lock nuts holding the bearing housing to the drive plate.
2. Loosen the four mounting bolts on the side channels.
3. Open the clothes door and insert a 1/4" thick shim at the 3 and 9 o'clock positions and a 1/8" thick shim at the 6 o'clock position.
4. Tighten the two bottom adjusting nuts and tighten locking nuts.
5. Tighten the bottom right mounting bolt, then the top left mounting bolt. Tighten the remaining two bolts. (Shim where and if necessary.)
6. Tighten the two top adjusting bolts.
7. Remove all the shims from between the front panel flange and cylinder (3, 6, and 9 o'clock).
8. Spin the cylinder to check for rubbing baffles, pressing down hard while rotating. If rubbing is detected, repeat procedure paying particular attention to placement of shims between bearing housing and side channels.

## Tumbler Through Bolt Access Cover

Remove 4 screws that mount the air flow switch to the back of the dryer. Remove 2 screws that retain access cover. With access cover removed, tightness on the tumbler through bolts can be checked and tumbler alignment can be adjusted.

## Bearing Housing Removal

After removing cylinder as previously outlined, simply unbolt the bearing housing and remove.

---

# **Section: 5**

## Troubleshooting & Wiring Schematics

## OPL REVERSING DRYER FAULT CODES

<b>FAULT #</b>	<b>FAULT DESCRIPTION</b>	<b>ACTION</b>
F1	Short in thermostat sensor circuit	Dryer stops and "F1" flashes on the 4-digit display. When short circuit on sensor input is removed, "LOAd" appears on the 4-digit display and the remaining dry time is reset.
F2	Open thermostat sensor.	Dryer stops and "F2" flashes on the 4-digit display. When a good sensor is connected to sensor input, "LOAd" appears on the 4-digit display and the remaining dry time is reset.
F3	EEPROM corrupted	Dryer will not start and "F3" appears on the 4-digit display. The power to the dryer must be cycled to reset the controller. Fault should only occur when starting a dry cycle.
F4	Gas valve on fault.	The drying temperature did not increase 1°F. in 5 minutes. "F4" will flash on the display and the dry cycle will finish without calling for heat (energizing gas valve). Opening the door or pressing the STOP touch pad switch will reset the fault and clear the remaining time in the dry cycle.
F5	Temperature fault	The drying temperature is at least 25°F. above the temperature setting. "F5" will flash on the 4-digit display and the dry cycle will finish without calling for heat (energizing the gas valve). The power to the dryer must be cycled to reset the controller.

## Troubleshooting Tips

Symptom	Probable Cause	Suggested Remedy
Tumbler does not turn	Drive belts	Check both drive belts. Replace if failed.
	Drive motor	Check capacitor and motor. Replace if failed
	Door switch	Check door switch contacts and adjustment. Adjust or replace the door switch
	Electronic Control	Is electronic control closing motor relay to power drive motor? Check for motor light on electronic control. If no light change control. If light is on, check voltage and wiring to motor.

## Troubleshooting Tips Continued

Symptom	Probable Cause	Suggested Remedy
Tumbler turns but no spark at burner	Glass fuse	Check small glass control fuse in back of dryer. Replace if failed.
	Temperature Sensor	The temperature sensor should have between 30,000 ohms and 60,000 ohms resistance at room temperature if okay. Replace if not in this range.
	Ignition	Check for 24VAC output from transformer.
	Transformer	Replace if have 120V between black & white and no 24V between red and yellow.
	Over Temperature	Check to see if manually resettable thermostat. Thermostat is kicked out. Reset by pushing red reset button.
	Ignition control	Check for 24VAC coming into the control on the at burner red wire. If voltage, then check for 24VAC out on the brown wire. Also check for spark at the ignitor. If no 24VAC output or no spark to the ignitor, replace ignition control.
	Air Flow Switch	Check air flow switch to be sure it closes when dryer is running. If not, adjust or replace switch.
	Hi-limit	Check for continuity. Should be 0 ohms resistance when cold. If not, replace thermostat.
	Gas supply	No gas can cause system lockout
Electronic Control	Is electronic control closing gas relay to power Control heat circuit? Check for gas light on electronic control. If no light change control. If light is on, check voltage and components in heat circuit at transformer at rear of unit.	

## Troubleshooting Tips Continued

Symptom	Probable Cause	Suggested Remedy
Tumbler turns, ignition sparks, no flame	Gas Supply	Make sure gas supply is working.
	Gas Pressure	Make manometer check of gas pressure. Adjust if necessary.
	Spark Electrode Sensor	Check for damage to electrode or mounting. Replace if necessary.
	Gas Valve	Check coil continuity, replace valve if failed.
	Ignition Control	Check for 24VAC to gas valve coils. If no voltage replace ignition control.
Burner Lights, but goes on and off	Electrodes	Check low voltage harness for possible wire break or cuts to allow no signal back to ignition control
Slow drying	Temperature Setting	Check program for correct high temperature setting. Adjust if necessary.
	Air flow restrictions necessary	<ol style="list-style-type: none"> <li>1. Check lint screen and clean if necessary.</li> <li>2. Check exhaust for correct length and clean if necessary.</li> <li>3. Check exhaust damper to insure that it opens when dryer is running and closes when dryer is not in use.</li> <li>4. Check makeup air to insure that it is adequate. Increase makeup air if necessary.</li> <li>5. Check static Back pressure no more than .3</li> </ol>
	Temperature Sensor	The temperature sensor should have between 30,000 ohms and 60,000 ohms resistance at room temperature if okay. Replace if not in this range.

## Troubleshooting Tips Continued

Symptom	Probable Cause	Suggested Remedy
Erratic display	Initial Start-up	If erratic on initial start-up, leave power on for approximately one hour and check machine operation again.
	Grounding	Machine must be grounded by separate conductor back to neutral bar in breaker box.
	Program	Check program and make corrections if necessary.
	Voltage spike	Power down machine for 20 seconds and repower. If no improvement, replace control.
Manual overtemp Tripping Frequently	Recirculating chamber Lint Accumulation	Remove manual overtemp thermostat and inspect in chamber for excessive lint build up. Access also gained to this chamber by removing recirculation duct mounted at bottom of chamber, or the panel inside burner chamber between burners and rear back panel
	Exhaust ducting Excessive lint buildup	Remove exhaust duct at rear of dryer and inspect for excessive lint build up in complete duct from dryer to where duct exits building.
	Clean lint out of top heat air chamber above tumbler	Remove front panel completely. Be careful of any wiring attached. Remove heated air chamber cover and clean above tumbler back to burner housing.

---

## DNS0050 Reversing 60Hz. Wiring Schematic

### Dryer Idle:

208/240 VAC 60 Hz. power is supplied to the main power terminal block and comes out on BLK/RED and BLK/BLU wire. 208/240 VAC now passes to the motor control relay (R1) and also passes to the multi-tap control step-down transformer. The same 208/240 VAC 60hz line voltage will also be supplied to the voltage inputs of both variable frequency drives. The control circuit will be powered from the 24 VAC secondary side of control step-down transformer. Power out of the transformer will travel through the 2.5A fuse on the black wire for circuit protection. When there is power to the dryer the computer board will be powered and the display lighted from the 24 VAC secondary side of control step down transformer. 24 VAC from here is also on one side of the door switches on a black wire. Closing the upper loading door allows 24 VAC to pass on to the computer board on two blue wires. One blue wire makes 24 VAC available to one side of the motor run relay on computer board. The other blue wire provides a 24 VAC signal to the computer board telling it that the door is closed and door light on the computer board should be illuminated.

### Motor Starting and Running:

The time will display once the "Start" button for upper or lower is pushed and the motor run relay closes on the computer. With this relay closed, 24 VAC passes through to the red wire and is supplied to the motor control relay (R1), and the drive enable relay (R3), and also a violet wire going down to the blower motor centrifugal switch. The upper motor LED on the computer board should be illuminated anytime the computer calls for the upper motor to operate. With the (R1) relay engaged and 208/240 VAC passing through to the blower motor start switch, the incoming power 208/240 VAC is supplied directly to the main run winding and through the start capacitor to the auxiliary winding (start winding). The heat circuit in the dryer cannot operate if the blower motor is not running. As the motor comes up to speed, the centrifugal switch inside motor opens the circuit to the start winding and closes the circuit to allow the 24 VAC on the violet wire to pass to through the centrifugal switch to the other red wire and onto the gas relay on the computer board. At the same time the 24 VAC is sent out on the red wire from the computer board to the drive enable relay (R3). When engaged, this allows the DCM common (yellow wire) signal on the drive to pass through to the brown wire MI1 contact on the variable frequency drive. Completing this circuit engages the drive to send the tumble and reversing voltage to the tumbler motor. From the factory, the motor will tumble one direction for 1 minute and then stop and tumble in the reverse direction for 1 minute. This will continue for the length of the cycle. The time of the reversing action can be modified by moving the brown jumper wire on the factory default DCM to MI4 connection. Placing the jumper from DCM to:

MCM – Non-reversing

MI2 – 30 seconds

MI4 – 60 seconds

MI5 – 90 seconds

MI6 – 120 seconds

---

## Heat Circuit

With the blower motor running, 24 VAC provided through the centrifugal switch on the red wire and connecting to the violet wire to the computer board gas relay. The temperature sensing probe is found under each tumbler in the lint tray area and sends resistance values back to the computer board for temperature sensing. If the computer control senses that the dryer needs heat input, The computer control closes the upper gas relay which passes the incoming 24 VAC from the centrifugal switch back out on the orange wire out of the high limit thermostat. The high limit thermostat is normally closed. (The high limit will open, turning off the heat circuit, if the flame starts moving to the back of the burner housing rather than being pulled into the burner housing due to airflow issues. In this case the high limit will reset on it's own once temperatures are reduced). From the high limit thermostat the 24 VAC travels through to the normally open air flow switch (sail switch) on the brown wire. The air flow switch is pulled closed from the vacuum created when the blower fan is producing airflow. With the dryer running and the air flow switch closed, 24 VAC is supplied to the normally closed upper manual reset over-temp thermostat on the gray wire and then passes to the black wire out of switch and then goes to the terminal block where it connects to a violet wire. The 24 VAC then travels to the RC connection at the variable frequency drive. During tumble mode, this connection closes and the 24 VAC then leaves the variable frequency drive through the RB connection on the red wire to the 1.5 amp in-line fuse that fuses the upper ignition controller (grey box). With 24 VAC now supplied to the upper ignition controller (grey box) it will then send high voltage to the spark ignition electrode via the high voltage lead wire (this lead looks like an automotive spark plug wire) and spark is created. The ignition control module (grey box) simultaneously sends 24 VAC to the gas valve coil on the brown wire which opens the gas valve and allows gas to pass to the main burner. When the gas makes contact with the spark, ignition occurs. Once flame is on the burner tube, the flame sensor will send a signal back to the ignition control on the small black wire that the flame is sensed. At this point, the high voltage sparking stops and the ignition control module (grey box) will allow gas valve coil to remain energized and continue burner operation. If ignition does not occur, the ignition control module (grey box) will spark for 10 seconds before locking out. The control box will attempt 3 times total before a complete lock out in the event of no flame sense.

## Manual Reset Safety Shutoff Over-Temperature Thermostat

The over temperature thermostat is a safety backup for the entire heat circuit and located in the recirculation chamber area on the side of the burner housing. If the dryer over heats this over temperature thermostat opens the circuit to stop voltage from passing to the heat circuit which stops the flame. The computer board continues to count down and the drive motor remains powered and turning so the basket will cool down.

## Cool Down

Near the end of the cycle at the preprogrammed time (2 minutes factory setting - adjustable) the computer board will open the gas relay contact. This happens for the remainder of the cycle. The drive motor will continue to run but without heat. The gas light on the computer board should not be illuminated anytime the computer is in cool down mode. This cool down period allows the clothing (zippers, snaps, etc.) time to cool down to a temperature that is easily handled by customers.

---

## End of Cycle

At the end of the cool down, the computer board opens the upper run relay, which removes power from the blower motor control relay (R1) and also removes power to the (R3) tumble relay which deactivates the variable frequency drive and motor. The motor light on the computer board should no longer be illuminated. The drive motor and tumbler stops and the computer board display now flashes until the dryer loading door is opened. Once the dryer loading door is opened to remove the clothing the display goes back to cycle #.

## Anti-Wrinkle

Anti-Wrinkle is a feature that periodically rotates the dryers after a cycle is complete. If the door was closed at the end of the cycle, and is left closed for 5 minutes, the enunciator will sound and the display begins scrolling "ANTI WRINKLE". 5 seconds later, the dryer motor will turn on for 60 seconds and then turn off. The gas valves will not be activated. The "ANTI WRINKLE" message will continue throughout the time that the motor is turned on. The user can choose to enable or disable this feature. This feature will continue to occur every 5 minutes until the door is opened or 5 anti-wrinkle cycles are exceeded.

# 60Hz Wiring Diagram Dryer

9506-789-001D

WIRING DIAGRAM

DN5050NC-11EB\_R-\_\_\_\_\_X

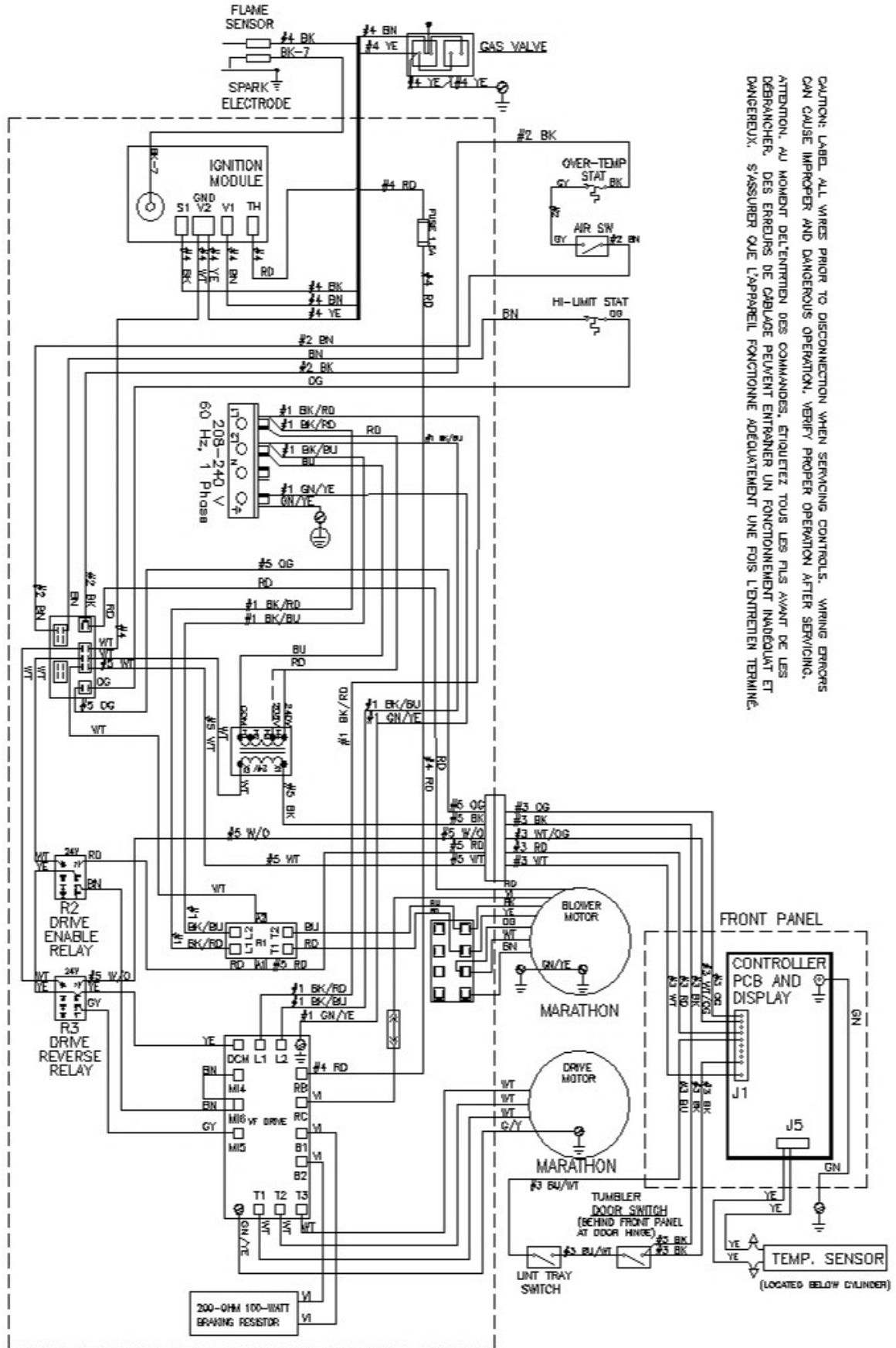

CAUTION: LABEL ALL WIRES PRIOR TO DISCONNECTION WHEN SERVICING CONTROLS. WIRING ERRORS CAN CAUSE IMPROPER AND DANGEROUS OPERATION. VERIFY PROPER OPERATION AFTER SERVICING. ATTENTION: AU MOMENT DE L'ENTRÉE EN COMMANDE, ÉTIQUÉTEZ TOUTS LES FILS AVANT DE LES DÉBRANCHER. DES ERREURS DE CÂBLAGE PEUVENT ENTRAÎNER UN FONCTIONNEMENT INADÉQUAT ET DANGEREUX. S'ASSUREZ QUE L'APPAREIL FONCTIONNE ADÉQUATEMENT UNE FOIS L'EXTREMIÉTÉ TERMINÉE.

# 60Hz Schematic Dryer

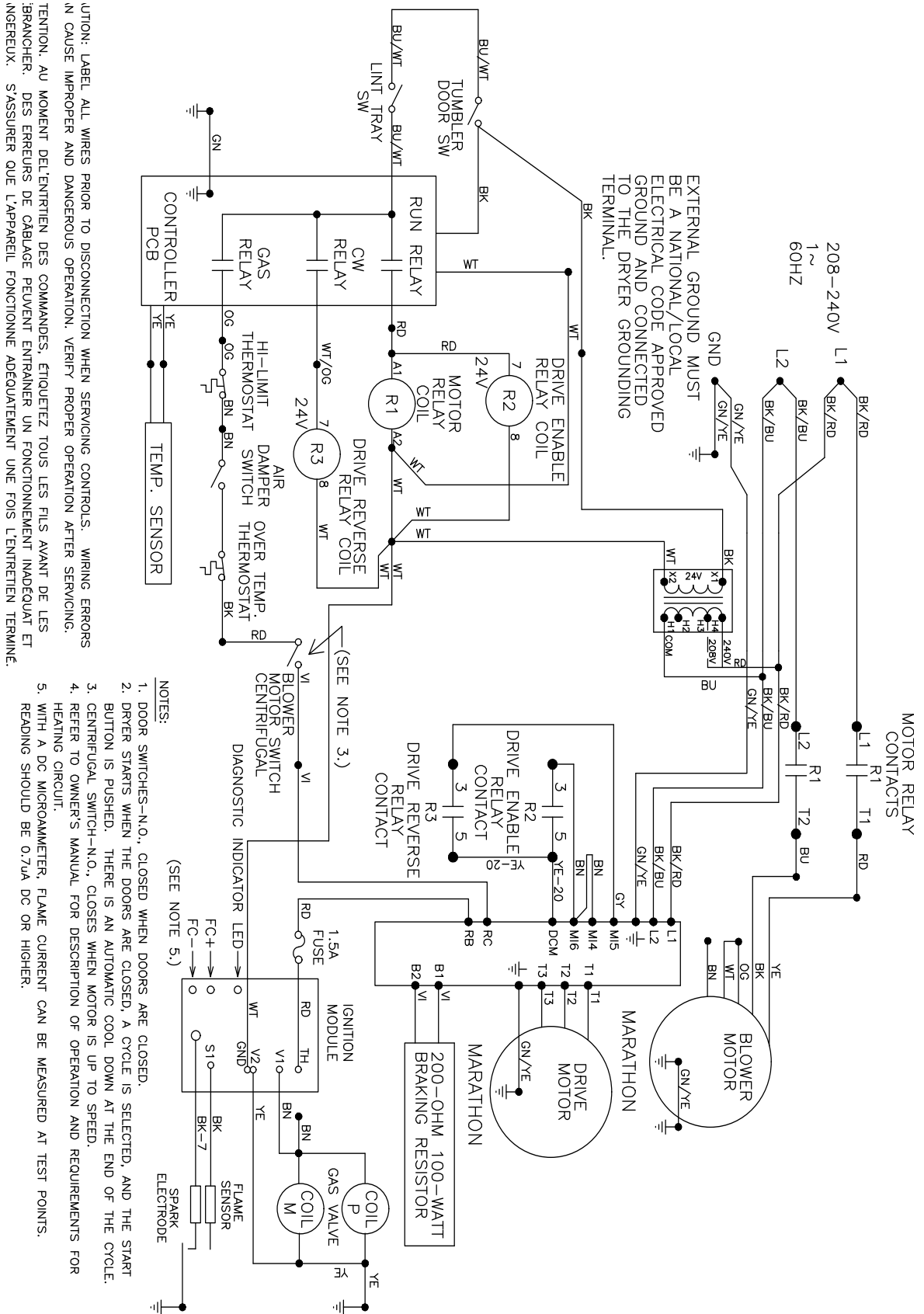

3506-789-001D

SCHEMATIC

DNS050NC-11EB\_R--X





# Section: 6

## Dryer Parts Data

### SWD

## Kits, Assemblies, & Common Parts

Description	Part Number
LINER-BAFFLE,RIGHT(DDBD50 & newer),PTD	9354-013-002
LINER-BAFFLE,LEFT(DDBD50 & newer),PTD	9354-014-002
Kit - Make-Up Air, T-50 SWD	9732-334-001
Kit - 8650-012-004 Lock with spacer	9732-344-002
Emergency Stop Button Kit w/ button and switch ass.	9732-223-002
LP to Natural Conversion Kit for White Rodgers	9732-142-004
Temperature Probe	9501-004-003
Controls Blue	9857-199-002
Controls Black	9857-199-004
Ignition Control Box	9857-182-001
Electrode Assembly	9875-002-003
Hi-Limit Thermostat	9576-203-002
Overtemp Thermostat	9576-207-008
Fuseholder	9200-001-002
Fuse 1.5Amp	8636-018-001
Fuse 2.5Amp	8636-018-004
Relay	5192-299-002
Transformer	8711-013-001
Lint Screen Assembly without Front	9805-033-002
Airflow Switch	9539-461-009
Drive Belt	9040-076-003
Tension Arm Complete Assembly	9861-022-001
Spider/Trunnion	9568-015-001
Door Handle	9244-082-001

# Dryer Cabinet Group

	Description	T-50SWD-11 Reversing	QTY
1	Panel Assy., Front- Upper (SS)	9989-594-001	1
*	Insulation Front Panel, half moon (top)	9277-054-001	1
*	Insulation Front Panel, half moon (bottom)	9277-054-002	1
2	Screw, FLHDCR, 10B x- 1 3/4	9545-008-014	4
3	Washer, Finish, #10	8641-585-001	4
*	Nut, Spring	8640-399-001	4
*	Hinge ,Backup Plate	9982-356-001	1
*	Screw, Countersink, 10-32X 1/2	9545-012-003	1
4	Strap, Hinge (SS/Black)	9544-069-005	2
*	Screw, Hinge to Panel	9545-012-028	8
*	Door Assy., Loading Complete-SS	9960-285-011	1
*	Door Assy., Loading Complete-Chrome/BLK/SS	9960-285-007	1
5	Door Assy., Loading-SS(ring only)	9960-284-002	1
5	Door Assy., Loading-Chrome(ring only)	9960-284-004	1
6	Plate Assy., Hinge (SS)	9982-353-001	1
*	Screw, Hinge to Door	9545-012-015	4
*	Nut, Hinge to Door	8640-413-002	4
*	Cover, Hinge Plate	9074-340-002	1
*	Screw, Phillips-10B x 3/8	9545-008-010	2
7	Glass, Door	9212-002-004	1
8	Gasket, Glass Black	9206-413-002	1
*	Support, Door Glass	9548-117-000	1
*	Tool Install Dryer Door Gasket	8545-064-001	1
9	Gasket, Outer Rim Black	9206-420-005	1
10	Handle, Loading Door	9244-093-001	1
*	Screw, Handle 1/4-20 x 3/8	9545-018-017	2
11	Stud, Door Catch, 7/8	9531-033-003	1
12	Nut, Hex	8640-413-001	1
13	Nut, Acorn	8640-413-003	1
14	Catch, Loading Door	9086-015-002	1
15	Pop Rivet for mtg. catch	8638-190-009	2
16	Screw, Door to Hinge Strap (Special Black Type)	9545-052-001	1
17	Washer, Fiber	8641-436-003	1
*	Cabinet Touch Up Paint (White)	9472-001-013	1

# Cabinet Group

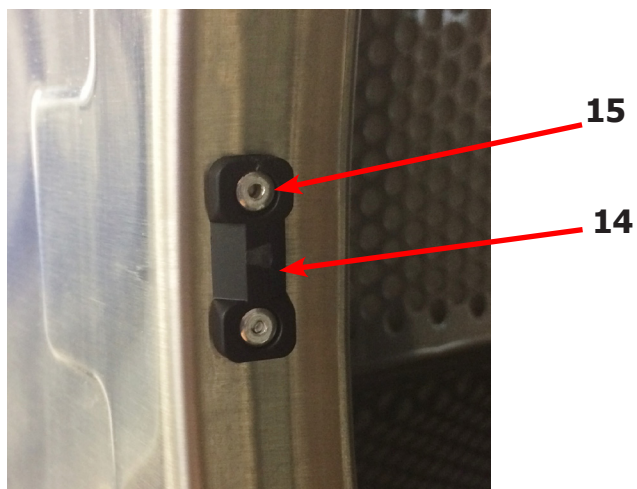
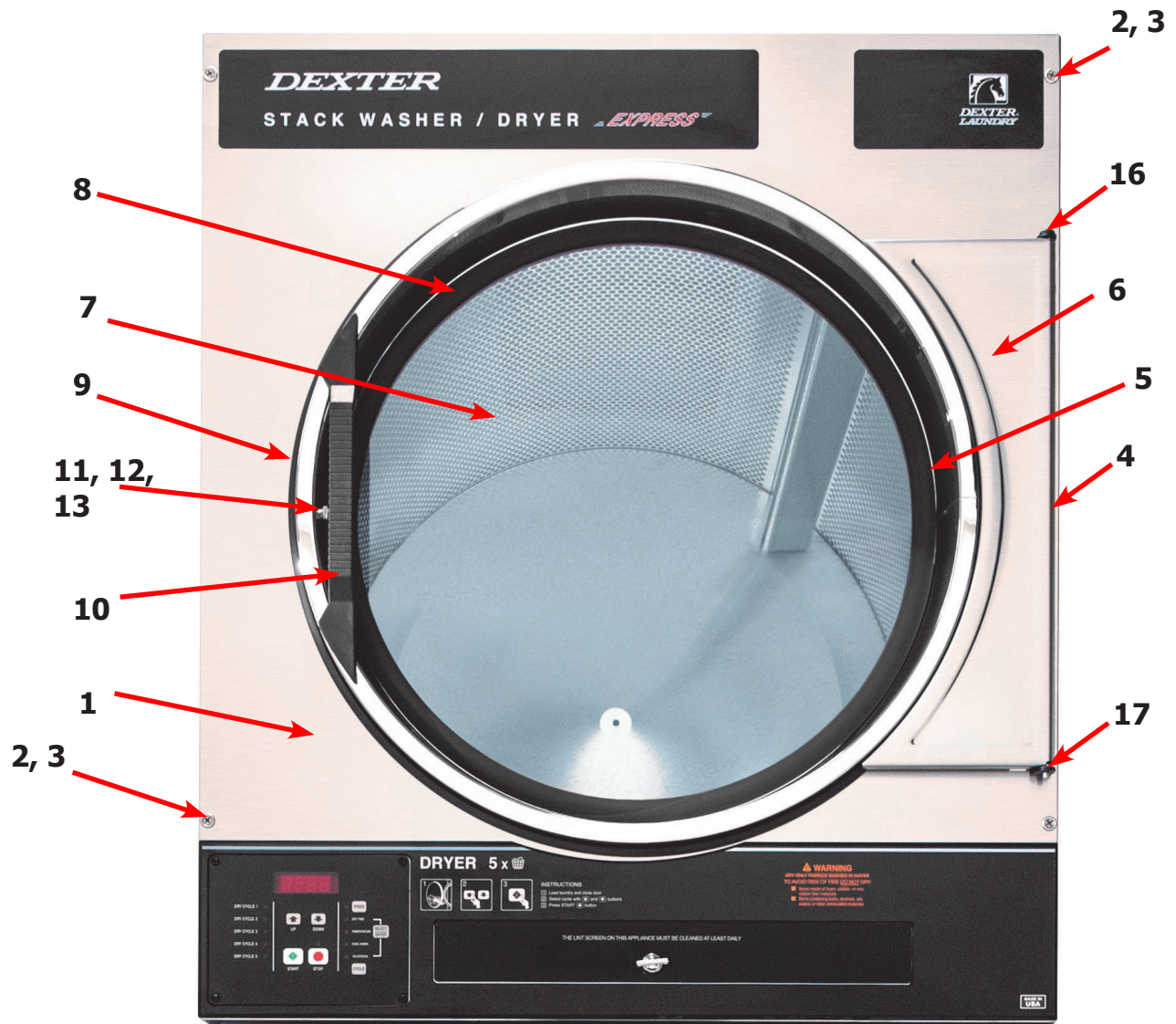

# Dryer Cabinet Group

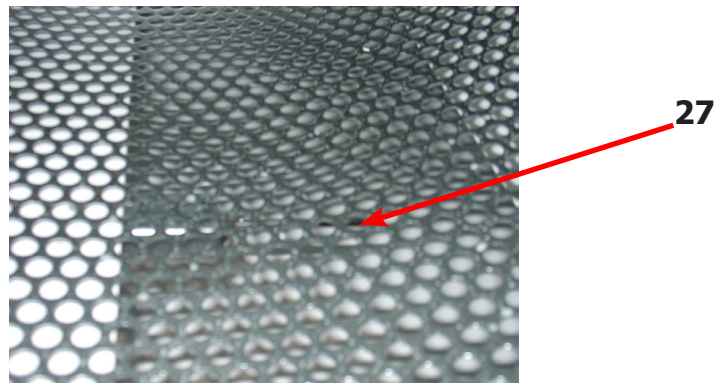
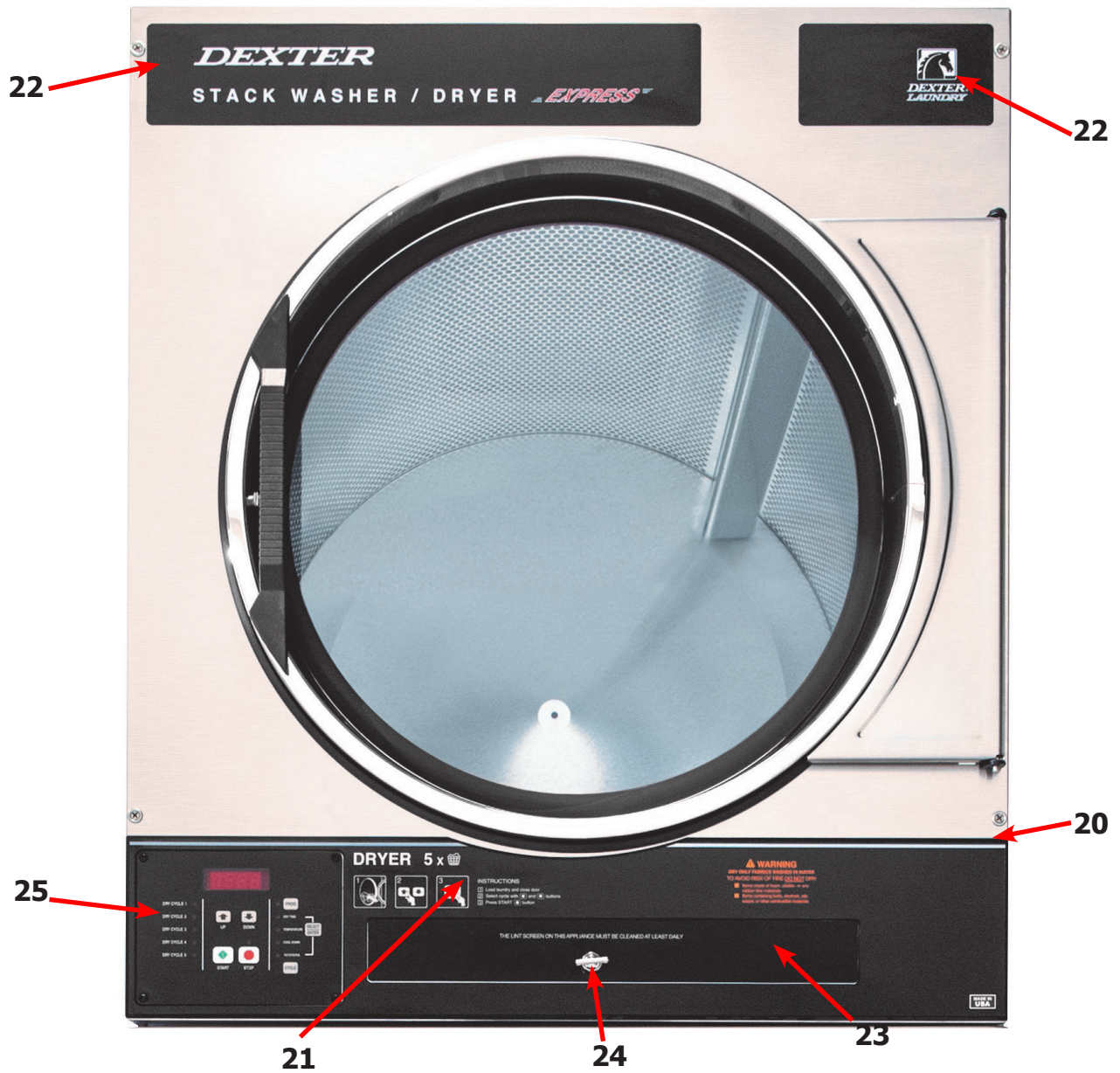

## Cabinet Group Continued

Key	Description	T-50 SWD-11 Reversing	QTY
20	Escutcheon, SWD, Dryer opl	9994-040-001	1
21	Trim, Overlay-Upper Black	9435-054-001	1
*	Screw, #4-40 x 3/16	9545-020-009	12
22	Nameplate Stack Dryer Express Black	9412-202-001	1
*	Lint Drawer Assembly Black	9866-005-005	1
*	Drawer, Front PTD	9974-009-001	1
*	Washer, Flat, #10	8641-581-006	2
*	Washer, Curved-Spring	8641-569-004	2
*	Nut, 10-32	8640-413-007	22
23	Overlay Trim, Lint Drwr-Black	9435-032-001	1
*	Felt Seal (back of lint screen assembly)	9532-143-001	1
*	Lint Screen Assembly ONLY (no front)	9805-039-002	1
*	Replaceable Lint Screen Only	9555-057-008	1
24	Lock-Door Service Thumb Turn	8650-026-002	1
*	Cam, Lock	9095-044-001	1
*	Lint Screen Strap Hold Down Screws 10Bx 1/4	9545-008-001	32
25	Controls Assy, 24VAC, Black	9857-227-002	1
*	Harness, Electronic Control	9627-770-004	1
*	Screw-trhdtrix 6bsd1/2blk	9545-031-009	4
*	Harness, Heat Sensor	9627-679-001	1
*	Wire Nut Connector Grey	8640-276-002	4
27	Sensor Temp/Bracket Control	9501-008-003	2
*	Bracket for Heat Sensor Mounting (Under Basket) w/o sensor	9985-188-001	2
*	Screw, Round Head (Mounts sensor; phillips head)	9545-045-005	2
*	Grommet, 3/16 ID	9209-037-002	2
*	Sensor-Heat Thermistor	9501-004-002	
*	Cover, Cabinet (Top)	9074-371-001	1
*	Insulation Cabinet Cover	9277-041-017	1

## Dryer Modular Cabinet Group 50lb. (After Serial D1.23300.044)

Key	Description	T-50 SWD	QTY
*	Cabinet Base Assembly	9945-170-002	1
*	Back Panel Assembly	9989-740-002	1
*	RH Side Panel Assembly	9989-736-003	1
*	LH Side Panel Assembly	9989-736-004	1
*	RH Lint Rail Guide Assembly	9750-031-001	1
*	LH Lint Rail Guide Assembly	9750-024-001	1
*	Lint Rail Gusset	9210-134-001	1
*	RH Baffle	9049-130-001	1
*	LH Baffle	9049-130-002	1
*	Baffle Reinforcement	9489-062-001	2
*	Heat Chamber Assembly	9870-103-001	1
*	Control Wrapper	9636-253-001	1
*	Angled Baffle Bracket	9029-371-001	2
*	Baffle Support Bracket	9029-374-001	1
*	Upper Cross Brace	9046-108-001	1
*	Cabinet Top Cover	9074-371-001	1
*	10abx3/8 Screw	9545-008-024	3
*	3/16 Blind Rivet	9491-009-001	101
*	Wht 3/16 Blind Rivet	9491-009-005	26

## Door Switch Group

Key	Description	T-50X2-11 Reversing	QTY
1	Door Switches	9539-487-001	2
2	Bracket-Mounting lint tray switch	9029-302-001	1
3	Conduit-Wire	6068-050-001	1

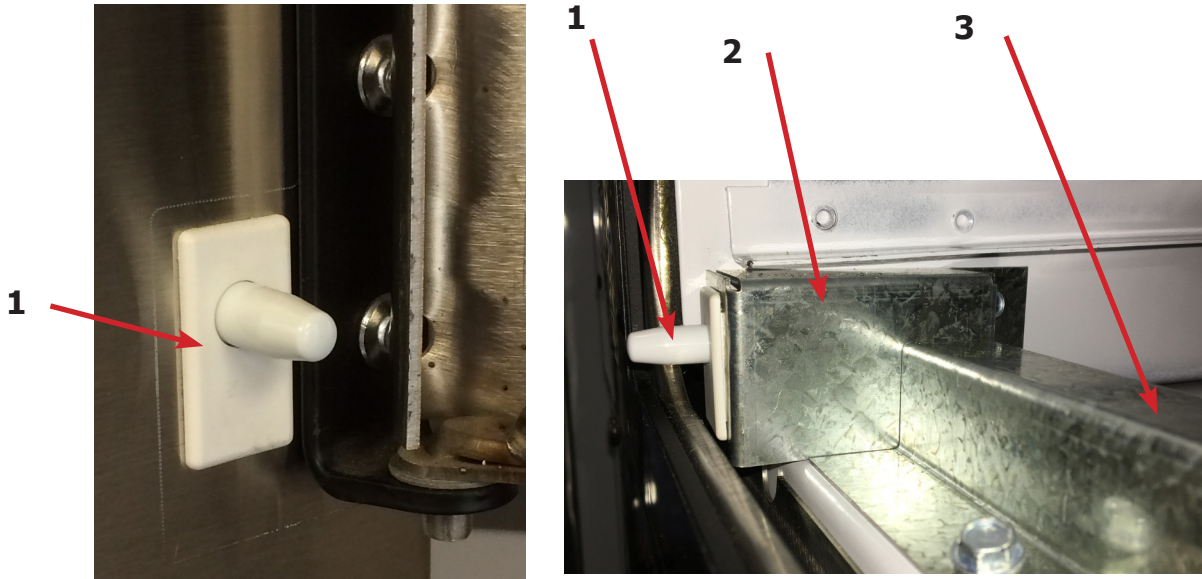

## Hinge Plate Cover

Key	Description	T-50X2-11 Reversing	QTY
1	Cover-Hinge, Black	9074-340-002	1
2	Screw-TRHDCR, 10B x 3/8, Black	9545-008-010	2

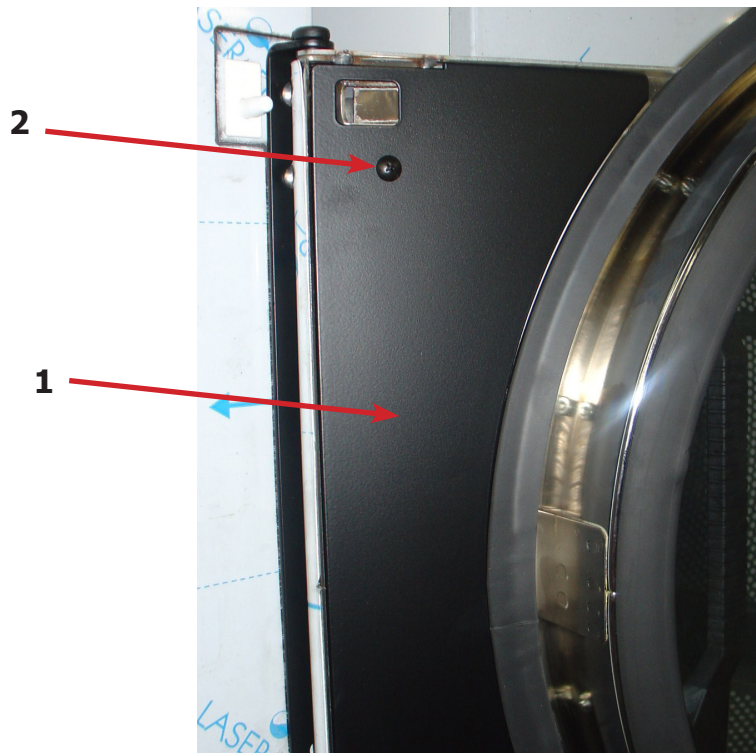

# Sensor Assembly, Thermistor

Key	Description	T-50X2-11 Reversing	QTY
*	Bracket for Heat Sensor Mounting (Under Basket) w/ sensor	9501-008-003	1
1	Bracket Assembly Thermistor	9985-188-001	1
2	Gasket spacer	9206-176-000	1
3	Grommet	9209-037-002	1
4	Screw, 8B x 1/4	9545-045-005	1
5	Sensor-Heat, Thermistor- 50K Ohm	9501-004-002	1
*	Screw-Mounting, 10AB x 3/8	9545-008-024	1

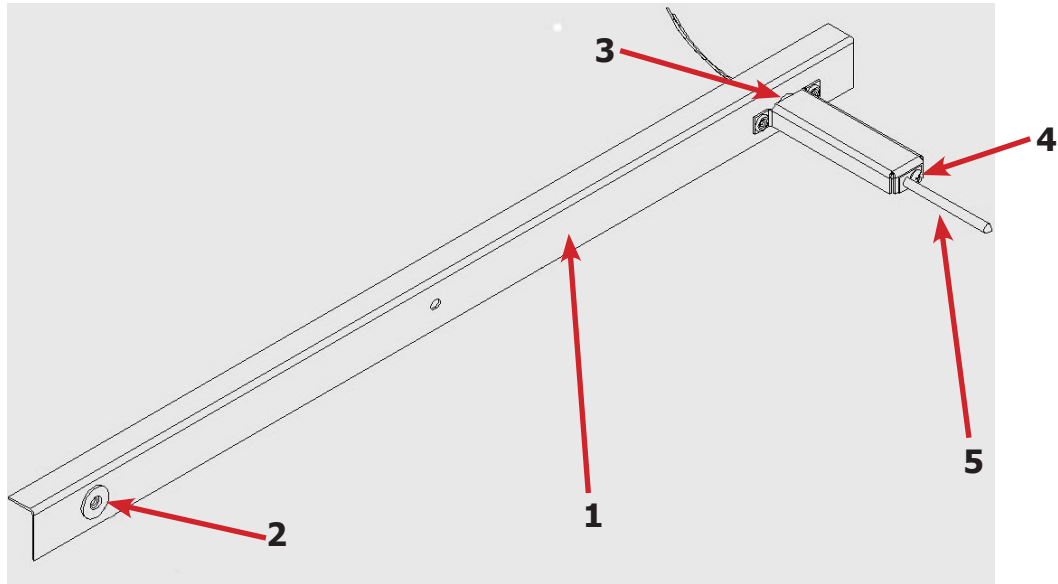

# Dryer Back Panels and Guards

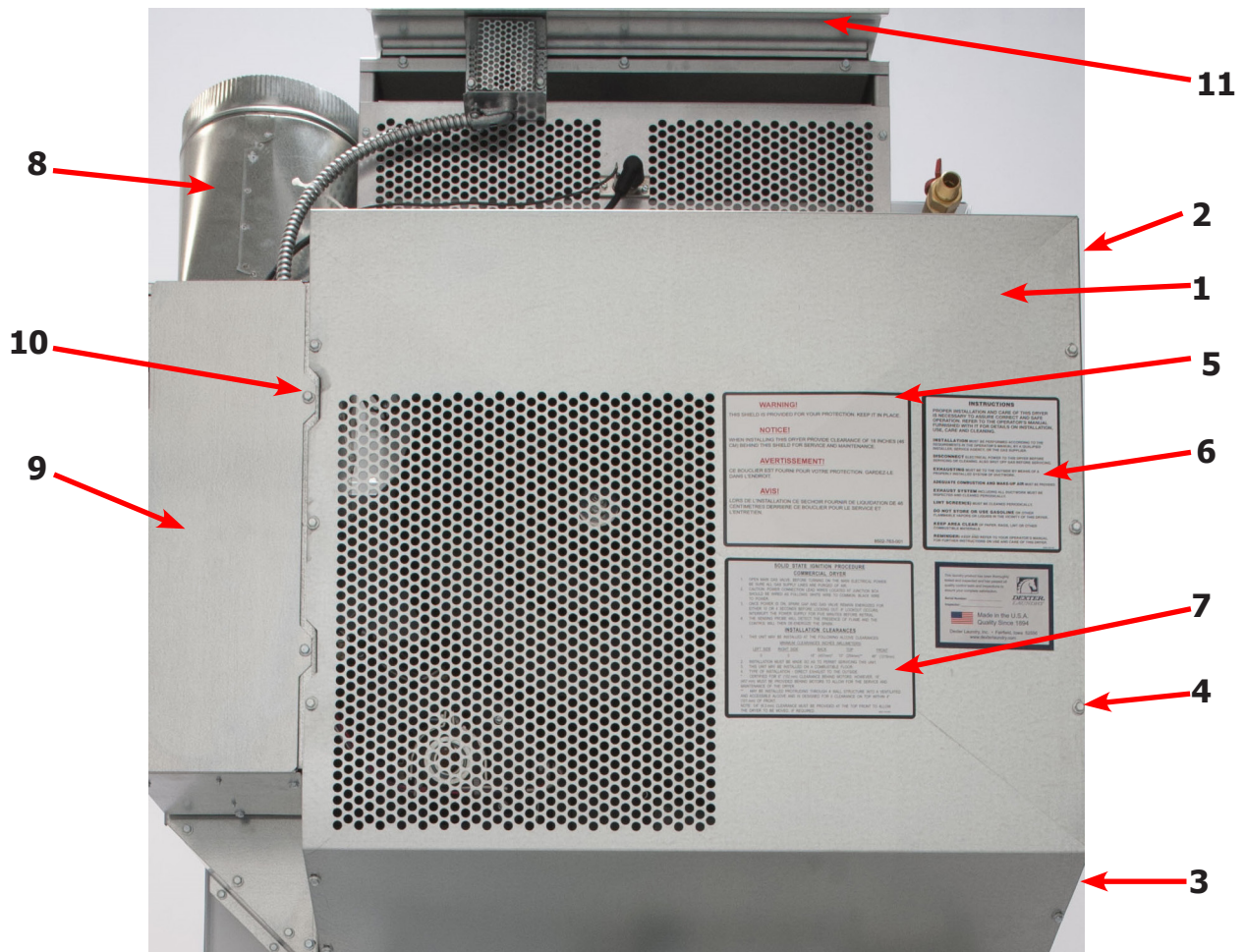

Key	Description	Part Number	Qty
1	Guard, Drive	9208-126-001	1
2	Panel, Drive Guard, RH, Upper	9208-127-001	1
3	Panel, Drive Guard, RH, Lower	9208-128-001	1
4	Screw, 10AB x 3/8	9545-008-024	8
5	Warning, Label	8502-763-001	1
6	Label, Instructions	8502-645-001	1
7	Lighting and Clearance, Label	8527-112-001	1
8	Duct, Transition	9109-113-001	1
9	Door, Cover-Control Box	9108-138-001	1
10	Screw, 10AB x 3/8	9545-008-024	3
*	Cabinet, Cover	9074-371-001	1
*	Insulation	9277-041-017	1
*	Screw, 10AB x 3/8	9545-008-024	3
11	Shield-Burner Inlet	9550-188-001	1
*	Screw, 10AB x 3/8	9545-008-024	4
*	Wiring Diagram & Schematic	9506-789-001	1
*	8" Slide Open Clean Out Duct (Optional)	9973-034-001	1

# Air Flow Switch Assembly

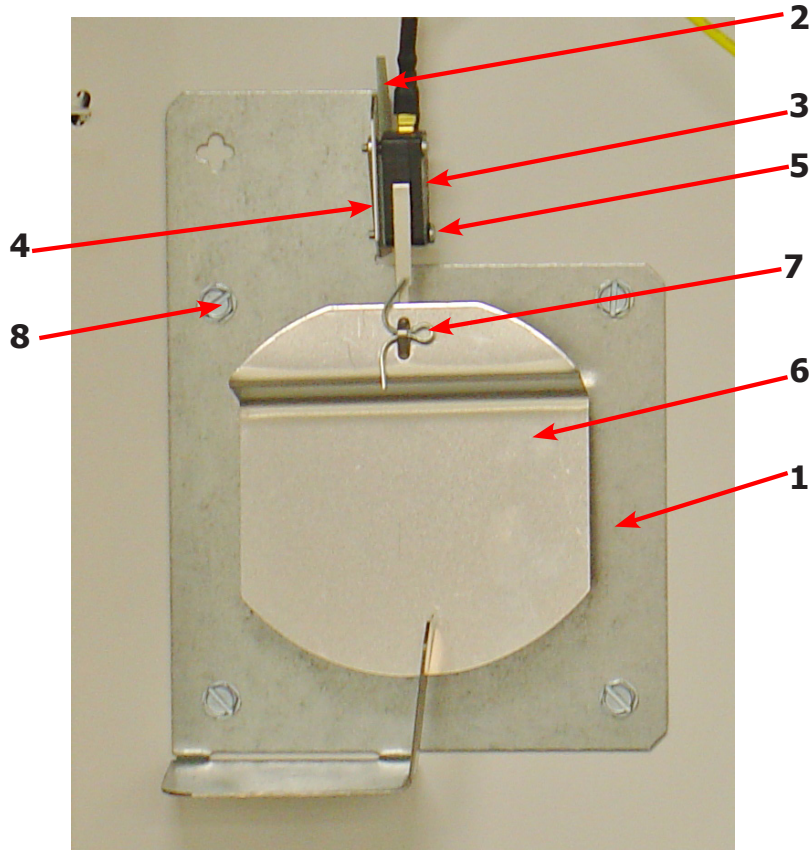

Key	Description	T-50X2-11 Reversing	QTY
*	Air Flow switch Assy	9801-098-001	2
1	Bracket-Airflow switch	9029-200-001	2
2	Shield-Switch	9550-169-003	2
3	Switch-Micro	9539-461-009	2
4	Nut-Twin, 4-40	8640-401-001	2
5	Screw-.625, 4-40	9545-020-001	2
6	Actuator-Air Flow Switch	9008-007-001	2
7	Pin-Cotter, .09375x.75	9451-169-002	2
8	Screw, 10AB x 3/8	9545-008-024	8
*	Harness Assembly, Overtemp/Airflow	9627-861-001	1

## Dryer Burner Housing Group

Key	Description	T-50X2-11 Reversing	QTY
*	Housing Assembly, Burner	9803-230-001	1
1	Service Burner Plate Front	9452-730-001	1
2	Screw, 10B X 1/4"	9545-008-001	4
3	Service Plate baffle Recirculation Chamber Clean Out	9452-850-001	1
4	Screw, 10B x 3/8"	9545-008-006	6
5	Angle, Burner Support	9003-220-001	1
*	Screw, 10B x 3/8"	9545-008-006	2
6	Burner, Main	9048-020-002	2
*	Screw 10AB x 3/8"	9545-008-006	2
*	Panel, Back Burner Housing	9454-992-001	1
7	Electrode Assy, Ignition	9875-002-003	1
8	Screw, Electrode Mtg 8B x 1/4"	9545-045-001	2
9	Valve, Gas Shut Off (Optional)	9379-196-001	1
10	Pipe, 1/2 x 4 1/2, BLK	8665-073-044	1
11	Elbow, 1/2 x 90, BLK	8615-104-037	1
12	Nipple, 1/2 x 4 1/2, BLK	8665-073-008	1
13	Control Assy, Gas	9857-192-001	1
14	Manifold, Assy	9381-012-001	1
*	Orifice, Burner-Natural #29	9425-069-021	2
*	Orifice, Burner-LP #46	9425-069-022	2
15	Bracket, Manifold	9029-175-001	2
16	Pipe Plug in end of Burner Manifold	8615-104-038	1
*	Screw, 10B x 3/8"	9545-008-006	2
*	Bracket, High Limit Thermostat	9029-192-001	1
17	Thermostat, Hi-Limit	9576-203-002	2
*	Spacer, Hi-Limit	9538-142-001	1
*	Screw 8B x 3/4"	9545-045-007	2
18	Cover, Hi-Limit Stat	9074-329-001	1
*	Screw, 10B x 3/8"	9545-008-006	2
19	Thermostat, Safety Shutoff	9576-207-008	1
20	Screw, 10B x 3/8"	9545-008-006	3
21	Cover, Safety Stat	9825-062-001	2
*	Screw, 10AB x 3/8	9545-008-024	3
*	Control, Ignition Fenwall (3 trybox)	9857-182-001	1
*	Kit, LP Conversion	9732-102-032	1
22	Heat Recirculation Duct, (From Exhaust to Burner	9973-032-001	2
*	Screw, 10ABX x 3/8"	9545-008-024	8
23	Shield-Burner Inlet	9550-188-001	1
*	Make-Up Air Vent Kit	9732-334-001	1

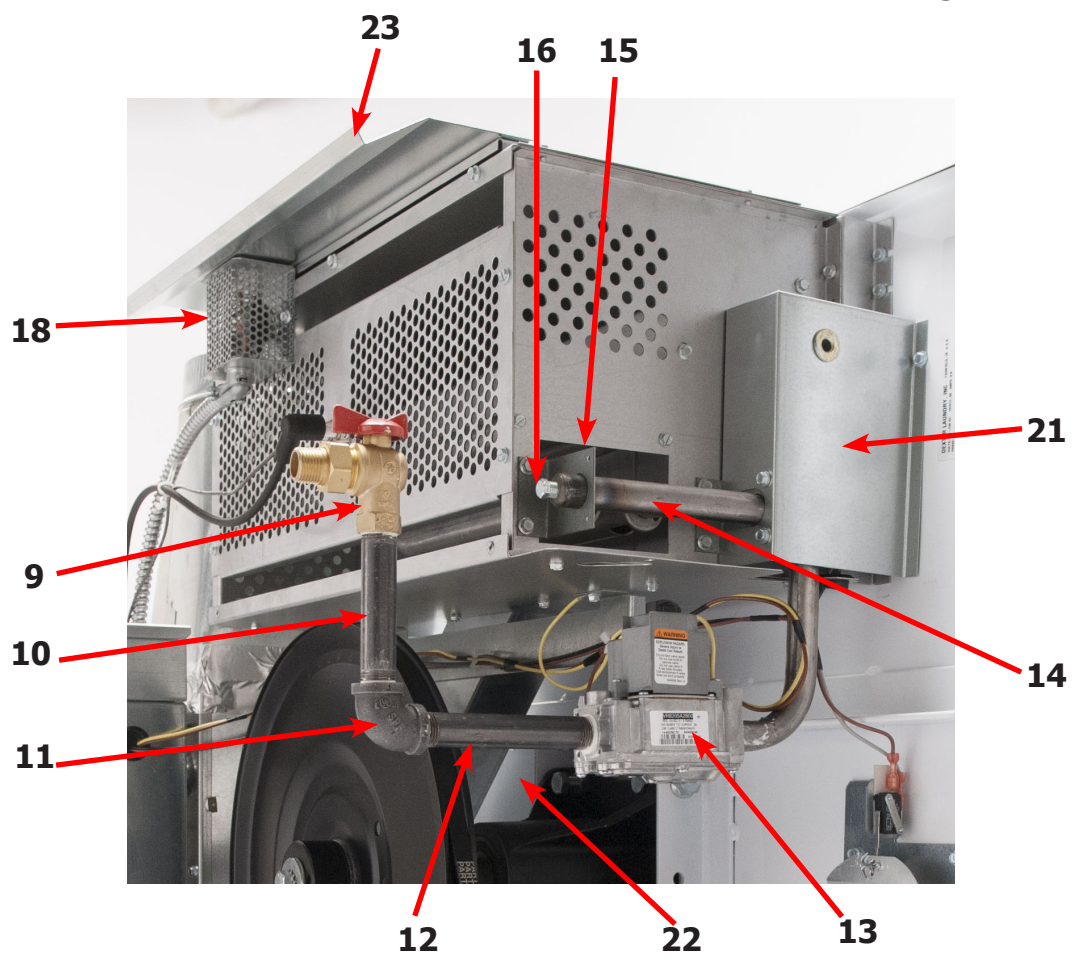
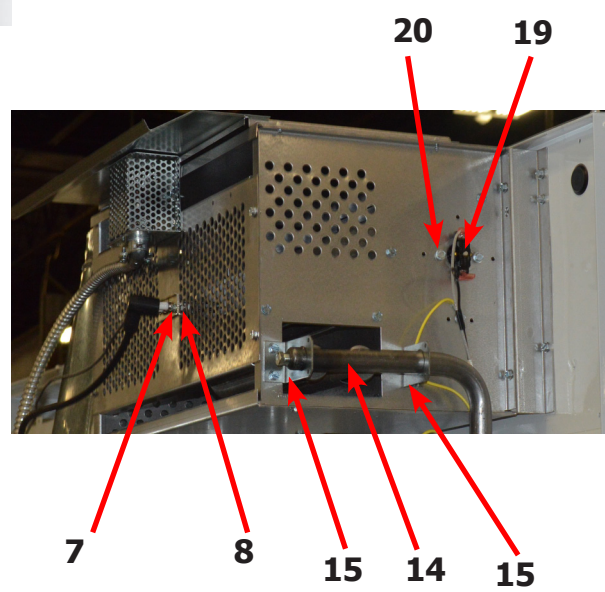
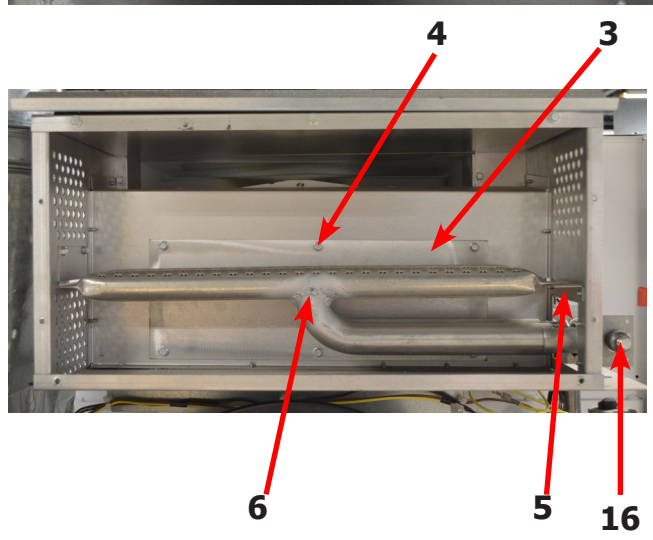
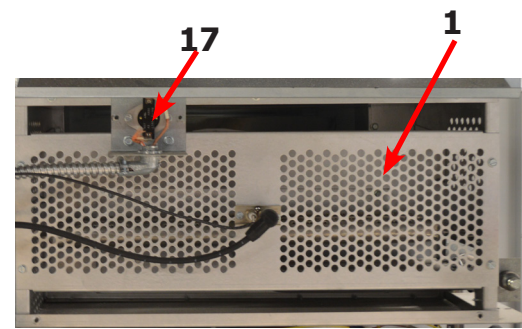
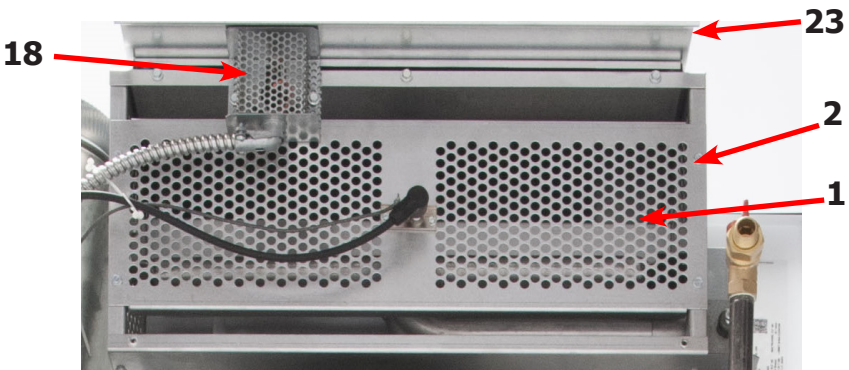

# Bearing Housing Group

Key	Description	T-50X2-11 Reversing	QTY
	Bearing Housing Complete Assy (Includes bearings & Spacer)	9803-201-001	1
1	Housing, Bearing	9241-189-002	1
*	Bearing, Ball, Front	9036-159-001	1
*	Spacer, Bearing	9538-183-001	1
2	Bearing, Ball, Rear	9036-159-003	1
3	Screw-Wizlock, 1/2-13x3/4	9545-017-017	4
4	Nut, 1/2-13	8640-417-002	2
5	Screw, 1/2-13x1 1/2	9545-017-018	2
6	Nut, 1/2-13	8640-417-002	2

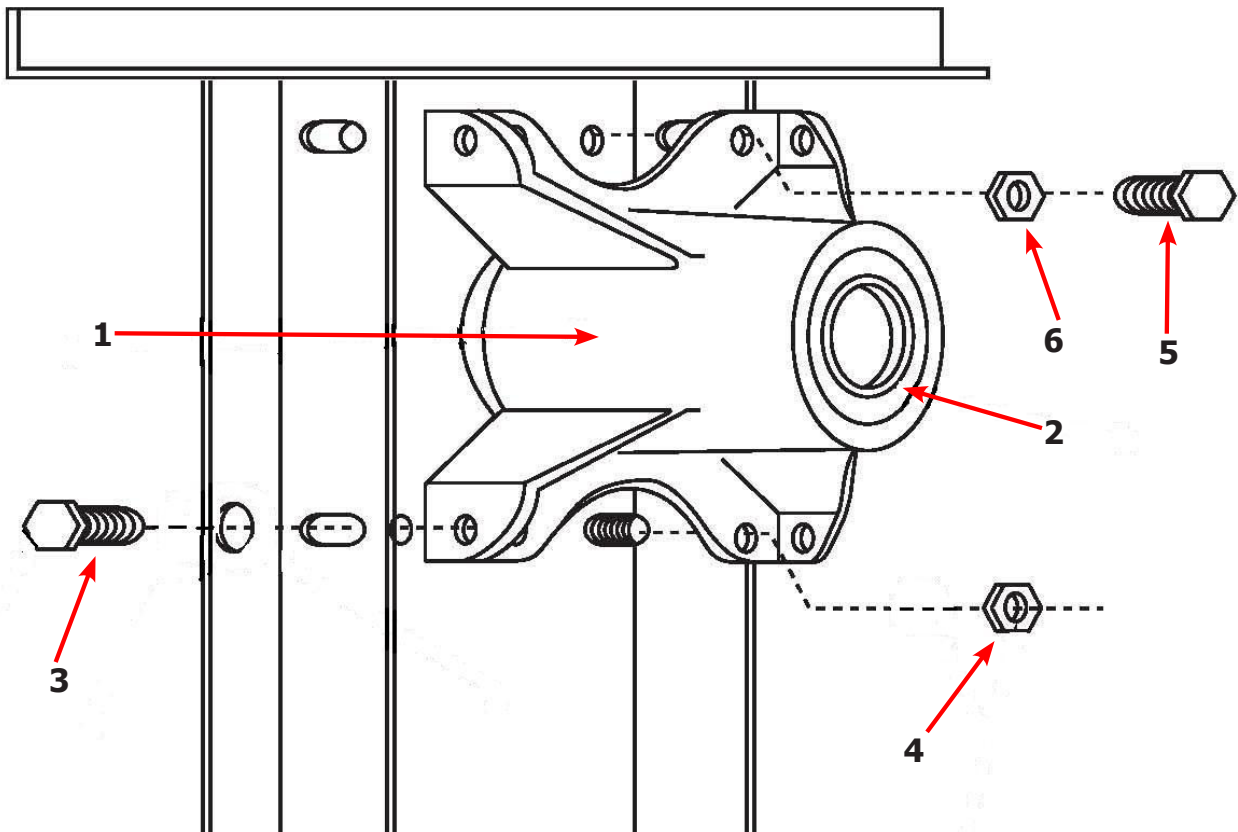
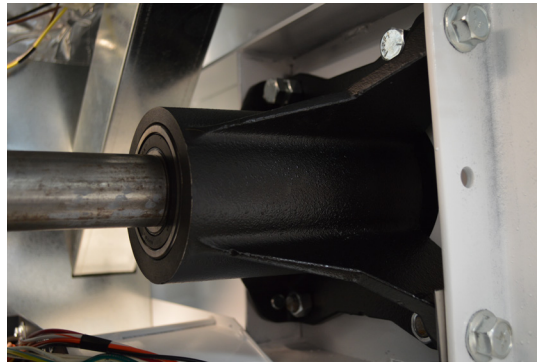

# Tumbler Group

Key	Description	T-50X2-11 Reversing	QTY
*	Tumbler Assy Complete W/Spider (GALV)	9848-154-001	1
1	Tumbler Assy (Galvanized)	9848-148-001	1
*	New Tumbler, Taller Baffles (Anti-Roping) W/Spider	9848-158-001	1
*	New Tumbler, Taller Baffles (Anti-Roping)	9848-157-001	1
*	Tumbler Assy Complete W/Spider (SS & Galv front)	9848-154-002	1
1	Tumbler Assy (Stainless Galvanized front)	9848-148-002	1
2	Rod, Tumbler	9497-226-002	3
3	Washer, Special	8641-590-002	3
4	Shim	9552-013-003	AR
5	Spider Assy	9568-017-001	1
6	Nut, Wiz Lock	8640-417-005	3
7	Spacer-Shaft	9538-188-001	1
8	Tolerance Ring	9487-234-005	1
9	Pulley, Driven	9908-047-002	1
10	Washer -Flat	8641-581-026	1
11	LockWasher - IntTooth, 1"	8641-582-016	1
12	Screw, 1/2-13x1 1/4	9545-017-009	1
*	Belt, Drive	9040-076-003	2

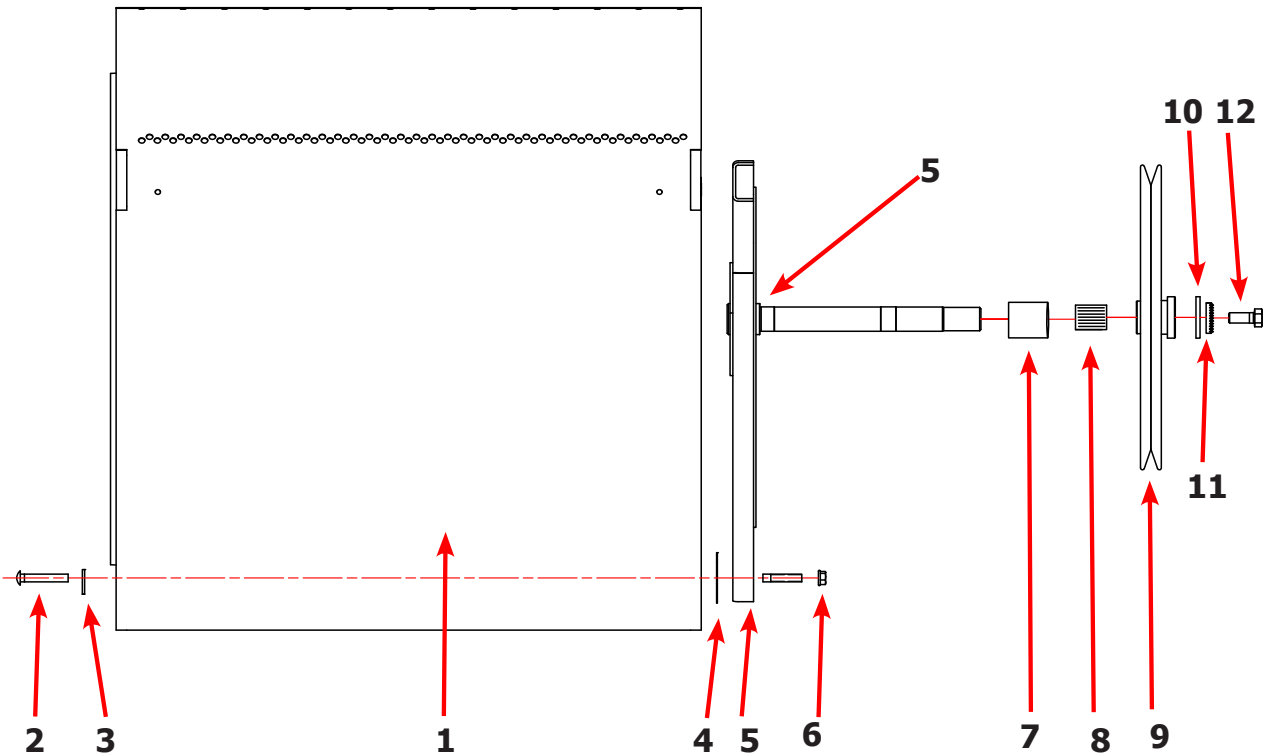

# Dryer Rear View

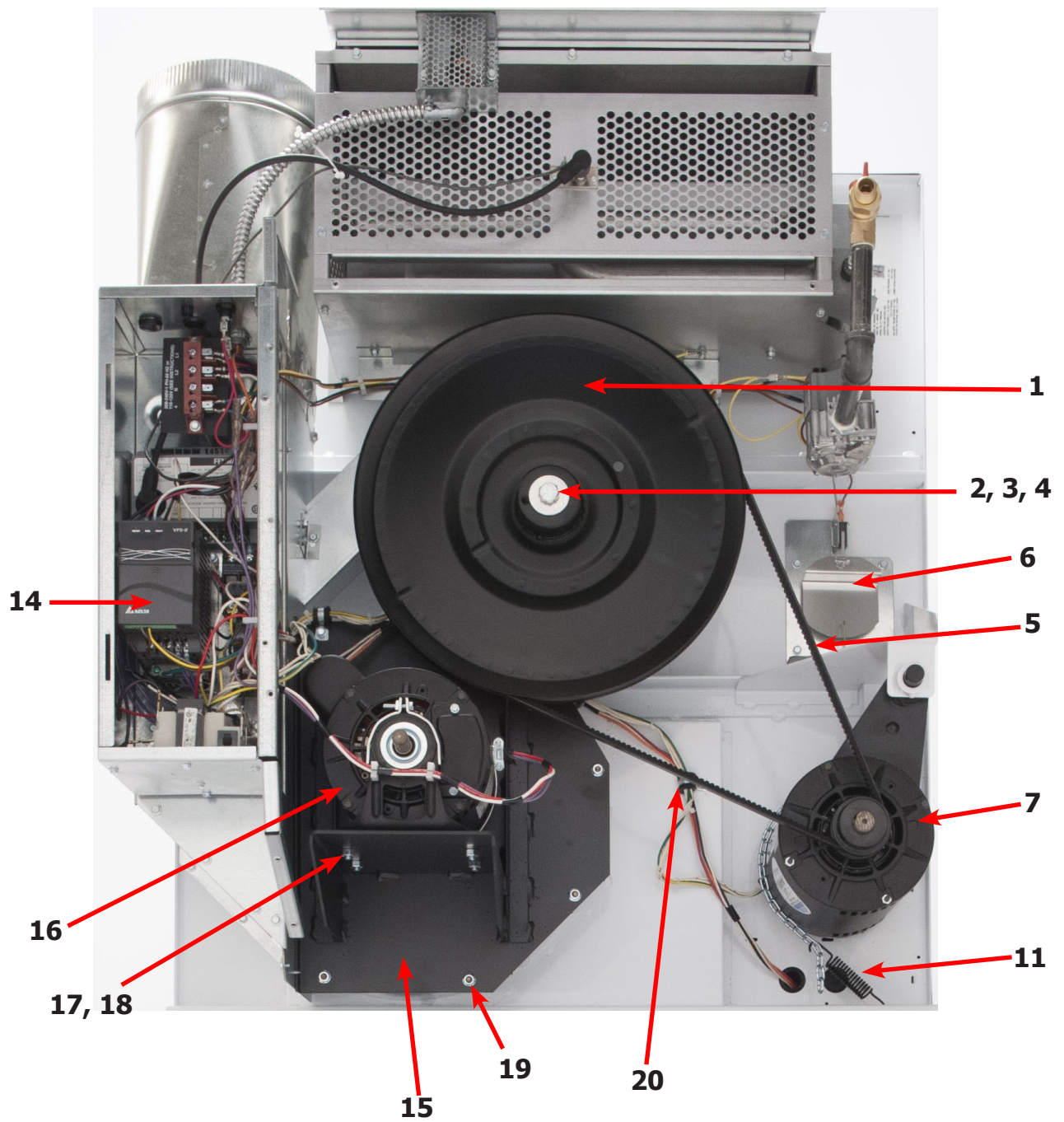

Key	Description	T-50X2-11 Reversing	QTY
*	Spacer, Tumbler pulley	9538-047-002	1
1	Pulley, Driven	9908-047-002	1
*	Tolerance Ring	9487-234-005	1
2	Washer-Flat, 1/2"	8641-581-026	1
3	Lock Washer, 1/2"	8641-582-016	1
4	Bolt, 1/2"-13 x 1" 1/4"	9545-017-009	1
5	Belt, Drive	9040-076-003	1
6	Air Flow Switch, Assembly	9801-098-001	1
7	Motor-Drive, 2Hp.	9376-319-001	1
8	Pulley-Motor, Drive	9453-169-012	1
*	Screw-Set, 5/16"-18 x 1/2"	9545-028-013	2
9	Rod-Motor Mounting	9497-222-008	1
*	Bushing, Motor Support	9053-074-002	2
10	Collar-Shaft, w/Set Screw	9076-052-002	2
11	Spring, Belt Tension	9534-319-002	1
12	Chain, Spring Tension, 15 1/2" (27 Links)	9099-012-008	1
13	Hook, "S" Hook	9248-022-002	1
14	Drive-VF, Inverter, 2Hp 230V (Before 11/2024)	9375-032-011	1
14	Drive-VF, Inverter MS300 (Starting 11/2024)	9375-034-043	1
15	Plate Assembly, Impeller-Blower Motor	9982-388-002	1
16	Motor, Blower	9376-311-005	1
17	Bolt-Motor Mounting, 5/16, 18 x 5/8"	9545-014-004	4
18	Nut, 5/16"-18	8640-400-003	4
*	Impeller, w/Set Screws	9278-043-001	1
19	Nut-1/4" x 20, Mounting Plate, Impeller Motor Assy.	8640-414-007	7
20	Clamp, Conduit/Wiring	8654-126-004	3

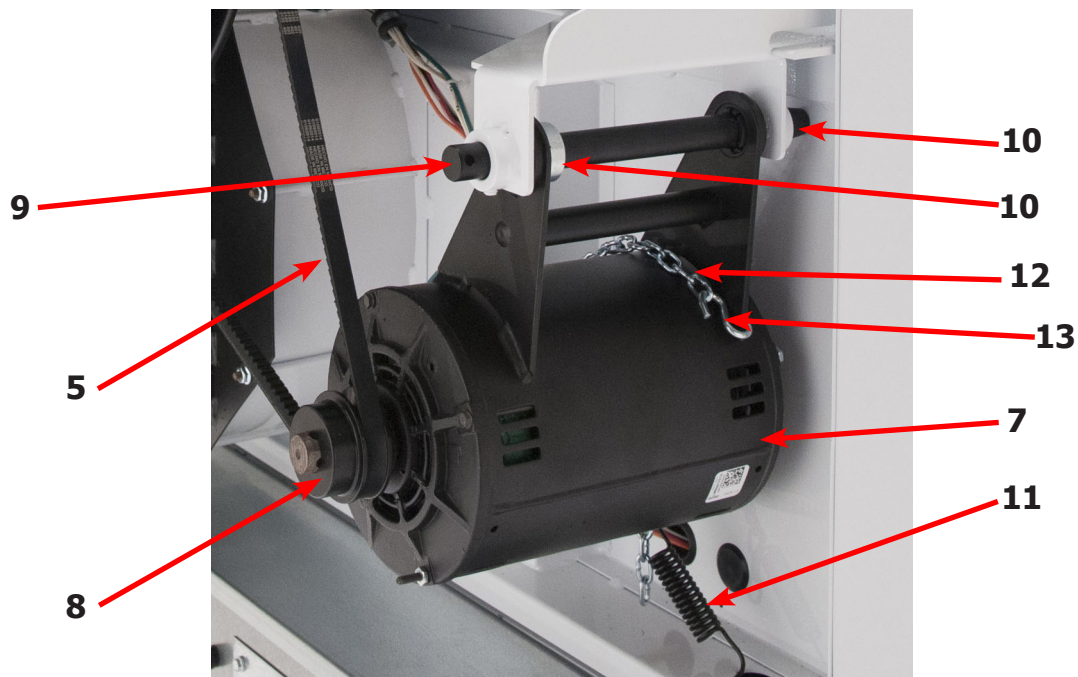

# Control Assembly Group

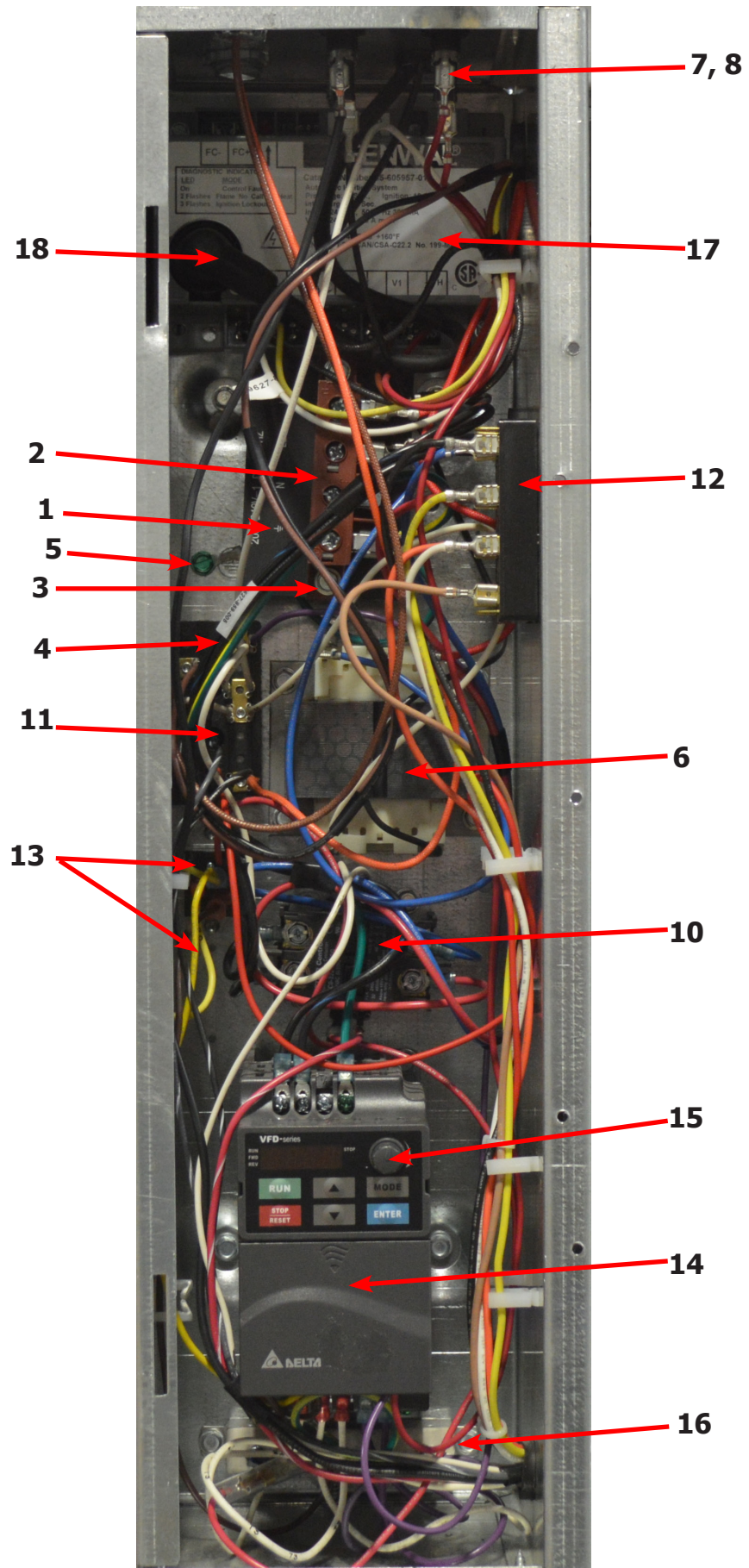

# Control Assembly Group

Key	Description	T-50X2-11 Reversing	QTY
*	Control, Rear	9857-222-003	1
*	Bracket, Terminal Block Power	9029-202-001	1
1	Strip, Terminal Marker	9558-029-006	1
2	Terminal-Block, Power,	9897-035-001	1
3	Screw, 10AB x 3/8"	9545-008-024	1
*	Harness Assembly-Power Main Fork, Upper	9627-859-005	1
4	Wire Assembly-Ground, GRN/YEL, 7"	8220-137-002	1
*	Lock Washer, Ext tooth #10	8641-582-006	1
5	Screw, 10-32 x 1"	9545-008-027	1
6	Transformer, 208/240/60Hz. 24/120VA	8711-013-001	1
*	Screw, 10AB x 3/8"	9545-008-024	2
7	Fuse Holder Assembly	9200-001-002	1
8	Fuse, 1.5Amp/250V-Fast Acting	8636-018-001	1
10	Relay, Motor, 30Amp 24VAC	5192-299-002	1
*	Screw, Phillips, 8AB x 1/2"	9545-045-012	2
11	Terminal Block, Power	9897-026-003	1
*	Screw, Phillips, 8AB x 1/2"	9545-045-012	2
12	Terminal Block Power	9897-026-002	1
*	Screw, Phillips, 8AB x 1/2"	9545-045-012	2
13	Relay-Enable, 24Vac 50/60Hz	5192-285-004	2
*	Screw, Phillips, 8AB x 3/8"	9545-045-008	2
14	Drive-Inverter, 230V (Before 11/2024)	9375-032-011	1
14	Drive-Inverter MS300 (Starting 11/2024)	9375-034-043	1
*	Screw-Mounting, 10B x 1/2"	9545-008-026	4
15	Key-Pad, Display, Delta E-Drive	9150-044-001	1
16	Resister-Dynamic Breaking, 200Ohm	9483-004-002	1
*	Screw, 10AB x 3/8"	9545-008-024	2
*	Wire Assembly, Violet, 8"	8220-118-003	2
*	Screw, #6-32 x 5/16"	9545-044-006	2
*	Nut, Hexkeps, #6-32	8640-411-003	2
*	Harness-Assembly, Low Voltage, Upper	9627-867-007	1
17	Ignition Module	9857-182-001	1
*	Screw, 10AB x 3/4"	9545-008-018	2
18	Wire Assembly, High Voltage	9631-403-009	1
*	Door-Control Box	9108-138-001	1
*	Screw, 10AB x 3/8"	9545-008-024	3

# Control Group

Key	Description	T-50X2-11 Reversing	QTY
	Control Assembly	9857-222-002	1
1	Membrain Switch OPL Black	9801-112-001	1
*	Wire Assembly Green/Yellow	8220-137-002	1
2	Nut-Hex #6-32	8640-411-003	1
3	Nut-Hex #6-32	8640-411-001	3
4	PCB Assyembly-Controller opl	9471-016-001	1
5	Plastic Spacer #6x1/2	9538-157-016	4
6	Plate Assembly opl ptd	9982-391-002	1

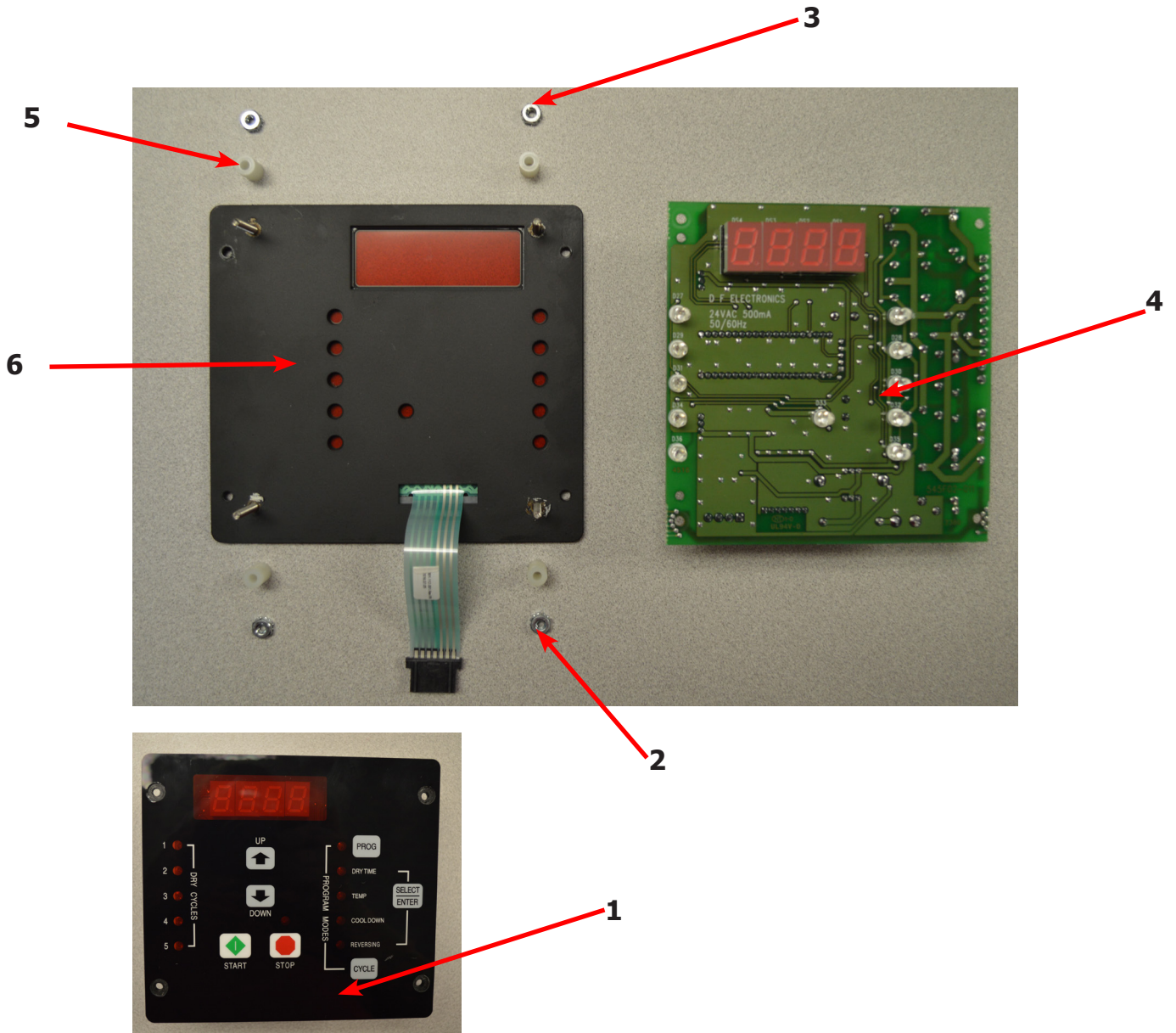



# 60Hz Wiring Diagram Dryer

9506-789-001D

WIRING DIAGRAM

DN5050NC-11EB\_R-\_\_\_X

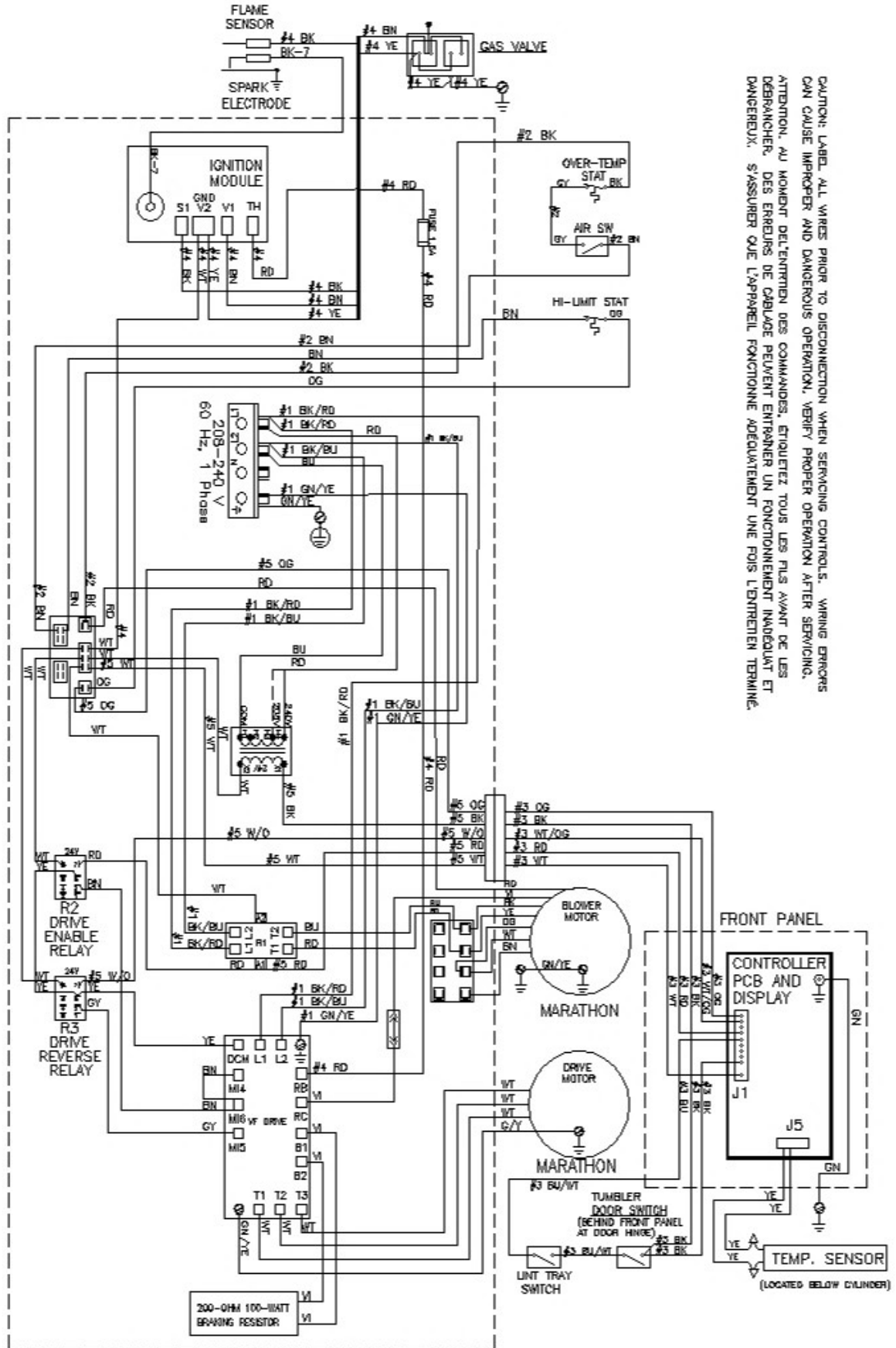

CAUTION: LABEL ALL WIRES PRIOR TO DISCONNECTION WHEN SERVICING CONTROLS. WIRING ERRORS CAN CAUSE IMPROPER AND DANGEROUS OPERATION. VERIFY PROPER OPERATION AFTER SERVICING. ATTENTION: AU MOMENT DE L'ENTRÉE EN COMMANDE, ÉTIQUÉTEZ TOUTS LES FILS AVANT DE LES DÉBRANCHER. DES ERREURS DE CÂBLAGE PEUVENT ENTRAÎNER UN FONCTIONNEMENT INADÉQUAT ET DANGEREUX. S'ASSUREZ QUE L'APPAREIL FONCTIONNE ADÉQUATEMENT UNE FOIS L'EXTREMIÉTÉ TERMINÉE.

# 60Hz Schematic Dryer

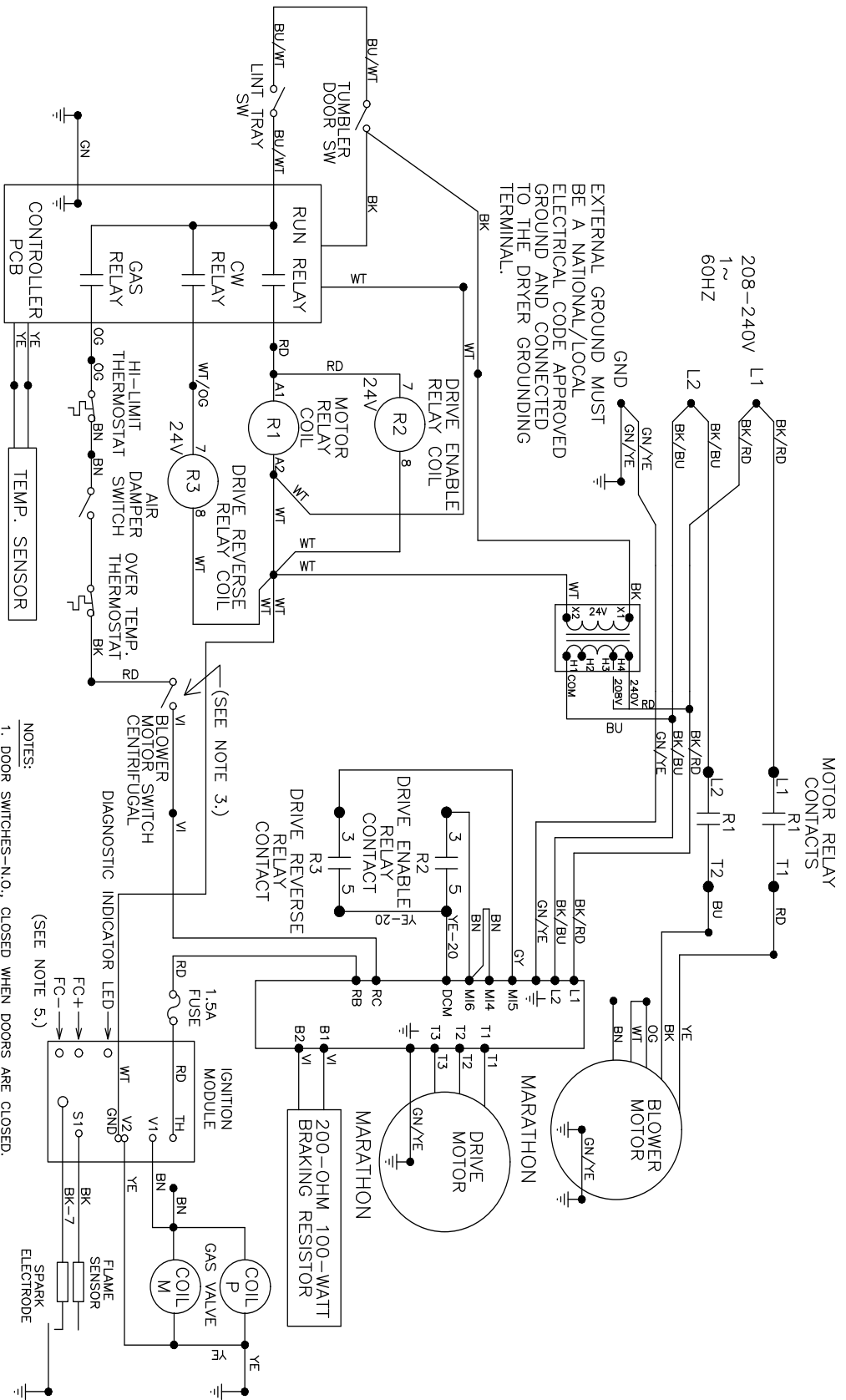

EXTERNAL GROUND MUST BE A NATIONAL/LOCAL ELECTRICAL CODE APPROVED GROUND AND CONNECTED TO THE DRYER GROUNDING TERMINAL.

CAUTION: LABEL ALL WIRES PRIOR TO DISCONNECTION WHEN SERVICING CONTROLS. WIRING ERRORS CAN CAUSE IMPROPER AND DANGEROUS OPERATION. VERIFY PROPER OPERATION AFTER SERVICING.  
 ATTENTION: AU MOMENT DE L'ENTRIEN DES COMMANDES, ÉTIQUETEZ TOUTS LES FILS AVANT DE LES DÉBRANCHER. DES ERREURS DE CÂBLAGE PEUVENT ENTRAINER UN FONCTIONNEMENT INADÉQUAT ET DANGEREUX. S'ASSURER QUE L'APPAREIL FONCTIONNE ADEQUATEMENT UNE FOIS L'ENTRIEN TERMINÉ.

- NOTES:
1. DOOR SWITCHES-N.O., CLOSED WHEN DOORS ARE CLOSED.
  2. DRYER STARTS WHEN THE DOORS ARE CLOSED, A CYCLE IS SELECTED, AND THE START BUTTON IS PUSHED. THERE IS AN AUTOMATIC COOL DOWN AT THE END OF THE CYCLE.
  3. CENTRIFUGAL SWITCH-N.O., CLOSSES WHEN MOTOR IS UP TO SPEED.
  4. REFER TO OWNER'S MANUAL FOR DESCRIPTION OF OPERATION AND REQUIREMENTS FOR HEATING CIRCUIT.
  5. WITH A DC MICROAMMETER, FLAME CURRENT CAN BE MEASURED AT TEST POINTS. READING SHOULD BE 0.7uA DC OR HIGHER.

9506-789-001D

SCHEMATIC

DNS050NC-11EB\_R-----X



---

# **Section: 7**

## 50 Hz Gas Dryer

## Rear View Photos

	Description	T-50 SWD-39 Reversing	QTY
*	Spacer, Tumbler pulley	9538-047-002	1
1	Pulley, Driven	9908-047-002	1
*	Tolerance Ring	9487-234-005	1
2	Washer-Flat, 1/2"	8641-581-026	1
3	Lock Washer, 1/2"	8641-582-016	1
4	Bolt, 1/2"-13 x 1" 1/4"	9545-017-009	1
5	Belt, Drive	9040-076-003	1
6	Air Flow Switch, Assembly	9801-098-002	1
7	Motor-Drive, 2Hp.	9376-319-001	1
8	Pulley-Motor, Drive	9453-169-012	1
*	Screw-Set, 5/16"-18 x 1/2"	9545-028-013	2
9	Rod-Motor Mounting	9497-222-008	1
*	Bushing, Motor Support	9053-074-002	2
10	Collar-Shaft, w/Set Screw	9076-052-002	1
11	Spring, Belt Tension	9534-319-002	1
12	Chain, Spring Tension, 15 1/2" (27 Links)	9099-012-008	1
13	Hook, "S" Hook	9248-022-002	1
14	Drive-VF, Inverter, 2Hp 230V	9375-032-011	1
15	Plate Assembly, Impeller-Blower Motor	9982-388-002	1
16	Motor, Blower, 50HZ.	9376-311-004	1
17	Bolt-Motor Mounting, 5/16, 18 x 5/8"	9545-014-004	4
*	Nut, 5/16"-18	8640-400-003	4
*	Impeller, w/Set Screws	9278-043-001	1
18	Nut-1/4" x 20, Mounting Plate, Impeller Motor Assy.	8640-414-007	7

# Rear View Photos

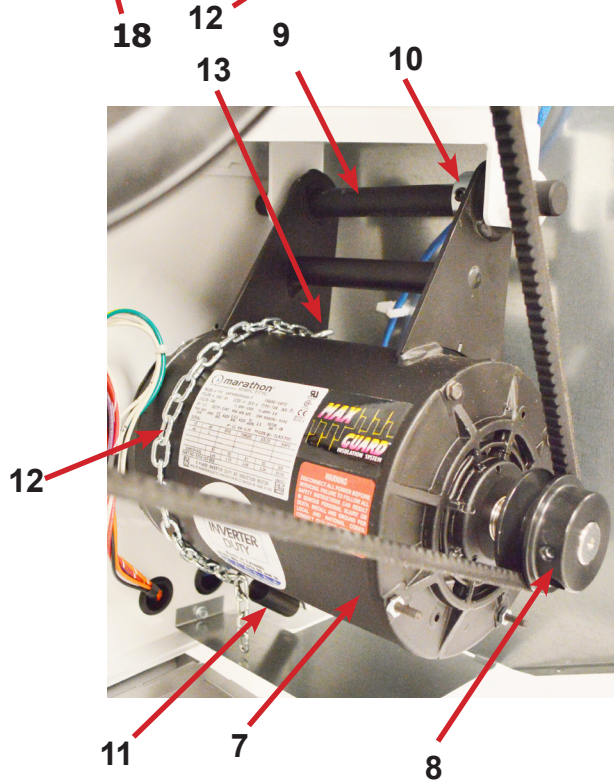
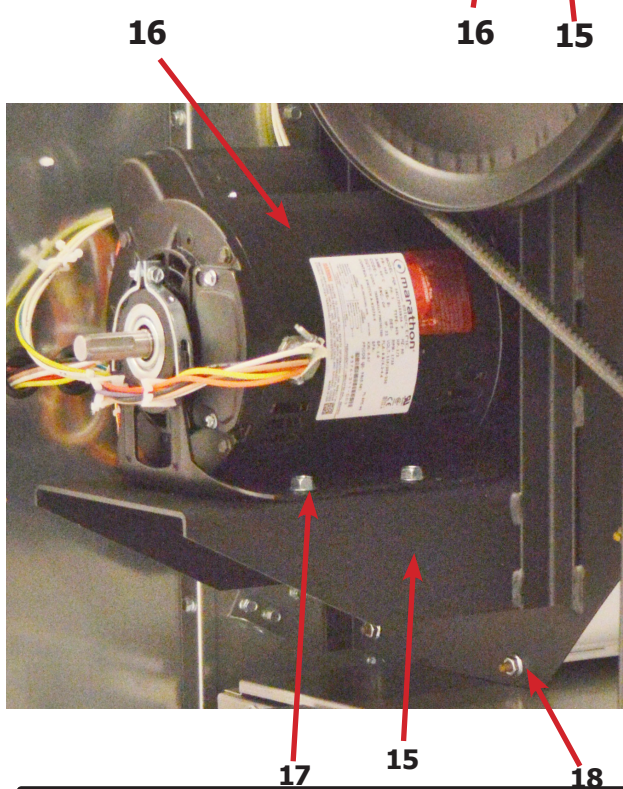
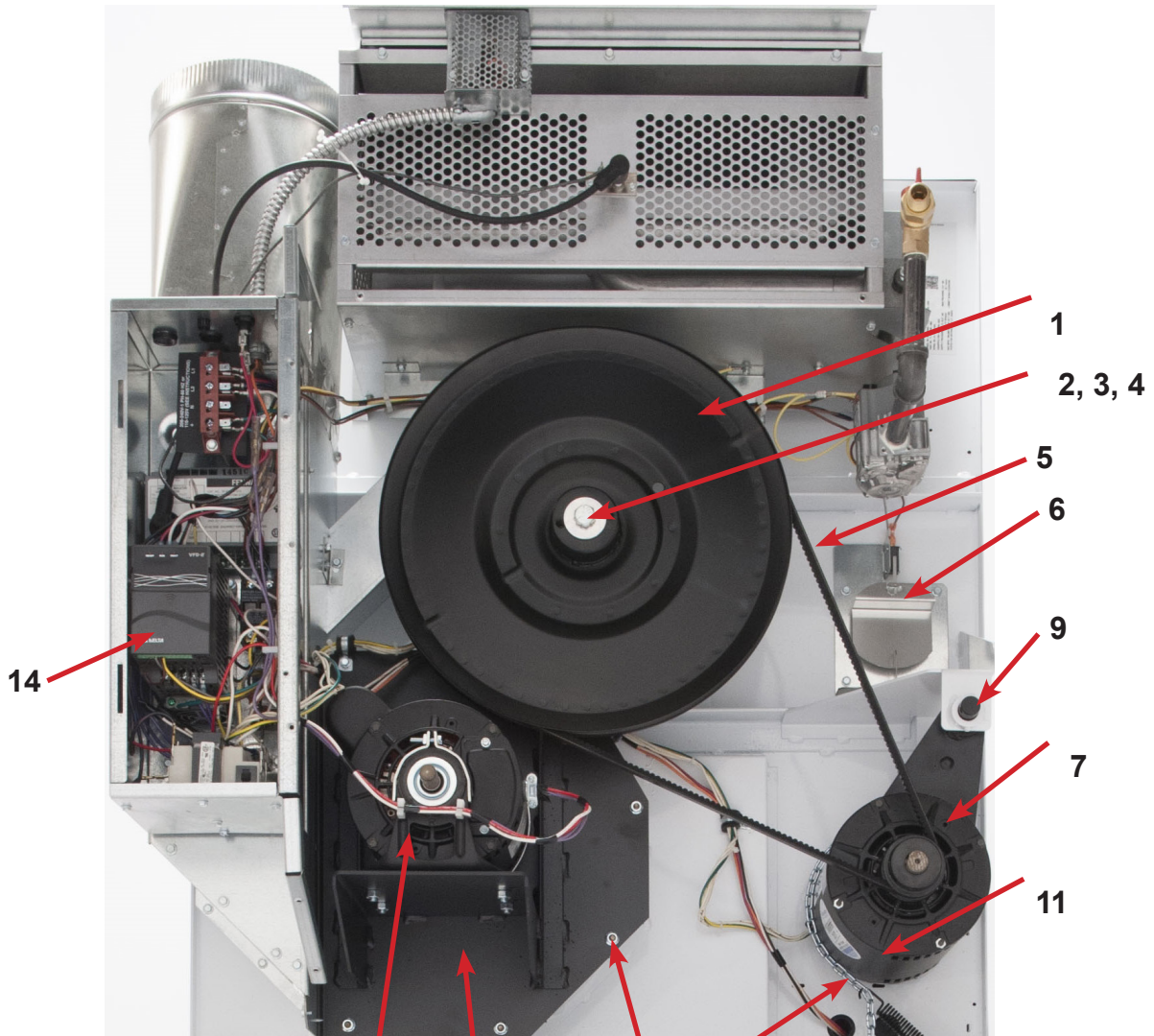

# Electrical Components

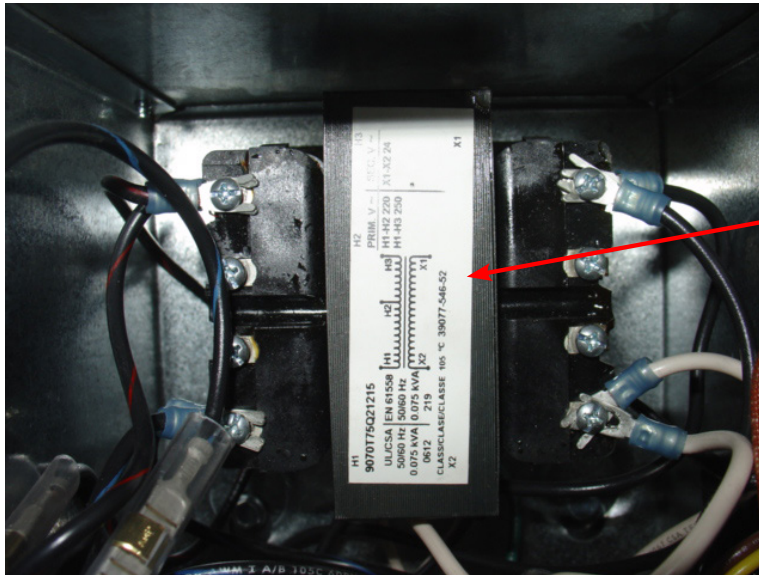

Key	Description	T-50 SWD-39 Reversing	QTY
1	Transformer, 200/230-24 VAC, 50/60HZ	8711-004-004	1
*	Strip-Marker, Terminal	9558-029-004	1

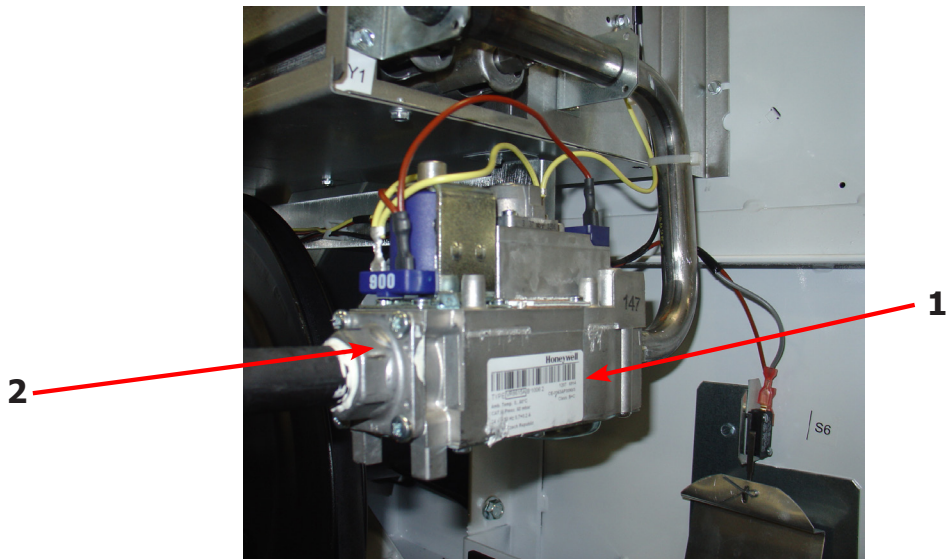

Key	Description	T-50X2-49 Reversing	QTY
1	Control Assembly, Gas Valve	9857-132-004	1
2	Kit-Honeywell VR86, Valve Flange assy	9732-162-001	2
*	Orifice, Main Burner, #30	9425-069-002	2
*	LP Kit	9732-102-035	1

# Air Flow Switch Assembly

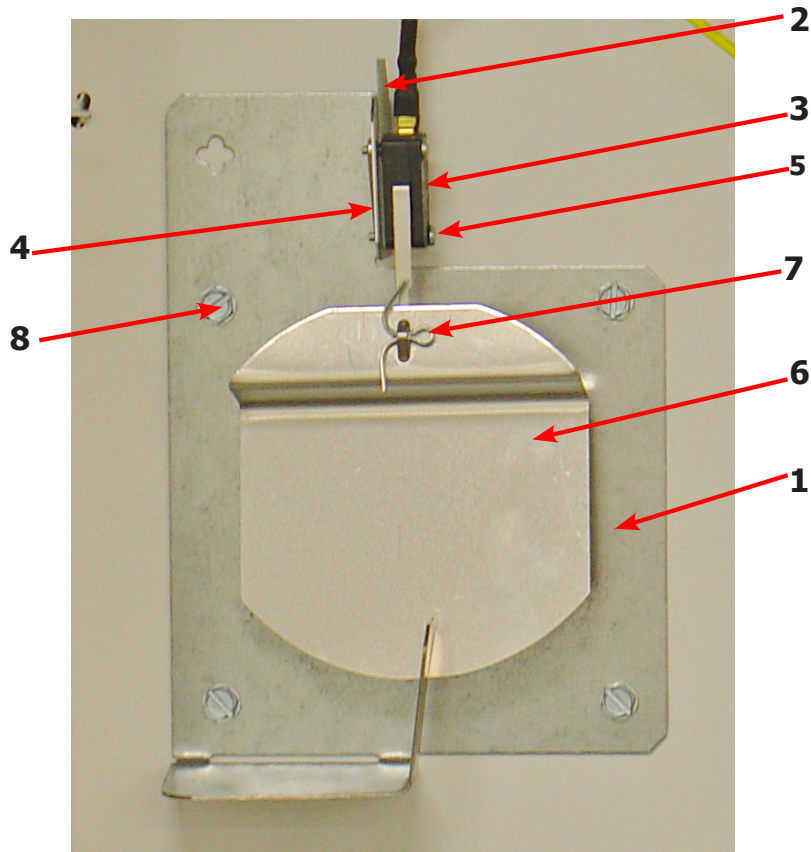

	Description	T-50 SWD-39 Reversing	
*	Air Flow switch Assy	9801-098-002	1
1	Bracket-Airflow switch	9029-200-002	1
2	Shield-Switch	9550-169-003	1
3	Switch-Micro	9539-461-009	1
4	Nut-Twin, 4-40	8640-401-001	1
5	Screw-.625, 4-40	9545-020-001	1
6	Actuator-Air Flow Switch	9008-007-001	1
7	Pin-Cotter, .09375x.75	9451-169-002	1
8	Screw, 10ABx3/8	9545-008-024	4
*	Harness Assembly, Overtmp/Airflow	9627-861-001	1

# Wiring Schematic for Dryer 50hz 230V -21CR

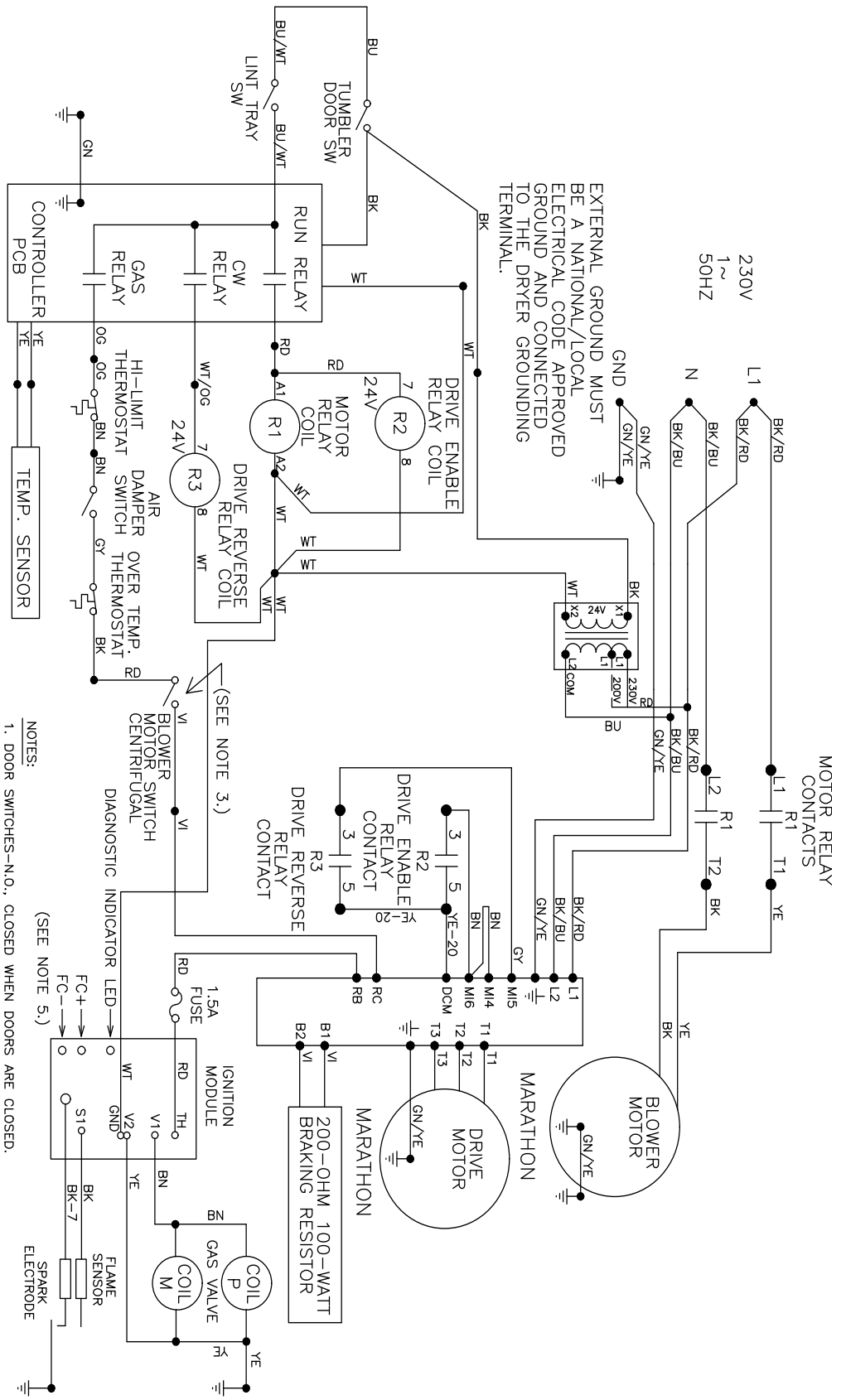

EXTERNAL GROUND MUST BE A NATIONAL/LOCAL ELECTRICAL CODE APPROVED GROUND AND CONNECTED TO THE DRYER GROUNDING TERMINAL.

CAUTION: LABEL ALL WIRES PRIOR TO DISCONNECTION WHEN SERVICING CONTROLS. WIRING ERRORS CAN CAUSE IMPROPER AND DANGEROUS OPERATION. VERIFY PROPER OPERATION AFTER SERVICING.

ATTENTION: AU MOMENT DEL'ENTRIEN DES COMMANNES, ETIQUETEZ TOUS LES FILS AVANT DE LES DEBRANCHER. DES ERREURS DE CABLAGE PEUVENT ENTRAINER UN FONCTIONNEMENT INADQUAT ET DANGEREUX. S'ASSURER QUE L'APPAREIL FONCTIONNE ADEQUATEMENT UNE FOIS L'ENTRIEN TERMINE.

9506-816-001A

SCHEMATIC

DNS050NC-39XB\_R-X

- NOTES:
1. DOOR SWITCHES-N.O., CLOSED WHEN DOORS ARE CLOSED.
  2. DRYER STARTS WHEN THE DOORS ARE CLOSED, A CYCLE IS SELECTED, AND THE START BUTTON IS PUSHED. THERE IS AN AUTOMATIC COOL DOWN AT THE END OF THE CYCLE.
  3. CENTRIFUGAL SWITCH-N.O., CLOSSES WHEN MOTOR IS UP TO SPEED.
  4. REFER TO OWNER'S MANUAL FOR DESCRIPTION OF OPERATION AND REQUIREMENTS FOR HEATING CIRCUIT.
  5. WITH A DC MICROAMMETER, FLAME CURRENT CAN BE MEASURED AT TEST POINTS. READING SHOULD BE 0.7uA DC OR HIGHER.

# Wiring Diagram for Dryer 50hz 230V -21CR

9506-816-001A

WIRING DIAGRAM

DNS050NC-39XB\_R-\_\_\_\_\_X

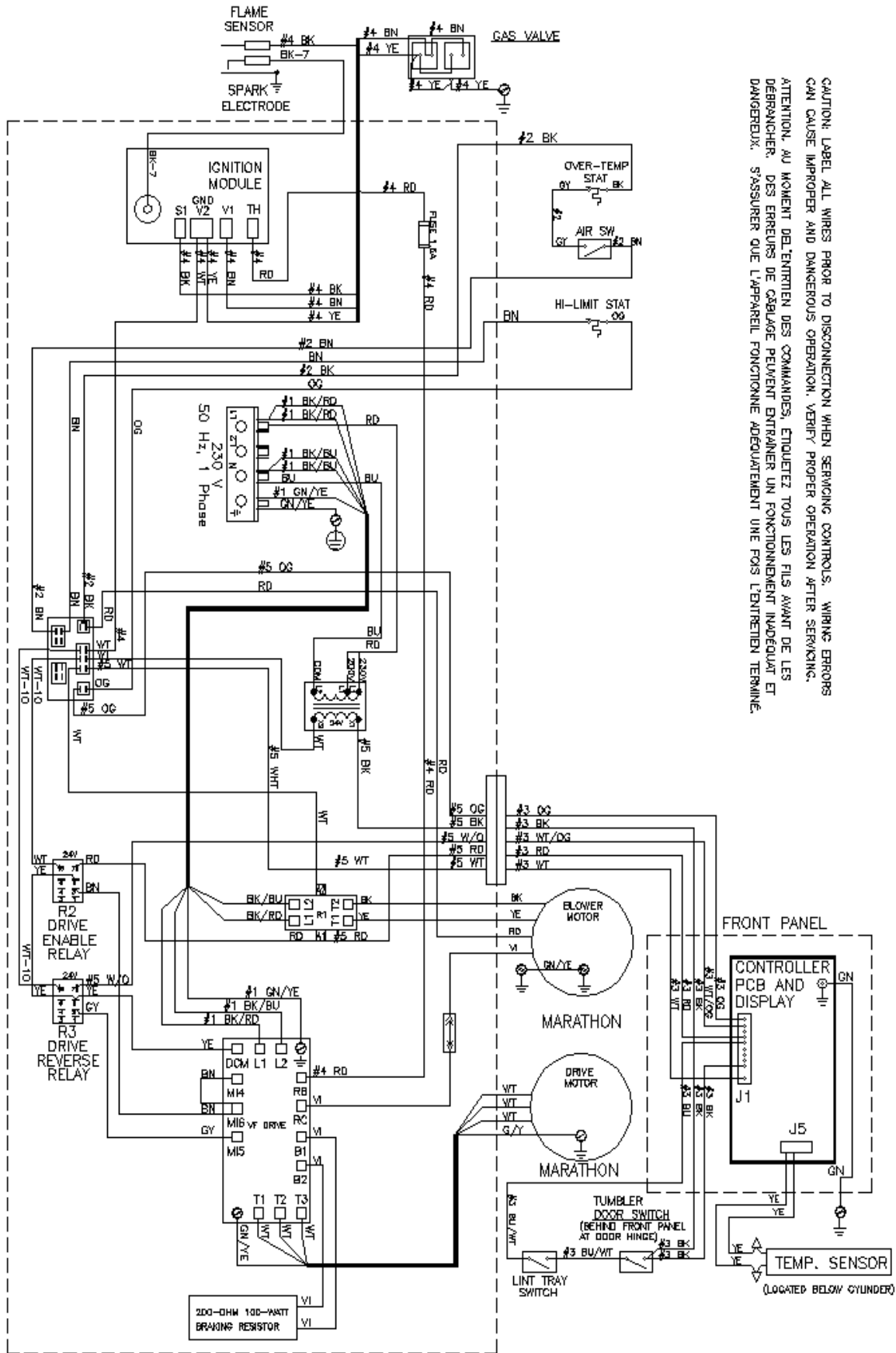



---

# **Section: 8**

## Washer Service and Trouble Shooting

## Front Soap Box removal

- Step 1:** Remove front Panel
- Step 2:** Remove the six 3/8 nuts and remove Soap Box mounting bracket and Soap Box, followed by removing gasket.
- Step 3:** Reassemble reverse operation.

**Note:** Be sure to note position of washers and spacers behind mounting bracket.

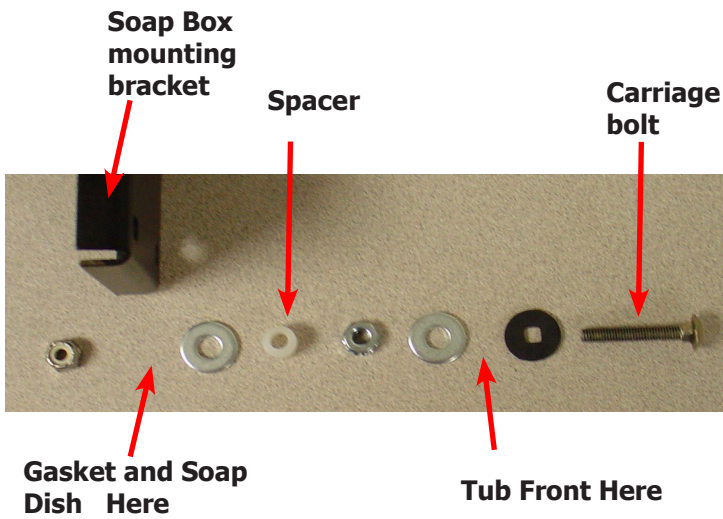

---

## Front Panel Removal

- Step 1:** Remove the screws from front panel.
- Step 2:** Remove the harness connections from the control boards on the back of the front panel
- Step 3:** Pull back the front panel and set it aside.

## Back Panel Removal

- Step 1:** Remove all screws holding back panel in position except the bottom row.
- Step 2:** The bottom row of screws are slotted and only need to be loosened and to lift off panel.

**NOTE:** The back panel is not only a safety requirement but also contributes to the rigidity of the cabinet.

## Drain Valve Access

For access to drain valve, remove the front panel. The drain valve is a ball type and is powered closed by the drain valve motor. It is mounted under the washer tub on the left side. It is spring loaded open. If power is interrupted to the washer, the motor releases the sealing ball, allowing the drive spring to open the valve. With the valve open, all water in the washer will drain out.

## Drain Valve Cleaning

- Step 1:** Loosen the clamp on the tub hose at the drain valve end and remove the hose from the drain valve.
- Step 2:** Loosen the drain hose clamp on the back of the drain valve. Remove two drain valve mounting racket screws from the frame of the washer.
- Step 3:** **Disconnect Brown/Yellow & Blue wire connection at clear connector.**
- Step 4:** Remove the drain valve and bracket assembly. Unplug the wiring after the drain valve is removed from the washer.

## Detergent Dispenser

The detergent dispenser is located at the top of the front panel. It is fed water from the vacuum breaker assembly at the rear of the machine to flush the soap with hot water during the wash bath and the fabric softener with cold water during the rinse bath.

## Vacuum Breaker (also called an air gap)

In the left rear of the cabinet is the vacuum breaker. It guides the water to the tub and dispenser and prevents a back flow of water.

## Door Locking Gear Motor Assembly

The door locking gear motor is rotated shut with control voltage to lock the door and releases when voltage is removed. It is located in the left front corner of the washer.

## Thermoactuators

The thermoactuators are a safety device that keeps the door from immediately unlocking if power is lost while the machine is operating. They are mounted under the door locking solenoid.

## Lock Thermoactuator

Control voltage is applied to the lock thermoactuator at the beginning of the cycle making it extend and block the door locking gear motor. This keeps the door locked for approximately two minutes after a power failure occurs. The lock thermoactuator does not delay the door opening at the end of a normal cycle.

## Unlock Thermoactuator

To insure that the lock thermoactuator has retracted by the end of the cycle, one minute prior to the end of the cycle, the unlock thermoactuator is powered with control voltage making it extend and unblock the door locking gear motor.

## Drive Belt Removal

Turn the drive pulley while applying pressure to the drive belt until it rolls off of the basket pulley first and then remove from the motor pulley. Be cautious not to drop the motor which could unhook the tension assembly.

Reverse this procedure for installation.

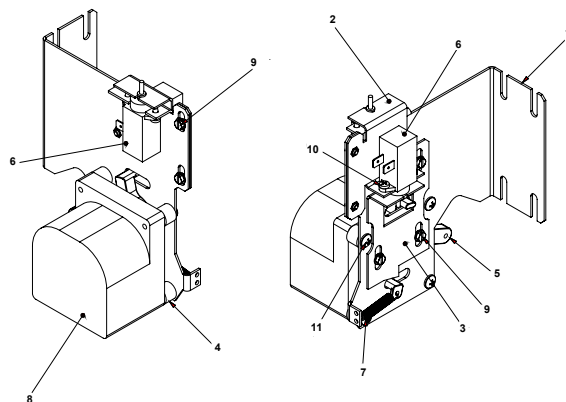

Door Lock Gear Motor

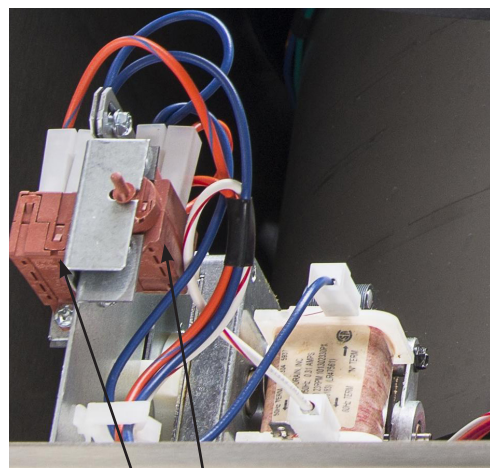

Thermoactuators



Drive Belt

## Water Valves

Remove panel to access water valves at rear. The two dual outlet water valves are mounted to this plate. Always check inlet screens to be sure that they are clean. Disassembly of valve requires the removal of two solenoid screws and three valve body screws. Inside the solenoid coil is a solenoid guide, armature spring and diaphragm. All valve parts are available individually or as a complete unit.

## Door Lock Assembly Operation

After loading the clothing, the door should be closed and latched. The locking cam on the door contacts the latching switch actuator which closes the latching switch. The specified number of coins should now be added to start the washer. The solenoid pulls up on the locking pawl by use of a linkage rod. The locking pawl has two jobs. The first is to lock the door. This is accomplished by blocking the locking cam on the door so that it can't rotate to unlock. The second job is to close the two piggyback lock sensing switches. These switches control power to all of the controls. If the door unlocks for any reason, these two switches will stop the machine. When the door handle is 1/4 to 1/2 of an inch from its fully closed position, the latching switch should close. The two piggyback lock sensing switches should be open when the door is unlocked and should be closed when the door is locked.

## Accessing the Door Lock Assembly

After removing the front panel and masking ring, the door lock assembly can now be accessed.

## Adjustment for Door Lock Assembly

The latching switch and the piggyback lock sensing switches all have slotted mounting for easy adjustment.

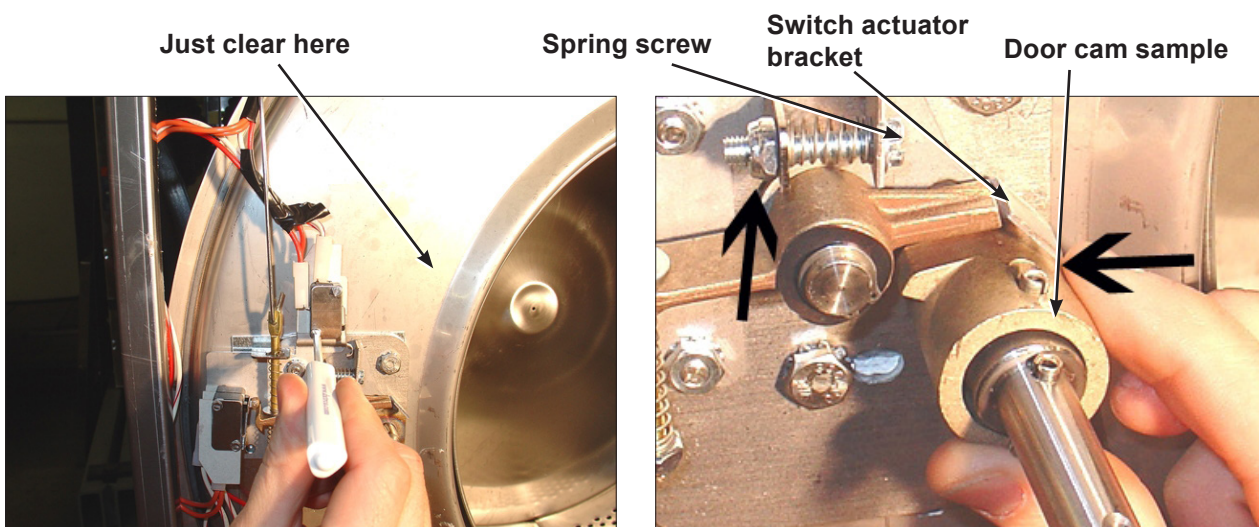

- Step 1:** Set door cam over pin. Here you can see the door cam away from the door lock assembly.
- Step 2:** Tighten spring screw on switch actuator bracket arm until it just clears cam OD. at base of door lock assembly.

Adjustment to this bracket usually is not necessary as next step is used more in field.

Flat blade screw on door switch latching

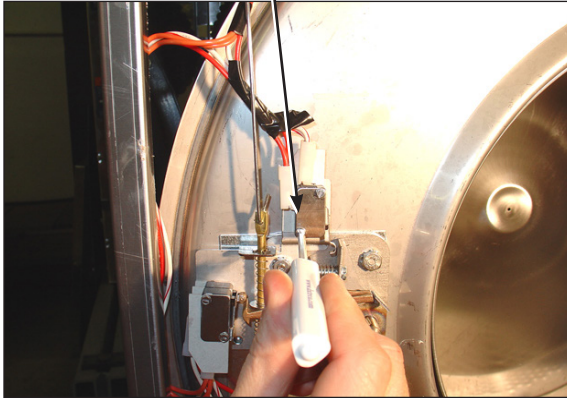

**Step 3:** With switch actuator bracket adjusted you will now need to adjust single switch by loosening 2 flat blade screws and allowing swivel of switch. Move switch towards above bracket until it actuates. Now tighten flat blade screws. Use a .040 thickness gauge to insert between bracket and switch and the switch should close and open again upon removal of thickness gauge.

Door cam check position

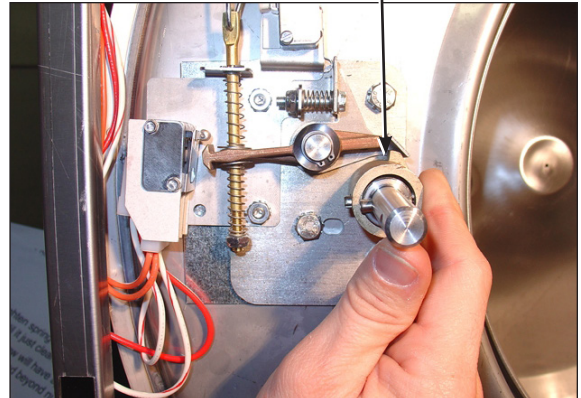

**Step 4:** Check for switch actuation at partial turn of cam as in operation above. Door handle goes from horizontal to six o'clock vertical.

Door lock rod      Locking pawl blocking

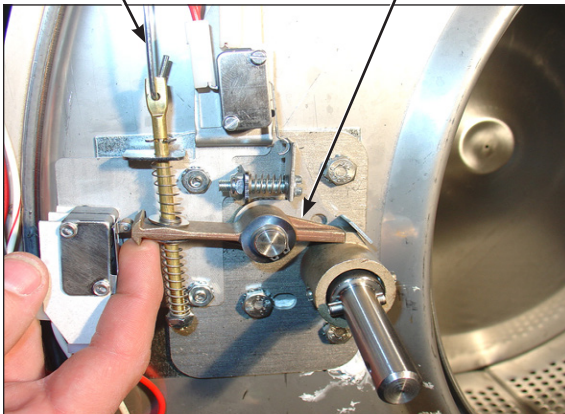

**Step 5:** Check that lock pawl arm swings to cam lobe to lock position.

Adjustment screw for (piggyback switches)

Top of flat end of locking pawl.

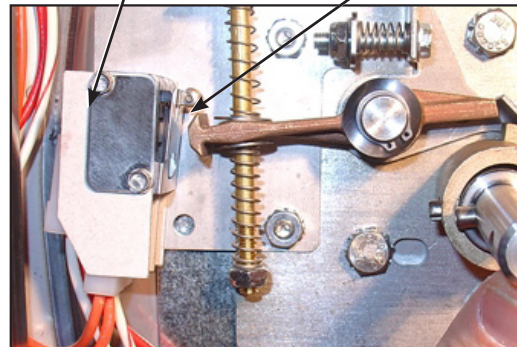

**Step 6:** The lock stacked switches (piggyback) must be adjusted as door lock solenoid pulls up on door rod and locking pawl is now blocking door cam from turning and is in full up position. The stacked switches (piggyback) have a single actuator arm and it must actuate when single actuator roller wheel rolls to flat side of locking pawl. You will also notice a .040 gap between actuator arm and switch bodies.

**Note: Both stacked switches must operate together!**

## Adjusting the Loading Door

The door can be adjusted by changing the number of shims behind the door hinge and the door lock assembly. The vertical fit of the door to the tub can be altered by loosening the door hinge bolts and raising or lowering the door before retightening. It is important for the door to be centered on the tub front. By chalking the front of the tub and closing the door to transfer that line to the gasket, the centering can be evaluated. It is also important for door pressure to be similar around the door perimeter. Door pressure can be evaluated by inserting a dollar bill in several positions and tugging on it. See Parts Section for kit to increase door sealing pressure.

### Loading Door Removal



**Step 1:** Support door to prevent dropping.



**Step 2:** Remove the bottom 2 bolts holding the lower leaf hinge and then remove it. The door can now be lifted from the upper post of the hinge assembly.

### Loading Door Hinge Removal

**Step 1:** First remove loading door and front panel.

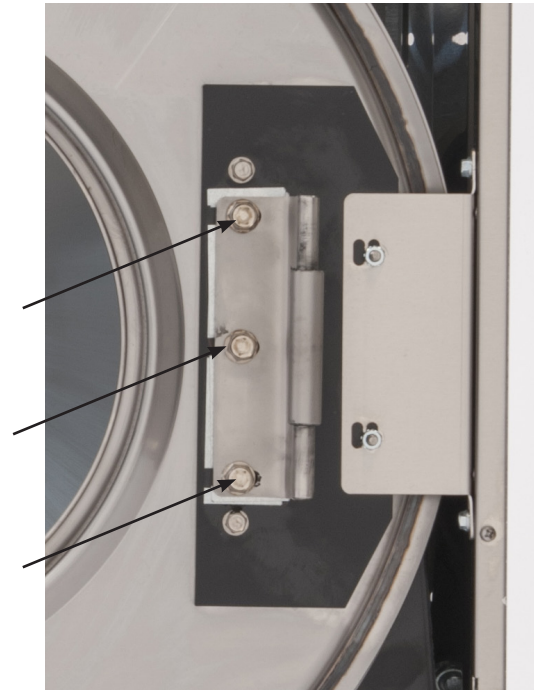

**Step 2:** Remove 3 screws holding door hinge. Shims may be present between hinge and tub front. The number may be increased or decreased to adjust right side door pressure.

**NOTE:**  
Door hinge mounting bolts penetrate tub front and require silicone sealer applied to holes when reinstalling.

---

## Loading Door Disassembly

- Step 1:** Remove the loading door as outlined above. Lay the door on a flat surface with the glass down.
- Step 2:** While holding down on the door glass, lift up on the door ring and roll back the lip of the gasket with your fingers.
- Step 3:** Work all the way around the gasket and the glass is out.

## Loading Door Reassembly

- Step 1:** Lay the door ring face down on a flat surface. Start the glass into one side of the door gasket.
- Step 2:** Use one hand underneath to push the gasket out and the other hand on the top pulling the gasket in place.
- Step 3:** The front lip of the door gasket should be checked for proper seating.

## Control Panel Name Plate Decal

The name plate on washer front is adhesive backed.

## Control Panel Name Plate Removal

The name plate may be removed by simply peeling it off.

## Re-Installation of Name Plate

- Step 1:** Remove any remaining glue from the control panel.
- Step 2:** Before removing the paper backing from the name plate, check fit to the control panel. The program push buttons are the locating guides.
- Step 3:** Remove the paper backing from the right side of the name plate, position it on the panel and press right end into place. Peel the backing from the left end and press into place.

## Bolt Torque Chart

T-750 Bolt Torque Chart		
Bolt Size	Where Used	Torque
1/2"x 1 1/4" bolt	Tub End of Bearing Hsing. 9545-017-009	70-110 ft/lbs
5/8"x 1 1/2" bolt	Tub End of Bearing Hsing. 9545-060-001	120-150 ft/lbs
1/2"x 1 1/4" bolt	Mtg. of Tub to Cradle Assy. 9545-017-009	70-110 ft/lbs
5/8"x 2 1/2" bolt	Mtg. of Tub to Cradle Assy. 9545-060-001	120-150 ft/lbs
3/8"x 1 1/2" bolt	Tub Back Ring to Tub Back 9545-029-003	45-80 ft/lbs

## Cylinder (Basket)

- Step 1:** Remove lower service panel as described previously.
- Step 2:** Remove front panel as described previously.
- Step 3:** Remove door lock assembly. (Leave wires & pull rod in place)
- Step 4:** Remove clothes door.
- Step 5:** Remove tub front clamp ring.
- Step 6:** Remove tub front. Use a flat screw driver to pry the tub front loose.
- Step 7:** Remove the rear access panel.
- Step 8:** Remove the drive belts.
- Step 9:** Remove drive pulley. Remove 3 retaining screws. Insert (3) 3/8 16 x 2" screws into the threaded removal holes. Alternately tighten these screws evenly to pull the pulley off.
- Step 10:** Remove pulley hub. Drive a flat screw driver into the slot in the hub and pull it from the shaft.
- Step 11:** Install cylinder puller. (Snap On part #CJ-84-C) Be sure to thread a 5/8-11 NC bolt into the end of the cylinder shaft to protect the threads. Push the basket out.

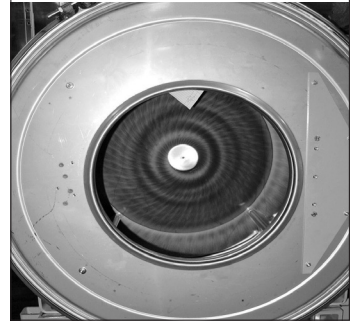

## Bearing Housing Assembly

### Removal

- Step 1: Remove cylinder from washer (see Cylinder (basket) removal).
- Step 2: Remove 6 7/16" tub back to bearing housing cap screws.
- Step 3: Remove 6 3/4" bearing housing to frame bolts.
- Step 4: Remove bearing housing from frame.
- Step 5: Remove the retaining ring next to the front bearing.
- Step 6: The bearings are pressed into the housing and must be pressed back out.

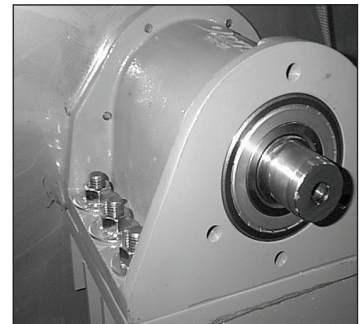

### Reassembly

- Step 1: When installing new bearings into a bearing housing, first press the front (large) bearing into the housing until it bottoms and install the snap ring. With the bearing spacer in place, press the rear bearing in until the spacer is snug between the two bearings.

**NOTE:** If the tub-back water-seal mating ring has been moved it must be cleaned and resealed

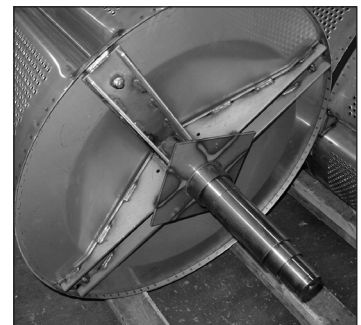

## Water Seals

### Replacement

- Step 1:** Remove cylinder from washer (see Cylinder (basket) removal).
- Step 2:** Remove water seals from the seal mounting plate on the cylinder shaft. These are removed with your fingers.
- Step 3:** The primary and secondary seals that mount on the sealing ring may be slid over the shaft and seated on the metal sealing ring with your fingers. In the unlikely event that the metal ring that mounts these sealing rings were to be damaged or moved, a new one would need to be pressed on. The seal mounting ring must be pushed against the stop on the shaft. After installing the seals, lubricate the faces of the seals with silicone grease.
- Step 4:** Install cylinder (see Cylinder (basket) reassembly).

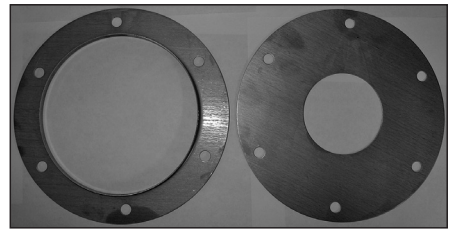

**Guard Ring & Mating Ring**

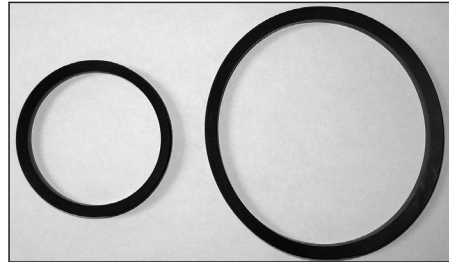

**Seals**

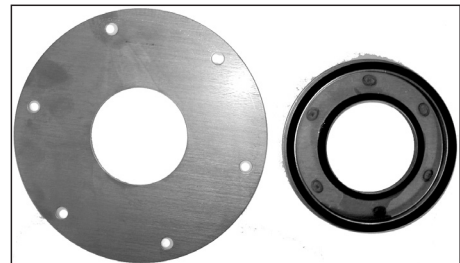

**Mating Ring & Mounting Ring**

## Outer tub

### Removal

- Step 1:** The outer tub can easily be removed when the tub front, cylinder and bearing housing has been removed as outlined previously.
- Step 2:** At that point the only attachments to the chassis are the two front strap mounting bolts.

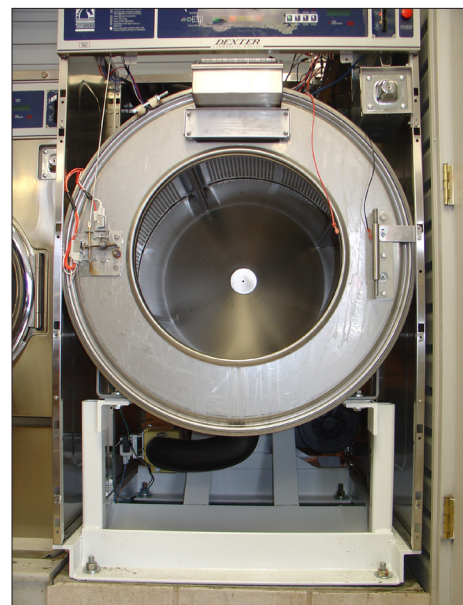

---

## Reassembly of the Cylinder

- Step 1:** Use the hub of the drive pulley, a stack of 5/8" flat washers and a 3" long 5/8" bolt to pull the cylinder shaft through the bearings. After the 3" bolt a 2" long bolt will be required to finish pulling the cylinder shaft through.
- Step 2:** Remove the 1/2" bolt and nut from the top of the outer tub clamping band.
- Step 3:** Install Dexter Tool part # 8545-056-001 on the back of the outer tub to adjust tub front to cylinder clearance. Thread 5/8" bolt through tool and into cylinder shaft. Push the outer tub forward 1/4" to 1/2" with tool 8545-056-001 by tightening the 5/8" bolt. This will ease the installation of the outer tub front.
- Step 4:** Clean the silicone rubber off the tub front and the outer tub.
- Step 5:** Install new bead of silicone rubber on tub front.
- Step 6:** Install tub front.
- Step 6A:** Align hole in top of tub front with notch in top of outer tub.
- Step 6B:** Use 4-6 #11R vise grip clamps to hold tub front to outer tub. A rubber mallet may be needed to properly seat the tub front into the outer tub.
- Step 6C:** Install tub front gasket around outer edge of tub front and outer tub flange. The opening should be centered at the top.
- Step 6D:** Remove vise grips. The tub front gasket will hold the tub front in place.
- Step 7:** Install tub front clamp ring and tighten. Tap around the clamp ring with a rubber mallet to seat the ring and gasket while tightening the clamp ring bolt.
- Step 8:** Adjust clearance between the outer tub front and the front lip of the cylinder to 5/16".
- Step 9:** Tighten the outer tub clamping band.
- Step 10:** If necessary, the outer tub may be adjusted up or down and side to side with the 2 bolts that fasten the bottom of the outer tub clamping band to the frame.
- Step 11:** Remove Dexter Tool part 8545-056-001 from the back of the outer tub.
- Step 12:** Install drive pulley.
- Step 12A:** Install hub on cylinder shaft.
- Step 12B:** Hold hub against rear bearing with 5/8" bolt and flat washer in end of cylinder shaft.
- Step 12C:** Line up 3 unthreaded holes in pulley with the 3 threaded holes in hub.
- Step 12D:** Insert 3 pulley bolts and tighten evenly alternating bolts to 30ft/lbs.
- NOTE:** Overtightening or uneven tightening can break drive pulley.
- Step 13:** Install drive belts & back panel.
- Step 14:** Install door lock. All mounting holes should be sealed with silicone rubber.
- Step 15:** Install door, front panel, lower service panel.

---

## Control Mounting Trough

Remove rear panel to access control trough. It sets on the left side of the machine and holds the control PCB's, transformers, and pressure switch.

## Main Data Communication Cable

Goes between front PCB board and Variable Frequency Drive unit mounted center rear of machine. It has telephone type connectors at each end and is inserted at Controller PCB and the Variable Frequency Drive.

## Circuit Breaker/Fuse

The fuse (optional circuit breaker) mounts to the rear channel. It carries all of the controls in the machine but does not include the motor. To reset the circuit breaker just push in the button. If you have a fuse then remove fuseholder and fuse and replace with a 1 1/2 amp fast blow type fuse.

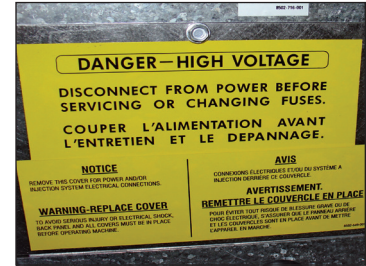

Fuse Location

## Main Control Printed Circuit Board

Please be sure to be grounded to machine before removal of this board from machine. PC board mounted vertically behind front control panel. Remove hold down nuts in 4 corners and 1 at bottom center.

## PCB Transformer Step-down

Small transformer mounted at front of control trough that is powered with 120 VAC primary and two secondary outputs of 24-27 VAC.

## Controls Transformer

This transformer is mounted at the back of the control trough and steps a range of 208 to 240 volts down to 120 volts for the controls. There are two terminals on the controls transformer for incoming power. One terminal tap is marked for 208 volts use this tap for measured voltage of 200 volts - 215 volts. And the other tap is marked 230 volts for 216 volts - 240 volts. **Note:** All washers have a controls transformer. Always check the incoming voltage and use the appropriate transformer terminal when installing ALL washers.

## Main Relay Printed Circuit Board

Please be sure to be grounded to machine before removal of this board. PCB mounting horizontal in control trough towards front of machine. Remove 4 mounting nuts.

## LED Printed Circuit Board Temperature & Start Display/Push-Button

The PCB is mounted in the center of the control panel and is held in place with five nuts. It allows the selection of hot, warm or cold water temperatures. **NOTE:** Do not over tighten on reinstallation as the PCB can be damaged, stay pushed in and will cause erratic displays.

---

## **Add-Bleach LED**

This LED light indicates to the user the correct time to add bleach. This LED is polarity sensitive and must be connected correctly.

## **Power Connection Terminal Block**

This terminal block sets at the very back of the control trough. Incoming power to the washer should connect here. (See Electrical under Installation and Operation Section for exact connections)

## Electronic Pressure Sensor

The Electronic Pressure Sensor comes standard on all models Starting September, 1st 2015. Machines manufactured before this date can be upgraded with Kit 9732-213-001. The Pressure sensor is adjustable. The Factory settings chart will let you know the starting values for each machine and by following the Switch position chart you can adjust the water levels in 1/4 inch increments from that starting value.

### Factory Settings:



Model	Vended		On-Premise	
	Switch #1 Efficient	Switch #2 Classic	Switch #1 Low Level	Switch #2 High Level
T-300	5.25	7.00	6.00	6.75
T-350	5.25	6.25	6.00	6.75
T-400	7.00	9.00	8.00	11.00
T-450	6.00	6.25	6.00	8.50
T-450 SWD	5.00	7.00	6.00	8.50
T-600	7.25	9.25	8.00	11.00
T-650	6.50	8.25	8.00	11.00
T-750	6.00	7.50	6.00	8.75
T-900	6.00	7.50	6.00	8.75
T-950	6.00	7.50	6.00	8.75
T-1200	6.00	7.50	6.00	8.75
T-1450	6.75	7.00	6.75	9.50

### Switch Positions:

Depth (in):	Pos 1	Pos 2	Pos 3	Pos 4	Pos 5	Pos 6
5.00						
5.25	on					
5.50		on				
5.75	on	on				
6.00			on			
6.25	on		on			
6.50		on	on			
6.75	on	on	on			
7.00				on		
7.25	on			on		
7.50		on		on		
7.75	on	on		on		
8.00			on	on		
8.25	on		on	on		
8.50		on	on	on		
8.75	on	on	on	on		
9.00					on	
9.25	on				on	
9.50		on			on	
9.75	on	on			on	
10.00			on		on	
10.25	on		on		on	
10.50		on	on		on	
10.75	on	on	on		on	
11.00				on	on	
11.25	on			on	on	
11.50		on		on	on	
11.75	on	on		on	on	
12.00			on	on	on	
12.25	on		on	on	on	
12.50		on	on	on	on	
12.75	on	on	on	on	on	
13.00						on
13.25	on					on
13.50		on				on
13.75	on	on				on
14.00			on			on
14.25	on		on			on
14.50		on	on			on
14.75	on	on	on			on
15.00				on		on

---

## **Delta Variable Frequency Drive:**

Main power is connected to terminals L1, L2, and L3 on the Delta drive. If the washer is connected to a three phase source, there should be voltage present on all three terminals. If the washer is connected to single phase power, there should be voltage present on terminals.

The voltage should measure 208 Volts to 240 Volts A.C. between phases and connected to if connected to three phase). There is a tolerance of + 10% on the mains voltage (187 Volts to 264 Volts).

## **Delta VFD Motor Leads:**

The wires from the motor are connected to terminals T1, T2, and T3. Since this drive uses pulse width modulation, an accurate current or voltage reading is not possible. Although an accurate current reading is not possible, a balanced current reading should be present while the motor is running.

## **Delta VFD Dynamic Braking Resistors:**

Two 200 Ohm braking resistors are connected in parallel and attached to the drive at terminals B1 and B2. These resistors allow voltage, which is generated by the motor when decelerating, to be dissipated. They will become hot while the motor is slowing down, so care should be taken so as not to come in contact with them. This will prevent an electrical shock and/or a physical burn.

## **Delta VFD Cooling Fan:**

There is a cooling fan attached to the bottom of the Delta drive. This fan will operate when the internal temperature of the drive reaches a predetermined level, the same way the radiator fan in a newer car operates. THE FAN CAN OPERATE ANYTIME POWER IS APPLIED TO THE DRIVE! Remove power to the drive if work is required around the fan.

# Common Washer Troubleshooting Solutions

Symptom	Probable Cause	Suggested Remedy
Machine does not start	Power Supply	Check these areas: Circuit breakers, Voltage, Power leads, Power connections. Is front display LED showing a dollar amount.
	Door Switch	Check for continuity through door switch when door is closed. If no continuity, adjust or replace door switch.
	Control Breaker or Fuse	Check 1.5 amp breaker or fuse for continuity. If no continuity, replace breaker or fuse.
	Control Transformer	Check voltage output from control transformer for 120VAC. If voltage is incorrect, replace transformer.
	Check PCB board	Check all wire connections for sure contacts.
	Check Wiring Between PCB	Check data cable phone type connectors unplug and VFD and replug with power removed.
	Check Relay PCB	Check all wire connections for sure contact.
	Check Door Gear Motor	Check that 120 v power is at solenoid after start button is pushed.
Machine will not accept and count coins	Power Supply	Check these areas: Circuit breakers, Voltage, Power leads, Power connection
	Door Closed Safety Switch	Check door closed switch at door hinge for proper operation.
	Door Handle Closed Switch	Check single door closed switch at left side of door handle to close when handle is vertical.
	Control Breaker Or Fuse	Check 1.5 amp (T-1200 uses 2.5 amp) breaker or fuse for continuity. If no continuity, replace breaker.
	Main PCB	Replace
Door does not lock	Check Display For Fault Code	Does F1 show on the front of display. If yes follow tests described in fault code section.
	Door Locking Gear Motor	Check to insure that solenoid is receiving 120VAC from main relay PCB. If it is, replace solenoid.
	Door Switch	Check for continuity through door latch switch when door closed. If no continuity, adjust or replace door switch.
Door will not open	Thermoactuator	Check to see if thermoactuator(s) and/or its mechanism is stuck or binding and not allowing the door lock solenoid to open. Check to be sure that the locking thermoactuator is not receiving 120VAC during the last 1 1/2 minutes of the cycle. Also check to see that the unlocking thermoactuator is receiving 120VAC during the last minute of the cycle. If the thermoactuators do not receive voltage at the correct times, change the timer. If the timing and voltage are correct, replace the thermoactuator.

Symptom	Probable Cause	Suggested Remedy
Door will not open	Door Rod	Check to see that door rod from Gear Motor to lock ass'y is long enough to allow lock ass'y to disengage. If not, adjust rod.
	Door Lock Solenoid	Check that door lock Gear Motor is not stuck closed. If stuck, replace solenoid.
No hot water in detergent dispenser	Water Valve Coil	Check coil continuity at terminals and replace if no continuity. 120 V power only on for 20 second in wash bath.
	Water Inlet	Check water inlet screens for blockage and clean screens if necessary.
	Water	Check to insure that water is turned on and operating.
	P-20 Wire Harness	Check black & white harness.
Hot water does not enter tub in wash	Water Valve Coil	Check coil continuity at terminals and replace if no continuity. Check for 120 V power from main relay PCB
	Water Inlet	Check water inlet screens for blockage and clean if necessary screens
	Water	Check to insure that water is turned on and operating.
	Blk or Wht Wire at Main Controller	Check black or white wires at Molex plug on PCB at main controller and at relay PCB.
	Pressure Switch	Check pressure switch continuity between terminals . If no continuity, check pressure switch hose for obstruction. If hose okay, change pressure switch.
No cold water to tub in wash	Water Valve Coil	Check coil continuity at terminals and replace if no continuity.
	Water Inlet Screens	Check water inlet screens for blockage and clean if necessary.
	Water	Check to insure that water is turned on and operating.
	Blk or White Wire at Controller and Main Relay PCB	Check black or white wires at Molex plug on PCB at main controller and at relay PCB.
	Pressure Switch	Check pressure switch continuity between terminal contacts. If no continuity, check pressure switch hose for obstruction. If hose okay, change pressure switch.
Water comes in but level does not rise	Drain Valve (open)	Check these areas • Drain valve blockage • Drain valve motor and gear train. If power but drain valve does not close, replace valve. • Power to the drain valve. If no power to drain valve, check (brn/yel) circuit for power.
	Blk or White Wire at Controller	Check black and white wires at molex plug on main PCB controller and at main relay PCB
Water does not flush softener compartment.	Water Valve Coil	Check coil continuity at terminals and replace if no continuity.
	Water Inlet Screens	Check water inlet screens for blockage and clean if necessary.
	Water	Check to insure that water is turned on and operating.

# Common Washer Troubleshooting Solutions

Symptom	Probable Cause	Suggested Remedy
Water does not flush softener compartment.	Pressure Switch	Check pressure switch continuity between terminals. If no continuity, check pressure switch hose for obstruction. If hose okay, change pressure switch.
Water level too high	Pressure Switch	Check for blockage in pressure switch hose. Check for pressure switch opening circuit across terminals. Replace switch if contacts do not open.
Water drains slowly	Drain System	Check hoses and drain valve for blockage. Clean of inadequate size, if necessary. Check building drains for blockage
Machine does not turn	VFD	Check VFD by removing inspection panel and record any numbers or letters displayed. If no display turn power off to machine at breaker for 2 minutes and turn power back on to reset. If still no display replace VFD
Machine tumbles in one direction	VFD	Remove inspection cover at rear and record in only numbers or letters displayed. See fault code section for more info.
	VFD	Inspect yellow enable wires from main relay PCB and at VFD
Excessive vibration	Mounting System	Check these areas: • Strength of mounting structure, concrete or base. • Mounting bolts may be loose and need tightening.
	Drive Belt	Worn drive belt can cause vibration and noise.
	Loading	<b>Note:</b> Small loads contribute to out of balance loading and increase vibration.
Machine does not spin	Pressure Switch	Check pressure switch for continuity across terminals #21 & #22 indicating pressure switch has reset to the empty position. If no continuity, change pressure switch.
Machine starts and does not operate	VFD	Check yellow enable wires from relay PCB P13 & motor P14 to VFD advances through cycle are connected. Check fault code on VFD before removing power from the drive. Check orange P-15 wire for signal from door switches.
Machine does not stop	Main PCB	Main PCB controls time cycle at end of cycle
	Braking Resistors	Check braking resistors for continuity. Verify ohms resistance by Molex.
Water leakage around loading door	Door Adjustment	Door may need adjustment due to abuse or wear. Check tightness around perimeter using a dollar bill. Adjust left to right tightness by shims at door lock or hinge side. It is important to center gasket to tub opening before tightening door to hinge bolts. Chalk may be used on tub front to show point of contact with tub. If gasket is deformed, worn, or damaged, replace. Refer to parts section for door gasket expander kit.

# Troubleshooting Machine Fault Errors

Displayed on front of washer

The following are descriptions of fault codes that will appear on the front of the washer. There is a chart format that shows what fault code that will be displayed at washer front. The codes displayed may or may not stop machine operation.  
PLEASE NOTE: CHECK DRIVE FAULT CODE BEFORE POWERING MACHINE DOWN!

Fault#	Description	Customer Action
<b>F1</b>	The door failed to close and lock or The door failed to remain locked during the cycle.	Check VFD fault code before turning off. Check to hear if door solenoid engaged. Turn off the power to the washer. Check wire connections to door /lock switches. Check wire connections from switches to controller. Check P-4 wire connections at PCB controller. Adjust the door lock mechanism. (See service manual)
<b>F2</b>	The washer tub does not fill with water within 7 minutes. The wash cycle will continue. The F 2 will flash three times, then wait for 30 seconds. The error will clear at the end of the cycle.	Turn off the power to the washer. Check the operation of the water valves. Check the incoming water pressure. Check for blocked or restricted water flow. Check to ensure the drain valve is functioning properly. This error will occur on 18# washers when water level is set for high (the pressure switch in 18# washer is only one level).
<b>F3</b>	Memory error in controller. The memory checksum is wrong.	Check VFD fault code before turning off power. Try to clear the fault with the Palm. Try a soft Reset of the controller with the white button. If problem. Replace PCB controller.
<b>F4</b>	Washer controller communication error	Check VFD fault code before turning off power. Try the data cable first. Move around cable and remove any side loading tension from data cable connector ends. Check connection P25/24/23 to P15. Turn power back on to the washer. If the problem returns, replace the PCB washer controller.
<b>F5</b>	Pressure Switch error (only OPL) - when the high level sensor indicates full but the lower one indicates empty. The wash cycle will continue. The F 5 will flash three times, then wait for 30 seconds. The error will clear at the end of the cycle.	Check VFD fault code before turning off power. Check the pressure switch.(Ohm out contacts). Check pressure switch connections to ensure they are all making good contact. Check the Molex type harness connector to ensure no wire been pushed out of the Molex type housing that it is shorting or not connecting.
<b>F6</b>	Wrong washer size for drive type.	Check VFD fault code before turning off power. If the controller was installed in a different size machine before being installed in this machine, a problem can occur. If someone has been doing repairs on the washer, check for the correct size drive. It can also be caused by pressure switch harness. Check to ensure the correct harness in installed. The control can be reset by holding program button on controller during startup (soft reset). Check orange wire at Molex connector on controller coming from pressure switch or replace pressure switch harness.

<b>Fault#</b>	<b>Description</b>	<b>Customer Action</b>
<b>F7</b>	Wrong size drive installed	Check VFD fault code before turning off power. Check to ensure all the harnesses are properly connected to the controller. Check to ensure the VFD drive horsepower is proper for this size of washer. The control can be reset by holding program button on controller during startup (soft reset) Check orange wires at molex connector on controller coming from pressure switch.
<b>F8</b>	The washer tub does not empty within 7 minutes. The wash cycle will continue. The F 8 will flash three times, then wait for 30 seconds. The error will clear at the end of the cycle.	Check VFD fault code before turning off power. Check to ensure the drain valve is operating properly (slow drain has potential to cause this code). Check to ensure the pressure switch tube is clear of any blockage, and the pressure switch is operating properly. Check the pressure switch harness.
<b>F9</b>	The washer tub does not reach the spin target frequency within 150 seconds. The wash cycle will continue. The F9 will flash three times, then wait for 30 seconds. The error will clear at the end of the cycle.	Check VFD fault code before turning off power. Check to ensure the drain valve is operating properly (slow drain has potential to cause this code). Check to ensure the pressure switch tube is clear of any blockage, and the pressure switch is operating properly. Check the pressure switch harness.
<b>F10</b>	After a spin the washer tub does not stop within 150 seconds.	Check VFD fault code before turning off power. Inspect the braking resistors and measure the resistance. Check connecting wiring from braking resistor to the drive mounted in the top of the washer. Reset the drive and try again. Possibly incorrectly programmed drive.
<b>F11</b>	The drive size setting has changed.	Check VFD fault code before turning off power. Check to ensure all the harnesses are properly connected to the controller. Check to ensure the drive horsepower is proper for this size of washer. If no one has worked on machine very recently then PCB controller or VFD may need to be replaced. Do a soft reset before and after either VFD replaced.
<b>F12</b>	Washer controller internal error	Check VFD fault code before turning off power. Turn off the power to the washer. Wait one to two minute. Turn on the power to the washer. If problem reappears, contact your Dexter Authorized Representative.

Fault#	Description	Customer Action
<b>F13</b>	The variable frequency drive (VFD) and the washer computer are not communicating.	<p>Check the data communication cable between the washer computer and the variable frequency drive (VFD).</p> <p><b>Step 1:</b> Make sure the cable did not become unplugged during operation.</p> <p><b>Step 2:</b> Make sure that the cable is not being pulled sideways at either the washer controller, or the VFD, plug end. If both ends of the communications cable are plugged in the washer computer and VFD and there is no tension on the communications cable pulling it from side to side, then replace the cable.</p> <p><b>Step 3:</b> Inspect both female connection points at PCB controller and at VFD. These may need replacement if they cannot be reset.</p>
<b>F14</b>	Over-current on the drive or motor.	<p><b>Step 1:</b> Check to make sure the washer cylinder turns freely by hand. If it turns freely, continue to step 2. If it does not, remove the belt and see if the motor turns freely by hand. If the motor turns freely, then check for obstructions in the cylinder or check the bearings. If the motor does not turn freely, replace the motor.</p> <p><b>Step 2:</b> Check the motor wires for a short circuit between leads. If there are motor leads that have conductors touching, separate them and insulate them. If the wires are broken, splice them together or replace the motor.</p> <p><b>Step 3:</b> Check braking resistors to see if they measure the correct resistance. If a resistor does not measure the proper value, replace it.</p>
<b>F15</b>	The variable frequency drive (VFD) senses that the internal voltage is too high. The source of the problem can originate from two different areas. Area 1: The input voltage can be too high, or there may be a high level of electrical noise. Area 2: The motor can be generating a voltage that is acting like an input to the VFD output motor terminals.	<p><b>Step 1:</b> Measure the supply voltage to the VFD on the L1, L2 (or N), and L3 (if connected to three phase power). the supply voltage should be from 187 to 264 VAC or 108 to 132 VAC for a 120 VAC VFD. Also make sure the supply wires on L1, L2 (or N) and L3 (if connected to three phase power are securely connected.</p> <p><b>Step 2:</b> Check the braking resistor connections at the VFD. The terminal screws should be tight. Once of the braking resistor wires should be connected to terminal B2.</p> <p><b>Step 3:</b> Measure each braking resistor separately to make sure they are the correct resistance. (200 for 1 and 2 Hp VFD and 160 for 3 Hp VFD).</p> <p><b>Step 4:</b> If you have a 240 VAC, high leg voltage supply, try disconnecting the high leg. If this cures the problem, either leave the high leg disconnected, connect a transient voltage surge suppressor (with some form of filtering) at the voltage supply panel, connect a line choke on the high leg or install a VFD filter.</p>

<b>Fault#</b>	<b>Description</b>	<b>Customer Action</b>
<b>F16</b>	The temperature sensor inside of the variable frequency drive detects that the internal temperature is too high.	<b>Step 1:</b> Make sure the cooling fins on the VFD heatsink and the ventilation louvers on the VFD cooling fan cover are clean. <b>Step 2:</b> Start a washer cycle and make sure the VFD cooling fan operates after the cylinder starts turning.
<b>F17</b>	Overload of the drive or motor	(Check drive fault code before powering down). Check the washer motor to ensure it turns freely. Check the wiring for loose connections to the drive and motor. Measure the braking resistor values. Check for damaged motor wires. Check V-Belt tension and adjust to 1" deflection at center. Check braking resistors.
<b>F18</b>	Ground Fault to the drive	Check VFD fault code before turning off power. Check the wiring connections to the drive and motor. Check the ground wiring of the drive, motor and incoming connection to ensure a proper ground is present. Check for damaged motor wires.
<b>F19</b>	Low Voltage to the drive	Check VFD fault code before turning off power. Turn the power off to the washer. Check the wiring connections to the drive and motor. If no problem is observed, turn on power to the washer and test. (See Note) Measure the incoming line voltage.
<b>F20</b>	Internal drive error	Check VFD fault code before turning off power. Turn the power off to the washer. Wait one minute. Turn the power on to the washer. If problem reappears, contact your Dexter representative.
<b>F21</b>	Data error on communications between the controller and drive Internal drive error # 32. This error also has CEXX errors associated with it that are presented on the drive display.	The CE errors are communications errors. Data Cable noise can cause the majority of these errors. Check VFD fault code before turning off power. Check the data cable between the controller and the drive. Replace data cable if it appears damaged and fault appears again. Please note that this fault will occur if you turned main power off and on to quickly. (See Note below)

**Warning codes F22 - F28: These codes indicate that a component (VFD, relay PCB, injection relay PCB, water valve) has been replaced, added, or removed and you will need to soft reset the PCB controller board to reset the main controller to operate properly.**

<b>Fault#</b>	<b>Description</b>	<b>Customer Action</b>
<b>F22</b>	MS300 Drive Conversion Only	Retighten the screw down connections on the lower terminal bar of the VFD for DC1, B1, and B2. Check the wire connections on B1 and B2 for Breaking Resistors.
<b>F23</b>	VFD has been replaced, disconnected, or removed.	Soft reset control.
<b>F24</b>	Injection relay PCB has been removed or loose connection.	Soft reset control.
<b>F25</b>	Optional water valve PCB removed or water valve has been replaced .	Soft reset control.

<b>F26</b>	VFD unit has been added or loose connection.	Soft reset control.
<b>F27</b>	Injection relay PCB has been added to machine or loose connection.	Soft reset control.
<b>F28</b>	Optional water valve PCB has been added or loose connection	Soft reset control.
<p><b>NOTE:</b> Whenever power is turned off to the washer, it must remain off for three minutes for drive to reset. The washer will not operate correctly if this is done improperly. This will allow most fault codes to reset that are displayed at washer front. A fault code F-13 or F-21 will appear on front display if this procedure has not been reset correctly. Note: Should a power loss occur during cycle and then power returns, P U S H will be displayed and customer must push a temperature selection button to continue the cycle.</p>		

## Drive Motor Inverter Type Motor-Winding Resistance Chart

### T-750 C-Series Express Washer

<b>Motor</b>	<b>Winding</b>	<b>Wire #</b>	<b>Resistance</b>	
			<b>Minimum</b>	<b>Maximum</b>
T-750 1ph or 3ph 60hzMain (wash & spin)		T1 & T2	.944	1.097
Dexter #9376-329-001		T2 & T3	.944	1.097
Marathon #		T1 & T3	.944	1.097

# Variable Frequency Drive Control

## Digital Readout Faults

Fault#	Description	Customer Action
<b>CE1</b>	VFD received an illegal command. Possible controller problem	Reset drive.
<b>CE2</b>	Illegal data address, VFD received an address not available to the controller.	Reset drive.
<b>CE3</b>	Illegal data value received at VFD. Possible controller problem.	Reset drive.
<b>CE4</b>	VFD unable to perform the requested action. Possible controller problem.	Reset drive.
<b>CE6</b>	Time frame between commands is too short. Possible controller problem.	Reset drive.
<b>CE9</b>	Internal checksum error. VFD problem.	Reset drive.
<b>CE10</b>	Watch dog timer. Command not received from the controller every 6 seconds	Reset drive.
<b>CE11</b>	Frame error. Possible Baud rate issues between VFD and controller	Reset drive.
<b>CE12</b>	Command message is too short. Possible controller problem	Reset drive.
<b>CE13</b>	Command message is too long. Possible controller problem	Reset drive.
<b>CE14</b>	Command message includes unused characters. Possible controller problem.	Reset drive.

Normal operation of the VFD: VFD display shows operating frequency first very quickly then changes to F0.0 at time power is returned. This will stay displayed until the VFD receives a command from main control PCB. (Pushing start button) A CE-10 fault will display at drive if improper communication between PCB and VFD has occurred.

**NOTE:** Resetting a fault code on front of washer: Turn the power off to machine (machine will need to remain off for up to three minutes ).

SOFT RESET : is accomplished by pushing the white button located on the Main controller PCB board and simultaneously turning power on to machine. This will reset main controller to factory default settings.

Please record any modified information that has been inserted in memory before attempting to Soft Reset the PCB.

CE5, CE7 and CE8—Reserved by DELTA

---

## Variable Frequency Drive Control

### Digital Readout Faults

<b>Fault#</b>	<b>Description</b>	<b>Customer Action</b>
<b>OL or OU</b>	Overload of the drive or motor	(Check drive fault code before powering down). Check the washer motor to ensure it turns freely. Check the wiring for loose connections to the drive and motor. Measure the braking resistor values. Check for damaged motor wires. Check V-Belt tension and adjust to 1" deflection at center. Check braking resistors.
<b>GF</b>	Ground Fault to the drive	Check VFD fault code before turning off power. Check the wiring connections to the drive and motor. Check the ground wiring of the drive, motor and incoming connection to ensure a proper ground is present. Check for damaged motor wires.
<b>LU</b>	Low Voltage to the drive	Check VFD fault code before turning off power. Turn the power off to the washer. Check the wiring connections to the drive and motor. If no problem is observed, turn on power to the washer and test. (See Note) Measure the incoming line voltage.

---

# **Section: 9**

Washer Electrical  
Wiring Diagrams &  
Schematics

---

# Electrical Path Circuit Schematics

## Start Circuit

Power travels into the machine on L1 & L2 & (L3, if 3 phase used). L1 and L2 provide 208- 240VAC to the controls transformer which steps the voltage down to 120VAC for the controls. (The L1 connection at the controls transformer must be checked at start-up to coincide with machine operating voltage) The 120VAC travels out from the transformer on either [X-1 red wire directly to the 1.5 amp fuse] or [X-1 black/red wire to TB-4 and then through the red wire to the 1.5 amp fuse]. The controls transformer also creates a neutral on the X-2 black/blue wire that connects to TB-1. From the fuse holder, 120VAC travels on the red wire to the #6 terminal on the terminal strip and then through the black wire to another step-down transformer. From the terminal strip the blue wire will provide the neutral for gear motor, thermoactuators and all valves. The white wire provides the neutral from the terminal to the step down transformer.

120VAC is stepped down to 2.3VAC (blue wires), 24VAC (red wires), and a yellow center tap wire to the P-7 power connection on the main controller PCB . With the main control PCB now powered, 5VDC will be present between the (2) yellow wires and also the (2) brown wires for the coin switches. Both pairs will now be ready to count coins through the P-2 connection at the control PCB. 26.8 VAC goes out on the black wire of the P-4 connection from the main control PCB to the S5 door closed switch which mounted on the hinge side of masking ring. Closing the door will engage the door closed switches, sending the voltage to the red wire on the S1 door latched switch. Turning the door handle to the vertical latched position closes the S1 door latched switch, returning the voltage to the main control PCB on the white/red wire at the P-4 connection. 26.8VAC is now present at the S2 and S3 door locked switches.

26.8VDC is also at the black and white wires between P-21 at the main control PCB and the P-20 of the relay PCB. This voltage signals the relay PCB that the door is closed and latched making 120VAC available to the relays controlling the door lock gear motor, drain valve, and water valves. A continuous 5VDC is sent on the red wire from the P-1 connector on the main control PCB, through the (normally closed) emergency stop button switch and returns on the second red wire back to the P-1 connector. Payment is added and the display counts down on the main control PCB display until the vend price is satisfied. The display will change to read PUSH and the green light over the start button will flash. Pressing the start button on the front of the main control PCB signals the relay PCB to lock the door and 120VAC will go to the door lock solenoid on the white/red wire from the P17 connector of the relay PCB. The door lock solenoid engages and pulls up on the door locking rod, locking the door and closing the S2 and S3 door locking switches.

The S2 locking switch is a backup to the S1 latching switch so that once the cycle starts the S1 isn't critical. The S3 locking switch provides 26.8VDC on the orange wire back to P4 connector at the main control PCB and the P15 connector at the relay PCB. This signals that the loading door is closed,locked and safe to continue wash operations. This activates the P-13 and P-14 yellow enable wires to the inverter drive to allow motion. If there is no signal on P-15 (orange wire) there will be no motion of the tub. S1, S2, S3 and S5 door switches are now closed . The green On LED and the door lock solenoid (discussed in start circuit) will remain on throughout the cycle.

## Fill Circuit-Warm

The relay PCB supplies 120VAC to the brown/yellow wire from P-17 to the drain valve which closes the valve. The lock thermoactuator also receives 120VAC on orange/blue from P17 of the relay PCB. This device prevents the door lock gear motor from dropping out and unlocking during the cycle in the event of a power loss. The 120VAC will cycle on and off keeping the lock thermoactuator engaged until 70 seconds before the end of the cycle. The main control PCB sends data commands to the VFD through the data cable connected at P-6. These commands control the wash basket which will tumble one direction for 12 seconds, pause, and then reverse direction for 12 seconds.

The prewash or wash LED will illuminate at this time, powered through the white wires from the P-3 con-

---

nection of the main control PCB to the LED printed circuit board. Using the factory preset cycle as an example: The washer fills the tub through the back of the machine with either one or both the C1 cold and H1 hot water valves. From the P19 connection of main relay PCB, 120VAC is sent out on the white/brown wire to the C1 cold water fill valve and the red/yellow wire to the H1 hot water fill valve depending on the temperature selected. After a 90 second delay from the beginning of the wash cycle bath only, the detergent dispenser flushes the detergent into the tub for 20 seconds. This is accomplished when 120VAC travels through the red/orange wire to the H2 hot water valve solenoid. During the machine fill, a 5VDC signal is sent on the red wire from the P5 connection of the main control PCB to the pressure switch contact and returns on the yellow and orange wires to the P5 connection of the main control PCB. When the water level in the basket reaches the preset level pressure, the switch moves the switch contacts to the full or open position. This causes the main control PCB to signal the relay PCB to shut off the water valve coils.

## Wash Circuit

Once the machine has achieved it's water level, the wash basket will continue to tumble one direction for 12 seconds, pause, and then reverse direction for 12 seconds. The time on the front display will count down as the bath progresses. The time of the bath is programmable up 15 minutes per bath.

**NOTE:** When programming cycles, the wash bath must be programmed for 3 minutes or more.

## Drain

When the program bath time ends the main control PCB signals the relay PCB to remove 120 VAC power from brown/yellow wire at P17 going to the drain valve. The normally-open, spring-loaded drain valve opens allowing water to exit the machine. This resets the pressure switch back to an empty level and restores the 5VDC connection through the pressure switch from the red wires to the orange and yellow wires.

## Rinse 1 & 2

For Rinse 1 & 2,3,4, the rinse LED will illuminate, the drain valve will receive 120VAC and close. The basket will fill and tumble the same as the wash bath for the programmed time. The rinse water temperatures are programmable and factory default is cold.

## Final Rinse Circuit

The final rinse LED will illuminate, the drain valve will receive 120VAC and close. The basket will fill and tumble the same as the previous baths for the programmed time. The final rinse water temperatures are programmable.

**NOTE:** When programming cycles, the final rinse bath must be programmed and cannot be set for less than 3 minutes. Also at the beginning of the final rinse bath, the main control PCB will signal the relay PCB to send 120V to the P-19 connector on the white/blue wire to the C2 cold water valve for 20 seconds to flush the fabric softener dispenser.

## Spin Circuit

The spin LED will illuminate and the main control PCB sends a signal to the variable frequency drive via the data cable at P6 to VFD RJ-11. The rotation as viewed from front during spin will be counter-clockwise. (The 18lb washers will extract in a clockwise direction) The time of the spin cycle can be programmed.

Note: The final spin must be programmed into the final rinse bath and must be programmed for 1 minute or more.

---

## Unlock Thermoactuator and Shake Out Circuit

70 seconds before the end of the cycle the main control PCB signals the relay PCB to remove 120VAC from the orange/blue wire at the P-17 connector on the lock thermoactuator. This allows the lock thermoactuator time to cool and retract by the end of the cycle. To insure that the lock thermoactuator has retracted by the end of the cycle, 1 minute prior the end of the cycle, the unlock thermoactuator is powered with 120VAC through the orange/red wire from the P-17 connector of relay PCB. The unlock thermoactuator moves the complete bracket assembly away from the white door lock actuator allowing it to drop at the end of the cycle, unlocking the door. The basket will come to a stop from spin speed with the assistance of dynamic braking resistors wired to the variable frequency drive. (See wiring diagrams for quantities and resistor ohm values). The washer will then tumble for 45 seconds to let the clothes shake loose from the basket and then stop.

## End of Cycle and Door Open Circuit

Once the machine stopped, 3 things occur:

1. The enunciator will signal for 3 seconds letting the user know that it is the end of the cycle.
2. The Display of the Washer will scroll "CYCLE DONE THANK YOU".
3. The main control PCB signals the relay PCB to remove power from the white/red wire at P-17 which allows the door lock solenoid to unlock. When the loading door is opened, the S1,S2,S3,S5 switches are opened. The machine is now ready to accept coins again.

# Vended Drive Motor Inverter Type Motor-Winding Resistance Chart

## T-750 C-Series Express Washer

Motor	Winding	Wire #	Resistance	
			Minimum	Maximum
T-750 1ph or 3ph 60hzMain (wash & spin)		T1 & T2	.944	1.097
Dexter #9376-329-001		T2 & T3	.944	1.097
Marathon #		T1 & T3	.944	1.097

**NOTE:** Resistance values are measured at the stator. Values at the end of the motor wiring harness may be slightly higher.



# Wiring Schematic for 60hz OPL Washer

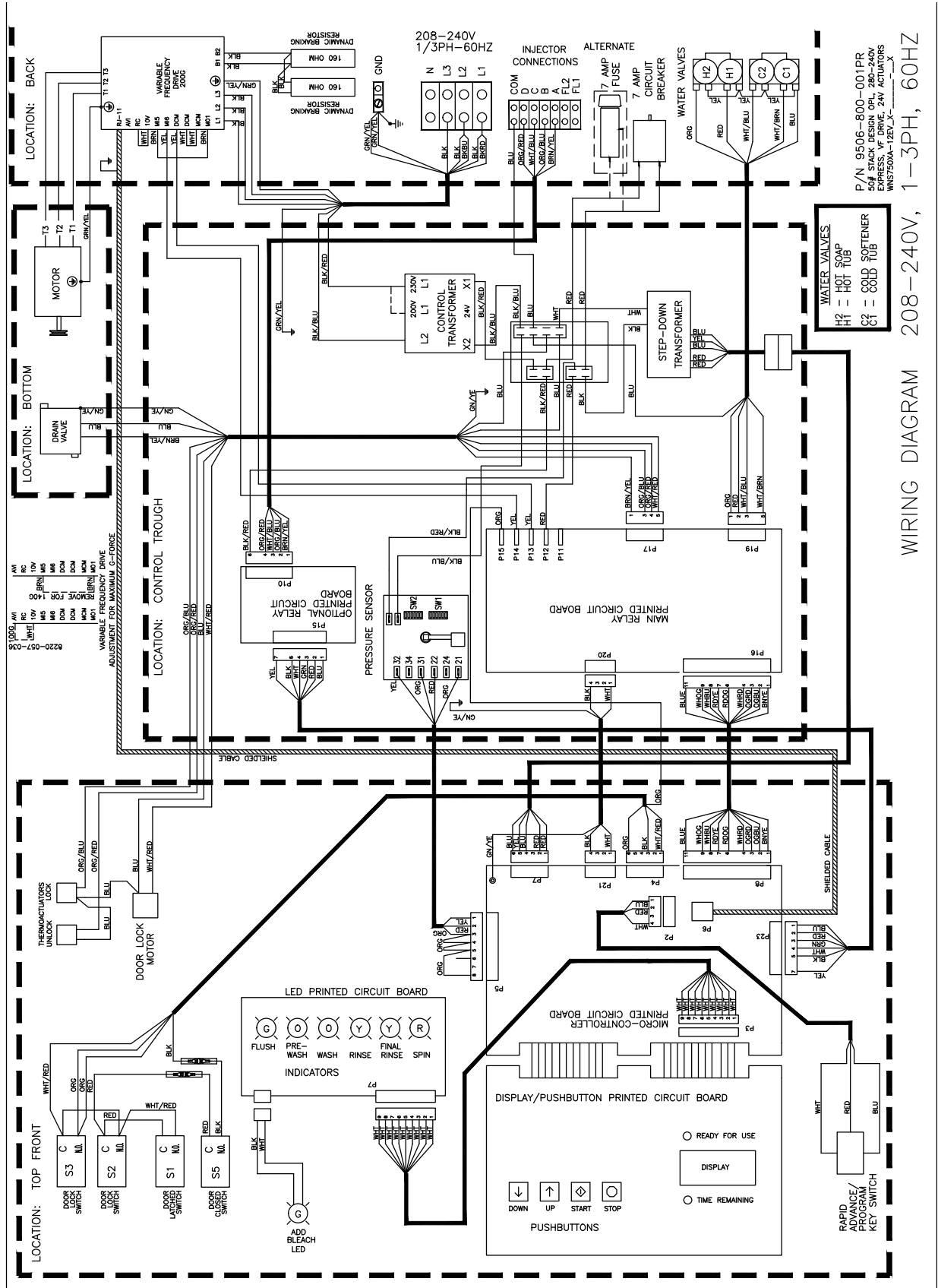

# Wiring Diagram for 60hz OPL Washer

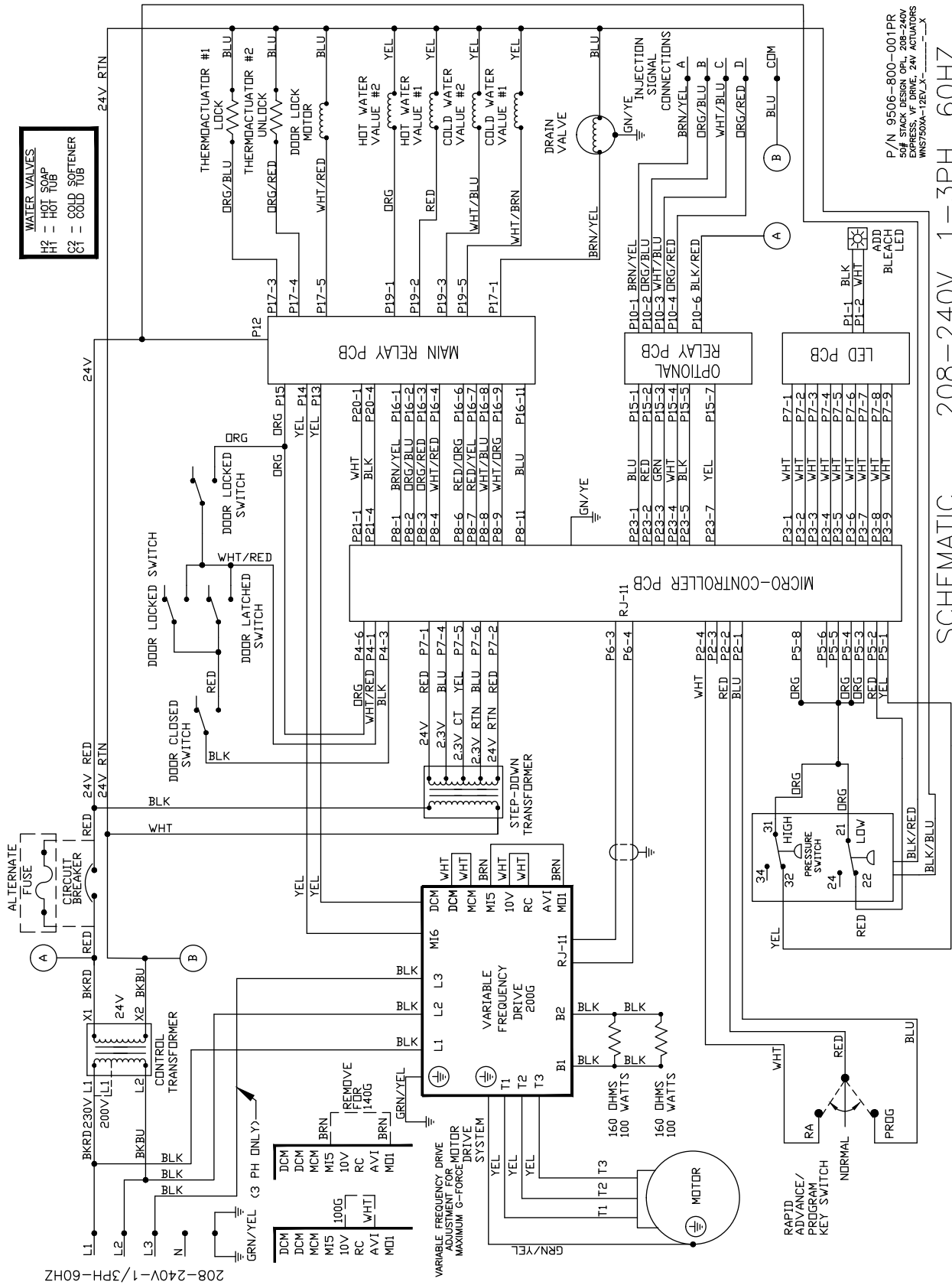

P/N 9506-800-001PR  
 50# STACK DESIGN OPL 208-240V  
 EXPRESS, VF DRIVE, 24V ACTUATORS  
 WNS7500A-12EV\_X







# Section: 10

## Washer Parts

---

## Kits, Assemblies, & Common Parts

Description	Part Number
Kit - Door Lock Assy. & Cam, replaces 9885-024-001	9732-347-001
Kit - Door cam replacement	9732-346-002
Kit - Locking Pawl replacement	9732-346-001
Kit - 8650-012-003 Lock with spacer	9732-344-001
Kit - 3" Drain valve seal replacement	9732-327-001
Drain Valve 3"	9379-202-001
Water Valve	9379-183-013
Diaphragm	9118-049-003
Electronic Pressure Switch	9732-315-001
Braking Resistors	9483-004-003
Transformer	8711-004-004
Control Board	9473-010-001
Data Cable	9806-015-002
Door Lock Gear Motor Assembly	9892-017-002
Door Lock Latching Assembly	9885-024-001
Door Handle	9244-091-001
Door Switch	9539-492-001
5/16 Hex Screw	9545-008-026
Belt	9040-076-008
Door Glass Gasket	9206-431-001

## SWD Accessories T-750

Key	Description	Part Number	Qty
*	Hose, Water Supply 5/8" I.D. x 48"	9990-027-013	2
*	Washer, Inlet Hose (furnished)	8641-242-000	2
*	Strainer, Inlet Hose (furnished)	9565-003-001	1
*	Sealing compound	8538-151-002	1
*	TORX#20	8545-051-002	1
*	Flow Restrictors (in dispenser )	9475-002-003	3
*	Battery 3V Lithium (used on Control PCB)	8612-001-001	1
*	OPL Bearing & Seal Kit	9732-219-007	1
*	Mode Light Support	9635-022-001	1

## Wiring Harnesses Parts

Key	Description	Part Number	Qty
1	Add Bleach Light, (Wiring Harness included)	9794-001-001	1
2	Wiring Harness, Door Lock P15/P4	9627-816-003	1
3	Wiring Harness, Optional Relay Board (Soap Injection)	9627-835-001	1
*	Wiring Harness, Optional Relay Board to Soap Injection terminal block	9627-799-001	1
4	Wiring Harness, Drain,Thermo,Door Gear Motor P17	9627-820-002	1
5	Data Cable	9806-015-002	1
6	Wiring Harness P20/P21	9627-818-002	1
7	Wiring Harness P8/P16	9627-819-001	1
8	Wiring Harness Water Valve/P19	9627-795-004	1
9	Wiring Harness LED PCB	9627-821-001	1
*	Wire Yellow Jumper (water valve)	8220-123-001	1
*	Harness Power Terminal Block	9627-747-003	1
10	Harness-Extention, Transformer	9627-826-001	1
12	Harness-P5/Pressure Switch	9627-807-002	1
*	Circuit Breaker 7 AMP	5198-211-002	1
*	Wiring label-schematic	9506-800-001	1

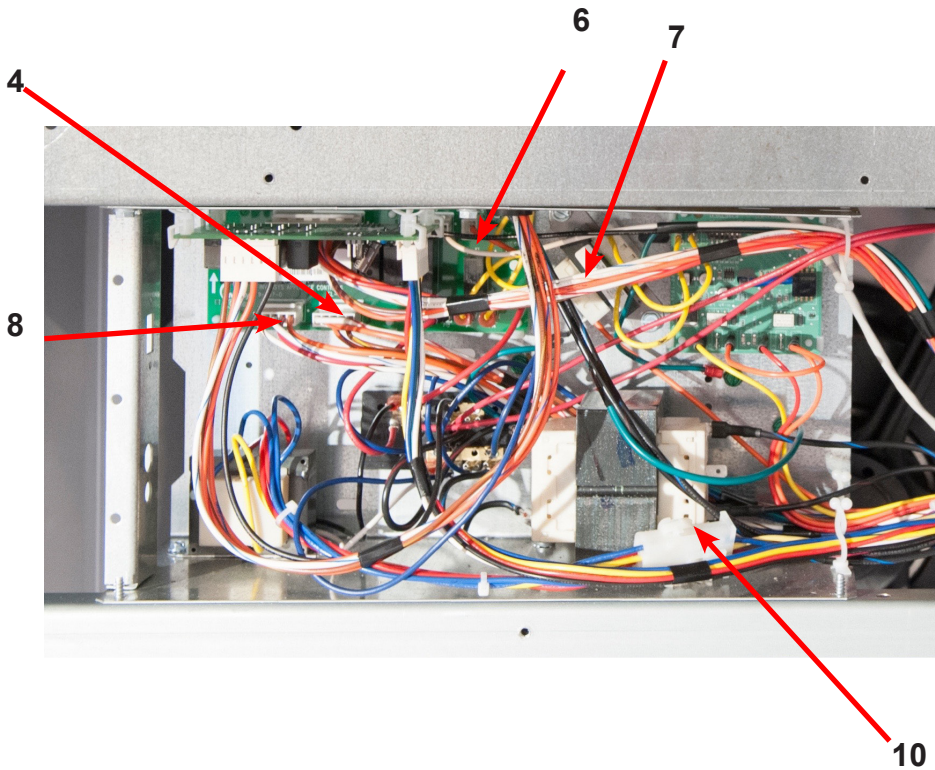
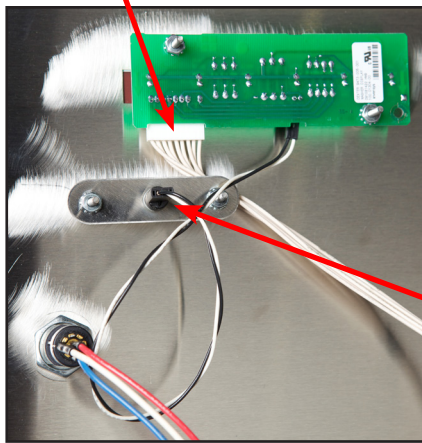
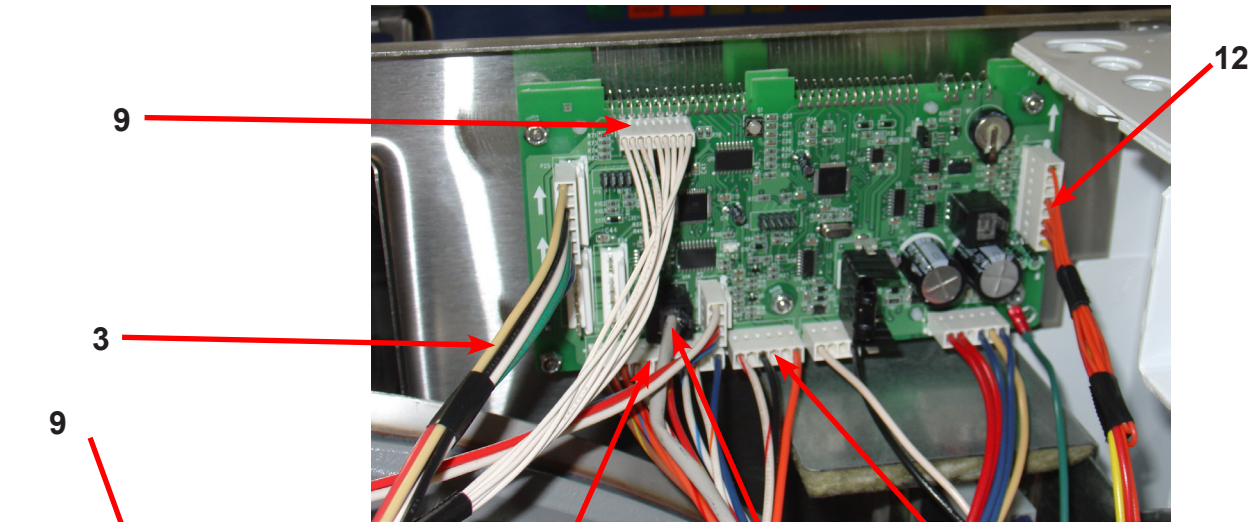

# WNS 750 Rear View Access Parts Group Part #

Key	Description	Part Number	Qty
1	Drive Motor, 3 Phase (Inverter duty)	9376-329-001	1
2	Rod, Motor Mtg	9497-222-004	1
3	Motor Bushing (Rubber)	9053-082-001	2
*	Clamp-Worm, 316SS, 1.5"	8654-117-019	2
4	Spring, Belt Tension	9534-151-000	1
*	Chain, Belt Tension	9099-012-003	1
*	Bolt, Eye (1/4"-20x21/2")	9545-055-001	1
*	Nut, 1/4 Elastic Stop	8640-414-003	1
*	Pulley, Motor	9453-179-001	1
*	Bushing-split taper	9053-077-001	2
*	Screw-Motor pulley 1/4 20x1	9545-018-024	1
5	Pulley, Driven	9453-173-002	1
*	Screw 5/8-11x2"	9545-060-004	1
*	Lockwasher 5/8"	8641-582-018	1
*	Washer, Flat 5/8x2 1/4"	8641-581-032	2
6	Drive Belt	9040-076-008	2
7	Channel, Rear	9081-180-001	1
*	Screw	9545-008-026	4
*	Nut, Spring	8640-399-007	4
*	Hose, Overflow to drain	9242-449-003	1
*	Clamp, Hose overflow to drain	8654-117-018	2
8	Hose, Overflow Vent Top	9242-463-005	1
*	Clamp, Hose Vent	8654-117-008	1
9	Vacuum Breaker ALL	9610-001-001	1
10	Bracket, Vacuum Breaker	9029-275-001	1
*	Vacuum Breaker Cap (Red)	0935-135-002	*
11	Screw, 12B x 1/2	9545-008-026	2
12	Screw, 10ABX x 1/2	9545-048-001	2
*	Plastic Plug 7/8" Electrical Connection	9456-041-006	1
13	Panel Assy., Back	9454-928-001	1
*	Screw Panel Mtg.#10Bx1/2"	9545-008-026	11
*	Screw Panel Mtg.#1/4Bx3/4"	9545-030-002	3
*	Nut, Spring	8640-399-004	8
14	Hose, Pressure Switch	9242-175-008	1
*	Clamp, Pressure Switch Hose	8654-117-015	1
*	Anchor-wire tie	9004-007-001	1
*	Strap-tie adjustable	9544-040-001	1
15	VFD Delta "E" drive 208-240 volt	9375-028-025	1
*	VFD Cooling Fan	9189-013-001	1
16	Braking resistors (160 ohm)	9483-004-003	2
17	Bracket assembly (drive mounting)	9985-119-002	1
*	VFD, MS300, V4	9375-036-019	1
*	VFD Cooling Fan	9189-016-001	1
*	Data Cable, MS300, V4	9806-026-003	1

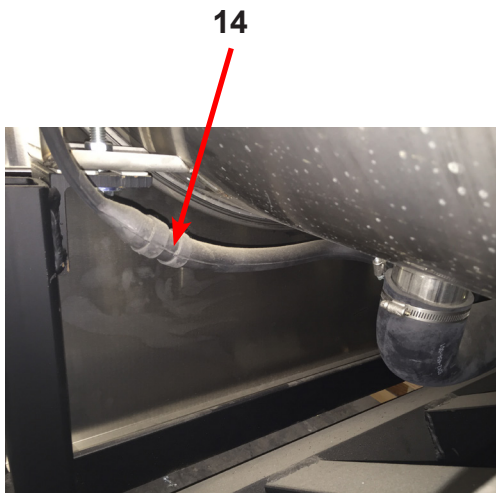
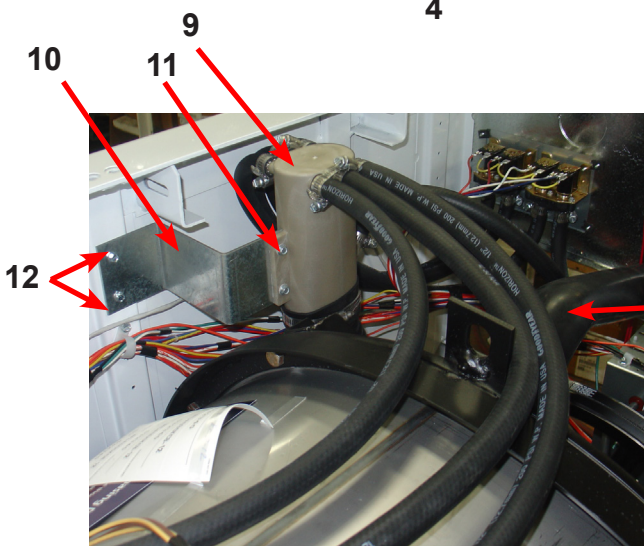
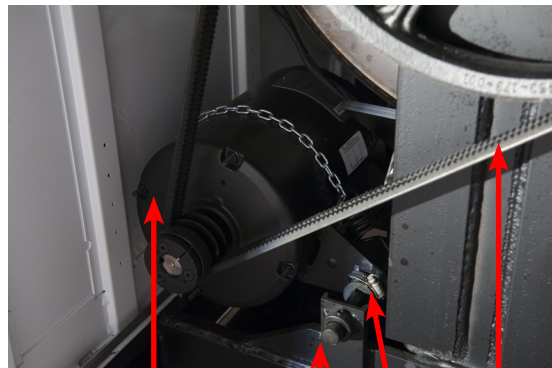
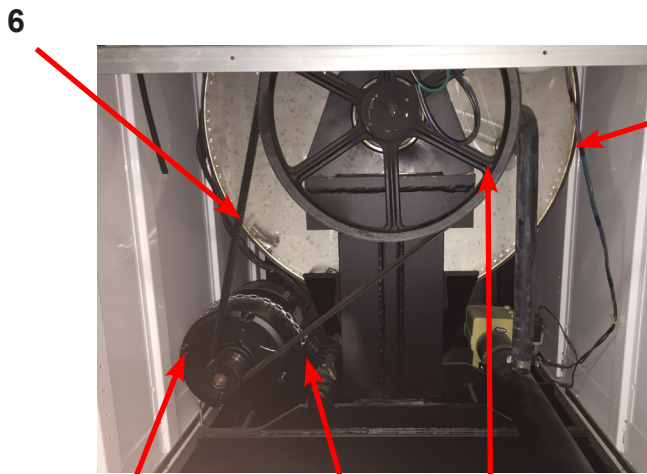

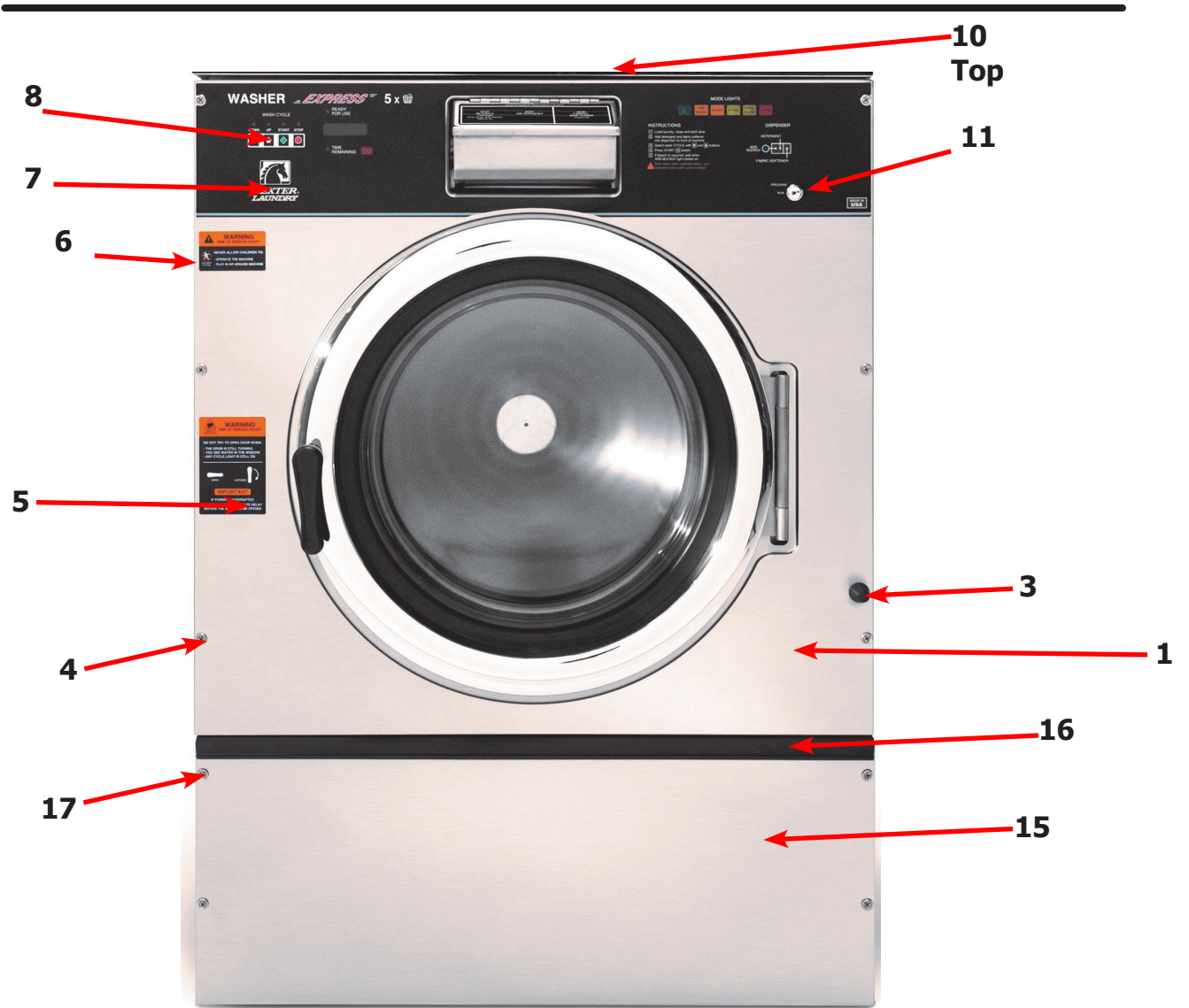

## Cabinet and Front Panel Group

	Description	Part Number	Qty
*	Panel, Right Side-Painted	9989-574-002	1
*	Panel, Left Side - Painted	9989-575-002	1
*	Strap assy-studs	9966-017-001	2
*	Strap assy-studs	9966-019-001	2
*	Shim-Side Panels	9552-046-001	2
*	Nut-hex 1/4-20unc,2b	8640-414-006	10
1	Panel Assy, Front	9989-579-001	1
*	Trim Edge Protector	9578-092-005	1
3	Bumper Loading Door	9051-055-001	1
4	Screw, 10bx1 3/4	9545-008-014	6
*	Washer Finish	8641-585-001	6
*	Nut, Spring-To Front Panel	8640-442-001	10
5	Label, Door Opening, Black	8502-757-001	1
6	Label, Risk of Injury, Black	8502-759-001	1
7	Nameplate Decal, Control Panel, Black	9412-234-001	1
8	Button, Push Control, Black	9035-062-003	1
10	Panel Top, Front, Painted	9989-576-002	1
*	Screw, Hex, #10B x 1/2	9545-008-026	12
*	Cover Top Rear	9074-367-001	1
*	Screw, Hex, #10B x 1/2	9545-008-026	4
11	Lock-Run/program w/harness	8650-027-001	
12	Soap Dispenser Assembly, Complete (Does not include lid)	9807-087-001	1
*	Soap Box mounting Gasket	9206-425-001	1
13	Lid Assembly soap box	9987-104-001	1
*	Lid screws #10-32x1/2 SS	9545-012-017	2
*	Nut Hex Elasticstop #10-32 SS	8640-413-006	6
*	Bracket Soap box mounting	9029-122-002	1
*	Softener siphon tube (plastic)	9574-252-002	1
*	Flow restrictors	9475-002-003	3
14	Label, Dispenser Instructions, Black	8502-756-001	1
15	Door, Lower Service	9108-137-001	1
16	Handle, Lower Service Door	9244-086-003	1
17	Screw, 10bx 1 3/4	9545-008-014	4
*	Washer Finish	8641-585-001	6

## Cylinder, Seals & Bearings Part # by Model

Key	Description	T-750	QTY
1	Bearings and Seal Kit	9732-219-007	1
*	Housing, Bearing- Assembly (items #2-#6)	9803-187-001	1
2	Housing, Bearing	9241-181-004	1
3	Bearing, (Small)	9036-159-006	1
4	Bearing, Front (Large)	9036-159-005	1
5	Spacer, Bearing	9538-170-001	1
6	Ring, Bearing Retainer	9487-238-004	1
8	Seal, Small V85A	9532-140-007	1
9	Seal, Large V140A	9532-140-008	1
10	Ring, Seal Mounting	9950-052-001	1
11	Tub Back Mating Ring	9487-261-004	1
11G	Mating Ring Guard Shield	9487-266-001	1
12	Bolt, Tub End of Bearing Housing (7/16-14x1), Bolt from inside Tub	9545-059-004	6
13	Washer, Flat	8641-581-034	6
14	Screw-Hex Cap, 3/4"-10 x 3" (Bearing Housing to Frame)	9545-057-002	6
15	Washers Spherical 3/4 (Male half) (Bearing Housing to Frame)	8641-588-001	6
16	Washers Spherical 3/4 (Female half) (Bearing Housing to Frame)	8641-588-002	6
17	Nut 3/4"-10 (Bearing Housing to Frame)	8640-418-003	6
18	Pulley, Driven	9453-173-002	1
*	Tolerance Ring	9487-234-004	1
*	Screw, 5/8"-11 x 2"	9545-060-004	1
19	Washer-Flat .675x2-1/2x1/4	8641-581-032	1
20	Lockwasher-Exttooth, 5/8	8641-582-018	1
21	Bolt, 5/8-11x1 1/2	9545-060-004	1
22	Tub & Cylinder Assy	9869-036-001	1
23	Cylinder Assy	9848-136-002	1
*	Tub Front	9974-011-002	1
*	Gasket, Tub Front	9206-421-002	1
*	Ring Assy, Tub Mtg-Front Clamp	9950-055-001	1
*	Bolt, Top Front Ring 3/8"-16 x 3"	9545-029-009	1
*	Nut 3/8"-16	8640-415-001	1

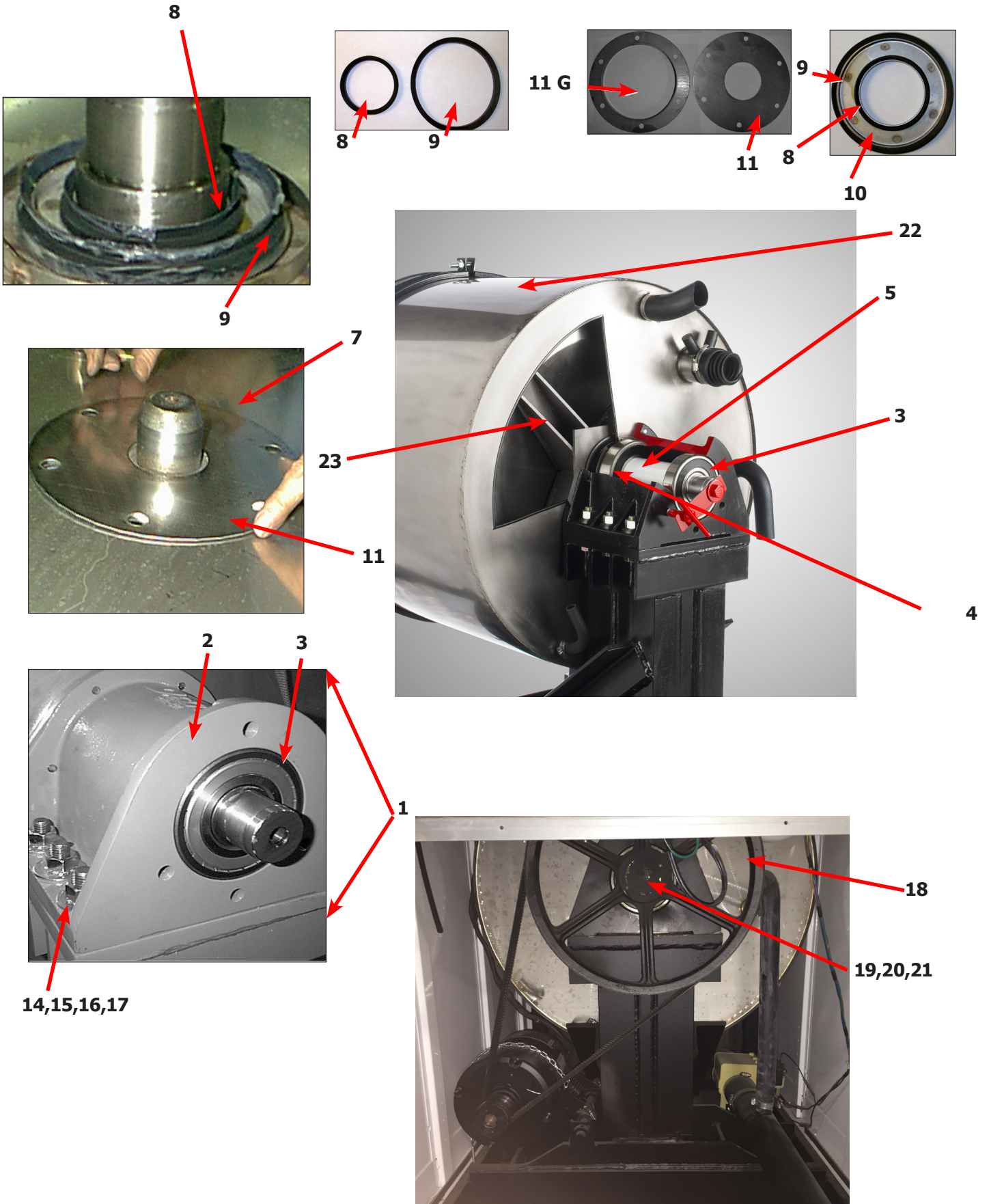

## Door Lock Assembly (continued)

Key	Description	Part Number	Qty
33	Lock Assy, Complete (#1-22)(includes #1 thru #22)	9885-031-001	1
1	Plate Assy, Door Lock	9982-346-001	1
2	Washer, Flat	8641-581-030	1
3	Actuator, Latching Switch	9008-005-001	1
4	Pawl, Locking	9732-346-002	1
5	Washer, Spring	8641-569-003	1
6	Ring, Retaining	9487-200-004	1
7	Bracket Switch	9029-163-001	1
8	Nut, Hex 10-32 UNF	8640-413-002	2
9	Spring, Actuating	9534-364-002	1
10	Screw, Hx. 10-32 x 1"	9545-012-020	1
11	Nut, Elastic Stop 10-32	8640-413-004	2
12	Spring, Return	9534-364-001	2
13	Pin, Guide	9451-193-001	1
14	Ring, Retaining	9487-200-005	1
15	Washer	8641-581-031	1
16	Switch, Latching Sensing	9539-461-008	1
17	Shield, Switch	9550-169-003	3
18	Screw 4-40 x 5/8"	9545-020-001	2
18	Nut, Twin 4-40	8640-401-001	1
19	Switch, Locking Sensing	9539-461-007	2
20	Actuator, Switch Locking	9008-006-003	1
21	Screw 4-40 x 1 1/8"	9545-020-003	2
21	Nut, Twin 4-40	8640-401-001	1
*	Spacer Sensor	9538-182-001	*
*	Shim, Door Lock, Thin	9552-037-001	AR
*	Screw, Lock mtg 1/4"-20 x 3/4"	9545-018-014	3
*	Lockwasher 1/4" Ext tooth	8641-582-007	3

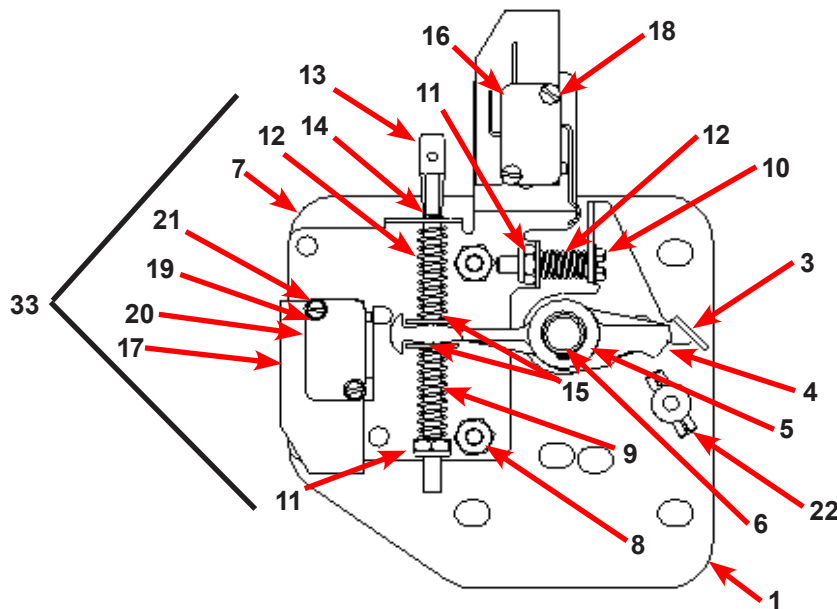

# Gear Motor Door Lock Assembly

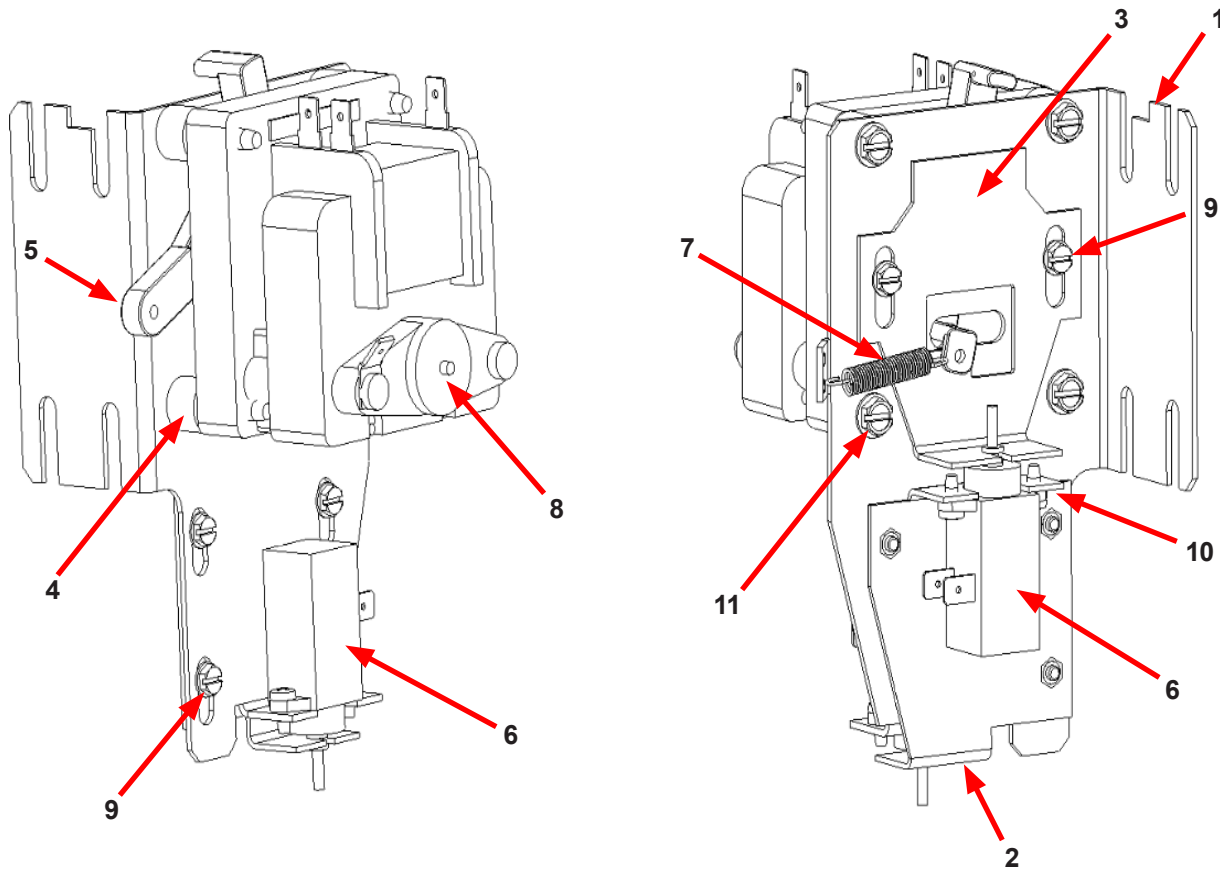

Key	Description	T-750	QTY
*	Actuator Assembly (Includes 1-10, Rod NOT included)	9892-017-002	1
1	Bracket Assy, Slide Lock Actuator	9985-199-001	1
2	Bracket Assy, Slide - Unlock	9985-196-001	1
3	Bracket Slide Lock	9029-278-001	1
4	Spacer, Plastic	9538-157-021	4
5	Arm - Door Lock	9001-063-001	1
6	Thermoactuator - Door Lock Relay 24v	9586-001-003	2
7	Spring - Extension	9534-350-001	1
8	Motor & Gear Assembly 24v	9914-137-014	1
9	Screw -Hxwshrdslsems, 6-32 x 3/16	9545-044-003	6
10	Cross Recessed PAn Hd Tapping screw	9545-031-011	4
11	Screw hxwshdsl, 10-24 - 1.25f, ctd	9545-046-007	4
*	Rod, Door Lock	9497-231-001	1
*	Harness, Door Lock/Drain, P17	9627-816-003	1

# Large Door & Hinge Group

Key	Description	T-750	QTY
1	Door Hinge Assembly (mounts to tub front)	9955-031-001	1
*	Door Assembly Complete	9960-310-001	1
2	Door Ring 180 degree large hinge	9487-275-001	1
3	Door Gasket	9206-431-001	1
4	Door Glass Window	9635-020-001	1
*	Red Wire (Door Close Switch)	8220-063-028	1
*	Black Wire (Door Close Switch)	8220-063-029	1
5	Switch, Door Hinge Close (Plunger)	9539-492-001	1
6	Top Door Hinge Leaf	9845-006-001	1
7	Bottom Door Hinge Leaf	9845-007-001	1
8	Thrd Form Screw, Door Mtg 5/16" x 5/8"	9545-056-002	4
9	Screw, Loading Door Hinge Mtg (5/16" x3/4" ss)	9545-014-009	3
9	Lock Washer, exttooth 5/16	8641-582-009	3
*	Shim Large door	9552-043-001	1
*	Gusset side panel RH	9210-128-003	1
*	Gusset side panel LH	9210-128-002	1

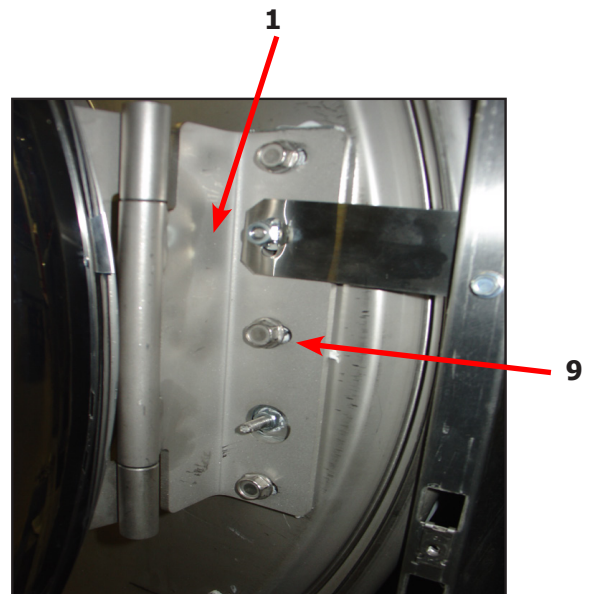

Key	Description	T-750	QTY
*	Shaft Assembly-Loading Door (11-14)	9913-136-001	1
11	Shaft, Door Locking	9537-195-002	1
12	Cam, Locking	9095-051-001	1
13	Pin, Groove (1 1/4)	9451-181-005	1
14	Pin, Groove (3/4)	9451-181-004	1
15	Spring, Lock Cam	9534-360-002	1
16	Handle, Door	9244-091-001	1
17	Pin, Door Handle (groove)	9451-181-005	1

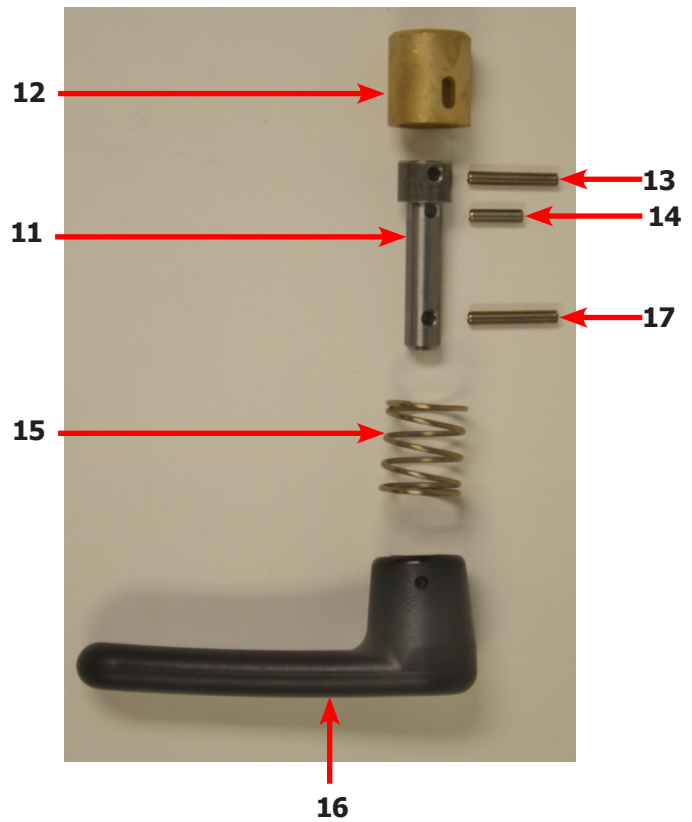
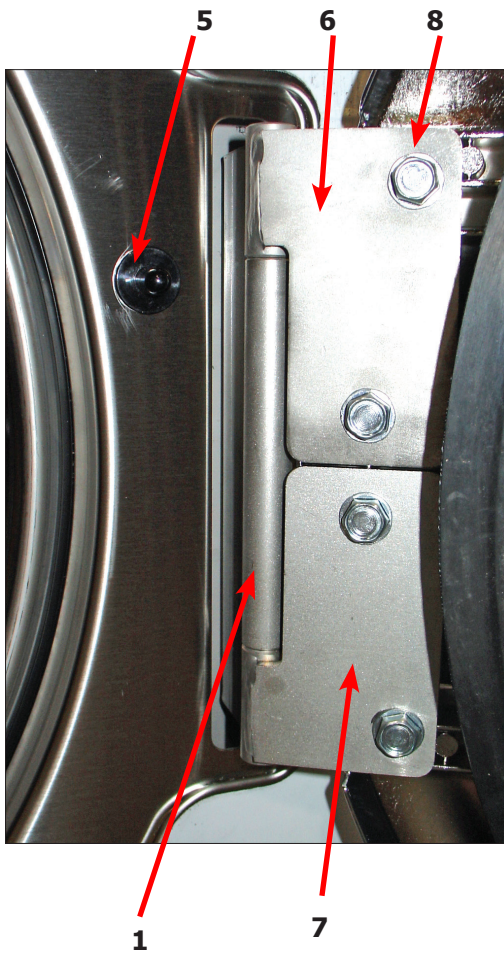

# Drain Valve Group Part # by Model

Key	Description	Part Number	Qty
1	Valve, Drain (includes #2 thru #11)	9379-202-002	1
2	Body, Valve (w/ball)	9064-072-001	1
3	Motor & Gear Train (complete)	9914-137-022	1
4	Plate, Motor Mtg	9452-538-001	1
5	Screw	8639-994-001	1
6	Spring, Drive	9534-339-001	1
7	Screw	9545-054-001	1
8	Screw	9545-054-002	1
9	Seal, V Packer	9532-134-001	1
10	Washer	8641-584-001	1
11	Pin, Main Drive	9451-196-001	1
12	Kit - Seal Replacement	9732-327-001	1

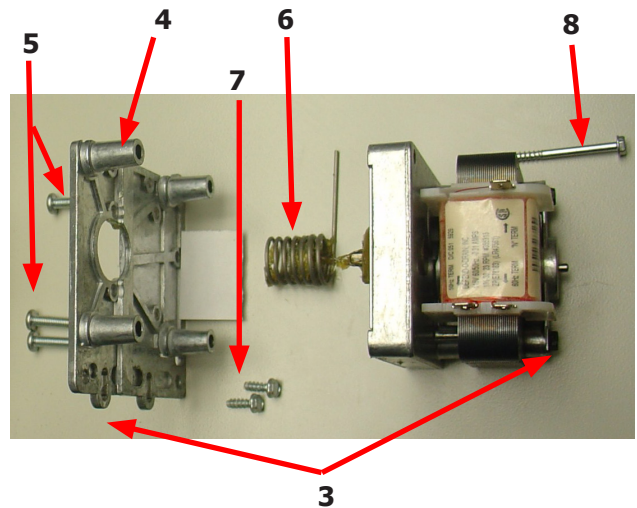
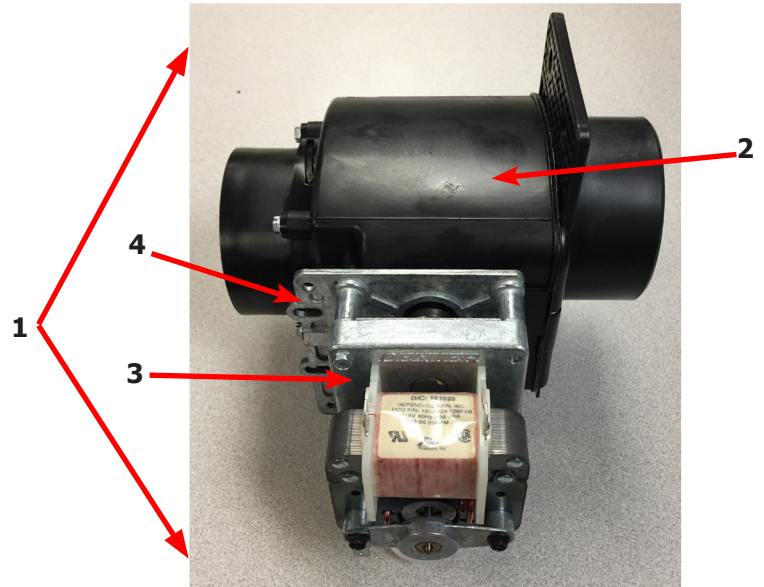
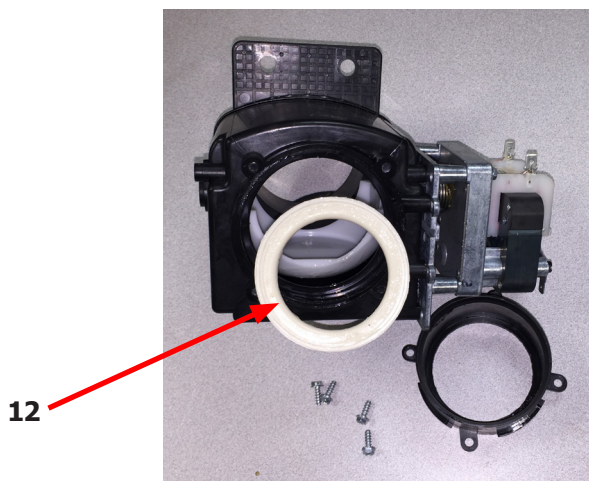

# Water Inlet Valve Breakdown

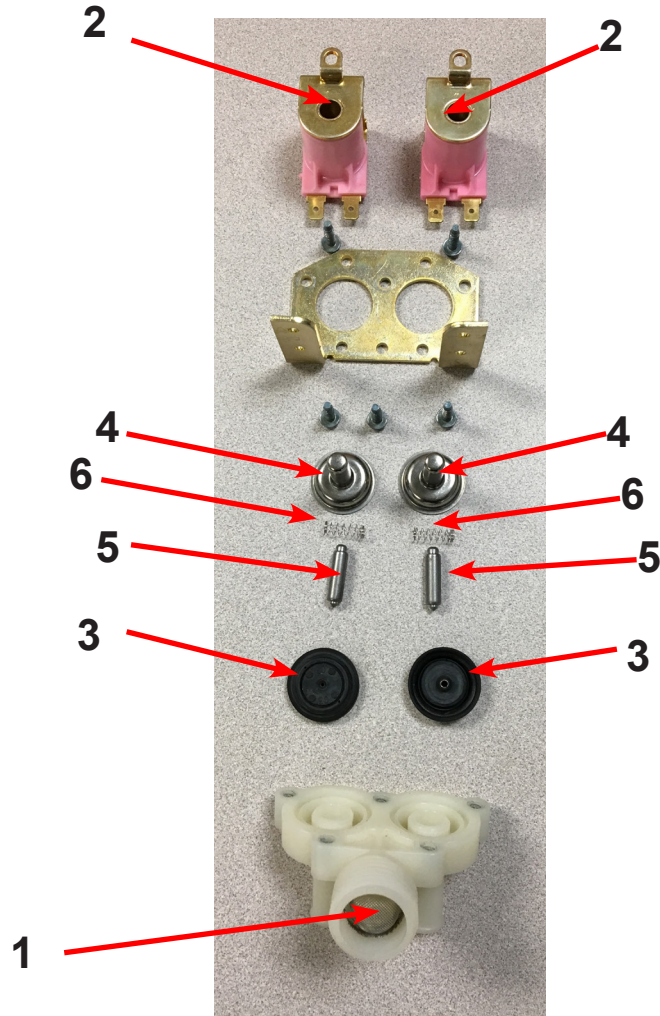

Key	Description	Part Number	QTY
*	Valve, Water Inlet (includes 1 thru 6) - <b>Invensys</b>	9379-183-013	2
1	Screen, Inlet end of valve	9555-056-001	2
2	Coil Assy., 24 V Invensys	9089-017-004	2
3	Diaphragm Invensys (EPDM)	9118-049-003	2
4	Guide, Solenoid Invensys	9211-021-002	2
5	Armature Invensys	9015-008-001	2
6	Spring, Armature Invensys	9534-298-001	2

## Chassis and Drain Part # by Model

Key	Description	T-750	QTY
1	Base Assy,Frame	9945-144-002	1
2	Outer Tub Assy	9930-171-001	1
*	Tub & Cylinder Assy	9869-036-001	1
3	Tub Front	9974-011-002	1
*	Gasket, Tub Front	9206-421-002	1
4	Ring Assy, Tub Mtg-Front Clamp	9950-055-001	1
5	Bolt, Top Front Ring 3/8"-16 x 3"	9545-029-009	1
6	Nut 3/8"-16	8640-415-001	1
7	Bolt, 1/2" -13 x 2" (Tub Mounting to Frame)	9545-017-013	2
8	Nut, Wizloc 1/2" x 13	8640-417-005	2
9	Washer, Flat 1/2"	8641-581-026	2
10	Hose, Tub to Drain Valve	9242-456-001	1
11	Clamp, Hose (Tub to Drain Valve)	8654-117-014	2
12	Valve, Drain	9379-202-002	1
*	Screw, Valve to Base 1/4Bx3/4	9545-030-002	2
*	Washer, Flat 1/4	8641-581-018	4
13	Hose, Drain Valve to Tube	9242-457-001	1
*	Clamp, Hose (Drain Valve to Tube)	8654-117-014	1
14	Tube Assy, Drain	9915-131-002	1
15	Clamp, Hose (Tube to Frame Bracket)	8654-117-014	1
*	Screw Tube (Bracket to Base 1/4Bx3/4)	9545-030-002	4
16	Hose, Overflow Tub To Drain Tube	9242-449-003	1
*	Clamp, Hose	8654-117-018	1
*	Tube, Suds overflow	9242-463-005	1
*	Clamp, Hose	8654-117-008	2
17	Hose, Pressure switch	9242-175-008	1
	Clamp, Hose	8654-117-015	1
18	Injection Assy-Soap	9883-013-001	1
*	Cap- Injector assembly	0935-127-001	

**18**

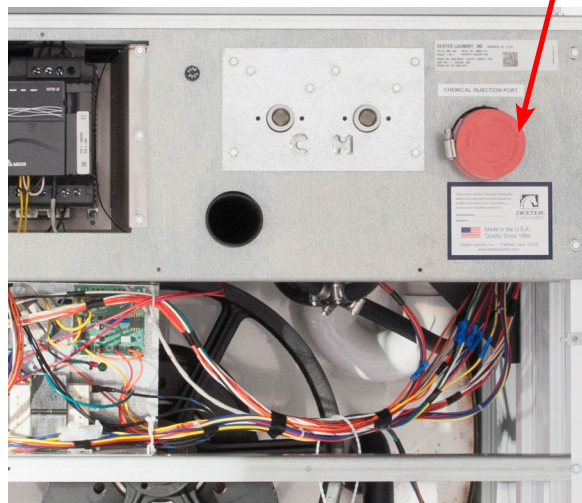

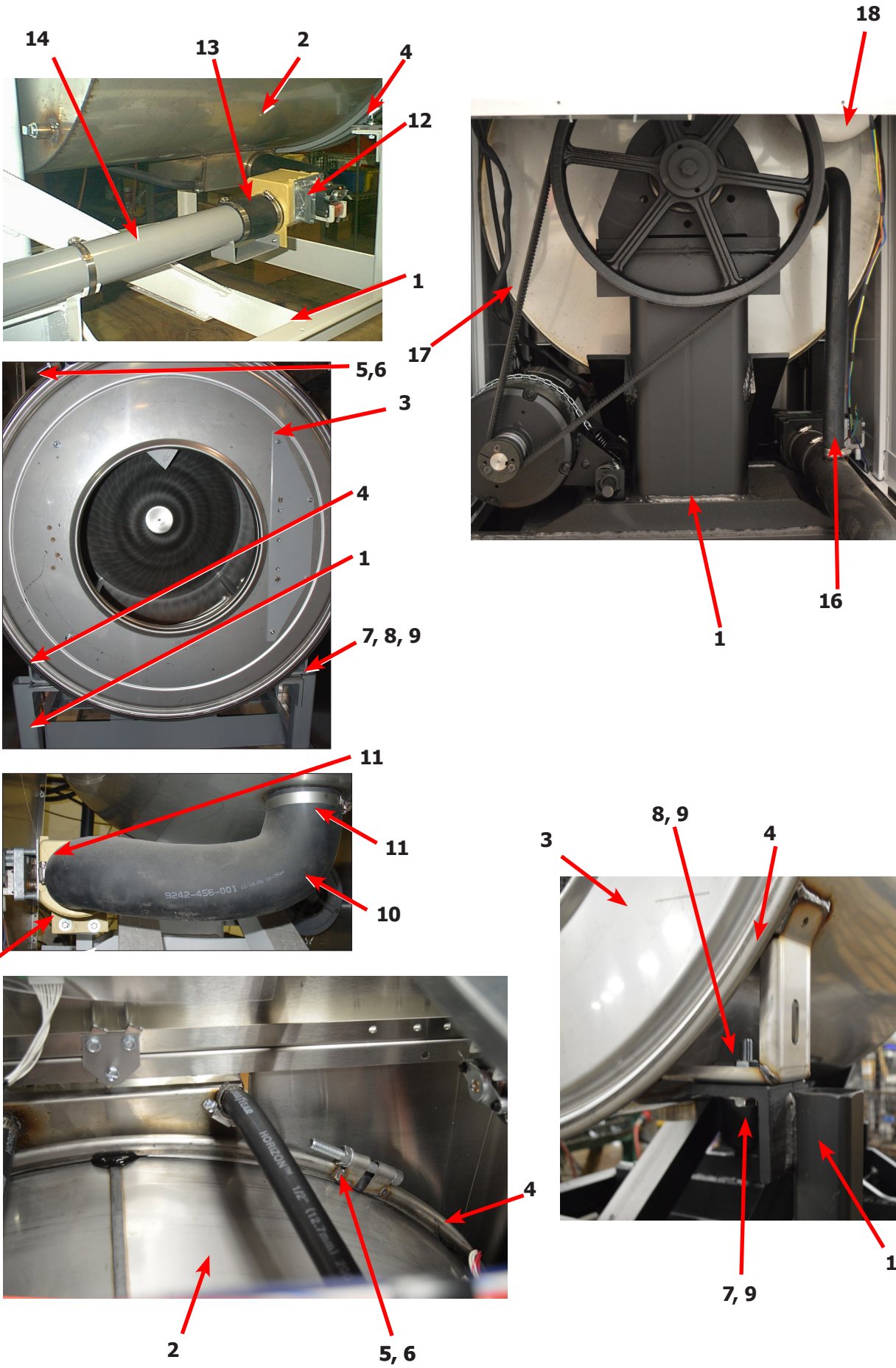

# Electrical Components, Control Trough

Key	Description	Part Number	Qty
1	Trough Assy,Controls 208-240 volt	9857-226-001	1
	Trough only	9839-018-001	1
2	Transformer, Control (208/230/60 Hz In 24 VAC Out Volts)	8711-004-004	1
*	Wire Assembly, Red 28"	8220-062-025	2
*	Screw, #10B x 1/2	9545-008-026	4
*	Lockwasher #10	8641-582-006	4
*	Wire Assembly, BLK/BLU	8220-001-231	1
*	Wire Assembly, BLK/RED	8220-001-230	1
3	Terminal Block Assy, POWER	9897-026-004	1
*	Screw, Mtg 8ABx1/2"	9545-045-012	2
*	Harness-extention, Transformer	9627-826-001	1
*	Screw, 8B x 1/4"	9545-045-001	2
*	Lockwasher-External Tooth, #6	8641-582-005	2
*	Wire Assembly, P12, Red 7"	9631-381-018	1
4	PCB assembly Relay Main	9473-006-001	1
*	PCB support 3/8 edge Holding	9548-285-001	10
*	Wiring Harness, Door Lock P15/P4	9627-816-003	1
*	Wiring Assembly Yel. 32" P14 & P13	8220-064-023	2
5	Wiring Harness, Drain,Thermo,Door Gear Motor P17	9627-820-002	1
6	Wiring Harness Water Valve/P19	9627-795-004	1
7	Wiring Harness P8/P16	9627-819-001	1
*	Wiring Harness P20/P21	9627-818-002	1
8	Sensor-Pressure Switch	9732-315-001	1
9	Harness Assembly, Pressure Switch	9627-807-002	1
10	Wiring Harness-Main	9627-914-002	1
11	Transformer	8711-010-003	1
12	Optional Relay board	9473-007-001	1

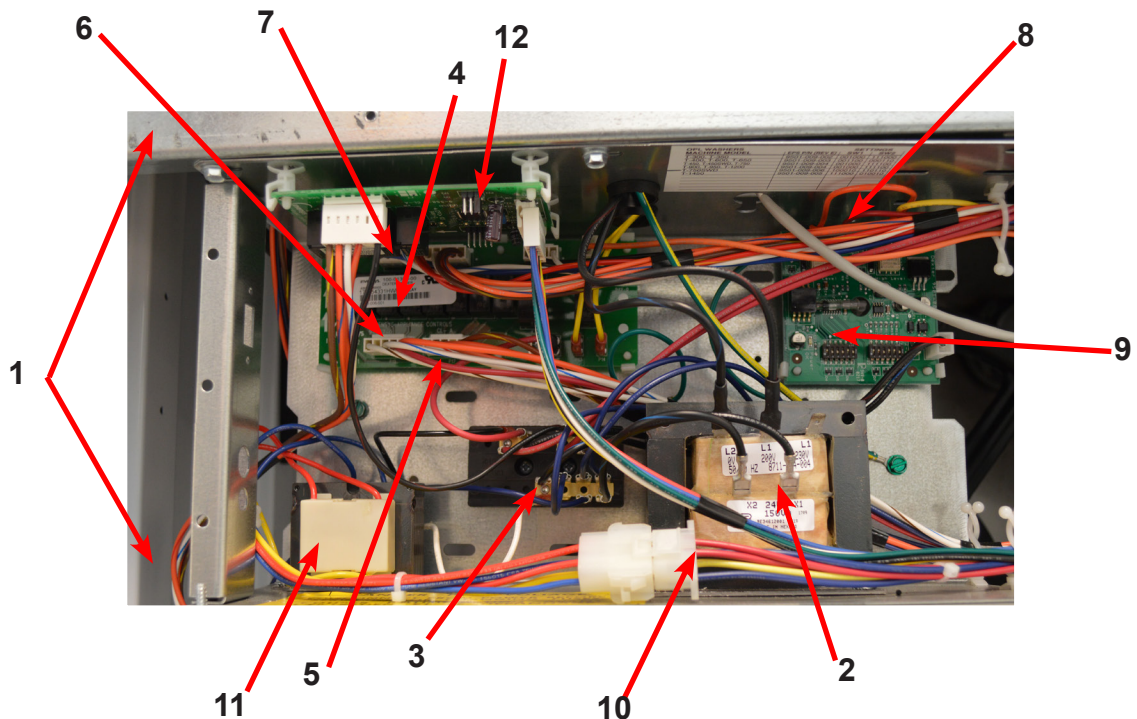

# Electrical Components, Upper Channel

Key	Description	Part Number	Qty
1	Terminal Block Assy, POWER	9897-033-002	1
*	Screw, Mtg 6ABx3/4"	9495-031-010	2
2	Strip, Terminal Marker	9558-025-001	1
3	Terminal, Lug-Solderless (Ground)	8652-134-001	1
*	Screw, 10-32TTx1/2 Green (Control Trough)	9545-008-027	
*	Wiring Harness Power Terminal To VFD & Control Transformer and ground wire	9627-747-003	1
4	VFD Delta drive 208-240 volt (Before Serial W1.20240.047)	9375-028-025	1
*	Cable, Data Communication	9806-015-002	1
*	VFD MS300, V4 (After Serial W1.20240.047)	9375-036-019	1
*	Cable, Data Communication, V4 MS300	9806-026-003	1
*	Wiring Assembly Yel. 32"	8220-064-023	2
5	Braking resistors (160 ohm)	9483-004-003	3
*	Wire Assembly-Jumper, BLK (Breaking Resistors)	8220-117-002	2
6	Circuit Breaker 1.5 AMP	5198-211-002	1
7	Terminal Block Assy, Injector	9897-032-002	1
8	Strip-termmarker	9558-028-002	
	Screw-pnhdtorx 4bx5/8 ss	9545-053-002	

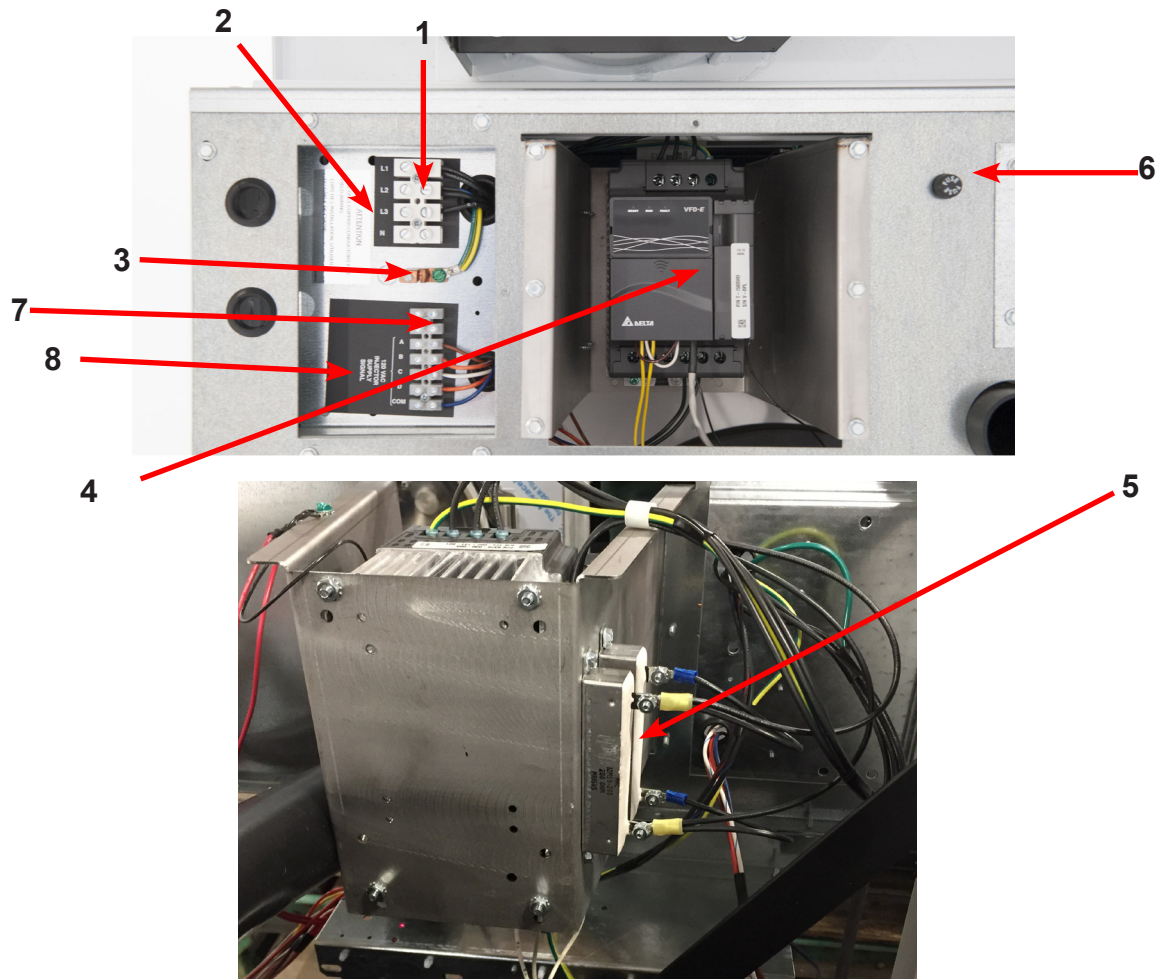

# Front Panel Control Group Part #

Key	Description	Part Number	Qty
*	Nameplate,Control Panel Black(one piece)	9412-234-001	1
1	PCB assembly Control /Display	9473-004-010	1
*	Spacer Push button (Micro)	9538-192-001	1
*	Retainer Push button (Micro)	9486-160-001	1
*	Nut Hexelasticstop #4-40	8640-424-002	2
*	Push button Control (coin)	9035-062-003	1
*	Spacer Plastic #6x9/16	9538-157-018	5
*	Nut Elasticstop #6-32	8640-411-002	4
*	Nut-Hexkeps, #6-32	8640-411-003	1
2	Harness LEDPCB	9627-821-001	1
3	Harness Doorlock, Switches	9627-816-003	1
4	PCB assembly Mode lights	9473-005-001	1
*	Spacer Plastic #6x9/16	9537-157-018	2
*	Nut Hexkeps #6-32	8640-411-003	2
6	Door Locking Actuator 24 volts	9892-017-002	1
*	Hex Nuts (mounting gear motor to control)	8640-412-005	4
7	Battery	8612-001-001	1
8	Add Bleach Light (Wiring Harness included)	9794-001-001	1
9	Lock Run/Program With Harness	8650-027-001	1

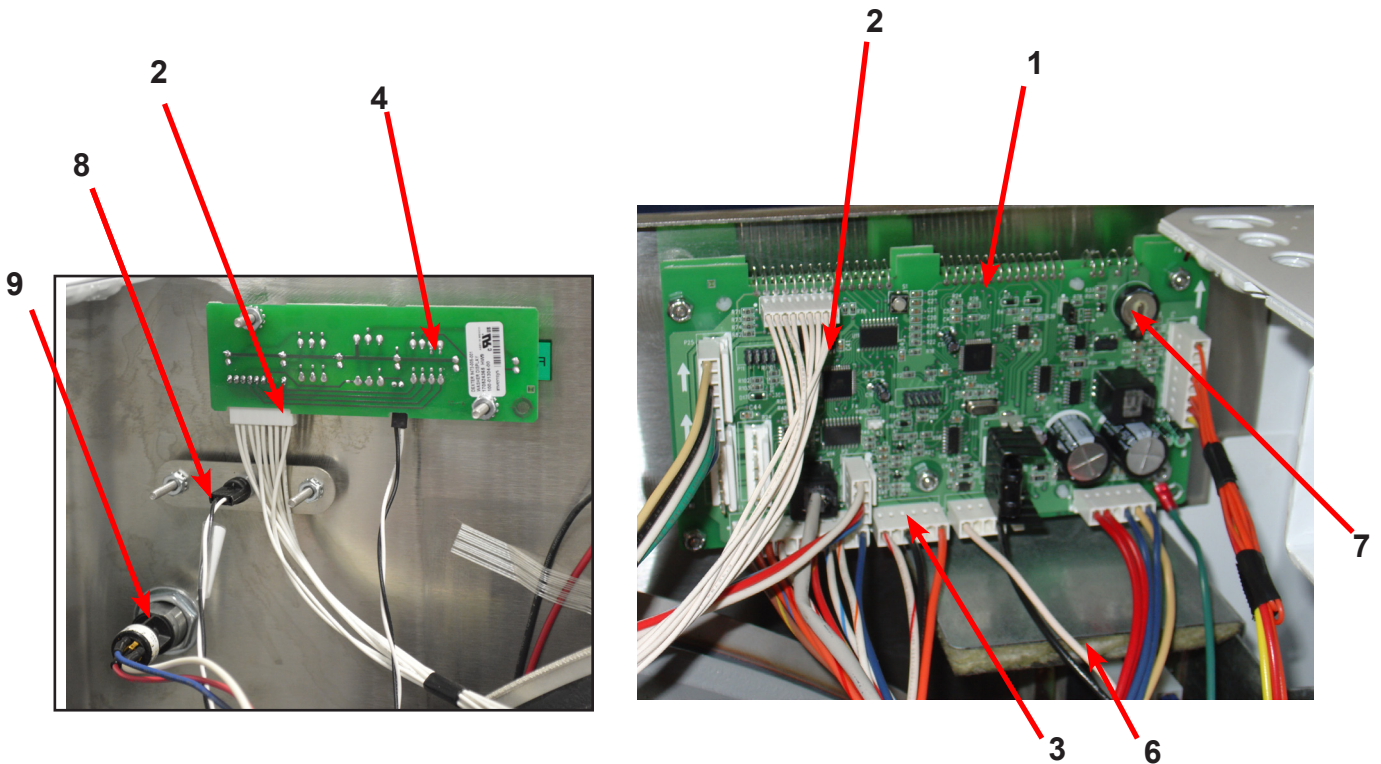

# Labels and Diagrams by Part #

Key	Description	Part Number	Qty
*	Wiring Diagram, OPL	9506-800-001	1
1	Label High Voltage Warning	8502-614-004	1
*	Cover controls	9074-267-001	1
2	Label Fusing & Installation	8502-619-004	1
3	Label Warning Risk of Injury Black	8502-759-001	1
4	Label Warning Door Opening Black	8502-757-001	1
*	Booklet Owners	8514-275-001	1
5	Label, Dispenser Instructions, Black	8502-745-001	1
6	Cover-Motor Control	9074-268-001	1







# SWD T-750-12 Diagram V4

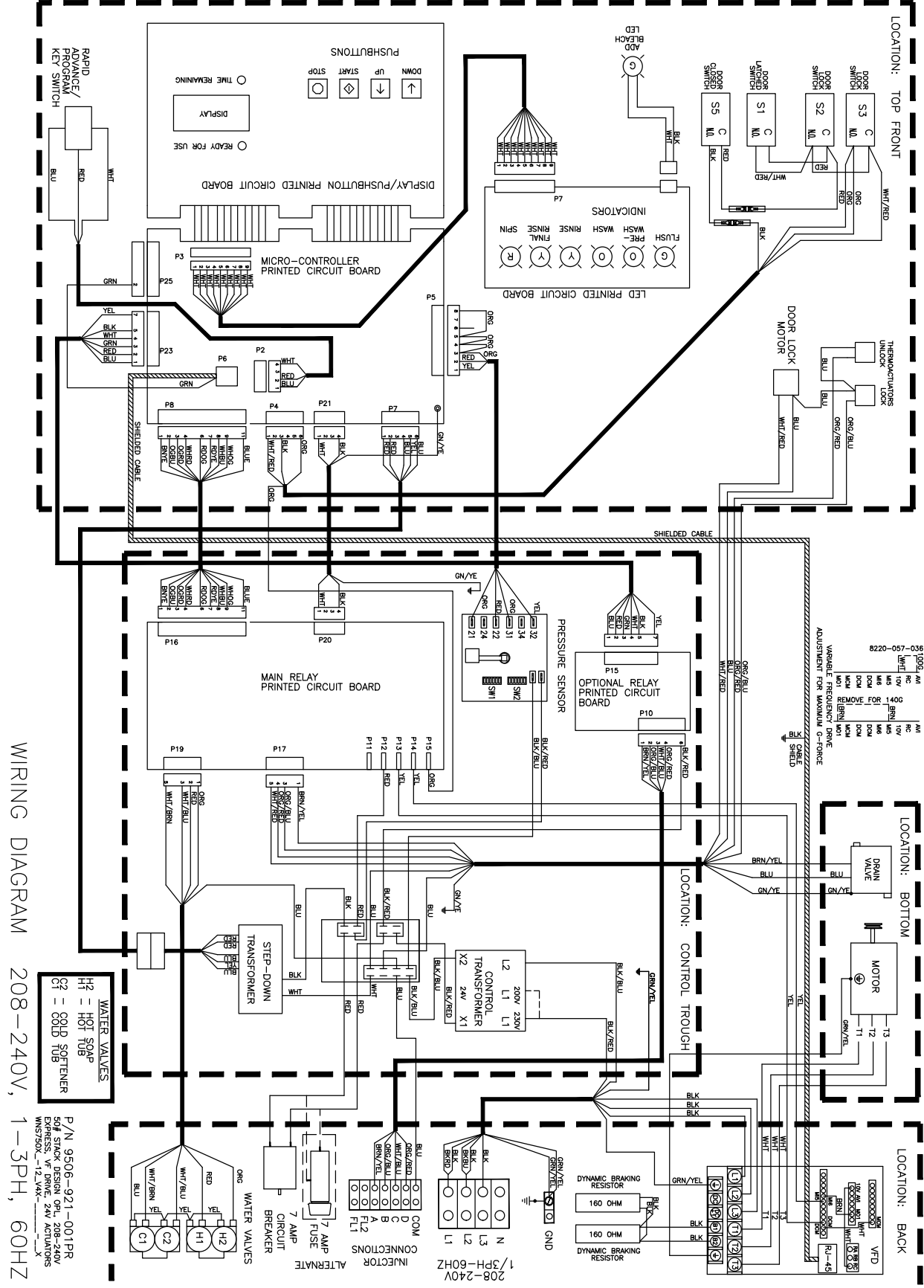

WIRING DIAGRAM

208-240V, 1-3PH, 60HZ

# SWD T-750-12 Schematic V4

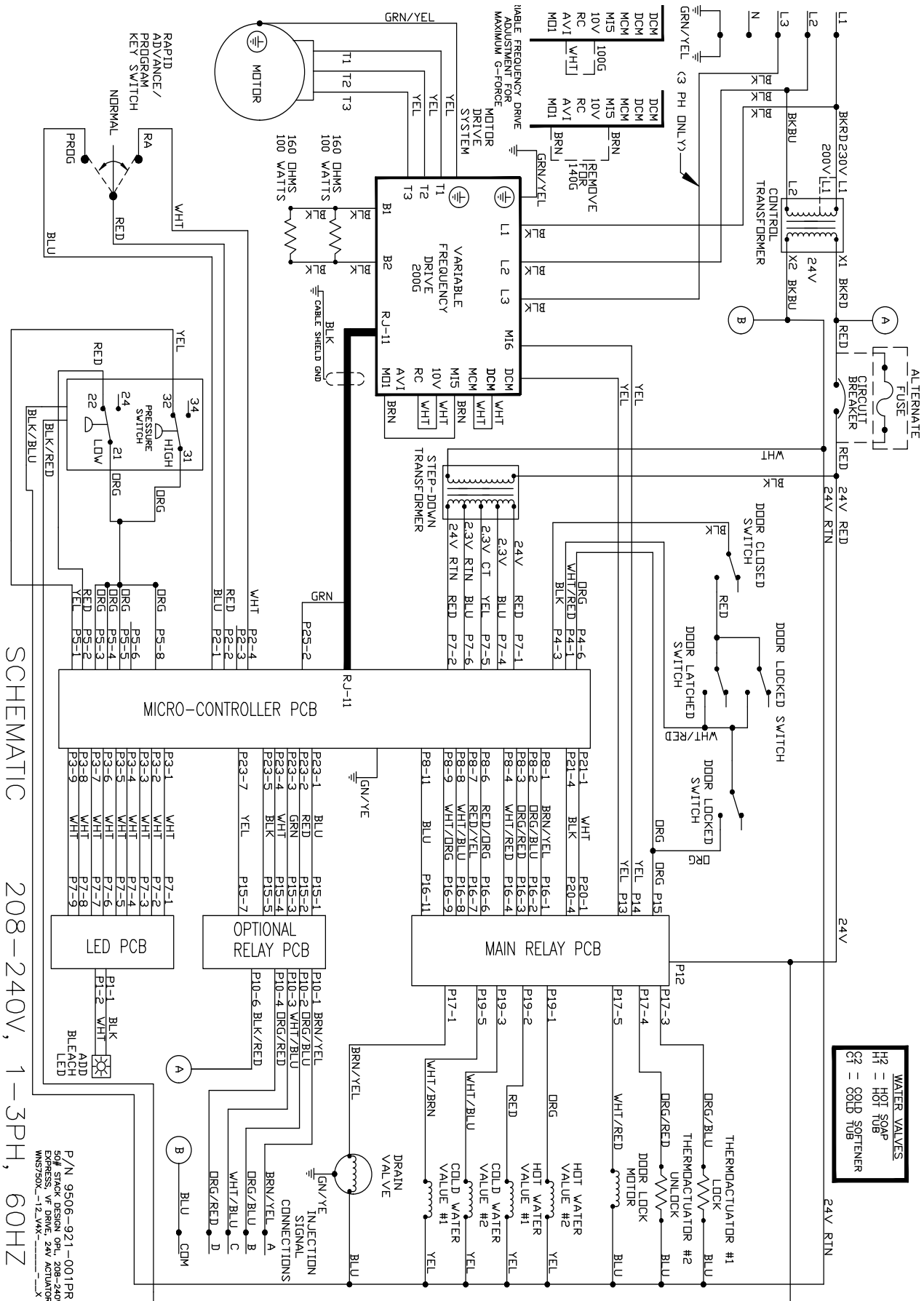

SCHEMATIC 208-240V, 1-3PH, 60HZ

P/N 9506-971-001PR  
50# STACK DESIGN OPT, 208-240V  
EXPRESS, VF DRIVE, 24V ACTUATOR  
WMS750X-12-VX-XXXXXX



---

# Section: 11

## 50 Hz Washer

### Models

Parts in this section used only in these models. All other parts are same as standard 60 Hz pages.

# Wiring Schematic for 50hz Washer -39

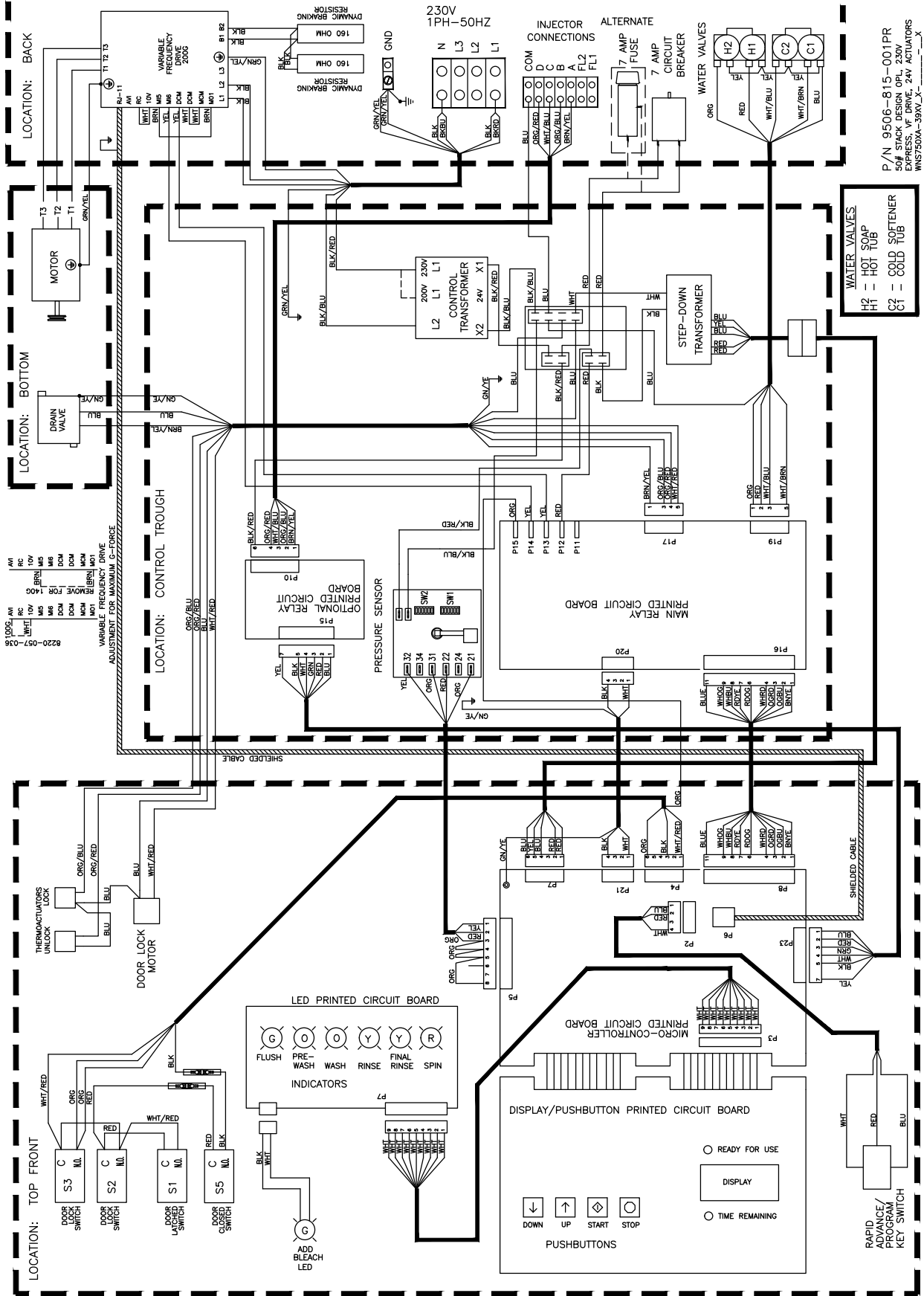

WIRING DIAGRAM 230V, 1PH, 50HZ

# Wiring Diagram for 50hz Washer -39

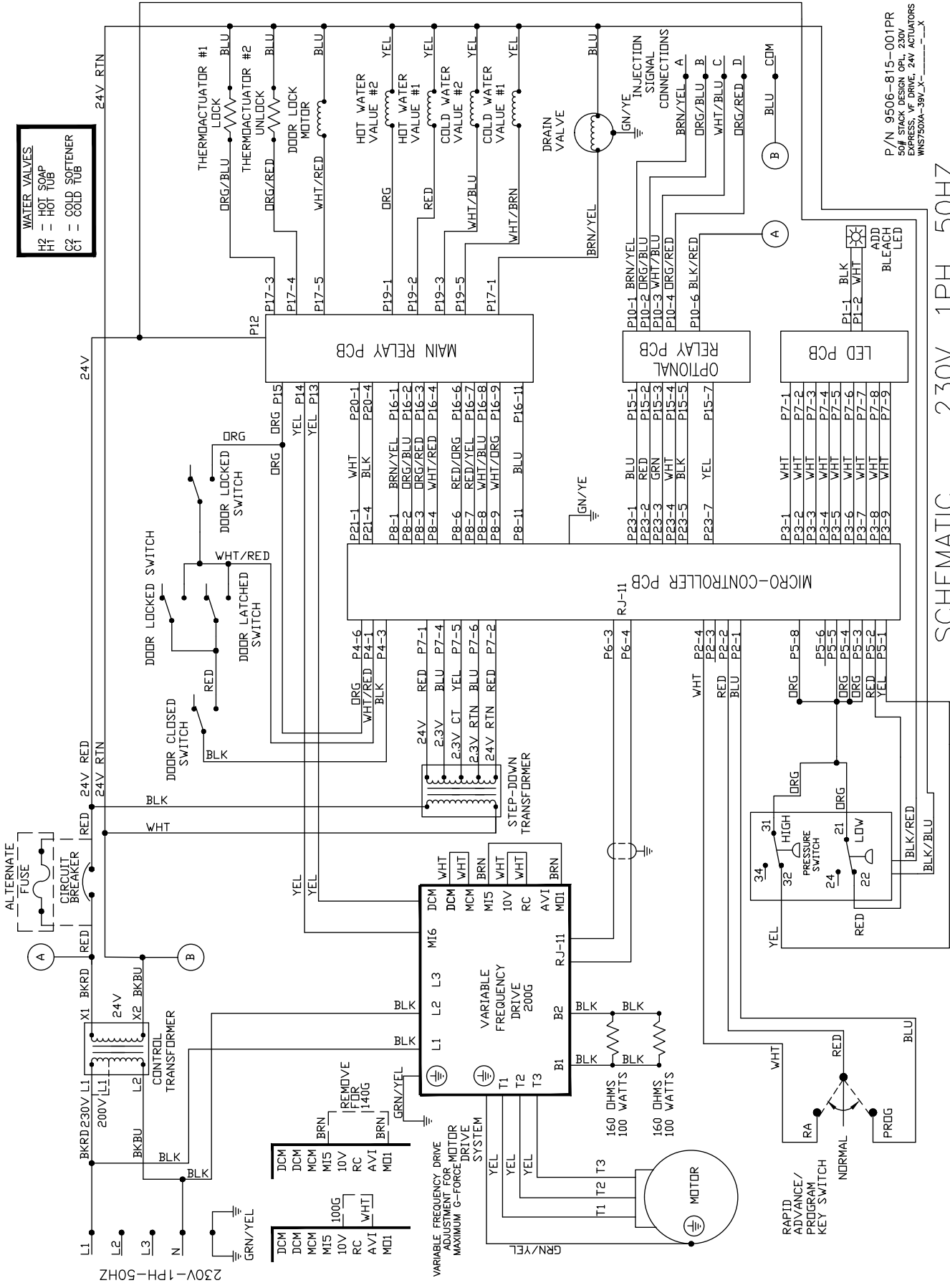

P/N 9506-815-001PR  
 50# STACK DESIGN OPL, 230V  
 EXPRESS, VF DRIVE, 24V ACTUATORS  
 WNS7500A-39V\_X

SCHEMATIC 230V, 1PH, 50HZ



# SWD T-750-39 Schematic V4

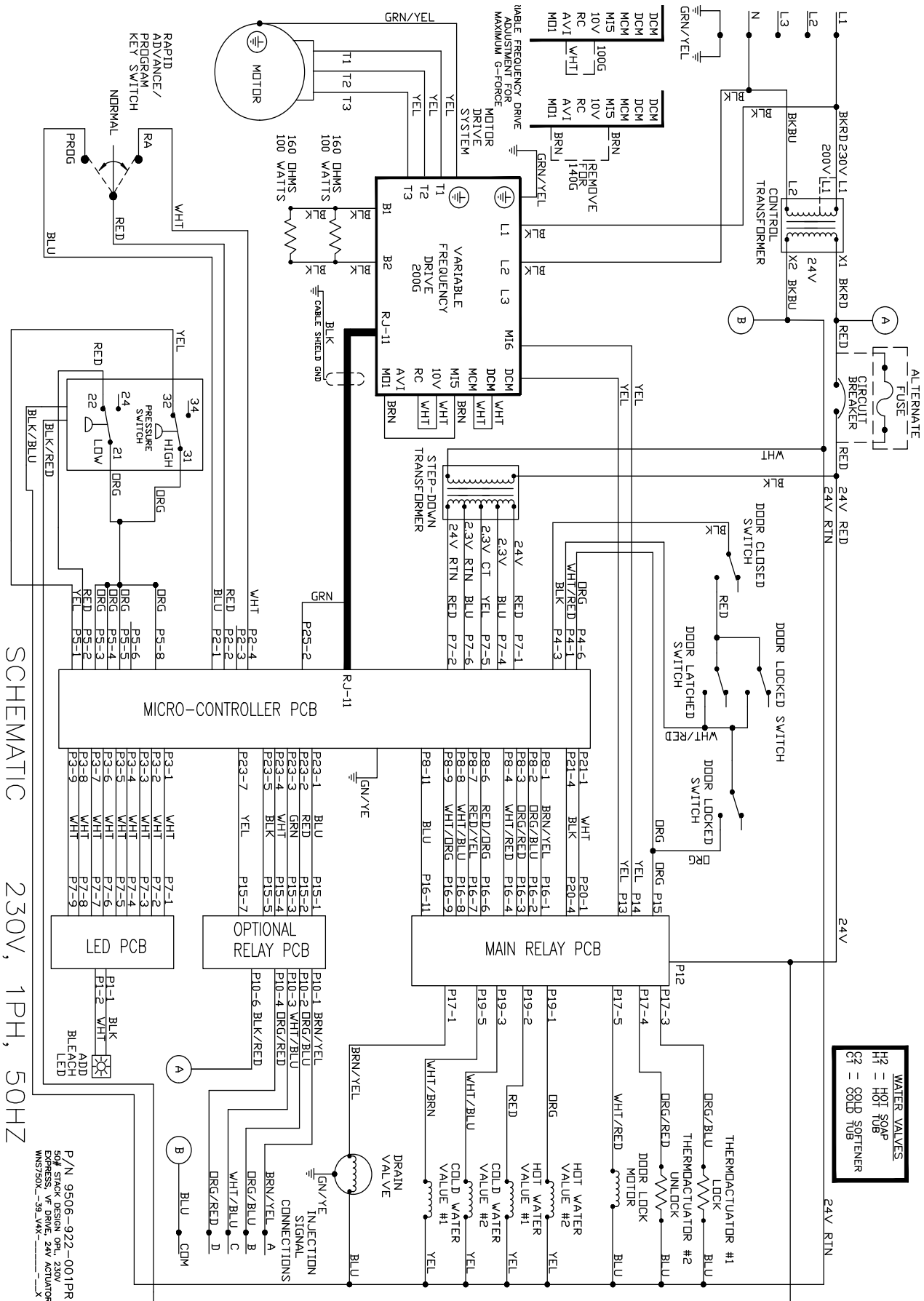



---

# **Section: 12**

Maintenance

Washer and Dryer

---

# Preventative Maintenance

## Daily

- Step 1:** Clean the lint screen free of lint and other debris. Use a soft brush and Hot water if necessary.
- Step 2:** Check the lint screen for tears. Replace if necessary.
- Step 3:** Clean lint from the lint screen compartment.
- Step 4:** Inspect felt seal on lint screen assembly, replace if needed.

## Monthly

- Step 1:** Remove lint accumulation from the end bells of the motor.
- Step 2:** Remove lint accumulation from front control area.
- Step 3:** Remove lint and dirt accumulation from the top of the dryer and all areas above, below, and around the burners and burner housing. Failure to keep this portion of the dryer clean can lead to a build-up of lint creating a fire hazard.
- Step 4:** Remove and clean coin acceptors. (Vended Models Only)

## Quarterly

- Step 1:** Check the belts for looseness, wear, or fraying.
- Step 2:** Inspect the gasket of the door glass for excessive wear.
- Step 3:** Check tightness of all fasteners holding parts to support channel.
- Step 4:** Check tightness of all set screws.
- Step 5:** Remove the air flow switch assembly and check the tumbler thru-bolts for tightness.
- Step 6:** Apply a few drops of oil to pivot pins and the tension arms where in contact with each other.

## Semi-Annually

- Step 1:** Remove and clean the main burners.
- Step 2:** Remove all orifices and examine for dirt and hole obstruction.
- Step 3:** Remove all lint accumulation. Remove the front panel and the lint screen housing and remove lint accumulation.

## Annually

- Step 1:** Check the intermediate pulley bearings for wear.
- Step 2:** Check and remove any lint accumulation from the exhaust system including recirculation chambers if applicable.
- Step 3:** Grease the bearings and the shaft of the intermediate pulley. Use an Alemite grease gun and Molykote BR2-S grease. (Where applicable)

---

# Preventative Maintenance

## Daily

- Step 1:** Check that the loading door remains securely locked and cannot be opened during an entire cycle.
- Step 2:** Clean the top, front, and sides of the cabinet to remove residue.
- Step 3:** Clean the soap dispenser and lid and check that all dispenser mounting screws are in-place and tight.
- Step 4:** Check the loading door for leaks. Clean the door seal of all foreign matter.
- Step 5:** Leave the loading door open to aerate the washer when not in use.

## Quarterly

- Step 1:** Make sure the washer is inoperative by switching off the main power supply.
- Step 2:** Check the V-belts for wear and proper tension.
- Step 3:** Clean lint and other foreign matter from around motor.
- Step 4:** Check all water connections for leaks.
- Step 5:** Check the drain valve for leaking and that it opens properly.
- Step 6:** Wipe and clean the inside of the washer and check that all electrical components are free of moisture and dust.
- Step 7:** Remove and clean water inlet hose filters. Replace if necessary.
- Step 8:** Check anchor bolts. Retighten if necessary.

