



DEXTER[®]
LAUNDRY

**USE THE BLUE TABS LOCATED ON THE
RIGHT AND LEFT SIDES OF THE FOLLOWING
DOCUMENT TO ADVANCE TO EACH SECTION.**

O-Series Accessories

T-350 WN0350XA-12EO1X 208-240 volts 60hz Single Phase or Three Phase
 T-450 WN0450XA-12EO1X 208-240-volts 60hz Single Phase or Three Phase

Key	Description	T-350	T-450	QTY
*	Kit, Door Gasket Expander (large)	9732-139-002	9732-139-002	1
*	Kit, Door Gasket Expander (small)	9732-139-001	9732-139-001	1
*	Hose, Water Supply 3/8" I.D. x 48"	9990-027-011	9990-027-011	2
*	Washer, Inlet Hose (furnished)	8641-242-000	8641-242-000	2
*	Strainer, Inlet Hose (furnished)	9565-003-001	9565-003-001	2
*	Bevel Washer for 5/8" bolt used in installations using angle iron bases	8641-586-002	8641-586-002	4
*	Sealing compound RTV-45	8538-151-002	8538-151-002	AR
*	Flow Restrictors (in dispenser)	9475-002-002	9475-002-002	2
*	OPL Bearing & Seal Kit	9732-219-008	9732-219-005	1
	USB, W/ owners booklets	9150-045-002	9150-045-002	1



Section 8:

Parts Data:

T-350 WN0350XA-12EO1X 208-240 volts 60hz Single Phase or Three Phase
 T-450 WN0450XA-12EO1X 208-240-volts 60hz Single Phase or Three Phase

Kits, Assemblies, & Common Parts

Description	T-350	T-450
Cylinder and Tub Back	9732-354-002	9732-354-004
Kit - Door Lock Assy. & Cam, replaces 9885-024-001	9732-347-001	9732-347-001
Kit - Door cam replacement	9732-346-002	9732-346-002
Kit - Locking Pawl replacement	9732-346-001	9732-346-001
Kit - 8650-012-003 Lock with spacer	9732-344-001	9732-344-001
Kit - 3" Drain valve seal replacement	9732-327-001	9732-327-001
Drain Valve 3"		9379-202-001
Drain Valve 2"	9379-199-001	
Water Valve (Dual)	9379-183-012	9379-183-012
Diaphragm	9118-049-003	9118-049-003
Cylinder Plug (1.5" Plastic)	9456-041-007	9456-041-007
Electronic Pressure Switch	9732-315-001	9732-315-001
Delta E Drive Display	9150-044-001	9150-044-001
Breaking Resistor 200 Ohms	9483-004-002	9483-004-002
Transformer	8711-017-001	8711-017-001
Main Control Board	9799-027-001	9799-027-001
Data Cable	9806-023-003	9806-023-003
Door Lock Gear Motor Assembly	9922-015-003	9922-015-003
Door Lock Latching Assembly	9885-031-001	9885-031-001
Door Handle Only	9244-091-001	9244-091-001
Front Panel Screw	9545-008-014	9545-008-014
Front Panel Finisher Washer	8641-585-001	8641-585-001
Front Panel Spring Nut	8640-442-001	8640-442-001
Soap Box Screw	9545-008-012	9545-008-012
Soap Box Spring Nut	8640-399-007	8640-399-007
5/16 Hex Screw	9545-008-026	9545-008-026
Belt	9040-079-004	9040-079-005
Key, Top- # 6324	6292-006-007	6292-006-007
Fuse Holder Assembly	9200-001-002	9200-001-002
Fuse, 2 Amp Slow, 1/4 x 1-1/4	8636-018-005	8636-018-005
Fuse, 1.5 Amp Fast, 1/4 x 1-1/4	8636-018-001	8636-018-001
Door Glass Gasket	9206-411-002	92406-419-001

Wiring Harness Part # by Model

Key	Description	T-350	T-450	QTY
*	Cable Assy. USB	9806-024-001	9806-024-001	1
*	Wiring Harness, Door Lock	9627-936-002	9627-936-002	1
*	Wire Assy. Blue 17"	8220-063-047	8220-063-047	1
*	Wire Assy. Blue / White 17"	8220-063-048	8220-063-048	1
*	Wiring Harness, Power Terminal Block	9627-932-002	9627-932-002	1
*	Wiring Harness, Injection	9627-935-002	9627-935-002	1
*	Wire Assy. Brown #21, 3"	8220-057-035	8220-057-035	1
*	Wire Assy. White 3"	8220-057-036	8220-057-036	1
*	Wire Assy. Black Jumper Braking Resistors	8220-117-002	8220-117-002	1
*	Data Cable	9806-023-003	9806-023-003	1
*	Wire Assy. White/Red Jumper Water Valves	8220-123-002	8220-123-002	1
*	Wiring Harness, 15-Pin Non-Injection	9627-934-002	9627-934-002	1

Cabinet and Front Panel Group Part # by Model

Key	Description	T-350	T-450	QTY
*	Panel, Side (Left or Right) - stainless		9732-359-007	2
*	Panel, Right Side-stainless	9989-640-001		1
*	Panel, Left Side - stainless	9989-640-002		1
*	Screw, (Side Panel to Base)	9545-018-018	9545-018-013	6
*	Nut, Hex 1/4-20 UNC	8640-414-006	8640-414-006	6
*	Pad-Foam, Side Panel	0904-904-001	0904-904-001	2
*	Bracket, Side Panel under front panel	9029-263-001	9029-263-001	1
*	Nut, Hex (to tub front)	8640-413-002	8640-413-002	2
*	Screw, #10B x 1/2	9545-008-026	9545-008-026	2
2	Panel, Control	9454-597-001	9989-598-001	1
*	Screw, Control Panel to Sides	9545-008-026	9545-008-026	4
3	Nameplate Decal, Control Panel (Black)	9412-241-001	9412-242-001	1
4	Button, Push	9035-063-001	9035-063-001	1
5	Panel Assy, Front	9989-612-003	9989-613-003	1
*	Trim Edge Protector	9578-092-005	9578-092-005	1
*	Label, Warning-Door Opening (Black)	8502-757-001	8502-757-001	1
*	Label, Warning-Door Risk of Injury (Black)	8502-759-001	8502-759-001	1
10	Door, Lower Service (includes handle & Rivits)	9960-286-001	9960-286-002	1
11	Handle (bumper guard)	9244-086-001	9244-086-002	1
*	Rivet	9491-009-003	9491-009-003	4
*	Washer, Finish	8641-585-001	8641-585-001	2
*	Nut, Spring	8640-442-001	8640-442-001	2
15	Lock, Top (w/Key)	8650-012-003	8650-012-003	1
*	Lock Spacer	9538-189-001	9538-189-001	1
*	Key, Top- # 6324	6292-006-007	6292-006-007	1
16	Bumper-Loading door	9051-055-001	9051-055-001	1



Rear View Access Part # by Model

Key	Description	T-350	T-450	QTY
1	Drive Motor	9376-307-001	9376-319-001	1
2	Pulley, Motor	9453-180-001	9453-181-001	1
*	Set Screw,Sq.Hd(motor pulley)	9545-028-015	9545-028-015	2
3	Rod, Motor Mtg	9497-222-002	9497-222-002	1
*	Screw (end of motor rod)	9545-029-005	9545-029-005	1
*	Lockwasher (end of motor rod)	8641-582-014	8641-582-014	1
4	Motor Bushing (Rubber)	9053-082-001	9053-082-001	2
5	Clamp-Worm, 316SS, 1.5"	8654-117-019	8654-117-019	2
6	Strap Bracket, Motor Tension	9029-206-001	9029-206-002	1
*	Nut, Strap to Motor 10/32 UNF	8640-413-002	8640-413-002	1
*	Washer #10	8641-581-006	8641-581-006	1
7	Spring, Belt Tension	9534-319-002	9534-319-002	1
8	Pulley, Driven	9453-168-005	9453-168-006	1
*	Tolerance Ring (Driven Pulley)	9487-234-001	9487-234-003	1
9	Screw 1/2-13x1 1/4"	9545-017-009		1
9	Screw 5/8-11x1 1/2" Driven pulley		9545-060-001	1
10	Lockwasher 1/2"	8641-582-016		1
10	Lockwasher 5/8"		8641-582-018	1
11	Washer, Flat 1/2"	8641-581-026		1
11	Washer, Flat 5/8x2 1/4"		8641-581-032	1
12	Drive Belt	9040-079-004	9040-079-005	1
17	Hose, Overflow Suds, 11"	9242-463-002	9242-463-003	1
*	Clamp, Hose Vent	8654-117-008	8654-117-008	1
13	Hose, Overflow to drain	9242-449-002	9242-449-002	1
*	Clamp, Hose overflow to drain	8654-117-018	8654-117-018	2
14	Hose, Pressure Switch	9242-175-000	9242-175-007	1
*	Clamp, Pressure Switch Hose	8654-117-015	8654-117-015	1
*	Vacuum Breaker Mtg Bracket	9029-266-001	9029-077-001	1
*	Vacuum Breaker ALL	9610-001-001	9610-001-001	1
*	Clamp, Hose to Vacuum Breaker	8654-117-014	8654-117-014	1
*	Hose, Vacuum Breaker to tub	9242-458-001		1
*	Hose, Vacuum Breaker to Injector		9242-461-001	1
*	Clamps	8654-117-014	8654-117-014	1
15	Injector Assembly, Soap		9883-010-001	1
*	Hose, Injector to Tub Back		9242-462-001	1
*	Clamp		8654-117-014	1
16	Cap-Injector Assy		0935-127-001	1
*	Clamp		9242-117-008	1
*	Panel Assy., Back	9454-632-001	9989-562-001	1
*	Screw Panel Mtg.#10Bx1/2"	9545-008-026	9545-008-026	10
*	Nut, Spring	8640-399-004	8640-399-004	6
*	Screw, To Base-1/4x3/4		9545-030-002	1

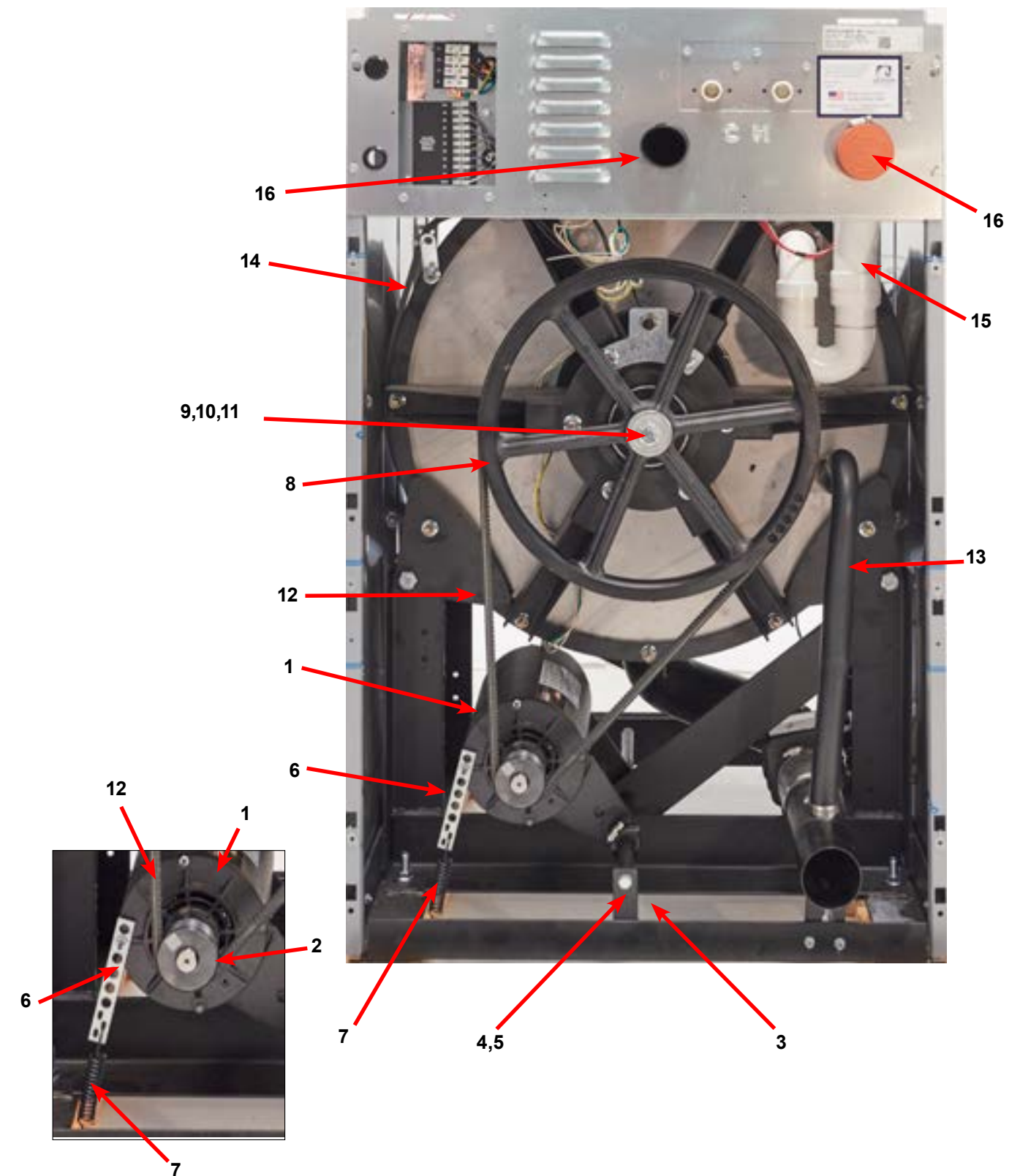

Key	Description	T-350	T-450	QTY
1	Channel, Rear	9947-025-001	9947-026-001	1
2	Screw #10Bx1/2	9545-008-026	9545-008-026	4
*	Nut, Spring	8640-399-007	8640-399-007	4
3	Plug, 7/8"	9456-041-006		1
4	Bushing, 7/8"	9053-067-002		1
5	Bracket-Terminal Block Assy	9029-265-001	9029-265-001	1
6	Screw, 10Bx1/2	9545-008-026	9545-008-026	4
7	Strip-Terminal marker, Power	9558-025-001	9558-025-001	1
8	Terminal Block-Power	9897-033-002	9897-033-002	1
*	Screw-6ABx3/4	9545-031-010	9545-031-010	2
9	Harness-Power Terminal Block	9627-932-002	9627-932-002	1
10	Terrminal Lug, Solderless	8652-134-001	8652-134-001	1
*	Lockwasher #10	8641-582-006	8641-582-006	1
11	Screw-10-32ttX1x1/2 GRN	9545-008-027	9545-008-027	2
12	Strip-Terminal Marking, Injector, 11 position	9558-036-001	9558-036-001	1
13	Terminal Block-Injector	9897-032-003	9897-032-003	1
*	Screw-4Bx5/8ss	9545-053-002	9545-053-002	2
14	Harness-Injection	9627-935-002	9627-935-002	1
15	Label-Warning	8502-639-001	8502-639-001	1
16	Bushing-Insulated, 3/4"	9053-067-001	9053-067-001	1
17	Bushing-Insulated, 1"	9053-067-004	9053-067-004	1
*	Cover, Terminal Block	9074-267-001	9074-267-001	1
*	Screw #10Bx1/2	9545-008-026	9545-008-026	1
18	Plate Drive Mounting	9982-382-001	9982-383-001	1
19	Nut-#10-32UNF, 2B	8640-413-002	8640-413-002	4
20	VFD Delta "E" drive 208-240 volt	9375-032-015	9375-030-019	1
*	Cable, Data	9806-023-003	9806-023-003	1
*	VFD Cooling Fan	9189-013-001	9189-013-001	1
*	VFD, MS300, O2	9375-034-015	9375-035-016	1
*	VFD Cooling Fan	9189-015-001	9189-016-001	1
21	Nut-#10-32UNF 2B	8640-413-002	8640-413-002	4
22	Mounting Plate Water Valves	9452-813-001	9452-813-001	1
23	Nut-Elastic stop, #10-32	8640-413-002	8640-413-002	2
24	Valve-Water, Duel Coil	9379-183-012	9379-183-012	2
25	Screw #10Bx1/2	9545-008-026	9545-008-026	4
26	Shield over Water Valves Plastic	9550-194-001	9550-194-001	1
27	Push Clip	9083-121-001	9083-121-001	3
28	Vacuum Breaker	9610-001-001	9610-001-001	1
*	Bracket-Vacuum Breaker	9029-266-001	9029-077-001	1
*	Vacuum Breaker Cap (Red)	0935-135-002	0935-135-002	
29	Screw, 10Bx1/2	9545-008-026	9545-008-026	4
30	Cap-Injector Assy		0935-127-001	1
*	Clamp		9242-117-008	1
31	Hose, Vacuum Breaker to Injector		9242-461-001	1
32	Clamps		8654-117-014	1
33	Hose-Suds Overflow	9242-463-002	9242-463-003	1
34	Braking resistors (200 ohm)	9483-004-002	9483-004-002	2
35	Screw-#10Bx1/2	9545-008-026	9545-008-026	4

Rear View Access Part # by Model Continued

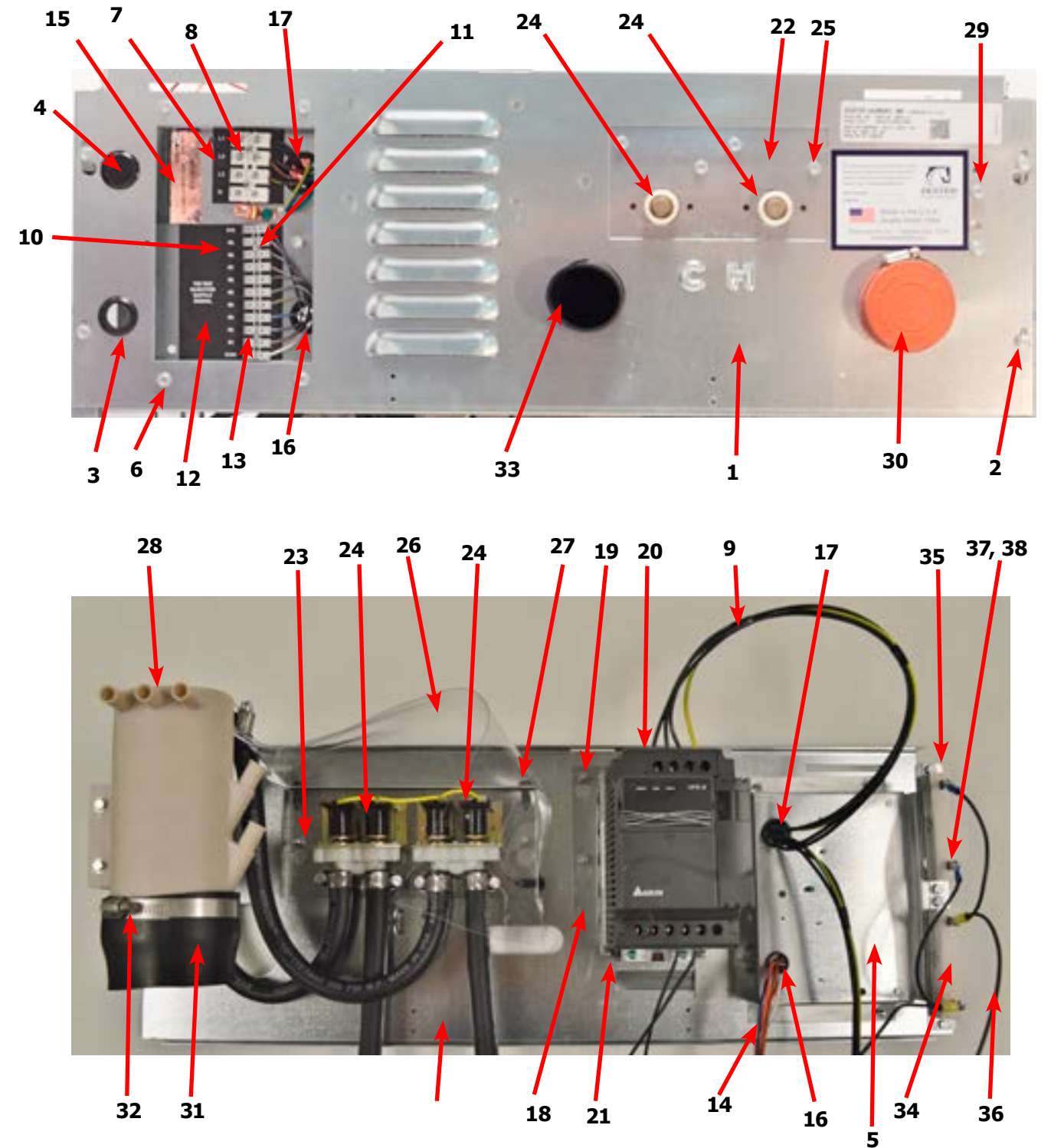

Cylinder, Seals & Bearings Part # by Model

Key	Description	T-350	T-450	QTY
*	Bearings and Seal Kit	9732-219-008	9732-219-005	1
*	Housing, Bearing- Assembly (items #2-#6)	9803-179-003	9803-186-001	1
2	Housing, Bearing	9241-169-002	9241-180-002	1
3	Bearing, Front (LARGE)	9036-159-009	9036-159-005	1
4	Bearing, Rear (SMALL)	9036-159-008	9036-159-004	1
5	Spacer, Bearing	9538-158-001	9538-167-001	1
6	Ring, Bearing Retainer	9487-238-001	9487-238-003	1
7	Tub Back Mating Ring	9487-261-002	9487-261-003	1
8	Seal, Large	9532-140-009	9532-140-009	1
9	Seal, Small	9532-140-003	9532-140-006	1
10	Ring, Seal Mounting	9950-042-001	9950-048-001	1
11	Back Assy, Tub 2 piece	9962-016-001	9962-013-002	1
12	Bolt, Tub End of Bearing Housing (1/2" x 1 1/4")	9545-017-009		6
12	Nut 1/2'	8640-417-005		6
12	Flat washer 1/2"	8641-581-034		6
12	Bolt 7/16-14x1 1/2" Tub end of bearing housing		9545-059-003	6
12	Nut 5/8"		8640-425-001	6
13	Support Arm Assy, Bearing Housing	9991-057-002	9991-056-002	6
*	Tub Alignment Spacer	9552-038-003	9552-038-003	
14	Bolt Pulley End of Bearing Housing (3/8" x 1 1/2")	9545-029-003		6
14	Nut, Flange Locking 3/8"	8640-415-004		6
14	Bolt Pulley end of bearing housing (7/16-14x2")		9545-059-002	6
14	Nut, Flange Locking 7/16"		8640-416-005	6
15	Pulley, Driven	9453-168-005	9453-168-006	1
*	Ring, Tolerance	9487-234-001	9487-234-003	1
16	Washer 1/2"	8641-581-026		1
16	Washer 5/8"		8641-581-032	1
18	Bolt 1/2-13 x 1 1/4"	9545-017-009		1
18	Bolt 5/8-11x1 1/2"		9545-060-001	1
20	Lockwasher 1/2" Ext. tooth	8641-582-016		1
18	Lockwasher 5/8 Ext. tooth		8641-582-018	1
*	Cylinder Assy Before Serial # W1.20190.XXX	9732-354-002	9732-354-004	1
*	Cylinder Assy After Serial # W1.20190.XXX	9848-164-001	9848-166-001	1
*	Tub and Cylinder Assy.	9869-029-001	9869-031-001	1
*	Tub Assembly	9930-160-001	9930-162-001	1

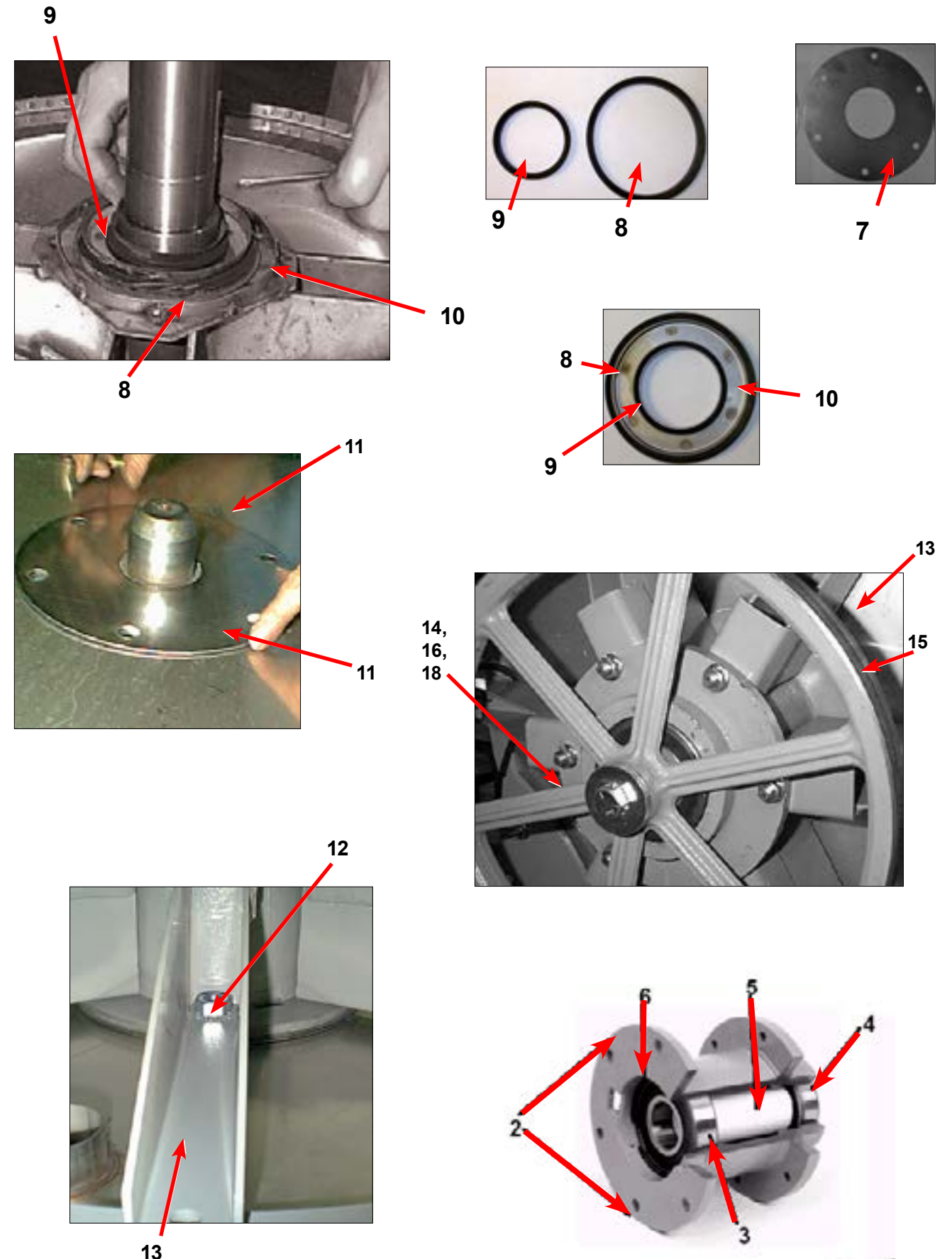

Door Lock Assembly (All Models)

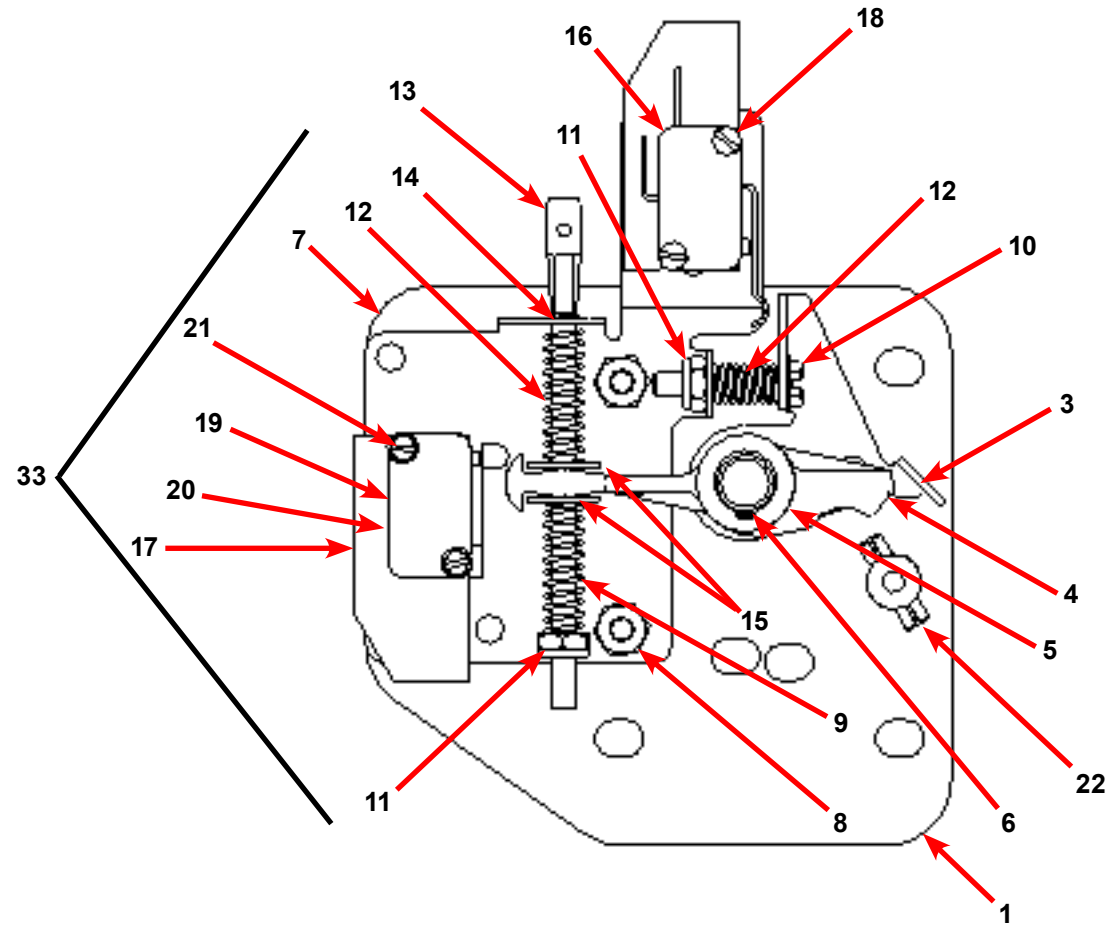

Key	Description	All Models	QTY
*	Lock Assy, Complete (#1-22) (includes #1 thru #22)	9885-031-001	1
1	Plate Assy, Door Lock	9982-346-001	1
2	Washer, Flat (SS or Brass)	8641-581-030	1
3	Actuator, Latching Switch	9008-005-001	1
4	Pawl, Locking	9732-346-002	1
5	Washer, Spring	8641-569-003	1
6	Ring, Retaining	9487-200-004	1
7	Bracket Switch	9029-163-001	1
8	Nut, Hex 10-32 UNF	8640-413-002	2
9	Spring, Actuating	9534-364-002	1
10	Screw, Hx. 10-32 x 1"	9545-012-020	1
11	Nut, Elastic Stop 10-32	8640-413-004	2
12	Spring, Return	9534-364-001	2
13	Pin, Guide	9451-193-001	1

Key	Description	All Models	QTY
14	Ring, Retaining	9487-200-005	1
15	Washer	8641-581-031	1
16	Switch, Latching Sensing	9539-461-008	1
17	Shield, Switch	9550-169-003	3
18	Screw 4-40 x 5/8"	9545-020-001	2
18	Nut, Twin 4-40	8640-401-001	1
19	Switch, Locking Sensing	9539-461-007	2
20	Actuator, Switch Locking	9008-006-003	1
21	Screw 4-40 x 1 1/8"	9545-020-003	2
21	Nut, Twin 4-40	8640-401-001	1
*	Spacer Sensor	9538-182-001	*
22	Pin, Dowel (for door cam)	9451-181-004	1
*	Shim, Door Lock, Thin	9552-037-001	AR
*	Screw, Lock mtg 1/4"-20 x 3/4"	9545-018-014	3
*	Lockwasher 1/4" Ext tooth	8641-582-007	3
*	Door Stud Pin, 3/16" x 3/4"	9451-181-004	1

Gear Motor Door Lock Assembly

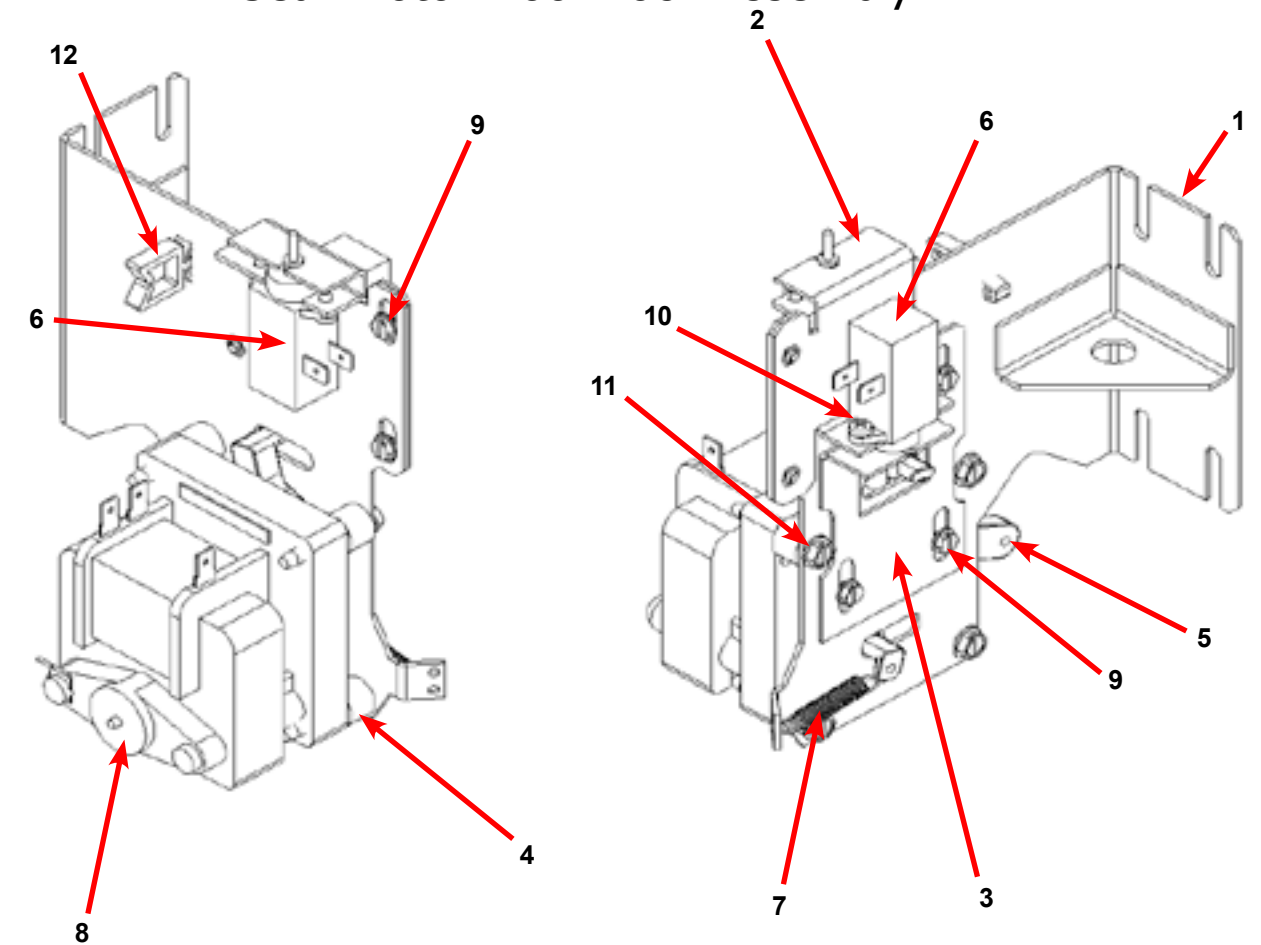

Key	Description	T-350	T-450	QTY
*	Actuator Assembly (Includes 1-10, Rod NOT included)	9892-015-003	9892-015-003	1
1	Bracket Assy, Slide Lock Actuator	9985-190-001	9985-190-001	1
2	Bracket Assy, Slide - Unlock	9985-189-001	9985-189-001	1
3	Bracket Slide Lock	9029-204-001	9029-204-001	1
4	Spacer, Plastic	9538-157-021	9538-157-021	4
5	Arm - Door Lock	9001-063-001	9001-063-001	1
6	Thermoactuator - 24VAC	9586-001-003	9586-001-003	2
7	Spring - Extension	9534-350-001	9534-350-001	1
8	Motor & Gear Assembly 120 VAC	9914-137-015	9914-137-015	1
9	Screw -Hxwshrdsls, 6-32 x 3/16	9545-044-003	9545-044-003	6
10	Cross Recessed PAn Hd Tapping screw	9545-031-011	9545-031-011	4
11	Screw - hxwshdsl, 10-24 - 1.25f, ctd	9545-046-007	9545-046-007	4
12	Standoff-Wire	9527-007-001	9527-007-001	1
*	Rod, Door Lock	9497-225-011	9497-225-012	1

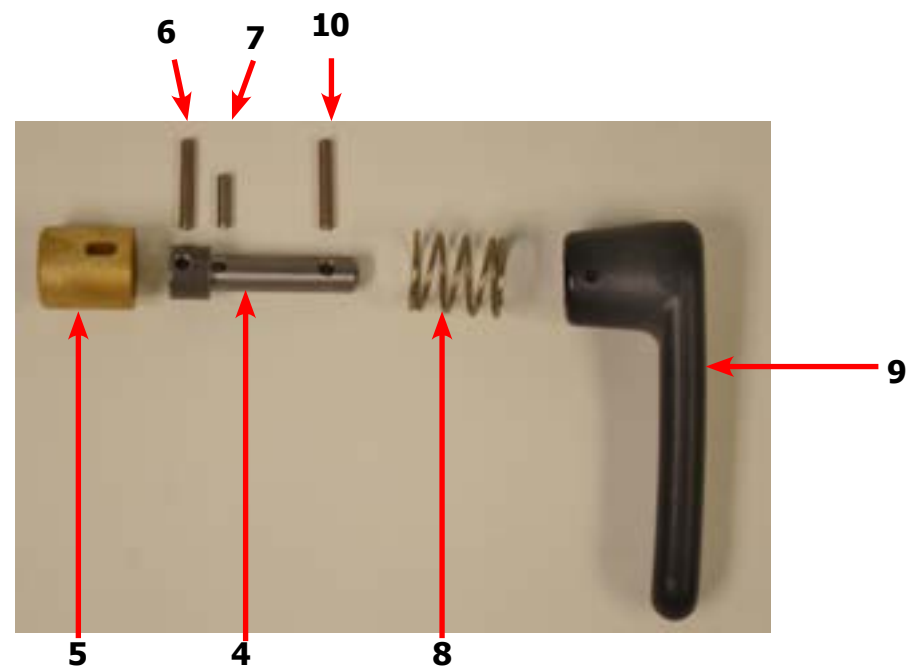
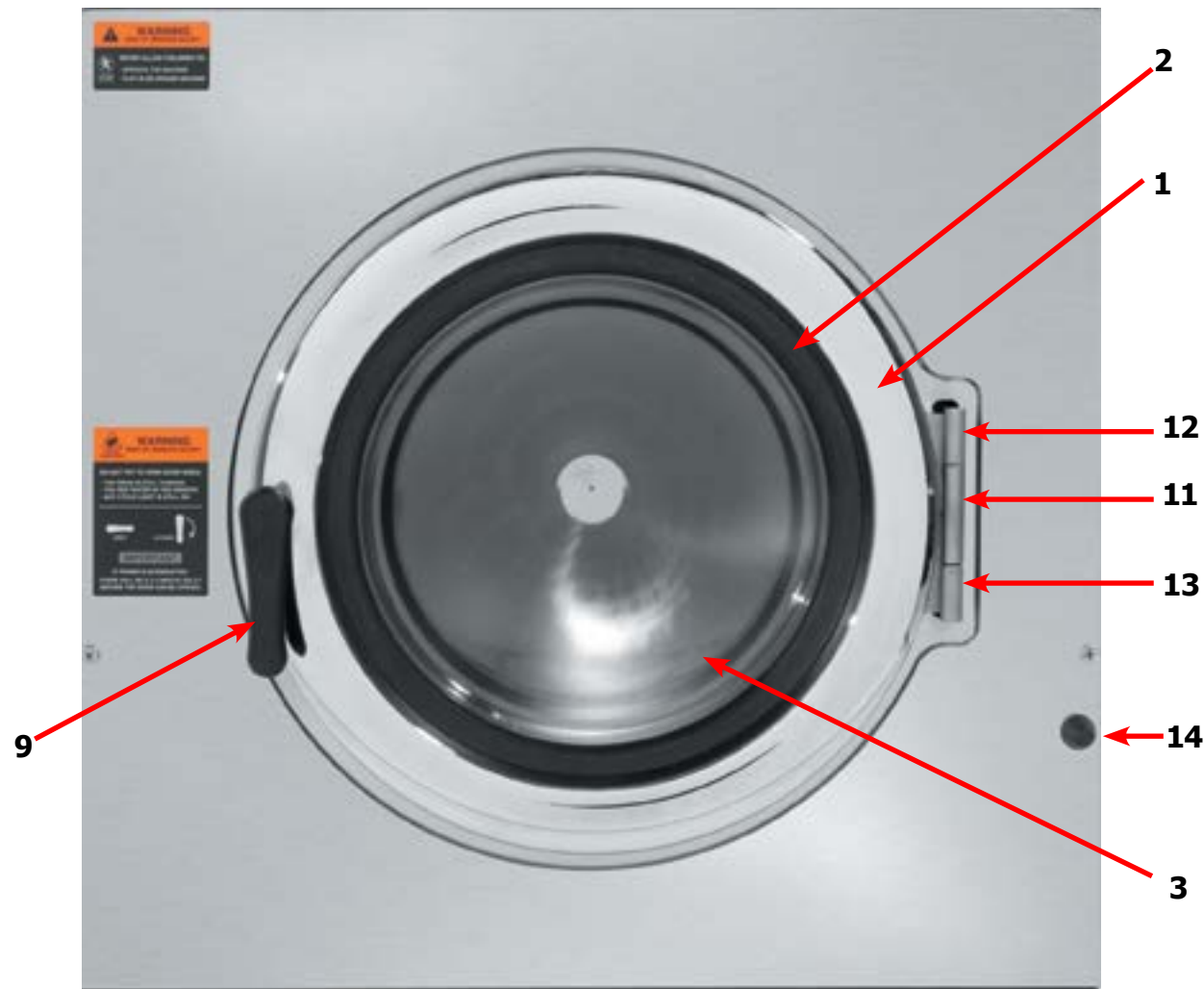

Loading Door Part # by Model

Key	Description	T-350	T-450	QTY
*	Loading Door, Complete #1-10	9960-308-001	9960-309-001	1
1	Loading Door, Ring	9487-264-002	9487-265-002	1
2	Gasket, Loading Door	9206-411-002	9206-419-001	1
3	Window, Loading Door	9635-018-001	9635-016-001	1
*	Shaft Assy, Locking (includes 4 thru 7)	9913-136-001	9913-136-001	1
4	Shaft, Door Locking	9537-195-002	9537-195-002	1
5	Cam, Locking	9095-051-001	9095-051-001	1
6	Pin, Groove (1 1/4)	9451-181-005	9451-181-005	1
7	Pin, Groove (3/4)	9451-181-004	9451-181-004	1
8	Spring, Lock Cam	9534-360-002	9534-360-002	1
9	Handle, Door	9244-091-001	9244-091-001	1
10	Pin, Door Handle (groove)	9451-181-005	9451-181-005	1
11	Door Hinge Assembly Mounts to Tub Front	9955-030-001	9955-030-001	
*	Shim, Loading Door Hinge (Thin)	9552-036-001	9552-036-001	2
*	Screw, 5/16-18x3/4	9545-014-009	9545-014-009	3
*	Lock Washer, 5/16	8641-582-009	8641-582-009	3
12	Leaf Assembly-Hinge, Top	9845-008-001	9845-008-001	1
13	Leaf Assembly-Hinge, Bottom	9845-005-002	9845-005-002	1
*	Screw, 5/16x5/8	9545-056-002	9545-056-002	3
14	Bumper-Loading Door	9051-055-001	9051-055-001	1
*	Nut, 1/4, 20UNC, 2B	8640-414-003	8640-414-003	1
15	Label, Warning-Door Opening (Black)	8502-757-001	8502-757-001	1
16	Label, Warning-Door Risk of Injury (Black)	8502-759-001	8502-759-001	

Loading Door Hinge 180 Degree Opening

Key	Description	T-350	T-450	QTY
1	Door Hinge Assembly (mounts to tub front)	9955-030-001	9955-030-001	1
*	Shim, Loading Door Hinge (Thin)	9552-036-001	9552-036-001	2
*	Screw, 5/16-18x3/4	9545-014-009	9545-014-009	3
*	Lock Washer, 5/16	8641-582-009	8641-582-009	3
2	Leaf Assembly-Hinge, Top	9845-008-001	9845-008-001	1
3	Leaf Assembly-Hinge, Bottom	9845-005-002	9845-005-002	1
4	Screw, 5/16x5/8	9545-056-002	9545-056-002	3
5	Switch, Door Hinge Close (Plunger)	9539-492-001	9539-492-001	1
6	Door Ring	9487-264-002	9487-265-002	1
7	Gasket, Door Glass	9206-411-002	9206-419-001	1
8	Window, Cloths	9635-018-001	9635-016-001	1
*	Bumper-Loading Door	9051-055-001	9051-055-001	1
*	Nut, 1/4, 20UNC, 2B	8640-414-003	8640-414-003	1

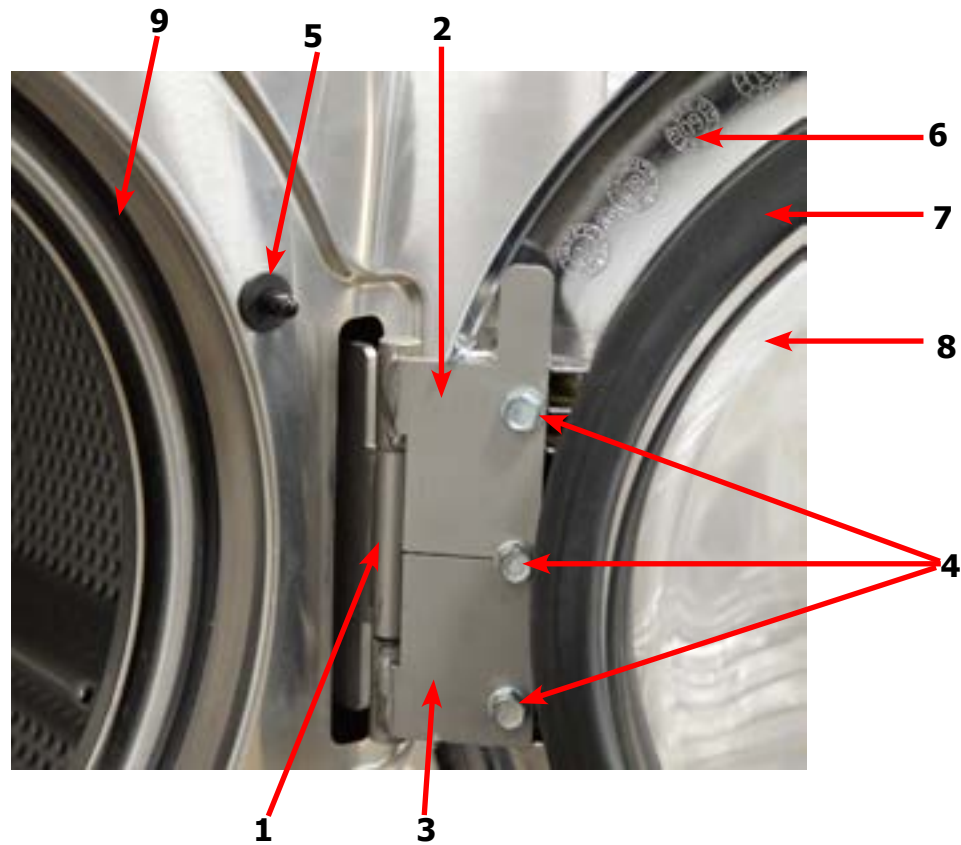

Water Inlet Valve Breakdown Part # by Model

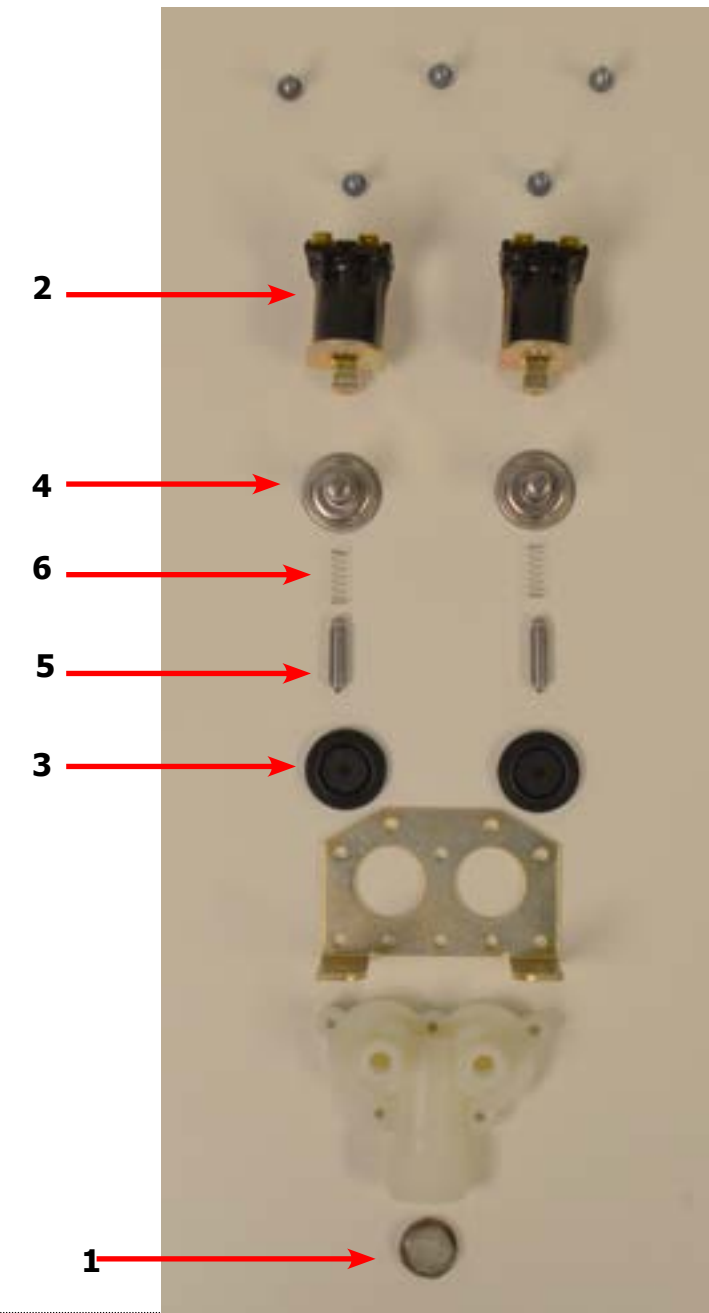

Key	Description	T-350	T-450	QTY
*	Valve, Water Inlet (includes 1 thru 6)	9379-183-012	9379-183-012	2
1	Screen, Inlet end of valve	9555-056-001	9555-056-001	2
2	Coil Assy., 120 V Invensys	9089-017-001	9089-017-001	2
*	Diaphragm Invensys (EPDM)	9118-049-001	9118-049-001	2
*	Diaphragm Invensys (Viton)	9118-049-002	9118-049-002	2
3	Diaphragm Invensys (EPDM NSF)	9118-049-003	9118-049-003	2
4	Guide, Solenoid Invensys	9211-021-002	9211-021-002	2
5	Armature Invensys	9015-008-001	9015-008-001	2
6	Spring, Armature Invensys	9534-298-001	9534-298-001	2

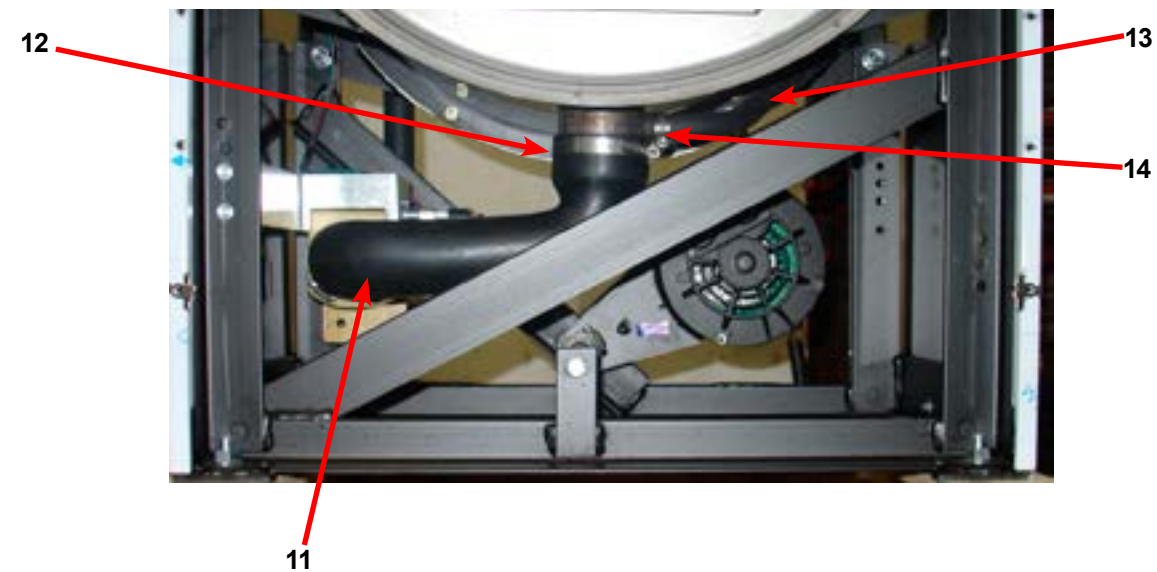
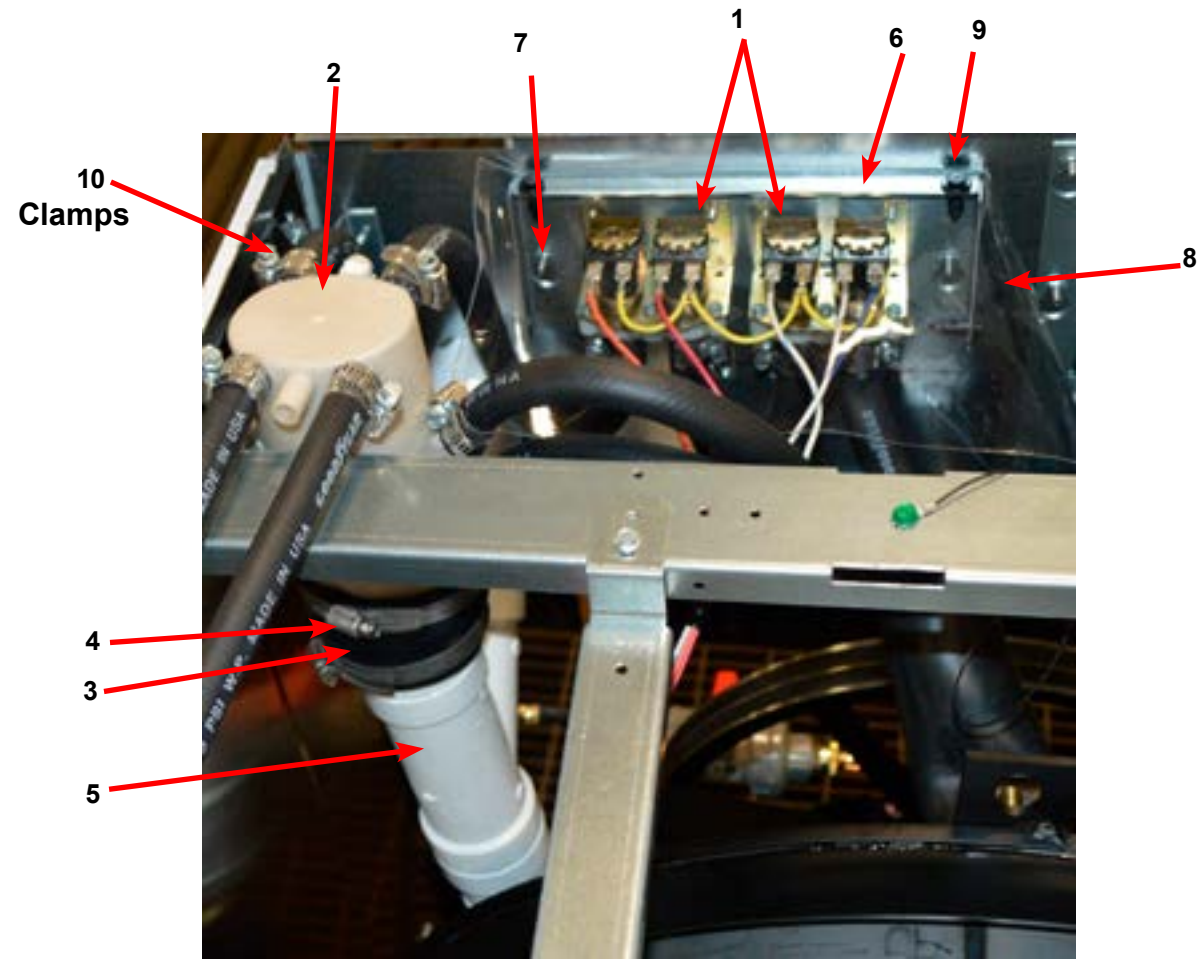

Water Inlet Part # by Model

Key	Description	T-350	T-450	QTY
1	Valve, Water Inlet (dual outlet) (see Water Inlet Valve Breakdown for individual parts)	9379-183-012	9379-183-012	2
*	Screw, Valve Mtg	9545-008-026	9545-008-026	4
2	Vacuum Breaker	9610-001-001	9610-001-001	1
*	Bracket, Vacuum Breaker	9029-266-001	9029-077-001	1
*	Screw	9545-008-026	9545-008-026	4
*	Hose, Vacuum Breaker to Tub	9242-458-001		1
*	Clamp, Tub End	8654-117-014		2
3	Hose, Vacuum Breaker to Injector		9242-461-001	1
4	Clamps		8654-117-014	1
5	Injector Assembly, Soap		9883-010-001	1
*	Hose, Injector to Tub Back		9242-462-001	1
*	Clamps		8654-117-014	1
*	Cap-Injector Assy		0935-127-001	1
*	Clamp		9242-117-014	1
6	Plate-Water Valves	9452-813-001	9452-813-001	1
7	Nut-Elastic stop, #10-32	8640-413-002	8640-413-002	2
8	Shield over Water Valves Plastic	9550-194-001	9550-194-001	1
9	Clip Push on	9083-121-001	9083-121-001	2
*	Hose, Bulk 1/2" I.D.	9242-453-001	9242-453-001	AR
10	Clamp, Hose-Worm	8654-117-015	8654-117-015	12
*	Flow restrictor	9475-002-002	9475-002-002	2
*	Dispenser, Soap	9122-005-004	9122-005-004	1
*	Gasket, Dispenser	9206-416-001	9206-416-001	1
*	Nut, Spring-SS	8640-399-007	8640-399-007	4
*	Screw, Disp. Mtg	9545-008-012	9545-008-012	4
11	Hose Tub to Drain Valve	9242-468-001	9242-456-001	1
12	Clamp	8654-117-014	8654-117-014	1
13	Hose, Pressure Switch	9242-175-000	9242-175-007	1
14	Clamp, Pressure Switch Hose	8654-117-015	8654-117-015	1

Chassis and Drain Part # by Model

Key	Description	T-350	T-450	QTY
1	Base Assy,Frame	9945-119-002	9945-141-002	1
2	Outer Tub Assy	9930-160-001	9930-122-001	1
*	Tub & Cylinder Assy	9869-029-001	9869-031-001	1
3	Ring Assy, Tub Mtg-Front	9950-057-002	9950-051-004	1
4	Ring Assy.Clamp Tub Mtg.- Rear	9950-046-002	9950-056-002	1
5	Bolt, 1/2" x 1 1/4 Rings to Base	9545-017-012		4
6	Nut, Wizlock, 1/2-13	8640-417-005	8640-417-005	1
7	Hose, Tub to Drain Valve	9242-468-001	9242-456-001	1
8	Clamp, Hose (Tub to Drain Valve)	8654-117-014	8654-117-014	2
9	Valve, Drain	9379-199-001	9379-202-001	1
10	Hose, Drain Valve to Tube	9242-451-002	9242-457-001	1
11	Clamp, Hose (Drain Valve to Tube)	8654-117-014	8654-117-014	2
12	Bracket, Drain Valve	9029-005-001		1
*	Screw, Valve to Bracket 12ABx1/2	9545-008-026		2
13	Tube Assy, Drain	9915-125-002	9915-119-002	1
*	Screw Tube (Bracket to Base 1/4Bx3/4	9545-030-002	9545-030-002	2
14	Hose, Overflow to drain	9242-449-002	9242-449-002	1
*	Clamp, Overflow	8654-117-018	8654-117-018	2
*	Shim, Support Assembly (thin)	9552-038-003	9552-036-001	AR
15	Injection Tube		9883-010-001	1
*	Hose-Inlet, Water	9242-458-001		1
16	Dispenser Soap	9122-005-004	9122-005-004	1
17	Gasket, Dispenser	9206-416-001	9206-416-001	1
*	Nut Spring SS	8640-399-007	8640-399-007	4
*	Screw, Disp. Mtg	9545-008-012	9545-008-012	4
*	Hose, Dispenser to Tub	9242-450-002	9242-450-002	1
*	Clamp, Dispenser Hose	8654-117-008	8654-117-008	2
18	Back Ass'y, Tub	9962-016-001	9962-013-002	1

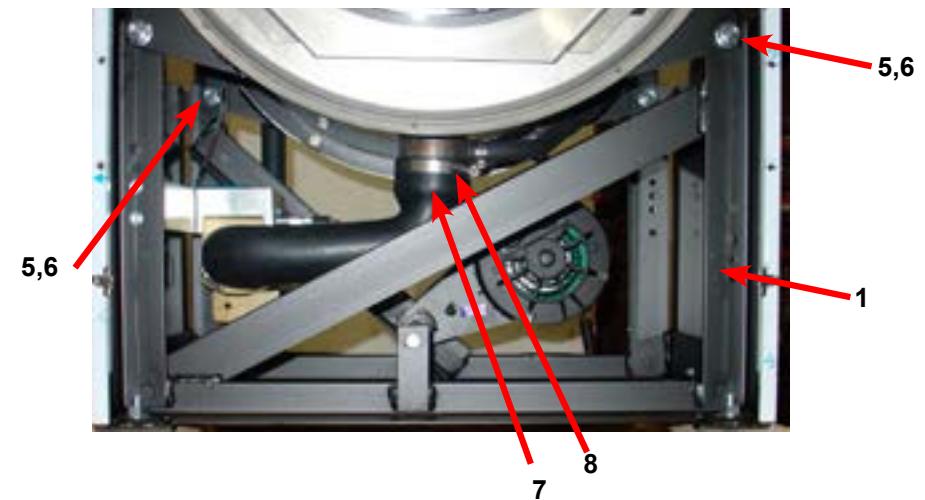
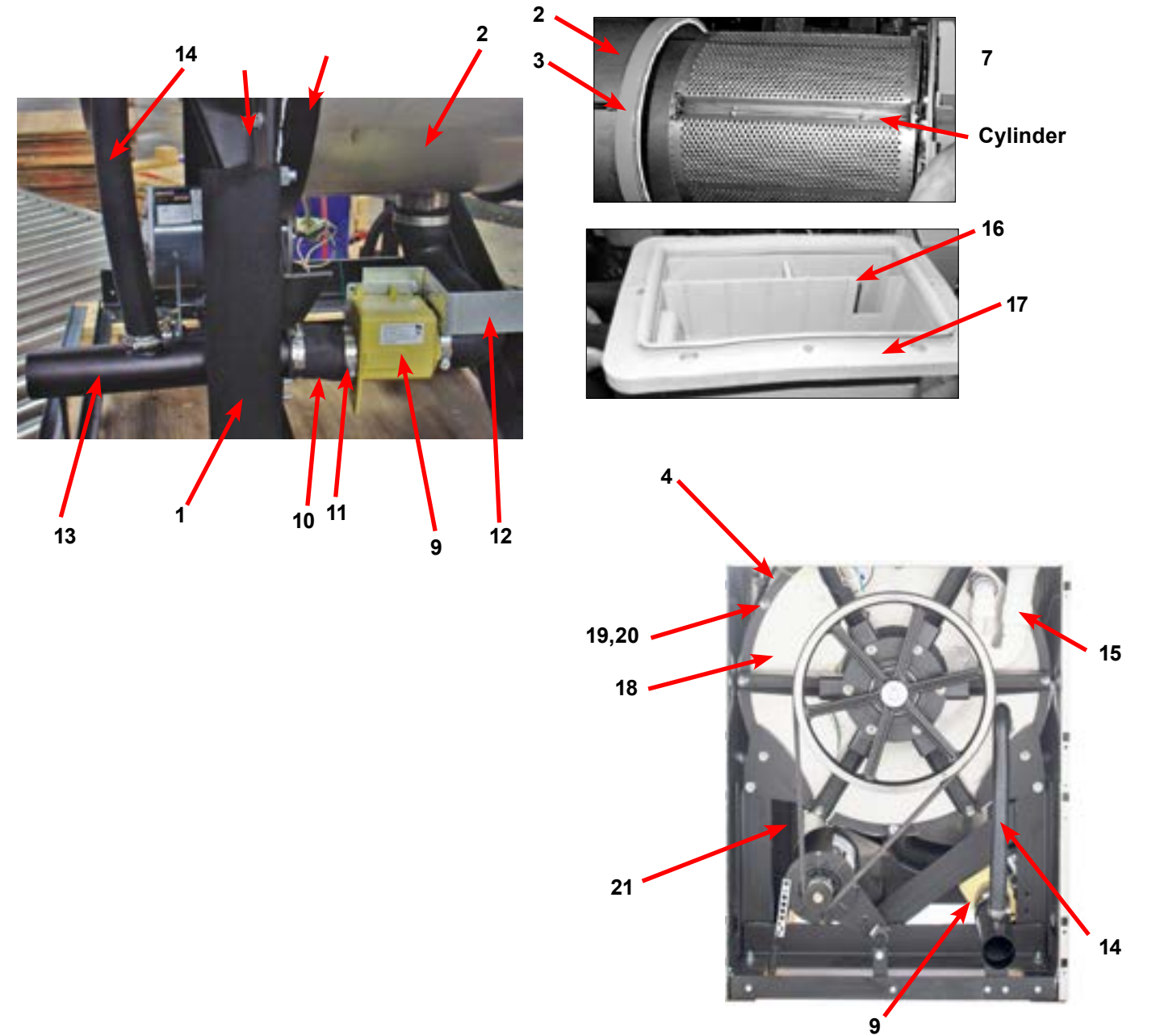

Electrical Components - Top Compartment 208/240VAC

Key	Description	T-350	T-450	QTY
*	Control Trough Assembly	9857-241-001	9857-242-001	1
1	Trough Assembly	9839-020-001	9839-020-001	1
2	Transformer, Dual Secondary	8711-017-001	8711-017-001	1
*	Screw, #10B x 1/2	9545-008-026	9545-008-026	4
*	Lockwasher #10	8641-582-006	8641-582-006	4
3	Terminal Block, Power	9897-026-005	9897-026-005	2
*	Screw, #8AB x 1/2	9545-045-012	9545-045-012	4
4	Wiring harness, Graphic Control	9627-922-002	9627-922-002	1
5	PCB Assembly, Main Control	9799-027-001	9799-027-001	1
6	PCB Assembly, Relay	9799-028-001	9799-028-001	2
*	Screw, #10B x 1/2	9545-008-026	9545-008-026	12
7	Wiring Harness, Main	9627-933-002	9627-933-002	1
8	Wiring Harness, Chemical Injection	9627-927-001	9627-927-001	1
9	Wire Assembly, Model Designator	8220-158-005	8220-158-011	1
10	Wiring Harness, VFD	9627-928-002	9627-928-002	1
*	Cable Clamp, 3/16"	8654-125-005	8654-125-005	1
*	Screw, 8B x 1/4"	9545-045-001	9545-045-001	1
11	Wiring Harness, Control / Relay	9627-921-001	9627-921-001	2
*	Wire Assembly, Relay PCB	8220-159-005	8220-159-005	1
*	Wire Assembly, Relay PCB	8220-159-006	8220-159-006	1
*	Screw, 10-32T x 1/2 Green	9545-008-027	9545-008-027	2
*	Lockwasher #10	8641-582-006	8641-582-006	2
*	Standoff, Twist lock	9527-002-002	9527-002-002	4
14	Pressure Switch	9732-315-001	9732-315-001	1
*	PCB Support, 3/8"	9548-285-001	9545-285-001	4
15	Wiring Harness, Pressure Switch	9627-926-002	9627-926-002	1
16	Wire Assembly, Orange 7-1/2"	8220-062-052	8220-062-052	1
17	Wire Assembly, White / Orange 9"	8220-062-053	8220-062-053	1
18	Fuse Holder Assembly	9200-001-002	9200-001-002	2
19	Fuse, 2 Amp Slow, 1/4 x 1-1/4	8636-018-005	8636-018-005	1
20	Fuse, 1.5 Amp Fast, 1/4 x 1-1/4	8636-018-001	8636-018-001	1
*	Label, Fuse 2.5 Amp	8502-716-002	8502-716-002	1
*	Label, Fuse 1.5 Amp	8502-716-001	8507-716-001	1
21	Wire Assembly, Red 7-1/2"	8220-062-059	8220-062-059	2
22	Wire Assembly, Orange 7-1/2"	8220-062-052	8220-062-052	2
*	Label, Water Level Settings	8502-775-001	8502-775-001	1
24	Wiring Harness, Power Supply	9627-923-001	9627-923-001	1

Electrical Components - Top Compartment

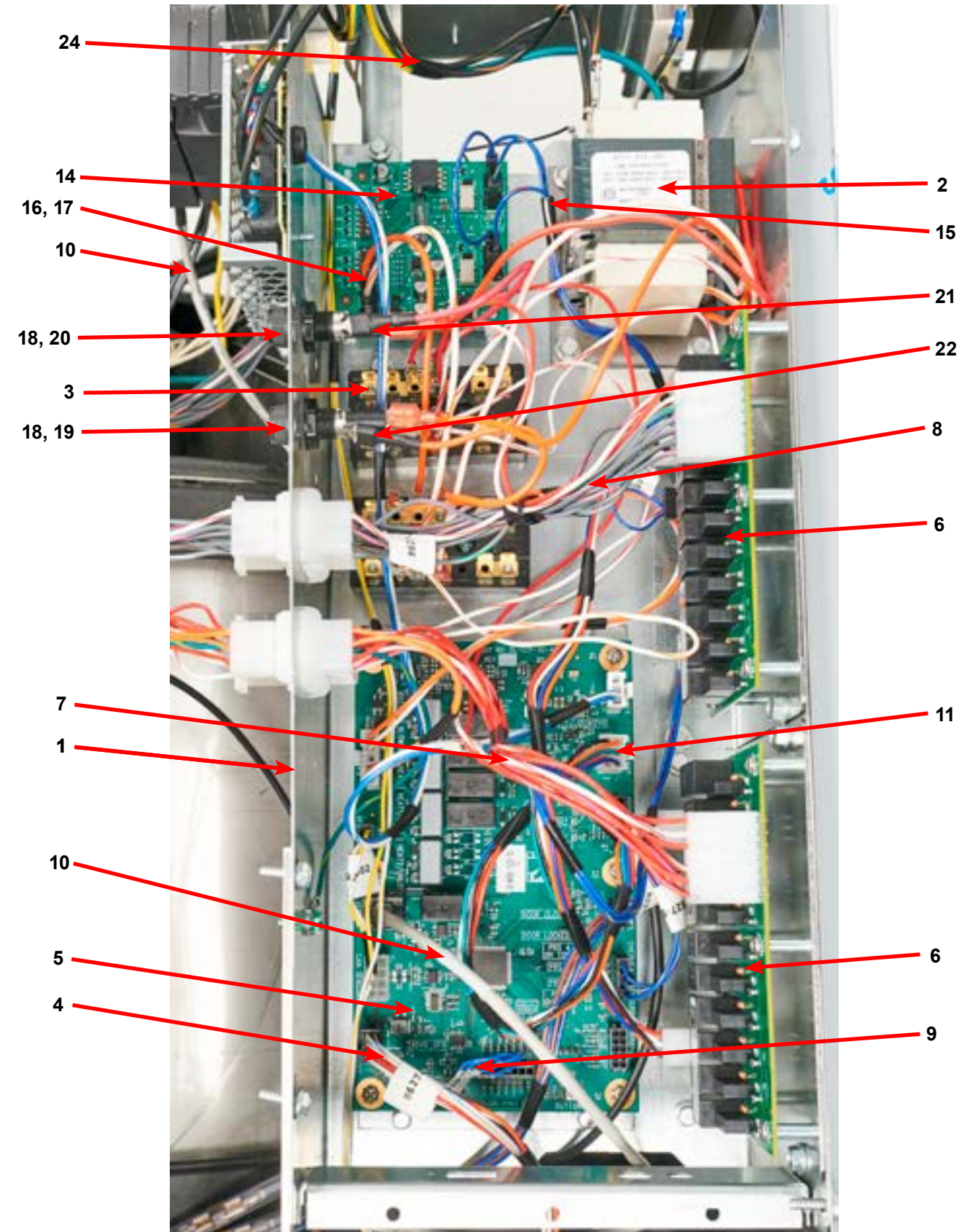

Control Panel Part # by Model

Key	Description	T-350	T-450	QTY
1	Panel Control Assembly (panel only)	9989-598-001	9989-598-001	1
*	Screw, Hxwshrhdundct #10Bx 1/2" (Control to sides)	9545-008-026	9545-008-026	4
*	Plate-Latch, Top	9452-625-001	9452-625-001	1
*	Nut, #8-32	8640-412-005	8640-412-005	2
*	Post Locator Top	9467-024-001	9467-024-001	2
*	Nut Hexkeps #6-32	8640-411-003	8640-411-003	2
*	Locator Panel	9355-001-001	9355-001-001	2
*	Screw FillHDCR 10Bx1/2" Guide	9545-008-023	9545-008-023	2
	Shield, PCB	9550-184-001	9550-184-001	1
	Nut, #8-32	8640-412-005	8640-412-005	3
2	Pushbutton Control (Black)	9035-063-001	9035-063-001	1
3	Window-Display LCD w/Gasket	9635-021-002	9635-021-002	1
4	PCB assembly Display	9857-230-003	9857-230-003	1
5	Nut Elasticstop #6-32	8640-411-003	8640-411-003	4
6	Cable Assy. USB	9806-024-001	9806-024-001	1
*	Harness Doorlock, Switches	9627-936-002	9627-936-002	1
*	Harness, P5/Pressure Switch	9627-926-002	9627-926-002	1
*	Kit-Emergency Stop, O-Series (includes #X, #Y)	9732-223-004	9732-223-004	1
7	Button- Emergency Stop, w/Latch	9035-061-002	9035-061-002	1
8	Spacer Plastic #8x1/8	8640-412-005	8640-412-005	2
9	Plate-Mounting E-Stop Button	9452-725-001	9452-725-001	1
10	Nut Hexepts #8-32	8640-412-005	8640-412-005	2
11	Switch-Contact Block, DPST, NC	9539-499-001	9539-499-001	1
*	Nameplate,Control Panel (Black)	9412-241-001	9412-242-001	1
12	Motor Ass'y, Door Locking (see Door Lock Group for parts breakdown)	9892-015-003	9892-015-003	1
13	Thermoactuator - 24VAC	9586-001-003	9586-001-003	2
14	Hex Nuts (mounting Door Lockassy. to control panel)	8640-412-005	8640-412-005	4
15	Nut-Spring	8640-399-008	8640-399-008	2
16	Screw, #10B x 1/2	9545-008-026	9545-008-026	2

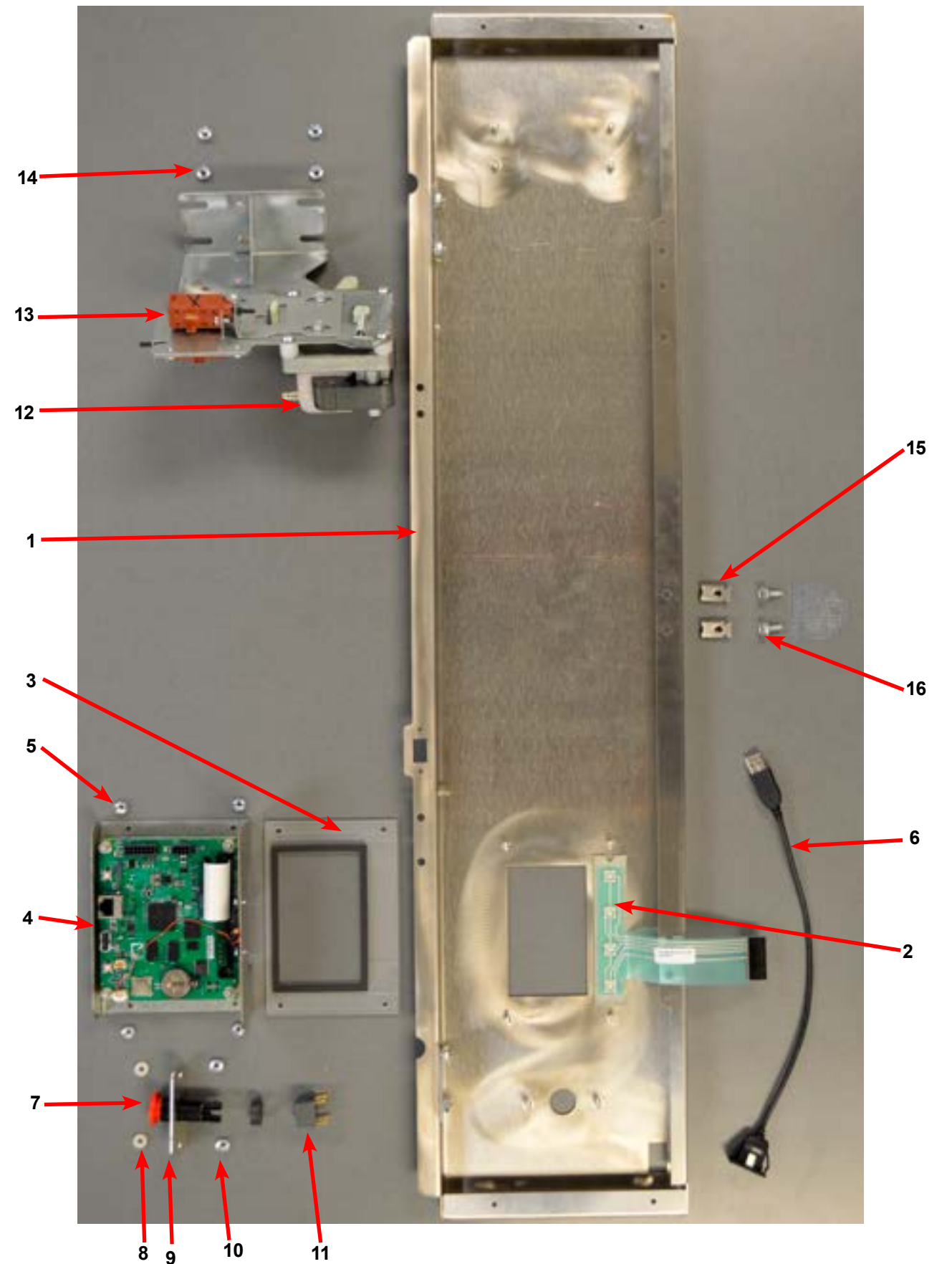

T-350 Express 208-240 Wiring Informitive

WIRING DIAGRAM

208 - 240V, 1/3PH, 60HZ

P/N 9507-015-001PR
30 LB DPL EXPRESS, VF DRIVE
WINDSOR_12.0.X

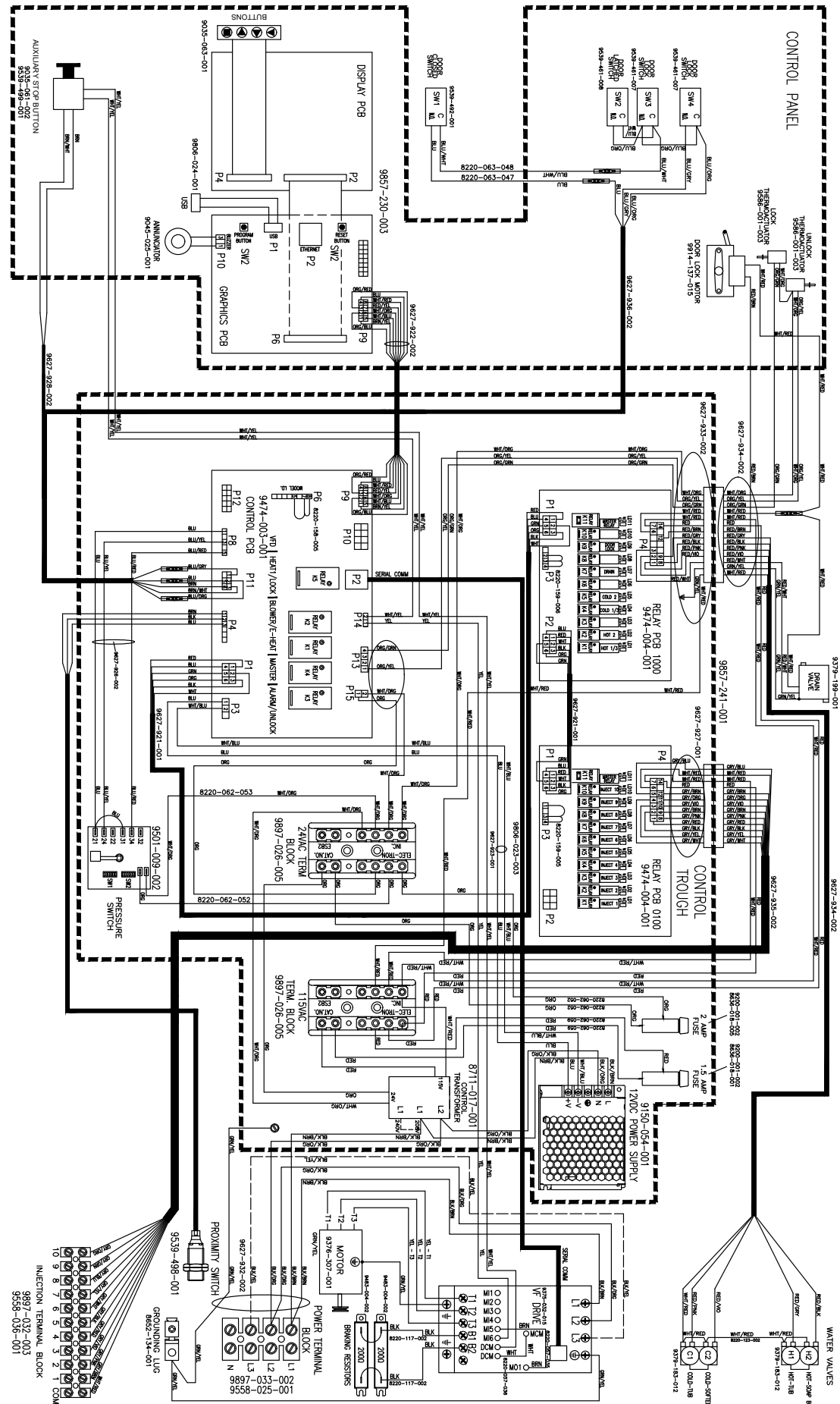

T-450 Express 208-240 Wiring Informitive

P/N 9507-016-001PR
30 LB DPL EXPRESS, VF DRIVE
WINDSOR_12.0.X

WIRING DIAGRAM 208 - 240V, 1/3PH, 60HZ

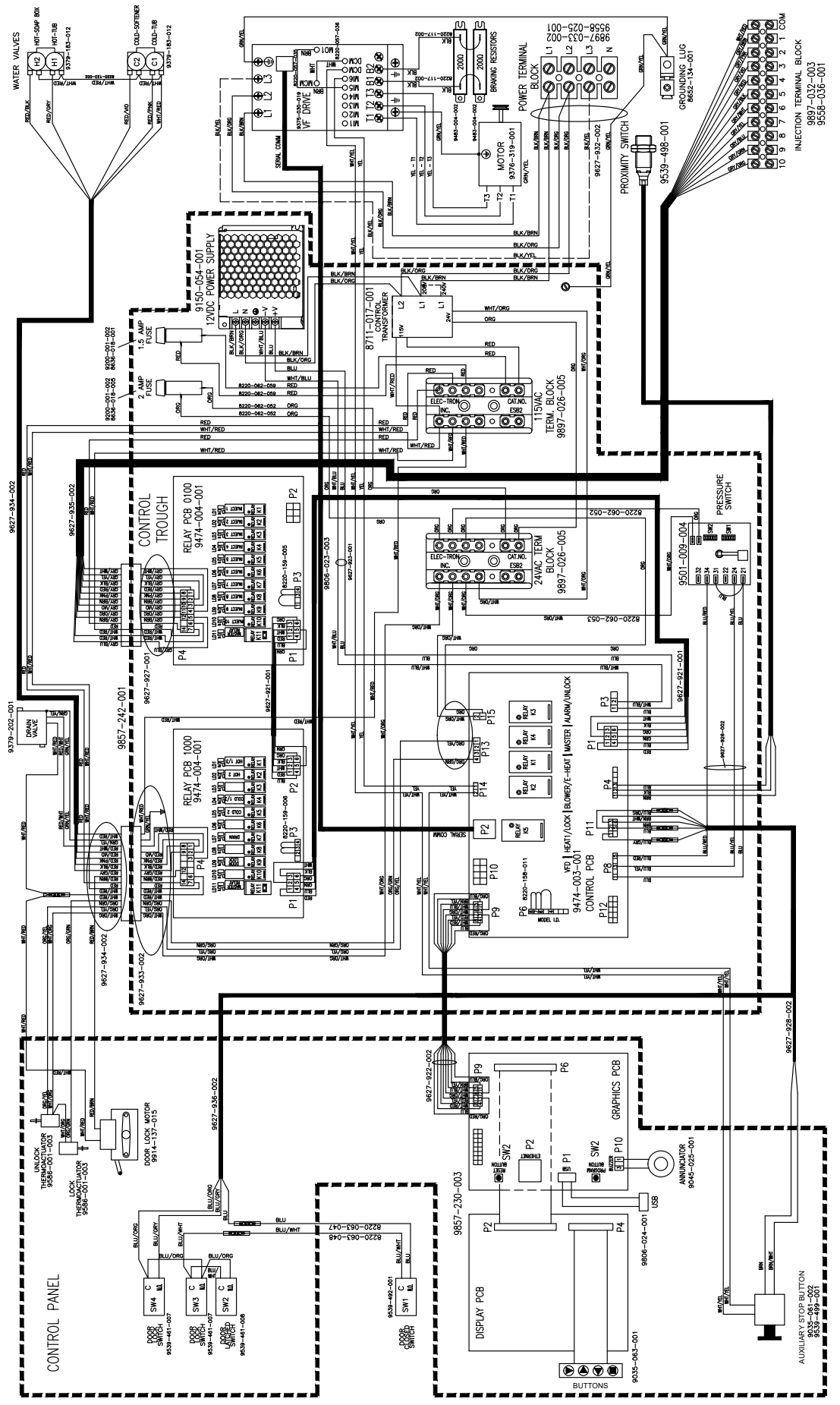

Transformer, Electrical -39 models

Key	Component	T-350	T-450	QTY
*	Operators Manual	8514-237-002	8514-239-002	
*	Wiring Schematic & Diagram	9506-553-001	9506-553-001	1
*	Controls Assembly - Trough,	9857-211-002	9857-213-002	1
*	Wiring Harness, Power Terminal Block	9627-747-006	9627-747-006	1
1	Circuit Breaker	5198-211-002	5198-211-002	1
*	Instructions, Transformer Connect	8507-230-003	8507-230-003	1
2	Controls Transformer	8711-004-003	8711-004-003	1
3	Transformer	8711-009-003	8711-009-003	1
*	Terminal Strip Marker	9558-028-002	9558-028-002	1

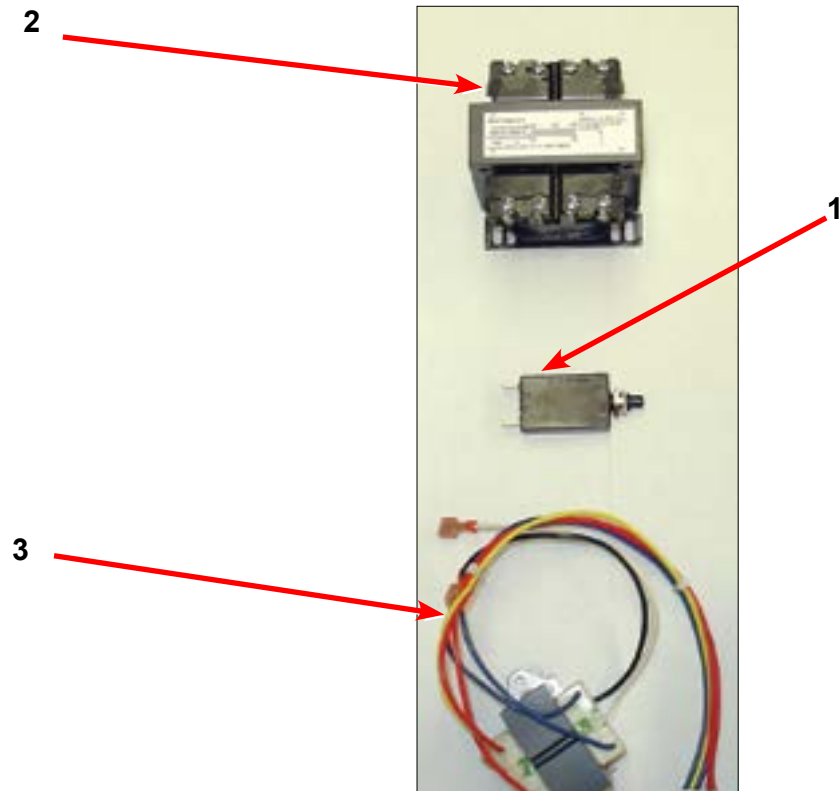

Water Valve, Drain Valve -39 models

Key	Component	T-350	T-450	QTY
1	Water Valve	9379-183-013	9379-183-013	2
2	Drain Valve 2" inch	9379-199-002		1
3	Drain Valve 3" inch		9379-202-002	1

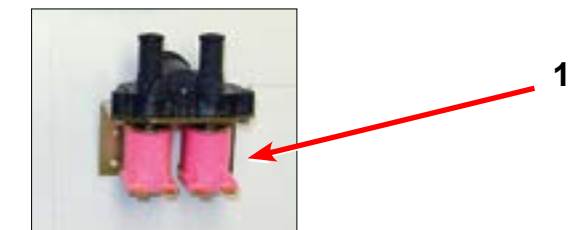
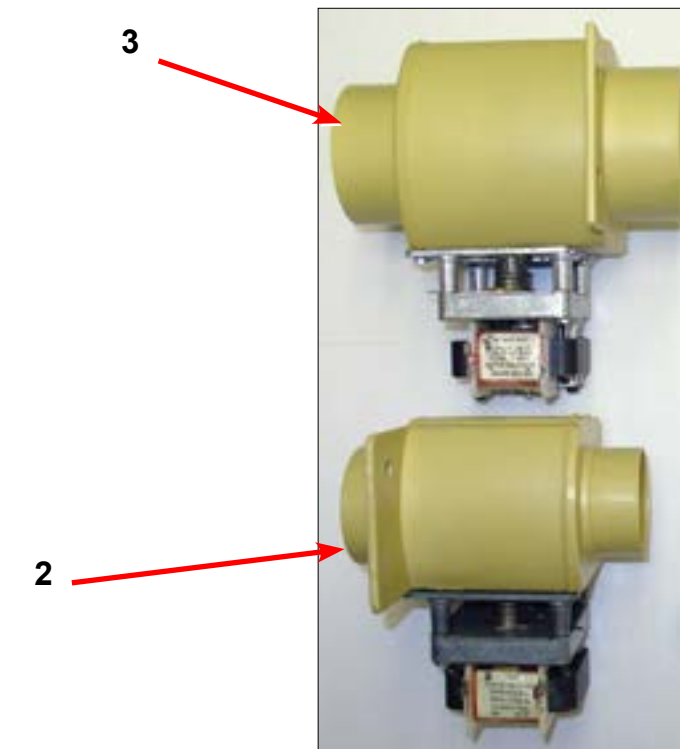

T-350 -39 O1 Diagram

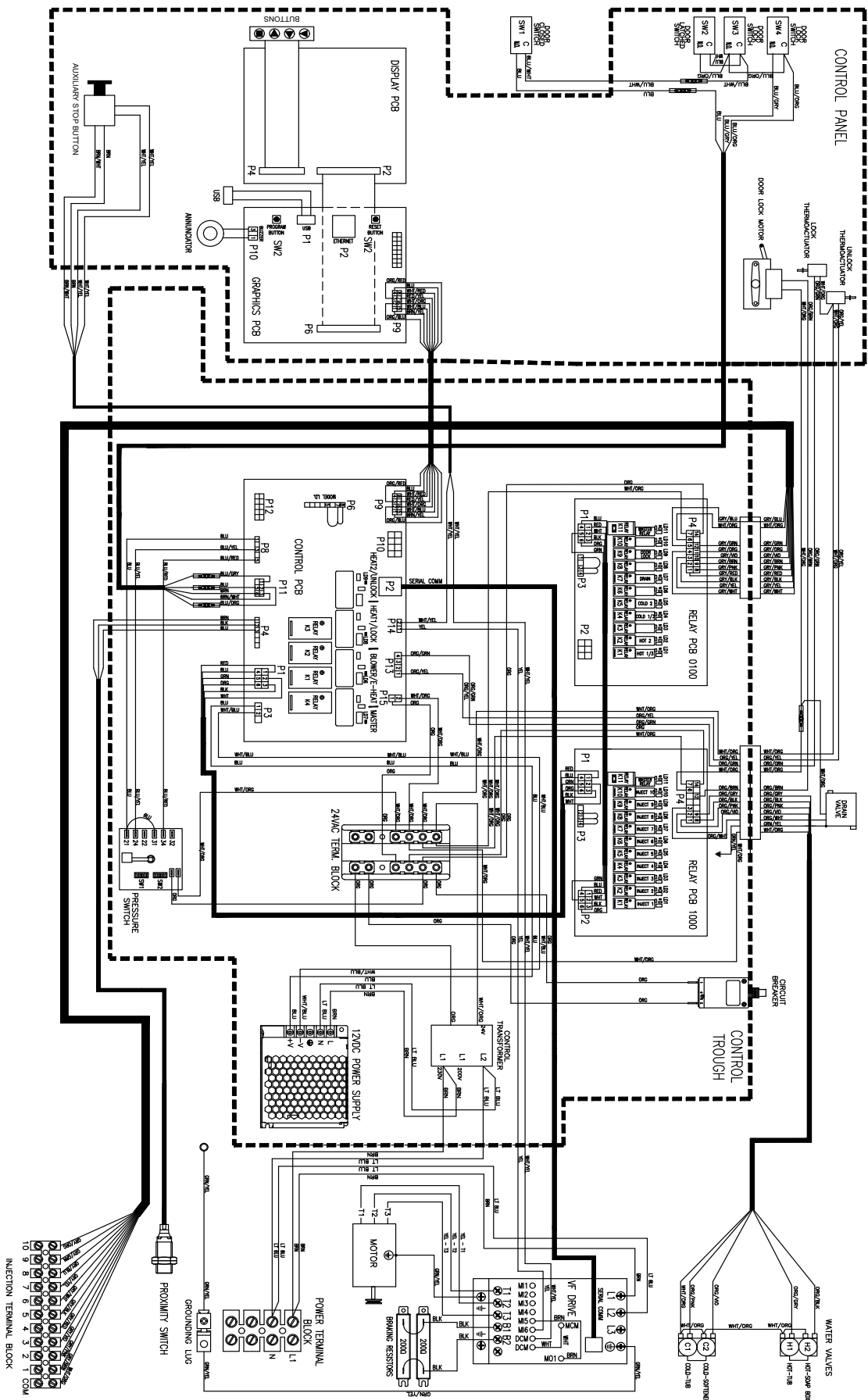

WIRING DIAGRAM 230 - 240V, 1PH, 50HZ

P/N 9507-025-001PR
20 LB OPL EXPRESS, VF DRIVE
WHD350X-38.0.X-1-X

T-350 -39 O1 Schematic

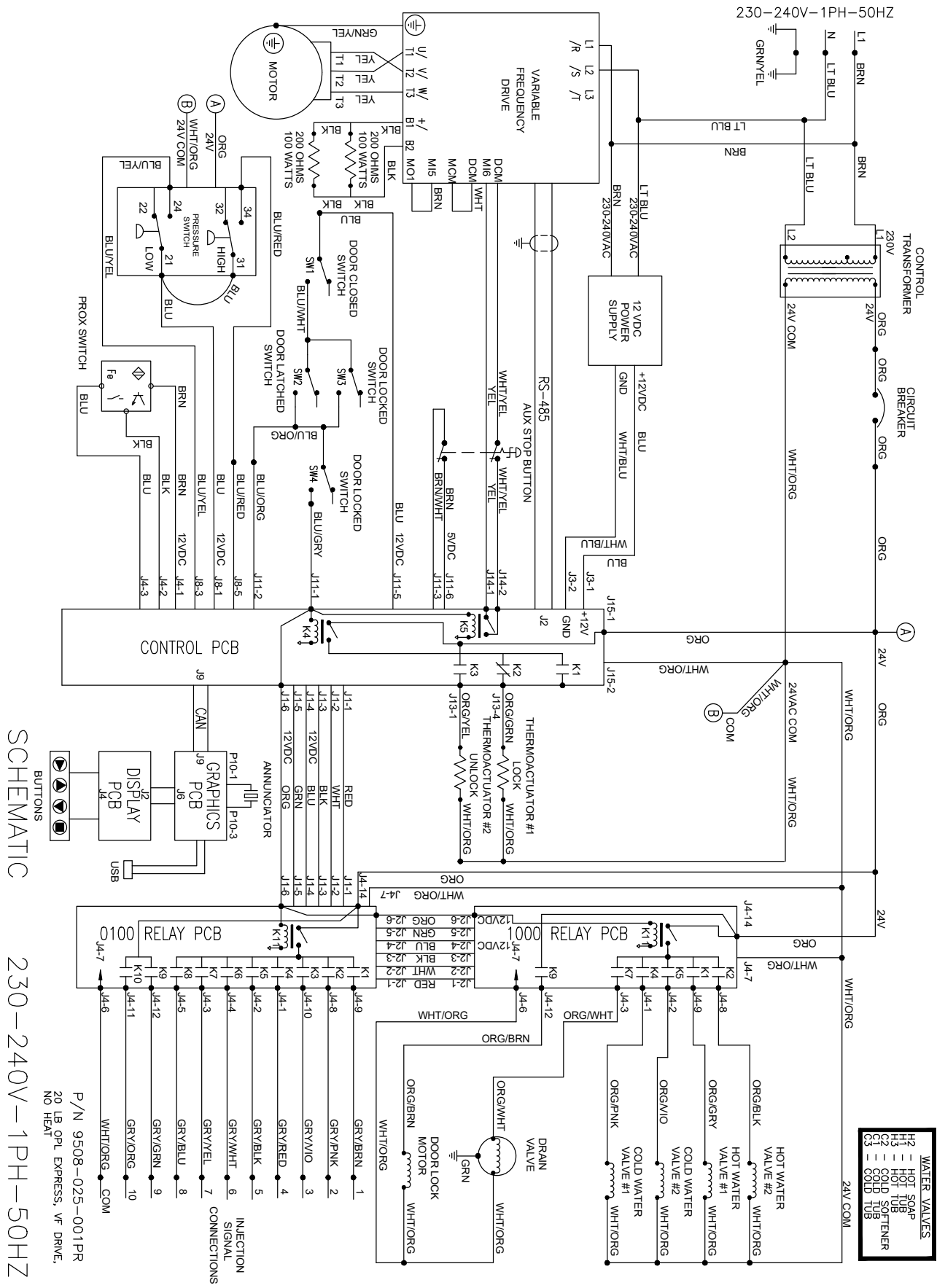

WATER VALVES
 H1 - HOT WATER VALVE #1
 H2 - HOT WATER VALVE #2
 C1 - COLD WATER VALVE #1
 C2 - COLD WATER VALVE #2
 D - DRAIN VALVE

SCHEMATIC

P/N 9508-025-001PR
20 LB OPL EXPRESS, VF DRIVE,
NO HEAT
WHT/ORNG COM

T-350 -39 O2 Diagram

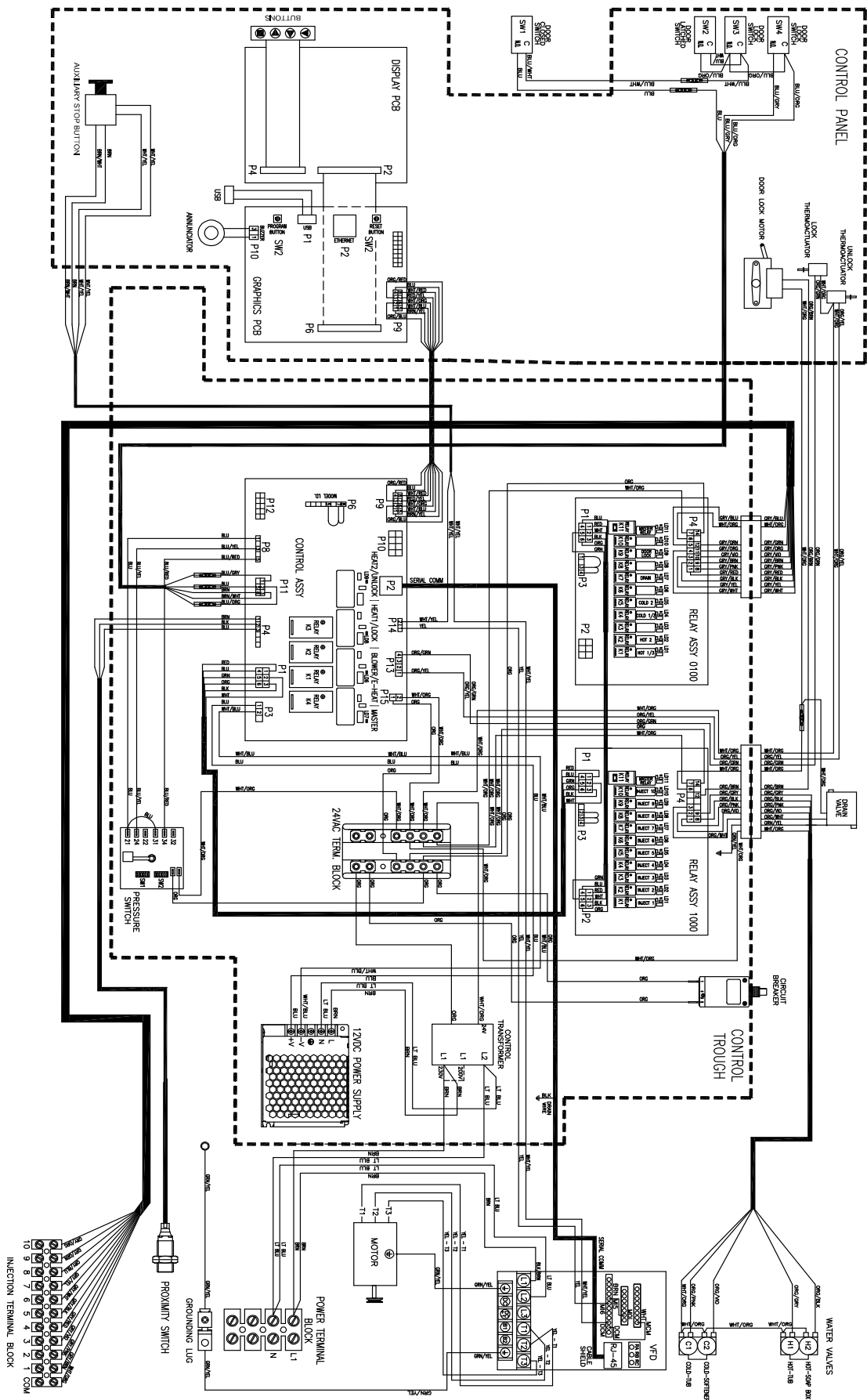

WIRING DIAGRAM 230 - 240V, 1PH, 50HZ

P/N 9507-064-001PR
20 LB OPL EXPRESS, VF DRIVE
NO HEAT
WMS030X-39_03X-1-X

T-350 -39 O2 Schematic

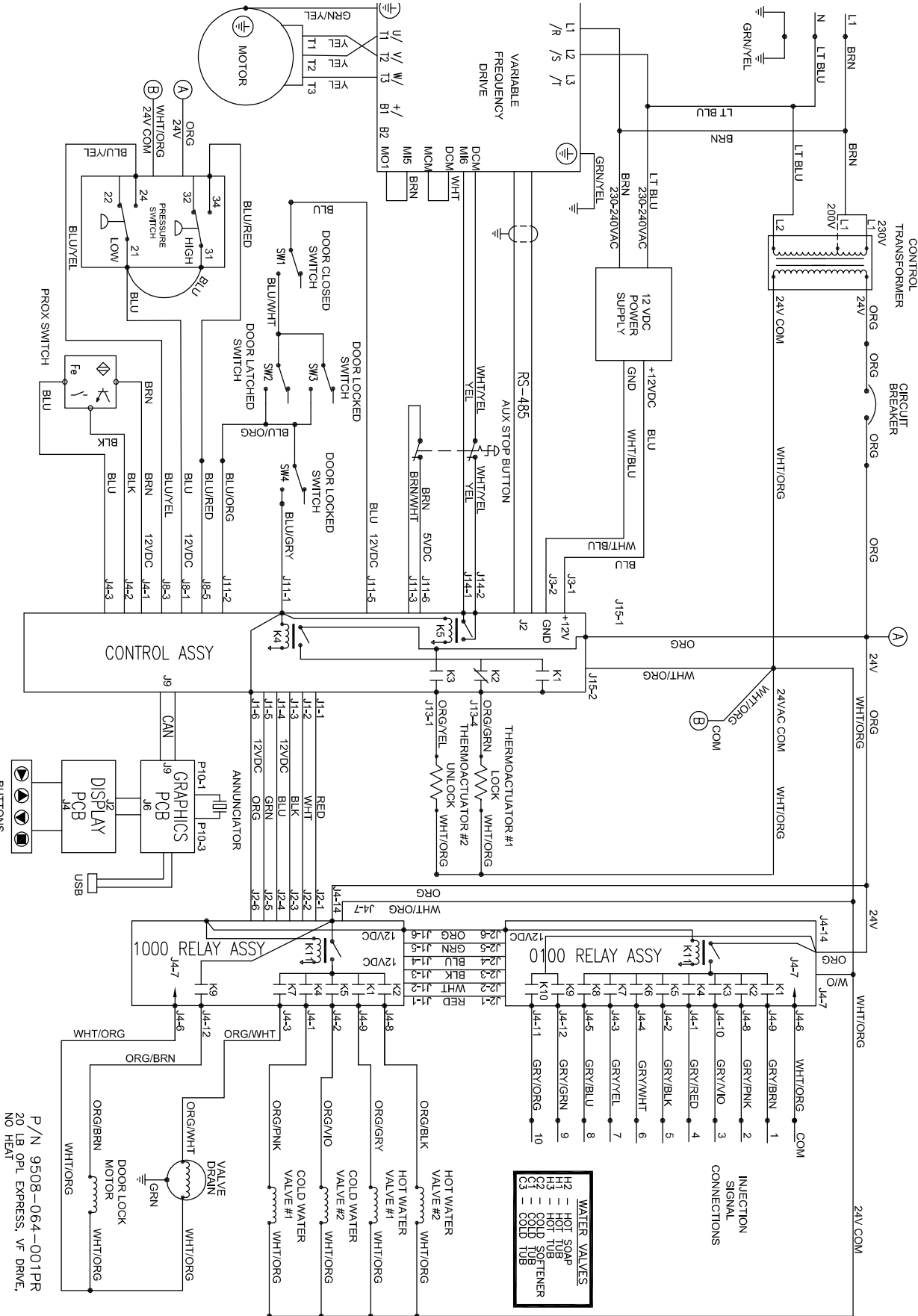

SCHEMATIC

230-240V-1PH-50HZ

P/N 9508-064-001PR
20 LB OPL EXPRESS, VF DRIVE,
NO HEAT

T-450 -39 O1 Diagram

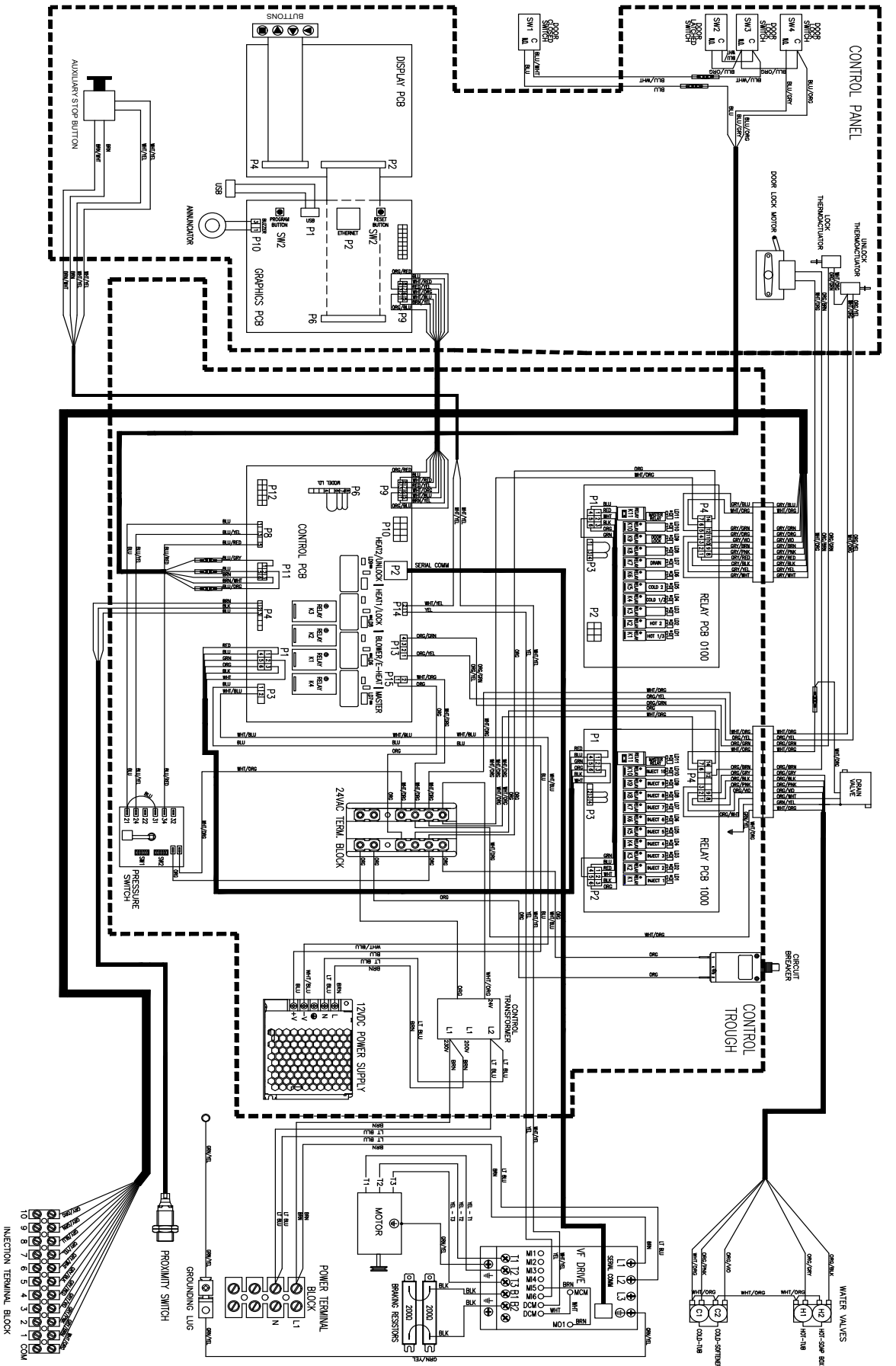

WIRING DIAGRAM 230 - 240V, 1PH, 50HZ

P/N 9507-026-001PR
 30 LB OPL EXPRESS, VF DRIVE
 NO HEAT
 W4040X-39_0_X-_-_-X

T-450 -39 O1 Schematic

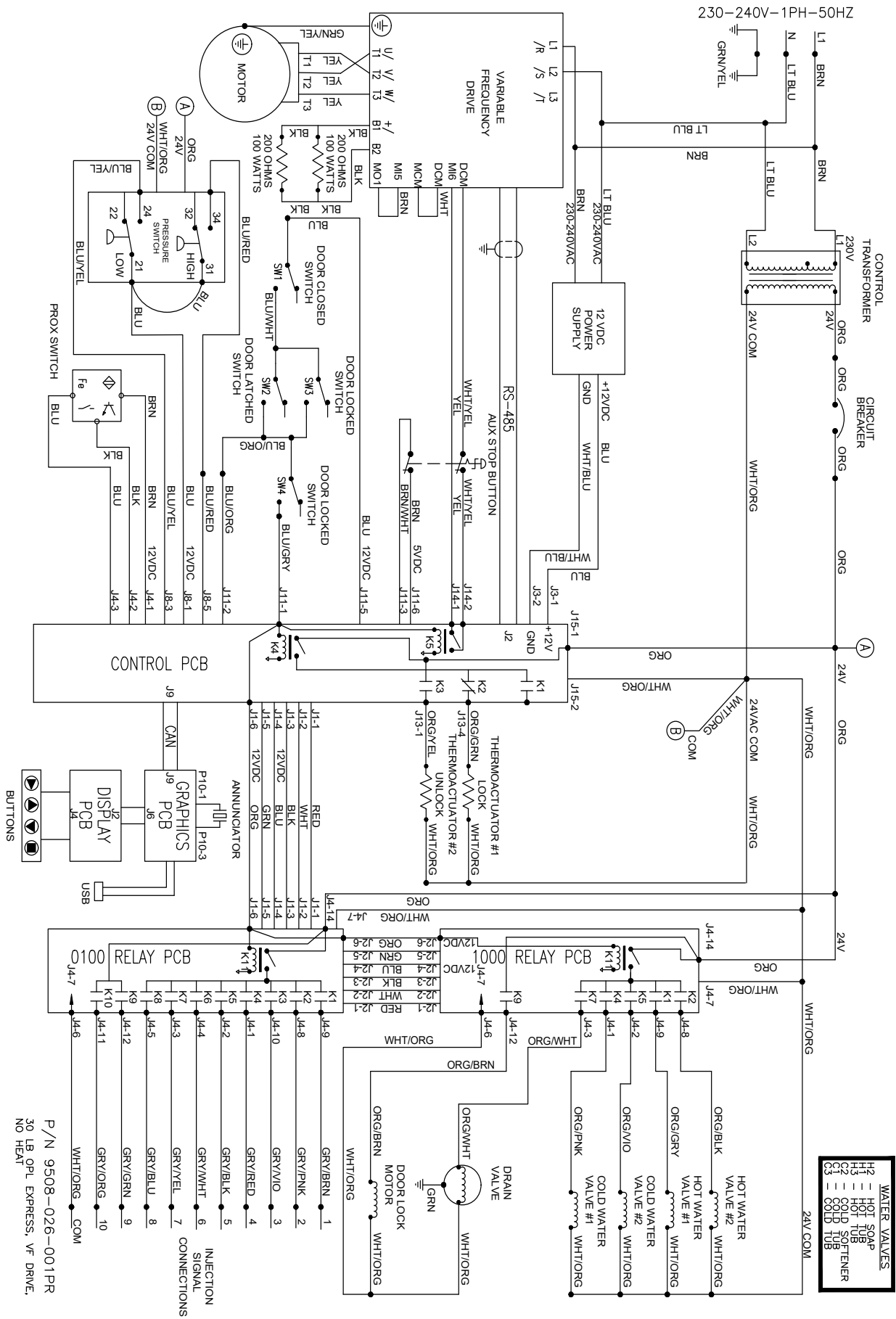

WATER VALVES	
H1	HOT SOLENOID
H2	HOT TUB SOLENOID
H3	HOT TUB SOLENOID
C1	COLD SOLENOID
C2	COLD SOLENOID
C3	COLD SOLENOID

SCHEMATIC

230-240V-1PH-50HZ

P/N 9508-026-001PR
 30 LB OPL EXPRESS, VF DRIVE,
 NO HEAT

T-450 -39 O2 Diagram

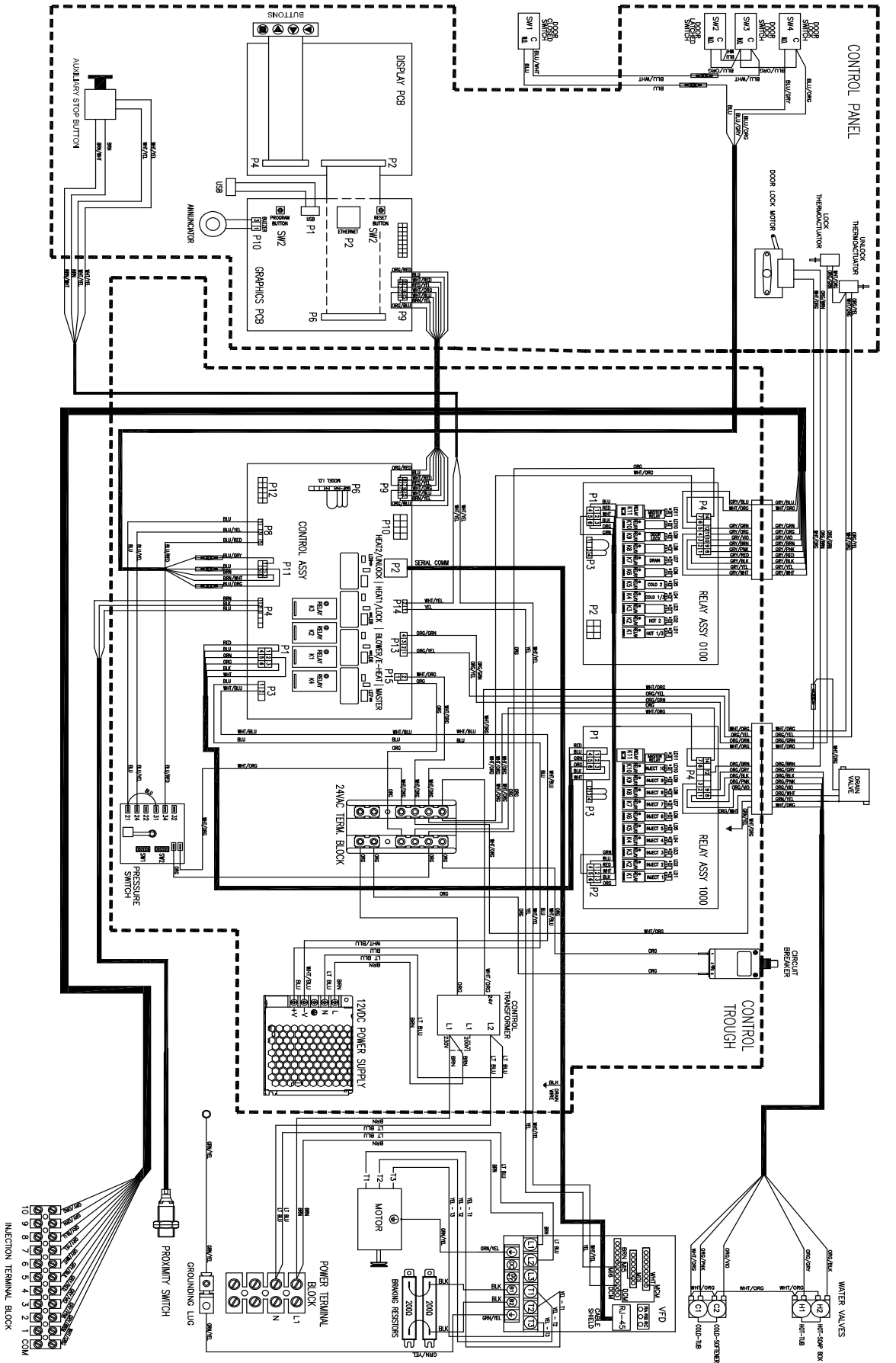

WIRING DIAGRAM 230 - 240V, 1PH, 50HZ

P/N 9507-065-001PR
30 LB OPL EXPRESS, VF DRIVE
NO HEAT
WINDBOX -39, 02V- X

T-450 -39 O2 Schematic

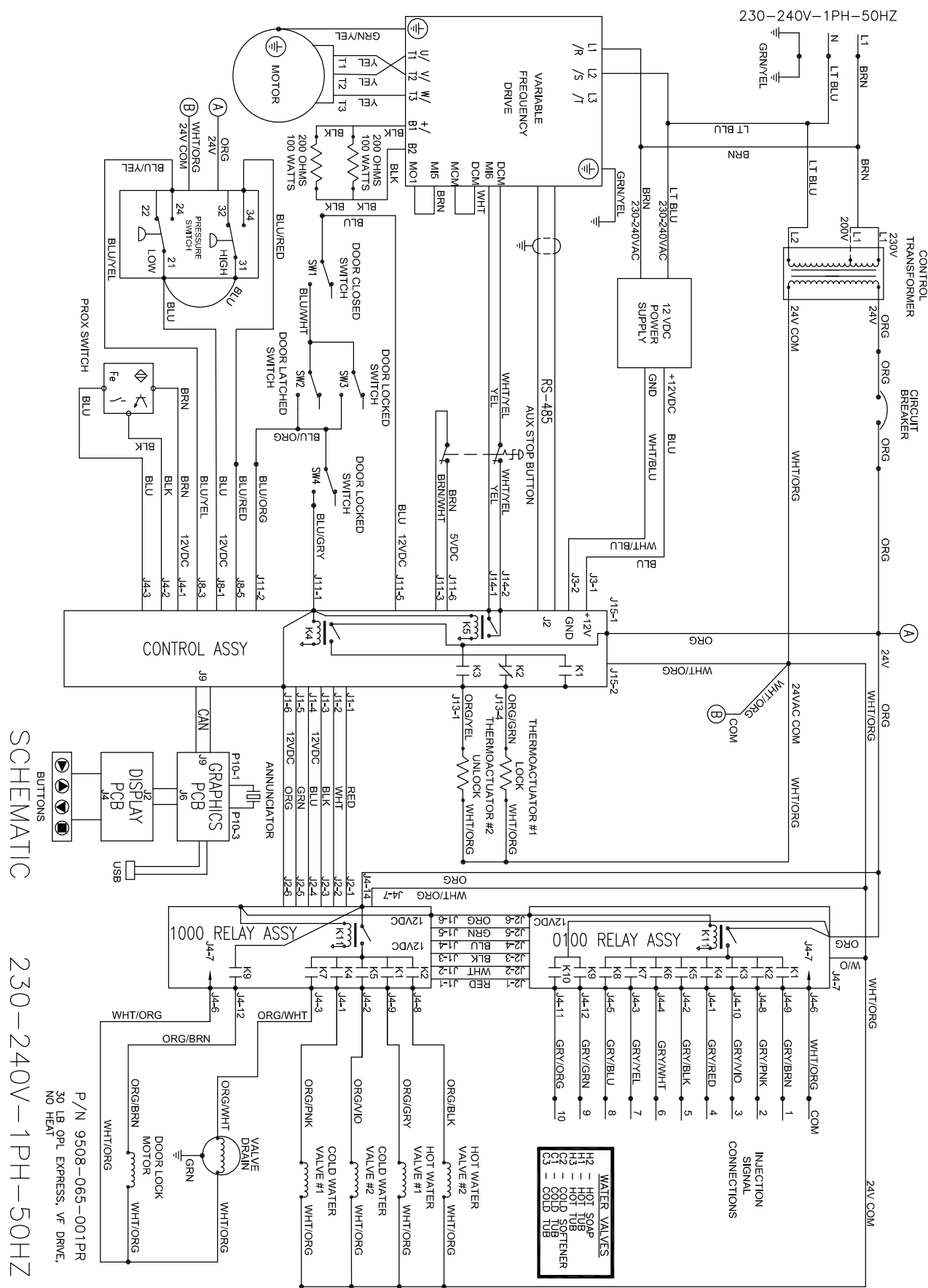

SCHEMATIC

230-240V-1PH-50HZ

P/N 9508-065-001PR
30 LB OPL EXPRESS, VF DRIVE,
NO HEAT