



DEXTER[®]
LAUNDRY

**USE THE BLUE TABS LOCATED ON THE
RIGHT AND LEFT SIDES OF THE FOLLOWING
DOCUMENT TO ADVANCE TO EACH SECTION.**











DEXTER
LAUNDRY



6-Cycle On-Premise Washers
WN1800XA-12EV4X
Non-Express (100G)

Equipment Safety Warnings Symbols and Terminology Used in this Equipment

 DANGER	Indicates an imminently hazardous situation, which if not avoided, will result in death or serious injury.
 WARNING	Indicates a potentially hazardous situation, which if not avoided could result in death or serious injury.
 CAUTION	Indicates a potentially hazardous situation which, if not avoided, may result in minor or moderate injury. It may also be used to alert against unsafe practices. Minor burns, pinch points that result in bruises and minor chemical irritation.
NOTICE	Indicates information or a company policy that relates directly or indirectly to the safety of personnel or protection of property.
	This is the user caution symbol. It indicates a condition where damage to the equipment resulting in injury to the operator could occur if operational procedures are not followed. TO REDUCE THE RISK OF DAMAGE OR INJURY, refer to accompanying documents; follow all steps or procedures as instructed.
	This is the electrical hazard symbol. It indicates that there are DANGEROUS HIGH VOLTAGES PRESENT inside the enclosure of this product. TO REDUCE THE RISK OF FIRE OR ELECTRIC SHOCK, do not attempt to open the enclosure or gain access to areas where you are not instructed to do so. REFER SERVICING TO QUALIFIED SERVICE PERSONEL ONLY
	Caution! There are sharp edges on various sheet metal parts internal to the enclosure. Use safety consciousness when placing or moving your hands while working in the interior of this equipment.
	Caution! To reduce the risk of damage to the Water Inlet Valve, do not supply inlet water with a temperature that exceeds 70° C.
	Caution! To reduce the risk of fire or explosion, do not operate this equipment in any hazardous classified (ATEX) environment.

Equipment Safety Warnings Symbols and Terminology Used in this Equipment



Warning! Do not operate equipment if door glass is damaged in any way.



Warning! Keep clear of rotating parts.



Prohibited! Do not enter this equipment or space.



Prohibited! Do not step or stand on this equipment.



Prohibited! Do not operate without all guards and covers in place.





Prohibited! Do not operate without all guards and covers in place.



Prohibited! Do not wash clothing impregnated with flammable liquids (petrochemical).



Prohibited! Do not allow children to play in or around equipment.

⚠ DANGER	Indicates an imminently hazardous situation, which if not avoided, <u>will result</u> in death or serious injury.
⚠ WARNING	Indicates a potentially hazardous situation, which if not avoided <u>could result</u> in death or serious injury.
⚠ CAUTION	Indicates a potentially hazardous situation which, if not avoided, <u>may result</u> in minor or moderate injury. It may also be used to alert against unsafe practices. Minor burns, pinch points that result in bruises and minor chemical irritation.
NOTICE	Indicates information or a company policy that relates directly or indirectly to the safety of personnel or protection of property.
	This is the user caution symbol. It indicates a condition where damage to the equipment resulting in injury to the operator could occur if operational procedures are not followed. TO REDUCE THE RISK OF DAMAGE OR INJURY, refer to accompanying documents; follow all steps or procedures as instructed.
	This is the electrical hazard symbol. It indicates that there are DANGEROUS HIGH VOLTAGES PRESENT inside the enclosure of this product. TO REDUCE THE RISK OF FIRE OR ELECTRIC SHOCK, do not attempt to open the enclosure or gain access to areas where you are not instructed to do so. REFER SERVICING TO QUALIFIED SERVICE PERSONEL ONLY.
	Caution! To reduce the risk of fire or explosion, do not operate this equipment in any hazardous classified (ATEX) environment.



WARNING

	<ul style="list-style-type: none"> • All washers must be installed in accordance to all applicable electrical, plumbing and all other local codes. • These installation and operation instructions are for use by qualified personnel only. To avoid injury and electrical shock, do not perform any servicing other than that contained in the installation and operation instructions, unless qualified.
	Do not install washers in an explosive atmosphere.
	<ul style="list-style-type: none"> • Care must be stressed with all foundation work to ensure a stable unit installation, eliminating possibilities of excessive vibration. • Foundation must be level within 13 mm to ensure proper washer operation.
	Do not operate washer if door glass is damaged in any way.
	Do not wash clothing impregnated with flammable liquids (petrochemical).



WARNING







	Children should be supervised to ensure they do not operate or play in or around equipment.
	Keep all panels in place to protect against electrical shock and injury and add rigidity to washer.

This appliance is not intended for use by persons (including children) with reduced physical, sensory or mental capabilities, or lack of experience and knowledge, unless they have been given supervision or instruction concerning use of the appliance by a person responsible for their safety.

A washer should not be allowed to operate if any of the following occur:

- Excessive high water level.
- Machine is not connected to a properly earthed circuit.
- Door does not remain securely locked during the entire cycle.
- Vibration or shaking from an inadequate mounting or foundation.

	Warning! Do not operate equipment if door glass is damaged in any way.
	Warning! Keep clear of rotating parts.
	Prohibited! Do not enter this equipment or space.
	Prohibited! Do not step or stand on this equipment.
	Prohibited! Do not operate without all guards and covers in place.
	Prohibited! Do not operate without all guards and covers in place.
	Prohibited! Do not wash clothing impregnated with flammable liquids (petrochemical).
	Prohibited! Do not allow children to play in or around equipment.

	Prohibited! Do not attempt to open, touch, or proceed before referring to the manual or unless qualified.
	Mandatory! Read all supporting documentation before operating or maintaining equipment.
	Mandatory! Disconnect power before servicing equipment.
	Mandatory! Lock out and tag out before servicing this equipment.
	Mandatory! Disconnect water supply before servicing equipment.
	Mandatory! Children should be supervised to ensure they do not operate equipment.

Adjustment for the Door Lock Assembly..75 & 76
Adjusting the Loading Door77
Loading Door Removal77
Loading Door Hinge Removal.....77
Loading Door Disassembly78
Loading Door Reassembly78
Control Panel Name Plate Decal78
Name Plate Removal78
Re-Installation of Name Plate.....78
Outer Cabinet Removal79
Door Locking Gear Motor80
Thermoactuators80
Lock Thermoactuator80
Unlock Thermoactuator80
Drive Belt Removal.....80
Tub Back, Bearing and Cylinder Assembly81
Basket Pulley, Bearing Housing, Water Seals & Tub Back82-83
T-750, T-900, T-950, T-1200 & T-1450 Bolt Torque Chart84

Section 6:

Control Mounting Trough.....88
Main Data Communication Cable.....88
Circuit Breaker/Fuse88
Main Control Printed Circuit Board.....88
PCB Transformer Step Down.....88
Controls Transformer.....89
Main Relay Printed Circuit Board89
LED Printed Circuit Board Temperature & Start/ Display Push Button.....89
Power Connection Terminal Block89
Emergency Stop Button & Switch Assembly.....89
Pressure Switch90-91
Delta Variable Frequency Drive92
Delta VFD Motor Leads.....92
Delta VFD Dynamic Braking Resistors.....92
Delta VFD Cooling Fan92

Section 7:

Machine Electrical & Wiring Schematics Start Circuit96

Fill Circuit96-97
Wash Circuit97
Drain, Rinse 1 & 2 & Final Rinse Circuit97
Extract Circuit.....97
Thermoactuator and Shake Out Circuit.....98
End of Cycle Circuit98
Diagrams & Schematics.....100-103

Section 8:

Parts Data

C-Series Accessories.....104
Wiring Harness Part # by Model.....104
Cabinet and Front Panel Group Part # by Model107-108
Soap Dish.....109-110
Rear View Access Part # by Model.....111-112
Cylinder, Seals & Bearings Part # by Model113-114
Door Lock Part # by Model115-116
Loading Door Part # by Model117-118
Water Inlet Part # by Model.....119-120
Water Hose Routing.....121-122
Water Inlet Valve Breakdown I.....123-124
Drain Valve Group Part # by Model.....125
Chassis and Drain Part # by Model127-128
Electrical Components - Top Compartment129-130
Control Panel Part # by Model.....131-132
Labels and Diagrams All C-Series Models.....133

Section 9:

Coin Handling

Optical Switch.....135
Imonex136
Munzpurfer Electronic + Troubleshooting...137-144

**Section 10:
50 Hz Models**

-39 Parts.....145-146
50HZ Diagrams & Schematics.....

**Section 11:
Maintenance**

Preventative Maintenance147

Specifications for below models
are outlined in this book:

WN1800-XA12EVX 208-240 volts 60hz Single Phase or Three Phase

T-1800 Machine Dimensions

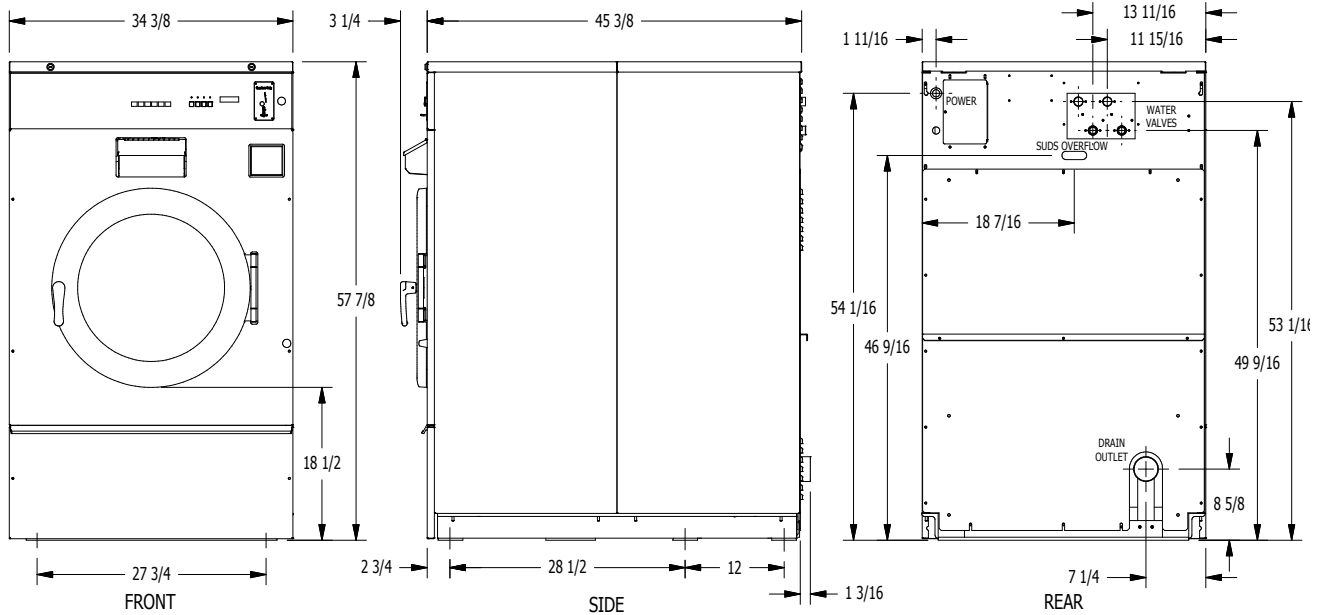

Section 1:

Machine
Mounting

Section 2:

Machine Installation & Operating Instructions

Installation & Operation

All washers must be installed in accordance with all local, state and national building, electrical, and plumbing codes in effect in the area.

Foundation Requirements

The washer must be securely bolted to a substantial concrete floor, or mounted upon a suitable base which is in turn securely bolted to a substantial concrete floor. Care must be stressed with all foundation work to insure a stable unit, eliminating vibration. All installations must be made on sound concrete floors. See mounting dimensions for each model being installed.

Mounting

A concrete pad or steel base which elevates the machine 4 to 6 inches above the floor level. To provide easy access to the loading door, it is recommended to allow a minimum of 24" of clearance behind the rear of the machine for service as is shown. Dexter highly recommends the use of a dry expansion grout mix.

Proper Machine Grout Installation

Grout should be installed between base (if used) and concrete floor on all side rails and crossmembers. If using a base you should grout between base top and machine frame and all side rails and crossmembers. (Grouting between the machine base and the floor is absolutely required for all 200G Express Models)

Mounting Holes

See mounting dimensions for the machine model you are installing in previous section. They also show a typical concrete pad arrangement. It is highly recommended that you use all mounting holes supplied with each model. Note: Mounting bolts should be checked frequently to insure that they remain tight. The machine should be checked with a spinning load to be sure there is no unusual vibration or movement between the machine and the base or floor. Please note: Machine grouting is highly recommended as grouting insures stability and longevity.

Plumbing

Water supply hoses are furnished with each machine. The threaded connections on the hoses are standard garden hose type thread. Separate hot and cold water lines with shut off valves or faucets for inlet hose connections must be provided, maintaining 30 to 120 p.s.i. water flow pressure. Maximum water temperature is 180 degrees.

Drain

The drain outlet tube at the rear of the machine is 3" in outside diameter on models T-1800. All drains are gravity drain. Adequate fall must be maintained for proper drainage.

Protective Film

The machine may have protective adhesive film on the front escutcheon area and the front and side stainless steel panels. The film may be peeled off before putting the machine into service.

Electrical

Dexter single/three-phase 208-240VAC 60 Hz washing machines are intended to be permanently installed appliances. No power cord is provided. The machine should be connected to an individual branch circuit not shared by lighting or other equipment. The connection should be sheathed in liquid tight flexible conduit, or equivalent, with conductors of the proper size and insulation. A qualified technician should make such connections in accordance with the wiring diagram.

A U.L. approved receptacle, which has been properly grounded in accordance with local electrical codes must be used with the machine. Each unit should be connected to an individual branch circuit not shared by lighting or other equipment. Conductors of the proper size and insulation (suggested size below) should be used.

To Make Electrical Connections

Disconnect all power to the washer. Remove screw and lift out the cover located in the upper left corner

of the machine (as viewed from the back).

- If power is 208-240-3PH-60Hz, connect L1, L2, L3 and ground. If there is a high leg it must be connected to L3. It is highly recommended to use a TVSS.
- If power is 208-240-1PH-60Hz, connect L1, L2 and ground. If power is 120-1PH-60Hz, use a UL approved receptacle with proper external ground.

NOTE: It is important that the grounding screw next to the power terminal block TB-1 be connected to a good external ground.

Controls Transformer

The controls transformer is located inside the control trough and steps a range of 208 to 240 volts down to 115 volts. There are two terminals on the controls transformer for the primary (incoming) power. Use the terminal marked "208V" for power supplies between 208 and 219 volts. Use the terminal marked "230V" for power supplies between 220 and 240 volts.

NOTE: transformer must be set at proper tap for proper operation.

Electrical Connections

Electrical power connections are made to the small terminal block located in the rear of the control trough. The terminal block is accessed by opening the top panel of the machine.

- 1 Phase or 3 Phase connections
- 208-240 volts, 60 Hz.
- 3 wire plus ground
- Suggested Minimum Wire Size -- #10 Ga.

Fusing Requirements:

Dual element time delay fuse or equivalent breaker of amperage specified below.

- 1 Phase or 3 Phase 30 amp
- WC1800



Rotation in extract as viewed through glass door at front of washer models WC1800 will be counter-clockwise.



WARNING

Always disconnect electrical power to the machine before performing any adjustments or service.

Liquid Chemical Connection

In the left rear corner of the washer is the chemical injection assembly. This is where all chemical hose connections are made. The chemical hoses should be inserted into the round pvc pipe a minimum of 14" and a maximum of 18" to eliminate chemical buildup in the pipe and/or restrict water flow to the tub.



Injection Source Details

The washer control may be programmed to send output signals for a chemical injection system. There is a separate terminal block for connection of the external injection signals. For the injection sources, program codes 0 through 6 are as shown in the table below. Injection signal will trigger a 120 volt reading at rear terminal block for approximately 5-10 seconds and will start to trigger at about 10-15 seconds after start of fill bath. (Chemical Injection Signals are shown in the programming section.)

**208/240 VAC
Power Connections**

**Ground
Connection**

**120VAC Injector
Supply Connections
Power Connections**



**L1
L2
L3
N (not needed)**

**A
B
C
D
Common**

**Dexter Recommended
Connections**

**Controller Programmed
Signals**

**Injection Terminal
Block Connection**

Detergent
Bleach
Starch
Sour/Softener

1
2
3
4
5
6
0

A
B
C
D
A and B
C and D
None

Note : The Wash Cycle programming mode will automatically exit and return to the Idle mode if no buttons are pushed for one minute.

Emergency Stop / Safety Door Lock

This machine is equipped with a Safety Door Lock that locks the door closed from when the cycle is started until the cycle is complete. The door lock prevents opening the door for up to 3 minutes if the power is interrupted during the cycle.

The Emergency Stop button pauses the washer and allows the door to be opened during the cycle after the Safety Door Lock releases. When the Emergency Stop button is pressed an alarm will sound and the display will begin counting down from "3". If the button is released before 3 seconds elapse, the alarm will stop and the cycle will continue normally. If the Emergency Stop is held down for 3 seconds, the display will count down to "0" and the washer will begin stopping movement and water flow and begin draining water from inside the washer. Though the machine may stop wash movement quickly, it may take up to 3 minutes for the door to unlock. During that time the alarm will continue to sound. When the alarm stops, the door may be opened. The washer may be restarted by closing and latching the door, and pressing the Start button. If the washer was stopped during final extract, the cycle will be ended. If the washer is stopped for more than 1 hour, the cycle will be terminated. If the emergency stop is triggered a second time during the cycle, the cycle will be terminated.



Operating Instructions

Microprocessor

Prior to operation, the micro computer should be set to display the amount of vend price being offered and the cycle to be given to the user. NOTE: Should a power loss occur during cycle and when power returns, P U S H will be displayed in window and customer must push the START button to continue the cycle.

Starting the Washer

- A. Load the clothes loosely in the cylinder and latch the door securely. Be sure clothing does not get caught between the door gasket and tub front when closing the door.
- B. Pour low-sudsing powdered detergent in the amount shown below into the detergent dispenser on top of the machine. Rinse conditioners may also be added to the dispenser. The correct location is shown on the dispenser lid.

NOTE: To close the door the handle, must be in the horizontal position and then moved to the vertical position. After moving the door to the closed position, the handle must be turned down to the vertical position to latch the door for machine operation.

- C Using the TEMPERATURE SELECT buttons on the front, select the desired temperature. If temperature pricing is being used you will display price changes as you push the desired temperature selection.
This selection must be made before inserting coins to satisfy temperature price selected. If coins or value are added after extended plus cycle vend price is met it will be lost without credit. If water temperature pricing feature is active and vend price met and machine started the customer may change temperature selections of equal to or lower priced temperature selections already inserted into machine.

- D. Insert coins, tokens or activate card reader to meet displayed vending price. The washer will start, the display will read PUSH and the green "on" led will glow. The green start pushbutton must be pushed to start cycle time countdown and machine starting to run. "Door" will display if loading door is not closed and handle locked.
- E. If utilizing ADD PLUS CYCLE \$.000 option
The front display will scroll, ADD PLUS CYCLE .25(example),amount to be added. User will have 1 minute to insert proper amount to activate this option.
- F. At the correct time in the wash bath cycle the display will scroll "ADD BLEACH" indicating the time for adding bleach if desired. The timing is 2 1/2 minutes after start of wash bath the light will come on and stay on for 2 1/2 minutes or end of wash bath.

End of Cycle

When the cycle is completed, the end of cycle buzzer will sound and the "on" light will go off. The loading door can now be opened by turning the door handle to the indicated position and pulling. Leave the clothes door open when the machine is not in use. Also, at the end of cycle the display will reset to the original amount required to start.

Detergent Measurements By Washer Model

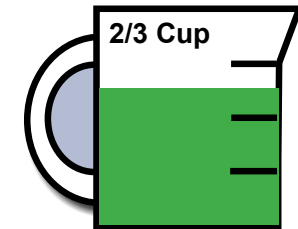

Magnum Load T-1800 Washer

TRANSIENT VOLTAGE SURGE SUPPRESSORS

Like most electrical equipment your new machine can be damaged or have its life shortened by voltage surges due to lightning strikes which are not covered by factory warranty. Local power distribution problems also can be detrimental to the life of electrical components. We recommend the installation of transient voltage surge suppressors for your new equipment. These devices may be placed at the power supply panel for the complete installation and don't require an individual device for each machine.

These surge protectors help to protect equipment from large spikes and also from small ongoing spikes in the power that occur on a day to day basis. These smaller surges can shorten overall life of electrical components of all types and cause their failure at a later date. Although they can't protect against all events, these protective devices have a good reputation for significantly lengthening the useful life of electronic components.

Electronic Components are helped to have a longer useful life when they are supplied with the clean stable electrical power they like.

We are including the following names and links to a few suppliers of these devices for those who don't currently have a source.

MANUFACTURER	LINK
MCG Surge Protection	mcgsurge.com
Eaton Corporation	eaton.com/us/en-us
Schneider Electric	se.com/us/en
Asco Power Technologies	ascopower.com/us/en
Emerson Electric Co.	emerson.com/en-us

Section 3:

Machine Programming Instructions

Bath Cycle Time "ct"

0 to 15 minutes for Prewash, Rinse1 and Rinse 3 to 15 minutes for Wash and Final Rinse. For the baths that can, if the time is set to zero, then that bath will be eliminated from the cycle.

Bath Water Temperature "t"

HH – hot, CH – warm, CC – cold, EE – no water. The owner can set the bath default. For the wash bath, the default is over ridden for that cycle by the customer when the temperature is selected.

Bath Water Level "L"

LO – low The owner can change the displayed value, but for a coinwasher only LO will be put into the cycle.

Bath Delay Fill "dF"

The selections are "d" for delay the bath time until water level is reached or "t" for decrement bath time during the fill.

Bath Spin Time "S"

0 to 10 minutes for Prewash, Wash, Rinse1 and Rinse2 1 to 10 minutes for Final Spin.

Bath "IS"

The owner can change the displayed value, but for a coin washer only 0 will be put into the cycle.

Washer 6 Default Cycles (Preset at Factory)

There are 6 pre programmed baths on the control which are set up at the factory. The formulas for each are shown on the following pages. Each of these 6 programs can be adjusted and saved as the owner needs.

Cycle 1: Sheets and Pillowcases (Health Care)

Bath	Bath Cycle Time (min.)	Water Temp.	Water Level	Delay Fill	Spin Time (min.)	Injection Source
Flush	3	CH	HI	d		
Prewash	2	CH	HI	d		
Wash	7	HH	LO	d	1	#1(Detergent)
Rinse 1	7	HH	LO	d	2	#2 (Bleach)
Rinse 2	2	CH	HI	d	1	
Rinse 3	2	CH	HI	d		
Rinse 4						
Final Rinse	4	CH	LO	d	4	#4 (Sour/Soft)

Cycle 2: Towels / Pads / Diapers (Health Care)

Bath	Bath Cycle Time (min.)	Water Temp.	Water Level	Delay Fill	Spin Time (min.)	Injection Source
Flush	3	CH	HI	d		
Prewash	2	CH	HI	d		
Wash	7	HH	LO	d	1	#1 (Detergent)
Rinse 1	1	HH	HI	d		
Rinse 2	7	HH	LO	d	2	#2 (Bleach)
Rinse 3	2	CH	HI	d	1	
Rinse 4	2	CH	HI	d		
Final Rinse	4	CH	LO	d	5	#4 (Sour/Soft)

Cycle 3: White Towels (Hotel / Motel)

Bath	Bath Cycle Time (min.)	Water Temp.	Water Level	Delay Fill	Spin Time (min.)	Injection Source
Flush						
Prewash						
Wash	7	HH	LO	d	1	#1(Detergent)
Rinse 1	1	HH	HI	d		
Rinse 2	7	HH	LO	d	2	#2 (Bleach)
Rinse 3	2	CH	HI	d	1	
Rinse 4	2	CH	HI	d		
Final Rinse	4	CH	LO	d	5	#4 (Sour/Soft)

Washer Programming Instructions

THERE ARE TWO WAYS TO MODIFY PROGRAMMING OF THE V-SERIES OPL SIX (6) PREPROGRAMMED FORMULAS

Option 1: Programming can be accomplished manually using the machine controls or by connecting to the machine control using a PDA (personal digital assistant). For instructions on using a PDA with this washer control and software, please contact your local Dexter distributor. Please read below for manual programming instructions.

The keypad layout for the washer control is shown below.

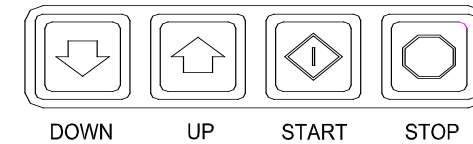

Option 2: Wash Cycle Manually Programming

1. Turn on the power to the washer.
2. Turn the Run/Program key to the Program position. Display will show "CO" and the "ADD BLEACH" will blink and will continue to blink during the programming mode.
3. Press the "DOWN" or "UP" buttons to select which cycle to alter. When the desired cycle number is displayed, press "START".
4. The display should now show a "b". The "b" and the cycle indicator lights indicate which bath is being selected to alter. Press the "UP" and "DOWN" buttons to select a bath to change and then press "START".



The indicator lights are shown above:

When "RINSE" is selected, "b r1" through "b r4" may be selected. **There may be multiple rinses that are indicated by br 1, br 2, br 3, and br 4**

5. Each bath can be programmed with the following options. Use the "DOWN" and "UP" keys to select the desired setting and the "START" key to move to the next option.

To exit the programming of a bath, press the "STOP" button once and use the "UP" and "DOWN" keys select another bath. Press the "STOP" button again to select a different cycle to change. To end programming, turn the key to "RUN" position.

Cycle 4: Guest Laundry (Hotel / Motel / Healthcare)						
Bath	Bath Cycle Time (min)	Water Temp.	Water Level	Delay Fill	Spin Time (min)	Injection Source
Flush	3	CH	HI	d		
Prewash						
Wash	7	HH	LO	d	5	#6(Detergent/Bleach)
Rinse 1	2	HH	HI	d		
Rinse 2	2	CH	HI	d		
Rinse 3	2	CH	HI	d		
Rinse 4						
Final Rinse	4	CH	LO	d	4	#4 (Sour/Soft)

Cycle 5: Rags and Mops (Hotel / Motel)						
Bath	Bath Cycle Time (min)	Water Temp.	Water Level	Delay Fill	Spin Time (min)	Injection Source
Flush	3	CH	HI	d		
Prewash	2	CH	HI	d		
Wash	2	CH	HI	d		
Rinse 1	7	HH	LO	d	1	#1 (Detergent)
Rinse 2	2	HH	HI	d		
Rinse 3	7	HH	LO	d	2	#2 (Bleach)
Rinse 4	2	CH	HI	d	1	
Final Rinse	2	CH	LO	d	5	

Cycle 6: Colored Cotton Linen (Hotel & Food Service)						
Bath	Bath Cycle Time (min)	Water Temp.	Water Level	Delay Fill	Spin Time (min)	Injection Source
Flush	3	CH	HI	d		
Prewash	2	CH	HI	d		
Wash	2	CH	HI	d		
Rinse 1	7	HH	LO	d	1	#1(Detergent)
Rinse 2	2	HH	HI	d		
Rinse 3	7	HH	LO	d	2	#2 (Bleach)
Rinse 4	2	CH	HI	d	1	
Final Rinse	2	CH	LO	d	5	

MAXIMUM SPIN SPEED ADJUSTMENT (T-950 Only)

The variable frequency drive allows for varying acceleration during Final Spin on T-950 models. It is important to utilize a decreased acceleration rate when the application power is low. This acceleration rate is determined by a white wire jumper installed on the drive terminal block from +10V to AVI.

Remove the wire jumper when input power is between 208 and 219 volts. Keep the jumper installed when input power is between 220 and 240 volts. Reference the drawing below for the jumper location.

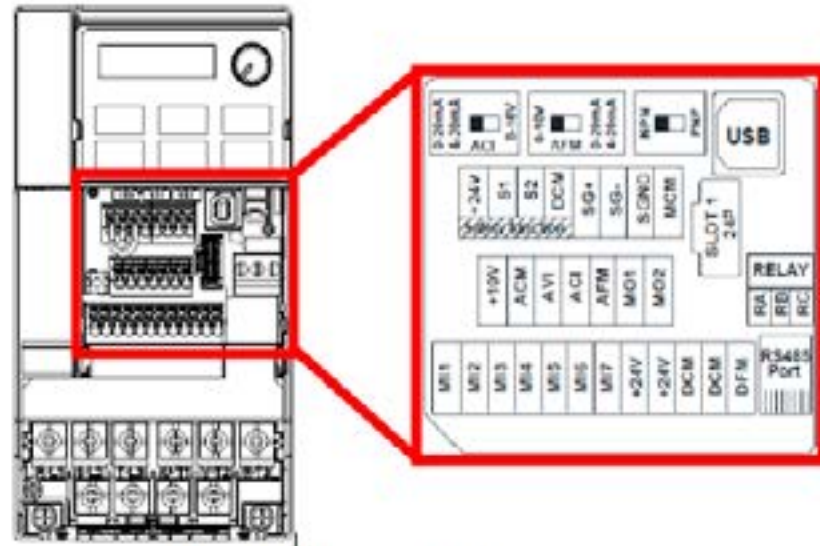

Control Terminations on Variable Frequency Drive

V Series Washer Model	Input Voltage	Max Spin Speed	Jumper Terminal Locations on Variable Frequency Drive (VFD)													
			M1	M2	M3	M4	M5	M6	DCM (Left)	DCM (Right)	24V	ACM	AVI	ACI	10V	MO1
T-950	240V	140 G	REMOVE Brown Jumper Between M5/M01													
		200G												X		
	208V	140 G	REMOVE Brown Jumper Between M5/M01													
		200G	No Jumper required													

T-950 Spin Speed Adjustment Jumper Locations

Section 4:

Trouble Shooting

Common Troubleshooting Solutions

Symptom	Probable Cause	Suggested Remedy
Machine does not start	Power Supply	Check these areas: Circuit breakers, Voltage, Power leads, Power connections. Is front display LED display lit?
	Door Switch	Check for continuity through door switch when door is closed. If no continuity, adjust or replace door switch.
	Control Breaker or Fuse	Check the 1.5 amp and 2.0 amp fuses (60 hz models) or circuit breaker (50 hz models) for continuity. If no continuity, replace fuse or breaker.
	Control Transformer	Check voltage output from control transformer for 24 VAC and 120VAC (50 hz models have 24 VAC only). If voltage is incorrect, check for proper transformer tap connection or replace transformer.
	Check PCB board	Check all wire connections for sure contacts.
	Check wiring between PCB	Check data cable phone type connectors unplug and VFD and replug with power removed.
	Check Door Lock Mechanism	Check that 120 VAC power (for 60 hz) or 24 VAC power (for 50 hz) is at door lock motor after start button is pressed.
Door does not lock	Check display for fault code	Follow tests described in fault code section.
	Door locking mechanism	Check to ensure that mechanism is receiving 120VAC for 60 Hz. models (or 24VAC for 50 Hz. models) from main relay PCB. If it is receiving power but not functioning, then replace mechanism.
	Door Switch	Check for continuity through door latch switch when door closed. If no continuity, adjust or replace door switch.
Door will not open	Thermoactuator	Check to see if thermoactuator(s) and/or its mechanism is stuck or binding and not allowing the door lock mechanism to open. Check to be sure that the locking thermoactuator is not receiving 24VAC during the last 1 1/2 minutes of the cycle. Also check to see that the unlocking thermoactuator is receiving 24VAC during the last minute of the cycle. If the timing and voltage are correct, replace the thermoactuator.
Door will not open	Door Rod	Check to see that door rod from solenoid to lock ass'y is long enough to allow lock ass'y to disengage. If not, adjust rod.
	Door locking mechanism	Check that door lock mechanism is not stuck closed. If stuck, replace.
No hot water in detergent dispenser	Water Valve Coil	Check coil continuity at terminals and replace if no continuity. 120 VAC power (60Hz) only on for 20 second in wash bath. (24 VAC for 50 Hz models)
	Water Inlet	Check water inlet screens for blockage and clean screens if necessary.
	Water	Check to insure that water is turned on and operating.
	P-20 Wire Harness	Check black & white harness.

Symptom	Probable Cause	Suggested Remedy
Hot water does not enter tub in wash	Water Valve Coil	Check coil continuity at terminals and replace if no continuity. Check for 120 VAC power (60 Hz) from main relay PCB. (24 VAC for 50 Hz models)
	Water Inlet	Check water inlet screens for blockage and clean if necessary screens
	Water	Check to insure that water is turned on and operating.
	Check Voltage	If appropriate voltage is not present at the valve, refer to the wiring diagram for your specific washer model. Check for voltage at the P4 Connector on the Relay PCB. Check for LED indication that the appropriate relay is activated.
No cold water to tub in wash	Pressure Switch	Check pressure switch continuity between terminals . If no continuity, check pressure switch hose for obstruction. If hose okay, change pressure switch.
	Water Valve Coil	Check coil continuity at terminals and replace if no continuity.
	Water Inlet Screens	Check water inlet screens for blockage and clean if necessary.
	Water	Check to insure that water is turned on and operating.
	Check Voltage	If appropriate voltage is not present at the valve, refer to the wiring diagram for your specific washer model. Check for voltage at the P4 Connector on the Relay PCB. Check for LED indication that the appropriate relay is activated.
	Pressure Switch	Check pressure switch continuity between terminal contacts. If no continuity, check pressure switch hose for obstruction. If hose okay, change pressure switch.
Water comes in but level does not rise	Drain Valve (open)	Check these areas: <ul style="list-style-type: none"> • Drain valve blockage • Drain valve motor and gear train. If power but drain valve does not close, replace valve. • Power to the drain valve. If no power to drain valve, check circuit for power.
	Check Voltage	If appropriate voltage is not present at the valve, refer to the wiring diagram for your specific washer model. Check for voltage at the P4 Connector on the Relay PCB. Check for LED indication that the appropriate relay is activated.
Water does not flush softener compartment.	Water Valve Coil	Check coil continuity at terminals and replace if no continuity.
	Water Inlet Screens	Check water inlet screens for blockage and clean if necessary.
	Water	Check to insure that water is turned on and operating.
Water does not flush softener compartment.	Pressure Switch	Check pressure switch continuity between terminals. If no continuity, check pressure switch hose for obstruction. If hose okay, change pressure switch.
Water level too high	Pressure Switch	Check for blockage in pressure switch hose. Check for pressure switch opening circuit across terminals . Replace switch if contacts do not open.
Water drains slowly	Drain System	Check hoses and drain valve for blockage. Clean of inadequate size. If necessary. Check building drains for blockage

Common Troubleshooting Solutions

Symptom	Probable Cause	Suggested Remedy
Machine does not turn	VFD	Check VFD by removing inspection panel and record any numbers or letters displayed. If no display turn power off to machine at breaker for 2 minutes and turn power back on to reset. If still no display replace VFD
Machine tumbles in one direction	VFD	Remove inspection cover at rear and record in only numbers or letters displayed. See fault code section for more info.
	VFD	Inspect yellow enable wires from main relay PCB and at VFD
Excessive vibration	Mounting System	Check these areas: • Strength of mounting structure, concrete or base. • Mounting bolts may be loose and need tightening.
	Drive Belt	Worn drive belt can cause vibration and noise.
	Loading	Note: Small loads contribute to out of balance loading and increase vibration.
	Code	Reset code by: 1. From "READY" screen, press the UP button to "Management View" then Enter (green arrow). 2. Enter passcode - Default is 0000. Choose "Confirm". This will enter Programming Mode. 3. Arrow down to General Settings and hit enter. 4. Change or verify it says "READY" to the right of Excessive Vibration (up/down arrows will let you change the option) then enter. 5. Scroll back up to "Back" and confirm. 6. Proceed to back out of programming until you are to the "READY" screen with program options.
Machine does not spin	Pressure Switch	Check pressure switch for continuity across terminals #21 & #22 indicating pressure switch has reset to the empty position. If no continuity, change pressure switch.
Machine starts and does not operate	VFD	Check yellow enable wires from relay PCB P13 & motor P14 to VFD advances through cycle are connected. Check fault code on VFD before removing power from the drive. Check orange P-15 wire for signal from door switches.
Machine does not stop	Main PCB	Main PCB controls time cycle at end of cycle
	Braking Resistors	Check braking resistors for continuity. Verify ohms resistance by Molex.
Water leakage around loading door	Door Adjustment	Door may need adjustment due to abuse or wear. Check tightness around perimeter using a dollar bill. Adjust left to right tightness by shims at door lock or hinge side. It is important to center gasket to tub opening before tightening door to hinge bolts. Chalk may be used on tub front to show point of contact with tub. If gasket is deformed, worn, or damaged, replace. Refer to parts section for door gasket expander kit.

Fault#	Description	Customer Action
HEAT_RISE_OUT_OF_RANGE	Operating temperature is above (target temperature + upper hysteresis) and above 220F (104C)	Check operating thermistor
NO_HEAT_RISE	Operating temperature is below (target temperature + lower hysteresis) and operating temperature has not increased by 2F in 15 minutes	Check operating thermistor Check gas Check combustion
PROX_SENSOR_OUT_OF_RANGE	This error occurs when the machine control sees output from the proximity sensor(s) that does not fall in the acceptable range for the particular washer or dryer model running at normal speeds. It also occurs when the machine control sees output from the proximity sensor that implies the tumbler is still turning when the control has commanded it to Stop.	The machine will not start and the Error Code will continue to be displayed until the prompt is followed to Reset the Error Code and return the Machine to Idle Mode.
NO_PROX_SENSOR_OUTPUT	The RPM is below 10 after the VFD is within 10% of its commanded frequency for 3 seconds	Check belts Check Prox Sensors
BL_COMMAND_ERROR	The control board received a bootloader command but was unable to complete the operation requested	Hold reset button for 10 seconds to force control board into the actual bootloader.
THERMISTOR_SHORT	There is a short circuit across the thermistor terminals or the measured temperature is above 385 degrees F (below 100 ohms).	Check Thermistor connections Check Thermistor resistance
THERMISTOR_OPEN	There is an open circuit across the thermistor terminals or the measured temperature is below -33 degrees F (above 310 Mohms)	Check Thermistor connections Check Thermistor resistance
OH_THERMISTOR_SHORT	There is a short circuit across the thermistor terminals or the measured temperature is above 440 degrees F (below 50 ohms).	Check OH Thermistor connections Check OH Thermistor resistance

Fault#	Description	Customer Action
OH_THERMISTOR_OPEN	There is an open circuit across the OH thermistor terminals or the measured temperature is below -33 degrees F (above 310 Mohms)	Check OH Thermistor connections Check OH Thermistor resistance
DRIVE_COMMUNICATION_ERROR	Failure to reset VFD, communication retry failure over 3 times	Check VFD cable Check VFD power
DRIVE_CRC_MISMATCH_ERR	CRC mismatch in VFD message	Check VFD FW Check VFD cable Check for noise on VFD cable
DRIVE_ENABLE_ERROR	VFD speed still 0 after commanding frequency 3 times	Check VFD enable relay Check VFD enable connector Check VFD enable cable
DRIVE_EXCEPTION_ERROR	Exception received from VFD	Refer to Graphics board for specific exception
SLOW_SPIN_ERROR	VFD frequency is not within 10% of the command frequency after time specified by acceleration type	Check VFD load
DRIVE_RESETTING	Temporary warning indicating that the drive was commanded to reset	Check VFD FW Check VFD cable Check for noise on VFD cable
DRIVE_RESET_COMPLETE	Warning used to indicate a VFD reset was successful	No Action Required
MODEL_DRIVE_SIZE_ERROR	VFD size does not match machine configuration parameters	Check model header Check model configuration
DRIVE_PARAMETER_ERROR	VFD parameters not match machine configuration parameters	Check model header Check model configuration
NON_DEXTER_DRIVE	Failed to validate Dexter Drive	Check VFD model
SPIN_TIME_ERROR	VFD frequency is not 0 after time specified by deceleration type	Check VFD Check Drum
VFD_FAULT	Fault detected on VFD	Check Graphics board for which fault
VFD_HARD_ERROR	Unknown error returned from the VFD	Check VFD

Fault#	Description	Customer Action
PORT_EXP_INIT	Could not initialize port expander(s)	Check I2C connections
PORT_EXP_READ	Could not read port expander	Check I2C connections
PORT_EXP_SET	Could not set output on port expander	Check I2C connections
PORT_EXP_OLAT	Could not latch output on port expander	Check I2C connections Check voltage on output pins of port expander
PORT_EXP_BAD_CONTROL	Control register mismatch on port expander or issue writing to control register	Verify Relay board was not reset without control board
PORT_EXP_FAILURE	Output register mismatch on port expander	Verify Relay board was not reset without control board
MODEL_CONN	Model connector missing or invalid	Check model connector
OVERHEAT_ERROR	Overheat condition detected	Check Overheat thermistor Check operating temperature thermistor
POWER_LOSS_ERROR	Power loss condition detected	Check power cable Check power to control board
SLOW_FILL_ERROR	Water level has not reached desired level when filling for 15 minutes	Check water supply Check water valves Check water valve relays Check pressure sensor

Fault#	Description	Customer Action
SLOW_DRAIN_ERROR	Water level has not reached empty level when draining for 5 minutes	Check water drain Check drain valve Check drain valve relay Check pressure sensor
INVALID_FILL	Fill type specified does not match available types	Contact software engineering. Indicative of software bug or processor malfunction
DOOR_SHUT_NOT_LOCKED	Unable to lock door when starting washer cycle. Unable to keep door locked when running a cycle	Check door lock motor Check door lock relay Check thermoactuators
INCOMPATIBLE_SPIN_SPEED	Spin type specified does not match available types	Potential model mismatch between control board and graphics board, reset machine.
THERMAL_LOCK_FAIL	Unable to hold the door locked when testing between stages	Check thermoactuators
PORT_EXP_I2C_ADDR	Could not find the expected port expander with the proper address configured	Check I2C connections Check Relay Board model connectors P6
INJECTION_ERROR	Improper injection or injection times	Check cycle parameters
INVALID_PARAM	Invalid parameter received from Graphics board	Check model parameters
VFD_RESET_FAIL	Failed to reset the VFD	Check VFD
	VFD speed is outside of 10% window of commanded speed	Check VFD
E_STOP	Emergency Stop button depressed	Check E-stop button

OPL Drive Motor Inverter Type Motor-Winding Resistance Chart

T-1800 6-Cycle Washer

Motor	Winding	Wire #	Resistance	
			Minimum	Maximum
T-1800 1ph or 3ph 60hz Main (wash & spin)		T1 & T2	0.944	1.097
Dexter #9376-328-002		T2 & T3	0.944	1.097
Marathon #		T1 & T3	0.944	1.097

NOTE: Resistance values are measured at the stator. Values at the end of the motor wiring harness may be slightly higher.

Top Panel Removal

- Step 1:** Remove 4 screws that hold detergent dispenser to top panel. If front soap dish go to step 2
- Step 2:** Unlock top panel lock with the 6324 key.
- Step 3:** Raise top panel, slide to the rear to release from back clips and lift off.



Front Panel Removal

- Step 1:** Remove the loading door by first removing the two lower screws of the lower hinge clamp and lifting the door off of the hinge assembly.
- Step 2:** Remove 2 screws between front panel top and front (located behind control panel).
- Step 3:** Remove the two screws in the middle of the front panel.
- Step 4:** Pull panel out at the bottom to about a 45 degree angle to detach the top lip and remove.

Back Panel Removal

- Step 1:** Remove all screws holding back panel in position except the bottom row.
- Step 2:** The bottom row of screws are slotted and only need to be loosened and to lift off panel.

NOTE: The back panel is not only a safety requirement but also contributes to the rigidity of the cabinet.

Drain Valve Access

For access to drain valve, remove lower service panel. The drain valve is a ball type and is powered closed by the drain valve motor. It is mounted under the washer tub on the left side. It is spring loaded open. If power is interrupted to the washer, the motor releases the sealing ball, allowing the drive spring to open the valve. With the valve open, all water in the washer will drain out.



Drain Valve Cleaning

- Step 1:** Loosen the clamp on the tub hose at the drain valve end and remove the hose from the drain valve.
- Step 2:** Loosen the drain hose clamp on the back of the drain valve. Remove two drain valve mounting racket screws from the frame of the washer.
- Step 3:** **Disconnect red & black wire connection at clear connector.**
- Step 4:** Remove the drain valve and bracket assembly. Unplug the wiring after the drain valve is removed from the washer.

Vacuum Breaker (also called an air gap)

In the left rear of the cabinet is the vacuum breaker. It guides the water to the tub and dispenser and prevents a back flow of water.



Water Valves

Remove top panel to access water valves. (see Removing Top Panel)
The two dual outlet water valves are mounted to the water valve mounting plate that is fastened to the rear channel. To remove the valves, loosen the 2 locking nuts on both sides of the mounting plate from the interior of the machine and then lift the plate and valves off of the back channel and pull the assembly into the machine. The valves can then be removed from the mounting plate by removing the 5/16 mounting screws.



Always check inlet screens to be sure that they are clean. Disassembly requires the removal of two solenoid screws and three valve body screws. Below the solenoid coil is a solenoid guide, armature, armature spring and diaphragm. All valve parts are available individually or as a complete unit.

Door Lock Assembly Operation

After loading the clothing, the door should be closed and latched. The locking cam on the door contacts the latching switch actuator which closes the latching switch. The specified number of coins should now be added to start the washer. The gear motor pulls up on the locking pawl by use of a linkage rod. The locking pawl has two jobs. The first is to lock the door. This is accomplished by blocking the locking cam on the door so that it can't rotate to unlock. The second job is to close the two piggyback lock sensing switches. These switches control power to all of the controls. If the door unlocks for any reason, these two switches will stop the machine. When the door handle is 1/4 to 1/2 of an inch from its fully closed position, the latching switch should close. The two piggyback lock sensing switches should be open when the door is unlocked and should be closed when the door is locked.

Accessing the Door Lock Assembly

After removing the front panel and masking ring, the door lock assembly can now be accessed.

Adjustment for Door Lock Assembly

The latching switch and the piggyback lock sensing switches all have slotted mounting for easy adjustment.

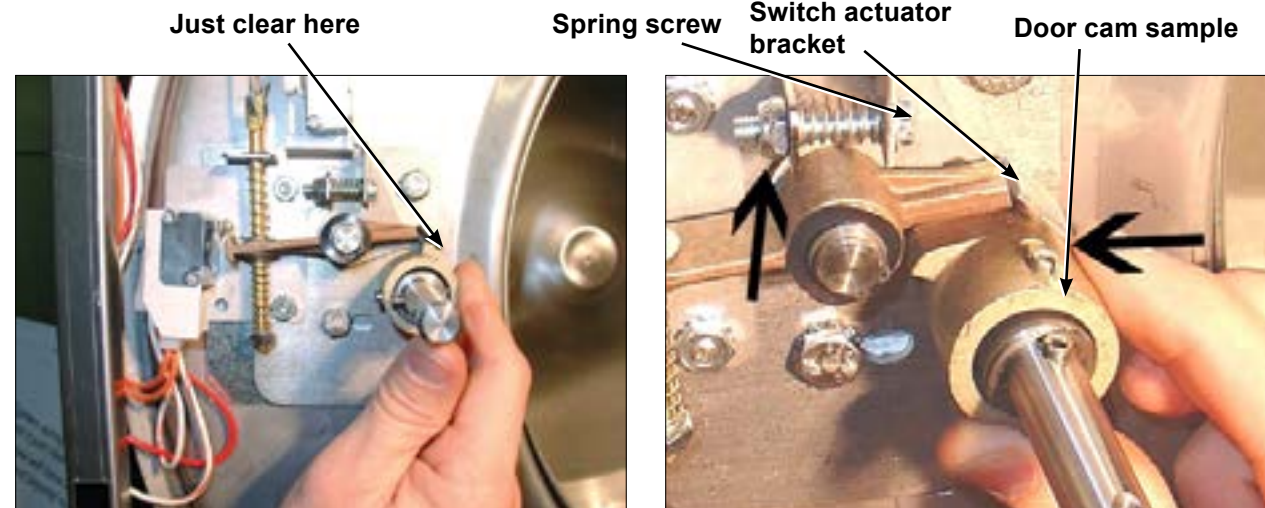

Step 2: Tighten spring screw on switch actuator bracket arm until it just clears cam OD. at base of door lock assembly.

Adjustment to this bracket usually is not necessary as next step is used more in field.

Flat blade screw on door switch latching



Step 3: With switch actuator bracket adjusted you will now need to adjust single switch by loosening 2 flat blade screws and allowing swivel of switch. Move switch towards above bracket until it actuates. Now tighten flat blade screws. Use a .040 thickness guage to insert between bracket and switch and the switch should close and open again upon removal of thickness guage.

Door cam check position

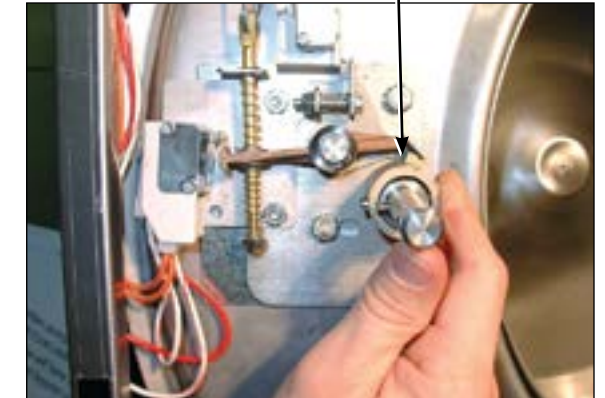

Step 4: Check for switch actuation at partial turn of cam as in operation above. Door handle goes from horizontal to six o'clock vertical.

Door lock rod Locking pawl blocking

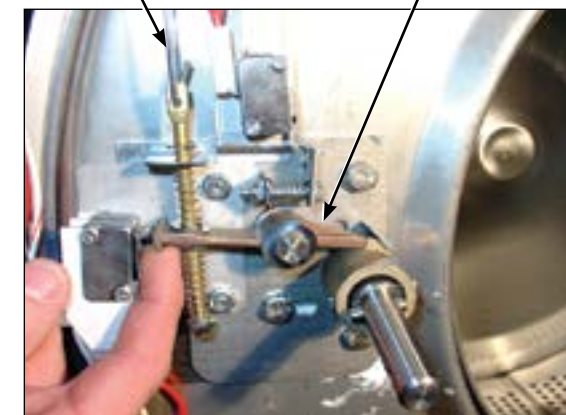

Step 5: Check that lock pawl arm swings to cam lobe to lock position.

Adjustment screw for (piggyback switches)

Top flat end of locking pawl.

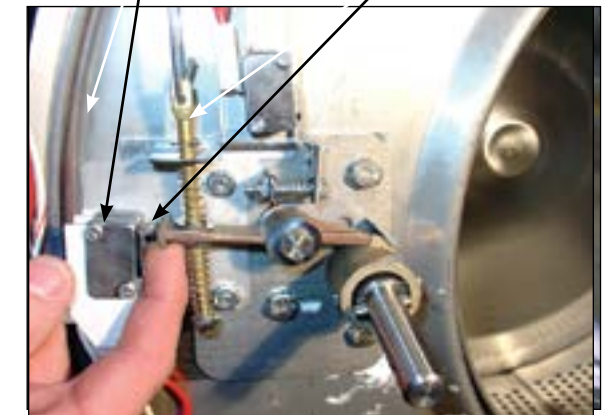

Step 6: The lock stacked switches (piggyback) must be adjusted as door lock solenoid pulls up on door rod and locking pawl is now blocking door cam from turning and is in full up position. The stacked switches (piggyback) have a single actuator arm and it must actuate when single actuator roller wheel rolls to flat side of locking pawl. You will also notice a .040 gap between actuator arm and switch bodies.

Note: Both stacked switches must operate together!

Adjusting the Loading Door

The door can be adjusted by changing the number of shims behind the door hinge and the door lock assembly. The vertical fit of the door to the tub can be altered by loosening the door hinge bolts and raising or lowering the door before retightening. It is important for the door to be centered on the tub front. By chalking the front of the tub and closing the door to transfer that line to the gasket, the centering can be evaluated. It is also important for door pressure to be similar around the door perimeter. Door pressure can be evaluated by inserting a dollar bill in several positions and tugging on it. See Parts Section for kit to increase door sealing pressure.

Loading Door Removal



Step 1: Support door to prevent dropping.



Step 2: Remove the bottom 2 bolts holding the lower leaf hinge and then remove it. The door can now be lifted from the upper post of the hinge assembly.

Loading Door Hinge Removal

Step 1: First remove loading door and front panel.

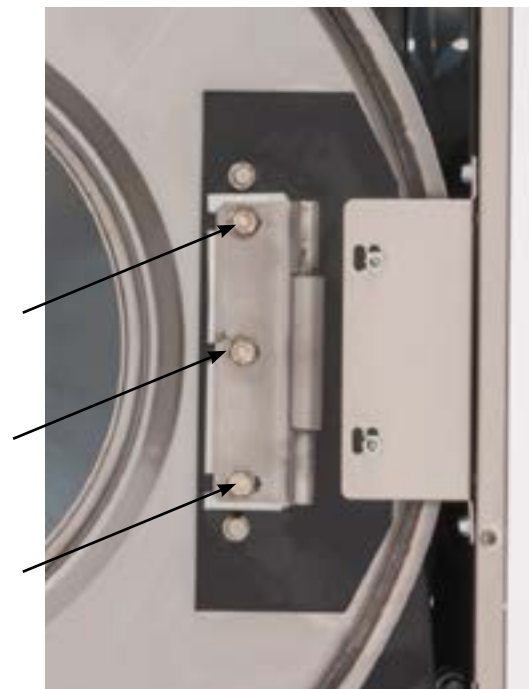

Step 2: Remove 3 screws holding door hinge. Shims may be present between hinge and tub front. The number may be increased or decreased to adjust right side door pressure.

NOTE:
Door hinge mounting bolts penetrate tub front and require silicone sealer applied to holes when reinstalling.

Loading Door Disassembly

Step 1: Remove the loading door as outlined above. Lay the door on a flat surface with the glass down.

Step 2: While holding down on the door glass, lift up on the door ring and roll back the lip of the gasket with your fingers.

Step 3: Work all the way around the gasket and the glass is out.

Loading Door Reassembly

Step 1: Lay the door ring face down on a flat surface. Start the glass into one side of the door gasket.

Step 2: Use one hand underneath to push the gasket out and the other hand on the top pulling the gasket in place.

Step 3: The front lip of the door gasket should be checked for proper seating.

Control Panel Name Plate Decal

The name plate on washer front is adhesive backed.

Control Panel Name Plate Removal

The name plate may be removed by simply peeling it off.

Re-Installation of Name Plate

Step 1: Remove any remaining glue from the control panel.

Step 2: Before removing the paper backing from the name plate, check fit to the control panel. The program push buttons are the locating guides.

Step 3: Remove the paper backing from the right side of the name plate, position it on the panel and press right end into place. Peel the backing from the left end and press into place.

Outer Cabinet Removal

T-1800

Removal of Cabinet T-1800

- Step 1:** The power supply, water hoses, and drain connection must all be disconnected before proceeding with the disassembly.
- Step 2:** Now remove the lower service panel and the top panel assembly.
- Step 3:** Remove the left and right lower front panel screws that retain the panel to the chassis.
- Step 3:** Remove the bottom row of back panel screws.
- Step 4:** Remove the loading door.
- Step 5:** Remove the four 7/16 nuts along the bottom of each side panel straps. When reinstalling these screws do not overtighten.
- Step 6:** Disconnect the door lock wires from all switches and the door lock gear motor.
- Step 7:** Disconnect pull rod between gear motor and door lock assembly. Disconnect the wires to the dump valve at the bottom of the machine.
- Step 8:** Disconnect the wires to the drive motor from the VFD T1, T2, T3.
- Step 9:** Remove the clamp and the hose from the vacuum breaker where it connects to the inlet on the back of the tub.
- Step 10:** Remove the pressure switch hose from the bottom of the switch.
- Step 11:** It should now be possible for two people to lift the cabinet up and off of the front of the machine and set it aside.

Door Locking Gear Motor Assembly

The door locking gear motor is rotated shut with control voltage to lock the door and releases when voltage is removed. It is located in the left front corner of the washer.

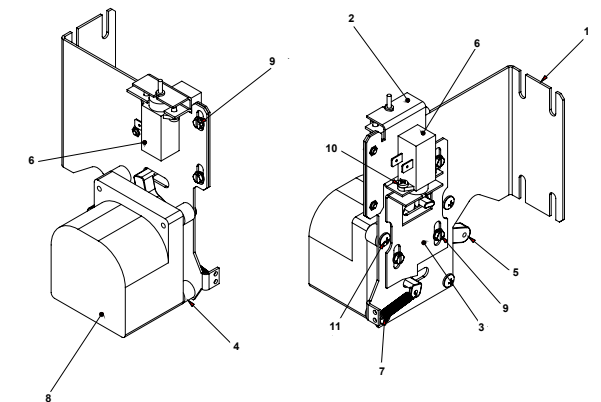

Door Lock Gear Motor

Thermoactuators

The thermoactuators are a safety device that keeps the door from immediately unlocking if power is lost while the machine is operating. They are mounted under the door locking gear motor.

Lock Thermoactuator

Control voltage is applied to the lock thermoactuator at the beginning of the cycle making it extend and block the door locking gear motor. This keeps the door locked for approximately two minutes after a power failure occurs. The lock thermoactuator does not delay the door opening at the end of a normal cycle.

Unlock Thermoactuator

To insure that the lock thermoactuator has retracted by the end of the cycle, one minute prior to the end of the cycle, the unlock thermoactuator is powered with control voltage making it extend and unblock the door locking gear motor.

Drive Belt Removal

Turn the drive pulley while applying pressure to the drive belt until it rolls off of the basket pulley first and then remove from the motor pulley. Be cautious not to drop the motor which could unhook the tension assembly.

Reverse this procedure for installation.

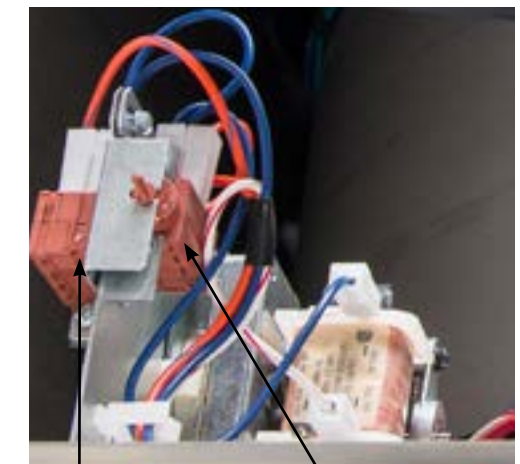

Unlock Thermoactuators Lock Thermoactuators



Drive Belt

Cylinder

- Step 1:** Remove the top panel as described previously.
- Step 2:** Remove lower service panel as described previously.
- Step 3:** Remove front panel as described previously.
- Step 4:** Remove masking ring as described previously.
- Step 5:** Remove door lock assembly. (Leave wires & pull rod in place)
- Step 6:** Remove clothes door.
- Step 7:** Remove tub front clamp ring.
- Step 8:** Remove tub front. Use a flat screw driver to pry the tub front loose.
- Step 9:** Remove the rear access panel.
- Step 10:** Remove the drive belts.
- Step 11:** Remove drive pulley. Remove 3 retaining screws. Insert (3) 3/8 16 x 2" screws into the threaded removal holes. Alternately tighten these screws evenly to pull the pulley off.
- Step 12:** Remove pulley hub. Drive a flat screw driver into the slot in the hub and pull it from the shaft.
- Step 13:** Install cylinder puller. (Snap On part #CJ-84-C) Be sure to thread a 5/8-11 NC bolt into the end of the cylinder shaft to protect the threads. Push the basket out.

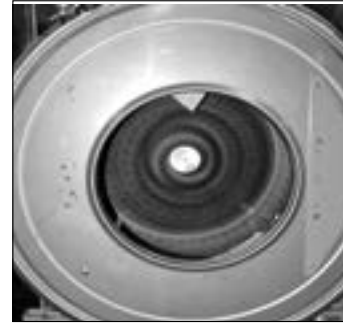

Bearing Housing Assembly

Removal

- Step 1:** Remove cylinder from washer (see Cylinder (basket) removal).
- Step 2:** Remove 6 7/16" tub back to bearing housing cap screws.
- Step 3:** Remove 6 3/4" bearing housing to frame bolts.
- Step 4:** Remove bearing housing from frame.
- Step 5:** Remove the retaining ring next to the front bearing.
- Step 6:** The bearings are pressed into the housing and must be pressed back out.



Reassembly

- Step 1:** When installing new bearings into a bearing housing, first press the front (large) bearing into the housing until it bottoms and install the snap ring. With the bearing spacer in place, press the rear bearing in until the spacer is snug between the two bearings.

NOTE: If the tub-back water-seal mating ring has been moved it must be cleaned and resealed.



Water Seals

Replacement

- Step 1:** Remove cylinder from washer (see Cylinder (basket) removal).
- Step 2:** Remove water seals from the seal mounting plate on the cylinder shaft. These are removed with your fingers.
- Step 3:** The primary and secondary seals that mount on the sealing ring may be slid over the shaft and seated on the metal sealing ring with your fingers. In the unlikely event that the metal ring that mounts these sealing rings were to be damaged or moved, a new one would need to be pressed on. The seal mounting ring must be pushed against the stop on the shaft. After installing the seals, lubricate the faces of the seals with silicone grease.
- Step 4:** Install cylinder (see Cylinder (basket) reassembly).



Guard Ring & Mating Ring

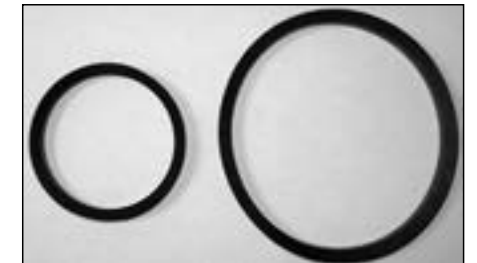

Seals

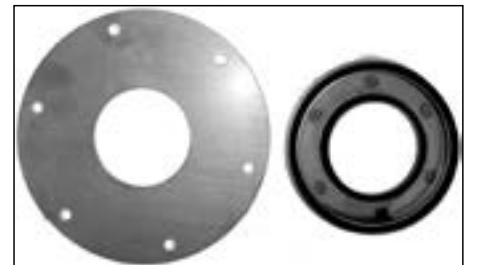

Mating Ring & Mounting Ring

Outer Tub

Removal

- Step 1:** The outer tub can easily be removed when the tub front, cylinder and bearing housing has been removed as outlined previously.
- Step 2:** At that point the only attachments to the chassis are the two front strap mounting bolts.



Reassembly of the Cylinder

- Step 1:** Use the hub of the drive pulley, a stack of 5/8" flat washers and a 3" long 5/8" bolt to pull the cylinder shaft through the bearings. After the 3" bolt a 2" long bolt will be required to finish pulling the cylinder shaft through.
- Step 2:** Remove the 1/2" bolt and nut from the top of the outer tub clamping band.
- Step 3:** Install Dexter Tool part # 8545-056-001 on the back of the outer tub to adjust tub front to cylinder clearance. Thread 5/8" bolt through tool and into cylinder shaft. Push the outer tub forward 1/4" to 1/2" with tool 8545-056-001 by tightening the 5/8" bolt. This will ease the installation of the outer tub front.
- Step 4:** Clean the silicone rubber off the tub front and the outer tub.
- Step 5:** Install new bead of silicone rubber on tub front.
- Step 6:** Install tub front.
- Step 6A:** Align hole in top of tub front with notch in top of outer tub.
- Step 6B:** Use 4-6 #11R vise grip clamps to hold tub front to outer tub. A rubber mallet may be needed to properly seat the tub front into the outer tub.
- Step 6C:** Install tub front gasket around outer edge of tub front and outer tub flange. The opening should be centered at the top.
- Step 6D:** Remove vise grips. The tub front gasket will hold the tub front in place.
- Step 7:** Install tub front clamp ring and tighten. Tap around the clamp ring with a rubber mallet to seat the ring and gasket while tightening the clamp ring bolt.
- Step 8:** Adjust clearance between the outer tub front and the front lip of the cylinder to 5/16".
- Step 9:** Tighten the outer tub clamping band.
- Step 10:** If necessary, the outer tub may be adjusted up or down and side to side with the 2 bolts that fasten the bottom of the outer tub clamping band to the frame.
- Step 11:** Remove Dexter Tool part 8545-056-001 from the back of the outer tub.
- Step 12:** Install drive pulley.
- Step 12A:** Install hub on cylinder shaft.
- Step 12B:** Hold hub against rear bearing with 5/8" bolt and flat washer in end of cylinder shaft.
- Step 12C:** Line up 3 unthreaded holes in pulley with the 3 threaded holes in hub.
- Step 12D:** Insert 3 pulley bolts and tighten evenly alternating bolts to 30ft/lbs.
- NOTE: Overtightening or uneven tightening can break drive pulley.
- Step 13:** Install drive belts & back panel.
- Step 14:** Install door lock. All mounting holes should be sealed with silicone rubber.
- Step 15:** Install door, masking ring, front panel, lower service panel and top.

T-1800 Bolt Torque Chart

Bolt Size	Where Used	Torque
1/2-13 x 2"	Tub Feet To Base	70-110 ft-lb
3/8-16 x 3"	Front Clamp Ring Ends	100-120 in-lb
7/16-14 x 1"	Bearing Housing To Tub Back	60-80 ft-lb
7/8-9 x 3-1/2"	Bearing House To Base	600-650 ft-lb
3/4-10 x 1-1/2"	End Of Shaft	120-130 ft-lb
3/8-16 x 2"	Drum Pulley Bushing	28-32 ft-lb
1/4-20 x 1"	Motor Pulley Screws	80-90 in-lb
#10-32	Soap Box Nuts	10-20 in-lb

Section 6: Service Electrical Components

Control Mounting Trough

Remove top panel to access control trough. (see Removing Top Panel) It sets on the right side of the machine and holds the control PCB's, transformers, and pressure switch.

Main Data Communication Cable

Goes between front PCB board and Variable Frequency Drive unit mounted center rear of machine. It has telephone type connectors at each end and is inserted at Controller PCB and the Variable Frequency Drive.

Circuit Breaker/Fuse

The fuse (optional circuit breaker) mounts to the rear channel. It carries all of the controls in the machine but does not include the motor. To reset the circuit breaker just push in the button. If you have a fuse then remove fuseholder and fuse and replace with a 1 1/2 amp fast blow type fuse.



Fuse Location

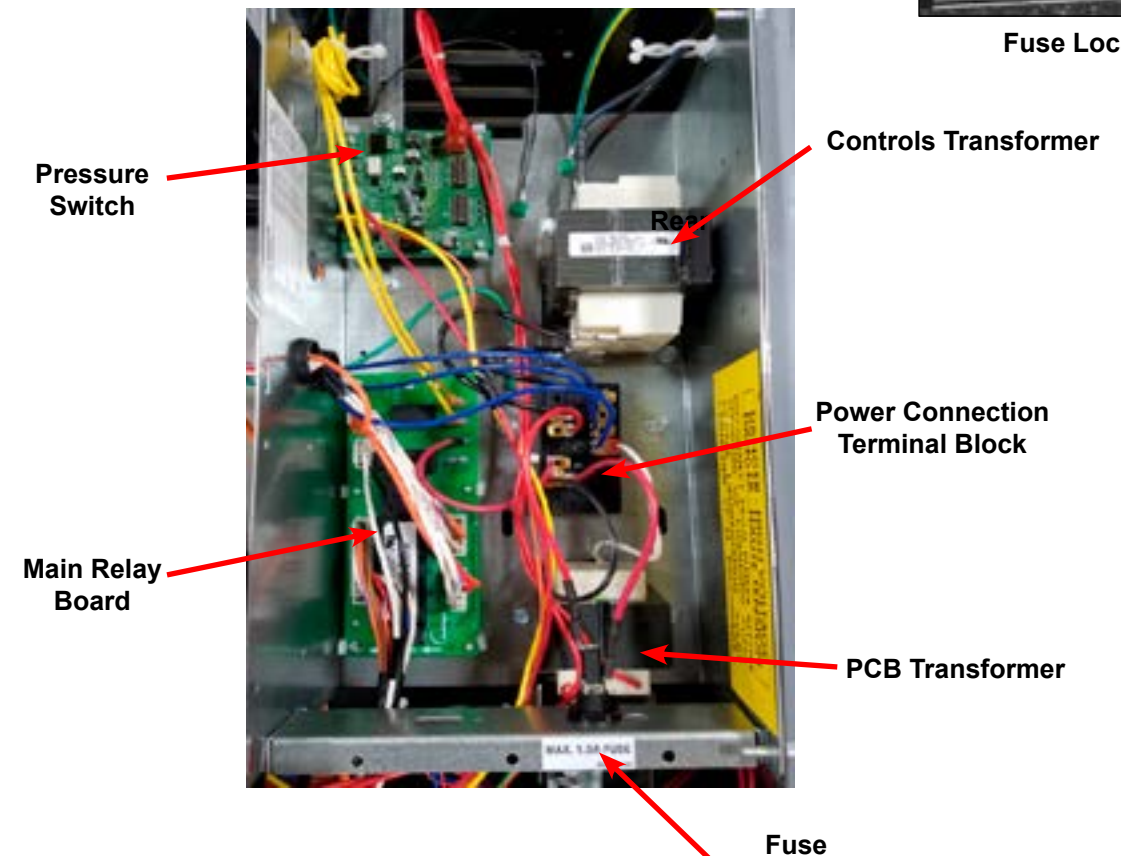

Main Control Printed Circuit Board

Please be sure to be grounded to machine before removal of this board from machine. PC board mounted vertically behind front control panel. Remove hold down nuts in 4 corners and 1 at bottom center.

PCB Transformer Step-down

Small transformer mounted at front of control trough that is powered with 120 VAC primary and two secondary outputs of 2.3 VAC and 24-27 VAC.

Controls Transformer

This transformer is mounted at the back of the control trough and steps a range of 208 to 240 volts down to 120 volts for the controls. There are two terminals on the controls transformer for incoming power. One terminal tap is marked for 208 volts use this tap for measured voltage of 208 volts - 219 volts, and the other tap is marked 230 volts for 220 volts - 240 volts. Note: All washers have a controls transformer. Always check the incoming voltage and use the appropriate transformer terminal when installing ALL washers.

Main Relay Printed Circuit Board

Please be sure to be grounded to machine before removal of this board. PCB mounting horizontal in control trough towards front of machine. Remove 4 mounting nuts.

LED Printed Circuit Board Temperature & Start Display/ Push-Button

The selector switch is mounted in the center of the control panel and is held in place with five nuts. It allows the selection of hot, warm or cold water temperatures. Note: Do not over tighten on reinstallation as the switch can be damaged, stay pushed in and will cause erratic displays.

Emergency Stop Button Switch Assembly

The stop button is mounted on right side of machine. Remove the top and access the rear of button. Remove the plastic retainer by unthreading CCW. The switch assembly will have to be removed by pressing down on the plastic clip while pulling the switch body away from the stop button.



Temperature and Start Display



Stop Button Switch Assembly

Power Connection Terminal Block

This terminal block sets at the very back of the control trough. Incoming power to the washer should connect here. (see Electrical under Installation and Operation Section for exact connections)

Rear



Electronic Pressure Sensor

The Electronic Pressure Sensor comes standard on all models starting September, 1st 2015. Machines manufactured before this date can be upgraded with Kit 9732-213-001. The Pressure sensor is adjustable. The Factory settings chart will let you know the starting values for each machine and by following the Switch position chart you can adjust the water levels in 1/4 inch increments from that starting value.

Factory Settings:

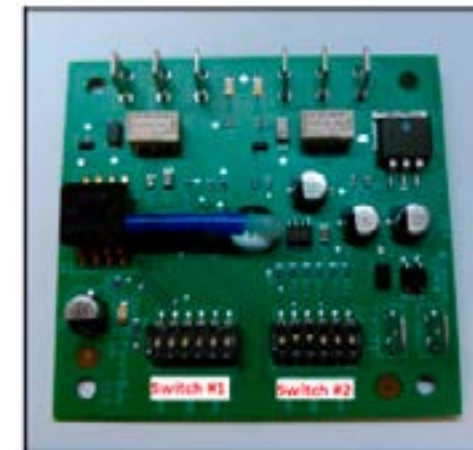

Model	Vended				On-Premise			
	Switch #1 Efficient Inches (mm)		Switch #2 Classic Inches (mm)		Switch #1 Low Level Inches (mm)		Switch #2 High Level Inches (mm)	
T-300	5.25	(133)	7.00	(178)	6.00	(152)	6.75	(171)
T-350	5.25	(133)	6.25	(159)	6.00	(152)	6.75	(171)
T-350 SWD	5.25	(133)	6.25	(159)	6.00	(152)	6.75	(171)
T-400	7.00	(178)	9.00	(229)	8.00	(203)	11.00	(279)
T-450	6.00	(152)	6.25	(159)	6.00	(152)	8.50	(216)
T-450 SWD	5.00	(127)	7.00	(178)	6.00	(152)	8.50	(216)
T-600	7.25	(184)	9.25	(235)	8.00	(203)	11.00	(279)
T-650	6.50	(165)	8.25	(210)	8.00	(203)	11.00	(279)
T-675	-	-	-	-	8.00	(203)	11.00	(279)
T-750	6.00	(152)	7.50	(191)	6.00	(152)	8.75	(222)
T-750 SWD	9.25	(235)	11.75	(298)	9.25	(235)	11.75	(298)
T-900	6.00	(152)	7.50	(191)	6.00	(152)	8.75	(222)
T-950	6.00	(152)	7.50	(191)	6.00	(152)	8.75	(222)
T-975	-	-	-	-	6.00	(152)	8.75	(222)
T-1200	6.00	(152)	7.50	(191)	6.00	(152)	8.75	(222)
T-1450	6.75	(171)	7.00	(178)	6.75	(171)	9.50	(241)
T-1475	-	-	-	-	6.75	(171)	9.50	(241)
T-1800	6.75	(171)	7.00	(178)	-	-	-	-

Switch Positions:						
Depth (in):	Pos 1	Pos 2	Pos 3	Pos 4	Pos 5	Pos 6
5.00						
5.25	on					
5.50		on				
5.75	on	on				
6.00			on			
6.25	on		on			
6.50		on	on			
6.75	on	on	on			
7.00				on		
7.25	on			on		
7.50		on		on		
7.75	on	on		on		
8.00			on	on		
8.25	on		on	on		
8.50		on	on	on		
8.75	on	on	on	on		
9.00					on	
9.25	on				on	
9.50		on			on	
9.75	on	on			on	
10.00			on		on	
10.25	on		on		on	
10.50		on	on		on	
10.75	on	on	on		on	
11.00				on	on	
11.25	on			on	on	
11.50		on		on	on	
11.75	on	on		on	on	
12.00			on	on	on	
12.25	on		on	on	on	
12.50		on	on	on	on	
12.75	on	on	on	on	on	
13.00						on
13.25	on					on
13.50		on				on
13.75	on	on				on
14.00			on			on
14.25	on		on			on
14.50		on	on			on
14.75	on	on	on			on
15.00				on		on

Data Communication Cable

Goes between front PCB board and Variable Frequency Drive unit mounted center rear of machine. It has telephone type connectors at each end and is inserted at Controller PCB and the Variable Frequency Drive.

Delta Variable Frequency Drive:

Main power is connected to terminals L1, L2, and L3 on the Delta drive. If the washer is connected to a three phase source, there should be voltage present on all three terminals. If the washer is connected to single phase power, there should be voltage present on terminals.

The voltage should measure 208 Volts to 240 Volts A.C. between phases and connected to if connected to three phase). There is a tolerance of + 10% on the mains voltage (187 Volts to 264 Volts).



Delta VFD Motor Leads:

The wires from the motor are connected to terminals T1, T2, and T3. Since this drive uses pulse width modulation, an accurate current or voltage reading is not possible. Although an accurate current reading is not possible, a balanced current reading should be present while the motor is running.

Delta VFD Dynamic Braking Resistors:

Two, 160 Ohm or 200 Ohm braking resistors (Please check your washer model parts requirements and quantities), are connected in parallel and attached to the drive at terminals B1 and B2. These resistors allow voltage, which is generated by the motor when decelerating, to be dissipated. They will become hot while the motor is slowing down, so care should be taken so as not to come in contact with them. This will prevent an electrical shock and/or a physical burn.



Delta VFD Cooling Fan:

There is a cooling fan attached to the bottom of the Delta drive. This fan will operate when the internal temperature of the drive reaches a predetermined level, the same way the radiator fan in a newer car operates. THE FAN CAN OPERATE ANYTIME POWER IS APPLIED TO THE DRIVE! Remove power to the drive if work is required around the fan.

Electrical Path Circuit Schematics

Start Circuit

Power travels into the machine on L1 & L2 & (L3, if 3 phase used). L1 and L2 provide 208- 240VAC to the controls transformer which steps the voltage down to 120VAC for the controls. (The L1 connection at the controls transformer must be checked at start-up to coincide with machine operating voltage) The 120VAC travels out from the transformer on either [X-1 red wire directly to the 1.5 amp fuse] or [X-1 black/red wire to TB-4 and then through the red wire to the 1.5 amp fuse]. The controls transformer also creates a neutral on the X-2 black/blue wire that connects to TB-1. From the fuse holder, 120VAC travels on the red wire to the #6 terminal on the terminal strip and then through the black wire to another step-down transformer. From the terminal strip the blue wire will provide the neutral for gear motor, thermoactuators and all valves. The white wire provides the neutral from the terminal to the step down transformer.

120VAC is stepped down to 24 VAC (blue wires), 24VAC (red wires), and a yellow center tap wire to the P-7 power connection on the main controller PCB . With the main control PCB now powered, 5VDC will be present between the (2) yellow wires and also the (2) brown wires for the coin switches. Both pairs will now be ready to count coins through the P-2 connection at the control PCB. 26.8 VAC goes out on the black wire of the P-4 connection from the main control PCB to the S5 door closed switch which mounted on the hinge side of the front panel. Closing the door will engage the door closed switches, sending the voltage to the red wire on the S1 door latched switch. Turning the door handle to the vertical latched position closes the S1 door latched switch, returning the voltage to the main control PCB on the white/red wire at the P-4 connection. 26.8VAC is now present at the S2 and S3 door locked switches.

26.8VDC is also at the black and white wires between P-21 at the main control PCB and the P-20 of the relay PCB. This voltage signals the relay PCB that the door is closed and latched making 120VAC available to the relays controlling the door lock gear motor assembly, drain valve and water valves. A continuous 5VDC is sent on the red wire from the P-1 connector on the main control PCB, through the (normally closed) emergency stop button switch and returns on the second red wire back to the P-1 connector. After selecting the temperature, payment is added and the display counts down on the main control PCB display until the vend price is satisfied. The display will change to scroll PUSH START and the green light over the start button will flash. Pressing the start button on the front of the main control PCB signals the relay PCB to lock the door and 120VAC will go to the door lock gear motor on the white/red wire from the P17 connector of the relay PCB. The door lock gear motor engages and pulls up on the door locking rod, locking the door and closing the S2 and S3 door locking switches.

The S2 locking switch is a backup to the S1 latching switch so that once the cycle starts the S1 isn't critical. The S3 locking switch provides 26.8VDC on the orange wire back to P4 connector at the main control PCB and the P15 connector at the relay PCB. This signals that the loading door is closed, locked and safe to continue wash operations. This activates the P-13 and P-14 yellow enable wires to the inverter drive to allow motion. If there is no signal on P-15 (orange wire) there will be no motion of the tub. S1, S2, S3 and S5 door switches are now closed . The green "On" LED and the door lock gear motor (discussed in start circuit) will remain on throughout the cycle.

Fill Circuit-Warm

The relay PCB supplies 120VAC to the brown/yellow wire from P-17 to the drain valve which closes the valve. The lock thermoactuator also receives 120VAC on orange/blue from P17 of the relay PCB. This device prevents the door lock gear motor from dropping out and unlocking during the cycle in the event of a power loss. The 120VAC will cycle on and off keeping the lock thermoactuator engaged until 70 seconds before the end of the cycle. The main control PCB sends data commands to the VFD through the data cable connected at P-6. These commands control the wash basket which will tumble one direction for 12 seconds, pause, and then reverse direction for 12 seconds.

The prewash or wash LED will illuminate at this time, powered through the white wires from the P-3 connection of the main control PCB to the LED printed circuit board. Using the factory preset cycle as an example: The washer fills the tub through the back of the machine with either one or both the C1 cold and H1 hot water valves. From the P19 connection of main relay PCB, 120VAC is sent out on the white/brown wire to the C1 cold water fill valve and the red/yellow wire to the H1 hot water fill valve depending on the temperature selected. After a 90 second delay from the beginning of the wash cycle bath only, the detergent dispenser flushes the detergent into the tub for 20 seconds. This is accomplished when 120VAC travels through the red/orange wire to the H2 hot water valve solenoid. During the machine fill, a 5VDC signal is sent on the red wire from the P5 connection of the main control PCB to the pressure switch contact and returns on the yellow and orange wires to the P5 connection of the main control PCB. When the water level in the basket reaches the preset level pressure, the switch moves the switch contacts to the full or open position. This causes the main control PCB to signal the relay PCB to shut off the water valve coils.

Wash Circuit

Once the machine has achieved it's water level, the wash basket will continue to tumble one direction for 12 seconds, pause, and then reverse direction for 12 seconds. The time on the front display will count down as the bath progresses. The time of the bath is programmable up 15 minutes per bath. Note: When programming cycles, the wash bath must be programmed for 3 minutes or more.

Drain

When the program bath time ends the main control PCB signals the relay PCB to remove 120 VAC power from brown/yellow wire at P17 going to the drain valve. The normally-open, spring-loaded drain valve opens allowing water to exit the machine. This resets the pressure switch back to an empty level and restores the 5VDC connection through the pressure switch from the red wires to the orange and yellow wires.

Rinse 1 & 2

For Rinse 1 & 2, the rinse LED will illuminate, the drain valve will receive 120VAC and close. The basket will fill and tumble the same as the wash bath for the programmed time. The rinse water temperatures are programmable and factory default is cold.

Final Rinse Circuit

The final rinse LED will illuminate, the drain valve will receive 120VAC and close. The basket will fill and tumble the same as the previous baths for the programmed time. The final rinse water temperatures are programmable. Note: When programming cycles, the final rinse bath must be programmed and cannot be set for less than 3 minutes. Also at the beginning of the final rinse bath, the main control PCB will signal the relay PCB to send 120V to the P-19 connector on the white/blue wire to the C2 cold water valve for 20 seconds to flush the fabric softener dispenser.

Spin Circuit

The spin LED will illuminate and the main control PCB sends a signal to the variable frequency drive via the data cable at P6 to VFD RJ-11. The rotation as viewed from front during spin will be counter-clockwise. (The 18lb washers will extract in a clockwise direction) The time of the spin cycle can be programmed. Note: The final spin must be programmed into the final rinse bath and must be programmed for 1 minute or more.

Unlock Thermoactuator and Shake Out Circuit

70 seconds before the end of the cycle the main control PCB signals the relay PCB to remove 120VAC from the orange/blue wire at the P-17 connector on the lock thermoactuator. This allows the lock thermoactuator time to cool and retract by the end of the cycle. To insure that the lock thermoactuator has retracted by the end of the cycle, 1 minute prior the end of the cycle, the unlock thermoactuator is powered with 120VAC through the orange/red wire from the P-17 connector of relay PCB. The unlock thermoactuator moves the complete bracket assembly away from the white door lock actuator allowing it to drop at the end of the cycle, unlocking the door. The basket will come to a stop from spin speed with the assistance of dynamic braking resistors wired to the variable frequency drive. (See wiring diagrams for quantities and resistor ohm values). The washer will then tumble for 45 seconds to let the clothes shake loose from the basket and then stop.

End of Cycle and Door Open Circuit

Once the machine stopped, 3 things occur:

1. The enunciator will signal for 3 seconds letting the user know that it is the end of the cycle.
2. The Display of the Washer will scroll "CYCLE DONE THANK YOU".
3. The main control PCB signals the relay PCB to remove power from the white/red wire at P-17 which allows the door lock gear motor to unlock. When the loading door is opened, the S1,S2,S3,S5 switches are opened. The machine is now ready to accept coins again.

T-1800 Non-Express : 208-240V Schematic

Kits, Assemblies, & Common Parts

Loading Door & Door Lock Components	Part Number
Door Glass Gasket (Large Door)	9206-431-001
Door Handle Only (Large)	9244-091-001
Door Close Switch	9539-492-001
Door Lock Gear Motor Assembly	9892-015-001
Kit - Door Latching Assy. & Cam (replaces original Door Latching Assembly)	9732-347-001
Kit - Door Cam Replacement	9732-346-002
Kit - Locking Pawl Replacement	9732-346-001
Kit - Door Gasket Expander Kit (Small)	9732-139-001
Kit - Door Gasket Expander Kit (Large)	9732-139-002
Electrical Components	Part Number
Transformer, Control	8711-004-001
Transformer	8711-009-001
Main Control Board	9473-004-010
Kit-Replacement, Pressure Sensor (Only)	9732-315-001
VFD & Breaking Resistors Components	Part Number
Breaking Resistor 160 Ohms	9483-004-003
MS 300 VFD Display	9150-058-001
Data Cable (54")	9806-026-002
Drain & Water Valve Components	Part Number
Kit - 3" Drain Valve Seal Replacement	9732-327-001
Drain Valve 3"	9379-202-001
Water Valve (Dual)	9379-183-012
Water Valve (Single Mueller)	9379-194-001
Diaphragm (Dual)	9118-049-003
Diaphragm (Single Mueller)	9118-055-001
Cabinet Components	Part Number
Front Panel Screw	9545-008-014
Front Panel Finisher Washer	8641-585-001
Front Panel Spring Nut	8640-442-001
5/16 Hex Screw, Common	9545-008-026
Top Lock Key #6324	9306-025-001
Cylinder Plug (1.5" Plastic)	9456-041-007

Section 8:

Parts Data

6-Cycle On-Premise

Large Chassis

WN1800XA-12EV4X

Wiring Harness Part # by Model

Key	Description	T-1800	QTY
Control Panel Wiring Harnesses			
*	Wiring Harness, Door Lock		1
*	Wiring Harness, Drain/Thermo/DoorSol	9627-796-002	1
*	Wiring Harness, Relay Board to Control Board (P20/P21)	9627-793-001	1
*	Lock-Run/Program,w/Harness & Key	8650-027-001	1
*	Wiring Harness LED PCB Board to Control Board	9627-797-001	1
Control Trough Wiring Harnesses			
*	Wiring Harness, Water Valve to Relay Board (P19)	9627-795-005	1
*	Wiring Harness, Control Board to Relay Board (P8/P16)	9627-794-001	1
*	Wiring Harness Control Board (P5) to Pressure Switch	9627-958-001	1
*	Wiring Assembly, Terminal Block to Control Transformer (Blk/Red, 8.5")	8220-001-230	1
*	Wiring Assembly, Fuse (Red 7" #36)	9631-381-018	3
*	Wiring Assembly, Terminal Block to Control Transformer (Blk/Blu)	8220-001-231	1
*	Harness, Power Terminal Block	9627-747-005	1
*	Wiring Harness, 15-pin, non-inj	9627-934-001	1
*	Wiring Harness, P23/P15	9627-798-001	1
*	Wiring Harness, P10	9627-799-003	1
Rear Channel Wiring Harnesses			
*	Wire, Yellow Jumper (Water Valve)	8220-119-002	1
*	Wiring Assembly, Relay Board to VFD (Yel. 50")	8220-064-060	2
*	Data Communication Cable (54")	9806-026-002	1

Cabinet and Front Panel Group Part # by Model

Key	Description	T-1800	QTY
1	Panel, Side (Left or Right) - stainless	9444-028-001	4
*	Strap Assembly (side panel)	9966-012-002	2
*	Shim (side panel)	9552-050-001	2
*	Nut, Hex 1/4-20 UNC (for strap assembly)	8641-414-006	8
2	Brace, Side Panel under front panel	9046-086-001	1
•	Nut, Hex	8640-414-006	2
*	Screw	9545-008-026	2
5	Panel Assy, Front Complete	99989-669-003	1
*	Band, Edge Protector	9578-092-005	1
6	Bumper Loading Door	9051-055-001	1
*	Nut, 1/4 x 20 for bumper	8640-414-003	1
*	Screw, Hex- To Control Panel	9545-008-026	2
*	Nut, Spring- To Control Panel 10/32	8640-442-001	2
7	Screw, Flat Head- Front to Sides	9545-008-014	4
8	Washer, Finish	8641-585-001	4
*	Nut, Spring-To Front Panel	8640-442-001	2
9	Label-Door Opening (Blue)	8502-757-002	1
9	Label-Door Opening (Black)	8502-757-001	1
10	Label-Risk of Injury (Blue)	8502-759-002	1
10	Label-Risk of Injury (Black)	8502-759-001	1
11	Panel, Control (Mounts Nameplate)	9989-530-001	1
*	Screw, Control Panel to Sides	9545-008-026	4
12	Nameplate Decal, Control	9412-279-001	1
14A	Panel Top Front	9444-029-001	1
14B	Panel Top Rear	9444-030-001	1
15	Lock, Top (w/Key)	8650-012-003	2
*	Key, Top- # 6324	6292-006-007	1
*	Cam, Lock-Top	9095-049-001	1
*	Nut, 9/32 - 28 Hex	8640-426-001	1
*	Washer Flat 5/16	8641-581-008	1
16	Door, Lower Service, Includes Handle	9960-286-005	1
17	Handle (bumper guard)	9244-086-004	1
*	Rivet Blind 3/16" Alum	9491-009-003	4
*	Screw	9545-008-023	4
18	Screw Mtg., Flat Head 10Bx1 3/4	9545-008-014	2
19	Washer, Finish	8641-585-001	2
*	Nut, Spring	8640-442-001	2

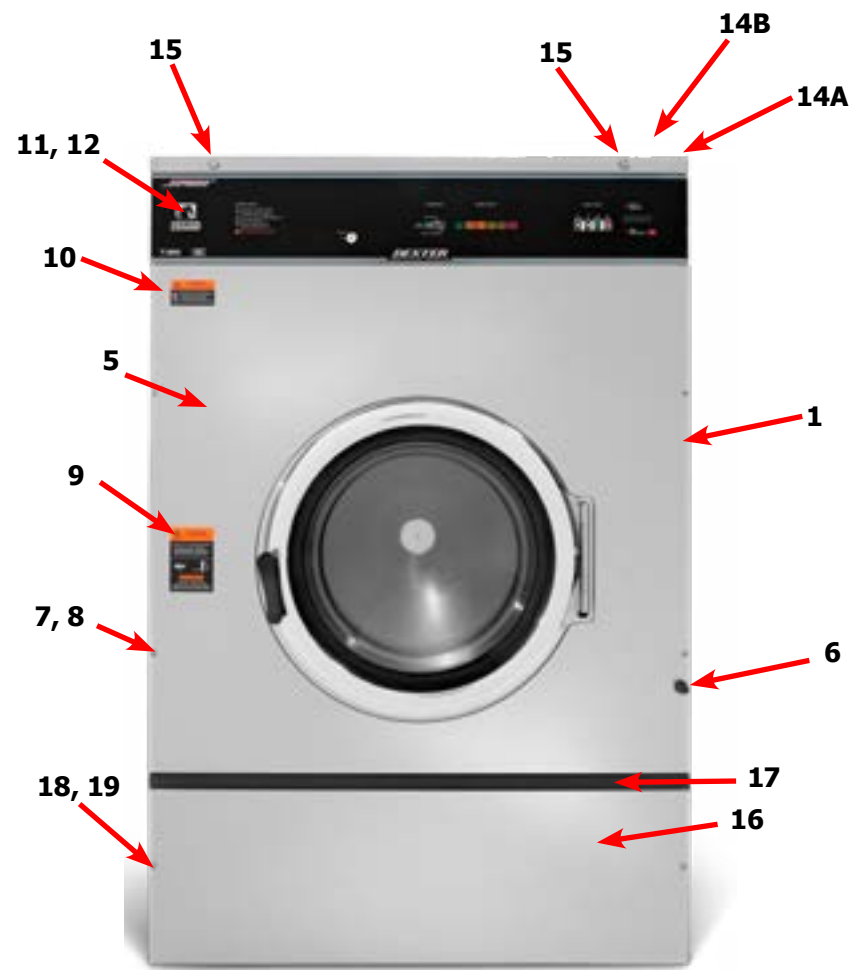
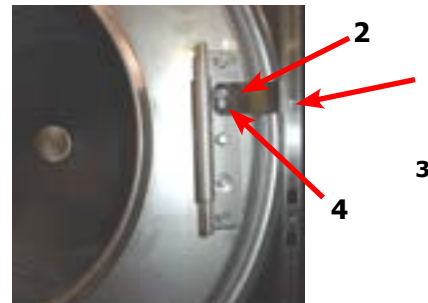

Rear View Access Part # by Model

Key	Description	T-1800	QTY
1	Drive Motor, 3 Phase	9376-328-001	1
2	Rod, Motor Mtg	9497-222-004	1
3	Motor-Bushing, Support	9053-074-002	2
4	Clamp for motor bushing	8654-117-019	2
5	Pulley, Motor	9453-175-002	1
5	Split TaperBushing (motor pulley)	9053-077-001	2
*	Screw taper bushing 1/4-20x1	9545-018-024	3
6	Bolt, Eye (1/4"-20x1/2")	9545-055-001	1
*	Nut, 1/4 Elastic Stop	8640-414-003	1
*	Link (open end)	9341-046-001	1
7	Chain (Spring Tension)	9099-012-004	1
8	Spring, Belt Tension	9534-369-001	1
9	Pulley, Driven	9453-176-006	1
10	Washer-Flat .675x2-1/2x1/4	8641-581-044	1
11	Lockwasher-Exttooth, 5/8	8641-582-020	1
12	Bolt, 3/4-11x1 1/2	9545-057-004	1
13	Bushing Taperlock (Pulley)	9053-078-002	1
14	Bolt, 3/8"-16 x 2"	9545-029-011	3
15	Washer, 3/8"	8641-582-003	3
16	Drive Belt	9040-079-006	1
17	Hose, Overflow to drain	9242-449-005	1
*	Clamp, Hose overflow to drain	8654-117-018	2
18	Hose, Overflow Vent Top	9242-463-006	1
*	Clamp, Hose Vent	8654-117-008	1
*	Vaccum Breaker ALL	9610-001-001	1
*	Clamp, Hose to Vacuum Breaker	8654-117-014	2
19	Hose, Vacuum Breaker to tub	9242-458-003	1
*	Vaccum Breaker Bracket	9029-266-001	1
20	Hose, Pressure Switch	9242-175-003	1
*	Clamp, Pressure Switch Hose	8654-117-015	1
21	Channel, Rear,	9947-055-005	1
22	Screw #10Bx1/2	9545-008-026	4
*	Nut, Spring	8640-442-001	4
23	Cover, Terminal Block	9074-267-001	1
*	Screw #10Bx1/2	9545-008-026	1

50 Lb. Pulley

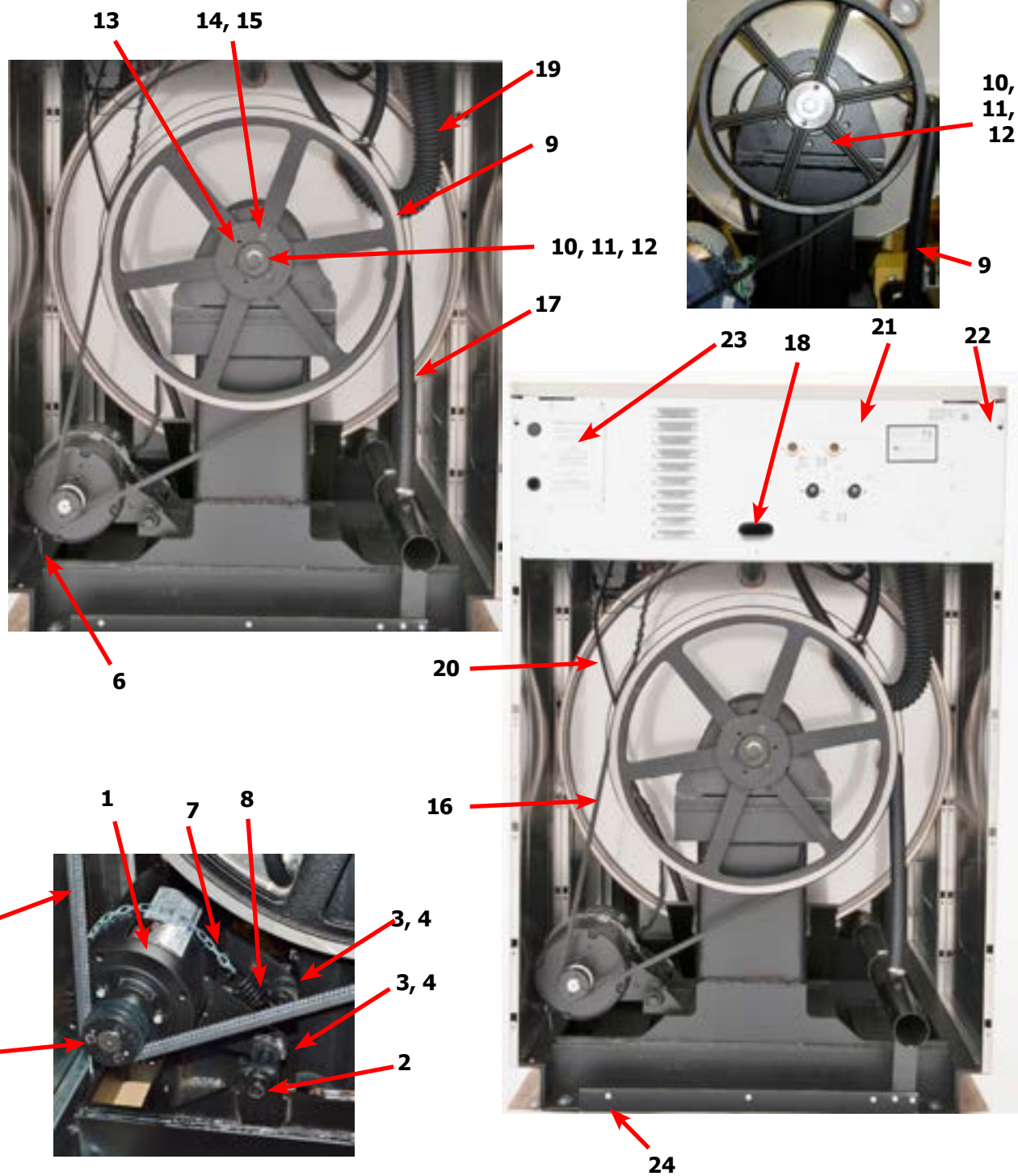

Key	Description	T-1800	QTY
*	Panel Assy., Back, Upper	9454-873-001	1
*	Panel Assy., Back, Lower	9989-872-001	1
*	Screw Panel Mtg.#10Bx1/2"	9545-008-026	13
*	Nut, Spring	8640-442-001	AR
28	Screw, To Base-1/4" x 3/4"	9545-030-002	3

Cylinder, Seals & Bearings Part # by Model

Key	Description	T-1800	QTY
*	Bearings and Seal Kit	9732-219-009	1
*	Housing, Bearing- Assembly (items #2-#6)	9803-209-001	1
2	Housing, Bearing	9241-195-003	1
3	Bearing, Front (Small)	9036-162-002	1
4	Bearing, Rear (Large)	9036-162-001	1
5	Spacer, Bearing	9538-185-001	1
6	Ring, Bearing Retainer	9487-238-004	1
8	Seal, Small V95A	9532-140-012	1
9	Seal, Large V140A	9532-140-008	1
10	Ring, Seal Mounting	9950-062-001	1
11	Tub Back Mating Ring	9487-261-005	1
11G	Mating Ring Guard Shield	9487-276-001	1
12	Bolt, Tub End of Bearing Housing (7/16-14x1), Bolt from inside Tub	9545-059-004	6
13	Washer, Flat	8641-581-034	6
14	Screw-Hex Cap, 7/8"-9 x 3 1/2" (Bearing Housing to Frame)	9545-066-001	6
15	Washers Spherical 7/8" (Male half) (Bearing Housing to Frame)	8641-588-003	6
16	Washers Spherical 7/8" (Female half) (Bearing Housing to Frame)	8641-588-004	6
17	Nut 7/8"-9 (Bearing Housing to Frame)	8640-437-001	6
18	Pulley, Driven	9453-176-006	1
19	Bolt, 3/8"-16 x 2"	9545-029-011	3
20	Washer, 3/8"	8641-582-003	3
21	Bushing Taperlock (Driven & Large)	9053-078-002	1
22	Washer-Flat .675x2-1/2x1/4	8641-581-044	1
23	Lockwasher-Exttooth, 3/4	8641-582-020	1
24	Bolt, 3/4-10x1 1/2	9545-057-004	1
25	Tub & Cylinder Assy	9869-046-001	1
*	Cylinder Assy	9848-170-001	1
*	Tub Front	9974-012-001	1
*	Gasket, Tub Front	9206-421-003	1
*	Ring Assy, Tub Mtg-Front Clamp	9950-061-001	1
*	Bolt, Top Front Ring 3/8"-16 x 3"	9545-029-009	1
*	Nut C Series 3/8"-16	8640-415-001	1

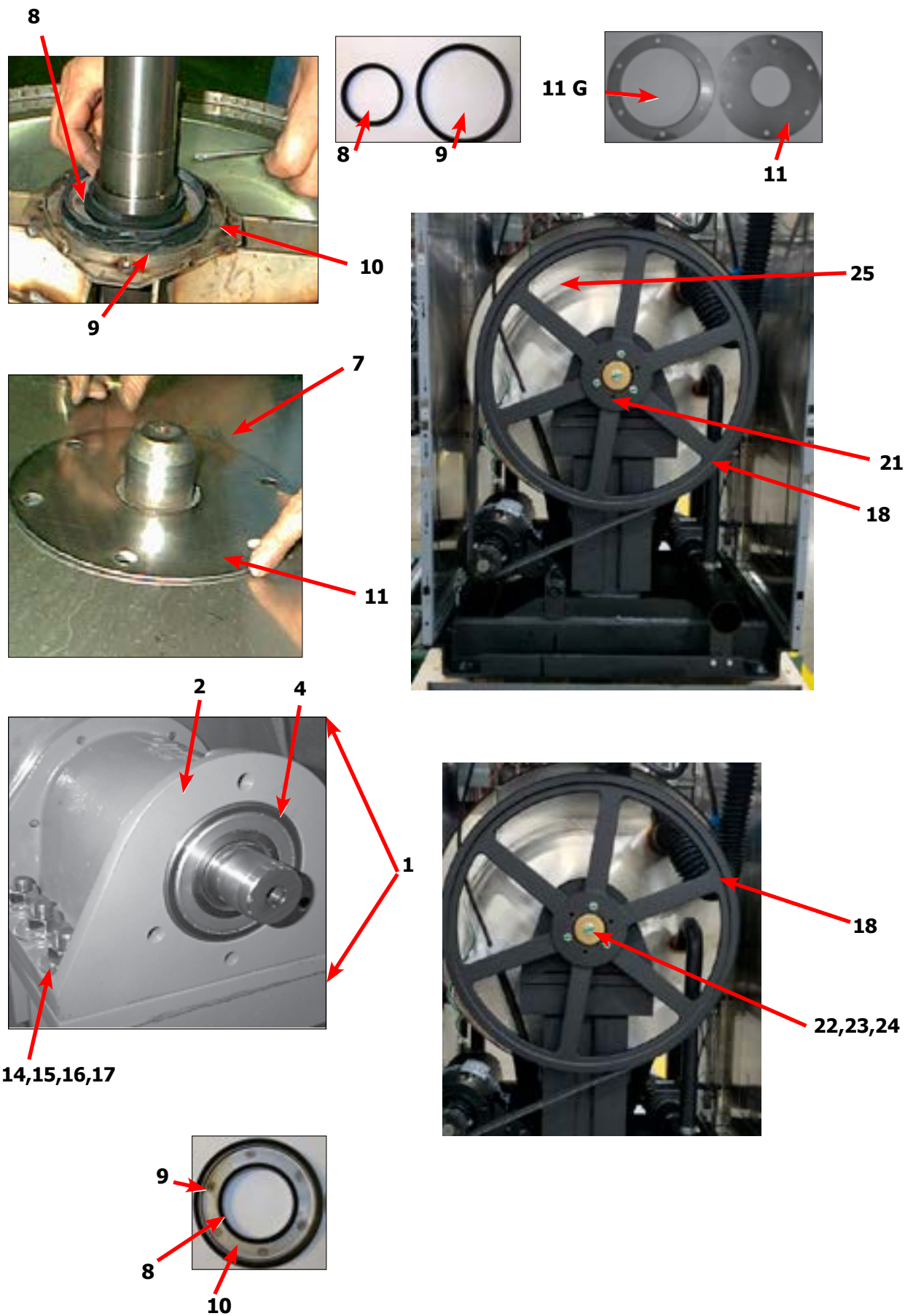

Door Latching Assembly (All Models)

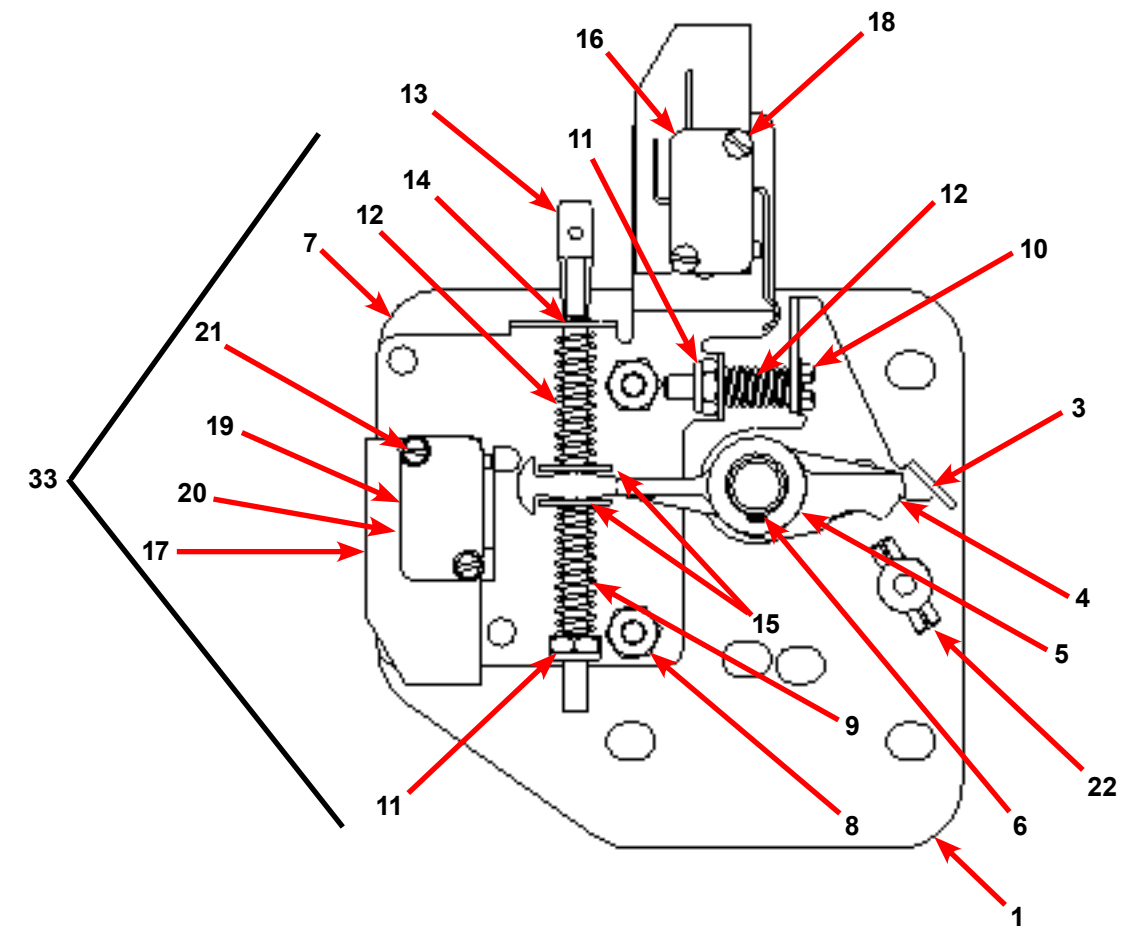

Key	Description	All Models	QTY
33	Latching Assy, Complete (includes #1 thru #22)	9885-031-001	1
1	Plate Assy, Door Lock	9982-346-001	1
2	Washer, Flat (SS or Brass)	8641-581-030	1
3	Actuator, Latching Switch	9008-005-001	1
4	Pawl, Locking	9732-346-002	1
5	Washer, Spring	8641-569-003	1
6	Ring, Retaining	9487-200-004	1
7	Bracket Switch	9029-163-001	1
8	Nut, Hex 10-32 UNF	8640-413-002	2
9	Spring, Actuating	9534-364-002	1
10	Screw, Hx. 10-32 x 1"	9545-012-020	1
11	Nut, Elastic Stop 10-32	8640-413-004	2
12	Spring, Return	9534-364-001	2
13	Pin, Guide	9451-193-001	1

Key	Description	All Models	QTY
14	Ring, Retaining	9487-200-005	1
15	Washer	8641-581-031	1
16	Switch, Latching Sensing	9539-461-008	1
17	Shield, Switch	9550-169-003	3
18	Screw 4-40 x 5/8"	9545-020-001	2
18	Nut, Twin 4-40	8640-401-001	1
19	Switch, Locking Sensing	9539-461-007	2
20	Actuator, Switch Locking	9008-006-003	1
21	Screw 4-40 x 1 1/8"	9545-020-003	2
21	Nut, Twin 4-40	8640-401-001	1
*	Spacer Sensor	9538-182-001	*
22	Pin, Dowel (for door cam)	9451-193-001	1
*	Shim, Door Lock, Thin	9552-037-001	AR
*	Screw, Lock mtg 1/4"-20 x 3/4"	9545-018-014	3
*	Lockwasher 1/4" Ext tooth	8641-582-007	3
*	Door Pin Stud, 3/16" x 3/4"	9451-181-004	1

Gear Motor Door Lock Assembly

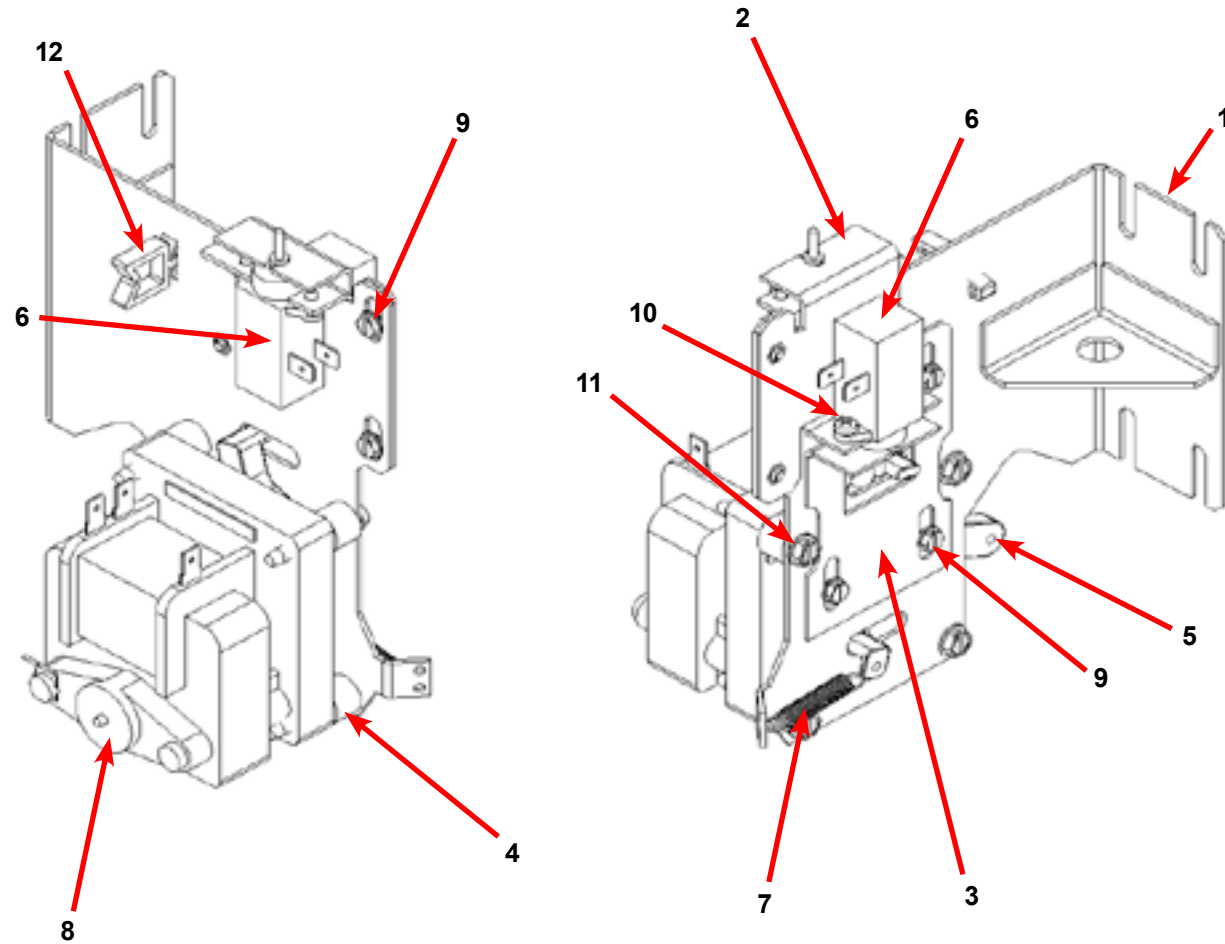

Key	Description	T-1800	QTY
*	Actuator Assembly (Includes 1-10, Rod NOT included)	9892-015-001	1
1	Bracket Assy, Slide Lock Actuator	9985-190-001	1
2	Bracket Assy, Slide - Unlock	9985-189-001	1
3	Bracket Slide Lock	9029-204-001	1
4	Spacer, Plastic	9538-157-021	4
5	Arm - Door Lock	9001-063-001	1
6	Thermoactuator - Door Lock Relay 120v	9586-001-001	2
7	Spring - Extension	9534-350-001	1
8	Motor & Gear Assembly 120v	9914-137-015	1
9	Screw -Hxwshrdslsems, 6-32 x 3/16	9545-044-003	6
10	Cross Recessed PAn Hd Tapping screw	9545-031-011	4
11	Screw hxwshdsl, 10-24 - 1.25f, ctd	9545-046-007	4
12	Standoff-Wire	9527-007-001	1
*	Rod, Door Lock	9497-225-016	1
*	Harness, Door Lock/Drain, P17	9627-791-007	1

Large Door & Hinge Group

Key	Description	T-1800	QTY
1	Door Hinge Assembly (mounts to tub front)	9955-031-001	1
*	Door Assembly Complete	9960-310-001	1
2	Door Ring 180 degree large hnge	9487-275-001	1
3	Door Gasket	9206-431-001	1
4	Door Glass Window	9635-020-001	1
*	Red Wire (Door Close Switch)	8220-063-036	1
*	Black Wire (Door Close Switch)	8220-063-037	1
5	Switch, Door Hinge Close (Plunger)	9539-492-001	1
6	Top Door Hinge Leaf	9845-006-001	1
7	Bottom Door Hinge Leaf	9845-007-001	1
8	Thrd Form Screw, Door Mtg 5/16" x 5/8"	9545-056-002	4
9	Screw, Loading Door Hinge Mtg (5/16" x9/16" ss)	9545-014-009	3
9	Washer, Star 5/16	9913-134-003	3
10	Bracket Retainer support side panel	9046-085-001	1
*	Shim Large door	9552-043-001	1

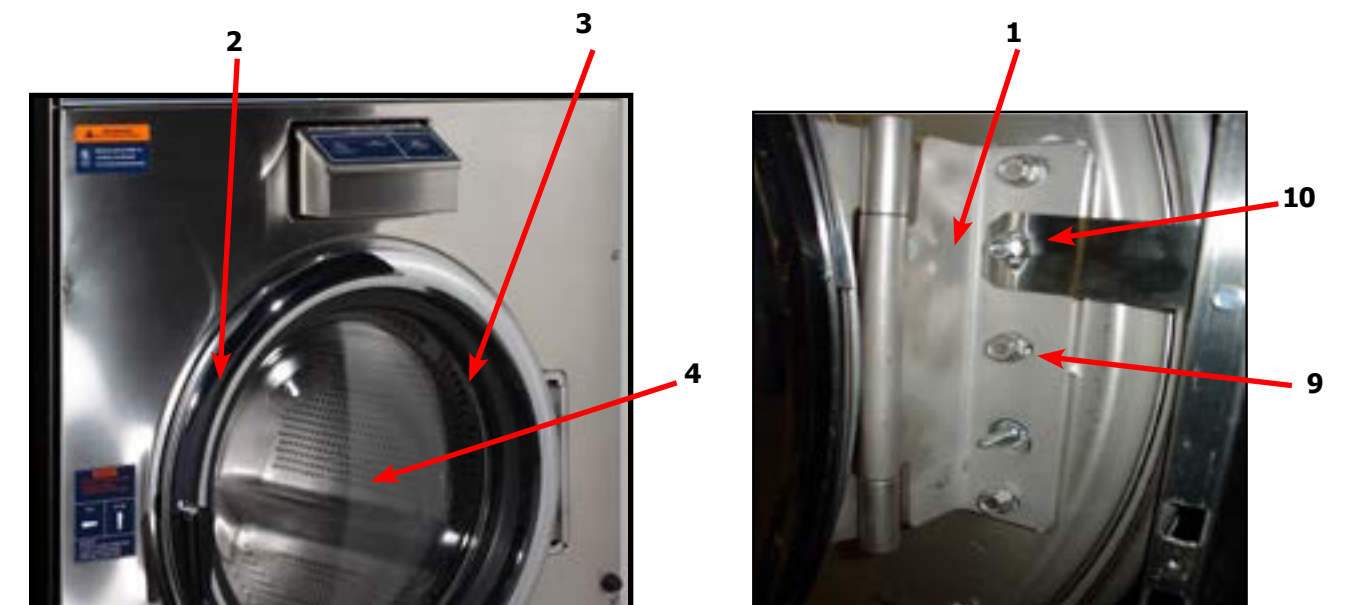

Key	Description	T-1800	QTY
*	Shaft Assembly-Loading Door (11-14)	9913-136-001	1
11	Shaft, Door Locking	9537-195-002	1
12	Cam, Locking	9095-051-001	1
13	Pin, Groove (1 1/4)	9451-181-005	1
14	Pin, Groove (3/4)	9451-181-004	1
15	Spring, Lock Cam	9534-360-002	1
16	Handle, Door	9244-091-001	1
17	Pin, Door Handle (groove)	9451-181-005	1
18	Trim, Edge	9578-092-002	1

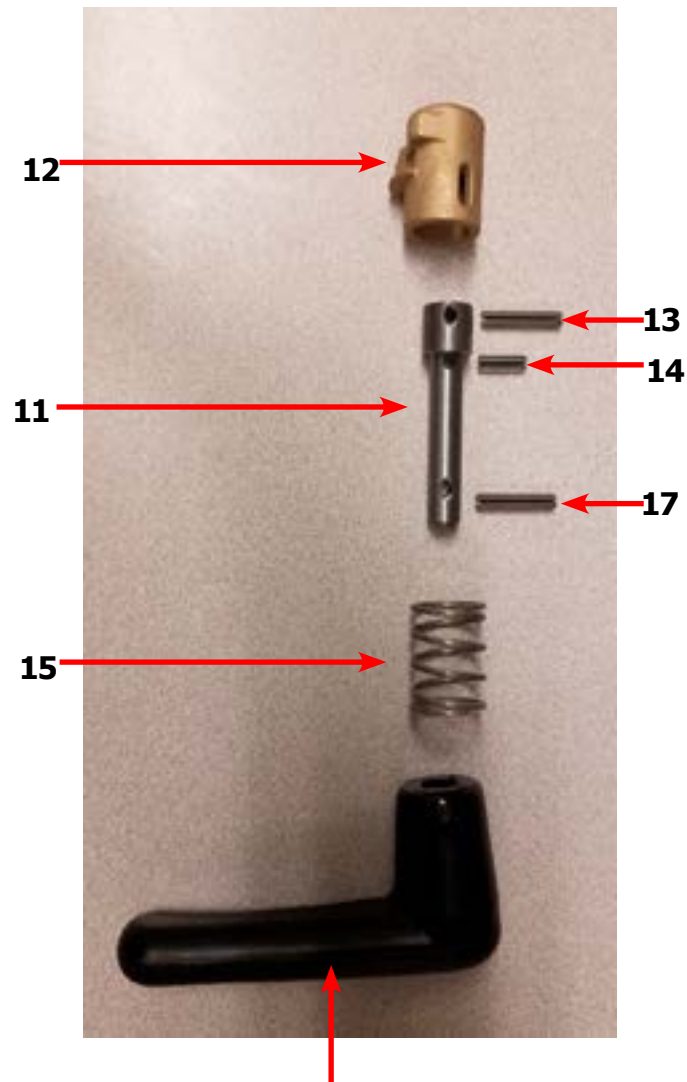

18 1 7

Water Inlet & Rear Channel

Key	Description	T-1800	QTY
1	Channel Assembly, Rear	9497-029-001	1
*	Screw, #10B x 1/2	9545-008-026	4
*	Clip, Spring	8640-442-001	4
2	Mounting Plate Water Valves	9452-814-001	1
3	Nut-Elastic stop, #10-32	8640-413-002	2
4	Valve, Water Inlet (dual outlet) (see Water Inlet Valve Breakdown for individual parts)	9379-183-012	2
5	Screw, Valve Mtg	9545-008-026	4
8	Valve, Water Inlet (Single outlet) (see Water Inlet Valve Breakdown for individual parts)	9379-194-001	2
*	Screw, M4x0 7 x 8mm	9545-064-001	4
*	Wire-Assy, Jumper, Yellow	8220-119-002	1
9	Shield over Water Valves Plastic	9550-195-001	1
10	Push Clip	9083-121-001	3
11	Vacuum Breaker	9610-001-001	1
12	Vacuum Breaker Cap (Red)	0935-135-002	3
*	Bracket, Vacuum Breaker	9029-266-001	1
13	Screw, #10B x 1/2	9545-008-026	4
*	Clamp, Hose to Vacuum Breaker	8654-117-014	1
*	Hose, Vacuum Breaker to Tub	9242-458-003	1
*	Clamp, Tub End	8654-117-009	1
*	Hose, overflow Suds	9242-463-006	4
*	Clamp, Hose-Spring (overflow to tub back)	8654-117-018	2
14	Plate Assembly, Drive Mounting	9452-858-001	1
15	Nut-#10-32UNF, 2B	8640-413-002	4
16	VFD Delta drive 208-240 volt	9375-039-005	1
*	VFD Cooling Fan	9189-016-001	1
*	Wire assy Brown, 3"	8220-057-035	1
*	Wire assy Red, 3"	8220-057-036	1
*	Key Pad-Display Delta Drive	9150-058-001	1
*	Cable-Data, Communication (54")	9806-026-002	1
17	Bushing, 7/8	9053-067-002	1
18	Plug, 7/8	9545-041-006	1
19	Bracket, Terminal-Mounting	9029-326-001	1
20	Screw, #10B x 1/2	9545-008-026	4
21	Label-Warning	8502-639-001	1
22	Strip-Terminal Marker	9558-025-001	1
23	Terminal Block	9897-043-008	1
24	Screw-Phillips, 6ABx3/4	9545-031-010	2
25	Harness-Power, Terminal Block	9627-747-005	1
26	Bushing, 1"	9053-067-004	1
27	Terminal Lug, Solderless	8652-134-001	1
28	Lock-Washer Exttooth #10	8641-582-006	1
29	Screw, #10-32 TTX 1/2 GRN	9545-008-027	1
*	Terminal Block Assembly, Injector, 7pos	9897-032-002	1
*	Terminal Strip, inject, 120v	9558-028-001	1
*	Screw, 4bx5/8	9545-053-002	2

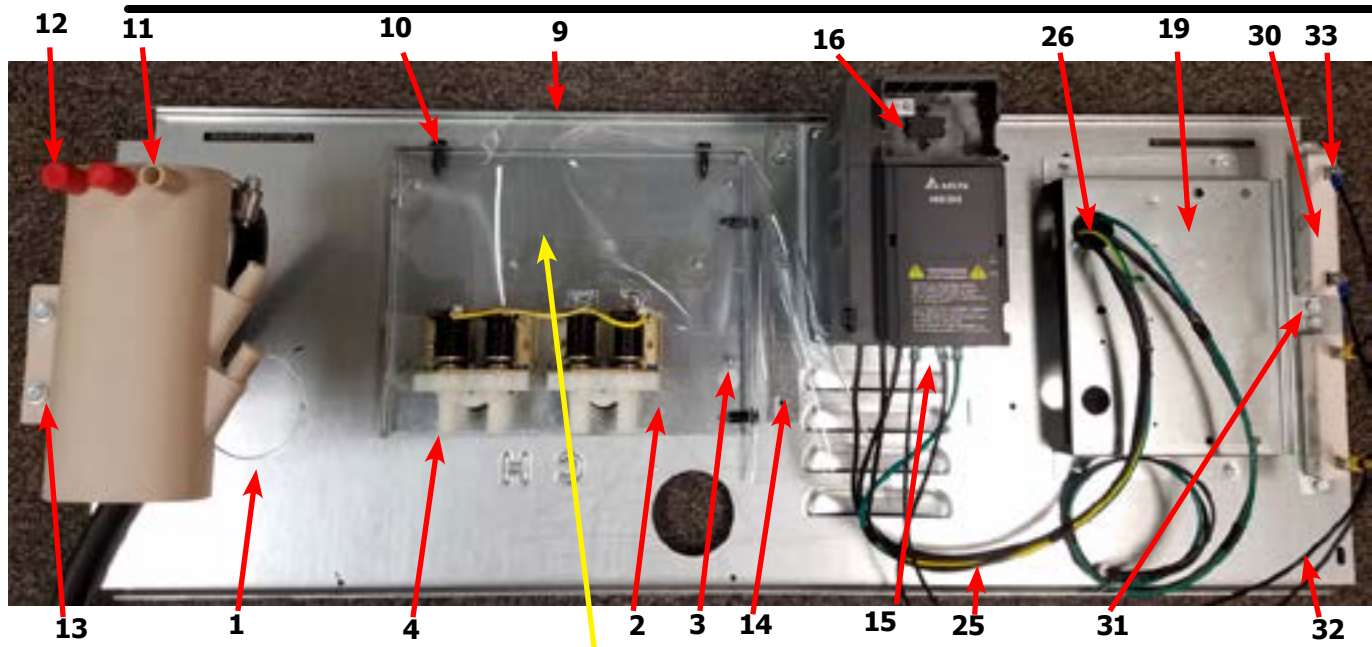

T-1200 Single coil water valve

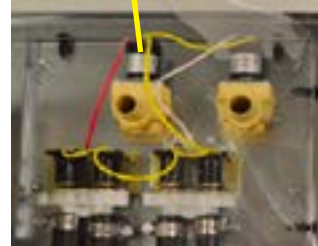

8

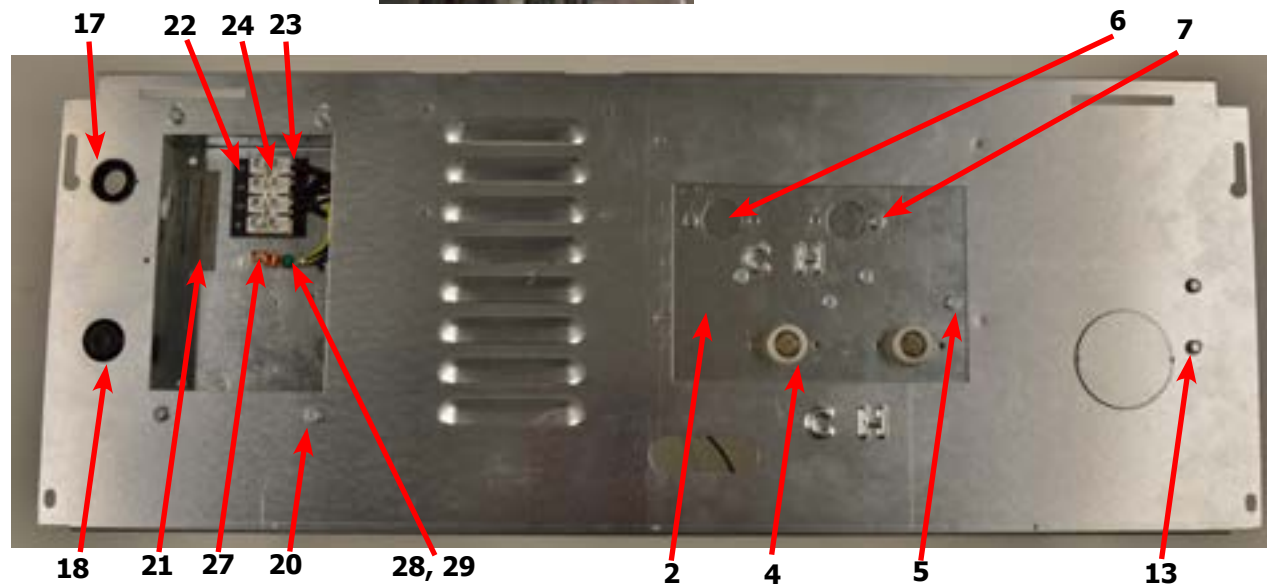

Key	Description	T-1800	QTY
30	Braking resistors (160 ohm)	9483-004-003	2
31	Screw-#10Bx1/2	9545-008-026	4
32	Wire Assy, Jumper	8220-117-003	2
33	Screw, #6-32x5/16	9545-044-006	4
33	Nut, #6-32	8640-411-003	4
*	Cover Controls	9074-267-001	1
*	Screw-#10Bx1/2	9545-008-026	1
*	Label-Warning, Notice	8502-761-001	1

Water Inlet Valve Breakdown Part # by Model

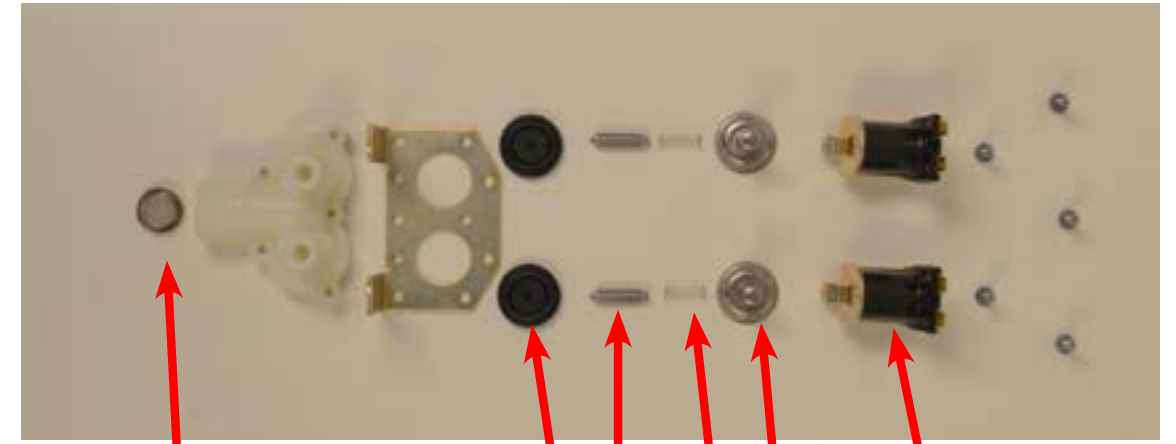

Key	Description	T-1800	QTY
*	Valve, Water Inlet (includes 1 thru 6) - Invensys	9379-183-012	2
1	Screen, Inlet end of valve	9555-056-001	2
2	Coil Assy., 120 V Invensys	9089-017-001	2
3	Diaphragm Invensys (EPDM)	9118-049-001	2
3	Diaphragm Invensys (Viton)	9118-049-002	2
3	Diaphragm Invensys (EPDM NSF)	9118-049-003	2
4	Guide, Solenoid Invensys	9211-021-002	2
5	Armature Invensys	9015-008-001	2
6	Spring, Armature Invensys	9534-298-001	2
*	Wiring Harness	9627-795-005	1

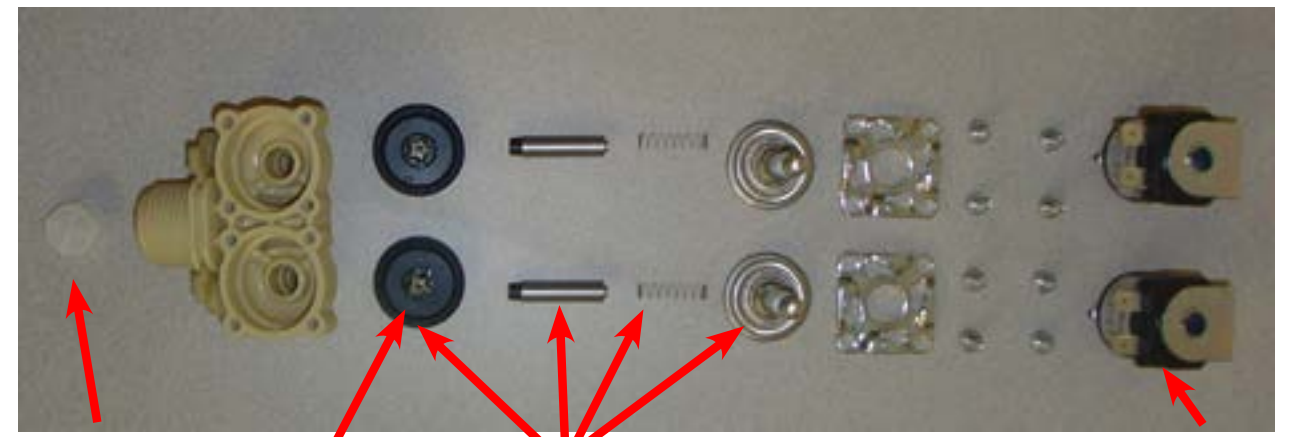

Optional Water Valve

Key	Description	T-1800	QTY
*	Dual Coil Water Valve Mueller	9379-192-001	1
7	Valve Water Body Complete(no coil)	9379-192-002	1
8	Diaphragm Mueller	9118-054-001	2
9	Filter Mueller	9183-046-001	2
10	Coil Mueller	9089-051-001	2
11	Diaphragm Assembly Mueller Includes	9785-001-001	2

Drain Valve Group Part # by Model

Key	Description	Part Number	Qty
1	Valve, Drain (includes #2 thru #11)	9379-202-001	1
2	Body, Valve (w/ball)	9064-072-001	1
3	Motor & Gear Train (complete)	9914-137-023	1
4	Plate, Motor Mtg	9452-538-001	1
5	Screw	8639-994-001	1
6	Spring, Drive	9534-339-001	1
7	Screw	9545-054-001	1
8	Screw	9545-054-002	1
9	Seal, V Packer	9532-134-001	1
10	Washer	8641-584-001	1
11	Pin, Main Drive	9451-196-001	1
*	Plate (spacers needed for replacement motor mtg. plate)	9538-149-001	1
12	Kit - Seal Replacement	9732-327-001	1

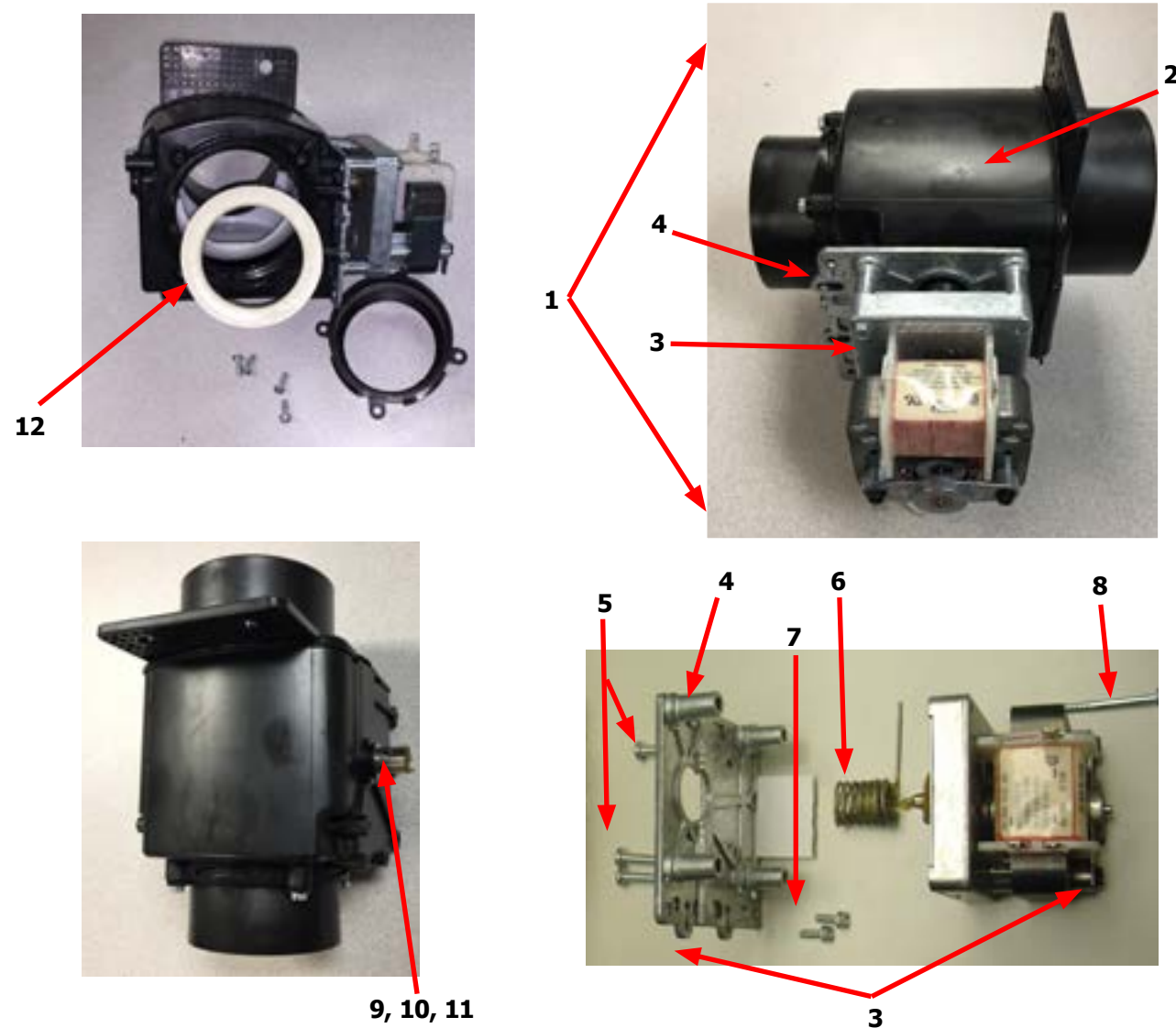

Chassis and Drain Part # by Model

Key	Description	T-1800	QTY
1	Base Assy,Frame	9945-158-002	1
2	Outer Tub Assy	9930-187-001	1
*	Tub & Cylinder Assy	9869-046-001	1
3	Tub Front	9974-012-001	1
*	Gasket, Tub Front	9206-421-003	1
4	Ring Assy, Tub Mtg-Front Clamp	9950-061-001	1
5	Bolt, Top Front Ring 3/8"-16 x 3"	9545-029-009	1
6	Nut C Series 3/8"-16	8640-415-001	1
7	Bolt, 1/2" -13 x 2" (Tub Mounting to Frame)	9545-017-013	2
8	Nut, Wizloc 1/2" x 13	8640-417-005	2
9	Washer, Flat 1/2"	8641-581-026	2
10	Hose, Tub to Drain Valve	9242-456-001	1
11	Clamp, Hose (Tub to Drain Valve)	8654-117-014	2
12	Valve, Drain	9379-202-001	1
*	Screw, Valve to Base 1/4ABx3/4	9545-030-002	2
*	Washer, Flat 1/4	8641-581-018	4
13	Hose, Drain Valve to Tube	9242-457-002	1
*	Clamp, Hose (Drain Valve to Tube)	8654-117-014	2
14	Tube Assy, Drain	9915-129-002	1
15	Clamp, Hose (Tube to Frame Bracket)	8654-117-014	1
*	Bracket, Drain Tube	9029-067-004	1
*	Screw Tube (Bracket to Base 1/4Bx3/4)	9545-030-002	4
16	Hose, Overflow Tub To Drain Tube	9942-449-005	1
*	Clamp, Hose	8654-117-018	1
*	Tube, Suds overflow	9242-463-006	1
*	Clamp, Hose	8654-117-008	2
17	Hose, Pressure switch	9242-175-003	1
	Clamp, Overflow Hose	8654-117-015	1

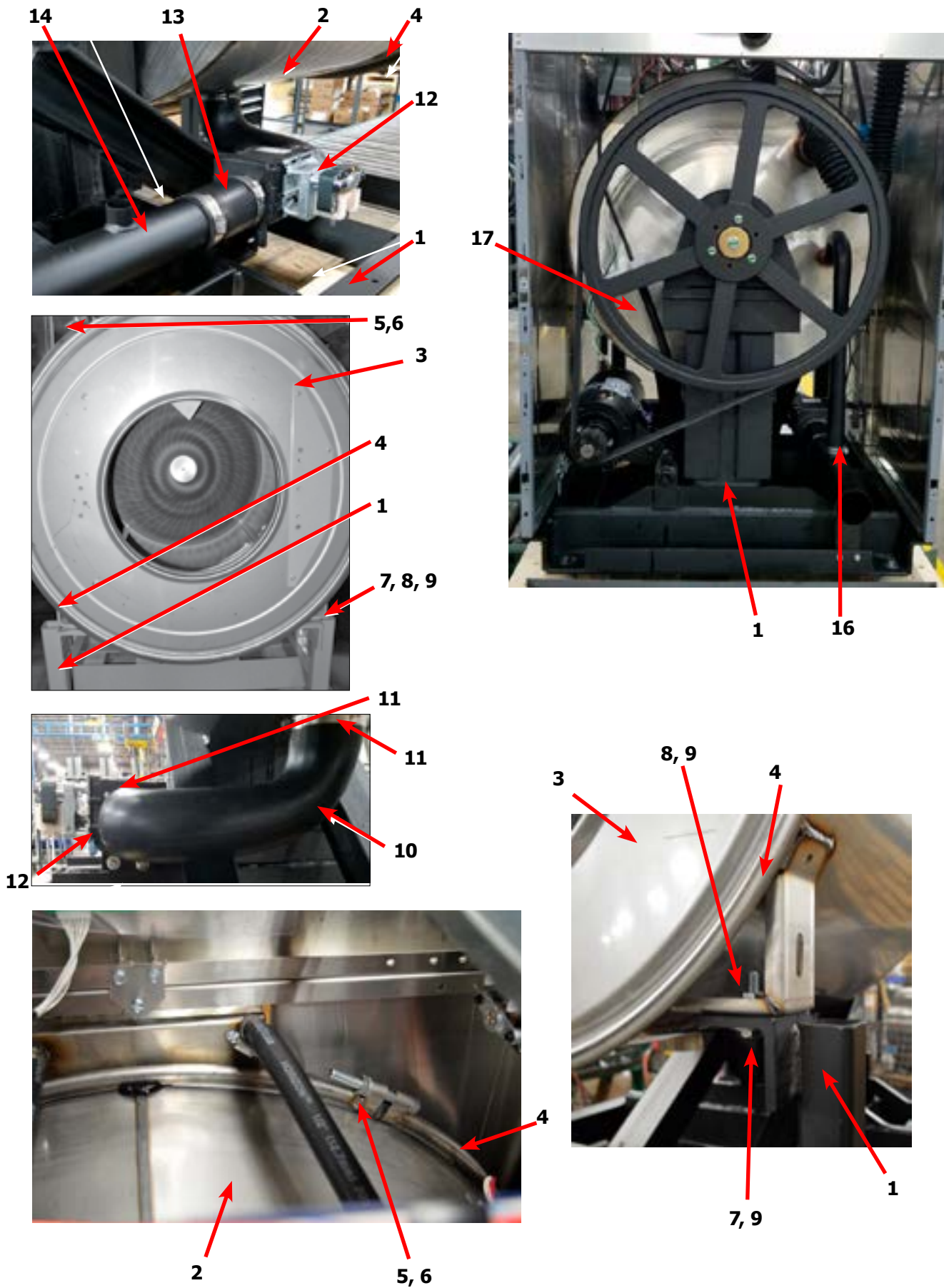

Key	Description	T-1800	QTY
1	Trough Assy,Controls 208-240 volt (all parts below #2-#43 & trough)	9857-300-001	1
*	Trough only	9839-017-001	1
*	Screw, Trough Sides	9545-008-026	4
*	Lockwasher #10	8641-582-006	4
2	Spreader-Chanel, Trough	9081-136-001	
*	Screw, Mtg #10Bx1/2"	9545-008-026	4
3	Transformer, Control (Secondary Voltage to 115 volts)	8711-004-001	1
*	Screw, Mtg #10Bx1/2"	9545-008-026	4
*	Lockwasher #10	8641-582-006	4
4	Screw GRN. #10-32x 1/2"	9545-008-027	1
5	Lockwasher #10	8641-582-006	1
6	Lug, Grounding	8652-130-037	1
7	PCB assembly Relay Main	9473-006-001	1
*	Support, Edge Holding	9548-285-001	6
*	Harness, P17 Drain/Therm/Sol	9627-796-002	1
*	Harness P19/Water Valve	9627-795-005	1
*	Harness P8/P16	9627-794-001	1
*	Harness P20/P21	9627-793-001	1
*	Harness, P19/Water Valve	9627-795-005	1
*	Bushing , Wire 7/8	9053-067-002	2
*	Standoff Twistlock	9527-002-002	3
8	Terminal Block Assy, POWER	9897-026-004	1
*	Screw, Mtg 8ABx1/2"	9545-045-012	2
*	Kit-Pressure Sensor, Electronic	9732-314-001	1
9	Kit-Replacement, Pressure Sensor (only)	9732-315-001	1
*	Support-PCB, 3/8", Edge Holding	9548-285-001	4
*	Screw, Mtg #8Bx1/4"	9545-045-001	2
*	Harness P5/Pressure	9627-958-001	1
10	Transformer	8711-009-001	1
*	Screw, Transformer Mtg #8Bx1/4"	9545-045-001	4
*	Lockwasher #6 exttooth	8641-582-005	4
11	Fuseholder	9200-001-002	1
*	Fuse 2.5 amp	8636-018-004	1
12	Label Fuse 2.5 amp Rear	8502-716-002	1
*	Transformer, 120/18vac, 5va	8711-015-001	1
13	Angle Support Trough	9029-318-001	1
*	Screw, Trough Bracket	9545-008-026	4
14	Chanel-Support, Trough	9081-173-001	1
*	Screw, Mtg #10Bx1/2"	9545-008-026	4
15	Chanel	9081-108-002	1
*	Screw, Mtg #10Bx1/2"	9545-008-026	2
*	Wire Assy BLK/BLU	8220-001-231	1
*	Wire Assy RED/BLU	8220-001-230	1

Electrical Components - Top Compartment

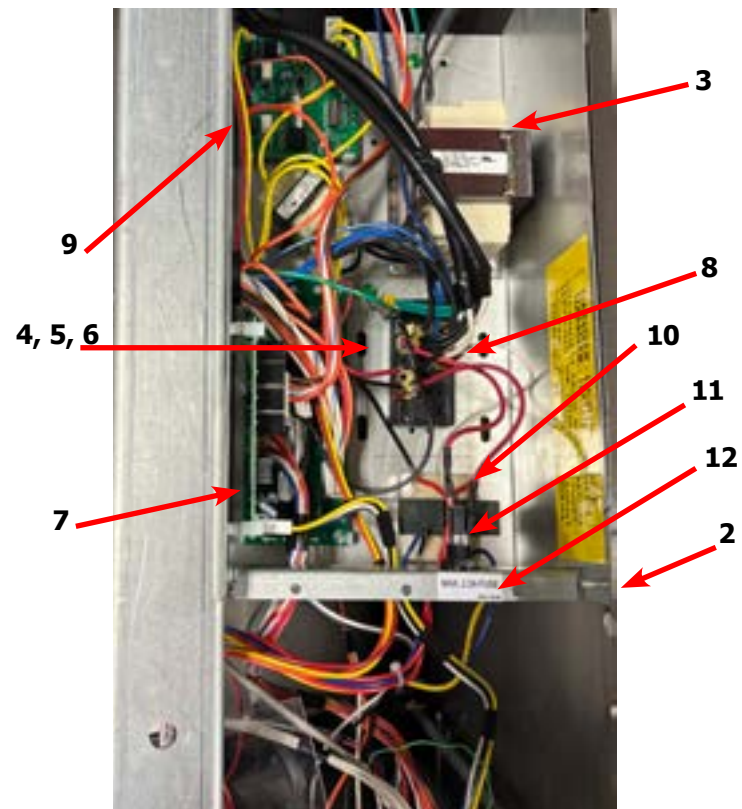
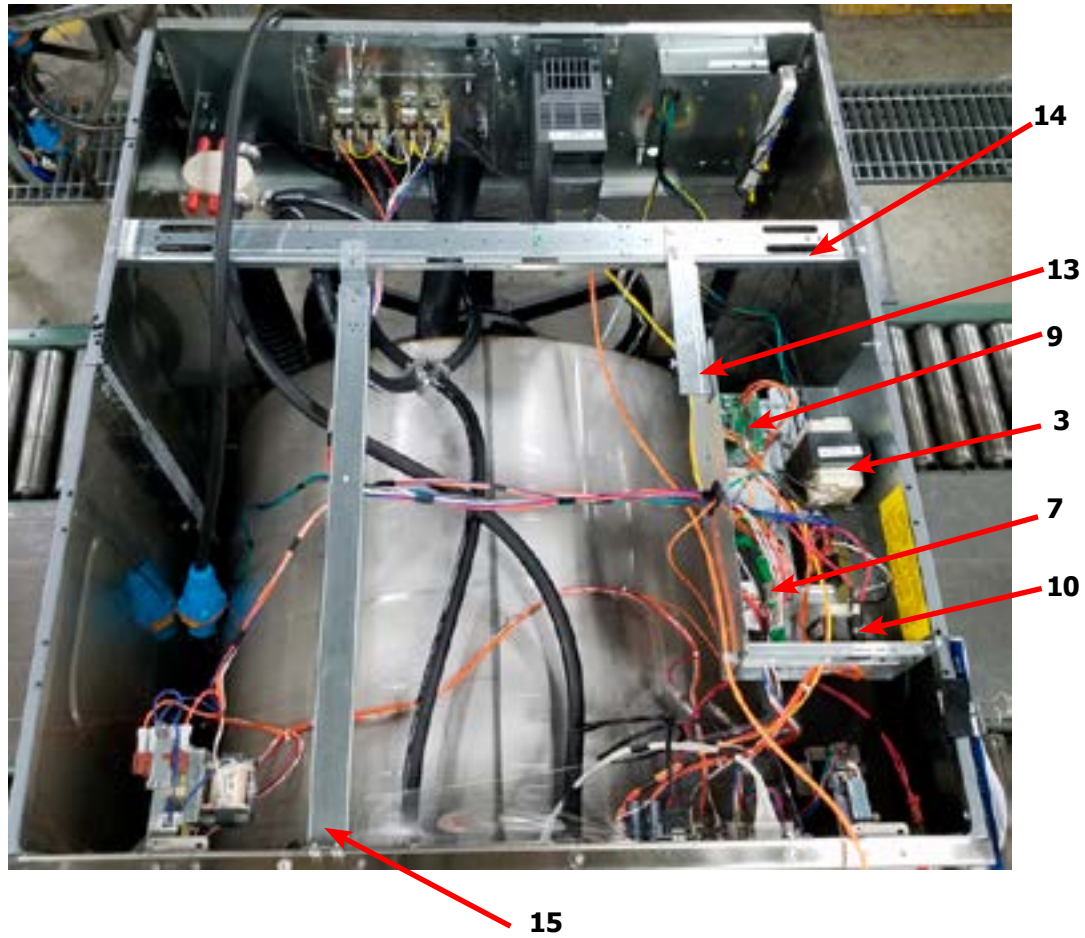

Control Panel Part # by Model

Key	Description	T-1800	QTY
1	Panel Control Assembly(panel only)	9989-530-001	1
2	Nameplate,Control Panel (one piece) Black	9412-279-001	1
*	Screw-Hxwshrhnduct #10Bx 1/2"(Control Panel To side Panel)	9545-008-026	4
3	Plastic Shield over main PCB	9550-184-001	1
4	Nut Hexkeys #8-32	8640-412-005	3
5	Screw FillHDCR 10Bx1/2" Guide	9545-008-023	1
6	Locator Panel	9355-001-001	1
7	Plate -Latch, Top	9452-625-001	2
8	Nut Hexkeys #8-32	8640-412-005	4
9	Spacer Pushbutton (Micro)	9538-192-001	1
10	Pushbutton Control (OPL), Black	9035-062-003	1
11	Retainer Pushbutton (Micro)	9486-158-001	1
12	Nut Hexelasticstop #4-40	8640-424-002	2
13	Spacer Plastic #6x9/16	9538-157-018	5
14	PCB assembly Control /Display	9473-004-010	1
15	Nut Elasticstop #6-32	8640-411-002	4
16	Nut Hexkeys #6-32	8640-411-003	1
17	Spacer Plastic #6x9/16	9538-157-018	2
18	PCB assembly Mode lights	9473-005-001	1
19	Nut Hexkeys #6-32	8640-411-003	2
20	Harness-LED PCB, P3	9627-797-001	1
21	Spacer Plastic #6x9/16	9538-157-018	2
22	Light, LED,ADD BLEACH Asembly	9794-001-001	1
23	Nut Hexkeys #6-32	8640-411-003	2
24	Lock-Run/Program, w/Harness & Key, P2	8650-027-001	1
*	Key (N561)	6292-006-013	AR
25	Actuator Assy-Door Locking, 120V	9892-015-001	1
26	Nut Hexkeys #8-32	8640-412-005	4
27	Nut-Spring	8640-399-008	2
28	Bracket-Retainer, Front Panel	9029-191-001	1
29	Screw FillHDCR 10Bx1/2" Guide	9545-008-023	2
*	Harness-PCB to Relay, P8-P16	9627-794-001	1
*	Harness-Door Lock, P4	9627-791-007	1
*	Harness-PCB to Enable, P20-P21	9627-793-001	1
*	Transformer-120V/24/5.3, P7	8711-009-001	1

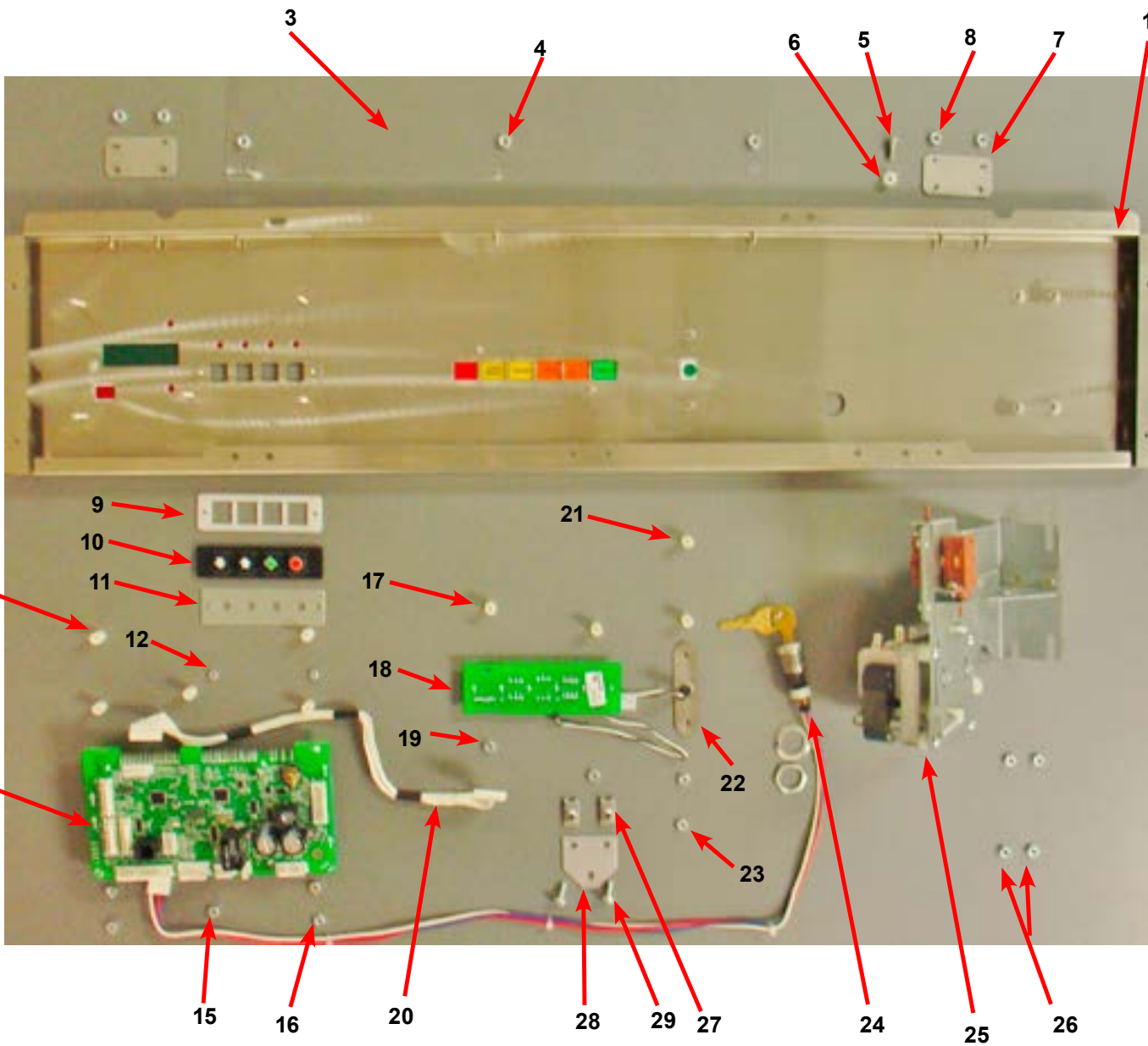

Labels and Diagrams

Key	Description	T-1800	QTY
*	Wiring Diagram and Schematic, Coin	9506-871-001	1
*	Transient Voltage Surge Suppressor Infomational	8507-330-001	1
*	Label High Voltage Warning	8502-614-004	1
*	Label Fusing & Installation	8502-619-003	1
*	Label Quality	8511-001-002	1
1	Label Warning Door Opening (Blue)	8502-757-002	1
1	Label Warning Door Opening (Black)	8502-757-001	1
2	Label Warning Risk of Injury (Blue)	8502-759-002	1
2	Label Warning Risk of Injury (Black)	8502-759-001	1
3	Label Dispenser (Blue)	8502-756-002	1
3	Label Dispenser (Black)	8502-756-001	1
*	Booklet Owners	8514-296-001	1

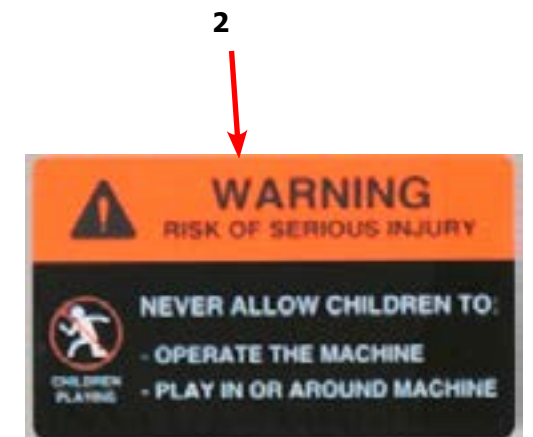

Section 11:

Maintenance

Preventative Maintenance

Daily

- Step 1:** Check that the loading door remains securely locked and cannot be opened during an entire cycle.
- Step 2:** Clean the top, front, and sides of the cabinet to remove residue.
- Step 3:** Clean the soap dispenser and lid and check that all dispenser mounting screws are in-place and tight.
- Step 4:** Check the loading door for leaks. Clean the door seal of all foreign matter.
- Step 5:** Leave the loading door open to aerate the washer when not in use.

Quarterly

- Step 1:** Make sure the washer is inoperative by switching off the main power supply.
- Step 2:** Check the V-belts for wear and proper tension.
- Step 3:** Clean lint and other foreign matter from around motor.
- Step 4:** Check all water connections for leaks.
- Step 5:** Check the drain valve for leaking and that it opens properly.
- Step 6:** Wipe and clean the inside of the washer and check that all electrical components are free of moisture and dust.
- Step 7:** Remove and clean water inlet hose filters. Replace if necessary.
- Step 8:** Check anchor bolts. Retighten if necessary.