

**INDUSTRIAL WASHERS**  
**MODELS T-300/350/400/450/600/650/750/900/950/1200/1450/1800**  
**ON-PREMISE V-SERIES 6 CYCLE CONTROL**



**DEXTER.**  
**LAUNDRY**

**OPERATOR'S MANUAL**  
**INSTALLATION & OPERATION**  
**INSTRUCTIONS**

Please read this information and retain for reference.

**WARNING** - THIS WASHER IS EQUIPPED WITH DEVICES AND FEATURES RELATING TO ITS SAFE OPERATION. TO AVOID INJURY OR ELECTRICAL SHOCK, DO NOT PERFORM ANY SERVICING UNLESS QUALIFIED TO DO SO.

IT IS THE RESPONSIBILITY OF THE OWNER TO CHECK THIS EQUIPMENT ON A FREQUENT BASIS TO ASSURE ITS SAFE OPERATION.

A machine should NOT be allowed to operate if any of the following occur:

- Excessively high water level.
- If machine is not connected to a properly grounded circuit.
- If the door does not remain securely locked during the entire cycle.
- Vibration or shaking from an inadequate mounting or foundation.

**WARNING - SAFETY PRECAUTIONS**

- Always shut off power and water supply before servicing.
- Do not overload the washer.
- Do not open door when cylinder is in motion or it contains water.
- Do not bypass any safety devices of this washer.
- Do not use volatile or flammable substances in or near this washer.
- Keep all panels in place. They protect against shock and injury and add rigidity to the washer.

**PREVENTIVE MAINTENANCE REQUIREMENTS**

**DAILY**

- Check that the loading door remains securely locked and cannot be opened during an entire cycle.
- Clean the top, front, and sides of the cabinet to remove residue.
- Clean the soap dispenser and lid and check that all dispenser mounting screws are in-place and tight.
- Check the loading door for leaks. Clean the door seal of all foreign matter.
- Leave the loading door open to aerate the washer when not in use.

**QUARTERLY**

- Make sure the washer is inoperative by switching off the main power supply.
- Check the V-belts for wear and proper tension.
- Clean lint and other foreign matter from around motor.
- Check all water connections for leaks.
- Check the drain valve for leaking and that it opens properly.
- Wipe and clean the inside of the washer and check that all electrical components are free of moisture and dust.
- Remove and clean water inlet hose filters. Replace if necessary.
- Check anchor bolts. Retighten if necessary.

**IMPORTANT:** Replace any and all panels that were removed to perform daily and/or quarterly maintenance.

## TABLE OF CONTENTS

1	WASHER SPECIFICATION SHEET.....	4
1.1	Standard Washers .....	4
1.2	Express Washers .....	5
2	INSTALLATION INSTRUCTIONS .....	6
2.1	FOUNDATION REQUIREMENTS.....	6
2.2	MOUNTING HEIGHT .....	6
2.3	FOUNDATION AND PAD OPTIONS.....	7
2.3.1	WASHER INSTALLATION ON EXISTING FLOOR: .....	8
2.3.2	WASHER INSTALLATION ON NEW FLOOR: .....	8
2.3.3	NEW PAD TIED TO EXISTING FLOOR: .....	8
2.3.4	STEEL MOUNTING BASE ON CONCRETE FLOOR:.....	10
2.4	MACHINE ANCHORING.....	10
2.5	MACHINE GROUTING.....	11
2.6	FLOOR LOAD DATA.....	12
2.7	MOUNTING DETAILS .....	13
2.7.1	T-300 Machine Mounting Detail.....	13
2.7.2	T-300 Machine Side By Side Mounting Detail.....	14
2.7.3	T-300 Industrial Washer Dimensions .....	15
2.7.4	T-350 Machine Mounting Detail.....	16
2.7.5	T-350 Machine Side By Side Mounting Detail.....	17
2.7.6	T-350 Industrial Washer Dimensions .....	18
2.7.7	T-400 Machine Mounting Detail.....	19
2.7.8	T-400 Machine Side By Side Mounting Detail.....	20
2.7.9	T-400 Industrial Washer Dimensions .....	21
2.7.10	T-450 Machine Mounting Detail.....	22
2.7.11	T-450 Machine Mounting Detail.....	23
2.7.12	T-450 Industrial Washer Dimensions .....	24
2.7.13	T-600 Machine Mounting Detail.....	25
2.7.14	T-600 Machine Mounting Detail.....	26
2.7.15	T-600 Industrial Washer Dimensions .....	27
2.7.16	T-650 Machine Mounting Detail.....	28
2.7.17	T-650 Machine Side By Side Mounting Detail.....	29
2.7.18	T-650 Industrial Washer Dimensions .....	30
2.7.19	T-750 Machine Mounting Detail.....	31
2.7.20	T-750 Machine Side By Side Mounting Detail.....	32
2.7.21	T-750 Industrial Washer Dimensions .....	33

2.7.22	T-900/950 Machine Mounting Detail .....	34
2.7.23	T-900/950 Machine Side By Side Mounting Detail .....	35
2.7.24	T-900/950 Industrial Washer Dimensions.....	36
2.7.25	T-1200 Machine Mounting Detail.....	37
2.7.26	T-1200 Machine Side By Side Mounting Detail .....	38
2.7.27	T-1200 Industrial Washer Dimensions .....	39
2.7.28	T-1450 Machine Side By Side Mounting Detail .....	41
2.7.29	T-1450 Industrial Washer Dimensions .....	42
2.7.30	T-1800 Machine Mounting Detail.....	43
2.7.31	T-1800 Machine Side By Side Mounting Detail .....	44
2.7.32	T-1800 Commercial Washer Dimensions .....	45
2.8	PLUMBING .....	46
2.9	DRAIN .....	46
2.10	PROTECTIVE FILM.....	46
2.11	ELECTRICAL.....	46
2.11.1	INSTALLING THE ELECTRICAL CONNECTION.....	48
2.11.2	FUSING REQUIREMENTS.....	48
2.11.3	CONTROLS TRANSFORMER (208-240V 60 Hz models only) .....	49
2.11.4	CONTROLS TRANSFORMER (230V 50 Hz models only).....	49
2.11.5	MAXIMUM SPIN SPEED ADJUSTMENT (All washers except T-950).....	50
2.11.6	MAXIMUM SPIN SPEED ADJUSTMENT (T-950 Only).....	51
2.12	OPERATION CHECK .....	53
3	OPERATING INSTRUCTIONS .....	54
3.1	STARTING THE WASHER.....	54
3.2	END OF CYCLE .....	55
3.3	SAFETY DOOR LOCK.....	55
3.4	VARIABLE FREQUENCY DRIVE INDICATORS .....	55
4	MACHINE PROGRAMMING INSTRUCTIONS.....	56
4.1	EDITING AN EXISTING CYCLE .....	56
4.2	DEFAULT WASHER CYCLE PROGRAMS .....	58
4.3	RAPID ADVANCE MODE.....	62
4.4	WATER LEVEL ADJUSTMENT .....	63
5	DISPLAYED WASHER MESSAGES .....	64
6	TROUBLESHOOTING .....	66
7	TRANSIENT VOLTAGE SURGE SUPPRESSORS.....	69
8	SERVICE AND PARTS.....	70

# 1 WASHER SPECIFICATION SHEET

## 1.1 Standard Washers

		T-300		T-400		T-600		T-900		T-1200		T-1800	
Capacity	Dry Weight Capacity - lb (kg)	20	(9.1)	30	(13.6)	40	(18.1)	60	(27.2)	80	(36.3)	120	(54.4)
	Cylinder Volume - cu ft (L)	2.7	(76.5)	4	(113.3)	6	(170)	9	(254.9)	11.5	(325.6)	17.4	(492.7)
Speed	High Extract Speed - g (RPM)	100	(579)	100	(532)	100	(532)	100	(485)	100	(485)	140	(516)
	Intermediate Extract Speed - g (RPM)	60	(449)	60	(412)	60	(412)	60	(375)	60	(375)	60	(338)
	Washing Speed - g (RPM)	0.8	(52)	0.9	(50)	0.9	(50)	0.9	(43)	0.9	(43)	0.9	(39)
	Motor Size - hp (kW)	1	(0.75)	2	(1.5)	2	(1.5)	3	(2.2)	3	(2.2)	7.8	(5.8)
Dimensions	Cabinet Height - in (cm)	43 7/8	(111.4)	48 3/16	(122.4)	49 11/16	(126.2)	55 3/8	(140.7)	57 7/8	(147)	62 3/8	(158.4)
	Cabinet Width - in (cm)	26	(66)	29 7/8	(75.9)	29 7/8	(75.9)	34 3/8	(87.3)	34 3/8	(87.3)	41 1/2	(105.4)
	Cabinet Depth - in (cm)	25	(63.5)	27 3/8	(69.5)	36	(91.4)	38 7/8	(98.8)	45 3/8	(115.3)	48 1/4	(122.6)
	Door Opening - in (cm)	12 1/4	(31.1)	15 1/4	(38.7)	15 1/4	(38.7)	19 1/4	(48.9)	19 1/4	(48.9)	19 1/4	(48.9)
	Floor to Door Bottom - in (cm)	14 7/8	(37.8)	16 1/4	(41.3)	16 1/4	(41.3)	16	(40.6)	18 1/2	(47)	19 5/16	(49.1)
	Cylinder Diameter - in (cm)	21	(53.3)	25	(63.5)	25	(63.5)	30	(76.2)	30	(76.2)	37	(94)
	Cylinder Depth - in (cm)	13 1/2	(34.3)	14 1/8	(35.9)	21 1/8	(53.7)	22	(55.9)	28	(71.1)	28	(71.1)
Weight	Net Weight - lb (kg)	317	(143.8)	432	(196)	558	(253.1)	964	(437.3)	1022	(463.6)	1415	(641.8)
Shipping	Shipping Weight - lb (kg)	340	(154.2)	450	(204.1)	580	(263.1)	980	(444.5)	1063	(482.2)	1460	(662.2)
	Shipping Height - in (cm)	50	(127)	53 1/4	(135.3)	54 3/4	(139.1)	61 1/2	(156.2)	63 3/4	(161.9)	69 1/4	(175.9)
	Shipping Width - in (cm)	27 1/4	(69.2)	31 1/2	(80)	31 1/2	(80)	36	(91.4)	36	(91.4)	43 1/8	(109.5)
	Shipping Depth - in (cm)	30 1/2	(77.5)	33 1/2	(85.1)	41	(104.1)	44 1/4	(112.4)	52 3/16	(132.6)	54	(137.2)
Water	Water Inlet Size - in (mm)	3/4	(19)	3/4	(19)	3/4	(19)	3/4	(19)	3/4	(19)	3/4	(19)
	Pressure (min-max) - psi (kPa)	30-120	(207-827)	30-120	(207-827)	30-120	(207-827)	30-120	(207-827)	30-120	(207-827)	30-120	(207-827)
	Flow Rate - gal/min (L/min)	9	(34)	9	(34)	9	(34)	9	(34)	9 & 12	(34 & 45)	9 & 12	(34 & 45)
	Drain Diameter (O.D.) - in (cm)	2 1/4	(5.7)	3	(7.6)	3	(7.6)	3	(7.6)	3	(7.6)	3	(7.6)
	Floor to Center of Drain - in (cm)	6	(15.2)	4 11/16	(11.9)	5	(12.7)	6 5/8	(16.8)	8 5/8	(21.8)	8 5/16	(21.1)
Electrical	Model	Volts / Hz / Phase / Wiring		Circuit Breaker Amps / Running Amps / Wire Size									
	-10	120 / 60 / 1 / 2 wire + ground		20 / 13 / #12	---	---	---	---	---	---	---	---	---
	-12	208-240 / 60 / 1 / 2 wire + ground		15 / 4 / #12	15 / 6.2 / #12	15 / 6.2 / #12	20 / 8.4 / #12	20 / 8.4 / #12	---	---	---	---	---
		208-240 / 60 / 3 / 3 wire + ground											
	-13	208-240 / 60 / 3 / 3 wire + ground		---	---	---	---	---	---	---	---	---	15 / 12 / #12
	-39	230 / 50 / 1 / 2 wire + ground		15 / 4 / 3.5 mm2	15 / 6.2 / 3.5 mm2	15 / 6.2 / 3.5 mm2	20 / 8.4 / 3.5 mm2	20 / 8.4 / 3.5 mm2	---	---	---	---	---
-59	230 / 50 / 1 / 2 wire + ground		15 / 4 / 3.5 mm2	15 / 6.2 / 3.5 mm2	15 / 6.2 / 3.5 mm2	20 / 8.4 / 3.5 mm2	20 / 8.4 / 3.5 mm2	---	---	---	---	---	
Installation	Min. Clearance Between Machines - in (cm)	1/2	(1.3)	1/2	(1.3)	1/2	(1.3)	1/2	(1.3)	1/2	(1.3)	1/2	(1.3)
	Min. Clearance Behind Machines - in (cm)	24	(61)	24	(61)	24	(61)	24	(61)	24	(61)	24	(61)
	Min. Concrete Thickness - in (cm)	6	(15.2)	6	(15.2)	6	(15.2)	8	(20.3)	8	(20.3)	12	(30.5)

## 1.2 Express Washers

		T-350		T-450		T-650		T-750		T-950		T-1450		
Capacity	Dry Weight Capacity - lb (kg)	20	(9.1)	30	(13.6 kg)	40	(18.1)	50	(22.7)	60	(27.2)	90	(40.8)	
	Cylinder Volume - cu ft (L)	2.7	(76.5)	3.8	(107.6 L)	6	(170)	6.5	(184.1)	9	(254.9)	13.7	(388)	
Speed	High Extract Speed - g (RPM)	200	(819)	200	(750 RPM)	200	(750)	200	(685)	200	(685)	200	(617)	
	Intermediate Extract Speed - g (RPM)	60	(449)	60	(411 RPM)	60	(411)	60	(375)	60	(375)	60	(338)	
	Washing Speed - g (RPM)	0.9	(55)	0.9	(50 RPM)	0.9	(50)	0.9	(43)	0.9	(43)	0.9	(39)	
	Motor Size - hp (kW)	1	(0.75)	2	(1.5 kW)	2	(1.5)	3	(2.2)	3	(2.2)	7.8	(5.8)	
Dimension	Cabinet Height - in (cm)	43 7/8	(111.4)	48 3/16	(122.4 cm)	53	(134.6)	55 3/8	(140.7)	55 3/8	(140.7)	62 3/8	(158.4)	
	Cabinet Width - in (cm)	26	(66)	29 7/8	(75.9 cm)	29 7/8	(75.9)	34 3/8	(87.3)	34 3/8	(87.3)	41 1/2	(105.4)	
	Cabinet Depth - in (cm)	28	(71.1)	28 1/4	(71.8 cm)	38 1/8	(96.8)	32 7/8	(83.5)	38 7/8	(98.7)	42 1/4	(107.3)	
	Door Opening - in (cm)	12 1/4	(31.1)	15 1/4	(38.7 cm)	15 1/4	(38.7)	19 1/4	(48.9)	19 1/4	(48.9)	19 1/4	(48.9)	
	Floor to Door Bottom - in (cm)	14 7/8	(37.8)	16 1/4	(41.3 cm)	16 1/4	(41.3)	16	(40.6)	16	(40.6)	19 5/16	(49.1)	
	Cylinder Diameter - in (cm)	21	(53.3)	25	(63.5 cm)	25	(63.5)	30	(76.2)	30	(76.2)	37	(94)	
	Cylinder Depth - in (cm)	13 1/2	(34.3)	13 3/8	(34 cm)	21 1/8	(53.7)	16	(40.6)	22	(55.9)	22	(55.9)	
Weight	Net Weight - lb (kg)	383	(173.7)	526	(238.6 kg)	744	(337.5)	925	(419.6)	1000	(453.6)	1322	(599.6)	
Shipping	Shipping Weight - lb (kg)	407	(184.6)	544	(246.8 kg)	766	(347.5)	952	(431.8)	1016	(460.8)	1364	(618.7)	
	Shipping Height - in (cm)	49 1/4	(125.1)	53 1/4	(135.3 cm)	58 3/4	(149.2)	61 1/2	(156.2)	61 1/2	(156.2)	69 1/4	(175.9)	
	Shipping Width - in (cm)	28 1/4	(71.8)	31 1/2	(80 cm)	31 1/2	(80)	36	(91.4)	36	(91.4)	43 1/8	(109.5)	
	Shipping Depth - in (cm)	33 1/2	(85.1)	33 1/2	(85.1 cm)	43 3/4	(111.1)	38	(96.5)	45 1/4	(114.9)	48	(121.9)	
Water	Water Inlet Size - in (mm)	3/4	(19)	3/4	(19 mm)	3/4	(19)	3/4	(19)	3/4	(19)	3/4	(19)	
	Pressure (min-max) - psi (kPa)	30-120	(207-827)	30-120	(207-827 kPa)	30-120	(207-827)	30-120	(207-827)	30-120	(207-827)	30-120	(207-827)	
	Flow Rate - gal/min (L/min)	9	(34)	9	(34)	9	(34)	9	(34)	9 & 12	(34 & 45)	9 & 12	(34 & 45)	
	Drain Diameter (O.D.) - in (cm)	2 1/4	(5.7)	3	(7.6 cm)	3	(7.6)	3	(7.6)	3	(7.6)	3	(7.6)	
	Floor to Center of Drain - in (cm)	6	(15.2)	5	(12.7 cm)	6 7/8	(17.5)	6 5/8	(16.8)	6 5/8	(16.8)	8 5/16	(21.1)	
Electrical	Model	Volts / Hz / Phase / Wiring		Circuit Breaker Amps / Running Amps / Wire Size										
	-12	208-240 / 60 / 1 / 2 wire + ground	15 / 6.2 / #12		15 / 6.2 / #12		15 / 6.2 / #12		20 / 8.4 / #12		20 / 12 / #12		30 / 15 / #10	
		208-240 / 60 / 3 / 3 wire + ground	15 / 6.2 / #12		15 / 6.2 / #12		15 / 6.2 / #12		20 / 8.4 / #12		20 / 12 / #12		30 / 15 / #10	
	-39	230 / 50 / 1 / 2 wire + ground	15 / 6.2 / 3.5 mm <sup>2</sup>		15 / 6.2 / 3.5 mm <sup>2</sup>		15 / 6.2 / 3.5 mm <sup>2</sup>		20 / 8.4 / 3.5 mm <sup>2</sup>		20 / 12 / 3.5 mm <sup>2</sup>		30 / 15 / 5.3 mm <sup>2</sup>	
-59	230 / 50 / 1 / 2 wire + ground	15 / 6.2 / 3.5 mm <sup>2</sup>		15 / 6.2 / 3.5 mm <sup>2</sup>		15 / 6.2 / 3.5 mm <sup>2</sup>		20 / 8.4 / 3.5 mm <sup>2</sup>		---		---		
Installation	Min. Clearance Between Machines - in (cm)	1/2	(1.3)	1/2	(1.3)	1/2	(1.3)	1/2	(1.3)	1/2	(1.3)	1/2	(1.3)	
	Min. Clearance Behind Machines - in (cm)	24	(61)	24	(61)	24	(61)	24	(61)	24	(61)	24	(61)	
	Min. Concrete Thickness - in (cm)	6	(15.2)	6	(15.2)	8	(20.3)	8	(20.3)	8	(20.3)	12	(30.5)	

**NOTE:**

For some models, Final Extract Speed is dependent on load and incoming voltage. Refer to the Electrical Installation section for more details.

## 2 INSTALLATION INSTRUCTIONS

All washers must be installed in accordance with all local, state and national building, electrical, plumbing and other codes in effect in the area.

**WARNING:**  
**THESE INSTALLATION AND SERVICING INSTRUCTIONS ARE FOR USE BY QUALIFIED PERSONNEL ONLY. TO AVOID INJURY AND ELECTRICAL SHOCK, DO NOT PERFORM ANY SERVICING OTHER THAN THAT CONTAINED IN THE OPERATING INSTRUCTIONS, UNLESS QUALIFIED.**

### 2.1 FOUNDATION REQUIREMENTS

#### **T-300 and 400:**

This machine is designed for use on or over bare concrete floor - not to be used above combustible flooring, such as carpet or wood. The washer must be securely bolted to a substantial concrete floor, or mounted upon a suitable base that is securely bolted to a substantial concrete floor.

**Grouting** is highly recommended, especially to the concrete surface. See Machine Grouting section for details.

#### **T-350, 450, 600, 650, 750, 900, 950, 1200, 1450, 1800:**

This machine is designed for use on or over bare concrete floor - not to be used above combustible flooring, such as carpet or wood. The washer must be securely bolted **and grouted** to a substantial concrete floor or mounted **and grouted** upon a suitable base that is securely bolted **and grouted** to a substantial concrete floor. See Machine Grouting section for details.

CARE MUST BE TAKEN WITH ALL FOUNDATION WORK TO ENSURE A STABLE UNIT INSTALLATION, ELIMINATING POSSIBILITIES OF EXCESSIVE VIBRATION.

Allow a minimum 24 inches (610 mm) of clearance behind the rear of the machine to provide access for motor service.

Installation on an isolated pad is NOT recommended. Consult a structural engineer for installations that will not be tied to a surrounding floor.

### 2.2 MOUNTING HEIGHT

A concrete pedestal or steel-mounting base that elevates the machine above the floor level is suggested to provide easy access to the loading door.

Suggested Amount to Elevate Washer:

T-300/350: approximately 8 inches (203 mm)

T-400/450/600: approximately 6 inches (152 mm)

T-650/750/900/950/1200/1450/1800: approximately 4 inches (102 mm)

Contact a Dexter laundry equipment distributor for recommended steel

mounting bases. Available steel mounting bases:

Washer	Part Number	Height
T-300	9945-094-003	8" (203 mm) Single Base
T-300	9945-094-004	8" (203 mm) Double Base
T-350	9945-121-001	8" (203 mm) Single Base
T-400	9945-089-001	6" (152 mm) Single Base
T-400	9945-089-002	6" (152 mm) Double Base
T-450	9945-123-001	6" (152 mm) Single Base
T-600	9945-098-001	6" (152 mm) Single Base
T-650	9945-145-001	6" (152 mm) Single Base
T-750	9945-117-001	6" (152 mm) Single Base
T-900/950	9945-103-001	4" (103 mm) Single Base
T-900/950	9945-118-001	6" (152 mm) Single Base
T-1200	9945-124-001	6" (152 mm) Single Base
T-1450	9945-145-001	4" (103 mm) Single Base
T-1800	9945-159-001	4" (103 mm) Single Base

If an elevated concrete pedestal is desired, it should be embedded and tied into the existing floor. DO NOT install a pad on top of the existing floor. Cut through existing floor as shown below. See Machine Mounting Detail Figures for floor thickness and bolt sizes.

EXPANSION ANCHORS ARE NOT RECOMMENDED FOR USE IN CONCRETE PEDESTALS BECAUSE THE ANCHORS ARE TOO CLOSE TO AN EDGE, CAUSING IT TO BREAK OUT.

### 2.3 FOUNDATION AND PAD OPTIONS

All installations require reinforced concrete floors. Refer to appropriate model Machine Mounting Detail Figures 1-1, 1-2 and 1-3 for minimum floor thickness and minimum pad sizes. See mounting diagram for overall washer dimensions.

Refer to appropriate model Figure 1-4 for side by side mounting dimensions.

### 2.3.1 WASHER INSTALLATION ON EXISTING FLOOR:

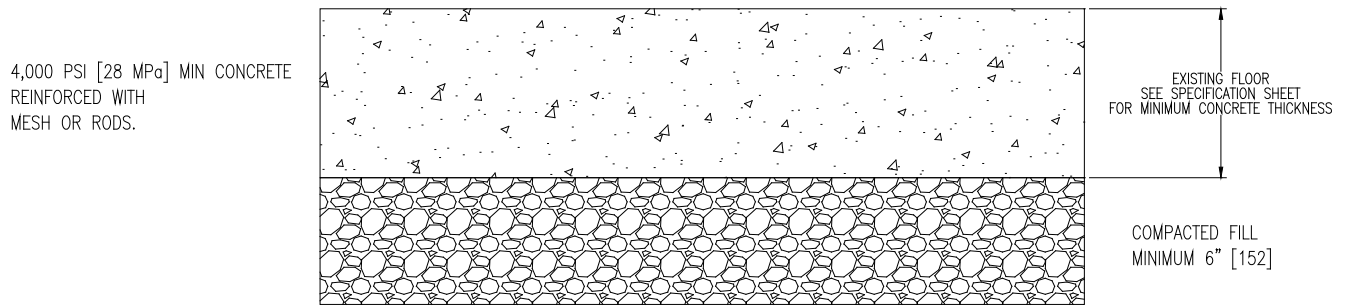

### 2.3.2 WASHER INSTALLATION ON NEW FLOOR:

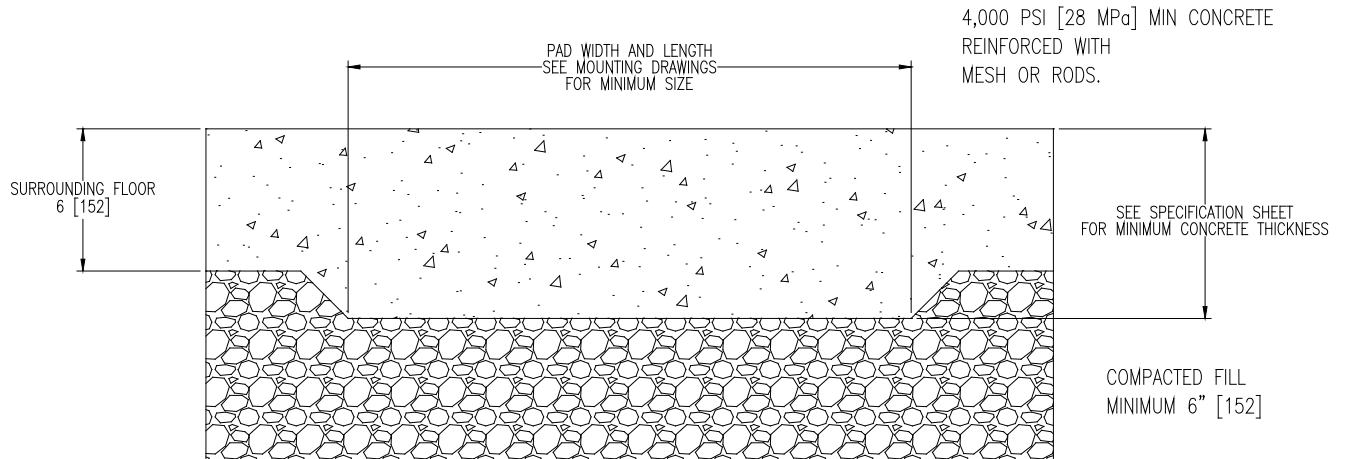

### 2.3.3 NEW PAD TIED TO EXISTING FLOOR:

If the existing floor is not reinforced concrete that meets the minimum thickness requirements, DO NOT install a pad on top of the existing floor. The existing floor and the machine pad must be tied together as one piece as follows:

- 1) Cut an opening through the existing floor that is wider and deeper than the washer as shown below. See Machine Mounting Details for dimensions.
- 2) Excavate to a depth that allows for 6" [152] minimum of compacted fill plus the minimum required concrete thickness. Also excavate 2" [51] under the existing floor so that the new concrete is poured under the floor as well.
- 3) Back fill with clean fill dirt and compact dirt, making sure to allow for the minimum thickness concrete pad to be poured.
- 4) Drill holes around the perimeter of the existing floor to install reinforcing bars to tie the new pad to the existing floor. Drill 2-1/2" [64] deep into the existing floor on 12" [305] centers around the entire perimeter.
- 5) Clean holes and fill half-way with acrylic adhesive rated for commercial-grade machine installations.

- 6) Use #4 (60 ksi) reinforcing bar to tie the new pad to the existing floor. Tie the bars together at intersections and use supports to hold bars in the proper depth in the pad.
- 7) After adhesive has cured, pour 4000 psi concrete up to level with the existing floor plus any extra elevated pedestal desired 4-10" [102-254]. Concrete must be done in one pour so that the entire pad cures as one piece.

### 2.3.3.1 NEW PAD TIED TO EXISTING FLOOR (LEVEL WITH FLOOR):

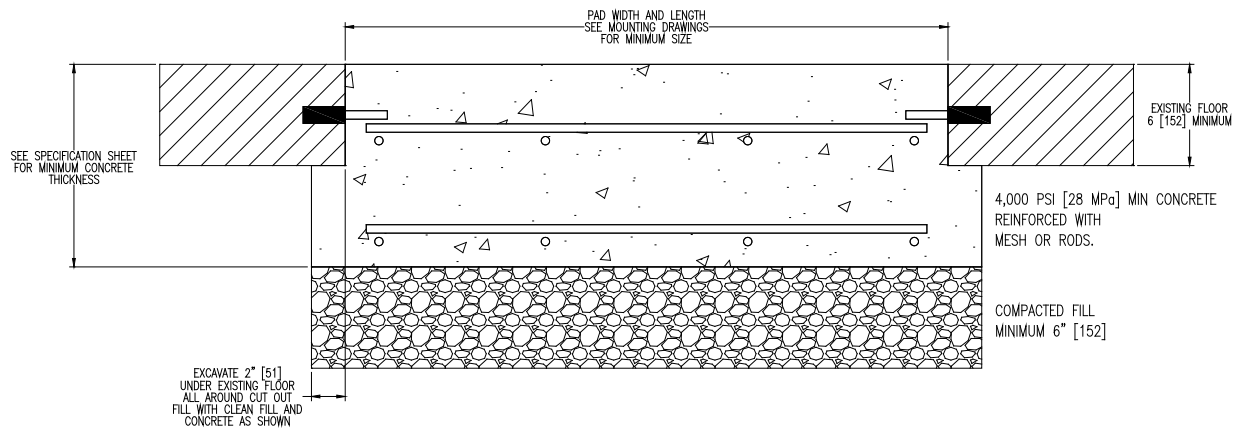

### 2.3.3.2 NEW RAISED CONCRETE PEDESTAL TIED TO EXISTING FLOOR:

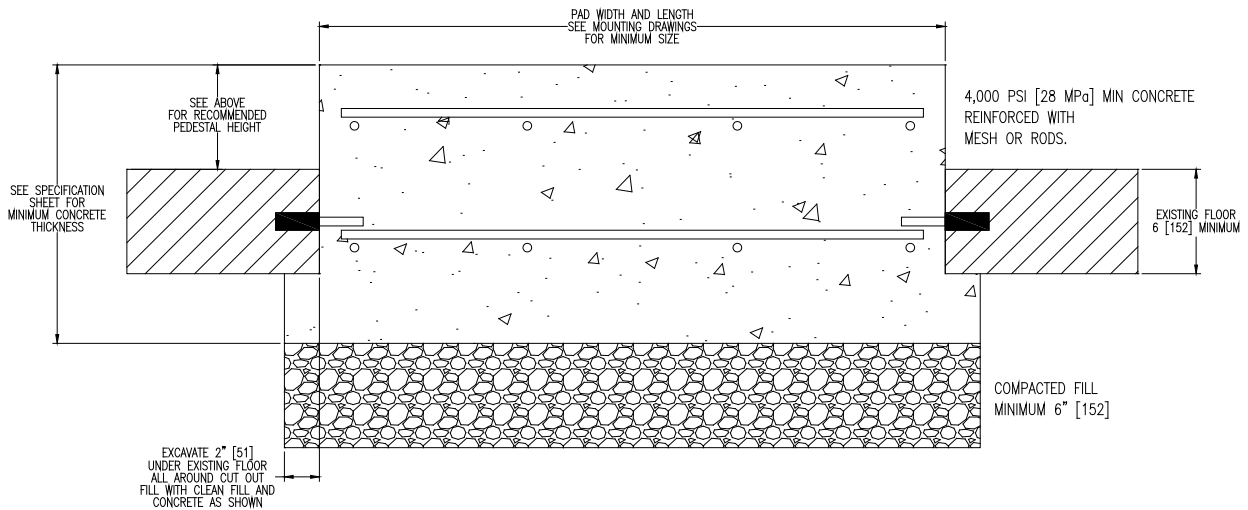

### 2.3.4 STEEL MOUNTING BASE ON CONCRETE FLOOR:

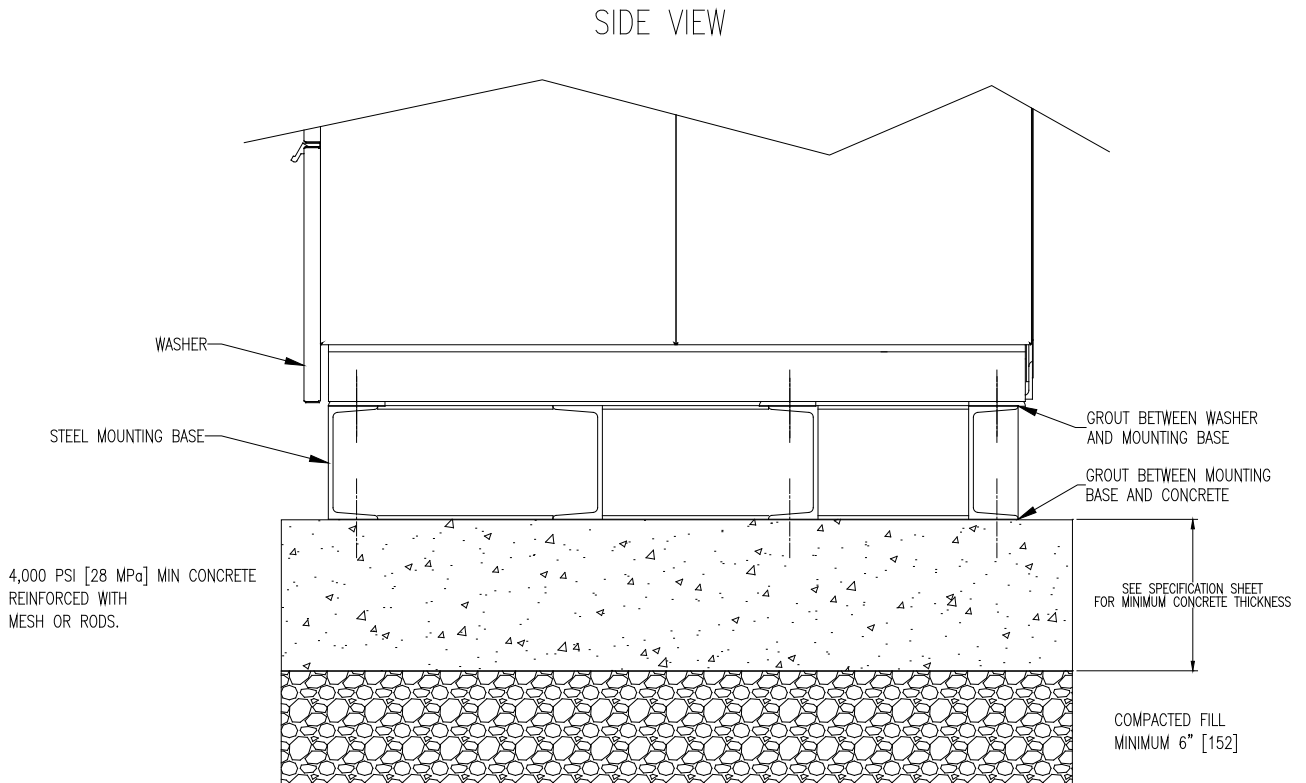

## 2.4 MACHINE ANCHORING

All installations require concrete floors and quality grade anchor bolts or expansion anchors. Mounting hardware is not provided with the machines. Refer to appropriate model Machine Mounting Detail Figures 1-1, 1-2 and 1-3 for floor thickness and bolt sizes. See mounting diagram for overall washer dimensions.

EXPANSION ANCHORS ARE NOT RECOMMENDED FOR USE IN RAISED CONCRETE PEDESTALS BECAUSE THE ANCHORS ARE TOO CLOSE TO AN EDGE, CAUSING IT TO BREAK OUT.

ANCHORING OPTIONS:

*2.4.1 Cast in place bolts headed by square fish plates. See Machine Mounting Detail Figures 1-1 thru 1-3 for exact washer model.*

*Or after concrete has completely cured:*

*2.4.2 Use Hilti Adhesive System 'HAS' Rods and adhesive capsules. See Machine Mounting Detail Figures 1-1 thru 1-3 for exact washer model.*

*2.4.3 Or use an equivalently rated epoxy or acrylic adhesive anchor.*

As an installation aid, the anchor pattern can be found on the back panel of the washers and can be used as a template. Compare panel to the mounting dimension drawing to find the right holes.  
Example:

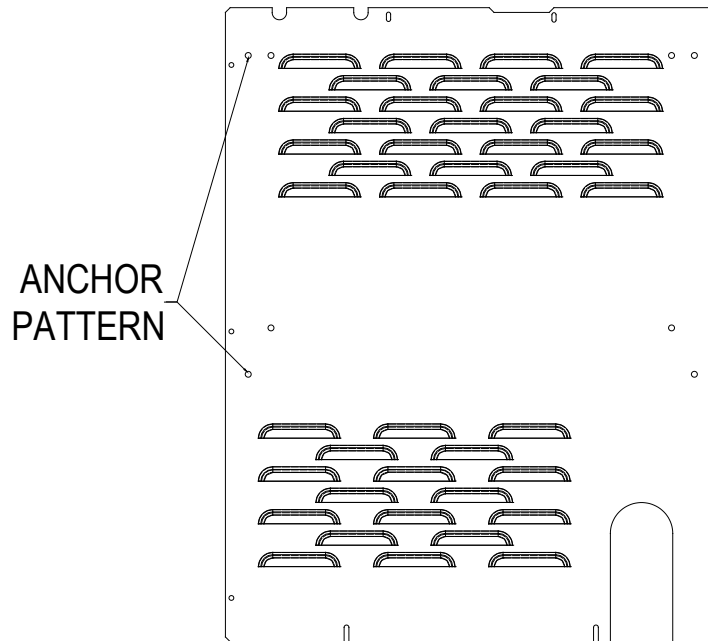

## 2.5 MACHINE GROUTING

After concrete has cured completely and anchors have cured completely into place:

*2.5.1 Position washer over the mounting anchors.*

*2.5.2 Raise the washer 1/2" [12.7] off the mounting surface and place spacers under the corners of the washer base.*

*2.5.3 Level the washer, leaving washer at least 1/2" [12.7] off the mounting surface.*

Do not permanently support the washer with spacers under the corners. Machine must be grouted, and spacers must be removed.

*2.5.4 Mix non-shrinking machinery grout according to the grout instructions. The grout should not be too runny or too firm. **Completely fill** the 1/2" [12.7] space between the washer base and the mounting surface. Force grout under all base angles and plates until completely filled. Fill around all anchor bolts.*

*2.5.5 Finger tighten all nuts to anchor bolts.*

*2.5.6 When the grout has started to stiffen (but before it is cured), remove the spacers from the corners and allow the washer to settle into the wet grout. Fill in any voids as necessary with additional grout.*

*2.5.7 Allow grout to completely cure, then tighten all nuts to securely fasten the washer to the grouted mounting surface.*

*2.5.8 Retighten nuts after 5 days of operation and check quarterly.*

If using a steel mounting base, first grout the steel mounting base to the concrete floor using the above steps, then repeat the steps for mounting and grouting the washer to the steel mounting base.

## 2.6 FLOOR LOAD DATA

DEXTER DYNAMIC LOADING CHART										
Model	Dry Weight Capacity (lb [kg])	Extract Speed (RPM)	Extract G-Force	Maximum Static Load (lb [kN])	Static Load Pressure (lb/sq ft [kN/ sq m])	Total Dynamic Load (lb [kN])	Dynamic Load Pressure (lb/sq ft [kN/ sq m])	Dynamic Load Frequency (Hz)	Maximum Vertical Load (lb [kN])	Maximum Moment About Washer Base (ft*lbs [m-kN])
T-300	20 [9.1]	579	100	381 [1.7]	91 [4.3]	400 [1.8]	95 [4.6]	9.7	737 [3.3]	785 [1.1]
T-350	20 [9.1]	819	200	447 [2.0]	94 [4.5]	800 [3.6]	168 [8.0]	13.7	1203 [5.4]	1571 [2.1]
T-400	30 [13.6]	531	100	527 [2.3]	101 [4.8]	500 [2.7]	115 [5.5]	8.9	1062 [4.7]	1316 [1.8]
T-450	30 [13.6]	750	200	618 [2.7]	113 [5.4]	1200 [5.3]	220 [10.5]	12.5	1756 [7.8]	2631 [3.6]
T-600	40 [18.1]	531	100	686 [3.1]	97 [4.6]	800 [3.6]	113 [5.4]	8.9	1398 [6.2]	1754 [2.4]
T-650	40 [18.1]	750	200	882 [3.9]	134 [6.4]	1600 [7.1]	243 [11.6]	12.5	2384 [10.6]	3508 [4.8]
T-750	50 [22.7]	685	200	1119 [5.0]	166 [7.9]	2000 [8.9]	297 [14.2]	11.4	2970 [13.2]	4667 [6.3]
T-900	60 [27.2]	485	100	1170 [5.2]	146 [7.0]	1200 [5.3]	149 [7.2]	8.1	2224 [9.9]	2800 [3.8]
T-950	60 [27.2]	685	200	1206 [5.4]	150 [7.2]	2400 [10.7]	299 [14.3]	11.4	3460 [15.4]	5600 [7.6]
T-1200	80 [36.3]	485	100	1288 [5.7]	136 [6.5]	1600 [7.1]	169 [8.1]	8.1	2702 [12.0]	4067 [5.5]
T-1450	90 [40.8]	617	200	1635 [7.3]	163 [7.8]	3600 [16.0]	360 [17.2]	10.3	5012 [22.3]	9413 [12.8]
T-1800	120 [54.4]	436	100	1818 [8.1]	158 [7.6]	2400 [10.7]	208 [10]	7.3	3935 [17.5]	6275 [8.5]

**Note:** The out-of-balance loading conditions may vary depending on load size, model and material.

## 2.7 MOUNTING DETAILS

### 2.7.1 T-300 Machine Mounting Detail

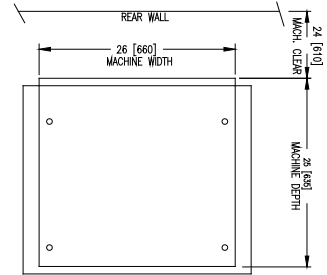
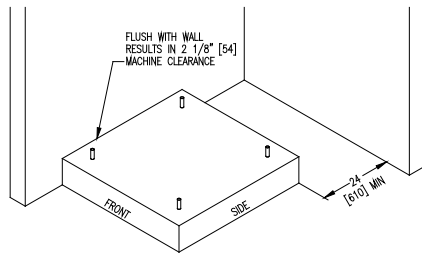

**FLOOR OUTLINE**  
Figure 1-2

ANCHORS: 1/2" X 8" GRADE 5 BOLTS HEADED BY 4" SQ. FISH PLATE OR EQUIV. (1 7/8" BOLT PROTRUSION)      ANCHORS: 14mm X 200mm GRADE 5 BOLTS HEADED BY 100mm SQ. FISH PLATE OR EQUIV. (48mm BOLT PROTRUSION)

OR  
'HILTI' ADHESIVE ANCHORING SYSTEM.  
HILTI 'HAS' SUPER RODS 1/2 X 8 AND ADHESIVE CAPSULES  
FOR MORE INFORMATION CALL  
HILTI CUSTOMER SERVICE  
1-800-879-8000

OR  
EQUIVALENT EPOXY OR  
ACRYLIC ADHESIVE ANCHOR

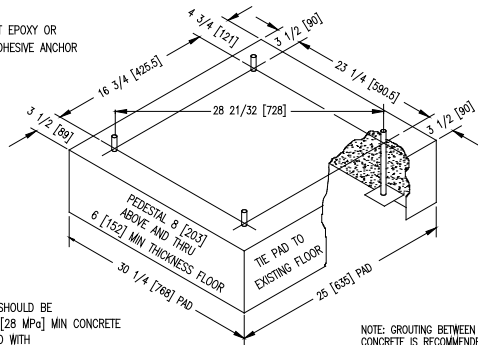

PEDESTAL SHOULD BE  
4,000 PSI [28 MPa] MIN CONCRETE  
REINFORCED WITH  
MESH OR RODS.

NOTE: GROUTING BETWEEN BASE AND  
CONCRETE IS RECOMMENDED.

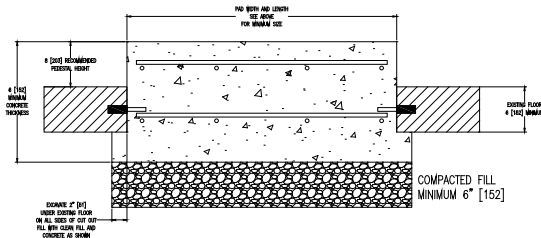

**RAISED CONCRETE PEDESTAL MOUNTING OPTION**  
Figure 1-1

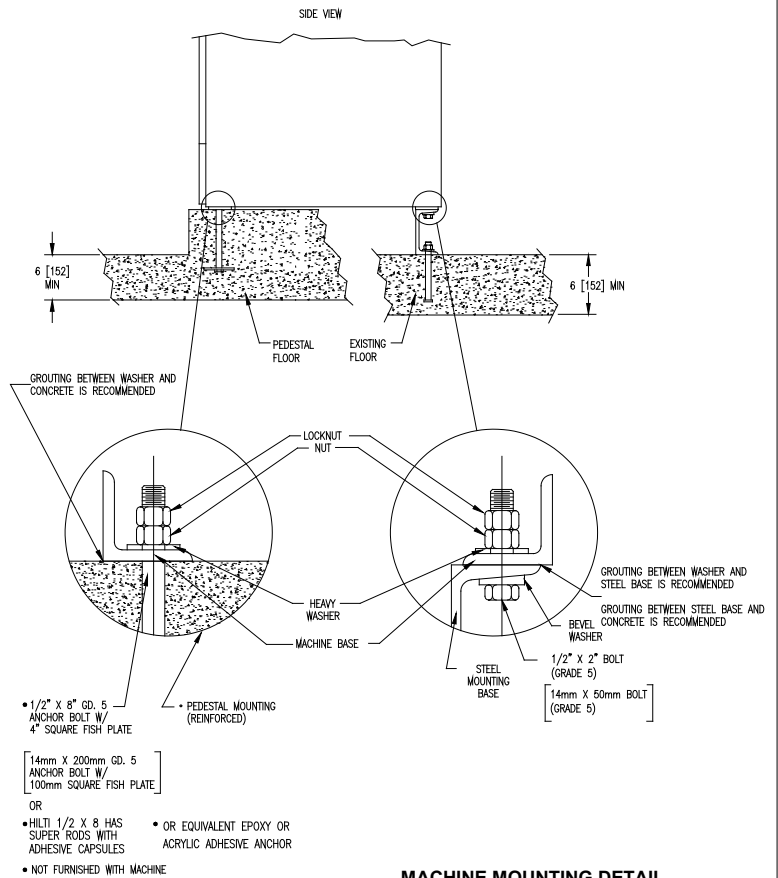

• 1/2" X 8" GD. 5 ANCHOR BOLT W/ 4" SQUARE FISH PLATE

[14mm X 200mm GRADE 5 ANCHOR BOLT W/ 100mm SQUARE FISH PLATE]

- OR
- HILTI 1/2 X 8 HAS SUPER RODS WITH ADHESIVE CAPSULES
  - OR EQUIVALENT EPOXY OR ACRYLIC ADHESIVE ANCHOR
  - NOT FURNISHED WITH MACHINE

**MACHINE MOUNTING DETAIL**  
Figure 1-3

## 2.7.2 T-300 Machine Side By Side Mounting Detail

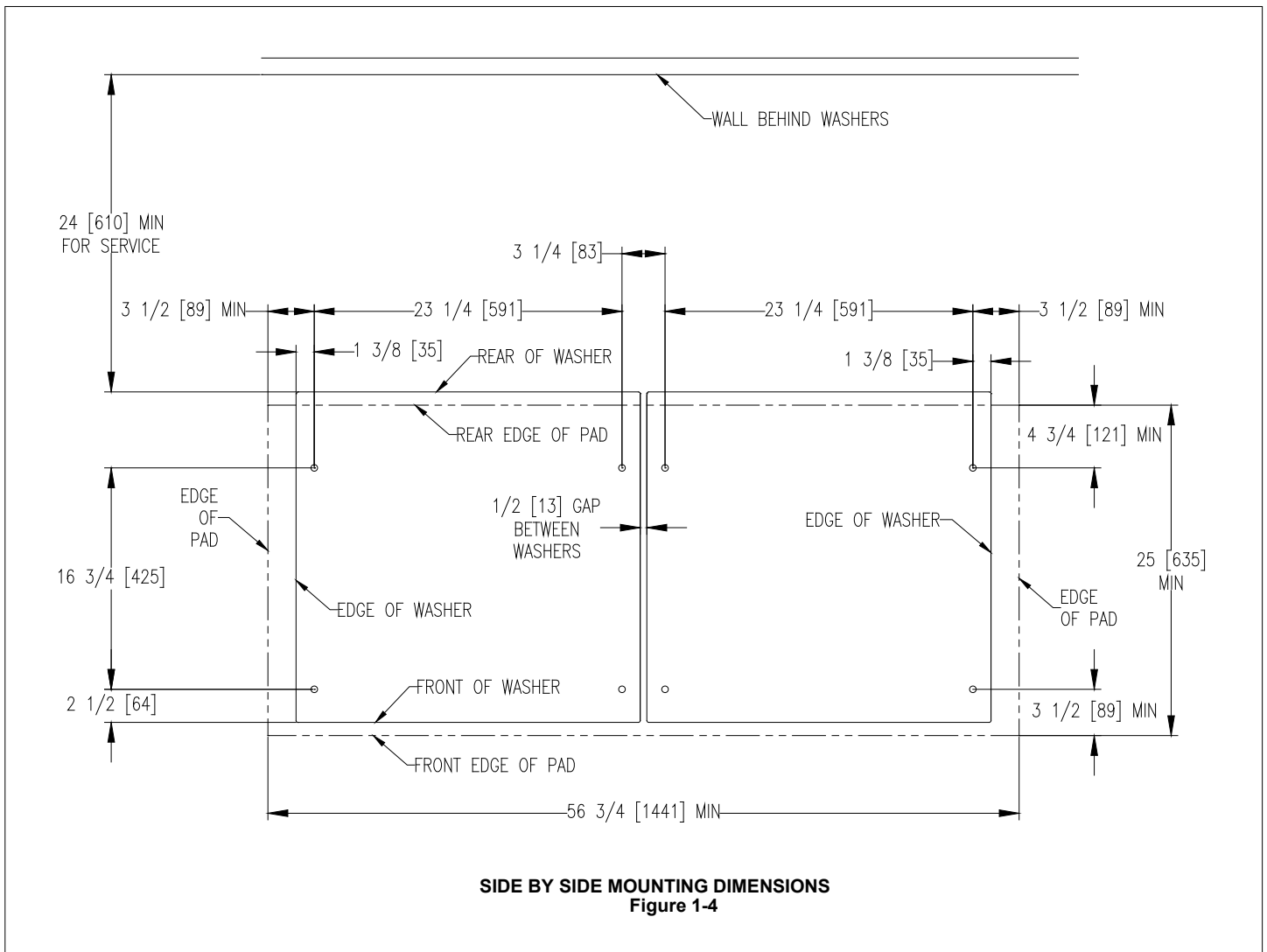

2.7.3 T-300 Industrial Washer Dimensions

T-300 INDUSTRIAL WASHER  
MOUNTING DIMENSIONS

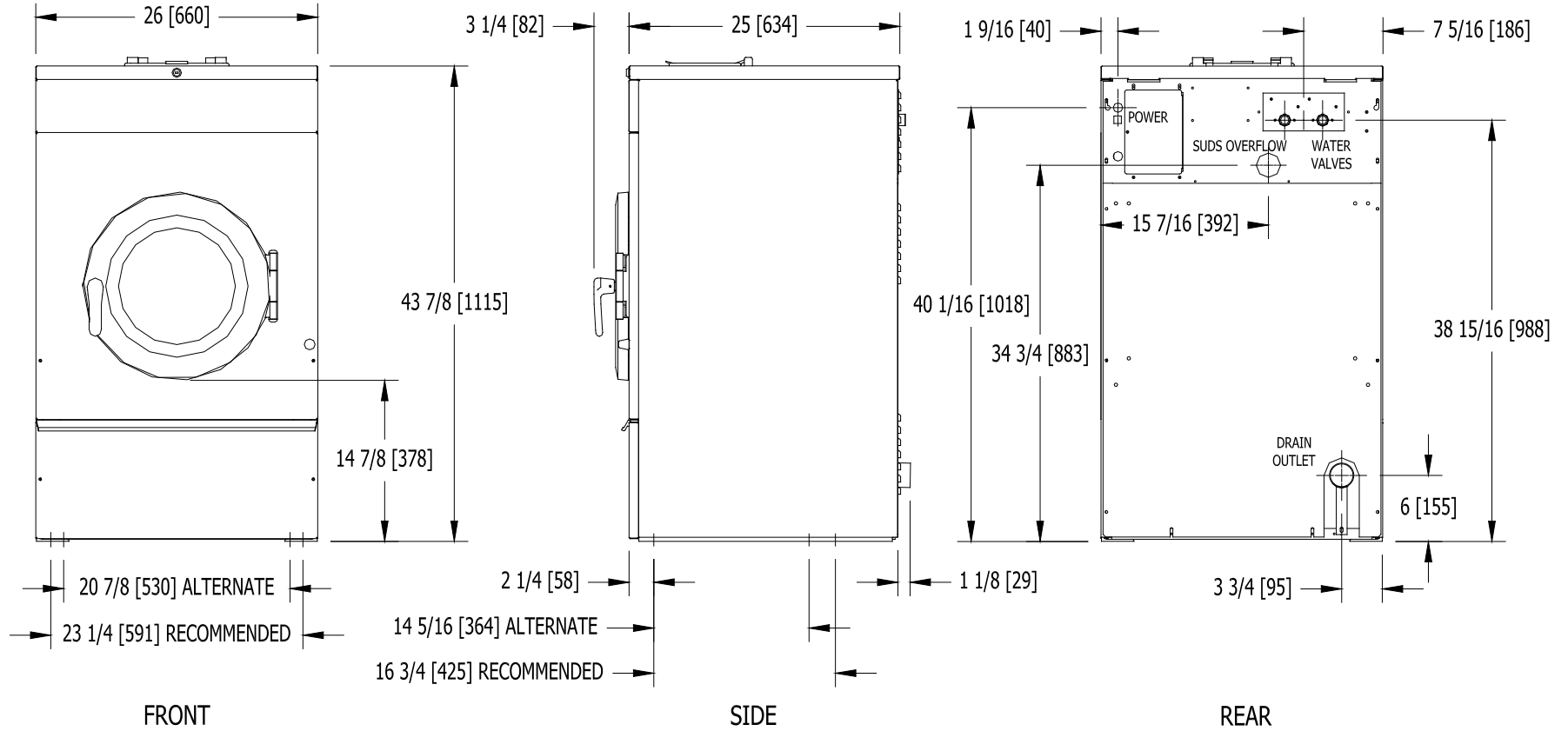

## 2.7.4 T-350 Machine Mounting Detail

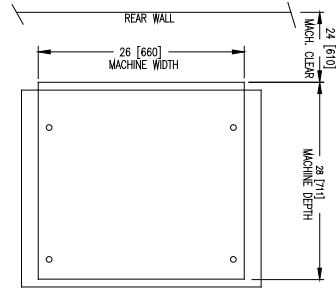
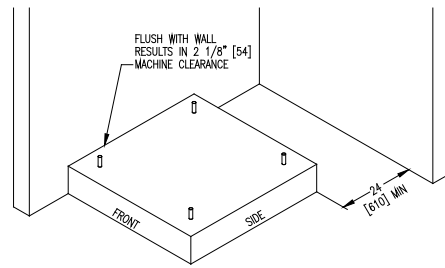

**FLOOR OUTLINE**  
Figure 1-2

5/8" X 8" CD. 8 BOLTS  
HEADED BY 4" SQ. FISH PLATE OR EQUIV.  
(1 7/8" BOLT PROTRUSION)

[ANCHORS: 16mm X 200mm GRADE 8 BOLTS  
HEADED BY 100 SQ. FISH PLATE OR EQUIV.  
(48mm BOLT PROTRUSION)]

OR  
"HILTI" ADHESIVE ANCHORING SYSTEM.  
HILTI "HAS" SUPER RODS 5/8 X 8 AND ADHESIVE CAPSULES  
FOR MORE INFORMATION CALL  
HILTI CUSTOMER SERVICE  
1-800-879-8000

OR  
EQUIVALENT EPOXY OR  
ACRYLIC ADHESIVE ANCHOR

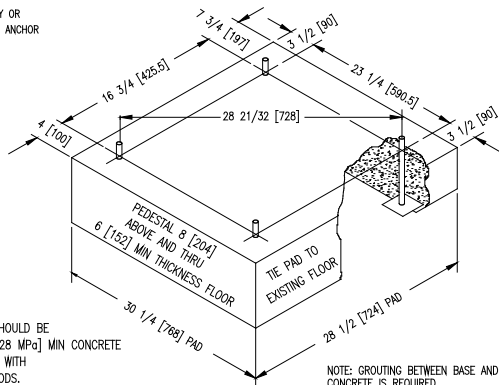

PEDESTAL SHOULD BE  
4,000 PSI [28 MPa] MIN CONCRETE  
REINFORCED WITH  
MESH OR RODS.

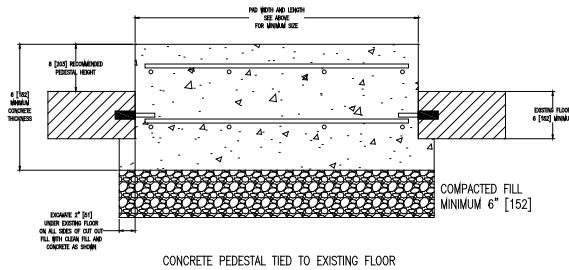

**RAISED CONCRETE PEDESTAL MOUNTING OPTION**

Figure 1-1

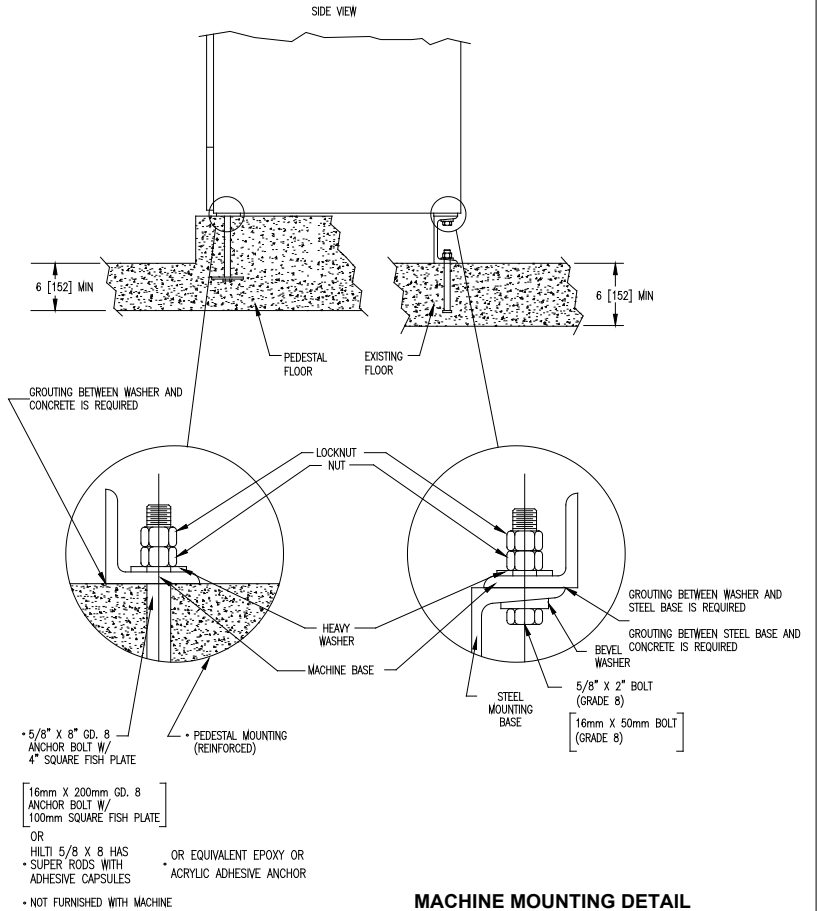

• 5/8" X 8" CD. 8  
ANCHOR BOLT W/  
4" SQUARE FISH PLATE

[16mm X 200mm GD. 8  
ANCHOR BOLT W/  
100mm SQUARE FISH PLATE]

OR  
HILTI 5/8 X 8 HAS  
SUPER RODS WITH  
ADHESIVE CAPSULES

• NOT FURNISHED WITH MACHINE

• PEDESTAL MOUNTING  
(REINFORCED)

OR EQUIVALENT EPOXY OR  
ACRYLIC ADHESIVE ANCHOR

**MACHINE MOUNTING DETAIL**

Figure 1-3

### 2.7.5 T-350 Machine Side By Side Mounting Detail

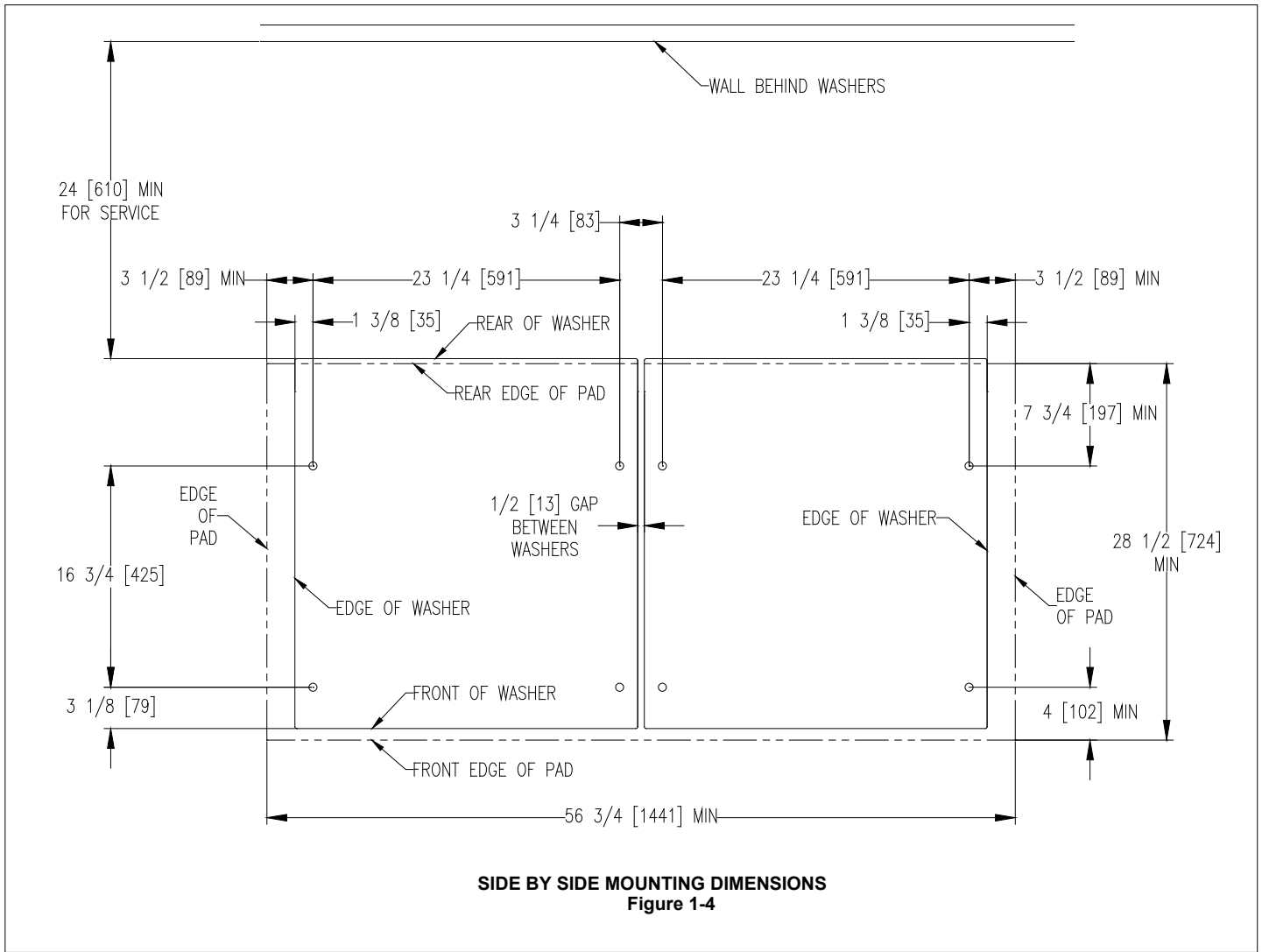

2.7.6 T-350 Industrial Washer Dimensions

T-350 INDUSTRIAL WASHER  
MOUNTING DIMENSIONS

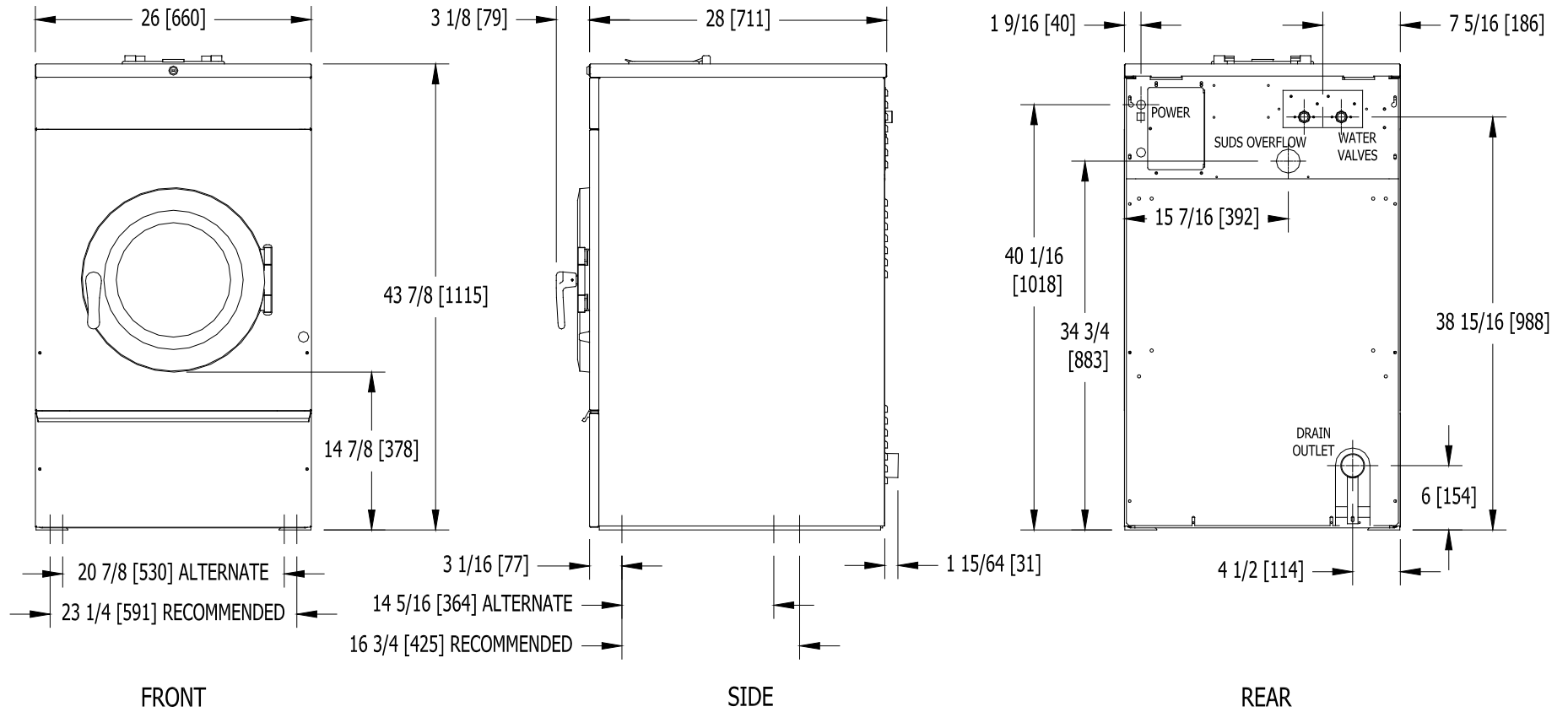

## 2.7.7 T-400 Machine Mounting Detail

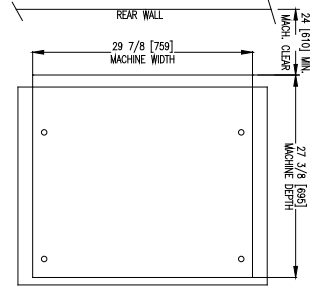
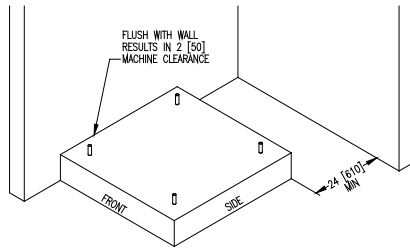

**FLOOR OUTLINE**  
Figure 1-2

1/2" X 8" GD. 5 BOLTS  
HEADED BY 4" SQ. FISH PLATE OR EQUIV.  
(1 7/8" BOLT PROTRUSION)

ANCHORS: 14mm X 200mm GRADE 5 BOLTS  
HEADED BY 100mm SQ. FISH PLATE OR EQUIV.  
(46mm BOLT PROTRUSION)

OR  
"HILTI" ADHESIVE ANCHORING SYSTEM  
HILTI "HAS" SUPER RODS 1/2 X 8 AND ADHESIVE CAPSULES  
FOR MORE INFORMATION CALL  
HILTI CUSTOMER SERVICE  
1-800-879-8000  
OR  
EQUIVALENT EPOXY OR  
ACRYLIC ADHESIVE ANCHOR

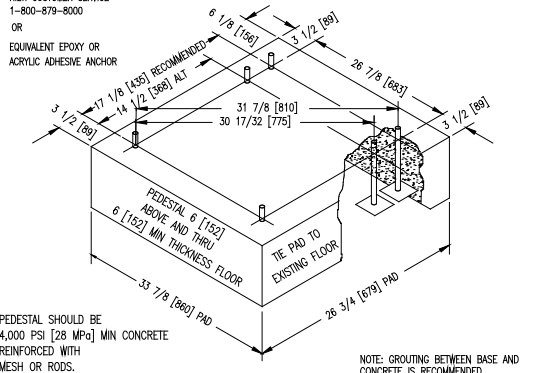

PEDESTAL SHOULD BE  
4,000 PSI [28 MPa] MIN CONCRETE  
REINFORCED WITH  
MESH OR RODS.

NOTE: GROUTING BETWEEN BASE AND  
CONCRETE IS RECOMMENDED.

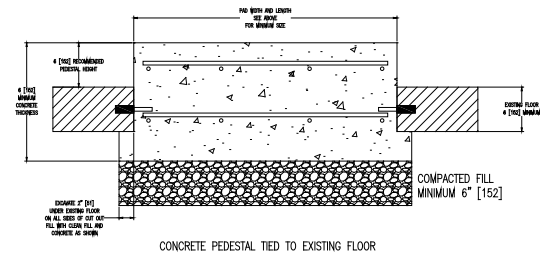

**RAISED CONCRETE PEDESTAL MOUNTING OPTION**  
Figure 1-1

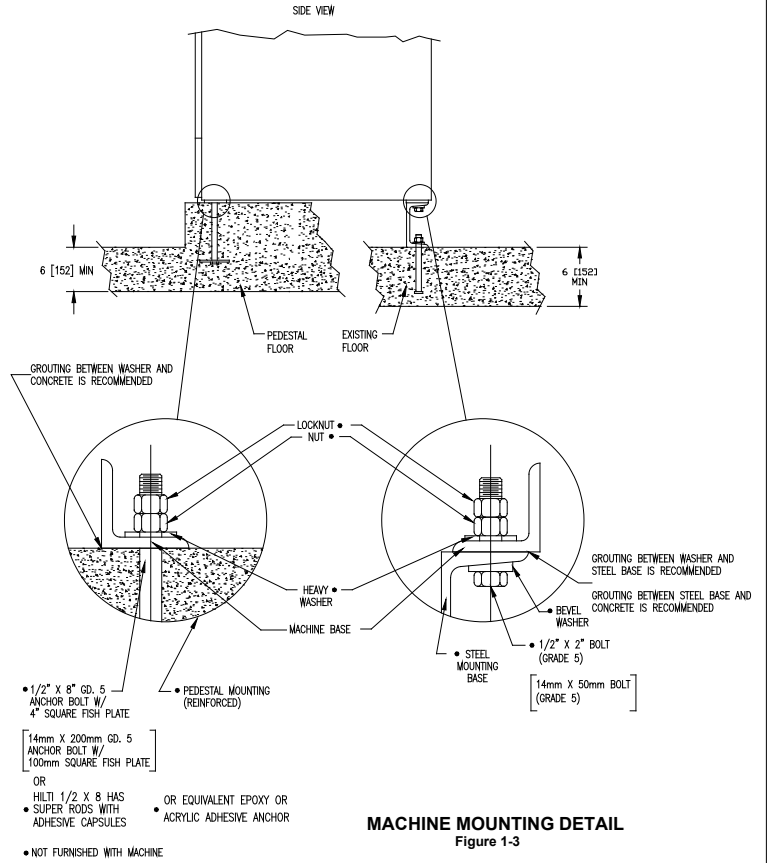

- 1/2" X 8" GD. 5 ANCHOR BOLT W/ 4" SQUARE FISH PLATE
- 14mm X 200mm GD. 5 ANCHOR BOLT W/ 100mm SQUARE FISH PLATE
- OR
- HILTI 1/2 X 8 HAS SUPER RODS WITH ADHESIVE CAPSULES
- OR EQUIVALENT EPOXY OR ACRYLIC ADHESIVE ANCHOR
- NOT FURNISHED WITH MACHINE

**MACHINE MOUNTING DETAIL**  
Figure 1-3

## 2.7.8 T-400 Machine Side By Side Mounting Detail

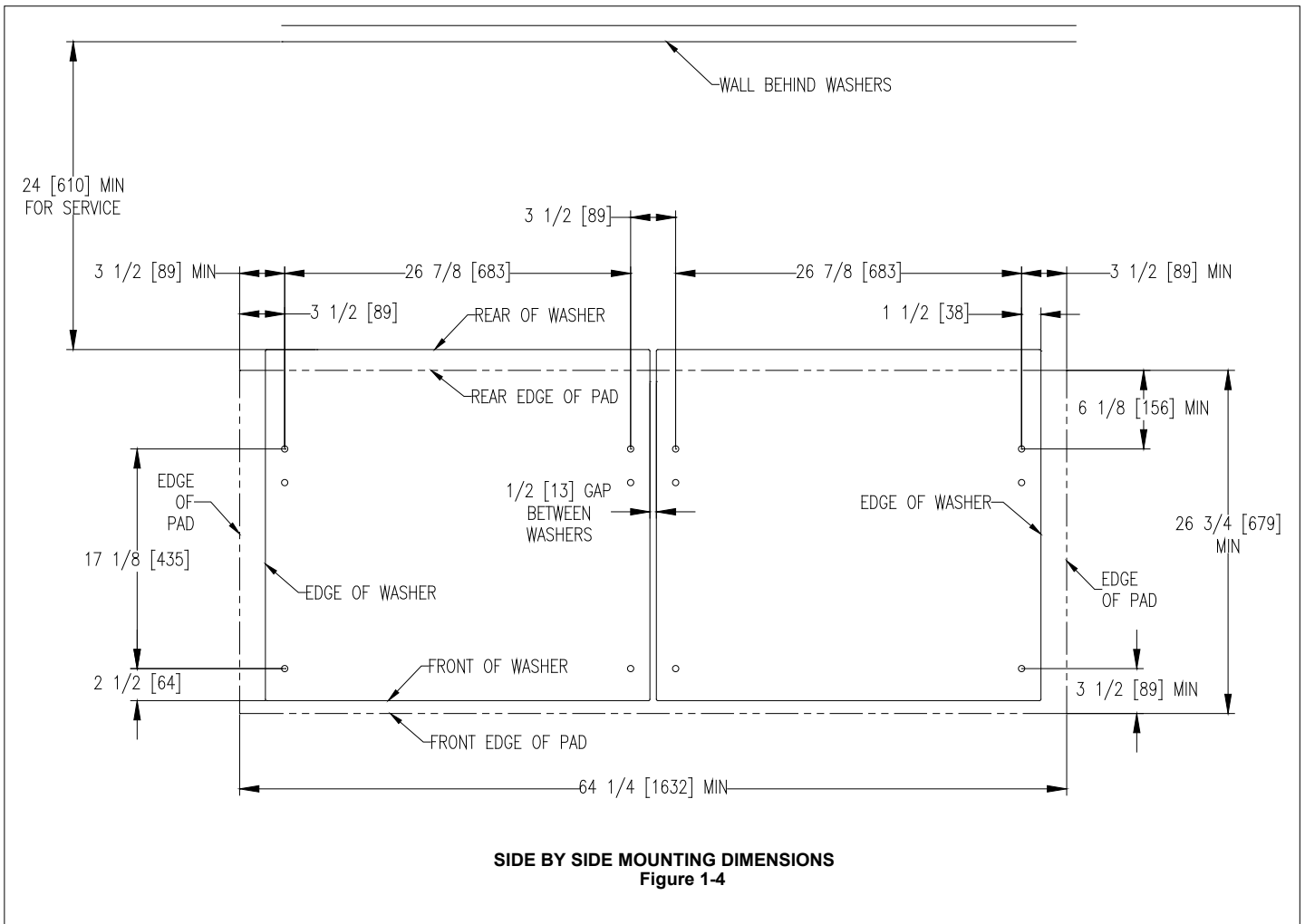

2.7.9 T-400 Industrial Washer Dimensions

T-400 INDUSTRIAL WASHER  
MOUNTING DIMENSIONS

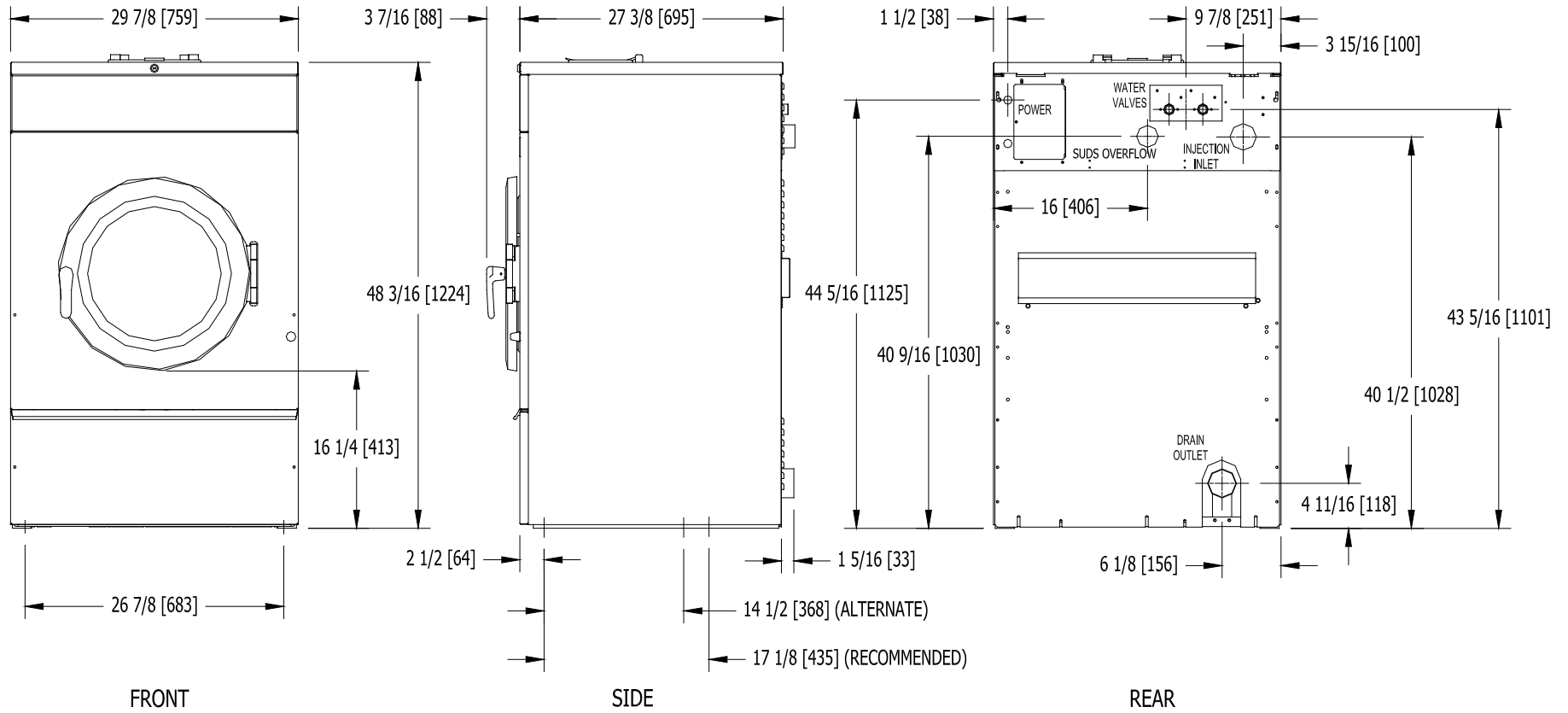

## 2.7.10 T-450 Machine Mounting Detail

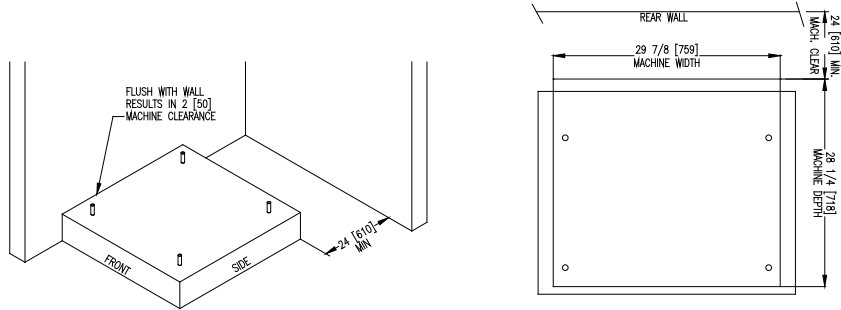

**FLOOR OUTLINE**  
Figure 1-2

5/8" X 8" GD. 8 BOLTS  
HEADED BY 4" SQ. FISH PLATE OR EQUIV.  
(1 7/8" BOLT PROTRUSION)

[ANCHORS: 16mm X 200mm GRADE 8 BOLTS  
HEADED BY 100 SQ. FISH PLATE OR EQUIV.  
(48mm BOLT PROTRUSION)]

OR  
'HILTI' ADHESIVE ANCHORING SYSTEM.  
HILTI 'HAS' SUPER RODS 5/8 X 8 AND ADHESIVE CAPSULES  
FOR MORE INFORMATION CALL  
HILTI CUSTOMER SERVICE  
1-800-879-8000

OR  
EQUIVALENT EPOXY OR  
ACRYLIC ADHESIVE ANCHOR

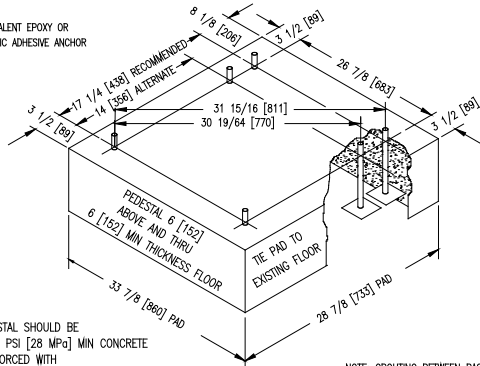

PEDESTAL SHOULD BE  
4,000 PSI [28 MPa] MIN CONCRETE  
REINFORCED WITH  
MESH OR RODS.

NOTE: GROUTING BETWEEN BASE AND  
CONCRETE IS REQUIRED.

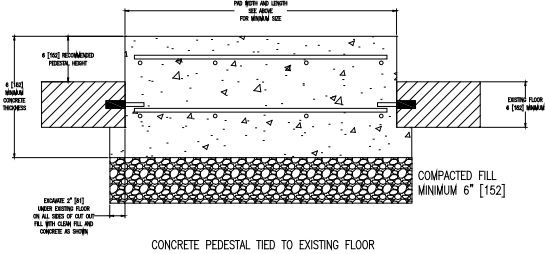

**RAISED CONCRETE PEDESTAL MOUNTING OPTION**  
Figure 1-1

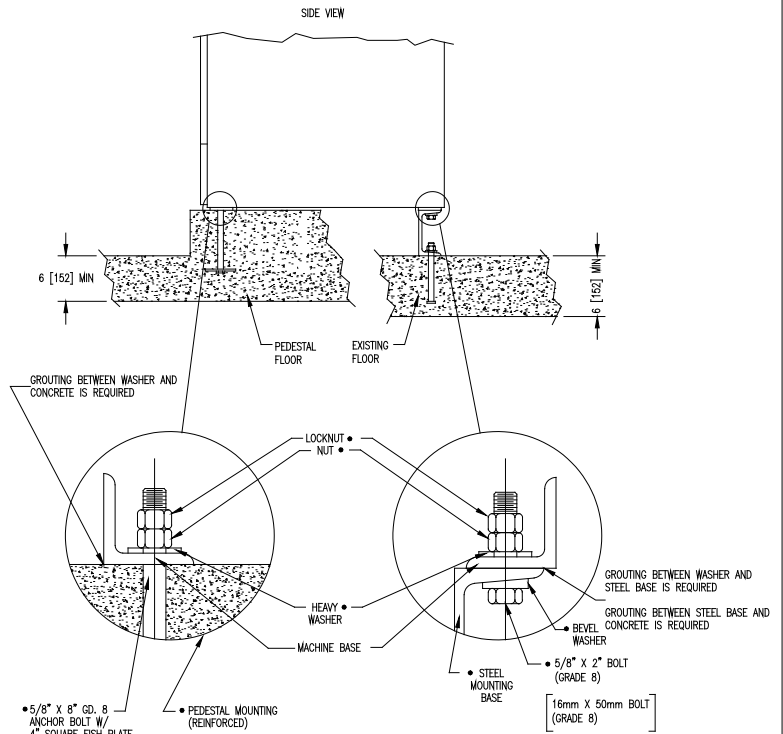

• 5/8" X 8" GD. 8  
ANCHOR BOLT W/  
4" SQUARE FISH PLATE

[16mm X 200mm GD. 8  
ANCHOR BOLT W/  
100mm SQUARE FISH PLATE]

OR  
HILTI 5/8 X 8 HAS  
• SUPER RODS WITH  
ADHESIVE CAPSULES

• OR EQUIVALENT EPOXY OR  
• ACRYLIC ADHESIVE ANCHOR

• NOT FURNISHED WITH MACHINE

**MACHINE MOUNTING DETAIL**  
Figure 1-3

### 2.7.11 T-450 Machine Mounting Detail

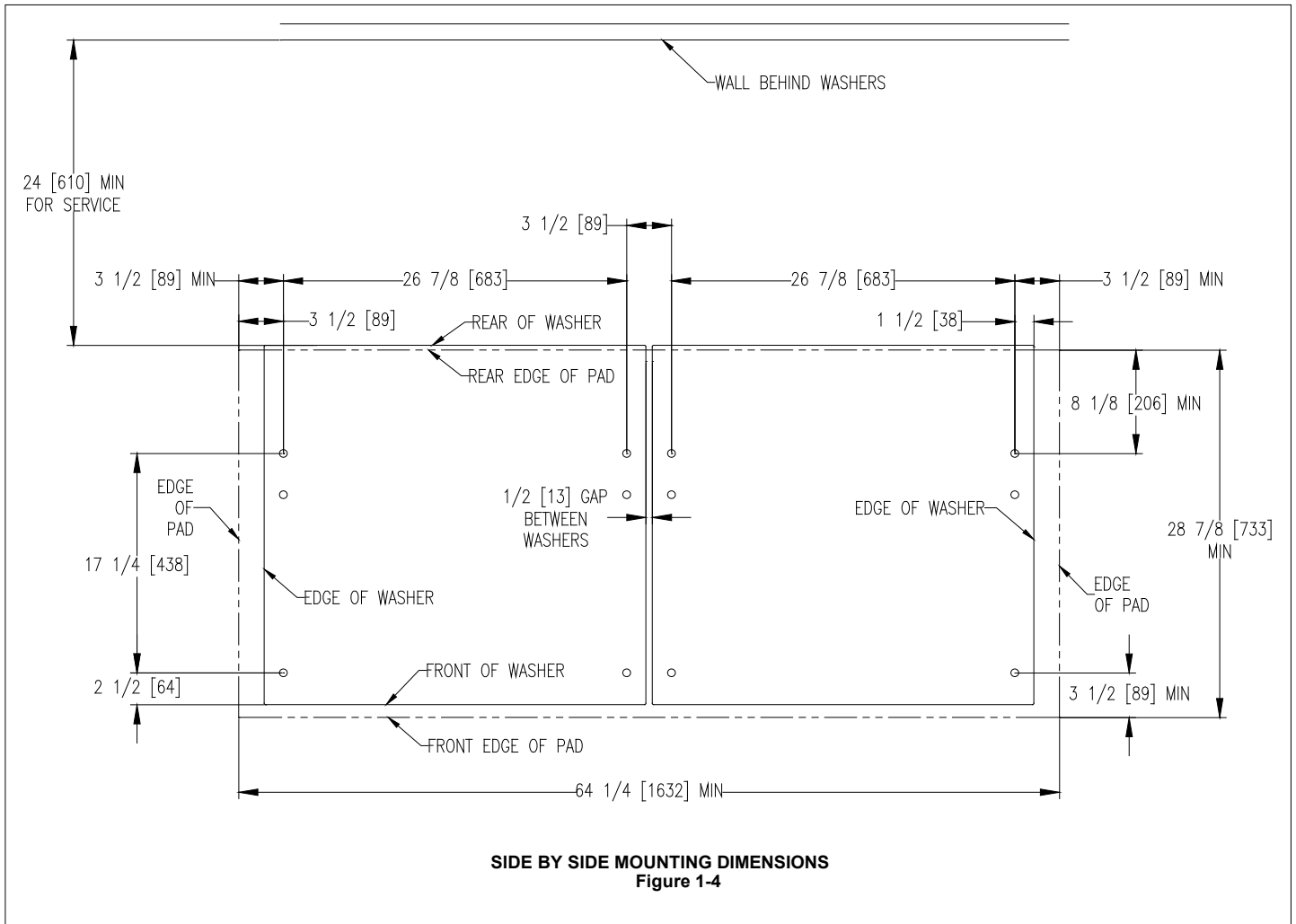

2.7.12 T-450 Industrial Washer Dimensions

T-450 INDUSTRIAL WASHER  
MOUNTING DIMENSIONS

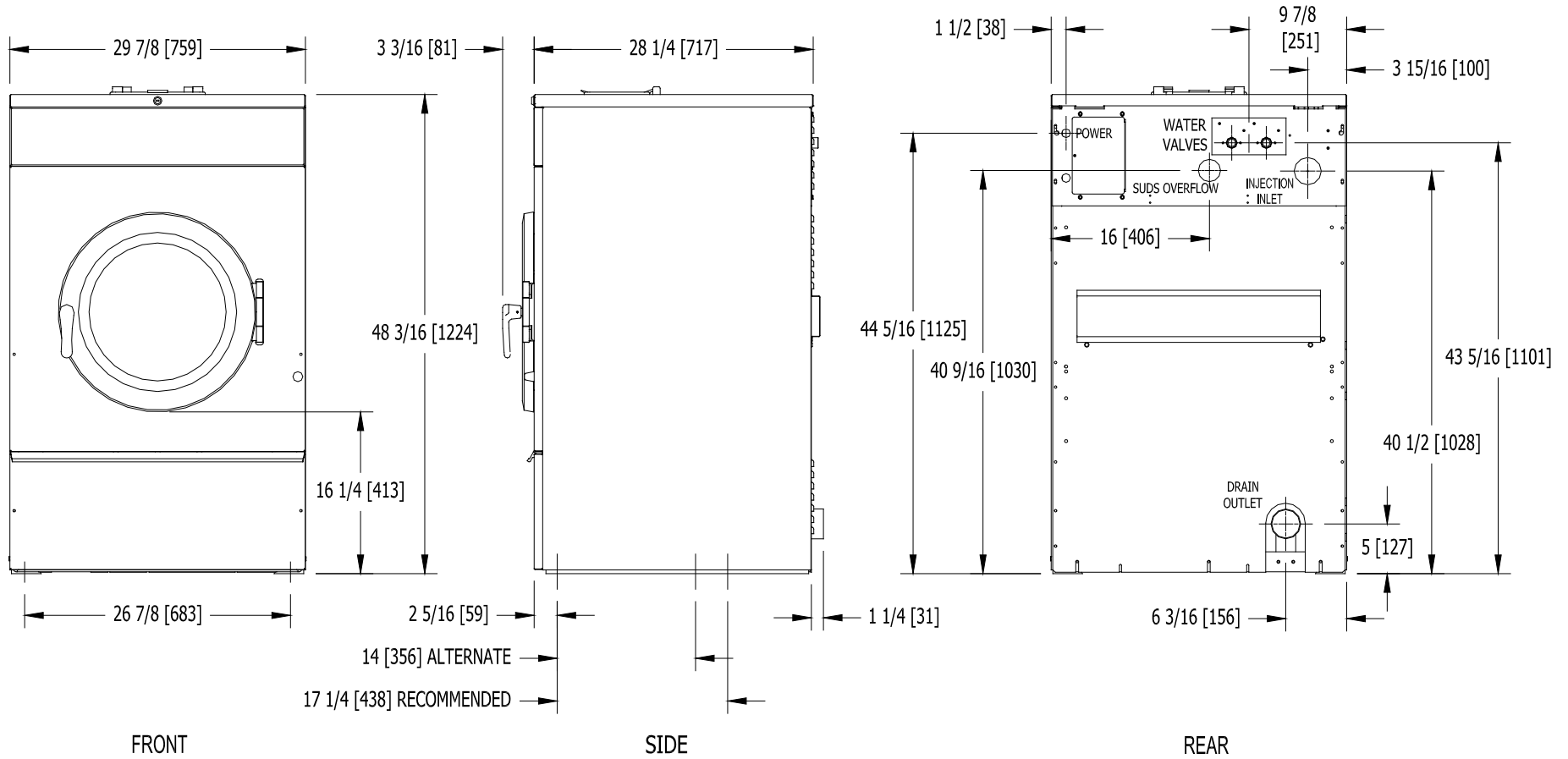

## 2.7.13 T-600 Machine Mounting Detail

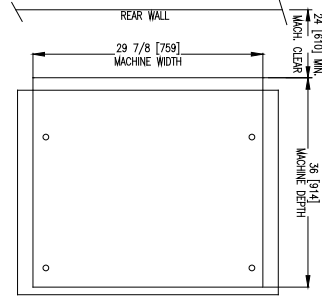
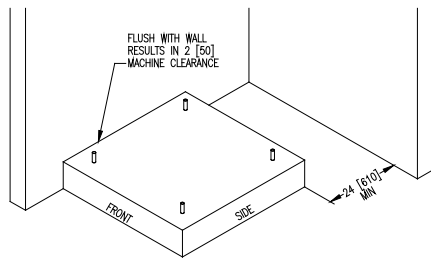

**FLOOR OUTLINE**  
Figure 1-2

5/8" X 8" GD. 8 BOLTS  
HEADED BY 4" SQ. FISH PLATE OR EQUIV.  
(1 7/8" BOLT PROTRUSION)

[ANCHORS: 16mm X 200mm GRADE 8 BOLTS  
HEADED BY 100mm SQ. FISH PLATE OR EQUIV.  
(48mm BOLT PROTRUSION)]

OR  
'HILTI' ADHESIVE ANCHORING SYSTEM.  
HILTI 'HAS' SUPER RODS 5/8 X 8 AND ADHESIVE CAPSULES  
FOR MORE INFORMATION CALL  
HILTI CUSTOMER SERVICE  
1-800-879-8000

OR  
EQUIVALENT EPOXY OR  
ACRYLIC ADHESIVE ANCHOR

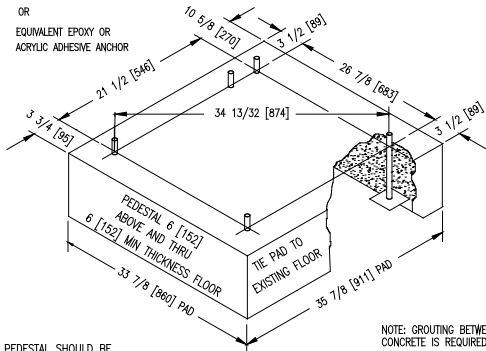

NOTE: GROUTING BETWEEN BASE AND CONCRETE IS REQUIRED.

PEDESTAL SHOULD BE  
4,000 PSI [28 MPa] MIN CONCRETE  
REINFORCED WITH  
MESH OR RODS.

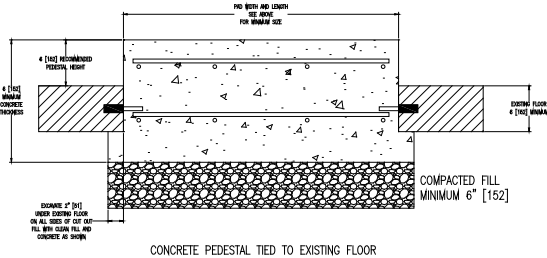

**RAISED CONCRETE PEDESTAL MOUNTING OPTION**  
Figure 1-1

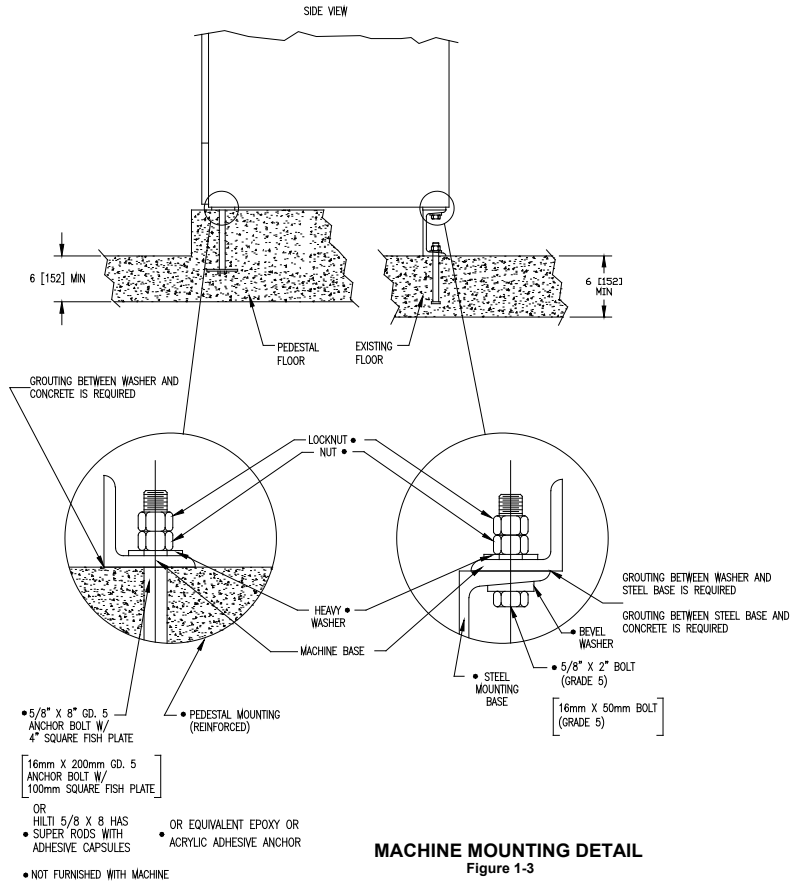

**MACHINE MOUNTING DETAIL**  
Figure 1-3

## 2.7.14 T-600 Machine Mounting Detail

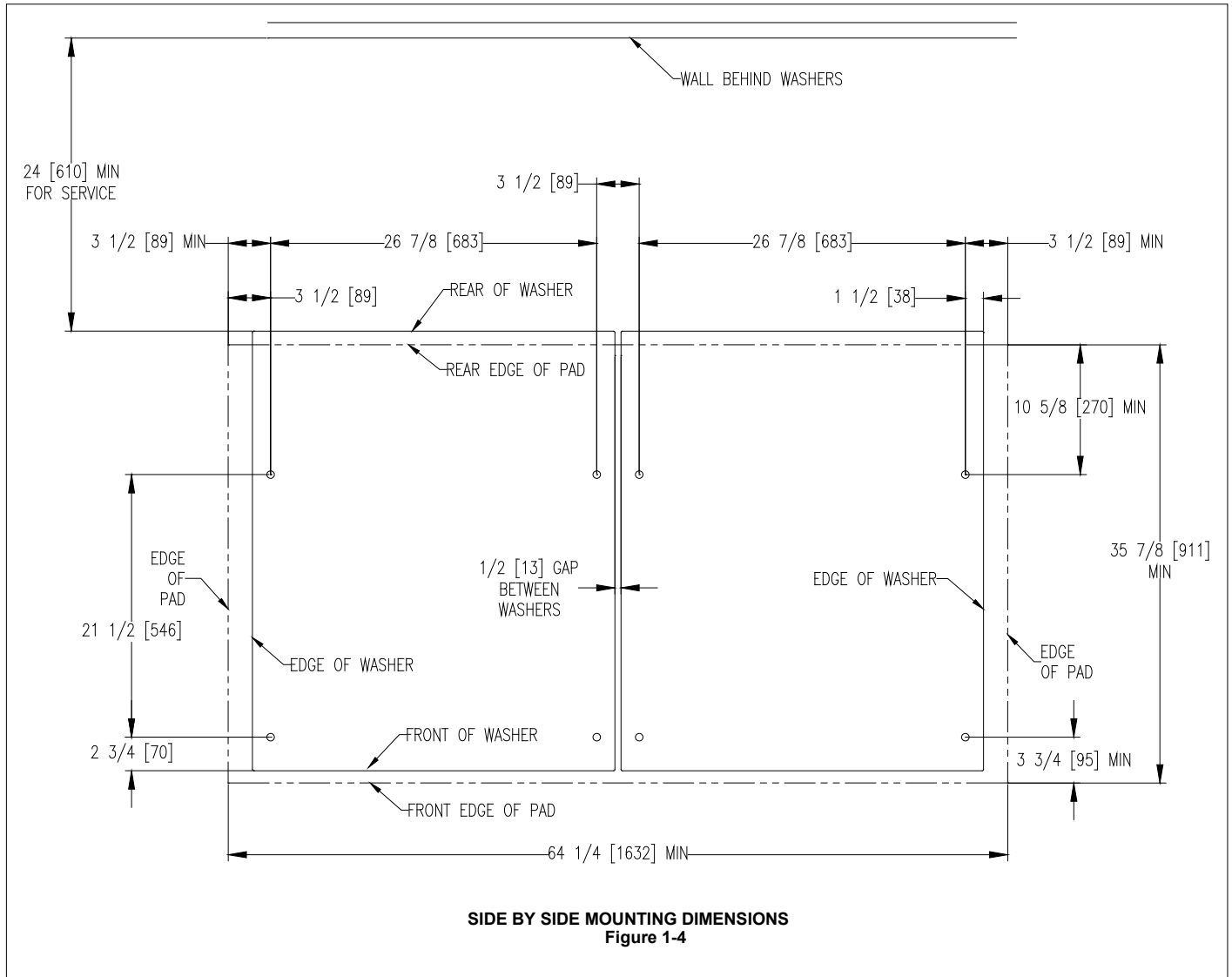

2.7.15 T-600 Industrial Washer Dimensions

T-600 INDUSTRIAL WASHER  
MOUNTING DIMENSIONS

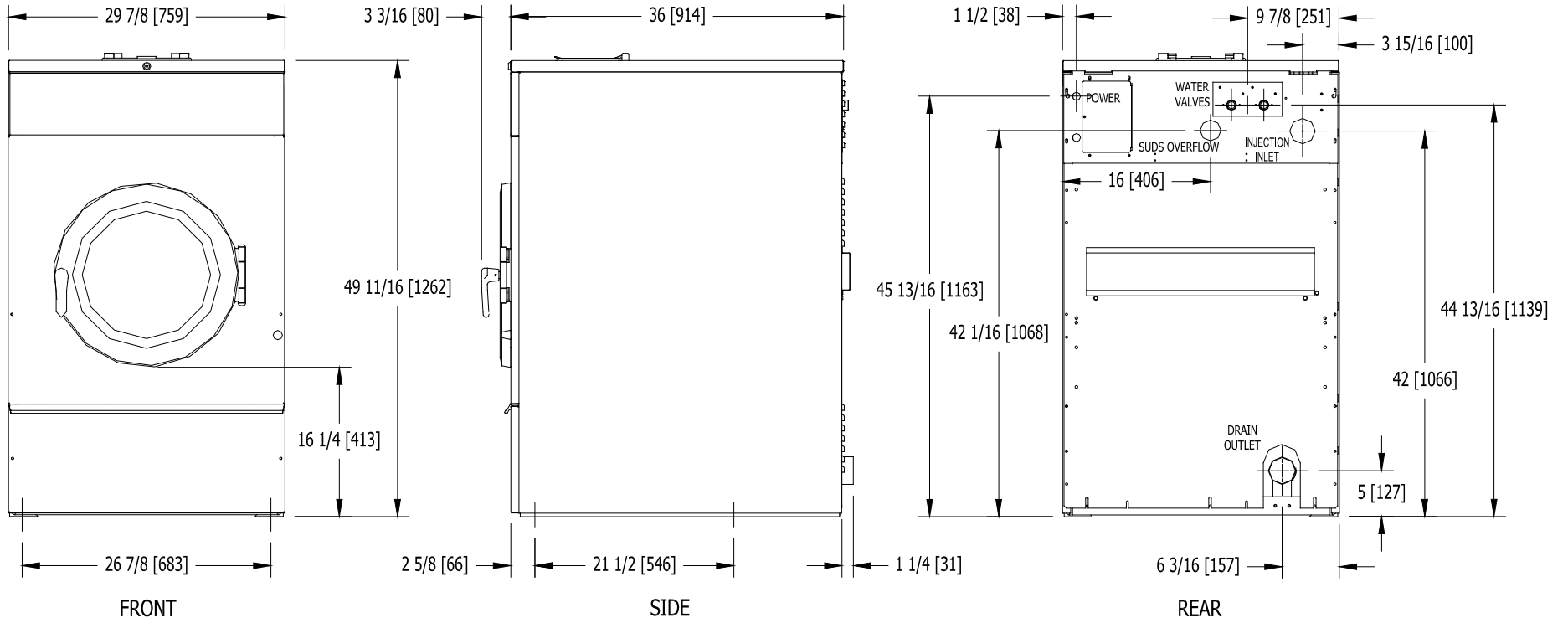



## 2.7.17 T-650 Machine Side By Side Mounting Detail

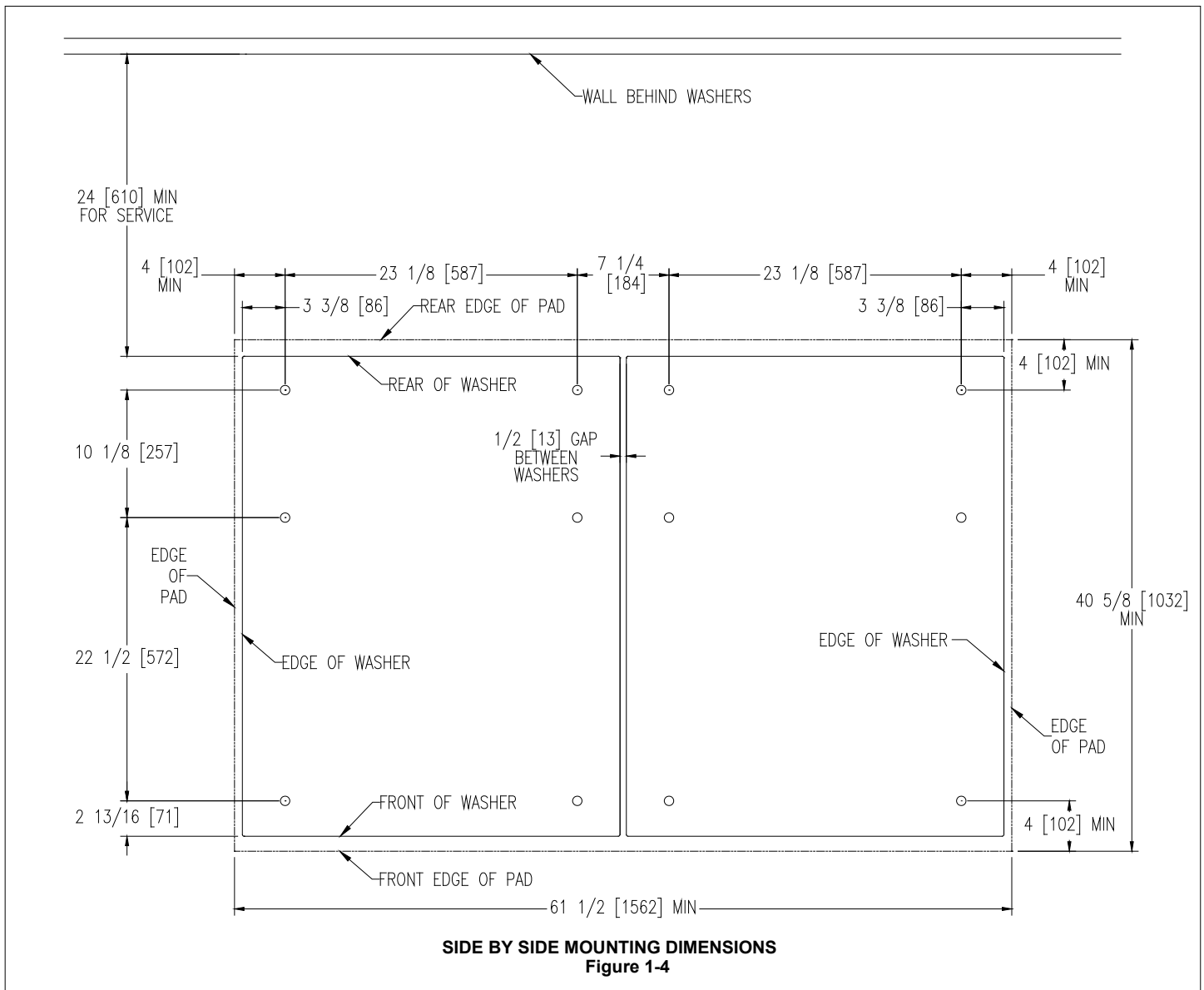

2.7.18 T-650 Industrial Washer Dimensions

T-650 INDUSTRIAL WASHER  
MOUNTING DIMENSIONS

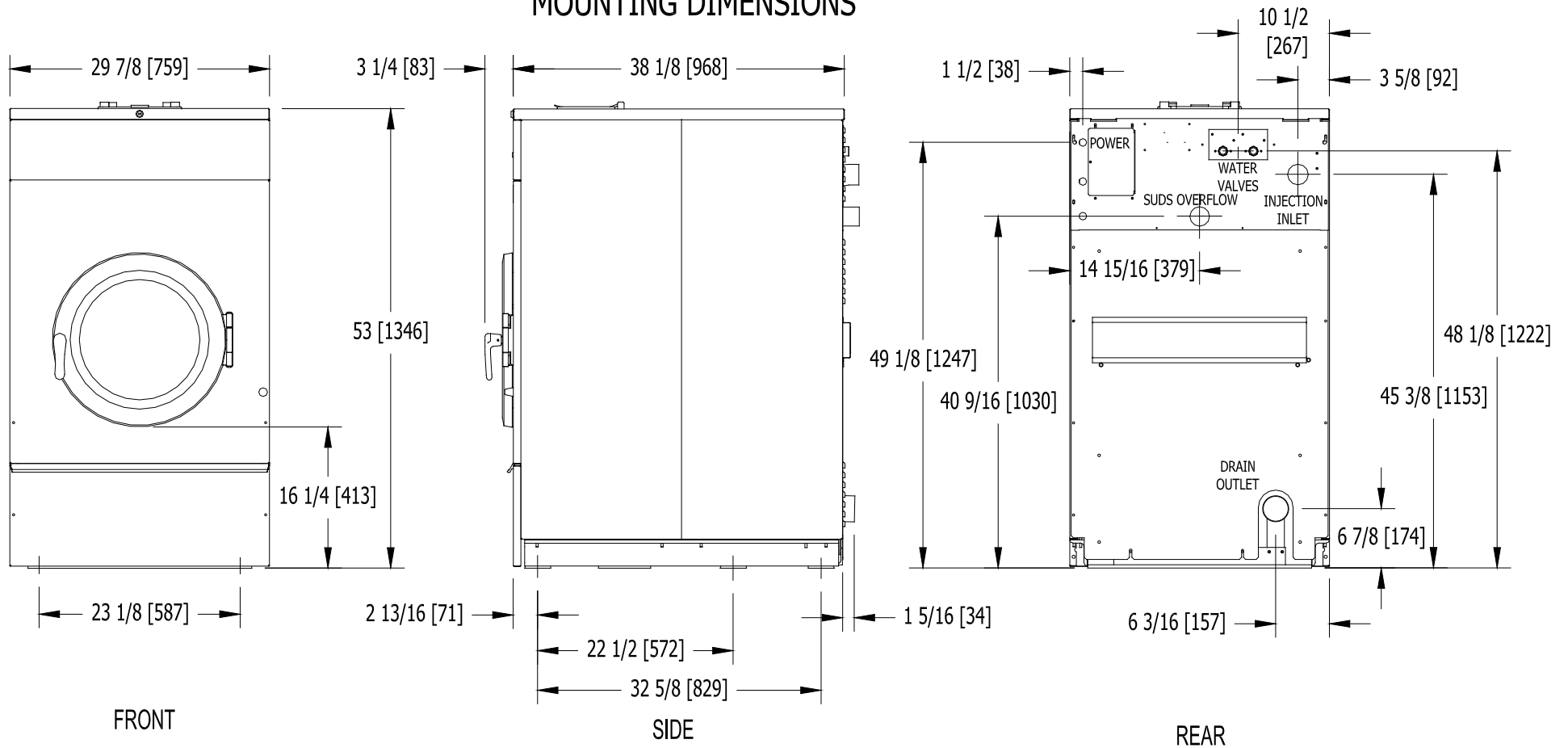

## 2.7.19 T-750 Machine Mounting Detail

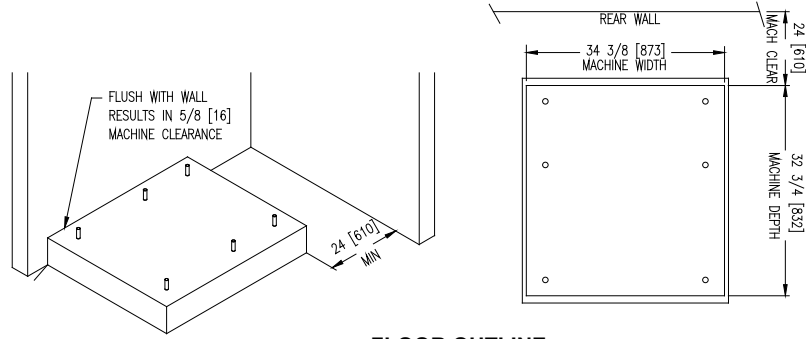

**FLOOR OUTLINE**  
Figure 1-2

3/4" X 8" GD. 8 BOLTS HEADED BY 4" SQ. FISH PLATE OR EQUIV. (2 1/2" BOLT PROTRUSION)

[ANCHORS: 19mm X 200mm GRADE 8 BOLTS HEADED BY 102mm SQ. FISH PLATE OR EQUIV. (64mm BOLT PROTRUSION)]

OR  
"HILTI" ADHESIVE ANCHORING SYSTEM.  
HILTI "HAS" SUPER RODS 3/4 X 10 AND ADHESIVE CAPSULES  
FOR MORE INFORMATION CALL  
HILTI CUSTOMER SERVICE  
1-800-879-8000

OR  
EQUIVALENT EPOXY OR  
ACRYLIC ADHESIVE ANCHOR

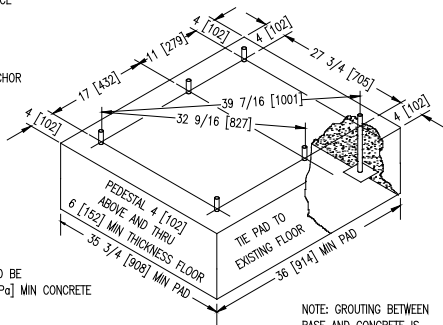

PEDESTAL SHOULD BE 4,000 PSI [28 MPa] MIN CONCRETE REINFORCED WITH MESH OR RODS.

NOTE: GROUTING BETWEEN BASE AND CONCRETE IS REQUIRED.

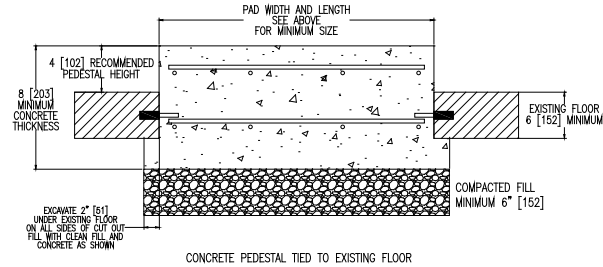

**RAISED CONCRETE PEDESTAL MOUNTING OPTION**

Figure 1-1

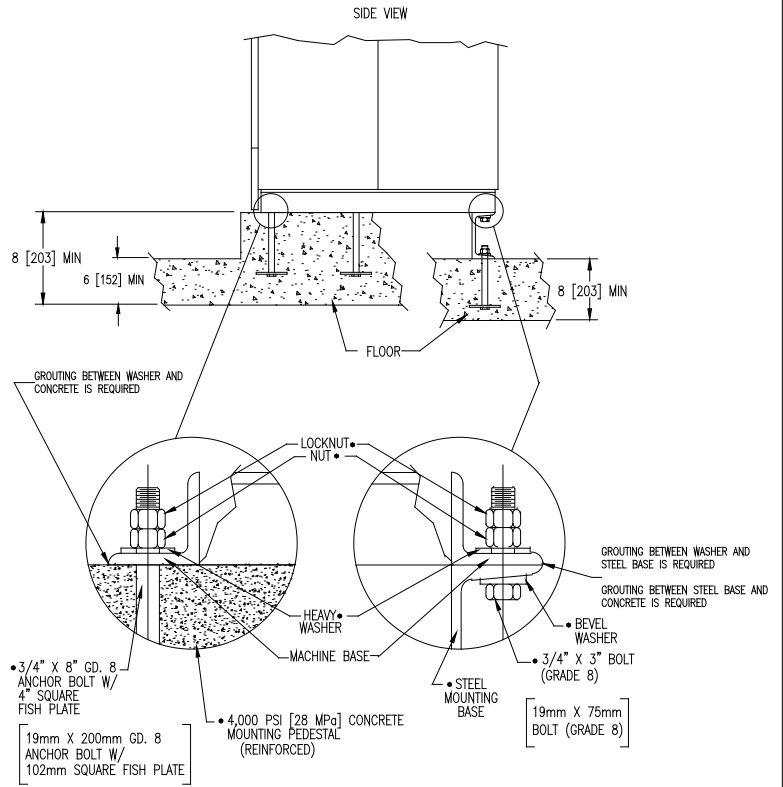

**MACHINE MOUNTING DETAIL**

Figure 1-3

OR  
• HILTI 3/4 X 10 HAS SUPER RODS WITH ADHESIVE CAPSULES  
• NOT FURNISHED WITH MACHINE

## 2.7.20 T-750 Machine Side By Side Mounting Detail

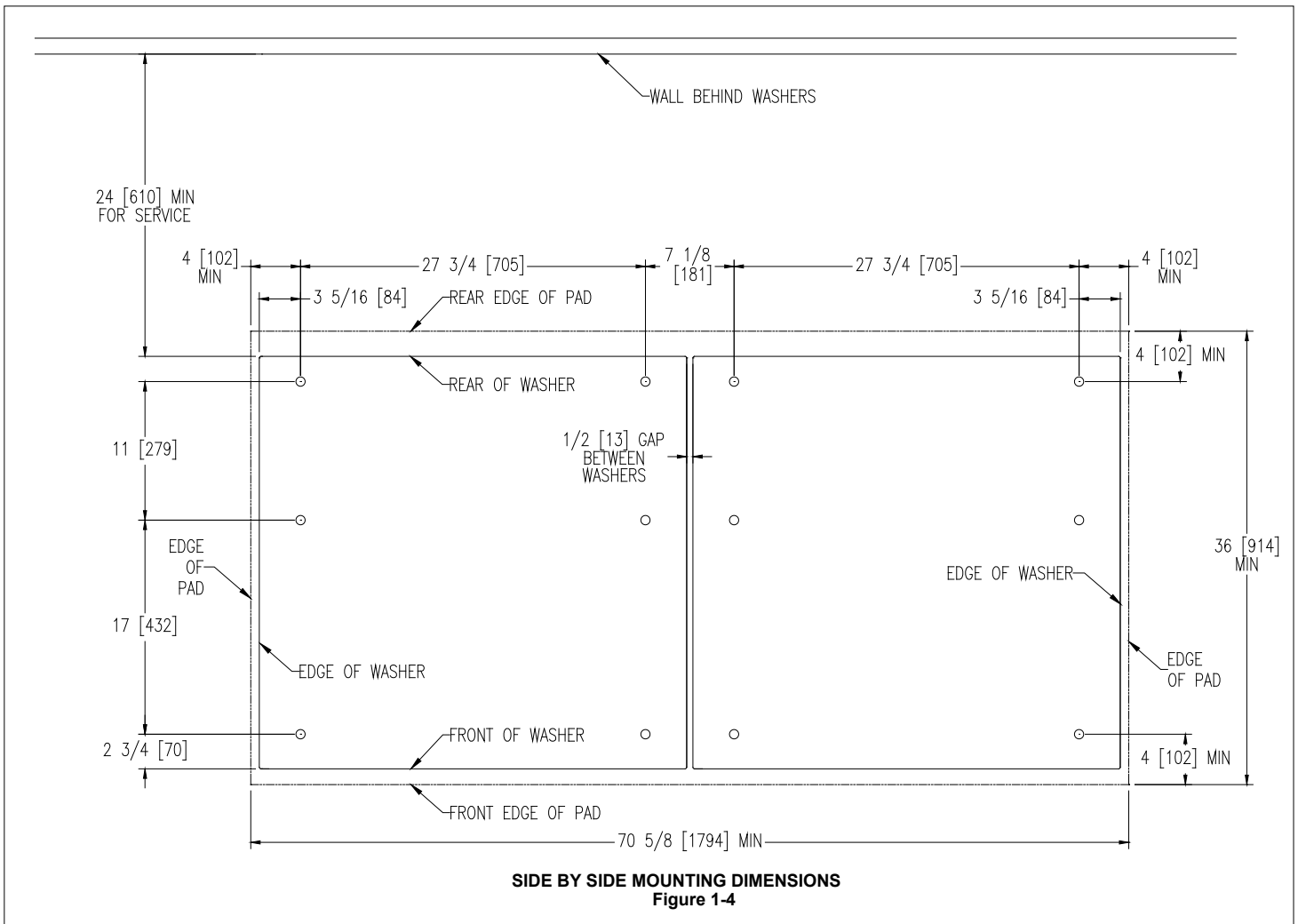

2.7.21 T-750 Industrial Washer Dimensions

T-750 INDUSTRIAL WASHER  
MOUNTING DIMENSIONS

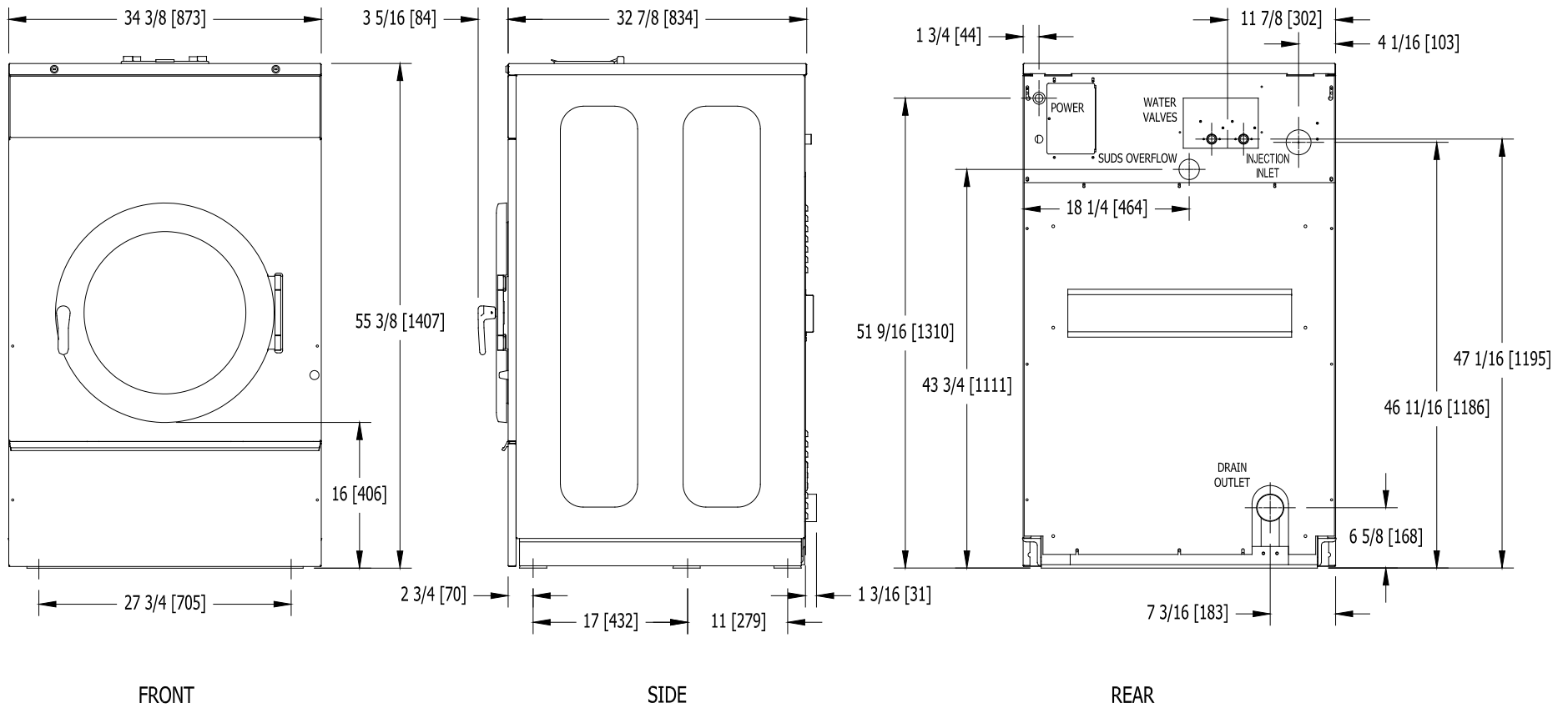

## 2.7.22 T-900/950 Machine Mounting Detail

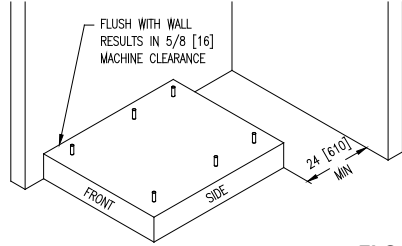

**FLOOR OUTLINE**  
Figure 1-2

3/4" X 8" GD. 8 BOLTS HEADED BY 4" SQ. FISH PLATE OR EQUIV. (2 1/2" BOLT PROTRUSION)

ANCHORS: 19mm X 200mm GRADE 8 BOLTS HEADED BY 102mm SQ. FISH PLATE OR EQUIV. (64mm BOLT PROTRUSION)

OR

"HILTI" ADHESIVE ANCHORING SYSTEM.  
HILTI "HAS" SUPER RODS 3/4 X 10 AND ADHESIVE CAPSULES  
FOR MORE INFORMATION CALL  
HILTI CUSTOMER SERVICE  
1-800-879-8000

OR

EQUIVALENT EPOXY OR ACRYLIC ADHESIVE ANCHOR

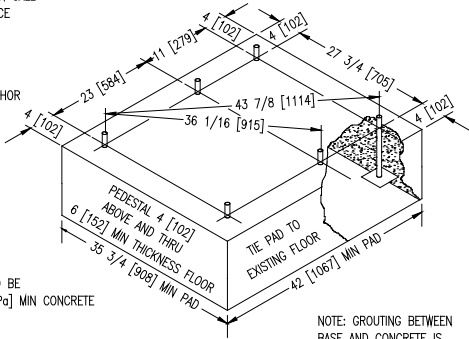

PEDESTAL SHOULD BE 4,000 PSI [28 MPa] MIN CONCRETE REINFORCED WITH MESH OR RODS.

NOTE: GROUTING BETWEEN BASE AND CONCRETE IS REQUIRED.

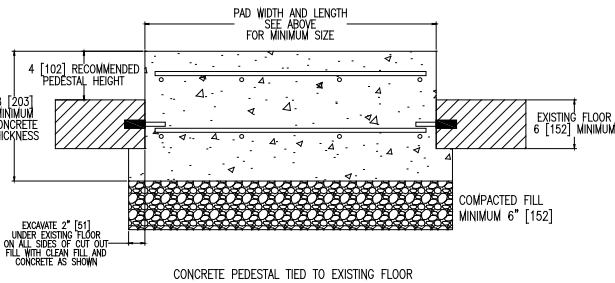

**RAISED CONCRETE PEDESTAL MOUNTING OPTION**  
Figure 1-1

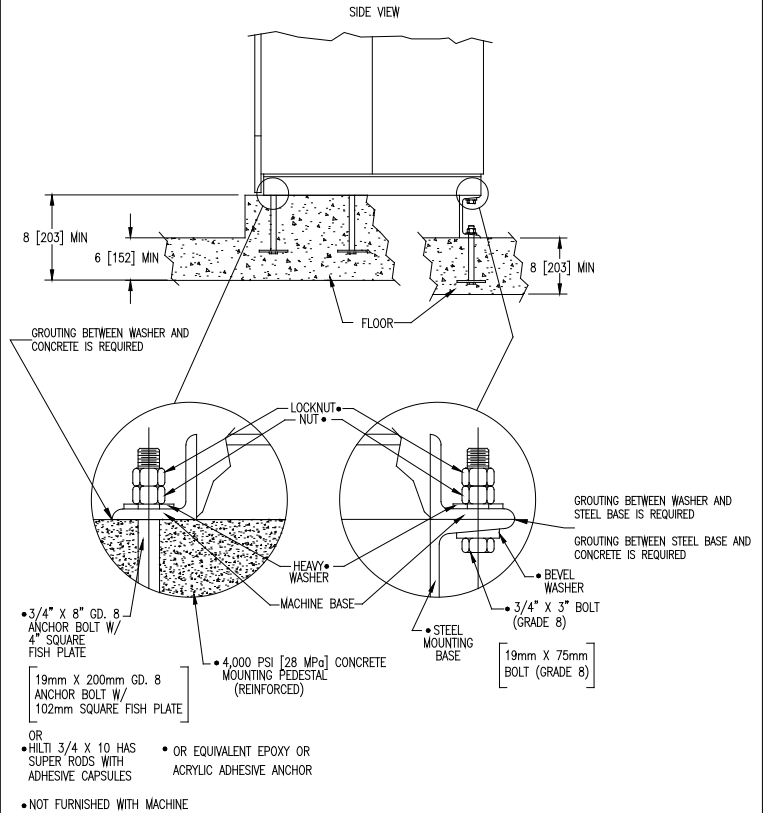
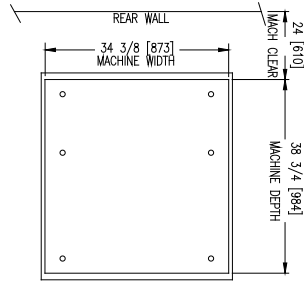

OR

"HILTI" 3/4 X 10 HAS SUPER RODS WITH ADHESIVE CAPSULES

OR EQUIVALENT EPOXY OR ACRYLIC ADHESIVE ANCHOR

NOT FURNISHED WITH MACHINE

**MACHINE MOUNTING DETAIL**  
Figure 1-3

### 2.7.23 T-900/950 Machine Side By Side Mounting Detail

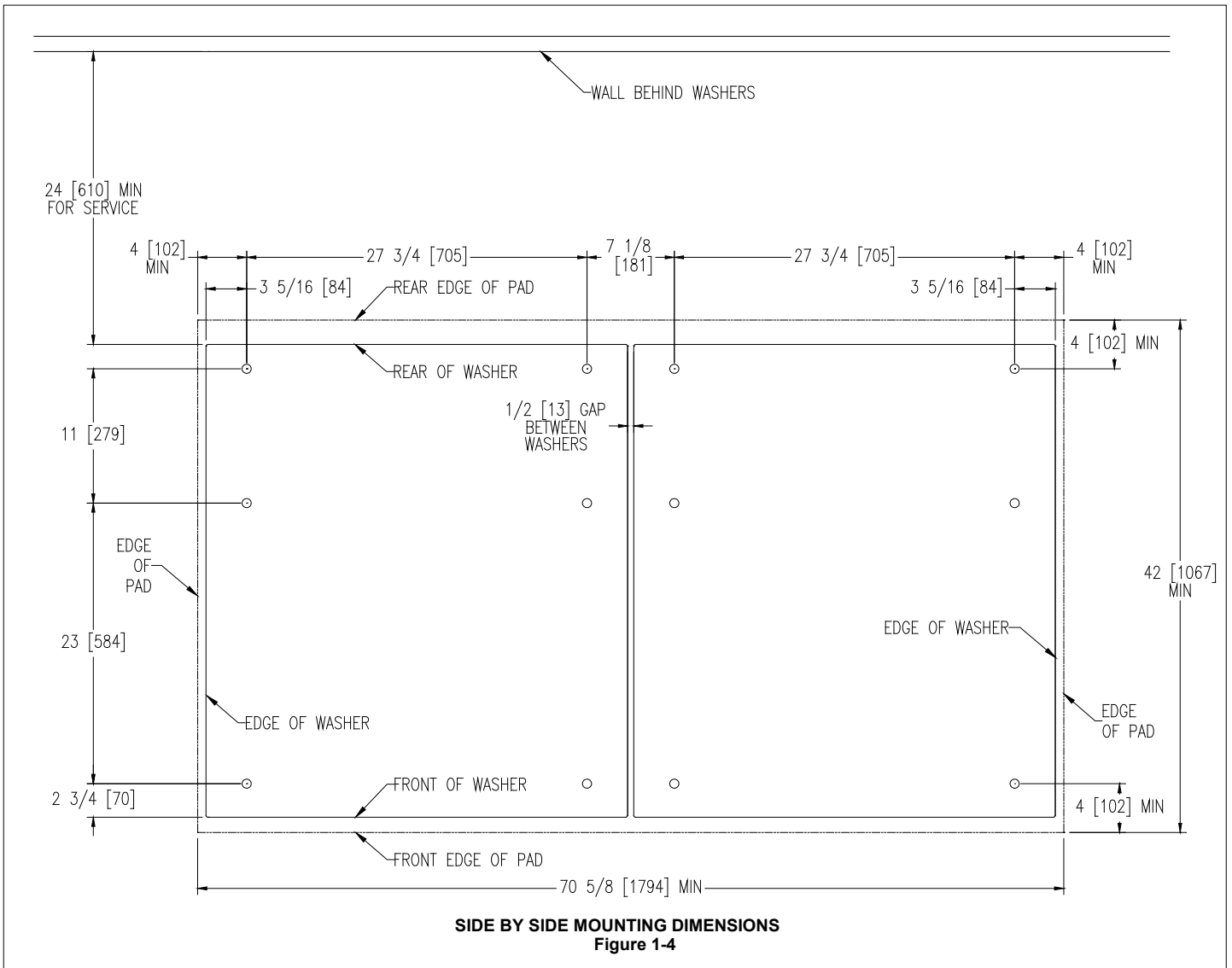

2.7.24 T-900/950 Industrial Washer Dimensions

T-900 / 950 INDUSTRIAL WASHER  
MOUNTING DIMENSIONS

\*\*TOP WATER VALVES ONLY ON T-950

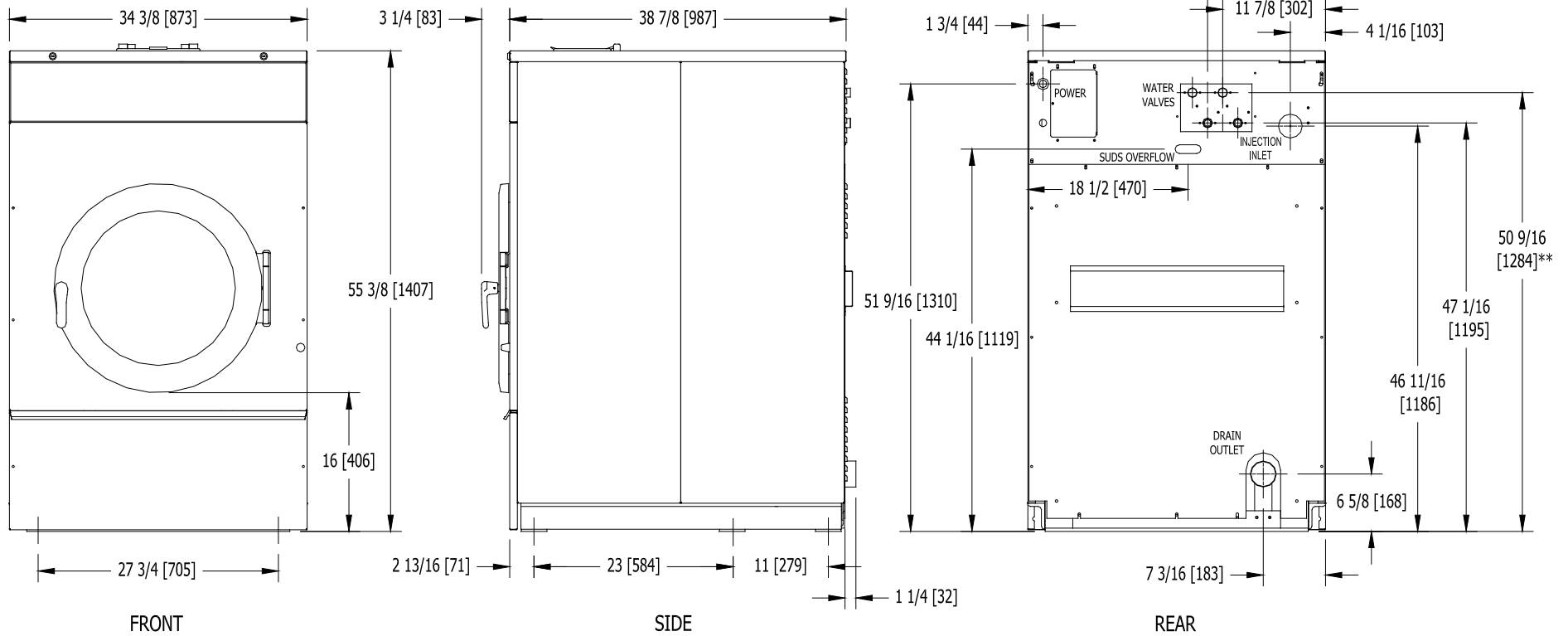



## 2.7.26 T-1200 Machine Side By Side Mounting Detail

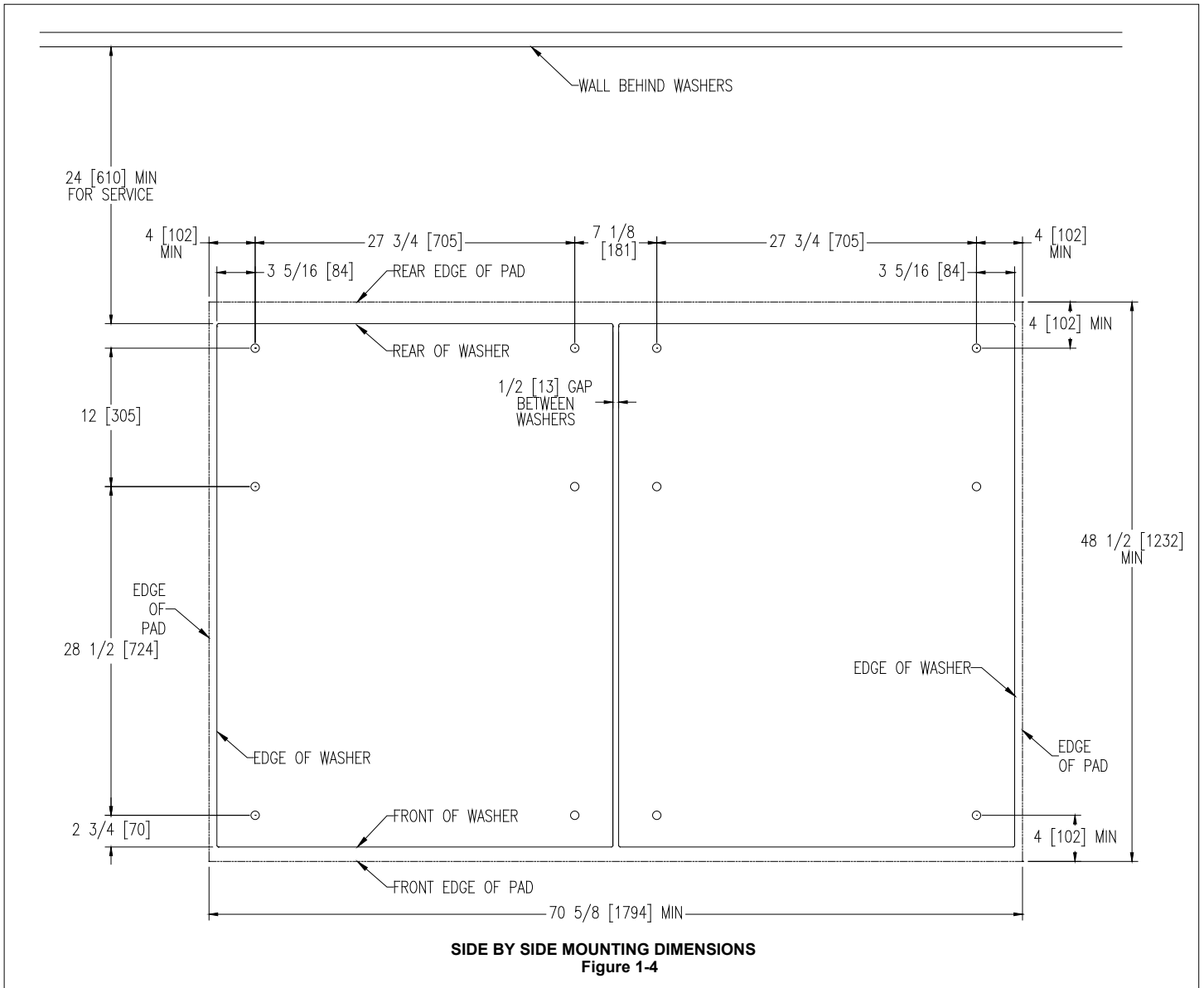

2.7.27 T-1200 Industrial Washer Dimensions

T-1200 INDUSTRIAL WASHER  
MOUNTING DIMENSIONS

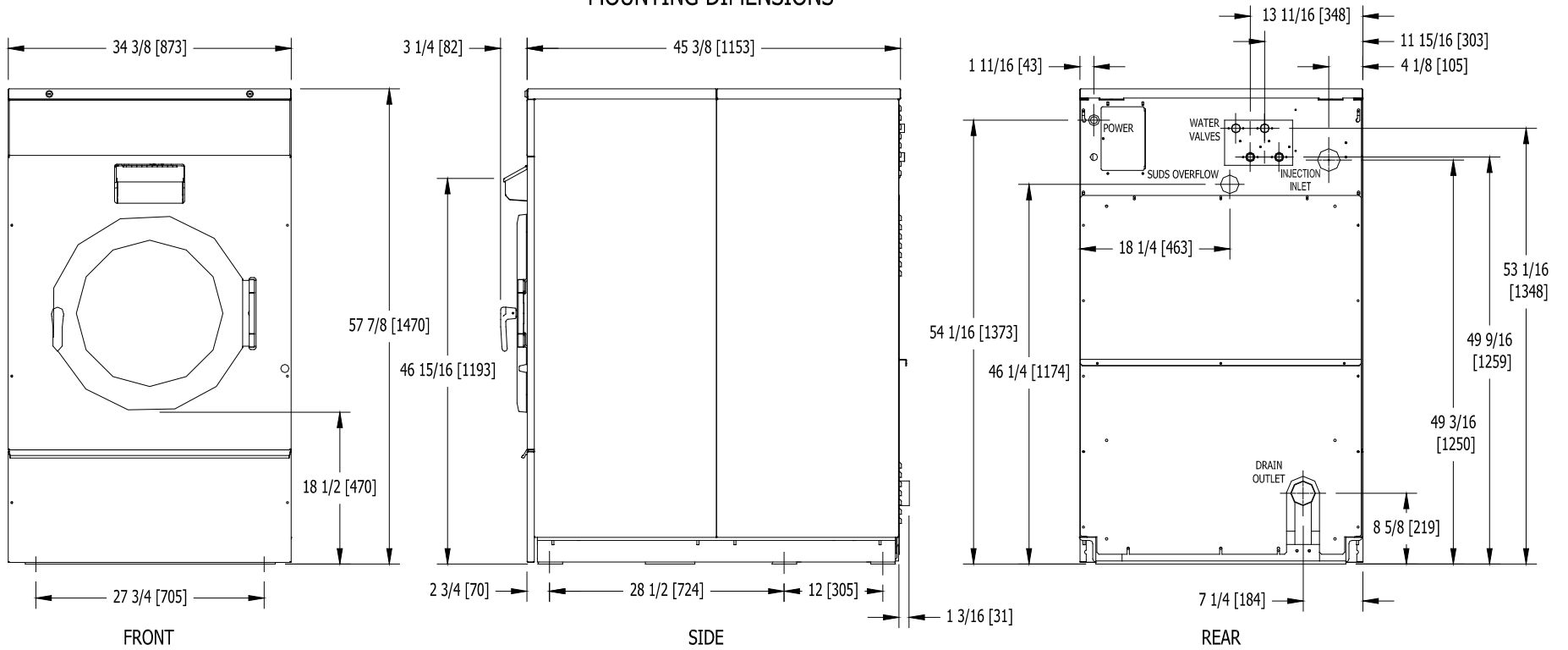

# T-1450 Machine Mounting Detail

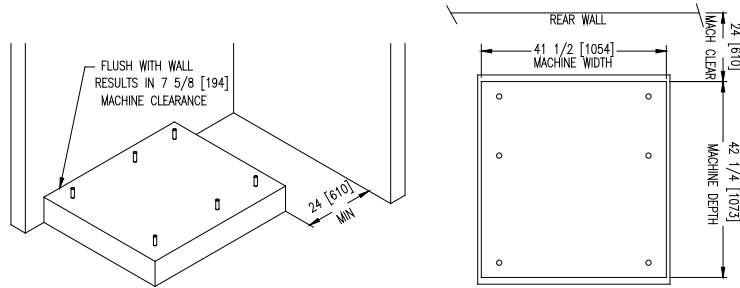

**FLOOR OUTLINE**  
Figure 1-2

3/4" X 8" GD. 8 BOLTS HEADED BY 4" SQ. FISH PLATE OR EQUIV. (2 1/2" BOLT PROTRUSION)

OR

'HILTI' ADHESIVE ANCHORING SYSTEM. HILTI 'HAS' SUPER RODS 3/4 X 10 AND ADHESIVE CAPSULES FOR MORE INFORMATION CALL HILTI CUSTOMER SERVICE 1-800-879-8000

OR

EQUIVALENT EPOXY OR ACRYLIC ADHESIVE ANCHOR

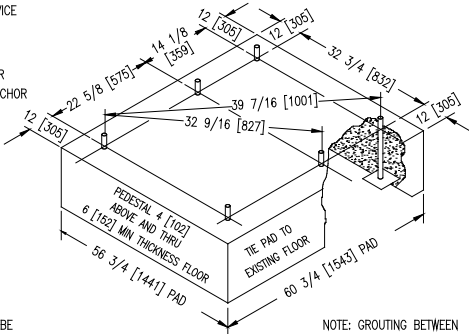

PEDESTAL SHOULD BE 4,000 PSI [28 MPa] MIN CONCRETE REINFORCED WITH MESH OR RODS.

NOTE: GROUTING BETWEEN BASE AND CONCRETE IS REQUIRED.

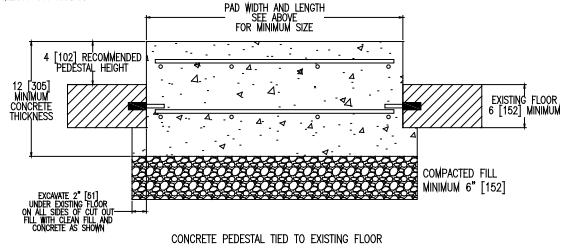

**RAISED CONCRETE PEDESTAL MOUNTING OPTION**  
Figure 1-1

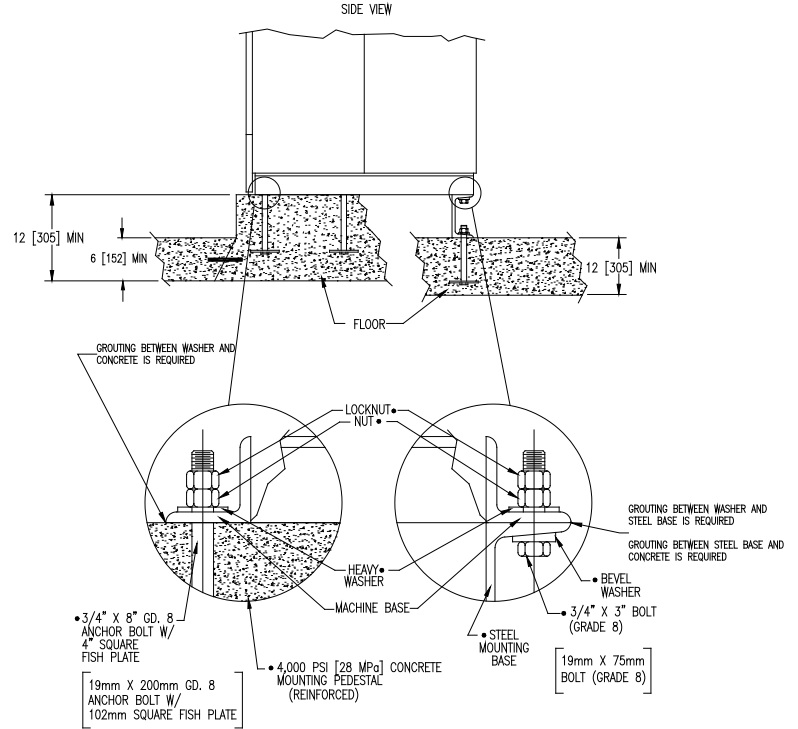

OR

'HILTI' 3/4 X 10 HAS SUPER RODS WITH ADHESIVE CAPSULES

• NOT FURNISHED WITH MACHINE

**MACHINE MOUNTING DETAIL**  
Figure 1-3

## 2.7.28 T-1450 Machine Side By Side Mounting Detail

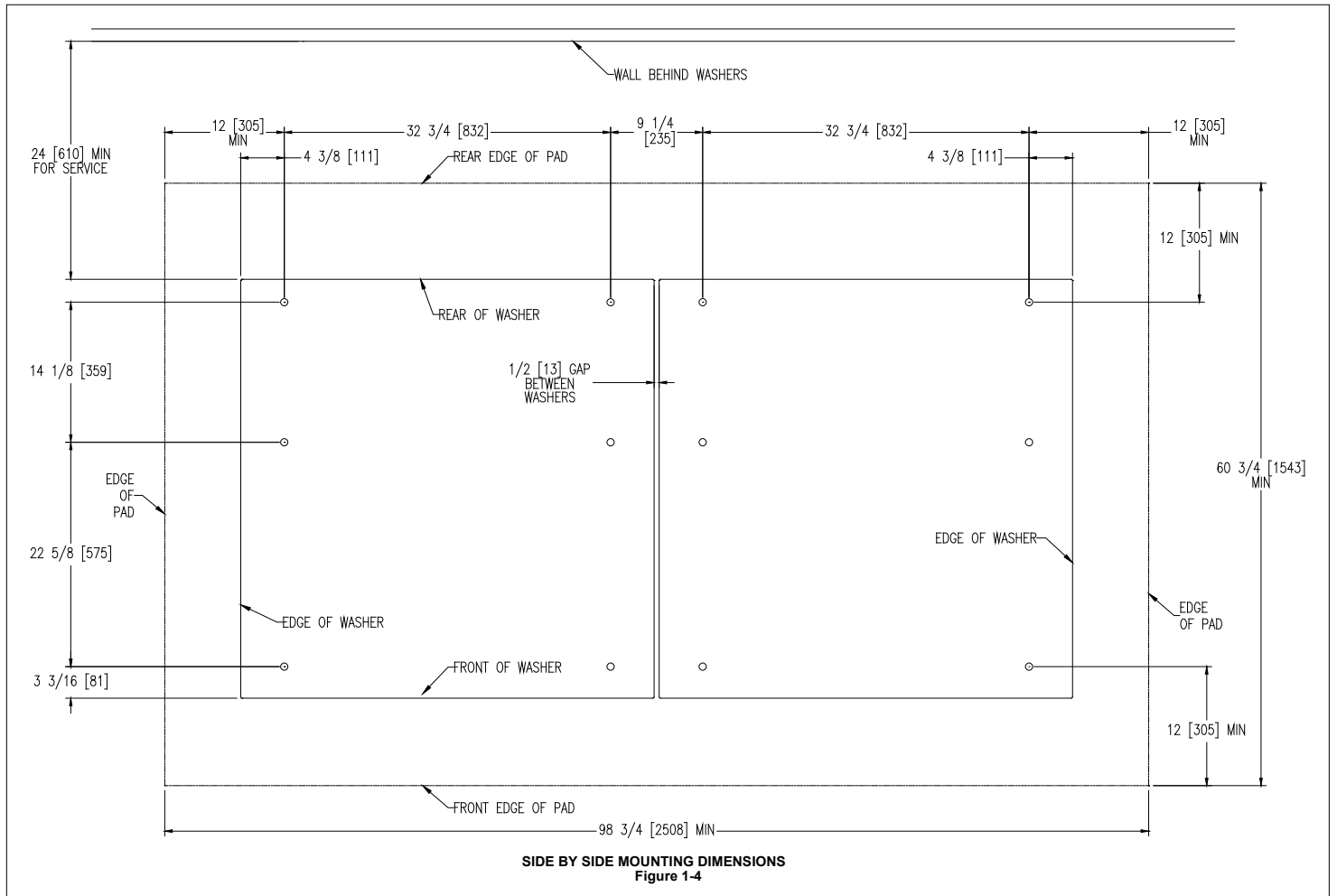

2.7.29 T-1450 Industrial Washer Dimensions

T-1450 INDUSTRIAL WASHER  
MOUNTING DIMENSIONS

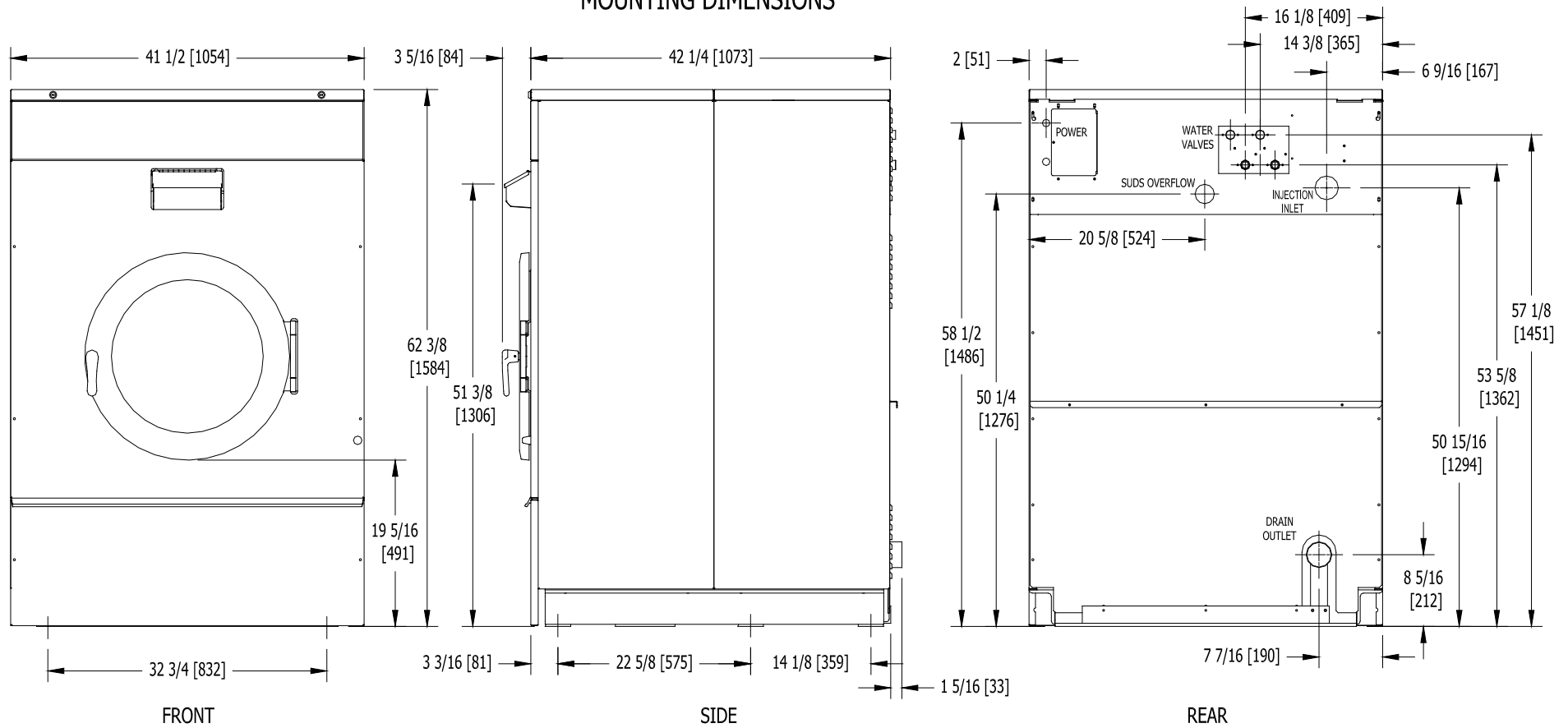

## 2.7.30 T-1800 Machine Mounting Detail

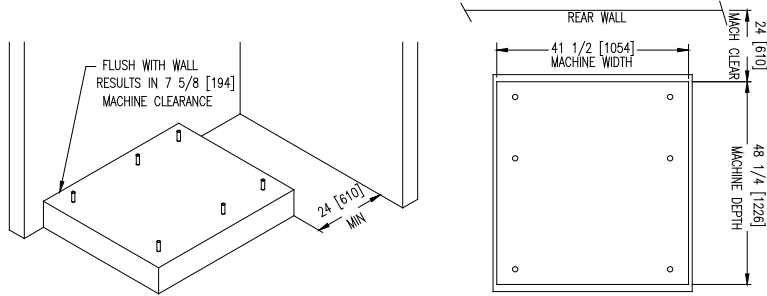

**FLOOR OUTLINE**

Figure 1-2

3/4" X 8" GD. 8 BOLTS HEADED BY 4" SQ. FISH PLATE OR EQUIV. (2 1/2" BOLT PROTRUSION)

ANCHORS: 19mm X 200mm GRADE 8 BOLTS HEADED BY 102mm SQ. FISH PLATE OR EQUIV. (64mm BOLT PROTRUSION)

OR

'HILTI' ADHESIVE ANCHORING SYSTEM.

HILTI 'HAS' SUPER RODS 3/4 X 10 AND ADHESIVE CAPSULES

FOR MORE INFORMATION CALL HILTI CUSTOMER SERVICE 1-800-879-8000

OR

EQUIVALENT EPOXY OR ACRYLIC ADHESIVE ANCHOR

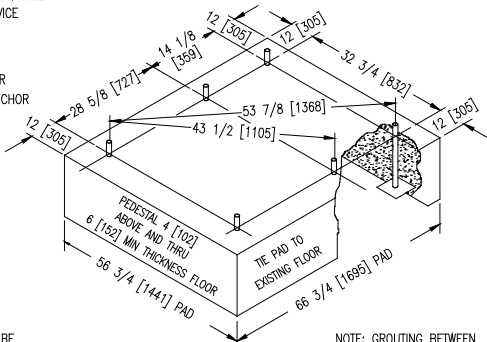

PEDESTAL SHOULD BE 4,000 PSI [28 MPa] MIN CONCRETE REINFORCED WITH MESH OR RODS.

NOTE: GROUTING BETWEEN BASE AND CONCRETE IS REQUIRED.

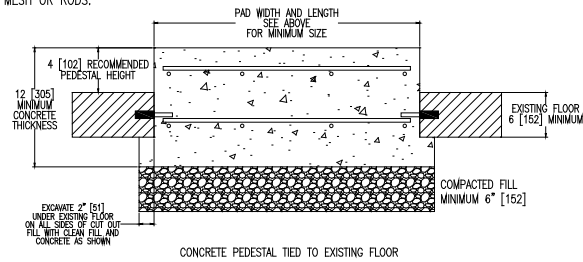

**RAISED CONCRETE PEDESTAL MOUNTING OPTION**

Figure 1-1

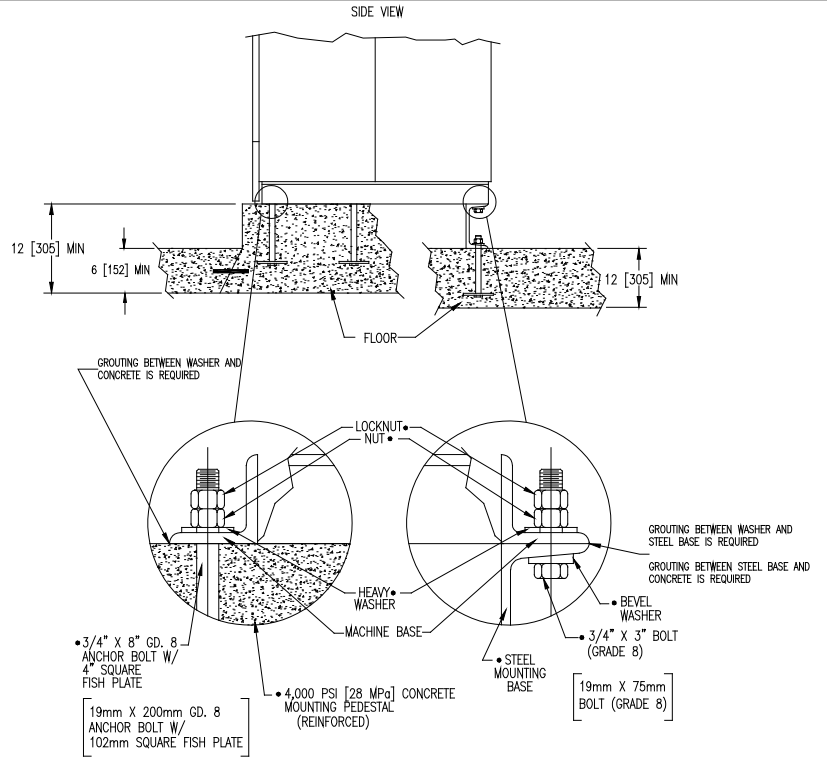

OR

'HILTI' 3/4 X 10 HAS SUPER RODS WITH ADHESIVE CAPSULES

• NOT FURNISHED WITH MACHINE

**MACHINE MOUNTING DETAIL**

Figure 1-3

## 2.7.31 T-1800 Machine Side By Side Mounting Detail

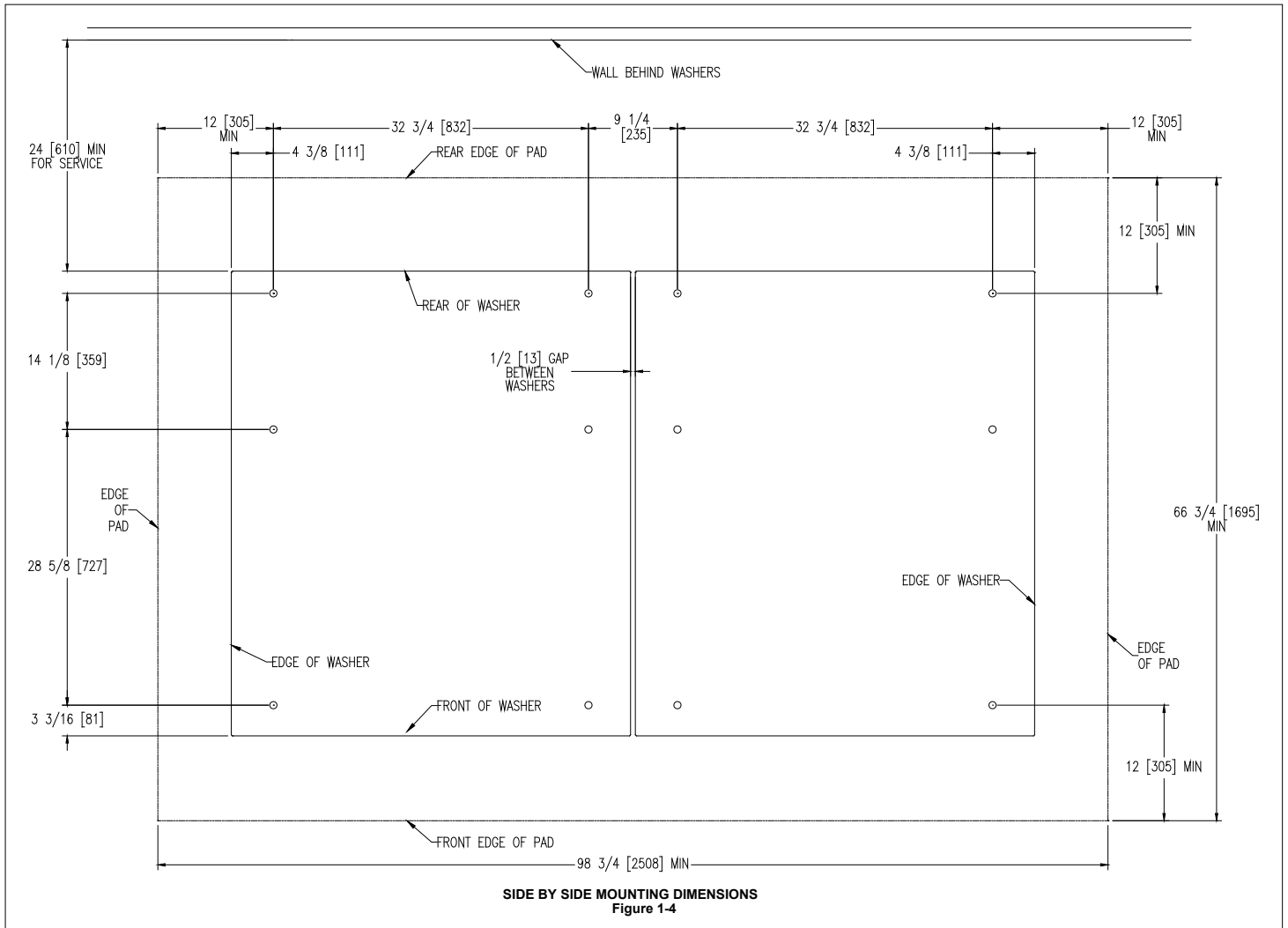

## 2.7.32 T-1800 Industrial Washer Dimensions

### T-1800 OPL WASHER MOUNTING DIMENSIONS

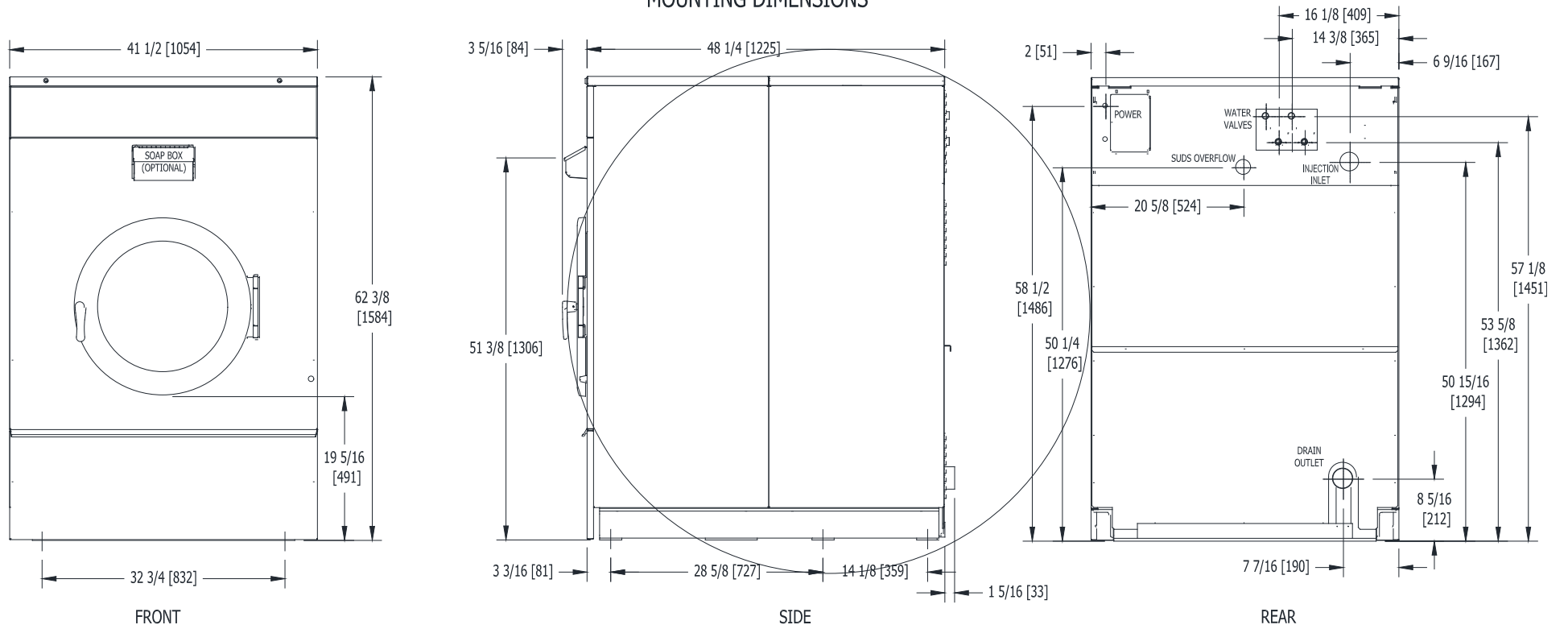

## 2.8 PLUMBING

Water supply hoses are provided with each machine. The threaded connections on the hoses are  $\frac{3}{4}$ -11  $\frac{1}{2}$  NHT for 60 Hz models and  $\frac{3}{4}$ -14 BSP for 50 Hz models.

Separate hot and cold water lines must be supplied to the machine, maintaining 30 psi to 120 psi (207 kPa to 827 kPa) water flow pressure. A 140°F (60°C) hot water supply is recommended for best washing results. Do not exceed 180°F (82°C) water temperature.

## 2.9 DRAIN

The drain outlet tube size:

For T-300 and 350 is 2  $\frac{1}{4}$  inches (57 mm) in diameter, and for all other models is 3 inches (76 mm) in diameter.

Any drain hose used must be lower than the drain valve to assure proper draining.

## 2.10 PROTECTIVE FILM

The machine may have protective adhesive film on the front control panel label area and on the front, top, and side stainless steel panels. The film may be peeled off before putting the machine into service.

## 2.11 ELECTRICAL

The Dexter single/three-phase 208-240VAC 60 Hz (single phase 230VAC 50 Hz) washing machines are intended to be permanently installed appliances. No power cord is provided. The machine should be connected to an individual branch circuit not shared by lighting or other equipment. The connection should be sheathed in liquid-tight or approved flexible conduit, or equivalent, with conductors of the proper size and insulation (50 Hz: A means for disconnection with a contact separation of at least 3 mm must be provided. The sheath of the supply cord must be at least equivalent to that of a cord complying with IEC 227 or IEC 245). A qualified technician should make such connections in accordance with the wiring diagram. See specification sheet for minimum recommended wire size.

Individual circuit breakers for each unit are required. Do not use ground-fault (earth-fault) circuit breakers or ground-fault (earth-fault) circuit interrupter outlets.

**WARNING:**  
**SHUT OFF POWER AND WATER BEFORE OPENING ANY SERVICE  
 PANELS.**

200–250 VAC  
 POWER  
 CONNECTIONS

L1

--

L2

--



L3

--

N

--



	
---	---

120 VAC (60HZ)  
 OR 24 VAC (50HZ)  
 INJECTOR  
 SUPPLY  
 SIGNALS

A

--

B

--

C

--

D

--

COM

--

**ELECTRICAL CONNECTIONS**

### *2.11.1 INSTALLING THE ELECTRICAL CONNECTION*

- 2.11.1.1 Disconnect all power to the washer.
- 2.11.1.2 Remove the top panel of the washer and locate the power terminal block near the back of the control compartment.
- 2.11.1.3 If power is 208-240V-**3PH**-60Hz, connect L1, L2, L3 and Ground. If there is a high leg, it must NOT be connected to L1 or L2. However, failure due to a voltage surge on the high leg is not covered by equipment warranty. Contact Dexter Laundry with any questions.
- 2.11.1.4 If power is 208-240V-**1PH**-60Hz, connect L1, L2 and Ground.
- 2.11.1.5 If power is 230V-**1PH**-50Hz, connect L1, N and Earth.

NOTE: It is important that the grounding screw next to the power terminal block be connected to a good external ground.

### *2.11.2 FUSING REQUIREMENTS*

Single- and Three -phase models:

See specification sheet for required TIME-DELAY (DUAL ELEMENT) FUSE size (or equivalent circuit breaker)

### 2.11.3 CONTROLS TRANSFORMER (208-240V 60 Hz models only)

The controls transformer is located inside the control trough and steps a range of 208 to 240 volts down to 115 volts. There are two terminals on the controls transformer for the primary (incoming) power. Use the terminal marked "208V" for power supplies between 208 and 219 volts. Use the terminal marked "240V" for power supplies between 220 and 240 volts. Refer to the following for control transformer connections.

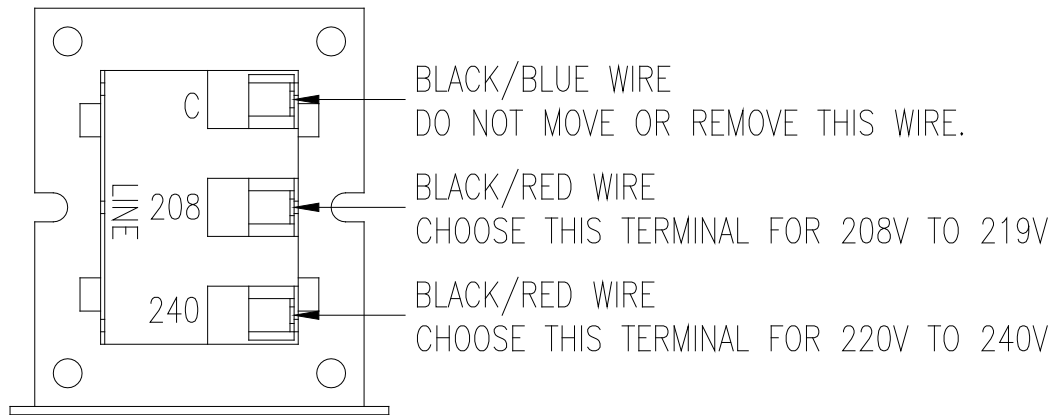

### 60 Hz Control Transformer Connections

### 2.11.4 CONTROLS TRANSFORMER (230V 50 Hz models only)

The controls transformer is located inside the control trough and steps a range of 180 to 255 volts down to 24 volts. There are two terminals on the controls transformer for the primary (incoming) power. Use the terminal marked "L1 200V" for power supplies between 180 and 229 volts. Use the terminal marked "L1 230V" for power supplies between 230 and 255 volts.

### CONTROL TRANSFORMER CONNECTIONS

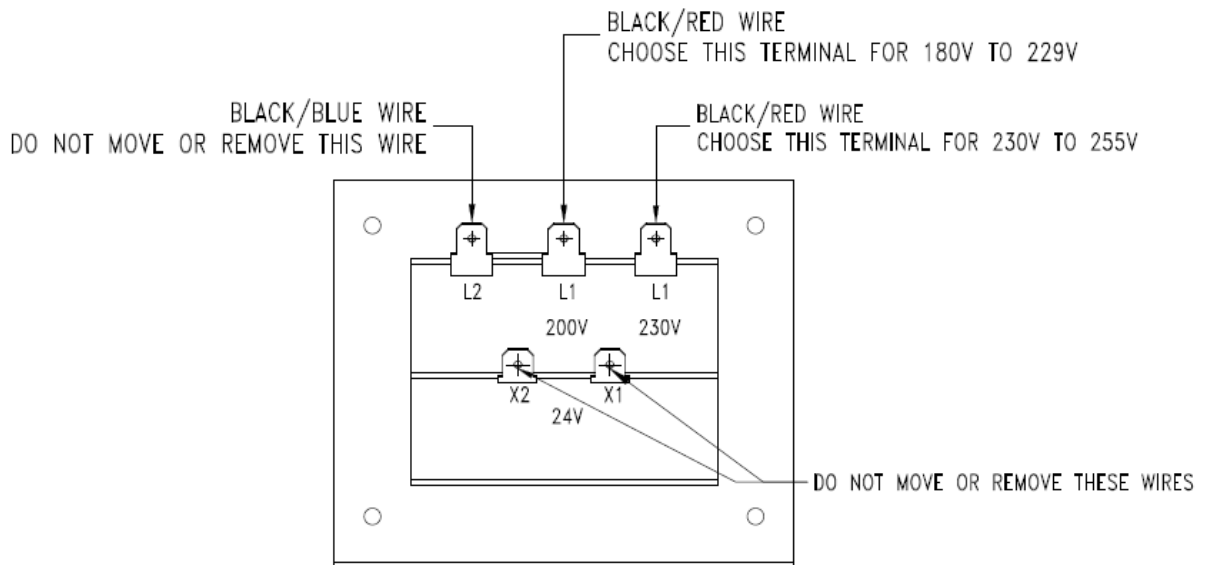

### 50 Hz Control Transformer Connections

**2.11.5 MAXIMUM SPIN SPEED ADJUSTMENT (All washers except T-950)**

If desired, the washer can be adjusted to limit the maximum extract spin speed for all wash cycles.

To make this adjustment, a jumper wire must either be installed or removed on the Variable Frequency Drive (VFD), depending on the washer model and desired speed. This Dexter jumper part number 8220-057-036 (qty 1) is factory supplied on terminal points "10V" and "RC". Remove this jumper to make new jumper connections if necessary. Refer to figure below for the approximate location of the control terminations on the Variable Frequency Drive (VFD) and for appropriate jumper connection points indicated with an "X" for the desired maximum spin speed setting. If no adjustment to the default spin speed is desired, do not remove or add any wires on VFD.

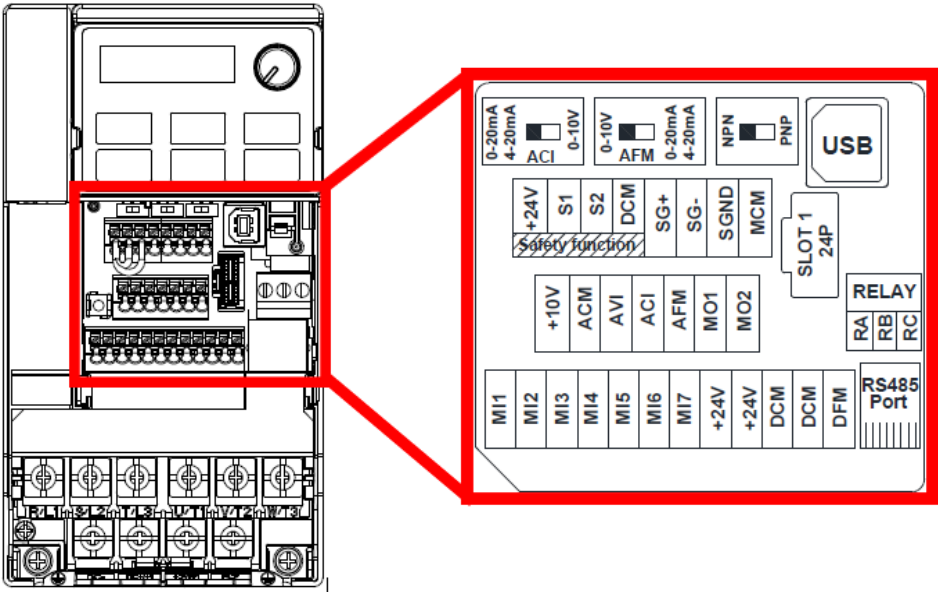

**Control Terminations on Variable Frequency Drive**

V Series Washer Model	Max Spin Speed	Jumper Terminal Locations on Variable Frequency Drive (VFD)													
		MI1	MI2	MI3	MI4	MI5	MI6	DCM (Left)	DCM (Right)	24V	ACM	AVI	ACI	10V	MO1
T-300, T-400, T-600, T-900, T-1200	60 G											X		X	
	80 G				X			X							
	100 G	Default Setting (No Jumper Required)													
T-350, T-450, T-750	60 G											X		X	
	100 G				X			X							
	140 G					X		X							
	200 G	Default Setting (No Jumper Required)													
T-650, T-1450	100 G											X		X	
	140 G	REMOVE Brown Jumper Between MI5/MO1													
	200 G	Default Setting (No Jumper Required)													
T-1800	100 G											X		X	
	80 G	REMOVE Brown Jumper Between MI5/MO1													
	140 G	Default Setting (No Jumper Required)													

**Spin Speed Adjustment Jumper Locations**

### 2.11.6 MAXIMUM SPIN SPEED ADJUSTMENT (T-950 Only)

The variable frequency drive allows for varying acceleration during Final Spin on T-950 models. It is important to utilize a decreased acceleration rate when the application power is low. This acceleration rate is determined by a white wire jumper installed on the drive terminal block from +10V to AVI.

Remove the wire jumper when input power is between 208 and 219 volts. Keep the jumper installed when input power is between 220 and 240 volts. Reference the drawing below for the jumper location.

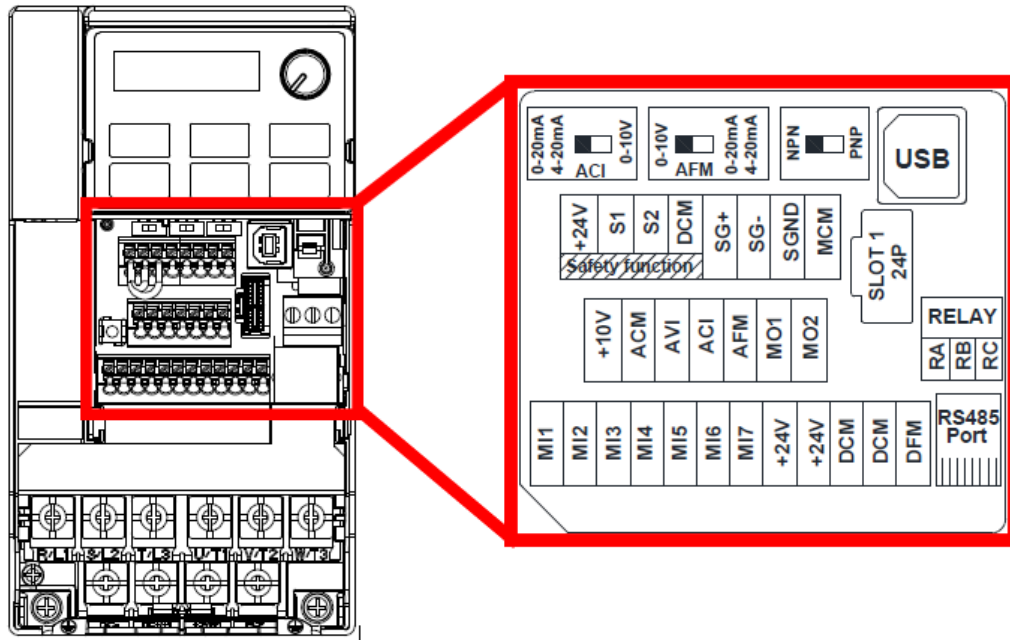

### Control Terminations on Variable Frequency Drive

V Series Washer Model	Input Voltage	Max Spin Speed	Jumper Terminal Locations on Variable Frequency Drive (VFD)												
			MI1	MI2	MI3	MI4	MI5	MI6	DCM (Left)	DCM (Right)	24V	ACM	AVI	ACI	10V
T-950	240V	140 G	REMOVE Brown Jumper Between MI5/M01												
		200G											X		X
	208V	140 G	REMOVE Brown Jumper Between MI5/M01												
		200G	No Jumper required												

### T-950 Spin Speed Adjustment Jumper Locations

The washer control may be programmed to send six 120V (60 Hz models) or six 24V (50 Hz models) output signals for a chemical injection system of up to four chemical sources. The signals are not intended as a power source and must be limited to less than 100 milliamps of current. There is a separate terminal block for connection of the external injection signals. For the injection sources, program codes 0 through 6 and their respective terminal block connections are as shown below:

Dexter Recommended Connections	Controller Programmed Signals	Injection Terminal Block Circuits
Detergent	1	A
Bleach	2	B
Starch	3	C
Sour/Softener	4	D
	5	A and B
	6	C and D
	0	None

#### **Injection Signal and Circuit Identification**

If required, chemical injection hoses are to be inserted into the injection inlet at the upper right rear of the washer. These hoses should be inserted into the round PVC pipe a distance of:

For T-400 and T-450 minimum of 8" (20 cm) and a maximum of 12" (30 cm)

For T-600, 650, 750, 900, 950, 1200, 1450, and 1800 a minimum of 14" (36 cm) and a maximum of 18" (46 cm)

(For T-300 and T-350 insert hoses into the top soap dish)

This will eliminate chemical buildup in the pipe and/or restrict water flow to the tub. Secure the hoses as required.

## 2.12 OPERATION CHECK

After all mounting, plumbing and electrical work is completed, run the machine through a complete wash cycle. Check for water leaks and verify proper operation.

During intermediate spin and final spin, the cylinder should turn in a **counterclockwise** direction when viewed from the front of the machine. If spin is clockwise, the T1 and T2 motor wires connecting to terminal T1 and T2 on the variable frequency drive should be swapped. Remove power to the machine before opening service panels and swapping wires.

### 3 OPERATING INSTRUCTIONS

#### 3.1 STARTING THE WASHER

*3.1.1 Turn on power to the washer.*

*3.1.2 Ensure washer is in "RUN" mode.*

Locate the "RUN/PROGRAM" key switch and key. The current mode is indicated by the alignment of the key slot. If washer is not in "RUN" mode, insert and turn the key to the "RUN" position.

*3.1.3 Load the laundry.*

Place laundry loosely into the cylinder and latch the door securely. Be sure laundry does not get caught between the door gasket and tub front when closing the door. Maximum load is the dry weight capacity listed in the specification sheet. Do not exceed the listed capacity weight.

**NOTE:** To begin closing the door, the handle must be in the horizontal position. After moving the door to the closed position, the handle must be turned down to the vertical position in order to latch the door for machine operation.

*3.1.4 Select wash cycle.*

Select the appropriate cycle number (1 through 6) for the type of load being washed. See the default cycle descriptions in section 3.2. Use the "UP" and "DOWN" keys to change the two digit cycle number on the display to the desired cycle.

*3.1.5 Add washing chemicals.*

If not using a chemical injection system, add low sudsing powdered detergent into the "DETERGENT" compartment of the automatic dispenser on the top of the washer.

If liquid wash products are used in the "DETERGENT" compartment, they must be added at the beginning of the wash cycle.

If desired, add fabric softener to the "FABRIC SOFTENER" compartment. Use the amount of fabric softener as recommended by the manufacturer.

If the machine is set for pre-wash, washing products can be added to the round opening of the dispenser or put in with the clothes when loading the washing machine.

If bleach is desired, DO NOT place into dispenser until bleach light blinks during the wash cycle.

*3.1.6 Press "START".*

The display will go blank for a moment and then display the cycle time in minutes. The door will lock and remain locked until the end of the cycle.

### 3.2 END OF CYCLE

When the cycle is complete, the time will display "0" and a 5-second tone will sound. The door can now be opened. Immediately remove contents of washer. Leave the door open when the machine is not in use.

### 3.3 SAFETY DOOR LOCK

This machine is equipped with a safety door lock that locks the door when the cycle is started until the cycle is complete. The door lock prevents opening the door for up to 3 minutes if the power is interrupted during the cycle.

### 3.4 VARIABLE FREQUENCY DRIVE INDICATORS

There are three small colored LEDs located on the upper region of the Variable Frequency Drive (VFD). They are labeled as "READY", "RUN", and "FAULT" and can be used for troubleshooting. The definitions of the LEDs are listed in the table below.



LED Status	Washer Condition
Steady Yellow	Tumbling
Blinking Yellow	Stop from Tumble
Steady Yellow	Ramp to Intermediate or Final Extract Spin
Steady Yellow	Spinning (Intermediate or Final)
Blinking Yellow	Stop from Spin (Intermediate or Final)
Steady Green	Idle Mode (No Cylinder Movement)
Steady Red	VFD fault
Blinking Red	VFD warning

**Variable Frequency Drive Indicators**

## 4 MACHINE PROGRAMMING INSTRUCTIONS

This Dexter washer is programmed with 6 factory default programs available for use immediately after installation. Any of these cycles, listed and detailed in section 3.2, can be customized to include up to 8 baths with various defined settings including Cycle Time, Water Temperature, Water Level, Type of Fill, Spin Time, and Injection Source. Programming can be accomplished manually using the machine controls or by connecting to the machine control using a PDA (**P**ersonal **D**igital **A**ssistant). For instructions on using a PDA with this washer control, please contact your local Dexter laundry equipment distributor. Please read below for manual programming instructions.

### 4.1 EDITING AN EXISTING CYCLE

#### 4.1.1 *Turn on the power to the washer.*

Washer must be in idle mode to program.

#### 4.1.2 *Ensure washer is in "PROGRAM" mode.*

Locate the "RUN/PROGRAM" key switch and key. The current mode is indicated by the alignment of the key slot. If washer is not in "PROGRAM" mode, insert and turn the key to the "PROGRAM" position.

The display will show "C\_\_0". The "ADD BLEACH" light will blink and will continue to blink during the programming mode.

#### 4.1.3 *Select cycle to alter.*

Press the "DOWN" or "UP" buttons on the keypad, as shown below, until the desired cycle number, 01 through 06, is displayed.

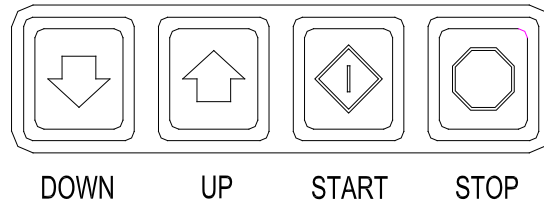

**Washer Control Keypad Layout**

#### 4.1.4 *Press "START" to enter the cycle.*

The display should now show a "b".

#### 4.1.5 *Select a bath to alter.*

Press the "UP" and "DOWN" buttons to select a bath. The mode indicator lights, as shown below, illuminate to indicate which bath is being selected.

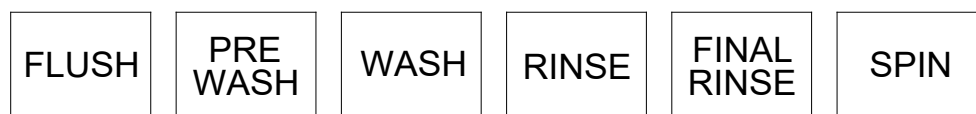

**Washer Mode Lights**

There are 8 available baths to program: FLUSH, PREWASH, WASH, RINSE1, RINSE 2, RINSE 3, RINSE 4, and FINAL RINSE.

When "RINSE" is illuminated, up to 4 rinses may be programmed. Each rinse is shown on the display as "b r1" through "b r4".

*4.1.6 Press "START" to display the settings.*

Available settings to alter in each bath are Cycle Time, Water Temp, Water Level, Type of Fill, Spin Time, and Injection Source.

*4.1.7 Input settings.*

The first setting to alter is the Cycle Time, shown on the display as "Ct\*\*" where \*\* is a placeholder for the options digits. Use the "DOWN" and "UP" keys to set the desired time in minutes and press "START" to advance to the next setting. If no change is desired, press "START" to advance to the next setting. Repeat process for each setting. Each bath setting can be programmed with the options shown below.

<i>SETTING</i>	<i>DISPLAY</i>	<i>OPTIONS</i>
Cycle Time	Ct**	Two-digit amount of time for bath in minutes. - 00 to 15 minutes for Flush, Prewash, Wash, Rinse 1, 2, 3 and 4. If the time is set to 00, then the bath will be eliminated from the cycle. - 01 to 15 minutes for Final Rinse.
Water Temperature	t_**	HH for hot water CH for warm water CC for cold water EE for no water <sup>2</sup>
Water Level	L_**	Lo for low level HI for high level
Type of Fill <sup>1</sup>	dF_*	d for delayed fill (default) t for timed fill
Spin Time	S_**	Two-digit amount of time for spin in minutes. - 00 to 10 minutes for Flush, Prewash, Wash, Rinse 1, 2, 3 and 4 - 01 to 10 minutes for Final Rinse
Injection Source <sup>2</sup>	IS_*	Single-digit code indicating injector signal(s), 0 to 6.

**Bath Program Settings**

<sup>1</sup> A delayed fill will pause the cycle time countdown until the selected low level is reached. A timed fill will allow the cycle time countdown to continue regardless of water level reached.

<sup>2</sup> Codes for injections sources are defined in section 2.12. When "EE" is selected in the Water Temperature setting, the electronic controller prohibits injection signals. The programmed injection source value is ignored.

*4.1.8 To exit the programming of a bath, press the "STOP" button.*

If desired, repeat steps 3.1.5 through 3.1.7 to program another

bath.

4.1.9 *To select a different cycle to program, press the "STOP" button again.*

If desired, repeat steps 3.1.3 through 3.1.8 to program another cycle.

4.1.10 *To end programming, turn the key to "RUN" position.*

It is recommended when changes are made to one or more of the preset programs that the cycle number and the changes be documented for later reference. Blank cycle tables have been provided at the end of section 4.2.

**NOTE:** The Wash Cycle programming mode will automatically exit and return to the Idle mode if no buttons are pressed for one minute.

## 4.2 DEFAULT WASHER CYCLE PROGRAMS

The factory default cycles pre-programmed into the washer are listed with each bath and setting option in this section.

<b>Cycle #</b>	<b>Recommended Use</b>
1	Sheets & Pillowcases (Health Care)
2	Towels / Pads / Diapers (Health Care)
3	White Towels (Hotel / Motel)
4	Guest Laundry (Hotel / Motel or Health Care)
5	Rags & Mops (Hotel / Motel)
6	Colored Cotton Linen (Food & Beverage)

**Cycle 1** Sheets & Pillowcases (Health Care)

Bath	Bath Cycle Time (min.)	Water Temp.	Water Level	Delay Fill	Spin Time (min.)	Injection Source
Flush	3	CH	HI	d		
Prewash	2	CH	HI	d		
Wash	7	HH	LO	d		1 (Detergent)
Rinse 1	7	HH	LO	d		2 (Bleach)
Rinse 2	2	CH	HI	d	1	
Rinse 3	2	CH	HI	d		
Rinse 4						
Final Rinse	4	CH	LO	d	6	4 (Sour/Soft)

**Cycle 2** Towels / Pads / Diapers (Health Care)

Bath	Bath Cycle Time (min.)	Water Temp.	Water Level	Delay Fill	Spin Time (min.)	Injection Source
Flush	3	CH	HI	d		
Prewash	2	CH	HI	d		
Wash	7	HH	LO	d		1 (Detergent)
Rinse 1	1	HH	HI	d		
Rinse 2	7	HH	LO	d		2 (Bleach)
Rinse 3	2	CH	HI	d	1	
Rinse 4	2	CH	HI	d		
Final Rinse	4	CH	LO	d	7	4 (Sour/Soft)

**Cycle 3** White Towels (Hotel / Motel)

Bath	Bath Cycle Time (min.)	Water Temp.	Water Level	Delay Fill	Spin Time (min.)	Injection Source
Flush						
Prewash						
Wash	7	HH	LO	d		1 (Detergent)
Rinse 1	1	HH	HI	d		
Rinse 2	7	HH	LO	d		2 (Bleach)
Rinse 3	2	CH	HI	d	1	
Rinse 4	2	CH	HI	d		
Final Rinse	4	CH	LO	d	7	4 (Sour/Soft)

**Cycle 4** Guest Laundry (Hotel / Motel or Health Care)

Bath	Bath Cycle Time (min.)	Water Temp.	Water Level	Delay Fill	Spin Time (min.)	Injection Source
Flush	3	CH	HI	d		
Prewash						
Wash	7	HH	LO	d		5 (Detergent/Bleach)
Rinse 1	2	HH	HI	d		
Rinse 2	2	CH	HI	d		
Rinse 3	2	CH	HI	d		
Rinse 4						
Final Rinse	4	CH	LO	d	6	4 (Sour/Soft)

**Cycle 5** Rags & Mops (Hotel / Motel)

Bath	Bath Cycle Time (min.)	Water Temp.	Water Level	Delay Fill	Spin Time (min.)	Injection Source
Flush	3	CH	HI	d		
Prewash	2	CH	HI	d		
Wash	2	CH	HI	d		
Rinse 1	7	HH	LO	d		1 (Detergent)
Rinse 2	2	HH	HI	d		
Rinse 3	7	HH	LO	d		2 (Bleach)
Rinse 4	2	CH	HI	d	1	
Final Rinse	2	CH	LO	d	7	

**Cycle 6** Colored Cotton Linen (Food & Beverage)

Bath	Bath Cycle Time (min.)	Water Temp.	Water Level	Delay Fill	Spin Time (min.)	Injection Source
Flush	2	CH	HI	d		
Prewash						
Wash	10	HH	LO	d		1 (Detergent)
Rinse 1	7	HH	LO	d		2 (Bleach)
Rinse 2	2	CH	HI	d	1	
Rinse 3	2	CH	HI	d		
Rinse 4						
Final Rinse	4	CH	LO	d	6	6 (Sour/Starch)

**Cycle \_\_\_\_\_ Description \_\_\_\_\_**

Bath	Bath Cycle Time (min.)	Water Temp.	Water Level	Delay Fill	Spin Time (min.)	Injection Source
Flush						
Prewash						
Wash						
Rinse 1						
Rinse 2						
Rinse 3						
Rinse 4						
Final Rinse						

**Cycle \_\_\_\_\_ Description \_\_\_\_\_**

Bath	Bath Cycle Time (min.)	Water Temp.	Water Level	Delay Fill	Spin Time (min.)	Injection Source
Flush						
Prewash						
Wash						
Rinse 1						
Rinse 2						
Rinse 3						
Rinse 4						
Final Rinse						

**Cycle \_\_\_\_\_ Description \_\_\_\_\_**

Bath	Bath Cycle Time (min.)	Water Temp.	Water Level	Delay Fill	Spin Time (min.)	Injection Source
Flush						
Prewash						
Wash						
Rinse 1						
Rinse 2						
Rinse 3						
Rinse 4						
Final Rinse						

### 4.3 RAPID ADVANCE MODE

Rapid Advance mode is a key-controlled override to interrupt the current cycle, drain the water, and advance to the next mode of the wash cycle, including Pre Wash, Wash, Rinse, Final Rinse, Spin. The indicator lights will show to which segment the cycle has been advanced.

To enter the Rapid Advance mode, turn the key counter-clockwise (CCW). The Rapid Advance setting is not marked next to the key, but turning the key CCW until it stops selects this mode. The Rapid Advance mode can be entered from either the Idle mode or during the cycle. If the cycle has not yet started, press the "START" button. To rapid advance to the next step in the wash cycle, push both the "UP" and "START" buttons at the same time. The display will show "Ad" (advance) in the display. The washer will advance to the next bath segment only after the water is drained from the washer.

**Note:**

- The time displayed may not be accurate.
- The cycle will continue in rapid advance mode even if the key is turned to "RUN" and/or removed.
- Rapid advance cannot skip the final 1-minute tumble of the cycle, and the door lock may remain activated for a couple minutes after the cycle has been completed.
- The chemical injection signals will NOT operate in Rapid Advance mode.

**To end the cycle without waiting for the time to count down, press and hold the "STOP" button for 5 seconds or more.**

#### 4.4 WATER LEVEL ADJUSTMENT

The water level of all baths can be adjusted by changing the switch settings on the electronic pressure sensor. On-premise washers are shipped with the pressure sensor harness connected to Switch #1 for "LO" level and Switch #2 for "HI" level.

Water level adjustments can also be made in 1/4" (6 mm) increments by adjusting the switch positions for the desired level. It is not recommended for the water level to be set above the factory Switch #2 settings. Refer to the following chart for the switch settings and the factory default settings:



## Water Level Chart

Switch Positions:							Factory Settings:				
Depth inches (mm):	Pos 1	Pos 2	Pos 3	Pos 4	Pos 5	Pos 6	Model	OPL			
								Switch #1 Low Level		Switch #2 High Level	
								Inches (mm)		Inches (mm)	
5.00 (127)	off	off	off	off	off	off	T-300	6.00	(152)	6.75	(171)
5.25 (133)	on	off	off	off	off	off	T-350	6.00	(152)	6.75	(171)
5.50 (140)	off	on	off	off	off	off	T-350 SWD	6.00	(152)	6.75	(171)
5.75 (146)	on	on	off	off	off	off	T-400	8.00	(203)	11.00	(279)
6.00 (152)	off	off	on	off	off	off	T-450	6.00	(152)	8.50	(216)
6.25 (159)	on	off	on	off	off	off	T-450 SWD	6.00	(152)	8.50	(216)
6.50 (165)	off	on	on	off	off	off	T-600	8.00	(203)	11.00	(279)
6.75 (171)	on	on	on	off	off	off	T-650	8.00	(203)	11.00	(279)
7.00 (178)	off	off	off	on	off	off	T-750	6.00	(152)	8.75	(222)
7.25 (184)	on	off	off	on	off	off	T-750 SWD	9.25	(235)	11.75	(298)
7.50 (191)	off	on	off	on	off	off	T-900	6.00	(152)	8.75	(222)
7.75 (197)	on	on	off	on	off	off	T-950	6.00	(152)	8.75	(222)
8.00 (203)	off	off	on	on	off	off	T-1200	6.00	(152)	8.75	(222)
8.25 (210)	on	off	on	on	off	off	T-1450	6.75	(171)	9.50	(241)
8.50 (216)	off	on	on	on	off	off	T-1800	6.75	(171)	9.50	(241)
8.75 (222)	on	on	on	on	off	off					
9.00 (229)	off	off	off	off	on	off					
9.25 (235)	on	off	off	off	on	off					
9.50 (241)	off	on	off	off	on	off					
9.75 (248)	on	on	off	off	on	off					
10.00 (254)	off	off	on	off	on	off					
10.25 (260)	on	off	on	off	on	off					
10.50 (267)	off	on	on	off	on	off					
10.75 (273)	on	on	on	off	on	off					
11.00 (279)	off	off	off	on	on	off					
11.25 (286)	on	off	off	on	on	off					
11.50 (292)	off	on	off	on	on	off					
11.75 (298)	on	on	off	on	on	off					
12.00 (305)	off	off	on	on	on	off					
12.25 (311)	on	off	on	on	on	off					
12.50 (318)	off	on	on	on	on	off					
12.75 (324)	on	on	on	on	on	off					
13.00 (330)	off	off	off	off	off	on					
13.25 (337)	on	off	off	off	off	on					
13.50 (343)	off	on	off	off	off	on					
13.75 (349)	on	on	off	off	off	on					
14.00 (356)	off	off	on	off	off	on					
14.25 (362)	on	off	on	off	off	on					
14.50 (368)	off	on	on	off	off	on					
14.75 (375)	on	on	on	off	off	on					
15.00 (381)	off	off	off	on	off	on					

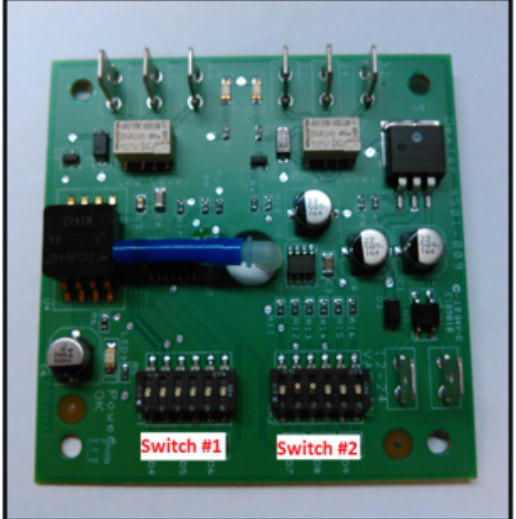

## 5 DISPLAYED WASHER MESSAGES

Fault # (F #)	Description	Customer Action
1	The door failed to close and lock or the door failed to remain locked after three tries of latching the door and starting during the cycle.	Turn off the power to the washer. Check wire connections to door /lock switches. Check wire connections from switches to controller. If necessary door lock mechanism should be adjusted by a qualified person. Turn on the power to the washer. (See Note)
2	The washer tub does not fill with water within 7 minutes. The wash cycle will continue. The F 2 will flash three times, then wait for 30 seconds. The error will clear at the end of the cycle.	Turn of the power to the washer. Check the operation of the water valves. Check the incoming water pressure. Check for blocked or restricted water flow. Check to ensure the drain valve is functioning properly. Turn on the power to the washer. (See Note)
3	Memory error in controller.	Turn off the power to the washer. Wait one minute. Turn power back on to the washer. If the problem returns, clear the fault with the Palm. If the problem returns again, replace the washer controller.
4	Washer controller communication error	Turn off the power to the washer. Wait one minute. Turn power back on to the washer. If the problem returns, replace the washer controller.
5	Pressure Switch error ( only OPL )- when the high level sensor indicates full but the lower one indicates empty. The wash cycle will continue. The F 5 will flash three times, then wait for 30 seconds. The error will clear at the end of the cycle.	Turn off the power to the washer. Replace the pressure switch. Turn on power to the washer. (See Note)
6	Wrong washer size for drive type.	Turn off the power to the washer. Check to ensure all the harnesses are properly connected to the controller. Check to ensure the drive horsepower is proper for this size of washer. Turn on power to the washer. (See Note) If problem reappears, contact your Dexter representative.
7	Wrong size drive installed	Turn off the power to the washer. Check to ensure all the harnesses are properly connected to the controller. Check to ensure the drive horsepower is proper for this size of washer. Contact your Dexter representative.
8	The washer tub does not empty within 7 minutes. The wash cycle will continue. The F 8 will flash three times, then wait for 30 seconds. The error will clear at the end of the cycle.	Turn off the power to the washer. Check to ensure the drain valve is operating properly. Check to ensure the pressure switch tube is clear of blockage. Check to ensure the pressure switch is operating proper. Correct any located problems. Turn on power to the washer. (See Note)
9	The washer tub does not reach the spin target frequency within 200 seconds. The wash cycle will continue. The F 9 will flash three times, then wait for 30 seconds. The error will clear at the end of the cycle.	Turn off the power to the washer. Inspect the washer to ensure the tub spins freely. If restricted, then clear the blockage. Test washer. If tub spins freely, the drive needs to be replaced.
10	After a spin the washer tub does not stop within 150 seconds.	Turn off the power to the washer. Inspect the braking resistors and the connecting wiring to the drive braking resistors mounted in the top of the washer. If the resistors and wiring is correct, then replace the drive.

11	The drive size setting has changed.	Turn off the power to the washer. Check to ensure all the harnesses are properly connected to the controller. Check to ensure the drive horsepower is proper for this size of washer. Turn on power to the washer. (See Note) If problem reappears, contact your Dexter representative.
12	Washer controller internal error	Turn off the power to the washer. Wait one minute. Turn on the power to the washer. (See Note) If problem reappears, contact your Dexter representative.
13	The control cannot communicate with the drive	Turn the power off to the washer. Check the data cable between the controller and the drive. If no problem is observed, turn on power to the washer and test. (See Note) If problem reappears, contact your Dexter representative.
14	Over-current on the drive or motor.	Turn the power off to the washer. Check the washer motor to ensure it turns freely. Check the wiring connections to the drive and motor. If no problem is observed, turn on power to the washer and test. (See Note) If problem reappears, contact your Dexter representative.
15	Over-voltage on the drive or motor.	Turn the power off to the washer. Check the washer motor to ensure it turns freely. Check the wiring connections to the drive, braking resistors and motor. Measure incoming line voltage. If no problem is observed, turn on power to the washer and test. (See Note) If problem reappears, contact your Dexter representative.
16	Overheating of the drive	Turn the power off to the washer. Allow the drive to cool. Check the cooling fins of the drive to ensure proper airflow. Check the wiring to the drive including the fan wiring. If no problem is observed, turn on power to the washer and test. (See Note) If problem reappears, contact your Dexter representative.
17	Overload of the drive or motor	Turn the power off to the washer. Check the washer motor to ensure it turns freely. Check the wiring connections to the drive and motor. If no problem is observed, turn on power to the washer and test. (See Note) If problem reappears, contact your Dexter representative.
18	Ground Fault to the drive	Turn the power off to the washer. Check the wiring connections to the drive and motor. Check the ground wiring of the drive, motor and incoming connection to ensure a proper ground is present. If no problem is found, contact your Dexter representative.
19	Low Voltage to the drive	Turn the power off to the washer. Check the wiring connections to the drive and motor. If no problem is observed, turn on power to the washer and test. (See Note) Measure the incoming line voltage. If problem reappears, contact your Dexter representative.
20	Internal drive error	Turn the power off to the washer. Wait one minute. Turn the power on to the washer. (See Note) If problem reappears, contact your Dexter representative.
21	Data error on communications between the controller and drive	Turn the power off to the washer. Check the data cable between the controller and the drive. If no problem is observed, turn on power to the washer and test. (See Note) If problem reappears, contact your Dexter representative.
29	Drive Phase Loss	Turn the power off to the washer. Check the wiring connections to the drive and motor. If no problem is observed, turn on power to the washer and test. (See Note) Measure the incoming line voltage. If problem reappears, contact your Dexter representative.
30	Internal Drive Error	Turn the power off to the washer. Wait one minute. Turn the power on to the washer. (See Note) If problem reappears, contact your Dexter representative.
31	Drive Certification Check Error	Turn the power off to the washer. Wait one minute. Turn the power on to the washer. (See Note) If problem reappears, contact your Dexter representative.

Note: Whenever power is turned off to the washer, it **must** remain off for one minute. The washer will not operate properly if this is not done.

## 6 TROUBLESHOOTING

**CAUTION:** Label all wires prior to disconnection when servicing controls. Wiring errors can cause improper and dangerous operation. Verify proper operation after servicing.

**ATTENTION:** Lors des opérations d'entretien des commandes, étiqueter tous les fils avant de les déconnecter. Toute erreur de câblage peut être une source de danger et de panne.

If any of the following symptoms occur on this washer, check the suggested remedies listed below. If all probable causes have been eliminated and the symptom still exists, contact your local Dexter agent for further troubleshooting assistance. See contact information at the end of this manual. Parts & Service Manuals from Dexter are also available for further troubleshooting assistance.

Symptom	Probable Cause	Suggested Remedy
<b>Machine does not start</b>	Power Supply	Check these areas: Circuit breakers, Voltage, Power leads, Power connections. Is front display LED lit?
	Door Switch	Check for continuity through door switch when door is closed. If no continuity, adjust or replace door switch.
	Control Breaker or Fuse	60 Hz: Check 1.5 amp (T-950, T-1200 and T-1450 use 2.5amp) breaker or fuse (50 Hz: 7 amp) for continuity. If no continuity, replace breaker or fuse.
	Control Transformer	Check voltage output from control transformer for 120VAC (60 Hz) or 24 VAC (50 Hz). If voltage is incorrect, replace transformer.
	Check PCB board	Check all wire connections for sure contacts.
	Check wiring between PCB	Check data cable phone type connectors unplug and VFD and replug with power removed.
	Check Relay PCB	Check all wire connections for sure contact.
	Check Door Lock Mechanism	Check that 120 VAC (60 Hz) or 24 VAC (50 Hz) power is at mechanism after start button is pressed.
<b>Door does not lock</b>	Check display for fault code	Does F1 show on the front of display? If yes, follow tests described in fault code section.
	Door locking mechanism	Check to ensure that mechanism is receiving 120VAC (60 Hz) or 24 VAC (50 Hz) from main relay PCB. If it is, replace.
	Door Switch	Check for continuity through door latch switch when door closed. If no continuity, adjust or replace door switch.
<b>Door will not open</b>	Thermoactuator	Check to see if thermoactuator(s) and/or its mechanism is stuck or binding and not allowing the door lock mechanism to open. Check to be sure that the locking thermoactuator is not receiving 120VAC (60 Hz) or 24 VAC (50 Hz) during the last 1 1/2 minutes of the cycle. Also check to see that the unlocking thermoactuator is receiving 120VAC (60 Hz) or 24 VAC (50 Hz) during the last minute of the cycle. If the timing and voltage are correct, replace the thermoactuator.
<b>Door will not open</b>	Door Rod	Check to see that door rod from mechanism to lock assembly is long enough to allow lock assembly to disengage. If not, adjust rod.
	Door locking mechanism	Check that door lock mechanism is not stuck closed. If stuck, replace.

<b>No hot water in detergent dispenser</b>	Water Valve Coil	Check coil continuity at terminals and replace if no continuity. 120 VAC (60 Hz) or 24 VAC (50 Hz) power only on for 20 second in wash bath.
	Water Inlet	Check water inlet screens for blockage and clean screens if necessary.
	Water	Check to ensure that water is turned on and operating.
	P-20 Wire Harness	Check black & white wire harness.
<b>Hot water does not enter tub in wash</b>	Water Valve Coil	Check coil continuity at terminals and replace if no continuity. Check for 120 VAC (60 Hz) or 24 VAC (50 Hz) power from main relay PCB.
	Water Inlet	Check water inlet screens for blockage and clean if necessary.
	Water	Check to ensure that water is turned on and operating.
	Blk or Wht wire at main controller	Check black or white wires at Molex plug on PCB at main controller and at relay PCB.
	Pressure Switch	Check pressure switch continuity between terminals. If no continuity, check pressure switch hose for obstruction. If hose okay, change pressure switch.
<b>No cold water to tub in wash</b>	Water Valve Coil	Check coil continuity at terminals and replace if no continuity.
	Water Inlet Screens	Check water inlet screens for blockage and clean if necessary.
	Water	Check to ensure that water is turned on and operating.
	Blk or whit wire at controller and main relay PCB	Check black or white wires at Molex plug on PCB at main controller and at relay PCB.
	Pressure Switch	Check pressure switch continuity between terminal contacts. If no continuity, check pressure switch hose for obstruction. If hose okay, change pressure switch.
<b>Water comes in but level does not rise</b>	Drain Valve (open)	Check these areas: <ul style="list-style-type: none"> <li>• Drain valve blockage</li> <li>• Drain valve motor and gear train. If power but drain valve does not close, replace valve.</li> <li>• Power to the drain valve. If no power to drain valve, check (brn/yel) circuit for power.</li> </ul>
	Blk or whit wire at controller	Check black and white wires at molex plug on main PCB controller and at main relay PCB
<b>Water does not flush softener compartment</b>	Water Valve Coil	Check coil continuity at terminals and replace if no continuity.
	Water Inlet Screens	Check water inlet screens for blockage and clean if necessary.
	Water	Check to ensure that water is turned on and operating.
<b>Water does not flush softener compartment</b>	Pressure Switch	Check pressure switch continuity between terminals. If no continuity, check pressure switch hose for obstruction. If hose okay, change pressure switch.
<b>Water level too high</b>	Pressure Switch	Check for blockage in pressure switch hose. Check for pressure switch opening circuit across terminals. Replace switch if contacts do not open.
<b>Water drains slowly</b>	Drain System	Check hoses and drain valve for blockage. Check if inadequate size. If necessary check building drains for blockage.

<b>Machine does not turn</b>	VFD	Check VFD by removing inspection panel and record any numbers or letters displayed. If no display turn power off to machine at breaker for 2 minutes and turn power back on to reset. If still no display, replace VFD.
<b>Machine tumbles in one direction</b>	VFD	Remove inspection cover at rear and record in only numbers or letters displayed. See fault code section for more info.
		Inspect yellow enable wires from main relay PCB and at VFD.
<b>Excessive vibration</b>	Mounting System	Check these areas: • Strength of mounting structure, concrete or base. • Mounting bolts may be loose and need tightening.
	Drive Belt	Worn drive belt can cause vibration and noise.
	Loading	Note: Small loads contribute to out of balance loading and increase vibration.
<b>Machine does not spin</b>	Pressure Switch	Check pressure switch for continuity across terminals #21 & #22 indicating pressure switch has reset to the empty position. If no continuity, change pressure switch.
<b>Machine starts and does not operate</b>	VFD	Check yellow enable wires from relay PCB P13 & motor P14to VFD advances through cycle are connected. Check fault code on VFD before removing power from the drive. Check orange P-15 wire for signal from door switches.
<b>Machine does not stop</b>	Main PCB	Main PCB controls time cycle at end of cycle
	Braking Resistors	Check braking resistors for continuity. Verify ohms resistance by Molex.
<b>Water leakage around loading door</b>	Door Adjustment	Door may need adjustment due to abuse or wear. Check tightness around perimeter using a dollar bill. Adjust left to right tightness by shims at door lock or hinge side. It is important to center gasket to tub opening before tightening door to hinge bolts. Chalk may be used on tub front to show point of contact with tub. If gasket is deformed, worn, or damaged, replace. Refer to parts section for door gasket expander kit.

## **7 TRANSIENT VOLTAGE SURGE SUPPRESSORS**

### **IMPORTANT**

Like most electrical equipment your new machine can be damaged or have its life shortened by voltage surges due to lightning strikes which are not covered by factory warranty. Local power distribution problems also can be detrimental to the life of electrical components. We recommend the installation of transient voltage surge suppressors for your new equipment. These devices may be placed at the power supply panel for the complete installation and don't require an individual device for each machine.

These surge protectors help to protect equipment from large spikes and also from small ongoing spikes in the power that occur on a day to day basis. These smaller surges can shorten overall life of electrical components of all types and cause their failure at a later date. Although they can't protect against all events, these protective devices have a good reputation for significantly lengthening the useful life of electronic components.

Electronic components are helped to have a longer useful life when they are supplied with the clean stable electrical power they like.

We are including the following names and links to a few suppliers of these devices for those who don't currently have a source.

#### **MANUFACTURER**

MCG Surge Protection

Eaton Corporation

Schneider Electric

Asco Power Technologies

Emerson Electric Co.

#### **LINK**

[mcgsurge.com](http://mcgsurge.com)

[eaton.com/us/en-us](http://eaton.com/us/en-us)

[se.com/us/en](http://se.com/us/en)

[ascopower.com/us/en](http://ascopower.com/us/en)

[emerson.com/en-us](http://emerson.com/en-us)

## 8 SERVICE AND PARTS

The following parts are provided with each machine for use in installation.

For T-300, 350, 400, 450, 600, 650, 750, 900

<u>Dexter Part Number</u>	<u>Description</u>	<u>Quantity</u>
9990-027-011 (60Hz)	Hose, Water Supply	2
9990-024-015 (50Hz)	Hose, Water Supply, Red end	1
9990-024-016 (50Hz)	Hose, Water Supply, Blue end	1
8641-242-000 (All)	Washer, Inlet Hose	2
9565-003-001 (All)	Strainer, Inlet Hose	2

For T-950, 1200, 1450, 1800

<u>Dexter Part Number</u>	<u>Description</u>	<u>Quantity</u>
9990-027-011 (60Hz)	Hose, Water Supply	2
9990-027-013 (60Hz)	Hose, Water Supply (Large)	2
9990-024-015 (50Hz)	Hose, Water Supply (Red end)	1
9990-024-016 (50Hz)	Hose, Water Supply (Blue end)	1
9990-024-017 (50Hz)	Hose, Water Supply (Red end-Large)	1
9990-024-018 (50Hz)	Hose, Water Supply (Blue end-Large)	1
8641-242-000 (All)	Washer, Inlet Hose	4
9565-003-001 (All)	Strainer, Inlet Hose	4

Contact distributor or Dexter Laundry, Inc. if a steel-mounting base is required.

For service and parts information, contact your local Dexter agent. To find your local Dexter agent, use the Distributor Locator at the website shown below. If a Dexter agent is not available, contact **Dexter Laundry, Inc.** directly as listed below:

Mailing Address: 2211 West Grimes Avenue Phone: 1-800-524-2954  
Fairfield, IA 52556  
USA

Website: [www.dexter.com](http://www.dexter.com)