

Kits, Assemblies, & Common Parts

Description	Model
Kit - 8650-012-003 Lock with spacer	9732-344-001
Kit - T450 SWD Dryer Mounting Kit	9732-339-001
Kit - A to C series Conversion, SWD Dryer, Black, 24v	9732-312-004
Kit - A to C series Conversion, SWD Dryer, Blue, 24v	9732-312-003
Lock with Spacer Replacement for 8650-012-003	9732-344-001
30lb SWD Makeup Air Kit	9732-333-001
Cleanout Duct Assembly 8"	9973-034-001
Temperature Probe	9501-004-003
Controls Blue	9857-148-001
Controls Black	9857-148-009
Coin Drop	9021-009-001
Coin Drop Switch/Optical Sensor	9539-466-005
Coin Drop Screws	9545-053-002 x4
Ignition Control (Before Serial #232998)	9857-116-003
Ignition Control (After Serial #232998)	9857-182-001
Electrode Assembly, Ignition	9875-002-003
Thermostat, Hi-Limit	9576-203-002
Thermostat, Overtemp	9576-207-008
Fuse	9200-001-002
Fuseholder	8636-018-001
Transformer, Ignition	8711-011-001
Lint Screen Assy w/o Front	9805-029-002
Air Flow Switch	9536-461-009
Door Switch	9539-487-001
Motor Belt	9040-073-009
Tumbler Belt	9040-077-001
Tension Arm Complete	9861-022-001
Spider/Trunnion	9568-011-001
Door Handle	9244-082-001

Section 5:

Dryer Parts Data

Dryer Cabinet Group Before Serial # 232998

Key	Description	Part Number	Qty
1	Loading Door Complete SS/Brushed SS/Gray	9960-256-030	1
1	Loading Door Complete SS/Chrome/Blk	9960-256-037	1
2	Door Assy, Loading (Ring only) Brushed SS	9960-255-008	1
2	Door Assy, Loading (Ring only) Chrome	9960-255-016	1
3	Plate Assy, Hinge (SS)	9982-280-011	1
4	Screw Hinge to Door	9545-012-015	4
*	Nut, Hinge to Door	8640-413-002	4
5	Glass, Door	9212-002-003	1
6	Gasket, Door Glass (Gray)	9206-164-009	1
6	Gasket, Door Glass (Black)	9206-413-001	1
*	Support Door Glass	9548-117-000	2
7	Gasket, Door Outer Rim (Gray)	9206-420-002	1
7	Gasket, Door Outer Rim (Black)	9206-420-003	1
8	Handle, Loading Door	9244-082-001	1
*	Screw, Handle	9545-018-017	2
*	Stud Door Catch	9531-033-001	1
*	Nut-Hex, #10-32	8640-413-001	1
*	Nut, Acorn	8640-413-003	1
*	Catch, Loading Door	9086-015-002	1
9	Strap, Hinge (Gray)	9544-047-007	1
9	Strap, Hinge (Black)	9544-047-011	1
10	Screw, Hinge to Door	9545-052-001	1
11	Washer-Fiber/Plastic	8641-436-003	1
12	Front Pannel Assy	9989-465-001	1
*	Insulation-Front Panel, Top Half	9277-053-001	1
*	Insulation-Front Panel, Bottom Half	9277-053-002	1
13	Name Plate-Dryer, SWD	9412-102-001	1
14	Escutcheon-Dryer Coin	9141-154-001	1
*	Screw-TRHD Torx, 6BSDx1/2,BLK	9545-031-009	10
15	Overlay-Escutcheon, Coin WSD w/ Holes	9435-009-001	1
15	Overlay-Escutcheon, Coin WSD w/o Holes	9435-009-003	1
16	Lock & Key Assy	8650-012-003	1
*	Key, Electronic Control (6324)	6292-006-007	1
*	Cam-Lock	9095-041-001	1
*	Washer-Flat Shim	8641-581-010	1
*	Washer-Flat	8641-581-041	1
*	Cabinet Touch Up Paint (White)	9472-001-013	1

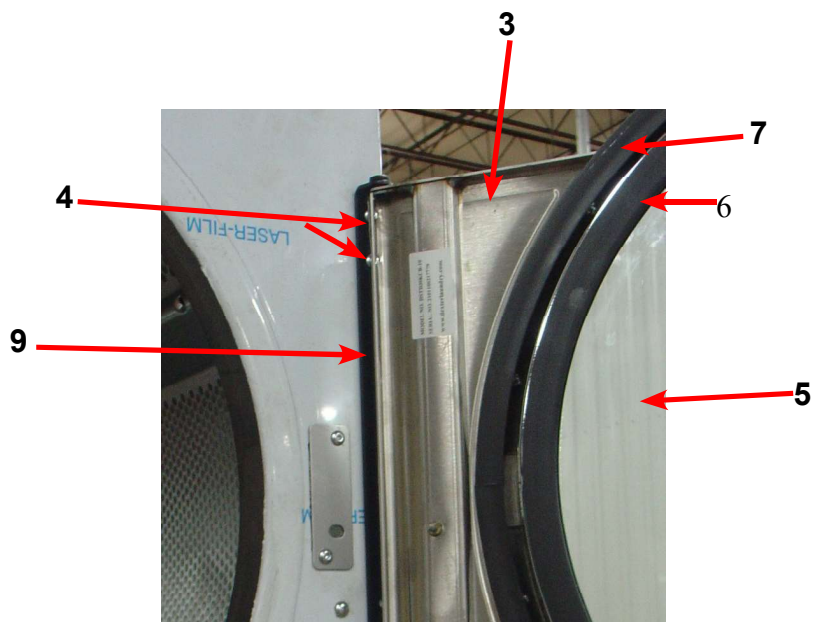

Dryer Cabinet Group After Serial #232998

Key	Description	Part Number	Qty
1	Loading Door Complete SS/Brushed SS/Gray	9960-256-030	1
1	Loading Door Complete SS/Chrome/Blk	9960-256-035	1
2	Door Assy, Loading (Ring only) Brushed SS	9960-255-008	1
2	Door Assy, Loading (Ring only) Chrome	9960-255-016	1
3	Plate Assy, Hinge (SS)	9982-280-012	1
4	Screw Hinge to Door	9545-012-028	4
*	Nut, Hinge to Door	8640-413-002	4
5	Glass, Door	9212-002-003	1
6	Gasket, Door Glass (Gray)	9206-164-009	1
6	Gasket, Door Glass (Black)	9206-413-001	1
*	Support Door Glass	9548-117-000	2
7	Gasket, Door Outer Rim (Gray)	9206-420-002	1
7	Gasket, Door Outer Rim (Black)	9206-420-003	1
8	Handle, Loading Door	9244-082-001	1
*	Screw, Handle	9545-018-017	2
*	Stud Door Catch	9531-033-001	1
*	Nut-Hex, #10-32	8640-413-001	1
*	Nut, Acorn	8640-413-003	1
*	Catch, Loading Door	9086-015-002	1
9	Strap, Hinge (Gray)	9544-047-007	1
9	Strap, Hinge (Black)	9544-047-011	1
10	Screw, Hinge to Door	9545-052-001	1
11	Washer-Fiber/Plastic	8641-436-003	1
12	Front Pannel Assy	9989-465-001	1
*	Insulation-Front Panel, Top Half	9277-053-001	1
*	Insulation-Front Panel, Bottom Half	9277-053-002	1
13	Name Plate-Dryer, SWD (Blue)	9412-102-001	1
13	Name Plate-Dryer, SWD (Black)	9412-202-001	1
14	Escutcheon-Dryer Coin	9141-154-001	1
*	Screw-TRHD Torx, 6BSDx1/2,BLK	9545-031-009	10
15	Overlay-Escutcheon, Coin SWD (Blue) W/Holes	9435-009-001	1
15	Overlay-Escutcheon, Coin SWD (Blue) W/o Holes	9435-009-003	1
13	Overlay-Escutcheon, Coin SWD (Black)	9435-035-001	1
16	Lock & Key Assy	8650-012-003	1
*	Key, Electronic Control (6324)	6292-006-007	1
*	Cam-Lock	9095-041-001	1
*	Washer-Flat Shim	8641-581-010	1
*	Washer-Flat	8641-581-041	1
17	Cover-Hinge, Black	9074-341-002	1
18	Screws-TRHDCR, 10B x 3/8, Black	8636-018-001	2
*	Cabinet Touch Up Paint (White)	9472-001-013	1

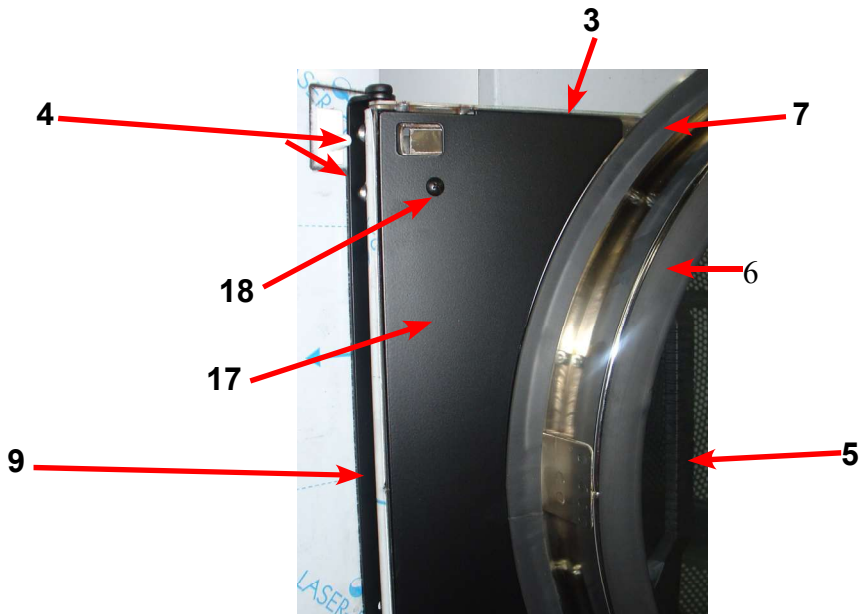
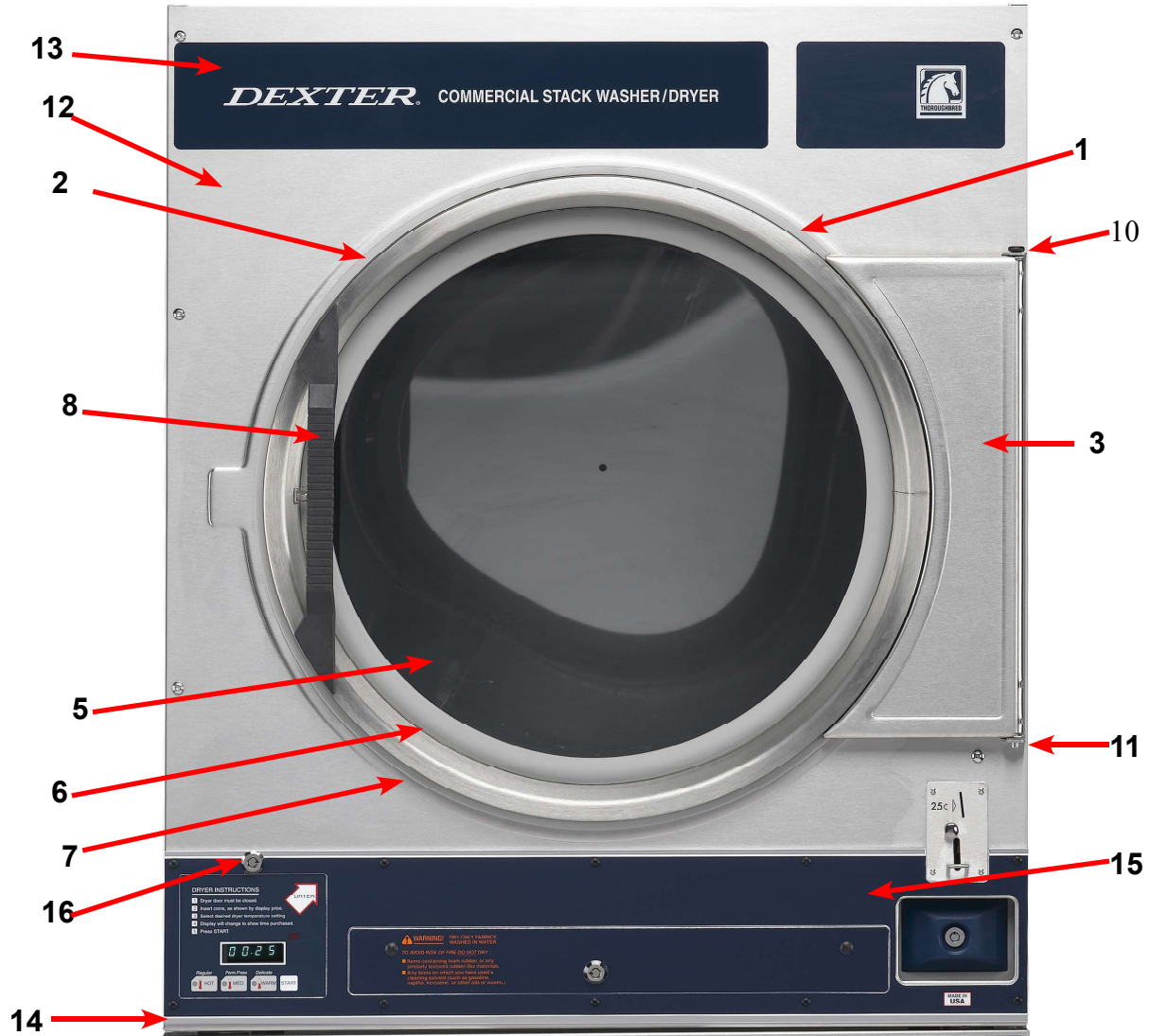

Dryer Cabinet Group Continued Before Serial #232998

Key	Description	Part Number	Qty
1	Control Assy-Stach Washer Dryer W/IR	9857-148-001	1
	Membrane Switch	9801-076-001	1
2	Lint Drawer Assy Complete W/Front	9866-004-001	1
*	Lint Screen Assy w/o Front	9805-029-002	1
*	Lint Drawer Front (Aluminum)	9974-010-001	1
3	Overlay, Lint Drawer	9435-003-009	1
*	Screen (Course)	9555-057-002	1
*	Screen (Fine Mesh)	9555-057-003	1
*	Felt-Seal (back of lint screen)	9532-074-003	1
*	Screw-Lint screen strap hold down	9545-008-001	14
4	Lock & Key Assy	8650-012-004	1
*	Key (6101)	6292-006-010	1
*	Cam, Lock	9095-043-001	1
*	Washer	8641-581-041	1
5	Door Switch	9539-461-001	1
5	Shield-Door Switch	9550-159-001	1
5	Box-Door Switch	9041-076-002	1
5	Screw- 4-40x5/8	9545-020-001	2
5	Twin Nut Special	8640-401-001	1
5	Acuator-Door Switch	9008-004-002	1
5	Cover-Switch Box	9074-255-001	1
6	Screw-TRHDTORX, 10ABx3/4	9545-008-020	2
*	Gromet, 1/4	9029-037-001	1
*	Conduit - Special	6068-043-001	1
*	Wire-BLK, 45"	8220-001-221	1
*	Wire-BLU, 45"	8220-001-222	1
*	Bracket Assy, Temp Sensor	9985-175-001	1
7	Temp Sensor	9501-004-003	1
*	Gromet	9209-037-002	1
*	Wire-Nut Gray	8640-276-002	2
*	Harness-Main Harness	9627-782-001	1
*	Harness-Door & Coin Switches	9627-783-001	1
*	Cabinet Cover	9074-261-001	1
*	Insulation, Cabinet Cover	9277-041-011	1
*	Coin Vault Assy (Black)	9942-027-015	1
*	Screw - #10Bx1/2	9545-008-026	4
8	Coin Box (Blue Front)	9807-099-001	1
9	Coin Acceptor	9021-009-001	1
*	Switch, Coin Mech	9539-466-005	1
*	Return, Coin Acceptor	9486-145-001	1
*	Screw, Retainer	9545-053-002	4

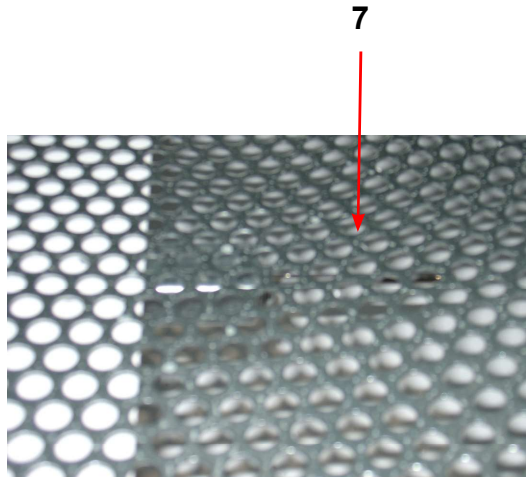
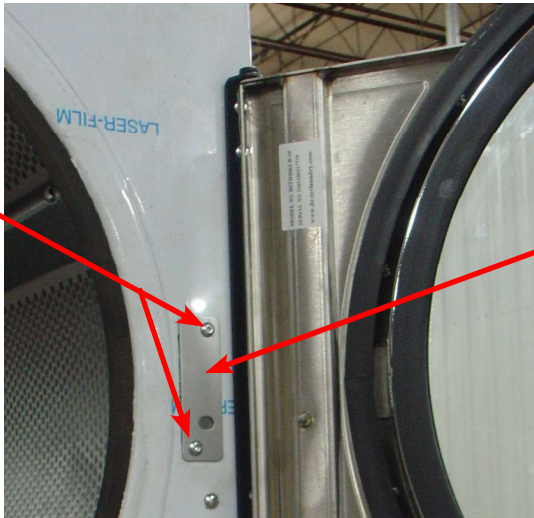

Dryer Cabinet Group Continued After Serial #232998

Key	Description	Part Number	Qty
1	Control Assy-Stach Washer Dryer W/IR (Blue)	9857-148-001	1
1	Control Assy-Stach Washer Dryer W/IR (Black)	9857-148-009	1
*	Membrane Switch (Blue)	9801-076-001	1
*	Membrane Switch (Black)	9801-109-001	
2	Lint Drawer Assy Complete W/Front (Blue)	9866-004-001	1
2	Lint Drawer Assy Complete W/Front (Black)	9866-004-011	
*	Lint Screen Assy w/o Front	9805-029-002	1
*	Lint Drawer Front (Aluminum)	9974-010-001	1
3	Overlay, Lint Drawer (Blue)	9435-003-009	1
3	Overlay, Lint Drawer (Black)	9435-029001	
*	Screen (Course)	9555-057-002	1
*	Screen (Fine Mesh)	9555-057-003	1
*	Felt-Seal (back of lint screen)	9532-074-003	1
*	Screw-Lint screen strap hold down	9545-008-001	14
4	Lock & Key Assy	8650-012-004	1
*	Key (6101)	6292-006-010	1
*	Cam, Lock	9095-043-001	1
*	Washer	8641-581-041	1
5	Door Switch	9539-487-001	1
*	Bracket Assy, Temp Sensor	9985-175-001	1
7	Temp Sensor	9501-004-003	1
*	Gromet	9209-037-002	1
*	Wire-Nut Gray	8640-276-002	2
*	Harness-Main Harness	9627-782-002	1
*	Harness-Door & Coin Switches	9627-783-003	1
*	Cabinet Cover	9074-261-001	1
*	Insulation, Cabinet Cover	9277-041-011	1
*	Coin Vault Assy (Black)	9942-027-015	1
*	Screw - #10Bx1/2	9545-008-026	4
8	Coin Box (Blue Front)	9807-099-001	1
8	Coin Box (Black Front)	9807-099-003	1
9	Coin Acceptor	9021-009-001	1
*	Switch, Coin Mech	9539-466-005	1
*	Return, Coin Acceptor	9486-145-001	1
*	Screw, Retainer	9545-053-002	4
*	Nut, Elastic Stop	8640-413-004	*

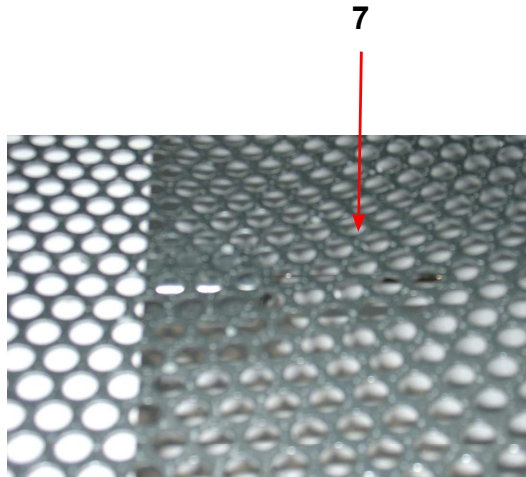

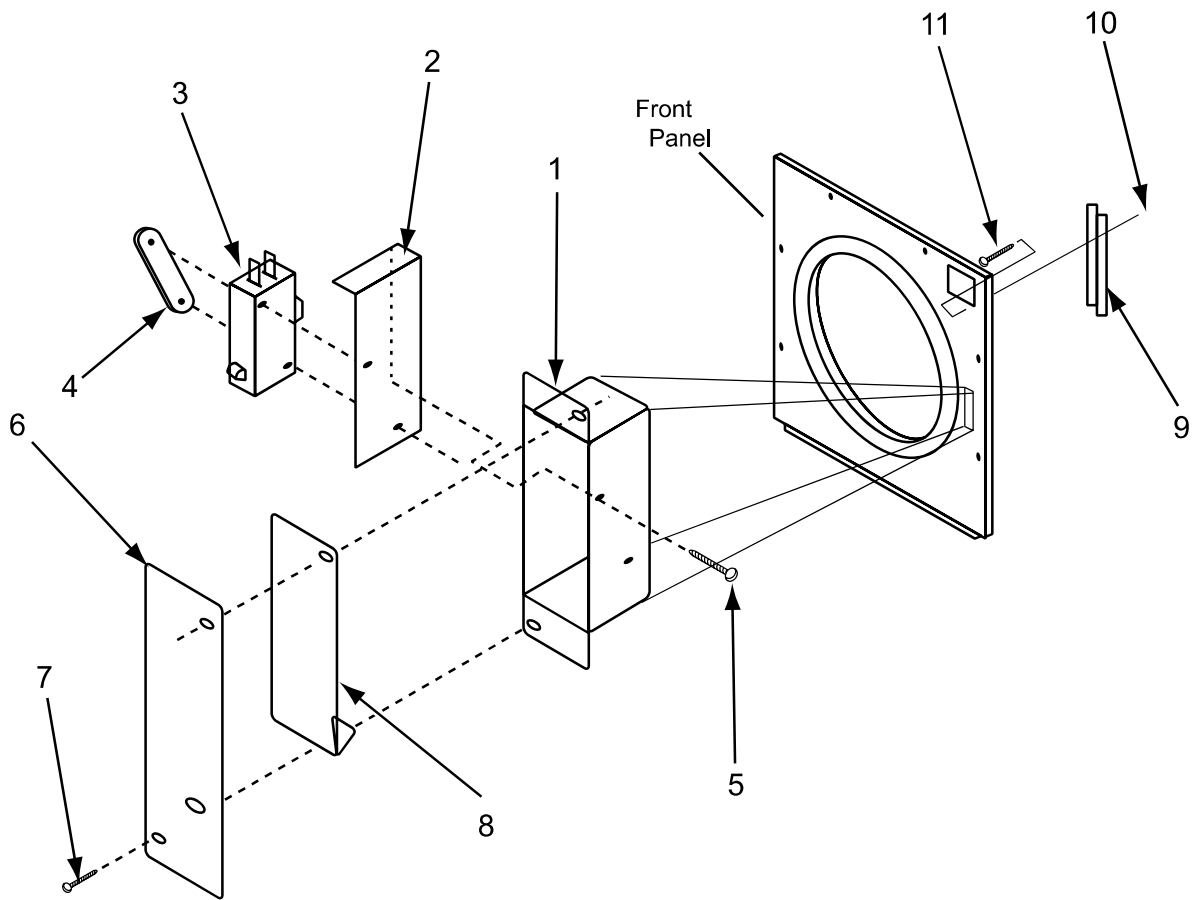

Key	Description	Part Number	Qty
1	Box-Door Switch	9041-076-002	1
2	Shield-Door Switch	9550-159-001	1
3	Door Switch	9539-461-001	1
4	Twin Nut Special	8640-401-001	1
5	Screw- 4-40x5/8	9545-020-001	2
6	Cover-Switch Box	9074-255-001	1
7	Screw-TRHDTORX, 10ABx3/4	9545-008-020	2
8	Acuator-Door Switch	9008-004-002	1
9	Conduit - Special	6068-043-001	1
10	Screw, 10-32x1/2	9545-012-003	1
11	Nut, Elastic Stop 10-32	8640-413-004	1
*	Gromet, 1/4	9029-037-001	1
*	Wire-BLK, 45"	8220-001-221	1
*	Wire-BLU, 45"	8220-001-222	1

Dryer Back Panels and Guards

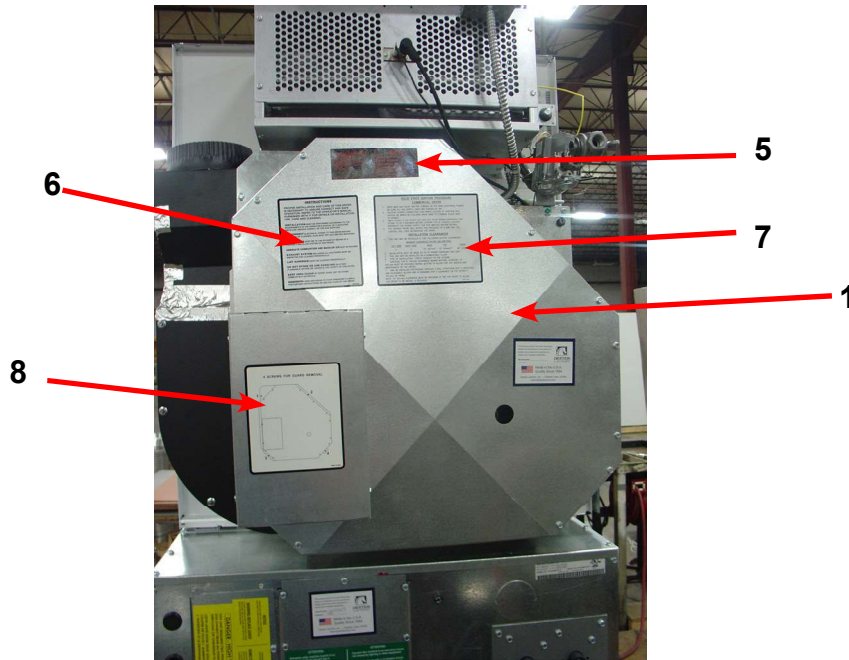
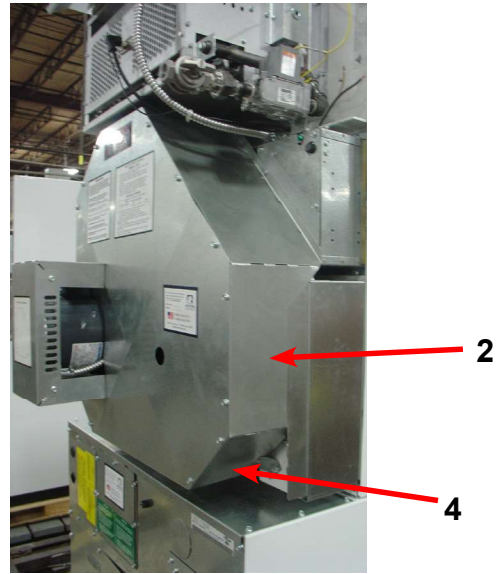

Key	Description	Part Number	Qty
1	Guard, Drive	9208-064-001	1
2	Panel, Drive Guard, LH Before Serial #232998	9454-740-001	1
	Panel, Drive Guard, LH After Serial#232998	9454-887-001	1
3	Panel, Drive Guard, RH	9989-481-001	1
4	Panel, Drive Guard Bottom	9454-739-001	1
*	Screw	9545-008-024	8
5	Warning, Lable	8502-600-001	1
6	Lable, Instructions	8502-645-001	1
7	Lighting and Clearence, Lable	8527-112-001	1
8	Lable, Guard Removal	8502-710-001	1

Dryer Burner Housing Group Before Serial #232998

Key	Description	Part Number	Qty
*	Housing Assembly, Burner	9803-199-001	1
1	Panel-Burner Housing Front & Back	9454-831-001	1
*	Panel-Burner Housing, Side Left	9454-789-001	1
2	Panel-Burner Housing, Side Right	9454-790-001	1
*	Baffle-Burner Housing	9049-080-001	1
*	Connector Assembly- Burner	9828-015-001	1
3	Panel-Burner Housing, Top	9454-791-001	1
4	Cover Burner Housing, Top	9074-307-001	1
*	Screw, 10Bx1/4	9545-008-001	4
*	Screw, 10ABx3/8	9545-008-006	23
*	Plate, Recirculation Cover	9452-729-001	1
*	Screw, 10Bx1/4	9545-008-001	6
*	Shield, Burner Inlet	9550-173-001	1
*	Screw, 10ABx3/8	9545-008-024	3
5	Burner, Main	9048-020-001	2
*	Panel- Burner Housing, Back	9454-816-001	1
*	Screw, 10Bx1/4	9545-008-001	4
6	Electrode-Ignition	9875-002-003	1
*	Screw, 8Bx1/4	9545-045-001	2
7	Thermostat-HI-Limit	9576-203-002	1
*	Bracket-Hi-Limit	9029-192-001	1
*	Spacer-Hi-Limit	9538-142-001	2
*	Screw, 8Bx3/4	9545-045-007	2
*	Wire Assy-BRN, 31"	8220-001-415	1
*	Wire Assy-ORG, 31"	8220-095-018	1
*	Thermostat-Over Temp, Manual Reset	9576-207-008	1
*	Screw, 10ABx3/8	9545-008-006	2
*	Bushing, Over Temp	2114-008-000	2
8	Cover Assembly, OverTemp Thermostat	9825-057-002	1
*	Screw, 10ABx3/8	9545-008-006	2
9	Control Assy,Gas Valve	9857-134-001	1
10	Manifold Assy	9381-009-001	1
*	Orfice-Natural, #32	9425-069-009	2
*	Orfice-LP, #50	9425-069-008	2
11	Bracket-Manifold, Gas	9029-047-001	1
12	Bracket-Control	9039-915-001	1
12	Bracket-Support, Gas Valve	9029-116-001	1
*	Elbow- 1/2x90, Black Iron	8615-104-037	2
*	Nipple- 1/2x2, Black Iron	8655-073-040	3
*	Nipple- 15xClose, Back Iron	8655-073-041	1
*	Union- 1/2, Black Iron	8615-104-035	1
*	Valve-Gas Shutoff, (Optional)	9379-196-001	1
13	Duct Assy, Recirculation	9973-033-001	1

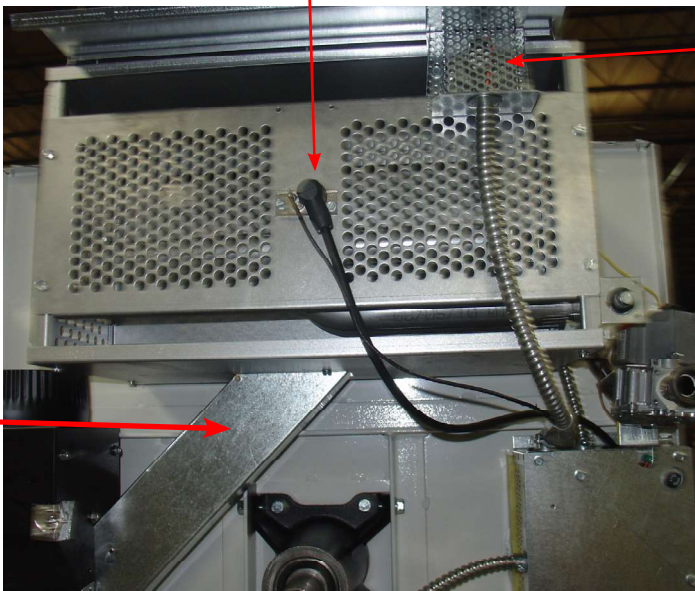
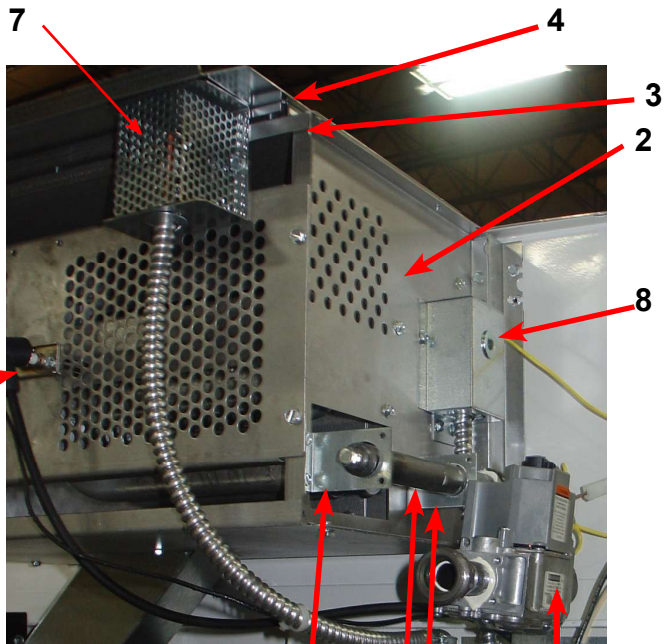
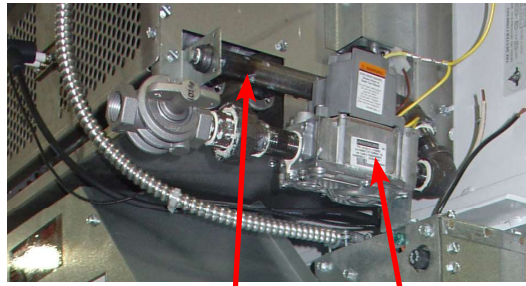

Dryer Burner Housing Group After Serial #232998

Key	Description	Part Number	Qty
*	Housing Assembly, Burner	9803-199-001	1
1	Panel-Burner Housing Front & Back	9454-831-001	1
*	Panel-Burner Housing, Side Left	9454-789-001	1
2	Panel-Burner Housing, Side Right	9454-790-001	1
*	Baffle-Burner Housing	9049-080-001	1
*	Connector Assembly- Burner	9828-015-001	1
3	Panel-Burner Housing, Top	9454-791-001	1
4	Cover Burner Housing, Top	9074-307-001	1
*	Screw, 10Bx1/4	9545-008-001	4
*	Screw, 10ABx3/8	9545-008-006	23
*	Plate, Recirculation Cover	9452-729-001	1
*	Screw, 10Bx1/4	9545-008-001	6
*	Shield, Burner Inlet	9550-173-001	1
*	Screw, 10ABx3/8	9545-008-024	3
5	Burner, Main	9048-020-001	2
*	Panel- Burner Housing, Back	9454-816-001	1
*	Screw, 10Bx1/4	9545-008-001	4
6	Electrode-Ignition	9875-002-003	1
*	Screw, 8Bx1/4	9545-045-001	2
7	Thermostat-HI-Limit	9576-203-002	1
*	Bracket-Hi-Limit	9029-192-001	1
*	Spacer-Hi-Limit	9538-142-001	2
*	Screw, 8Bx3/4	9545-045-007	2
*	Wire Assy-BRN, 31"	8220-001-415	1
*	Wire Assy-ORG, 31"	8220-095-018	1
*	Thermostat-Over Temp, Manual Reset	9576-207-008	1
*	Screw, 10ABx3/8	9545-008-006	2
*	Bushing, Over Temp	2114-008-000	2
8	Cover Assembly, OverTemp Thermostat	9825-057-002	1
*	Screw, 10ABx3/8	9545-008-006	2
9	Control Assy, Gas Valve	9857-134-001	1
10	Manifold Assy	9381-012-001	1
*	Orifice-Natural, #32	9425-069-009	2
*	Orifice-LP, #50	9425-069-008	2
11	Bracket-Manifold, Gas	9029-257-001	1
12	Bracket-Manifold, Gas	9029-258-001	1
*	Screws,	9545-008-006	4
13	Duct Assy, Recirculation	9973-033-001	1
13	Valve-Gas Shutoff, (Optional)	9379-196-001	1
14	Plug, Manifold		1

1



6

2

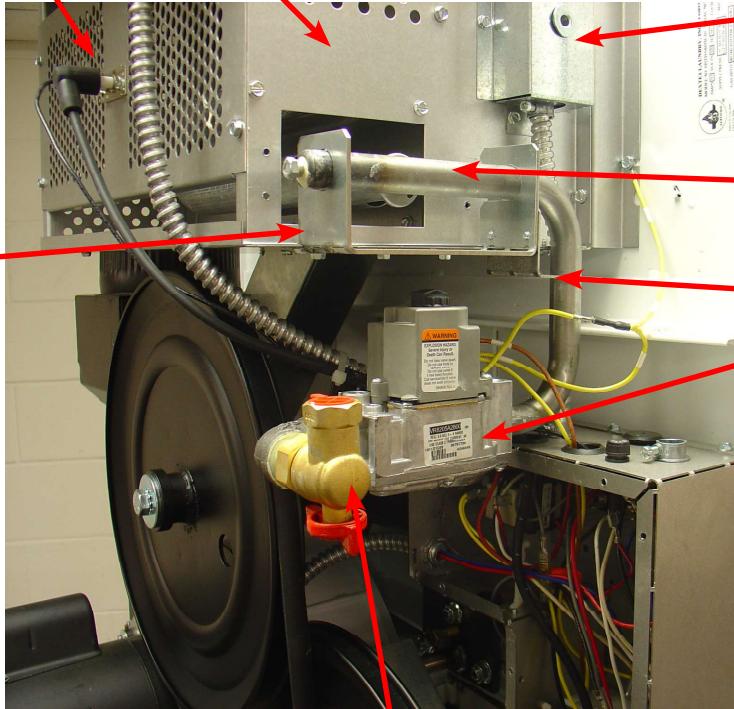

8

10

12

9

11

4

14

3

6

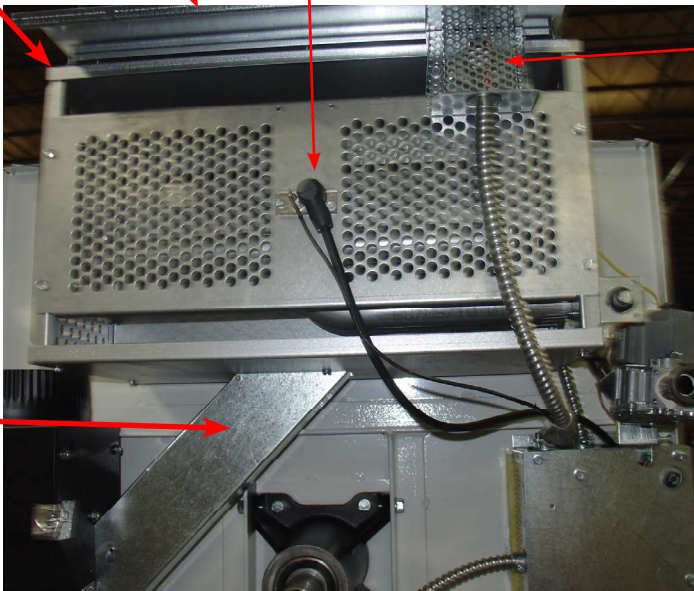

7

13

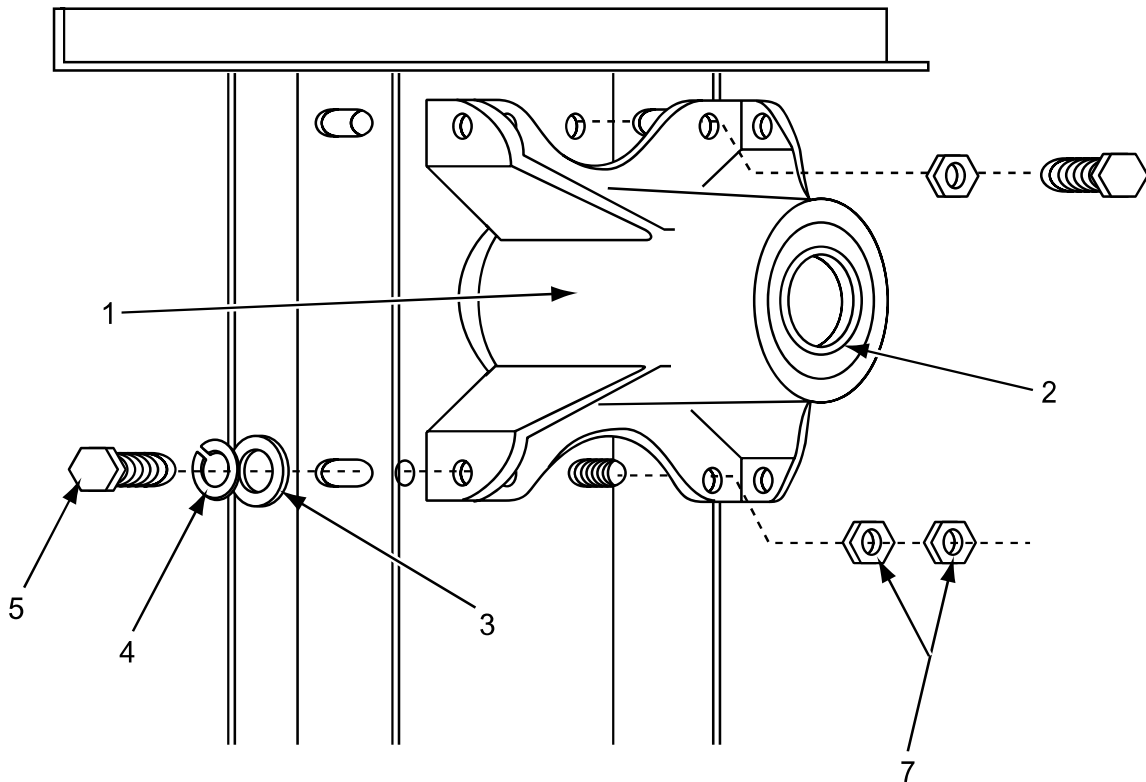

Bearing Housing Assembly

Key	Description	Part Number	Qty
1	Housing, Bearing	9241-161-002	1
2	Bearing, Ball (Front & Rear)	9036-130-001	2
3	Washer, Flat 3/8	8641-581-009	4
4	Lock Washer Spring, 3/8	8641-582-003	4
5	Screw, 3/8-24x3/4	9545-049-002	4
6	Nut, 3/8-24	8640-415-002	2
7	Screw, 3/8-24x1	9545-049-001	2
8	Nut, 5/16-24	8640-400-002	4
*	Spacer, Bearing	9538-139-002	1
*	Shim, Tumbler	9552-013-003	4
*	Bearing Housing Complete Assy (Includes bearings & Spacer)	9803-160-003	1

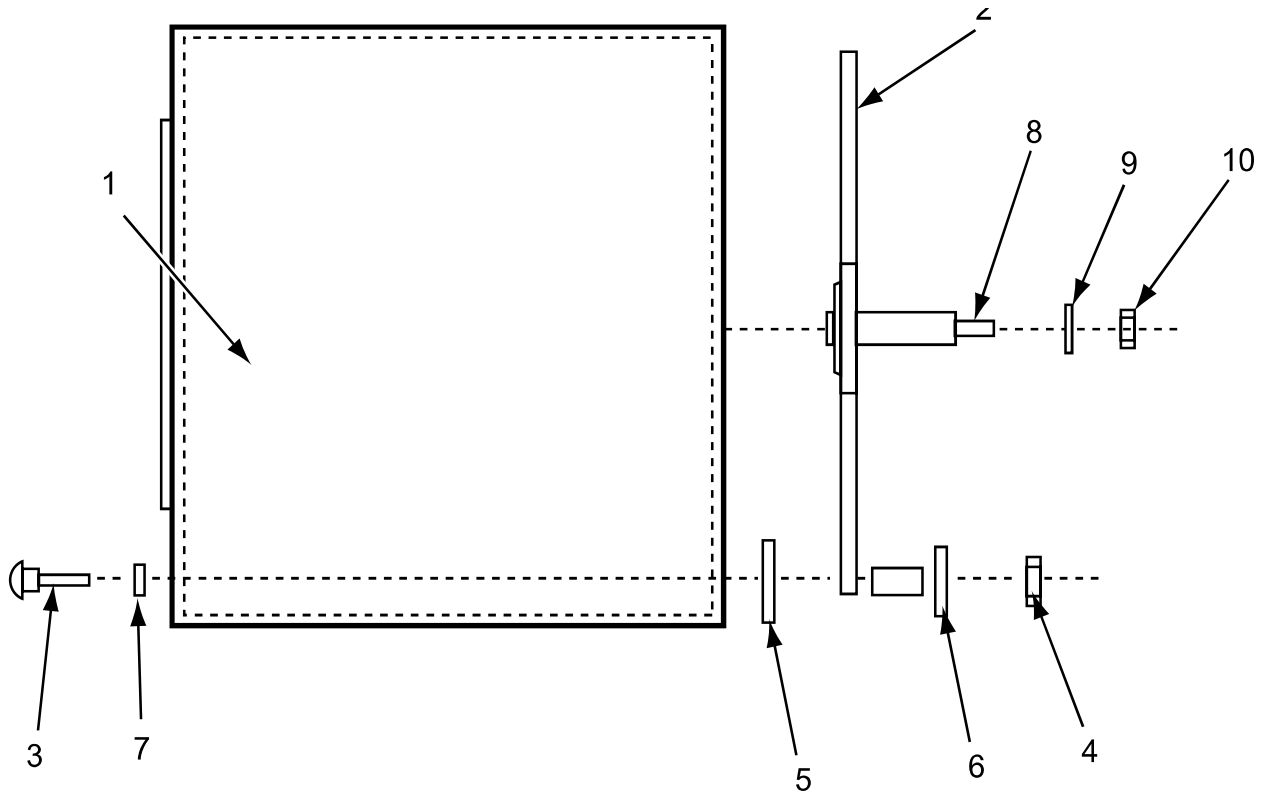

Spyder Trunion & Cylinder

Key	Description	Part Number	Qty
*	Tumbler Assy Complete W/Spider (GALV)	9848-127-001	1
1	Tumbler Assy (Galvanized)	9848-126-001	1
1	Tumbler Assy Complete W/Spider (SS)	9848-127-002	1
1	Tumbler Assy (Stainless)	9848-126-002	1
2	Spider Assy	9568-011-001	1
3	Rod, Tumbler	9497-019-003	3
4	Nut, Wiz Lock	8640-415-004	3
6	Shim	9552-013-000	AR
7	Washer, Special	8641-554-001	3
8	Key- Woodruff	9306-006-000	1
9	LockWasher - IntTooth, 1"	8641-582-015	1
10	Washer -Flat	8641-581-035	1
11	Nut-Hex, 1" -14	8640-222-000	1

Dryer Rear View-Bearing Housing 30Lb

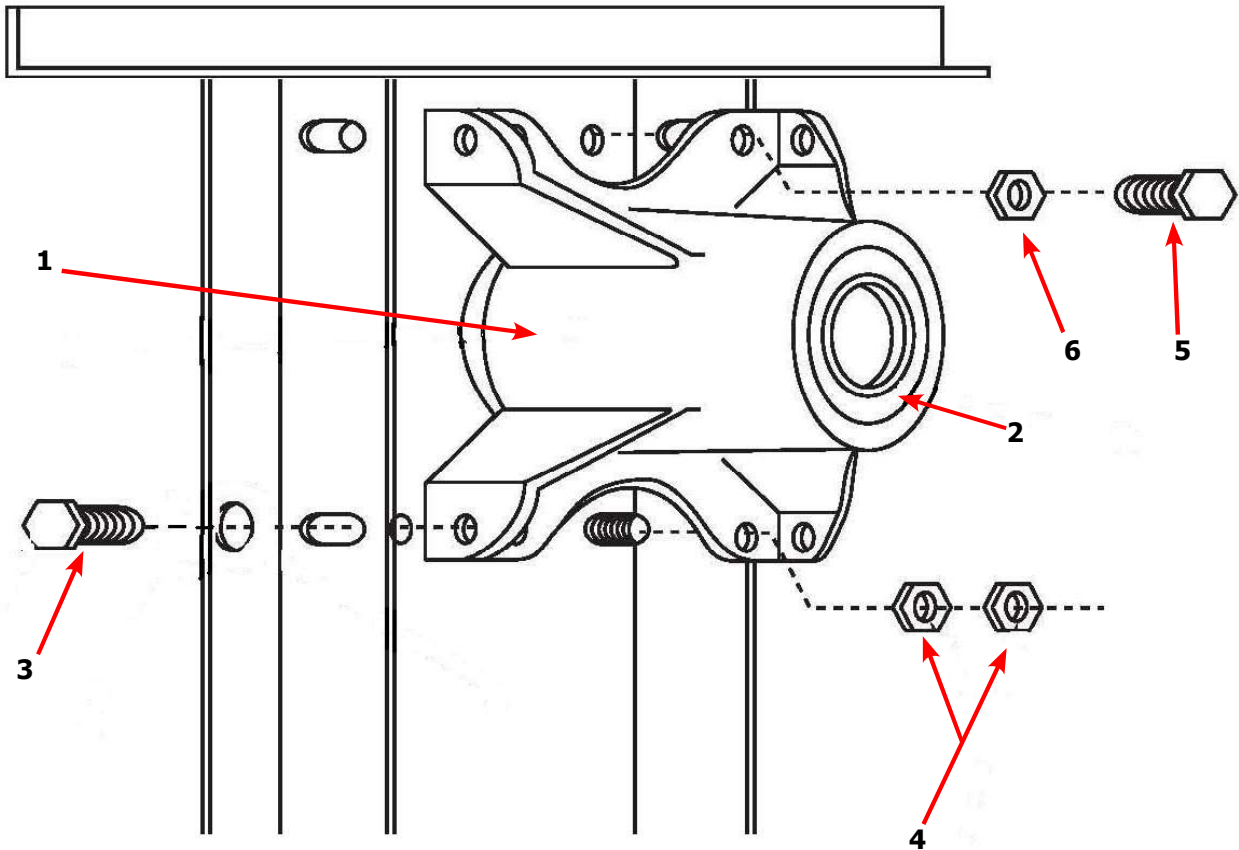

Key	Description	T-30	QTY
*	Bearing Housing Complete Assy (Includes bearings & Spacer)	9803-160-003	1
1	Housing, Bearing	9241-161-002	1
*	Bearing, Ball, Front	9036-130-001	1
*	Spacer, Bearing	9538-139-002	1
2	Bearing, Ball, Rear	9036-130-001	1
3	Screw-Wizlock, 3/8-24x3/4	9545-049-002	4
4	Nut, 5/16-18	8640-400-002	4
5	Screw, 3/8-24x1	9545-049-001	2
6	Nut, 3/8-24	8640-415-002	2
*	Shim, Tumbler	9538-139-002	AR

Dryer Tumbler Group 30Lb

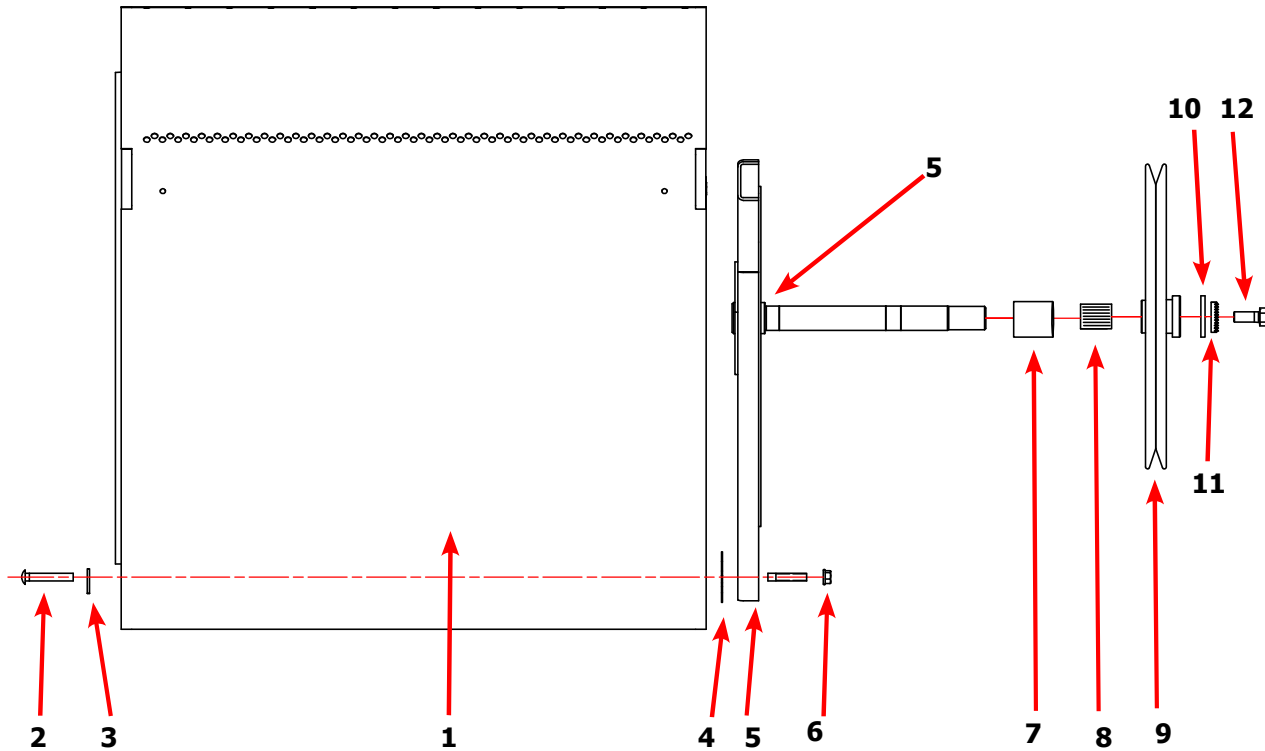

Key	Description	T-30	QTY
*	Tumbler Assy Complete W/Spider (GALV)	9848-142-001	1
1	Tumbler Assy (Galvanized)	9848-126-001	1
1	Tumbler Assy Complete W/Spider (SS & Galv front)	9848-142-002	1
1	Tumbler Assy (Stainless Galvanized front)	9848-126-002	1
2	Rod, Tumbler	9497-019-003	4
3	Washer, Special	8641-554-001	4
4	Shim	9552-013-003	AR
5	Spider Assy	9568-015-001	1
6	Nut, Wiz Lock	8640-415-004	3
7	Spacer-Shaft	9538-164-001	1
8	Tolerance Ring	9487-234-005	1
9	Pulley, Driven	9908-049-002	1
10	Washer -Flat	8641-581-026	1
11	LockWasher - IntTooth, 1"	8641-582-016	1
12	Screw, 1/2-13x1 1/4	9545-017-009	1

Dryer Rear View

Key	Description	Part Number	Qty
1	Motor, Drive	9376-309-001	1
2	Plate, Motor Mounting	9452-766-001	1
*	Screw-Hex, 3/8-16x3/4	9545-029-008	4
*	Screw, Motor to Plate to Housing Back	9545-018-019	5
*	Lock Washer	8641-582-007	5
*	Spacer	9538-163-006	5
*	Flat Washer	8641-581-017	15
*	Rubber Grommet	9209-086-002	5
*	Grommet Spacers, Metal	9538-166-006	5
*	Pulley, Motor	9453-157-001	1
*	Screw, Set Motor Pulley	9545-028-013	2
3	Back Assy, Blower Housing	9962-015-002	1
*	Impeller, W/Set Screws	9278-039-001	2
4	Belt, Drive Motor	9040-073-009	1
5	Belt, Driven-Tumbler	9040-077-001	1
6	Pulley, Driven	9908-040-001	1
*	Key- Woodruff	9306-006-000	1
*	6" Slide Open Clean Out Duct (Optional)	9973-035-001	1

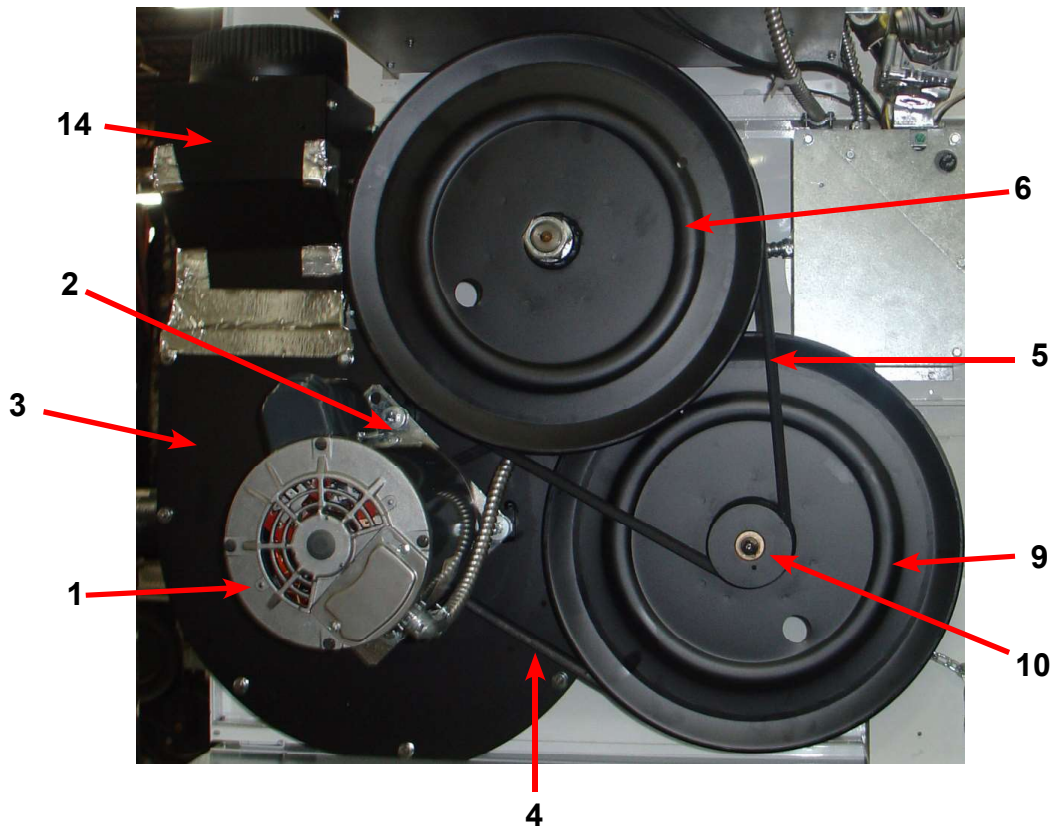

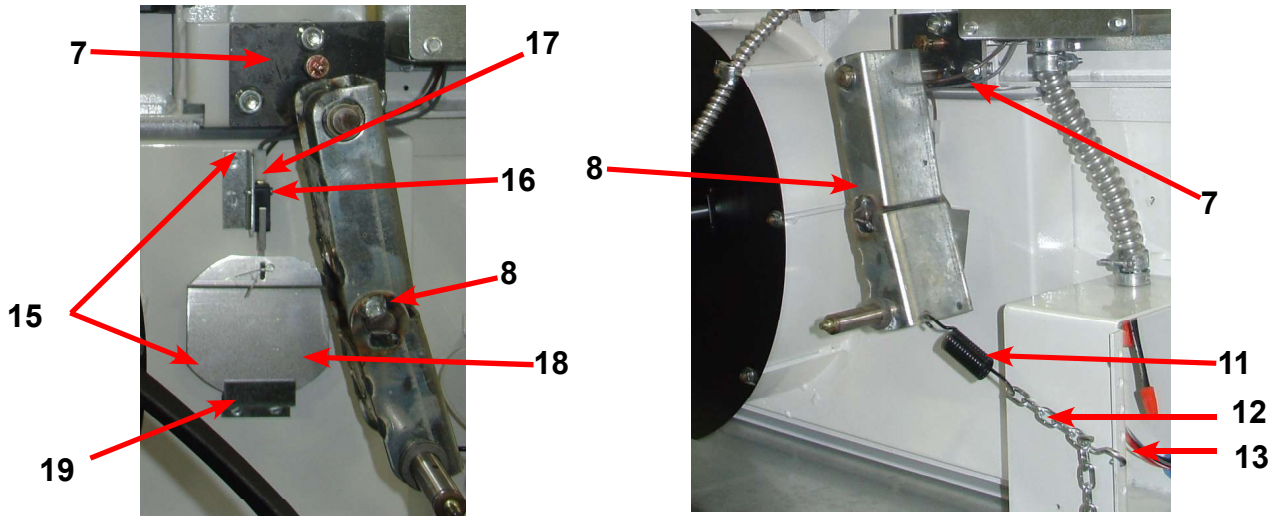

Key	Description	Part Number	Qty
7	Support Assy, Intermediate Pulley	9991-053-001	1
*	Bolt, Rd Hd 3/8-16x1 1/4	9545-029-010	3
*	Bolt 3/8-16x 1 1/2	9545-029-003	1
*	Nut	8640-415-004	3
*	Washer Flat	8641-581-035	4
8	Arm Assy-Tension, Complete	9861-022-001	1
*	Washer Flat	8641-581-035	3
*	Ring-Retaining	9487-200-003	3
9	Pulley Assy, Intermediate	9908-039-004	1
10	Bushing, Bronze	9036-145-002	2
*	Spacer, Shaft	9538-164-001	1
*	LockWasher - IntTooth, 1"	8641-582-015	1
*	Washer -Flat	8641-581-035	1
*	Nut-Hex, 1" -14	8640-222-000	1
11	Spring, Tension	9534-319-002	1
12	Chain, Tension	9099-012-002	1
13	Hook, Tension	9248-022-002	1
14	Housing-Assy, Damper	9803-184-002	1
*	Damper	9125-003-001	1
*	Pin, Hinge Damper	9451-146-004	2
*	Nut, Spring	8520-141-000	4
15	Switch Assembly, Air Flow	9801-060-001	1
16	Switch, Air Flow	9539-461-009	1
17	Bracket, Switch-Air Flow	9029-044-001	1
18	Acuator, Switch	9008-007-001	1
*	Pin, Cotter	9451-169-002	1
*	Screw	9545-020-001	2
*	Nut, Special Twin	8640-401-001	1
*	Shield, Switch	9550-169-003	1
19	Bracket, Actuator Stop	9029-046-001	1
*	Screw	9545-008-024	4

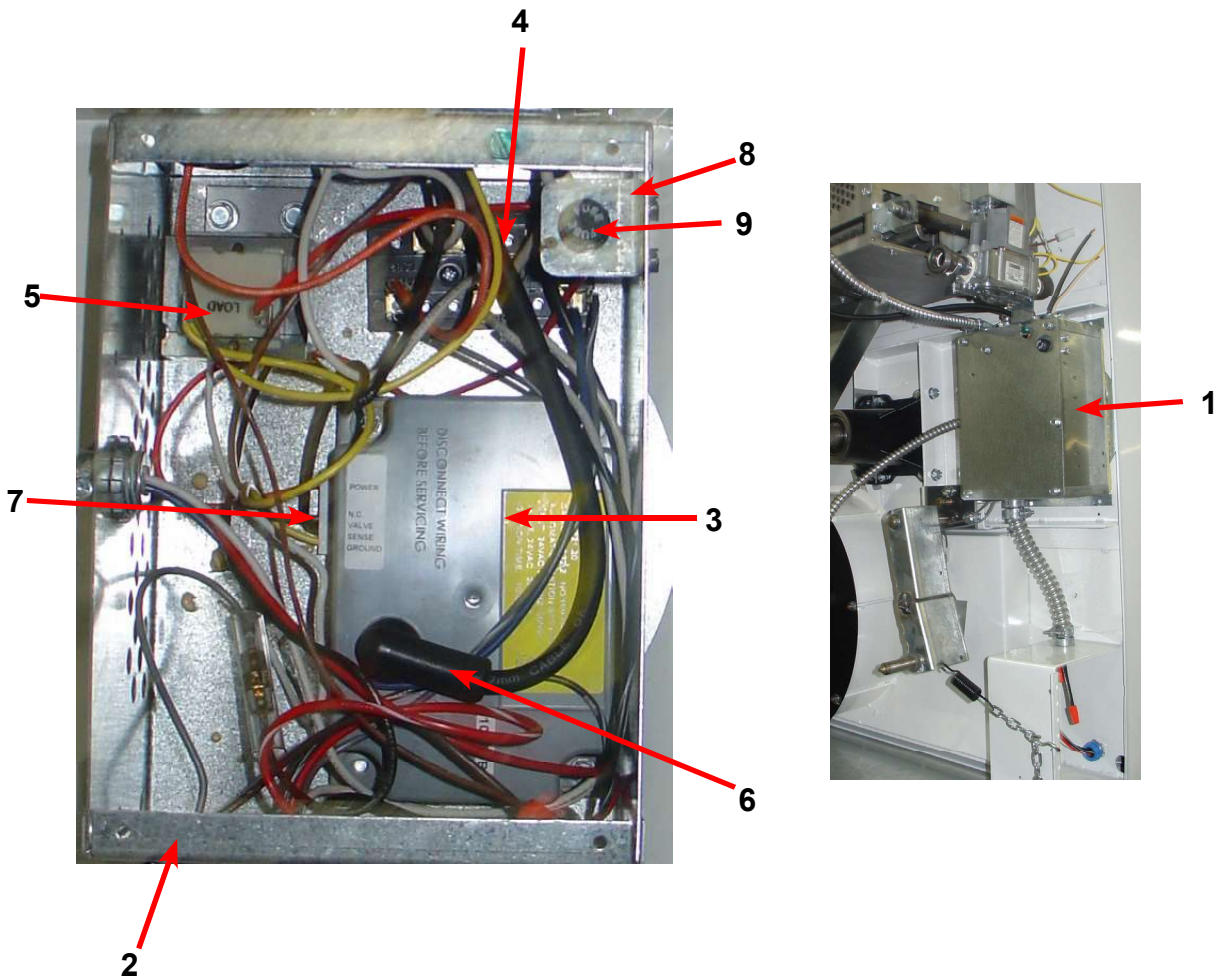

Electrical Box / Ignition Control Before S/N 232998

Key	Description	Part Number	Qty
1	Control Assembly-Ignition, Complete (2-9 included)	9857-128-001	1
2	Box- Ignition Control	9807-079-001	1
3	Control, Ignition	9857-116-003	1
4	Terminal Block-Power	9897-026-001	1
5	Transformer 120/24VAC	8711-011-001	1
6	Wire Assy- Hi Voltage	9631-403-002	1
7	Harness- Low Voltage	9627-678-001	1
*	Wire Assy-Red, 9"	8220-001-225	1
8	Bracket Fuse Holder	9029-048-001	1
9	Fuse Holder	9200-001-002	1
*	Fuse, 1.5 Amp	8636-018-001	1
*	Insulation, Electrical Box (back)	9277-041-013	1

Electrical Box / Ignition Control Before S/N 232998

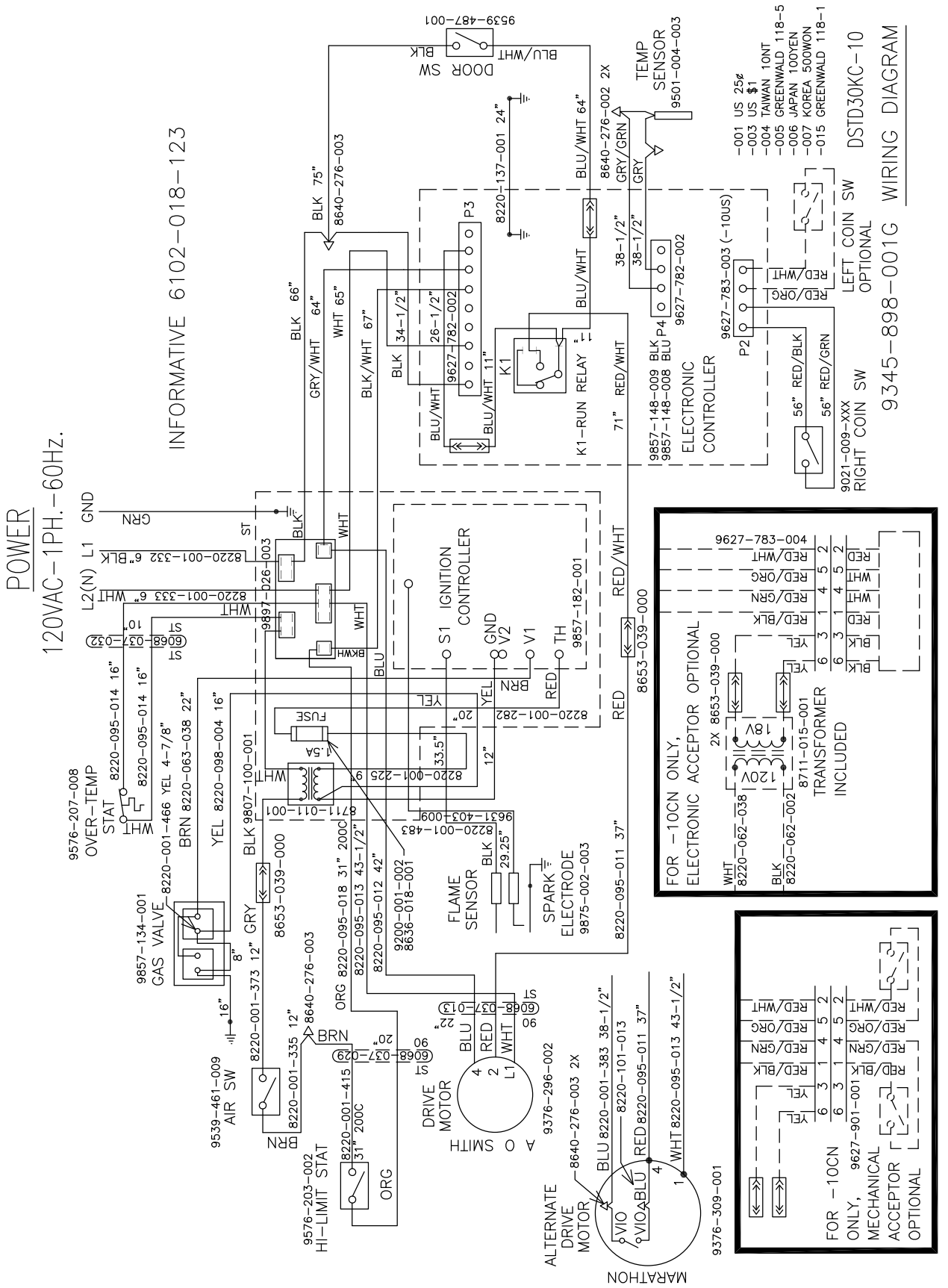

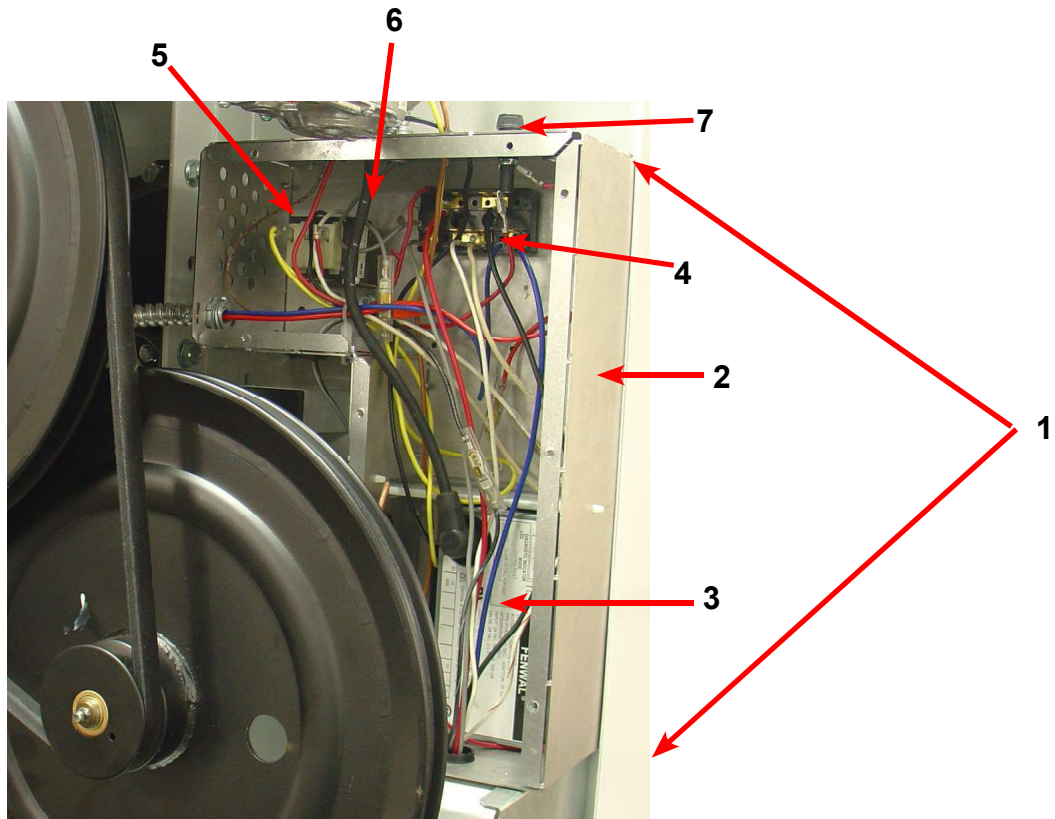

Electrical Box / Ignition Control After S/N 232998

Key	Description	Part Number	Qty
1	Control Assembly-Ignition, Complete (2-9 included)	9857-128-021	1
2	Box- Ignition Control	9807-109-001	1
3	Control, Ignition	9857-182-001	1
4	Terminal Block-Power	9897-026-003	1
5	Transformer 120/24VAC	8711-011-001	1
*	Wire Assy-Red, 9"	8220-001-225	1
6	Wire Assy- Hi Voltage	9631-403-009	1
7	Fuse Holder	9200-001-002	1
*	Fuse, 1.5 Amp	8636-018-001	1
*	Insulation, Electrical Box (back)	9277-041-013	1

Electrical Box / Ignition Control After S/N 232998

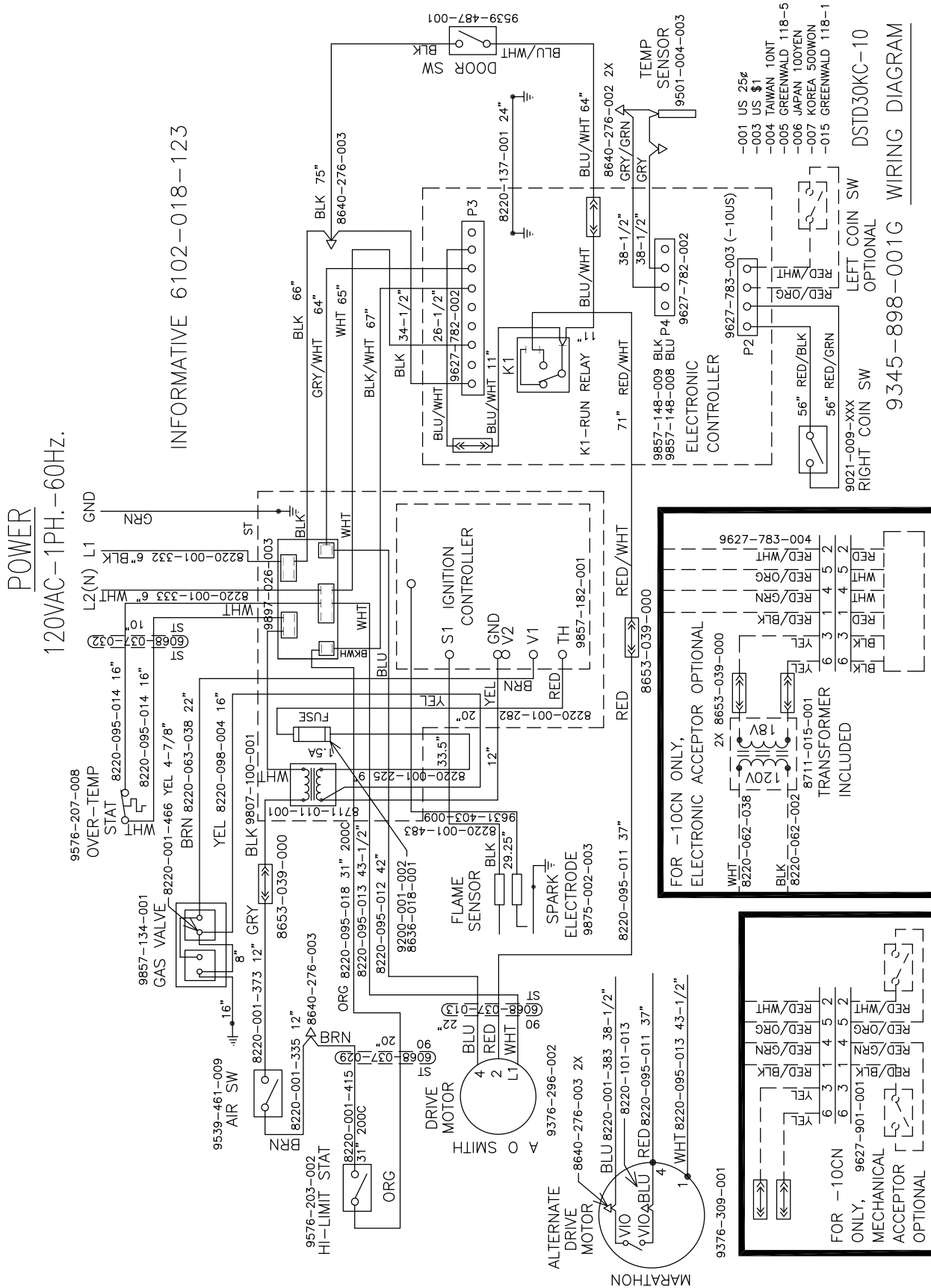

Coin Handling Group

Key	Description	Part Number	Qty
	Harness, Main	9627-782-001	1
*	Harness, Coin Switch	9627-783-001	1
*	Harness, Low Voltage	9627-678-001	1
*	Transformer, 120V/24V	8711-011-001	1
*	Terminal Block	9897-026-001	1
*	Hi Voltage Lead	9631-403-002	1
*	Diagram, Wiring	9345-898-001	1
*	Schematic, Wiring	9345-897-001	1
9	Acceptor, Micro Switch	9021-009-001	1
9	Switch, Coin	9539-466-005	1
*	Acceptor Chute Assy w/o penny rejector	9119-025-002	1
8	(optional) Acceptor Chute Assy w/ penny rejector	9119-025-001	1
*	Retainer, Coin Acceptor	9486-145-001	1
*	Screw, Torx	9545-053-002	4
*	Screw-Height Bar, 3mm	9545-039-002	2

Coin Handling Group

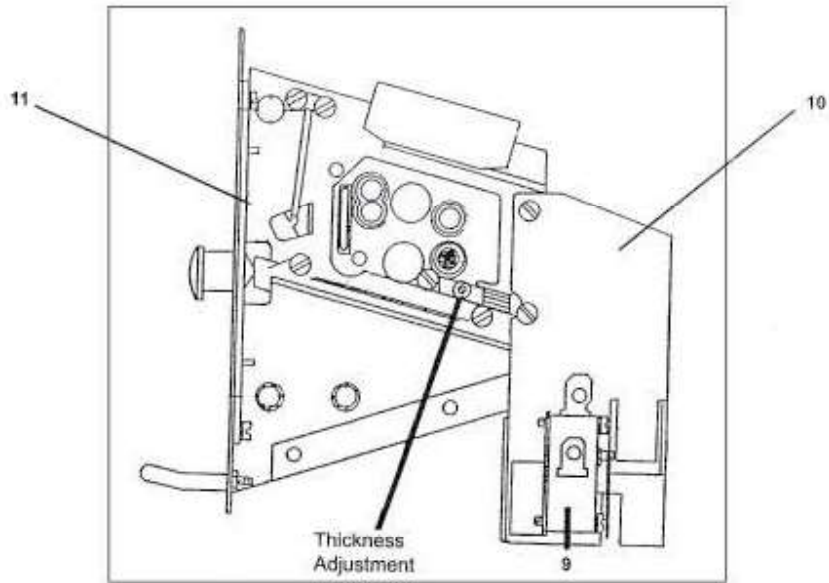

#8 COIN ACCEPTOR - right side

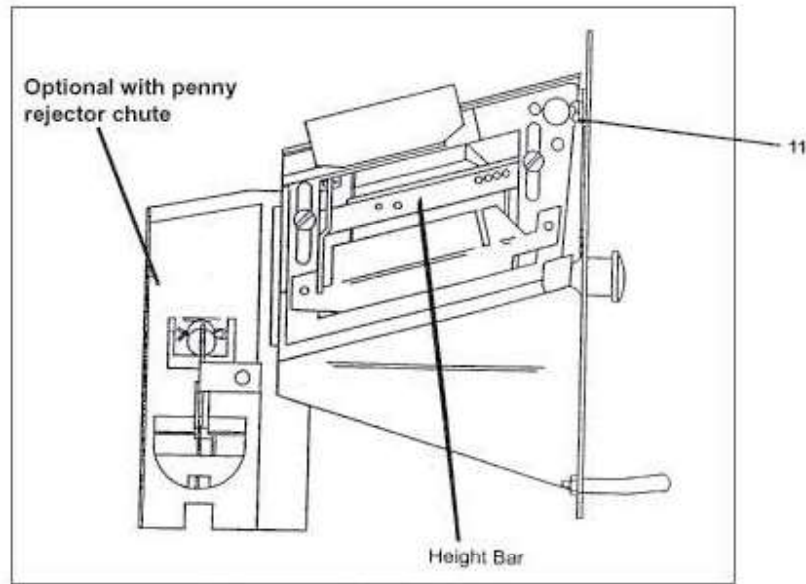

#8 COIN ACCEPTOR - left side

Dryer EasyCard Group

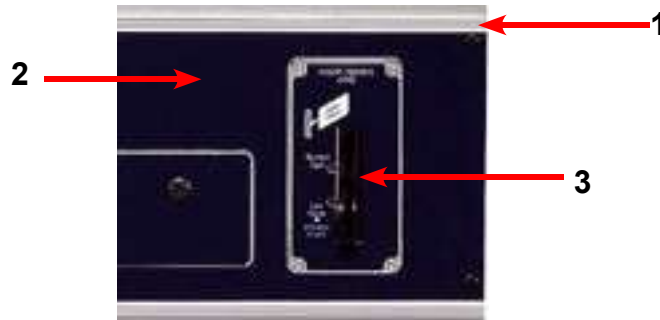

Key	Description	Part Number	Qty
	Panel-Front, Stack Washer Dryer, Dryer	9454-509-001	1
	Escutchen-Upper	9141-152-001	1
	Overlay-Escutcheon	9435-018-002	1
	Harness-Reader	9627-731-001	1
	Reader, Simple (Reader only no Face Plate)	9797-006-003	1
	Cable Cat5, 20' s/s	9806-013-003	1
	Lable, EasyCard Instructions	8502-729-001	1
	Schematic	9506-148-001	1
	Diagram	9506-149-001	1

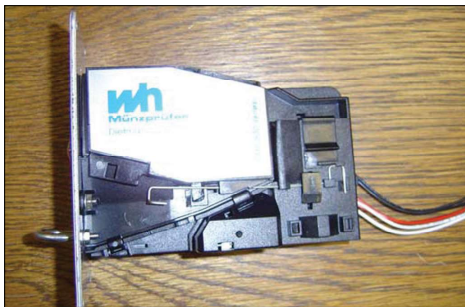

Key	Description	Part Number	Qty
	Acceptor-Electronic	9021-012-001	1
	Transformer, 120/24VAC	8711-015-001	1
	Harness, Door Coin Switch	9627-783-002	1
	Wire Jumper, BLK	8220-133-001	1
	Wire Jumper, WHT	8220-133-002	1
	Lable-Wiring, Electronic Acceptor	8502-730-001	1
	Connector, Inline, 1/4	8653-039-000	6
	Retainer Coin Acceptor, Electronic	9486-155-001	2

Section 6:

Electric Heated
Dryer:
Wiring Diagram
and Parts Data

Wiring Schematic for Electric Dryer -16FC

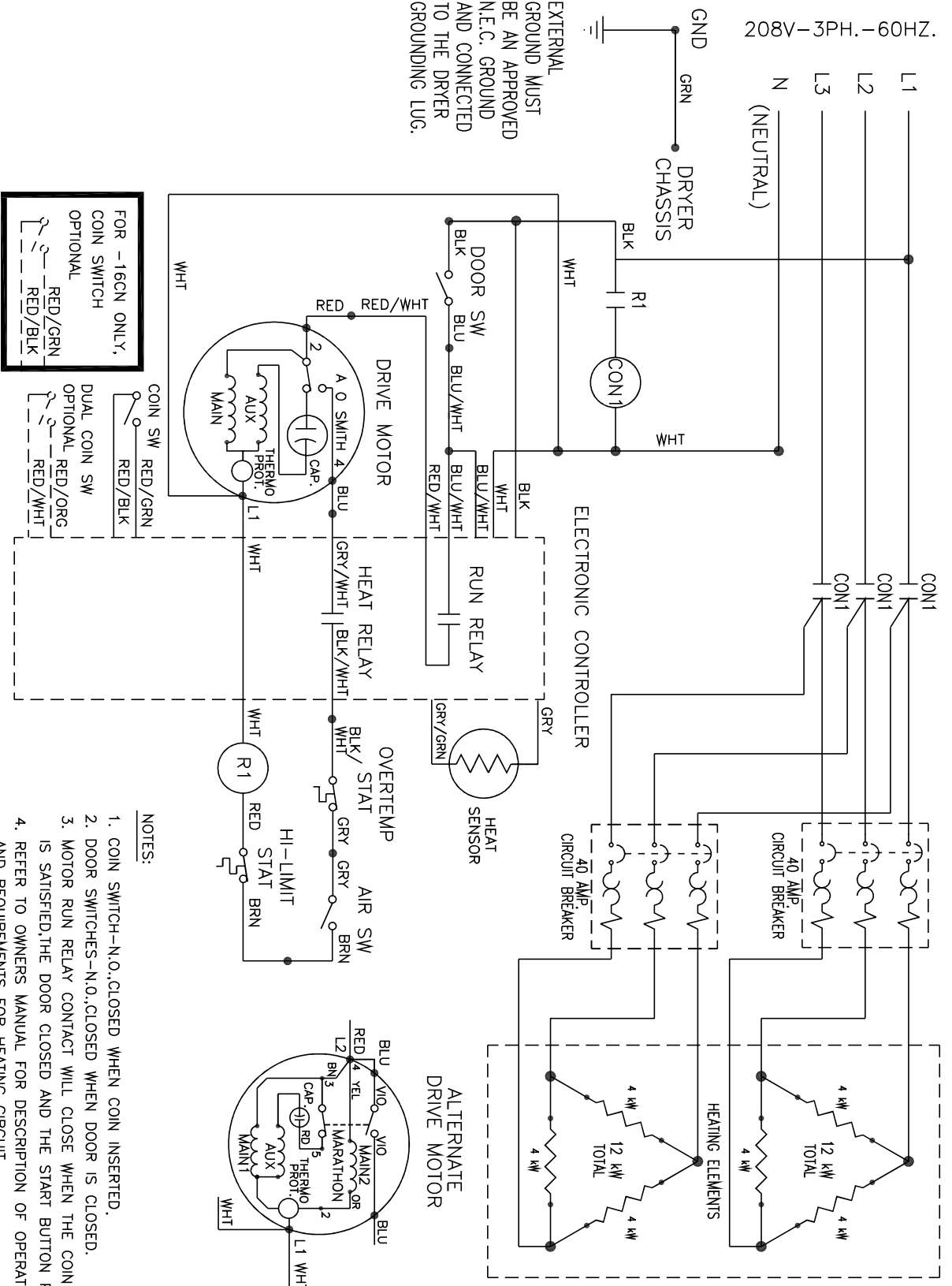

9345-993-001B

SCHEMATIC

D_T_30KC_16FC

- NOTES:
1. COIN SWITCH-N.O.CLOSED WHEN COIN INSERTED.
 2. DOOR SWITCHES-N.O.CLOSED WHEN DOOR IS CLOSED.
 3. MOTOR RUN RELAY CONTACT WILL CLOSE WHEN THE COIN COUNT IS SATISFIED,THE DOOR CLOSED AND THE START BUTTON PRESSED.
 4. REFER TO OWNERS MANUAL FOR DESCRIPTION OF OPERATION AND REQUIREMENTS FOR HEATING CIRCUIT.

Wiring Diagram for Electric Dryer -16FC

9345-994-001B

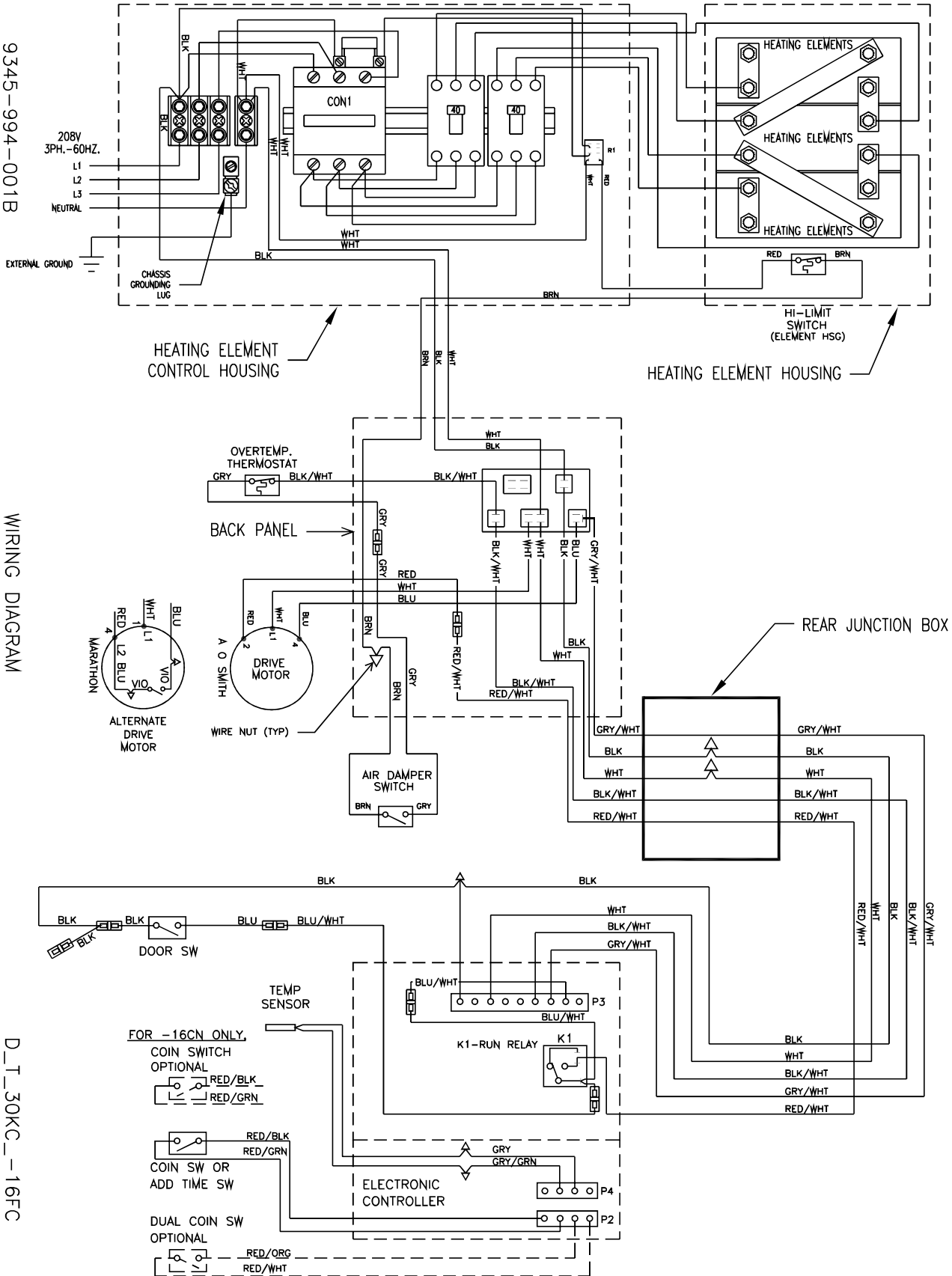

WIRING DIAGRAM

D_T_30KC_16FC

Wiring Schematic for Electric Dryer -60FA

9506-214-001B

SCHEMATIC

D_T_30KC_60FA

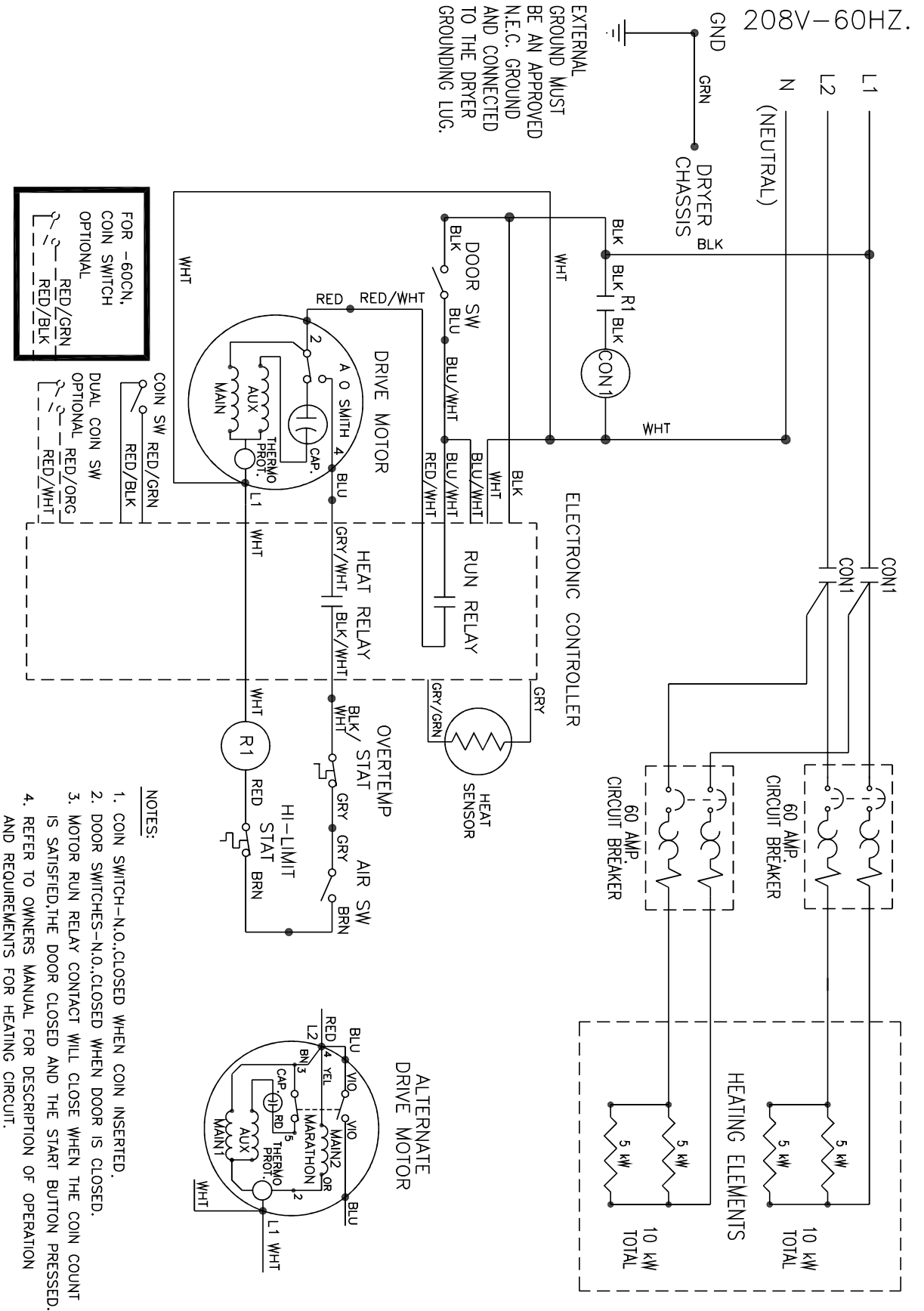

Wiring Diagram for Electric Dryer -60FA

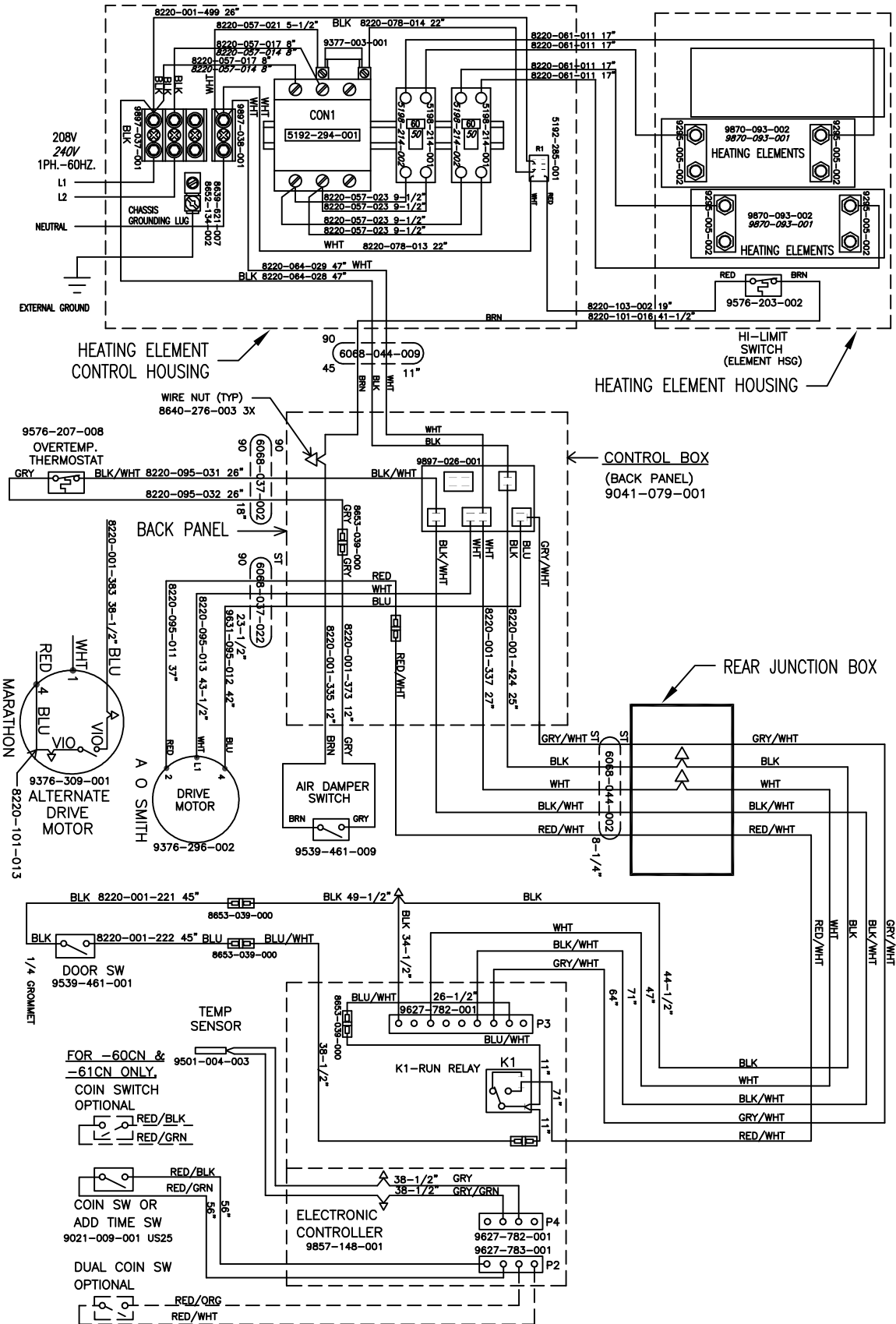

9506-215-001B
9506-XXX-001

INFORMATIVE 9506-018-102
WIRING DIAGRAM

DSTD30KC_-60FA
DSTD30KC_-61FB

Wiring Schematic for Electric Dryer -62FL

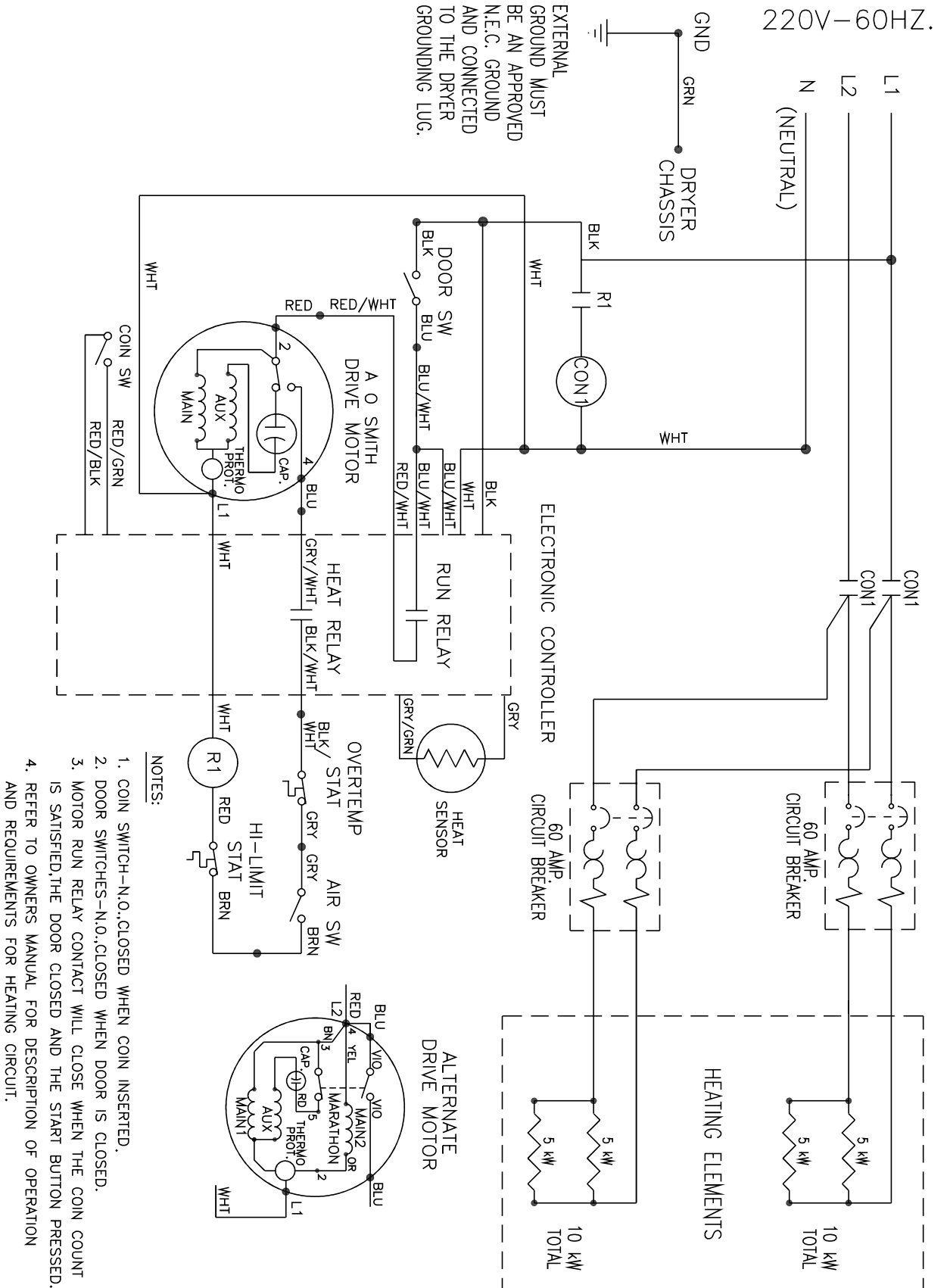

9345-987-002A

SCHEMATIC

D_T_30KC_62FL

Wiring Diagram for Electric Dryer -62FL

9345-988-002A

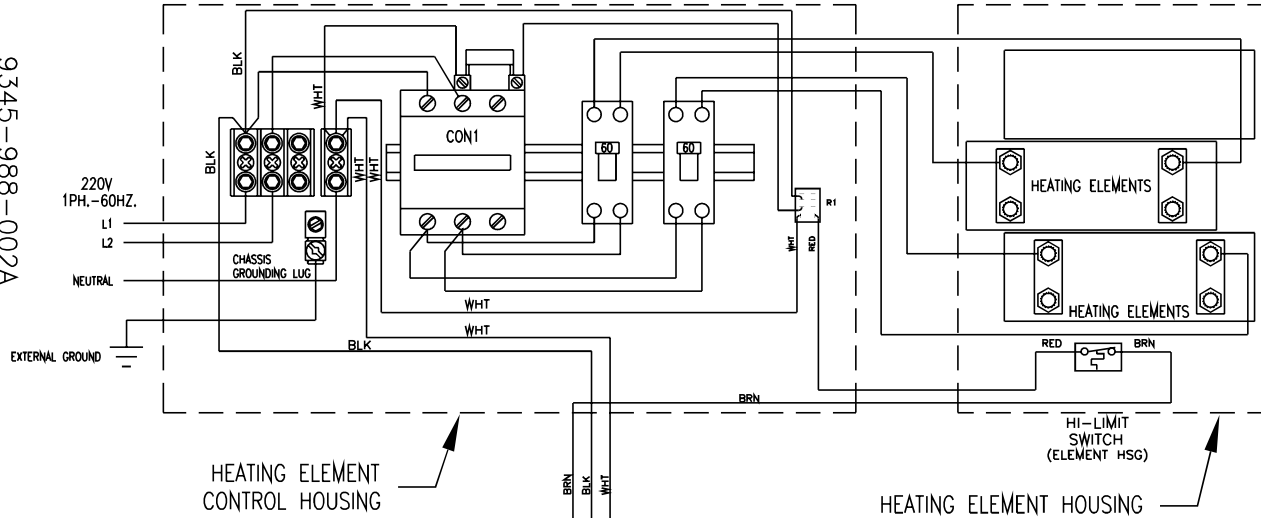

HEATING ELEMENT CONTROL HOUSING

HEATING ELEMENT HOUSING

WIRING DIAGRAM

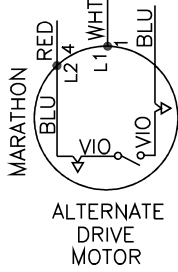

ALTERNATE DRIVE MOTOR

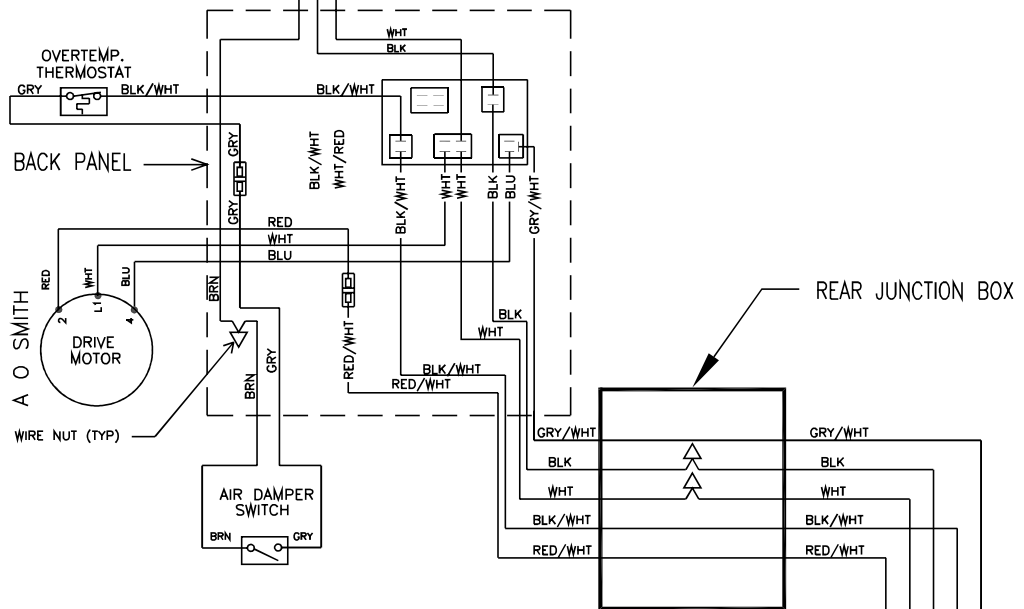

BACK PANEL

REAR JUNCTION BOX

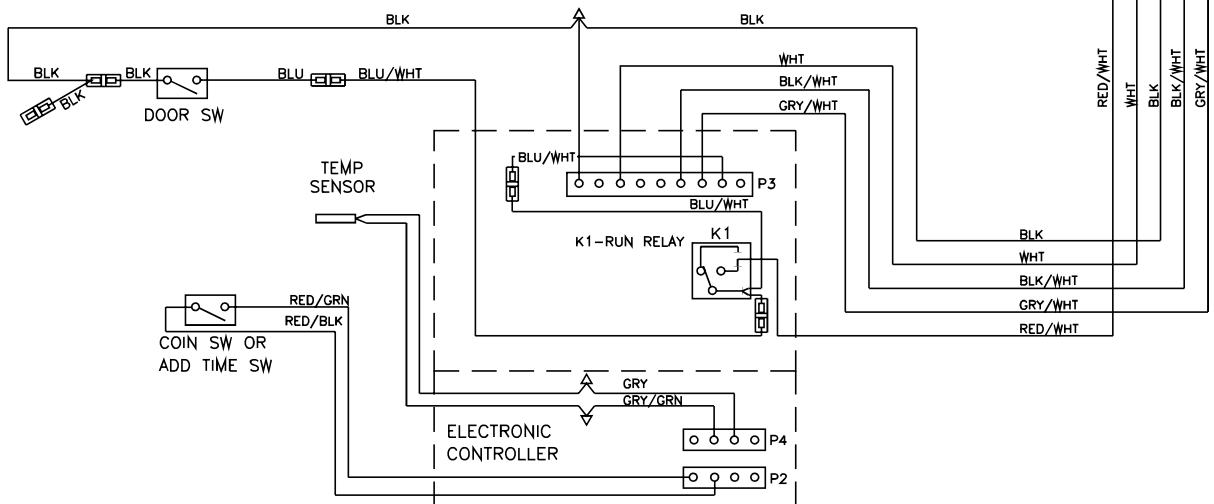

TEMP SENSOR

K1-RUN RELAY

COIN SW OR
ADD TIME SW

ELECTRONIC
CONTROLLER

D_T_30KC_62FL

Wiring Schematic for Electric Dryer -66FW

9506-208-001A

SCHEMATIC

DST_30KC_66FW

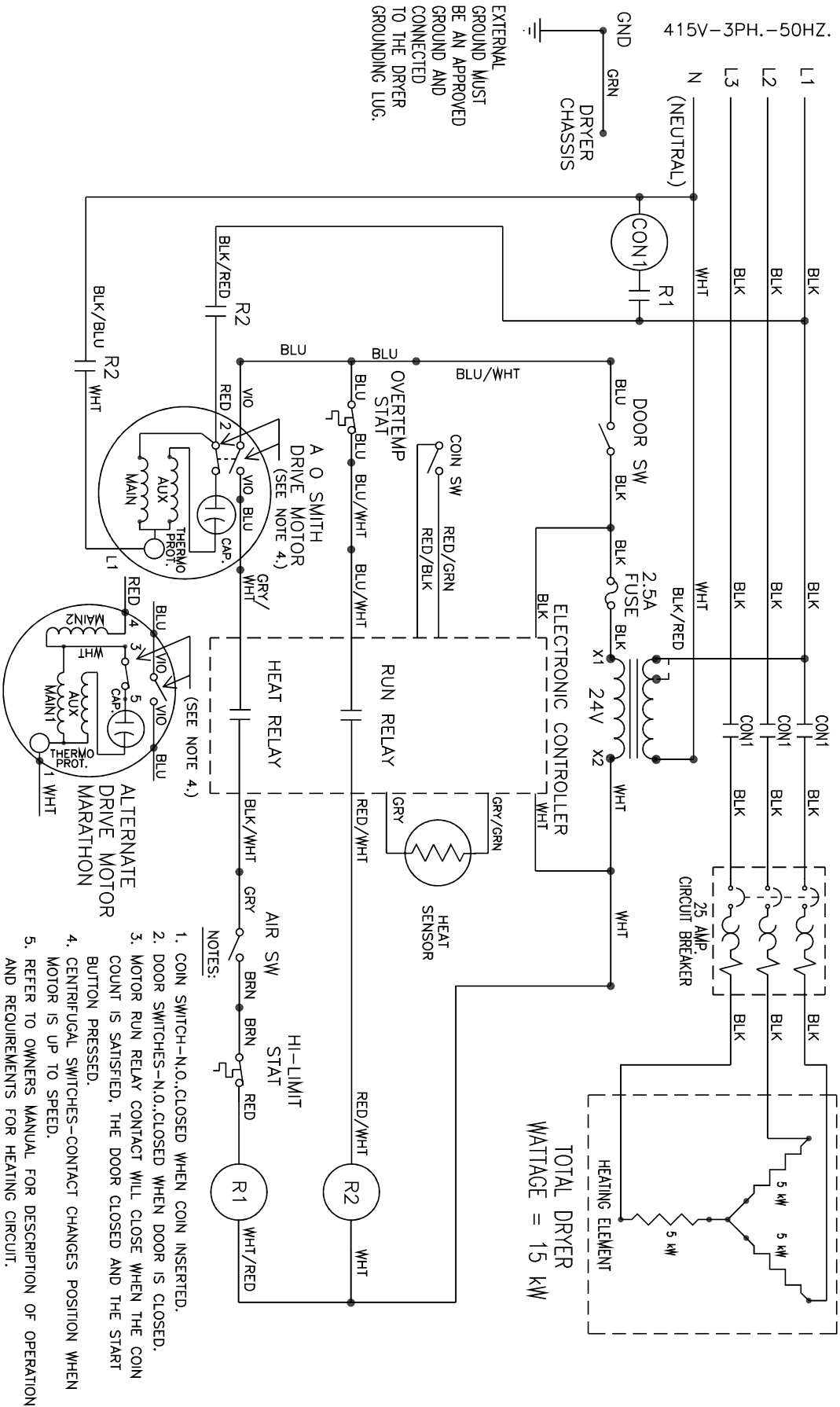

Wiring Diagram for Electric Dryer -66FW

9506-209-001A

WIRING DIAGRAM

DST_30KC_--66FW

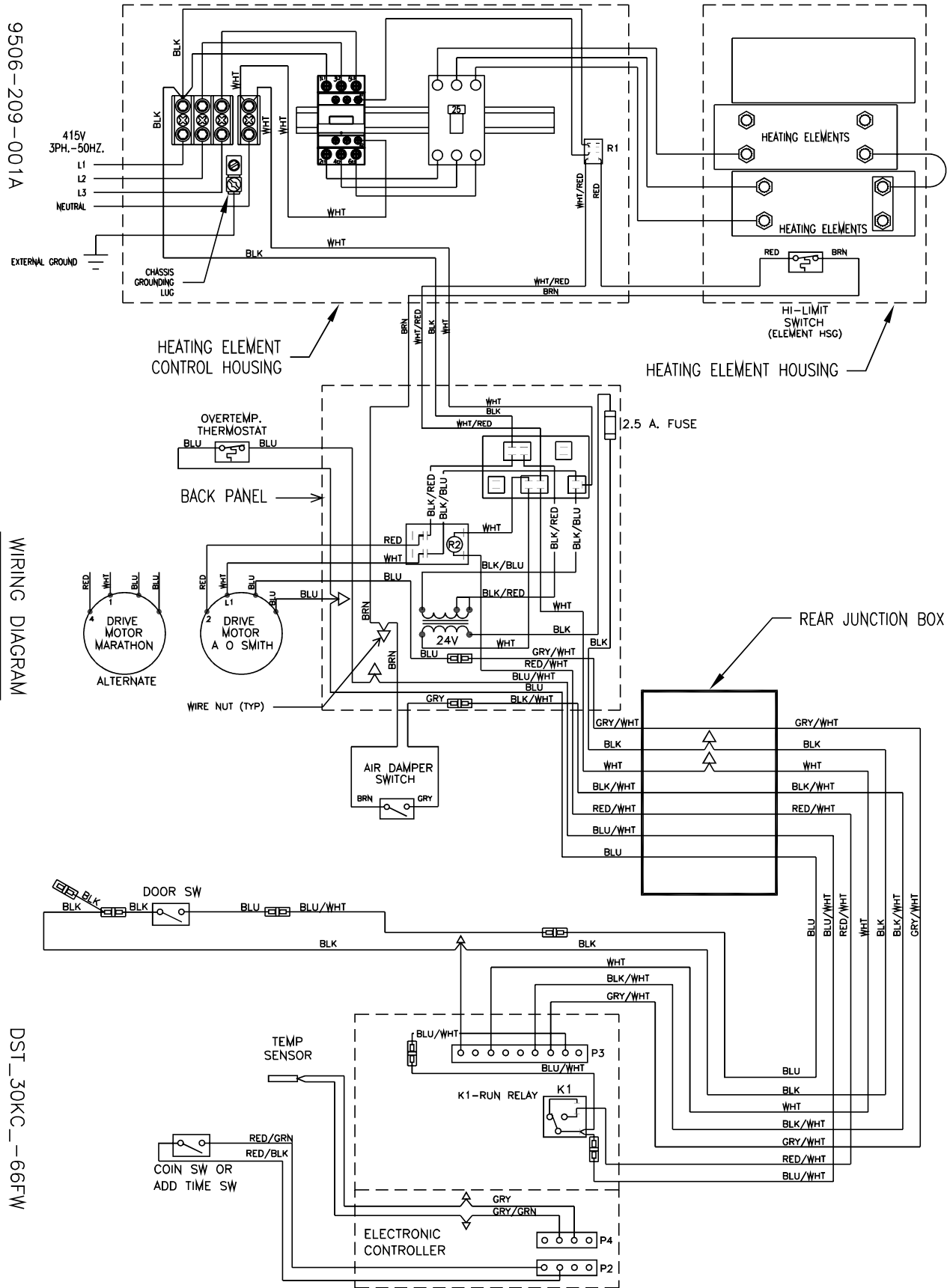

SWD Dryer Electric Heated DSTD30KC_-16FC

Key	Description	Part Number	Qty
*	COVER-HOUSING,CONTROL	9074-292-001	1
*	FILLER-COVER,TERMINAL	9185-007-001	1
*	VARISTOR-COILSUPPRESSOR	9377-003-001	1
*	CAP-ACTUATOR	0935-133-001	1
*	RAIL-DIN,35X15MM	9488-011-002	1
*	SIDE-HOUSING,CONTROL(RH)	9551-030-001	1
*	SIDE-HOUSING,CONTROL(LH)	9551-031-001	1
*	SIDE-HOUSING,HEATER(RIGHTHAND)	9551-032-001	1
*	SIDE-HOUSING,HEATER(LEFTHAND)	9551-033-001	1
*	WRAPPER-HOUSING,CONTROL	9636-154-001	1
*	WRAPPER-HOUSING,HEATER	9636-155-001	1
1	BLOCK-POWER,3POLE	9897-037-001	1
1	BLOCK-POWER,1POLE	9897-038-001	1
*	LABEL-WARNING,HIGHVOLTAGE	8502-614-005	1
*	LABEL-WARNING	8502-639-001	1
*	LABEL-WARN,FIREHAZARD(FRENCH)	8502-702-001	1
*	LABEL-EXHAUSTWARNING	8502-708-001	2
*	LABEL-WARNINGFOR208V	8502-711-001	1
*	BOOKLET-OWNERS,SWD	8514-046-002	1
3	WIRINGLABEL-SCHEMATIC	9345-993-001	1
3	WIRINGLABEL-SCHEMATIC	9345-993-002	1
3	WIRINGLABEL-DIAGRAM	9345-994-001	1
3	WIRINGLABEL-DIAGRAM	9345-994-002	1
*	BRACKET-THERMOSTATMOUNTING	9029-136-001	1
*	BOTTOM-HOUSING,HEATER	9058-026-001	1
*	COVER-PLATE,HEATER	9074-293-001	1
*	COVER-TERMINAL,HEATER	9074-294-001	1
*	DEFLECTOR-BOTTOM,HOUSING	9114-044-001	1
*	DEFLECTOR-WRAPPER,HOUSING	9114-045-001	1
*	JUMPER-FORMED	9295-004-002	2
*	JUMPER-STRAIGHT	9295-005-002	4
*	BAFFLEASSEMBLY-HOUSING,HEATER	9812-014-001	1
*	HEATER-ELECTRICELEMENT	9870-093-004	3

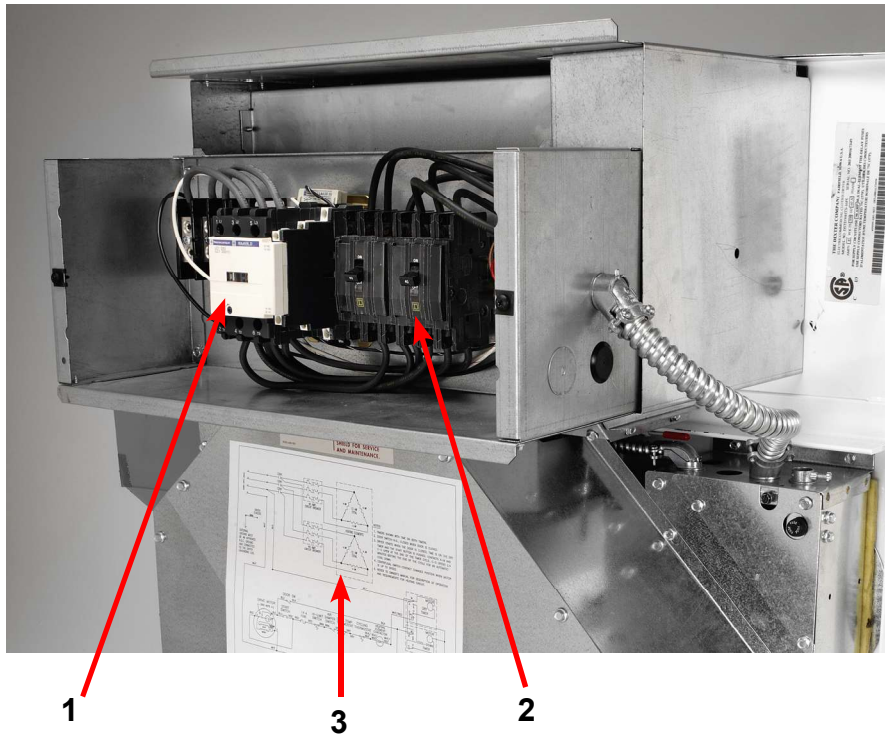

1

3

2

SWD Dryer Electric Heated DATD30KC_-62FL

Key	Description	Part Number	Qty
3	WIRINGLABEL-SCHEMATIC	9345-987-002	1
3	WIRINGLABEL-DIAGRAM	9345-988-002	1
	HEATER-ELECTRICELEMENT	9870-093-005	2
1	RELAY-125AMP(REISTIVE)CONTACT	5192-294-001	1
2	CIRCUITBREAKER-2POLE	5198-214-001	2

SWD DRYER Electric Heated DSTD30KC_-60FA

Key	Description	Part Number	Qty
1	RELAY-125AMP(REISTIVE)CONTACT	5192-294-001	1
2	CIRCUITBREAKER-2POLE	5198-214-001	2
3	WIRINGLABEL-SCHEMATIC	9506-214-002	1
3	WIRINGLABEL-DIAGRAM	9506-215-002	1
	HEATER-ELECTRICELEMENT	9870-093-002	2

SWD Dryer Electric Heated DSTD30KC_-66FW

Key	Description	Part Number	Qty
1	RELAY	5192-285-004	1
1	RELAY	5192-288-001	1
	FUSE-2,5A	8636-018-004	1
	BRACKET-FUSEHOLDER	9029-048-001	1
	FUSE HOLDER ASSEMBLY	9200-001-002	1
	TRANSFORMER-CONTROL	8711-008-002	1
	HEATER-ELECTRICELEMENT	9870-093-001	2
	VARISTOR-COILSUPPRESSOR	9377-003-002	1
	JUMPER-STRAIGHT	9295-005-002	1
	MOTOR-DRY,MRTHON(30#STK),50HZ	9376-318-001	1
	CONTROLSASY-ELEC,STKW/D(W/IR)	9857-148-002	1
	PULLEY-DRIVE,MACHINED	9453-169-009	1
3	WIRINGLABEL-SCHEMATIC	9506-208-001	1
31	WIRINGLABEL-DIAGRAM	9506-209-001	1
	DRAWERASY-LINT,UP/LOW(AUSCOIN)	9866-004-009	1
	LABEL-AUSSIEWARNING	8502-698-001	1
	INSTRUCTIONS-AUSSIEADDENDUM	8507-298-001	1

Section 7:

50 Hz Gas Dryer

Key	Description	Part Number	Qty
	FILTER-LINE,EMI	9183-030-001	1
	FILTER-EMI,3A,115/250V	9183-047-001	1
	MOTOR-DRY,MRTHON(30#STK),50HZ	9376-318-001	1
	PULLEY-DRIVE,MACHINED	9453-169-009	1
	CONTROLSASSEMBLY-FENWAL	9857-140-001	1
	CONTROLSASY-ELEC,STKW/D(W/IR)	9857-148-002	1
	TRANSFORMER-CONTROL	8711-008-002	1
	RELAY, Motor Control	5192-288-001	1
	INSTRUCTIONS-TRANSFORMCONNECT	8507-230-003	1
	INSTRUCTIONS-AUSSIEADDENDUM	8507-298-001	1
	LABEL-AUSSIEWARNING	8502-698-001	1
	WIRINGLABEL-SCHEMATIC	9506-168-001	1
	WIRINGLABEL-DIAGRAM	9506-169-001	1

Key	Description	Part Number	Qty
	KIT-HONEYWELLVR86VALVEFLANGE	9732-162-001	2
	CONTROLASSEMBLY-GAS	9857-132-004	1
	Orifice-Natural, #32	9425-069-009	2
	LP Conversion Kit	9732-179-001	1
	Orifice-LP, #50	9425-069-008	2

Wiring Schematic for Dryer 50hz 230V

9506-168-001C

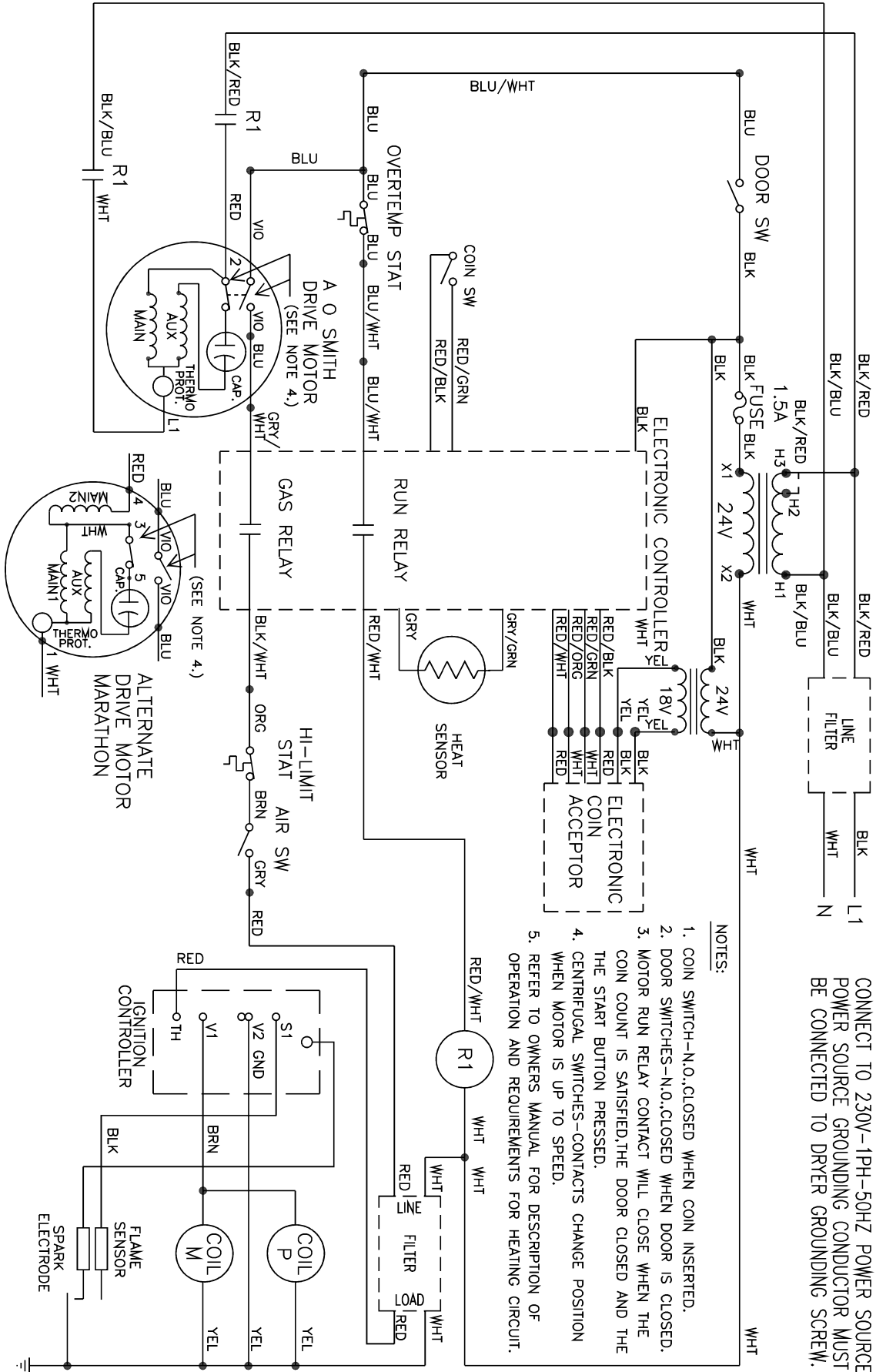

CONNECT TO 230V-1PH-50HZ POWER SOURCE.
POWER SOURCE GROUNDING CONDUCTOR MUST
BE CONNECTED TO DRYER GROUNDING SCREW.

- NOTES:
1. COIN SWITCH-N.O.,CLOSED WHEN COIN INSERTED.
 2. DOOR SWITCHES-N.O.,CLOSED WHEN DOOR IS CLOSED.
 3. MOTOR RUN RELAY CONTACT WILL CLOSE WHEN THE COIN COUNT IS SATISFIED,THE DOOR CLOSED AND THE START BUTTON PRESSED.
 4. CENTRIFUGAL SWITCHES-CONTACTS CHANGE POSITION WHEN MOTOR IS UP TO SPEED.
 5. REFER TO OWNERS MANUAL FOR DESCRIPTION OF OPERATION AND REQUIREMENTS FOR HEATING CIRCUIT.

SCHEMATIC

D_T_30KC_21CR

Wiring Diagram for Dryer 50hz 230V -21CR

