



DEXTER
LAUNDRY









Dexter Commercial Vended Stack Washer Dryer

Parts & Service Manual

Equipment Safety Warnings

Symbols and Terminology Used in this Equipment

 DANGER	Indicates an imminently hazardous situation, which if not avoided, will result in death or serious injury.
 WARNING	Indicates a potentially hazardous situation, which if not avoided could result in death or serious injury.
 CAUTION	Indicates a potentially hazardous situation which, if not avoided, may result in minor or moderate injury. It may also be used to alert against unsafe practices. Minor burns, pinch points that result in bruises and minor chemical irritation.
NOTICE	Indicates information or a company policy that relates directly or indirectly to the safety of personnel or protection of property.
	This is the user caution symbol. It indicates a condition where damage to the equipment resulting in injury to the operator could occur if operational procedures are not followed. TO REDUCE THE RISK OF DAMAGE OR INJURY, refer to accompanying documents; follow all steps or procedures as instructed.
 <small>©1998 HCL, Inc. 800-748-0241 No. 85198-002</small>	This is the electrical hazard symbol. It indicates that there are DANGEROUS HIGH VOLTAGES PRESENT inside the enclosure of this product. TO REDUCE THE RISK OF FIRE OR ELECTRIC SHOCK, do not attempt to open the enclosure or gain access to areas where you are not instructed to do so. REFER SERVICING TO QUALIFIED SERVICE PERSONEL ONLY
	Caution! There are sharp edges on various sheet metal parts internal to the enclosure. Use safety consciousness when placing or moving your hands while working in the interior of this equipment.
	Caution! To reduce the risk of damage to the Water Inlet Valve, do not supply inlet water with a temperature that exceeds 70° C. Caution! To reduce the risk of fire or explosion, do not operate this equipment in any hazardous classified (ATEX) environment.

Equipment Safety Warnings

Symbols and Terminology Used in this Equipment



Warning! Do not operate equipment if door glass is damaged in any way.



Warning! Keep clear of rotating parts.



Prohibited! Do not enter this equipment or space.



Prohibited! Do not step or stand on this equipment.



Prohibited! Do not operate without all guards and covers in place.









Prohibited! Do not operate without all guards and covers in place.



Prohibited! Do not wash clothing impregnated with flammable liquids (petrochemical).



Prohibited! Do not allow children to play in or around equipment.

	<p>Indicates an imminently hazardous situation, which if not avoided, <u>will result</u> in death or serious injury.</p>
	<p>Indicates a potentially hazardous situation, which if not avoided <u>could result</u> in death or serious injury.</p>
	<p>Indicates a potentially hazardous situation which, if not avoided, <u>may result</u> in minor or moderate injury. It may also be used to alert against unsafe practices. Minor burns, pinch points that result in bruises and minor chemical irritation.</p>
<p>NOTICE</p>	<p>Indicates information or a company policy that relates directly or indirectly to the safety of personnel or protection of property.</p>
	<p>This is the user caution symbol. It indicates a condition where damage to the equipment resulting in injury to the operator could occur if operational procedures are not followed. TO REDUCE THE RISK OF DAMAGE OR INJURY, refer to accompanying documents; follow all steps or procedures as instructed.</p>
	<p>This is the electrical hazard symbol. It indicates that there are DANGEROUS HIGH VOLTAGES PRESENT inside the enclosure of this product. TO REDUCE THE RISK OF FIRE OR ELECTRIC SHOCK, do not attempt to open the enclosure or gain access to areas where you are not instructed to do so. REFER SERVICING TO QUALIFIED SERVICE PERSONEL ONLY</p>
	<p>Caution! To reduce the risk of fire or explosion, do not operate this equipment in any hazardous classified (ATEX) environment.</p>



WARNING



- All washers must be installed in accordance to all applicable electrical, plumbing and all other local codes.

- These installation and operation instructions are for use by qualified personnel only. To avoid injury and electrical shock, do not perform any servicing other than that contained in the installation and operation instructions, unless qualified.



Do not install washers in an explosive atmosphere.



- Care must be stressed with all foundation work to ensure a stable unit installation, eliminating possibilities of excessive vibration.

- Foundation must be level within 13 mm to ensure proper washer operation.



Do not operate washer if door glass is damaged in any way.



Do not wash clothing impregnated with flammable liquids (petrochemical).



WARNING



Children should be supervised to ensure they do not operate or play in or around equipment.







Keep all panels in place to protect against electrical shock and injury and add rigidity to washer.

This appliance is not intended for use by persons (including children) with reduced physical, sensory or mental capabilities, or lack of experience and knowledge, unless they have been given supervision or instruction concerning use of the appliance by a person responsible for their safety.

A washer should not be allowed to operate if any of the following occur:

- **Excessive high water level.**
- **Machine is not connected to a properly earthed circuit.**
- **Door does not remain securely locked during the entire cycle.**
- **Vibration or shaking from an inadequate mounting or foundation**

	<p>Warning! Do not operate equipment if door glass is damaged in any way.</p>
	<p>Warning! Keep clear of rotating parts.</p>
	<p>Prohibited! Do not enter this equipment or space.</p>
	<p>Prohibited! Do not step or stand on this equipment.</p>
	<p>Prohibited! Do not operate without all guards and covers in place.</p>
	<p>Prohibited! Do not operate without all guards and covers in place.</p>
	<p>Prohibited! Do not wash clothing impregnated with flammable liquids (petrochemical).</p>
	<p>Prohibited! Do not allow children to play in or around equipment.</p>

	<p>Prohibited! Do not attempt to open, touch, or proceed before referring to the manual or unless qualified.</p>
	<p>Mandatory! Read all supporting documentation before operating or maintaining equipment.</p>
	<p>Mandatory! Disconnect power before servicing equipment.</p>
	<p>Mandatory! Lock out and tag out before servicing this equipment.</p>
	<p>Mandatory! Disconnect water supply before servicing equipment.</p>
	<p>Mandatory! Children should be supervised to ensure they do not operate equipment.</p>

Dexter Safety Guidelines



WARNING

These washers are equipped with devices and features relating to their safe operation. To avoid injury or electrical shock, do not perform and service, unless qualified to do so.

FOR SAFETY

1. Always shut off power and water supply and also discharge capacitors before servicing.
2. Do not overload the washer.
3. Do not attempt to open door if cylinder is in motion or contains water.
4. Do not mechanically force or override door lock in any way.
5. Do not bypass any safety devices of this washer.
6. Do not use volatile or flammable substances in or near this washer.
7. Keep all panels in place. They protect against shock and injury and add rigidity to the washer.

A machine should not be allowed to operated if any of the following occur:

- Excessively high water level.
- Machine is not connected to a properly grounded circuit.
- Loading door does not remain securely locked during the entire cycle.
- Vibration or shaking from an inadequate mounting or foundation.

To activate your warranty, be sure to return your red warranty form to the factory. Please have serial number and model ready when calling for assistance.

Table of Contents

Section 1:

Specifications, Mounting Dimensions

Specifications.....	12 & 15
Dimensions.....	16 & 17

Section 2:

Installation & Operating Instructions

Washer Installation	20
Electrical Connections & Fusing Requirements ..	21
Dryer Installation.....	22
Dryer Electric, Gas and Venting.....	23
Washer Operating Instructions.....	25
Emergency Stop Button	25
Dryer Operating Instructions.....	26

Section 3:

Washer and Dryer Programming Instructions

Washer Price Programming.....	28 & 29
Wash Cycle Programming.....	30 & 31
Coin Washer Cycle Parameter Ranges	31
Rapid Advance Mode.....	312
Dryer Programming.....	33 & 34

Section 4:

Dryer Service, Troubleshooting and Schematics

Dryer Service Procedures.....	36 - 42
Dryer Control Fault Codes.....	43
Dryer Troubleshooting Tips.....	43 - 45
Dryer Schematics 60hz.....	46 - 49

Section 5:

Dryer Parts Data.....51-78

Section 6:

Electric Heated Dryer

Dryer Schematics Electric Heated.....	80-87
Electric Dryer Parts.....	88-90

Section 7:

50hz Gas Dryers

50hz Dryer Parts.....	92
50hz Dryer Schematics.....	93-94

Section 8:

Washer Service and Troubleshooting

Mechanical Coin Drop Acceptor.....	96
Electronic Coin Drop Acceptor.....	97
Electronic Coin Drop Maintenance.....	98
Front Panel Removal	102
Back Panel Removal.....	102
Drain Valve Access.....	102
Drain Valve Cleaning	102
Masking Ring Removal	102
Detergent Dispenser	102
Vacuum Breaker/Air Gap	102
Water Valves	102
Door Lock Assembly Operation.....	103
Adjustment for Door Lock Assembly.....	104-105
Adjusting the Loading Door	106
Loading Door Removal	106
Loading Door Hinge Removal.....	106
Loading Door Disassembly	106
Loading Door Reassembly	107
Control Panel Name Plate Decal.....	107
Name Plate Removal	107
Re-Installation of Name Plate.....	107
Removal of the Washer Tub Assembly From the Washer Frame	107
Tub Back, Bearing and Cylinder Assembly	108
Basket Pulley, Bearing Housing, Water Seals & Tub Back.....	109
Bolt Torque Chart.....	110
Control Mounting Trough.....	111
Main Data Communication Cable.....	111
Circuit Breaker/Fuse.....	111
Main Control Printed Circuit Board.....	111
PCB Transformer Step Down.....	111
Controls Transformer.....	111
Main Relay Printed Circuit Board	111
LED Printed Circuit Board Temperature & Start Display Push Button.....	111
Add Bleach LED	112
Pressure Switch	112
Emergency Stop Button & Switch Assembly...	112
Power Connection Terminal Block	112

Delta Variable Frequency Drive.....	113
Delta VFD Motor Leads.....	113
Delta VFD Dynamic Braking Resistors	113
Delta VFD Cooling Fan	113
Washer Trouble Shooting and F - Codes...	114-121

Section 9:

Washer Electrical & Wiring Schematics

Start Circuit	124
Fill Circuit	124 & 125
Wash Circuit	125
Drain, Rinse 1 & 2 & Final Rinse Circuit	125
Extract Circuit.....	125
Thermoactuator and Shake Out Circuit.....	126
End of Cycle Circuit	126
Motor Winding Resistances.....	126
Washer Electrical & Wiring Schematics 60hz	128-131

Section 10:

Washer Parts Data

A-Series Accessories.....	134
Rear View Access Parts	136
Cabinet and Front Panel Group	138-141
Cylinder, Seals & Bearings Parts	142 & 143
Door Lock Parts	144
Loading Door Parts	156-149
Drain Valve Group Parts	150
Water Inlet Parts	151
Chasis and Drain Parts.....	152 & 153
Electrical Components	154-156
Labels.....	157
Coin Handling Group Parts	157 -158
Integrated Easy Card Control Panel Parts.....	159

Section 11:

50hz Washer	162
-------------------	-----

Section 12:

Maintenance Dryer.....	166
Maintenance Washer.....	167

Section 1:

Washer and Dryer

Specifications and
Mounting

Stacked Washer Dryer Models

Stacked Model Designation	Washer \ Dryer Model #	Electrical Spec: Circuit Breaker / Running Amps / Wire Size/ Option
SCAD60KCB-14US	DSTD30KCB-10US	120/60/1 - 2 wire + ground 15amp / 9.8 amp /#12 US=United States Quarter Acceptor
	WSAD30KCB-12US	208-240/60/1or3, Single 2 Wire + Ground, 3 Phase 3 Wire plus Ground US=United States Quarter Acceptor
SCAD60KCB-14USTS	DCTD30KCB-10USTS	120/60/1 - 2 wire + ground 15amp / 9.8 amp /#12 US=United States Quarter Acceptor TS= Stainless Tumbler
	WSAD30KCB-12US	208-240/60/1or3, Single 2 Wire + Ground, 3 Phase 3 Wire plus Ground US=United States Acceptor
SCAD60KCB-14CN	DCTD30KCB-10CN	120/60/1 - 2 wire + ground 15amp / 9.8 amp /#12 CN=no coin Mech
	WSAD30KCB-12CN	208-240/60/1or3, Single 2 Wire + Ground, 3 Phase 3 Wire plus Ground
SCAD60KCB-14CNTS	DCTD30KCB-10CNTS	120/60/1 - 2 wire + ground 15amp / 9.8 amp /#12 CN=no coin Mech TS=Stainless Tumbler
	WSAD30KCB-12CN	208-240/60/1or3, Single 2 Wire + Ground, 3 Phase 3 Wire plus Ground CN=no coin
SCAD60KCB-14EC	DSTD30KCB-10EC	120/60/1 - 2 wire + ground 15amp / 9.8 amp /#12 EC=EasyCard Ready
	WSAD30KCB-12EC	208-240/60/1or3, Single 2 Wire + Ground, 3 Phase 3 Wire plus Ground EC=EasyCard Ready
SCAD60KCB-14ECTS	DCTD30KCB-10ECTS	120/60/1 - 2 wire + ground 15amp / 9.8 amp /#12 EC=EasyCard Ready TS= Stainless Tumbler
	WSAD30KCB-12-EC	208-240/60/1or3, Single 2 Wire + Ground, 3 Phase 3 Wire plus Ground EC=EasyCard Ready
SCAD60KCB-14CP	DCTD30KCB-10CP	120/60/1 - 2 wire + ground 15amp / 9.8 amp /#12 CP=Program Acceptor, US, Canada,Japan,Tiwan
	WSAD30KCB-12CP	208-240/60/1or3, Single 2 Wire + Ground, 3 Phase 3 Wire plus Ground CP=Program Acceptor, US, Canada,Japan,Tiwan
SCAD60KCB-14CPTS	DCTD30KCB-10CPTS	120/60/1 - 2 wire + ground 15amp / 9.8 amp /#12 CP=Program Acceptor, US, Canada,Japan,Tiwan TS= Stainless Tumbler
	WSAD30KCB-12CP	208-240/60/1or3, Single 2 Wire + Ground, 3 Phase 3 Wire plus Ground CP=Program Acceptor, US, Canada,Japan,Tiwan

Stacked Washer Dryer Models

Stacked Model Designation	Washer \ Dryer Model #	Electrical Spec: Circuit Breaker / Running Amps / Wire Size/ Option
SCAD60KCB-14CP-STTS	DCTD30KCB-10CPTS	120/60/1 - 2 wire + ground 15amp / 9.8 amp / #12 CP=Program Acceptor, US, Canada,Japan,Tiwan TS=Stainless Tumbler
	WSAD30KCB-12CPST	208-240/60/1or3, Single 2 Wire + Ground, 3 Phase 3 Wire plus Ground CP=Program Acceptor, US, Canada,Japan,Tiwan ST=100G Extract Drive
SCAD60KCB-21CR	DCTD30KCB-21CR	230/50/1 - 2 wire + ground 15amp / 5.0amp / #12 CR=Program Acceptor, US, Canada,Japan,Tiwan ST=100G Extract Drive
	WSAD30KCB-21CR	230/50/1 - 2 wire + ground 15amp / 5.0amp / #12 CR=Program Acceptor, US, Canada,Japan,Tiwan ST=100G Extract Drive
SCAD60KCB-21CRTS	DCTD30KCB-21CRTS	230/50/1 - 2 wire + ground 15amp / 5.0amp / #12 CR-Program Acceptor Australia New Zealand TS= Stainless Tumbler
	WSAD30KCB-21CR	230/50/1 - 2 wire + ground 15amp / 5.0amp / #12 CR-Program Acceptor Australia New Zealand
SCAD60KCB-16US-FC	DCTD30KCB-16FC	208/60/3 - 4 wire + ground 24kW 90 amp / 85amp / #2
	WSAD30KCB-12US	208-240/60/1or3, Single 2 Wire + Ground, 3 Phase 3 Wire plus Ground US=United States Acceptor
SCAD60KCB-29FN-CR	DCTD30KCB-29FNCR	380/50/3 - 4 wire + ground 22kW 50 amp / 45 amp / # 6 CR=Program Acceptor, US, Canada,Japan,Tiwan
	WSAD30KCB-21CR	230/50/1 - 2 wire + ground 15amp / 5.0amp / #12 CR=Program Acceptor, US, Canada,Japan,Tiwan ST=100G Extract Drive
SCAD60KCB-60FA	DCTD30KCB-60FA	208/60/1 - 3 wire + ground 20kW 125 amp / 120 amp / #1/0
	WSAD30KCB-12US	208-240/60/1or3, Single 2 Wire + Ground, 3 Phase 3 Wire plus Ground US=United States Quarter Acceptor
SCAD60KCB-67FWST	DCTD30KCB--66FW	(415/50/3 - 4 wire + ground) - 15kW 32 amp / 30 amp / # 8
	WSAD30KCB-USST	208-240/60/1or3, Single 2 Wire + Ground, 3 Phase 3 Wire plus Ground US=United States Quarter Acceptor, ST=100G Extract Drive

Washer Specifications:

Dry Weight Capacity	30 lbs	(13.6 kg)
Cylinder Diameter	25"	(63.5 cm)
Cylinder Depth	14.13"	(35.9 cm)
Cylinder Volume	4 cu ft	(113.4 l)
Floor to Door Bottom	16"	(40.61 cm)
Door Opening	15.25"	(38.71 cm)

Speeds G-Force (RPM)

High Extract Speed	200 G	750 RPM
Intermed. Extract Speed	60 G	411 RPM
Washing Speed	.96	50 RPM
Motor Size	2 HP	1.5 kw

Electrical

Electrical Phase	Single or Three
Electrical Voltage (60 Hz)	208-240
Electrical Running (Amps)	6.2
Circuit Protection (Amps)	15 amp
Electrical Wire Size	12 gauge
Electrical Service (Single)	2 wire + ground
Electrical Service (Three)	3 wire + ground

Water

Water Inlet Size	3/4"	(19mm)
Flow Rate (per min)	9 gal	(34.1 L)
Pressure (min/max)	30-120 psi	(207-827 Kpa)
Drain Diameter (O.D.)	3"	(7.61 cm)
Floor to Center of Drain	4.5"	(11.23 cm)
Approximate Water Usage	28.0 gal	(106.0 l)

Installation Recommendations

Clearance Between Machines	1/2 (min)	(1.31 cm)
Clearance Behind Machines	24" (min)	(61.0 cm)
Concrete Thickness	6" (min)	(15.24 cm)
Net Weight	1039 lbs	(471.3 kg)
Shipping Weight	1090 lbs	(494.4 kg)

Approvals** UL/CSA

Cabinet Dimensions

Height - in (cm)	78.75"	(200.0cm)
Width - in (cm)	31.5"	(80.0cm)
Depth - in (cm)	48"	(115.2 cm)

Dryer Specifications:

Dry Weight Capacity	30 lbs	(13.6 kg)
Cylinder Diameter	30"	(76.21cm)
Cylinder Depth	27.5"	(69.95 cm)
Cylinder Volume	11.25 cu ft	(318 l)
Floor to Door Bottom	48"	(115.2 cm)
Door Opening	22.6875"	(57.63 cm)

Energy Data

Gas Models	60Hz - 80,000 BTU/hr	(26.4kW)/pocket
	50Hz- 80,000 BTU/hr	(26.4kW)/pocket

Electric Models See Below

Electrical Spec: Circuit Breaker / Running Amps / Wire Size

Gas

-21 (230/50/1 - 2 wire + ground) 15amp / 5.0amp / #12

-10 (120/60/1 - 2 wire + ground) 15amp / 9.8 amp /#12

Electric

-16FC (208/60/3 - 4 wire + ground) - 24kW 90 amp / 85amp / #2

-18FD (240/60/3 - 4 wire + ground) - 24kW 80 amp / 75amp / #3

-60FA (208/60/1 - 3 wire + ground)) - 20kW 125 amp /120 amp /#1/0

-61FB (240/60/1 - 3 wire + ground) - 20kW 110 amp /105 amp /#1/0

-29FN (380/50/3 - 4 wire + ground) - 22kW 50 amp / 45 amp /# 6

-27FL (220/50/1 - 2 wire + ground) - 20kW 110 amp / 105 amp /#1/0

-29FN (400/50/3 - 4 wire + ground) - 24kW 50 amp / 45 amp /# 6

-29FN (415/50/3 - 4 wire + ground) - 26kW 50 amp / 45 amp /# 6

-66FW (415/50/3 - 4 wire + ground) - 15kW 32 amp / 30 amp /# 8

Tumble Speed	47 RPM	
Air flow - cfm (M3/min)	60HZ-500	14.16 m3/min
Gas Supply Connection	0.5"	(12.7mm)
Natural Gas (water column)	5-8"	(12.7 - 20.3cm)
L.P. Gas Supply (water column)	11.5 - 14"	(29.2 - 35.5cm)
Operating (water column)	3.5" inches	
Make-Up Air	1.0 sq ft	(1394 sq cm)
Exhaust Size - in (cm)	6"	(20.3cm)
	Maximum Length with (2 elbows) 14ft.	

Shipping Dimensions

Height - in (cm)	83.25"	(211.5cm)
Width - in (cm)	33.0"	(83.2cm)
Depth - in (cm)	54.0"	(137.2cm)

Machine Dimensions:

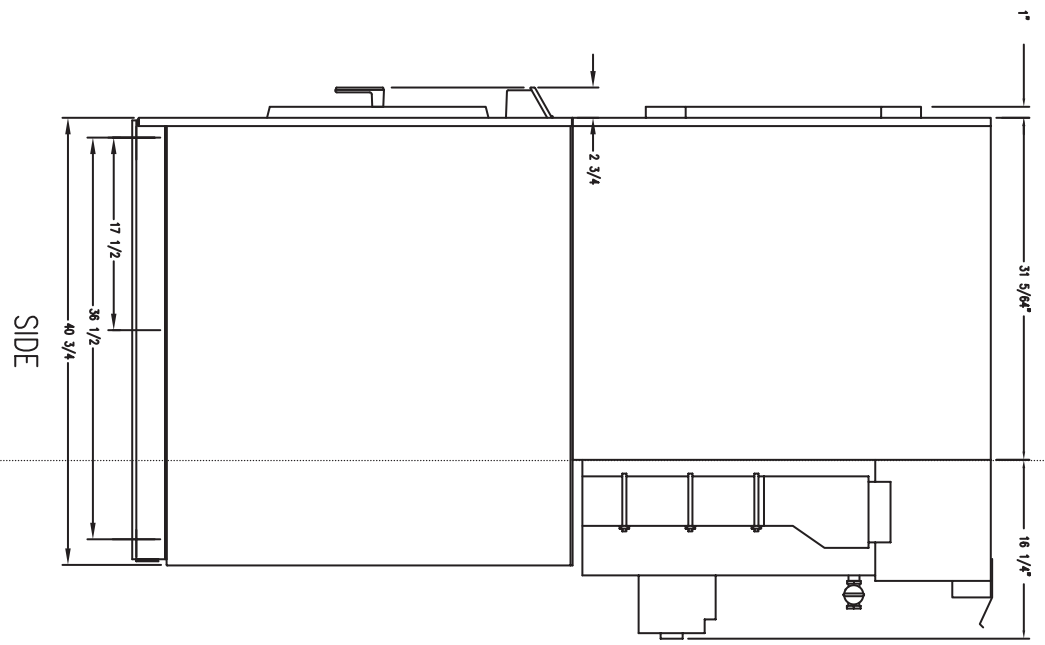
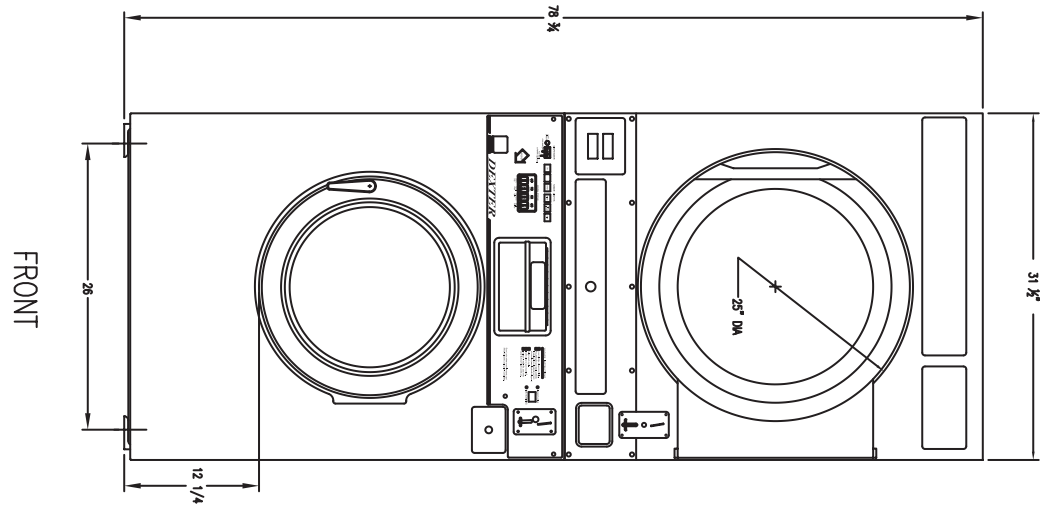

STACK WASHER/DRYER
MOUNTING DIMENSIONS

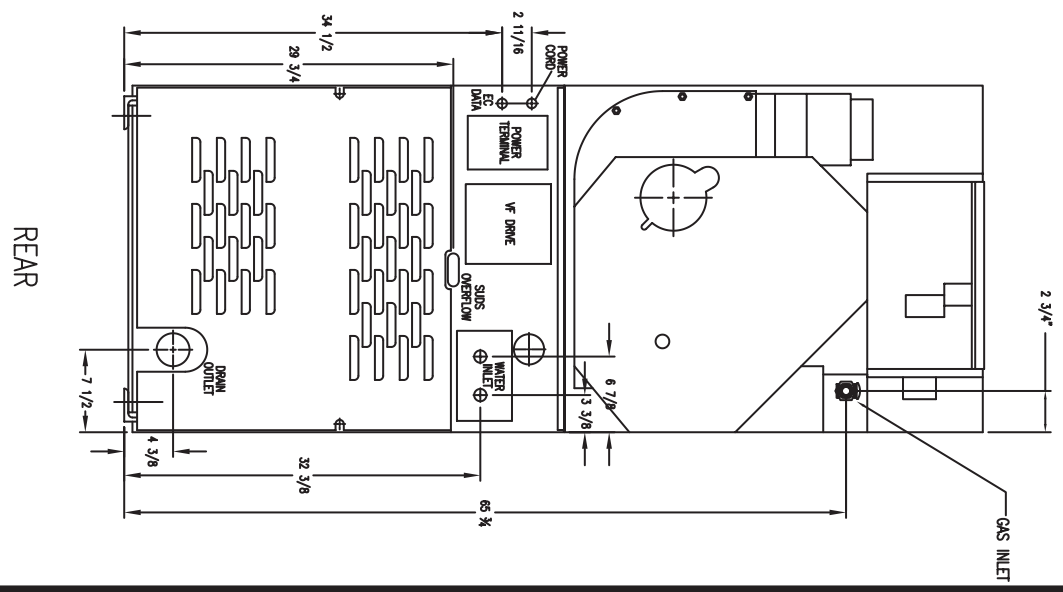

SWD Mounting Pad Dimensions

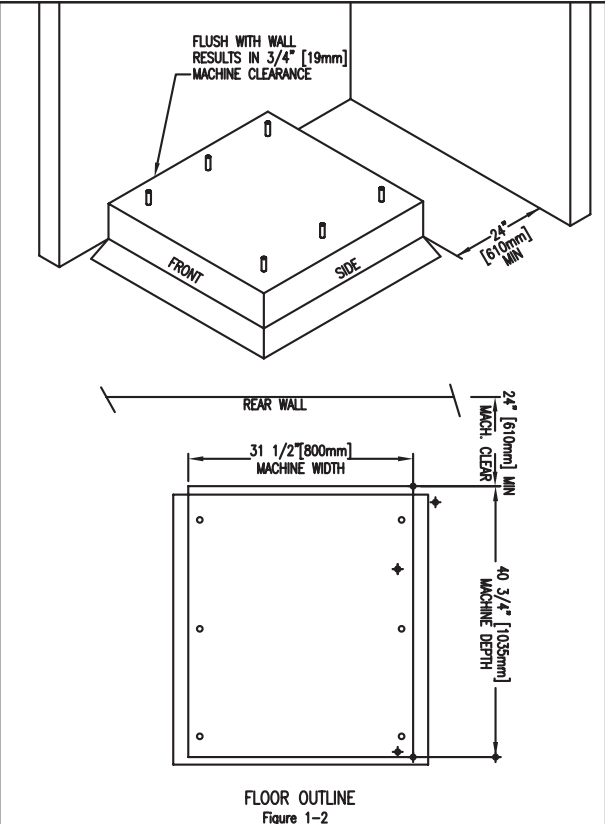
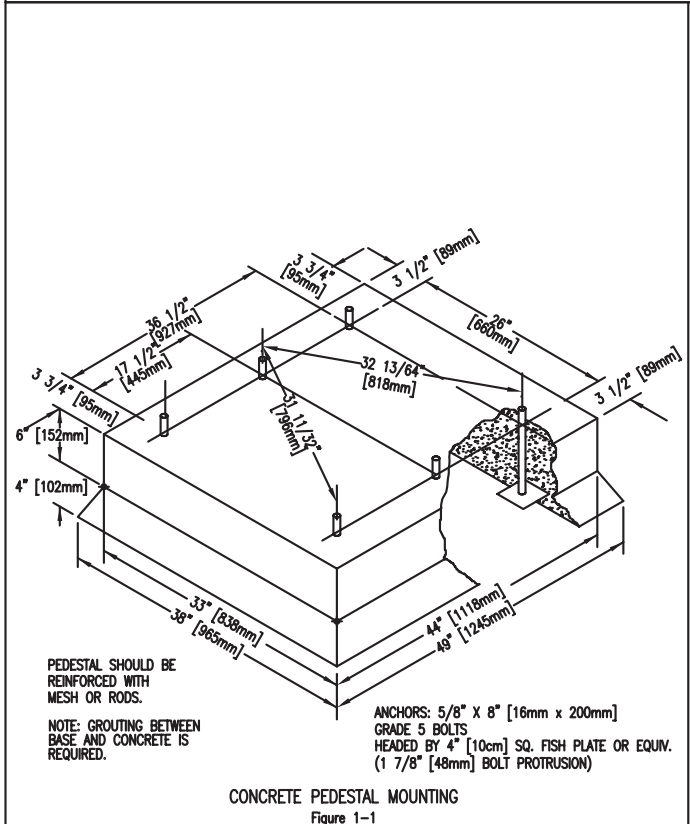
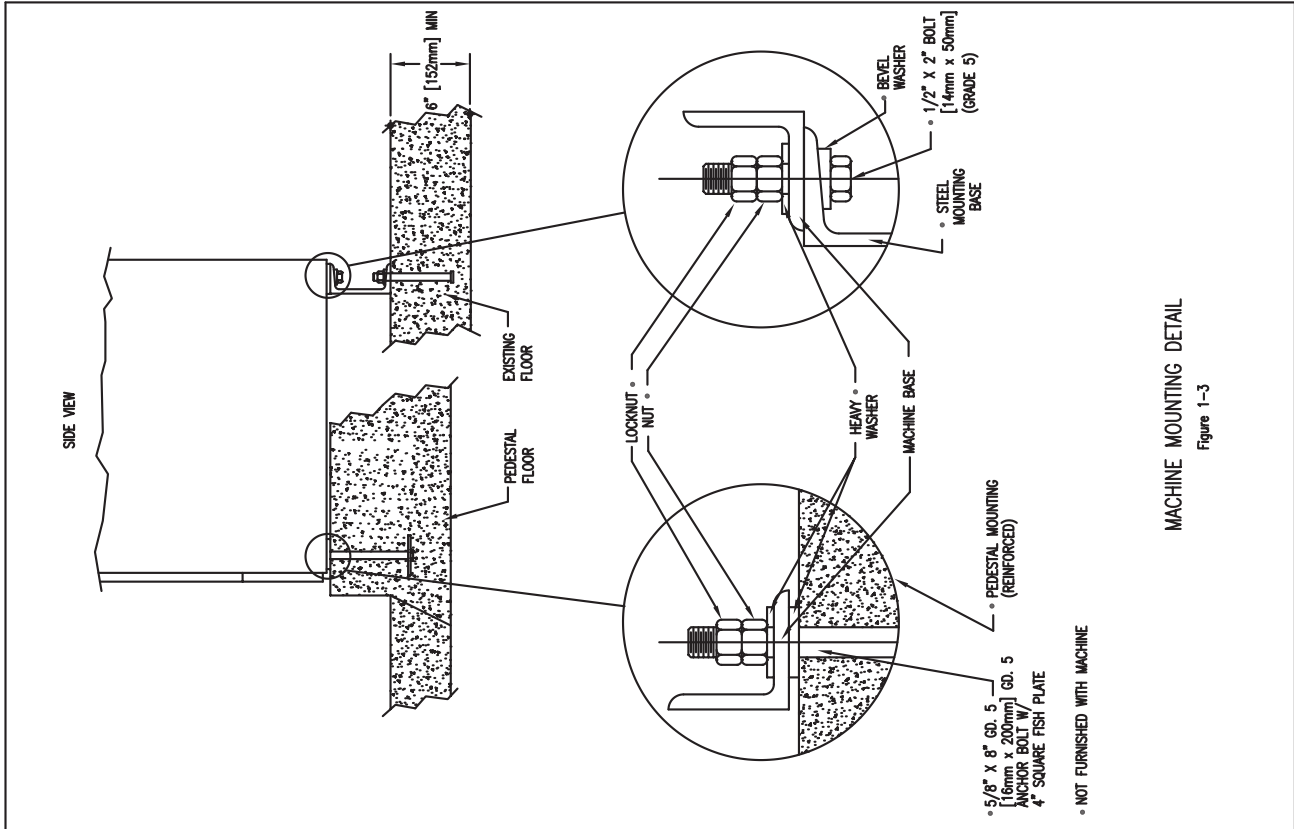

Section 2:

Washer and Dryer
Installation
& Operating
Instructions

Washer Installation

All washers must be installed in accordance with all local, state and national building, electrical, and plumbing codes in effect in the area.

Foundation Requirements

The washer must be securely bolted to a substantial concrete floor, or mounted upon a suitable base which is securely bolted and machine grouted to a substantial concrete floor. Care must be stressed with all foundation work to insure a stable unit, eliminating vibration. All installations must be made on sound concrete floors 6" or thicker. Anchor bolts must be of a quality grade and at least imbedded at minimum of 5" in length and minimum 5/8" diameter.

Mounting

A concrete pad or steel base which elevates the machine 4 to 6 inches above the floor level. To provide easy access to the loading door, it is recommended to allow a minimum of 18" of clearance behind the rear of the machine for service as is shown. SIX (6) bolts are required to mount the washer to the steel base or concrete pad. Grouting where base or machine makes contact with concrete is REQUIRED to achieve 100% surface contact and for warranty to be honored.

Note: Premanufactured bases are available from DEXTER factory (see sales dept.)

Mounting Bolts

The following pages illustrate the mounting dimensions for the machine and also show a typical concrete pad arrangement.

Note: Mounting bolts should be checked frequently to insure that they remain tight. The machine should be checked with a spinning load to be sure there is no unusual vibration or movement between the machine and the base or floor.

Proper Machine Grout Required Installation

Machine grout must be installed between base (if used) and concrete floor on all side rails and crossmembers. If using a base you must grout between base top and machine frame and all side rails and crossmembers.

Plumbing

Water supply hoses are furnished with each machine. The threaded connections on the hoses are standard garden hose type thread. Separate hot and cold water lines with shut off valves or faucets for inlet hose connections must be provided, maintaining 30 to 120 p.s.i. water flow pressure. Maximum water temperature is 180 degrees.

Drain

The drain outlet tube at the rear of the machine is 3" in outside diameter on models. Adequate fall for this gravity drain must be maintained for proper drainage.

Protective Film

The machine may have protective adhesive film on the front escutcheon area and the front and side stainless steel panels. The film may be peeled off before putting the machine into service.

Electrical

Dexter single/three-phase 208-240VAC 60 Hz washing machines are intended to be permanently installed appliances. No power cord is provided. The machine should be connected to an individual branch circuit not shared by lighting or other equipment. The connection should be sheathed in liquid tight flexible conduit, or equivalent, with conductors of the proper size and insulation. A qualified technician should make such connections in accordance with the wiring diagram.

Each unit should be connected to an individual branch circuit not shared by lighting or other equipment. Conductors of the proper size and insulation (suggested size below) should be used.

To Make Electrical Connections

Disconnect all power to the washer. Remove screw and lift out the cover located in the upper left corner of the machine (as viewed from the back).

- If power is 208-240-3PH-60Hz, connect L1, L2, L3 and ground. If there is a high leg it must be connected to L3. It is highly recommended to use a TVSS. (see Informative inside Washer)
- If power is 208-240-1PH-60Hz, connect L1, L2 and Ground.

NOTE: It is important that the grounding screw next to the power terminal block TB-1 be connected to a good external ground.

Controls Transformer

The controls transformer is located inside the control trough and steps a range of 208 to 240 volts down to 115 volts. There are two terminals on the controls transformer for the primary (incoming) power. Use the terminal marked "208V" for power supplies between 200 and 215 volts. Use the terminal marked "230V" for power supplies between 216 and 240 volts.

NOTE: transformer must be set at proper tap for proper operation.

Electrical Connections

Electrical power connections are made to the small terminal block located in the rear of the control trough. The terminal block is accessed by opening the top panel of the machine.

- 1 Phase or 3 Phase connections
- 208-240 volts, 60 Hz.
- 3 wire plus ground
- Suggested Minimum Wire Size -- 12 Ga.

Fusing Requirements:

Dual element time delay fuse or equivalent breaker of amperage specified below.

- 1 Phase or 3 Phase 15 amp
- WSAD-30

Rotation in extract as viewed through glass door at front of washer models WSAD-30 will be counter-clockwise.

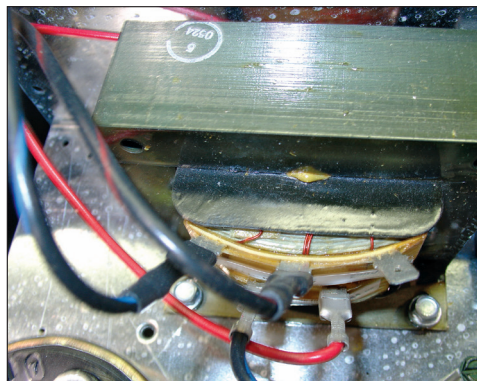
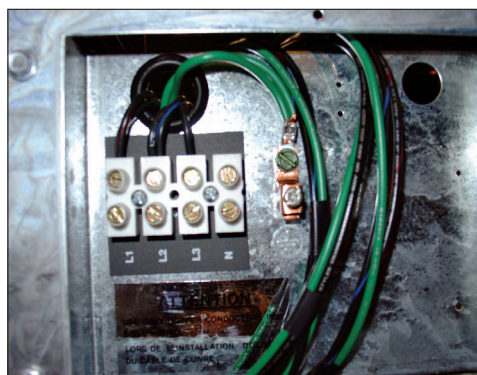

WARNING

Always disconnect electrical power to the machine before performing any adjustments or service.

Dryer Installation

All commercial dryer installations must conform with local applicable local codes or in the absence of local codes, with the National Fuel Gas Code ANSI Z223.1A-1988. Canadian installations must comply with current standard CAN/CGA-B149(.1 or .2) Installation Code for Gas Burning Appliances or Equipment, and local codes if applicable. The appliance, when installed, must be electrically grounded in accordance with the National Electric Code, ANSI/NFPA No. 70-1990, or when installed in Canada, with Standard CSA C22.1 Canadian Electrical Code Part 1.

Installation Clearances:

This unit may be installed at the following alcove clearances.

1. Left side- 0"
2. Right side- 0"
3. Back- 18" (Certified for 6" clearance: however 18" is required to clean, service, and maintain the dryer).
4. Front- 48" to allow use of dryer.
5. Top- Refer to figure labelled "Vertical Clearance Dimensions".
6. Floor- This unit may be installed upon a combustible floor.

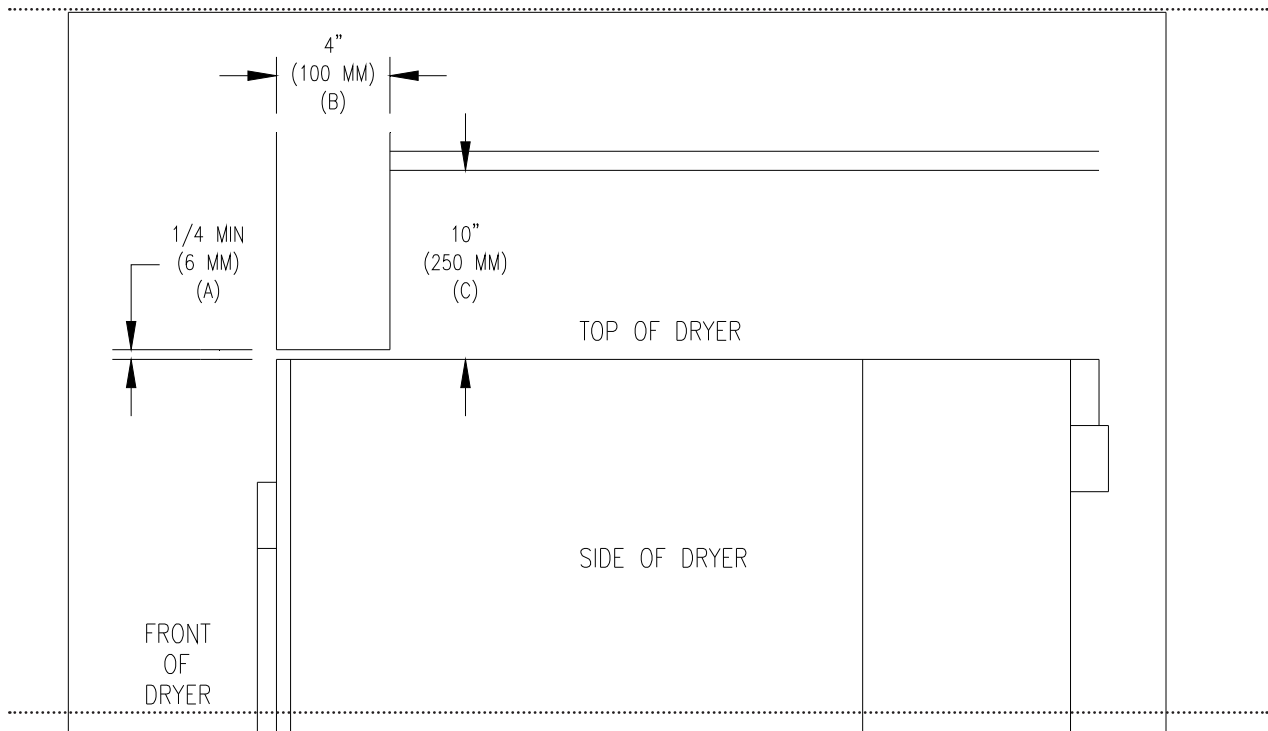

Makeup Air

Adequate makeup air must be supplied to replace air exhausted by dryers on all types of installations. Provide a minimum of 1 square foot of makeup air opening to the outside for each dryer. This is a net requirement of effective area. Screens, grills or louvers which will restrict the flow of air must be considered. Consult the supplier to determine the free area equivalent for the grill being used.

The source of makeup air should be located sufficiently away from the dryers to allow an even air flow to the air intakes of all dryers. Multiple openings should be provided.

NOTE: The following considerations must be observed for gas dryer installations where dry cleaners are installed. The sources of all makeup air and room ventilation air movement to all dryers must be located away from any dry cleaners. This is necessary so that solvent vapors will not be drawn into the dryer inlet ducts. Dry cleaner solvent vapors will decompose in contact with an open flame such as the gas flame present in clothes dryers. The decomposition products are highly corrosive and will cause damage to the dryer ducts and clothes loads.

Electrical Requirements

The electrical power requirements necessary to operate the unit satisfactorily are listed on the serial plate located on the back panel of each dryer. The electrical connection should be made to the terminal board on the rear of the unit using #10 AWG.

It is absolutely necessary that the dryer be grounded to a known ground. Individual circuit breakers for each dryer and washer are required. Use 15A circuit breakers for the 120V dryer. (See Dryer Specification Page for Electric Heated Models)

Gas Requirements

The complete gas requirements necessary to operate the dryer satisfactorily are listed on the serial plate located on the back panel of the dryer. The inlet gas connection to the unit is 1/2 inch pipe thread. However, the size of the piping to supply the dryer should be determined by reference to the Fuel Gas Code and consulting the local gas supplier.

A joint compound resistant to the action of liquefied petroleum gases should be employed in making pipe connections. A 1/8 inch NPT plugged tapping, accessible for test gage connection, must be installed immediately upstream of the gas supply connection to the dryer.

All pipe connections should be checked for leakage with soap solution or leak detector. Never check with an open flame.

CAUTION: The dryer and its individual shutoff valve must be disconnected from the gas supply piping system during any pressure testing of that system at test pressures in excess of 1/2 psig. The dryer must be isolated from the gas supply piping system by closing its individual manual shutoff valve during any pressure testing of the gas supply piping system at test pressures equal to or less than 1/2 psig.

Burner Set-Up

All gas burner manifolds should be checked for proper gas pressure while burning. Dryer burners should be set at 3.5 W.C. for Natural Gas while burner operating.

Exhaust Installation

Exhausting of the dryer should always be planned and constructed so that minimum air restrictions occur. (Refer to Figure on dryer exhausting). Maximum static back pressure allowed at rear exit of dryer is .3 SBP.

Any restriction due to pipe size or type of installation can cause slow drying time, excessive heat, and lint build up in system and the room.

From an operational standpoint, incorrect or inadequate exhausting can cause cycling of the high limit thermostat which shuts off the main burners and results in inefficient drying.

Individual exhausting of the dryer is recommended. All heat, moisture, and lint should be exhausted outside by attaching a pipe of the proper diameter to the dryer adapter collars and extending it out through an outside wall. This pipe must be very smooth on the inside, as rough surfaces tend to collect lint which will eventually clog the ducts and prevent the dryer from exhausting properly. All elbows must be smooth on the inside. All joints must be made so the exhaust end of one pipe is inside the next one

downstream. The addition of an exhaust pipe tends to reduce the amount of air the blower can exhaust. This does not affect the dryer operation if held within practical limits. For the most efficient operation, it is recommended that no more than 14 feet of straight 6" diameter pipe with two right angle elbows be used for each cylinder. When more than two elbows are used, two feet of straight pipe should be removed for each additional elbow. No more than two right angle elbows should be used to exhaust each cylinder.

If the exhaust pipe passes through a wall, a metal sleeve of slightly larger diameter should be set in the wall and the exhaust pipe passed through this sleeve. This practice is required by some local codes and is recommended in all cases to protect the wall. This type of installation should have a means provided to prevent rain and high winds from entering the exhaust when the dryer is not in use. A hood with a hinged damper can be used for this purpose. Another method would be to point the outlet end of the pipe downward to prevent entrance of wind and rain. In either case, the outlet should be kept clear by at least 24" of any objects which would cause air restrictions.

Never install a protective screen over the exhaust outlet.

When exhausting a dryer straight up through a roof, the overall length of the duct has the same limits as exhausting through a wall. A rain cap must be placed on top of the exhaust and must be of such a type as to be free from clogging. The type using a cone shaped "roof" over the pipe is suitable for this application. Exhausting the dryer into a chimney or under a building is not permitted. In either case there is a danger of lint buildup which can be highly combustible.

Installation of several dryers where a main discharge duct is necessary, will need the following considerations for installation. Whether using the 8" exhaust kit or individual 6" ducts, entrance into the main discharge duct should be at a 45 degree angle in the direction of discharge air flow.

NOTE: A small diameter duct will restrict air flow, a large diameter duct will reduce air velocity, both contributing to lint build up, An inspection door should be provided for periodic clean-out of the main duct.

NOTE: STATIC BACK PRESSURE should be a maximum of 0.3 in. w.c (7.6 mm w.c) at the rear exhaust outlet of the dryer. If multiple dryers are connected to the common duct, ensure the back draft damper is installed properly.

NOTE: The following illustration shows the various round main duct diameters to use with the individual dryer ducts. The main duct can be rectangular or round, provided adequate air flow is maintained. For each individual cylinder the total exhausting (main discharge duct plus duct outlet from the dryer) should not exceed the equivalent of 14 feet and two elbows. The diameter of the main discharge duct at the last dryer must be maintained to exhaust end.

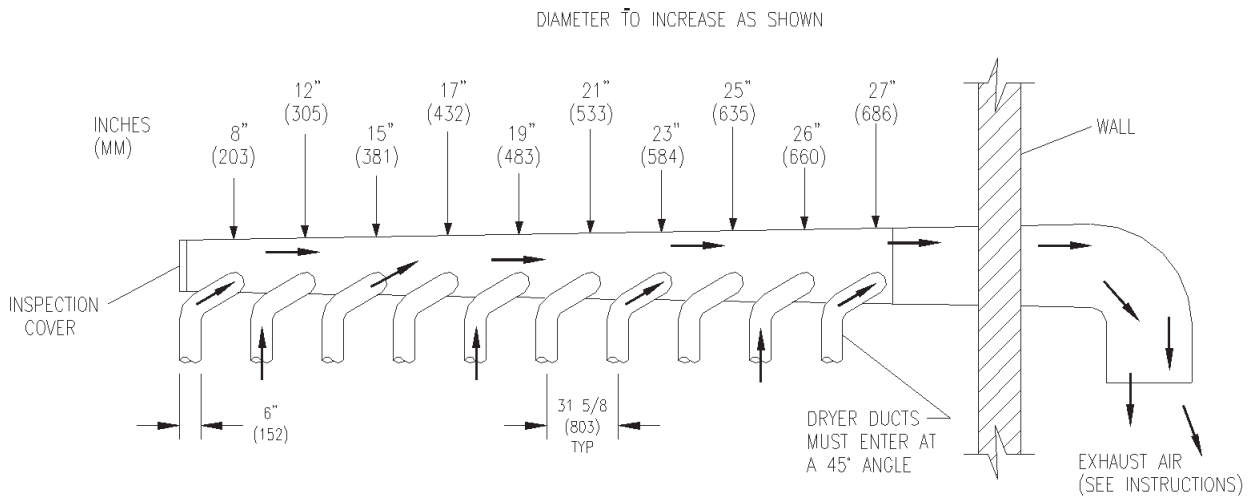

Washer Operating Instructions

Washer Emergency Stop / Safety Door Lock

This machine is equipped with a Safety Door Lock that locks the door closed from when the cycle is started until the cycle is complete. The door lock prevents opening the door for up to 3 minutes if the power is interrupted during the cycle.

The Emergency Stop button pauses the washer and allows the door to be opened during the cycle after the Safety Door Lock releases. When the Emergency Stop button is pressed an alarm will sound and the display will begin counting down from "3". If the button is released before 3 seconds elapse, the alarm will stop and the cycle will continue normally. If the Emergency Stop is held down for 3 seconds, the display will count down to "0" and the washer will begin stopping movement and water flow and begin draining water from inside the washer. Though the machine may stop wash movement quickly, it may take up to 3 minutes for the door to unlock. During that time the alarm will continue to sound. When the alarm stops, the door may be opened. The washer may be restarted by closing and latching the door, and pressing the Start button. If the washer was stopped during final extract, the cycle will be ended. If the washer is stopped for more than 1 hour, the cycle will be terminated. If the emergency stop is triggered a second time during the cycle, the cycle will be terminated.

Microprocessor

Prior to operation, the micro computer should be set to display the amount of vend price being offered and the cycle to be given to the user. NOTE: Should a power loss occur during cycle and when power returns, P U S H will be displayed in window and customer must push the START button to continue the cycle.

Starting the Washer

- A. Load the clothes loosely in the cylinder and latch the door securely. Be sure clothing does not get caught between the door gasket and tub front when closing the door.
- B. Pour low-sudsing powdered detergent in the amount shown below into the detergent dispenser on top of the machine. Rinse conditioners may also be added to the dispenser. The correct location is shown on the dispenser lid.

NOTE: To close the door the handle must be in the horizontal position and then moved to the vertical position . After moving the door to the closed position, the handle must be turned down to the vertical position to latch the door for machine operation.

- C. Using the TEMPERATURE SELECT buttons on the front, select the desired temperature. If temperature pricing is being used you will display price changes as you push the desired temperature selection.
This selection must be made before inserting coins to satisfy temperature price selected.If coins or value are added after extended plus cycle vend price is met it will be lost without credit. If water temperature pricing feature is active and vend price met and machine started the customer may change temperature selections of equal to or lower priced temperature selections already inserted into machine.
- D. Insert coins, tokens or activate card reader to meet displayed vending price. The washer will start, the display will read PUSH and the green "on" led will glow. The green start pushbutton must be pushed to start cycle time countdown and machine starting to run. "Door" will display if loading

- door is not closed and handle locked.
- E. If utilizing ADD PLUS CYCLE \$.000 option The front display will scroll, ADD PLUS CYCLE .25(example), amount to be added. User will have 1 minute to insert proper amount to activate this option.
 - F. At the correct time in the wash bath cycle the green "ADD BLEACH" light will come on indicating the time and showing a diagram of the location for adding bleach if desired. The timing is 2 1/2 minutes after start of wash bath the light will come on and stay on for 2 1/2 minutes or end of wash bath .

Detergent Measurements



Triple Load SWD Washer

End of Cycle

When the cycle is completed, the end of cycle buzzer will sound and the "on" light will go off. The loading door can now be opened by turning the door handle to the indicated position and pulling. Leave the clothes door open when the machine is not in use. Also, at the end of cycle the display will reset to the original amount required to start.

Dryer Operating Instructions

Description of Electronic Control

The single electronic control unit controls the coin count, dry time, temperature and information display. The digital display shows vend price when waiting for coins to be inserted and time purchased after coins have been deposited. When the tumbler is in use, the display shows the number of minutes remaining to be used. The three temperature selection buttons have indicator lights to indicate which temperature selection has been made. At the end of the cycle, the digital display flashes until the operator opens the door to remove the load. Temperature readout is available by pressing the temperature selection button that is in use along with the start button.

Electronic Control Features Available

1. **Anti-Wrinkle**
After a dryer has completed its dry time, the dryer will tumble intermittently without heat, until the door is opened. This is to reduce wrinkling of the clothes. This feature may be selected by removing a jumper from the electronic control.
2. **Last Temperature Used**
After a dryer has completed its dry time, the temperature that was being used will be selected for the next use, unless the new user selects a different one. This feature may be selected by removing a jumper from the electronic control.
3. **Battery Back-up**
All programmed and dry time remaining data are protected from power interruption by battery back-up.

Operating Instructions

1. Load clothes into the tumbler and close the door.
2. Deposit the vend price that is shown in the display.
3. Select the desired temperature. Temperature selection may be changed at any time during the cycle.
4. Push the start button to start the dryer.
5. Additional time may be purchased as long there is time remaining in the display, even if the amount added is less than the original vend price.

IMPORTANT: Opening the loading door will stop the dryer. However, the computer will continue to count down the time.

6. There is an owner programmable cool-down period at the end of the cycle. During the cool-down period, the dryer tumbles and the blower operates with the heat off to cool down the clothes.

TRANSIENT VOLTAGE SURGE SUPPRESSORS

Like most electrical equipment your new machine can be damaged or have its life shortened by voltage surges due to lightning strikes which are not covered by factory warranty. Local power distribution problems also can be detrimental to the life of electrical components. We recommend the installation of transient voltage surge suppressors for your new equipment. These devices may be placed at the power supply panel for the complete installation and don't require an individual device for each machine.

These surge protectors help to protect equipment from large spikes and also from small ongoing spikes in the power that occur on a day to day basis. These smaller surges can shorten overall life of electrical components of all types and cause their failure at a later date. Although they can't protect against all events, these protective devices have a good reputation for significantly lengthening the useful life of electronic components.

Electronic Components are helped to have a longer useful life when they are supplied with the clean stable electrical power they like.

We are including the following names and links to a few suppliers of these devices for those who don't currently have a source.

MANUFACTURER	LINK
MCG Surge Protection	mcgsurge.com
Eaton Corporation	eaton.com/us/en-us
Schneider Electric	se.com/us/en
Asco Power Technologies	ascopower.com/us/en
Emerson Electric Co.	emerson.com/en-us

Section 3:

Washer and Dryer Programming Instructions

Programming Instructions

Programming can be accomplished manually using the machine controls or by connecting to the machine control using a PDA (personal digital assistant). For instructions on using a PDA with this washer control, please contact your local Dexter distributor. Please read below for manual programming instructions.

The washer has two levels of programming. The Washer Cycle Programming allows the owner complete access to the wash cycle parameters: add/remove a bath, bath times, spin times, water temperatures, etc. The Coin/Price Programming allows the owner to set the price for the washer features and the values of the coins. To enter the programming modes, the top of the washer must be unlocked and slid toward the back of the washer a few inches.

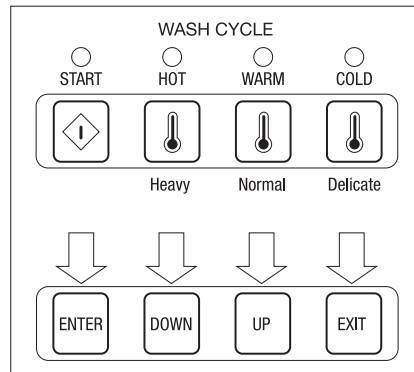

Coin Price Programming

While the washer is in the Idle mode, push the Programming pushbutton on the controller. The Idle mode is when the washer is not running a cycle and the price of the bath is displayed. The Programming pushbutton is a very small button located on the upper center of the controller directly behind the display. There are seven stages in the Coin/Price Programming mode.

To step through to the desired stage, repeatedly push the Start button until the desired stage is blinking on the display. To exit the Coin/Price programming mode, push and hold the Cold temperature button for 5 seconds.

- #1 Right Coin:** The display will blink first an "r" indicating right coin and then a coin value (\$1.00: default). The display will blink back and forth between the "r" and the value. To change the value, use the Hot temperature button to decrease and the Warm temperature button to increase. The value will change in 1¢ steps. The range of values is from \$00.00 to \$99.99. When the desired right coin value is displayed, push Start button once to store the new value and a second time to move to the next Coin/Price programming step. To exit the Coin/Price programming mode, push the Cold temperature button for 5 seconds.
- #2 Left Coin:** The display will blink first a "L" indicating left coin and then a coin value (\$0.25– default). The display will blink back and forth between the "L" and the value. To change the value, use the Hot temperature button to decrease and the Warm temperature button to increase. The value will change in 1¢ steps. The range of values is from \$00.00 to \$99.99. When the desired left coin value is displayed, push the Start button once to store the new value and a second time to move to the next Coin/Price programming step. To exit the Coin/Price programming mode, push the Cold temperature button for 5 seconds.
- #3 Wash Price:** The display will blink first a "P" indicating wash price and then present wash price. The display will blink back and forth between the "P" and the price. To change the value, use the Hot temperature button to decrease and the Warm temperature button to increase. The value will change in 1¢ steps. The range of values is from \$00.00 to \$99.99. When the desired price is displayed, push the Start button once to store the new value and a second time to move to the next Coin/Price programming step. To exit the Coin/Price programming mode, push the Cold temperature button for 5 seconds. FREE START can be set by dropping the wash price to \$0.00.

Water Temperature Pricing

The washer can be set for different levels of pricing for Cold, Warm and Hot water. The Cold water setting is considered as the base price, which is the normal washer cycle price.

#4 Warm Water Price: The next step in the pricing program is to set the additional price for Warm water usage. The display will blink first "CH P" indicating cold/hot water mix price and then "00.00". To change the value, use the Hot temperature button to decrease and the Warm temperature button to increase. The value will change in 1¢ steps. The range of values is from \$00.00 to \$99.99.

NOTE: To not use this feature, set the price to "00.00".

When the desired price is displayed, push the Start button once to store the new value and a second time to move to the next Coin/Price programming step. To exit the Coin/Price programming mode, push the Cold temperature button for 5 seconds.

#5 Hot Water Price: The next step in the pricing program is to set the additional price for Hot water usage. The display will blink first "H P" indicating hot water price and then "00.00". To change the value, use the Hot temperature button to decrease and the Warm temperature button to increase. The value will change in 1¢ steps. The range of values is from \$00.00 to \$99.99.

NOTE: To not use this feature, set the price to "00.00".

When the desired price is displayed, push the Start button once to store the new value and a second time to move to the next Coin/Price programming step. To exit the Coin/Price programming mode, push the Cold temperature button for 5 seconds. The Coin/Price programming mode will automatically exit and return to the Idle mode if no buttons are pushed for one minute.

#6 Plus Cycle Price: The next step in the programming sequence is the Plus Cycle feature. The Plus Cycle adds three (3) minutes of wash time to the wash bath only. The controller can be programmed to charge a fee for this or the feature can be turned off. The default setting is off (\$0.00).

The display will blink first a "PC P" indicating Plus Cycle price and then price (back and forth). To change the value, use the Hot temperature button to decrease and the Warm temperature button to increase. The value will change in 1¢ steps. The range of values is from \$00.01 to \$99.99. When the desired price is displayed, push the Start button once to store the new value and a second time to move to the next Coin/Price programming step. To exit the Coin/Price programming mode, push the Cold temperature button for 5 seconds.

#7 Decimal Point: The next step in the programming sequence is the Decimal Point. The display will blink "dP" and Default value is ON. The value "on" for enable or "off" for disable. Once a pushbutton is pressed, the display will stop blinking and show the decimal point value. The decimal point value will display and change with the Hot and Warm buttons. When desired value is reached press Start button.

Wash Cycle Programming

To change a feature of the wash cycle, push and hold the Hot temperature button and then push the programming pushbutton on the controller. The Washer must be in the Idle mode to enter the Wash Cycle Programming mode. When entering the cycle programming mode the Bleach LED will start to blink and continue to blink as long as you are in the Cycle Programming mode. The display will show "C 0". This is the default cycle number.

NOTE: The washer can be returned to the factory default settings by holding the right Warm button and then pressing the left Warm button. The display must show "C 0" to do this. When the cycle default values are loaded, the washer will automatically exit the programming mode.

NOTE: The Wash Cycle programming mode will automatically exit and return to the Idle mode if no buttons are pushed for one minute.

To change the washer cycle, push the Hot temperature button once. The display will change to "C 1", indicating cycle one is selected. The temperature buttons are used to make changes to the program. In the program mode, these buttons will do as displayed in drawing below.

When the display shows "C 1", push Enter. The display will show "b " and the PreWash mode light will blink. Use the Up/Down buttons to move to the bath that will be changed. As Up/Down buttons are pushed, the next bath mode light turns on.

When the Up button is pushed, the lit bath mode changes from Prewash to Wash. With each additional push of the Up button, the lit bath mode changes from left to right: Prewash, Wash, Rinse and Final Rinse. As there are two possible Rinse bathes, for Rinse 1 the Rinse LED and the display changes to "b" in the left digit and "r1" in the two right hand digits. For Rinse2, the display changes to "b" in the left digit and "r2" in the two right hand digits. Note that the Spin light is not used. When the Down button is pushed, the lit bath mode changes from Prewash to Final Rinse, etc.. There is a wrap around feature on the display in both directions. When the desired bath mode light is on, push Start.

Bath Cycle Time

The selected bath LED begins to blink. The display shows the letters "ct" in the left two digits and the bath cycle time in the right two digits. Again the up/down buttons change this value. The range is shown below. If zero time is entered, then the bath will be skipped and the program will return to the bath selection. When the desired cycle time is selected, push Start.

Bath Water Temperature

The display shows the letter "t" in the left digit and the letters "CC" appear in the right two digits. This is the bath water temperature. The selection choices are shown below but for the coin washer the value is defaulted to CC. As it is not selectable with a coin washer, the owner pushes Start to continue.

Bath Water Level

The display shows the letter "L" in the left digit and the letters "LO" appear in the right two digits. This is the bath water level. The selection choices are shown below but for the coin washer the value is defaulted to LO. As it is not selectable with a coin washer, the owner pushes Start to continue.

Bath Delay Fill

The display shows the letters "dF" in the left two digits and the letter "t" appears in the right digit. This is the bath delay fill. The selections are "t" for decrementing bath time during the fill or "d" for delay the bath time until water level is reached. When the desired selection is made, push Start.

Bath Spin

The display shows the letter "S" in the left digit and the bath spin time in the right two digits. Again the up/down buttons change this value. The range is shown below. When the desired spin time is selected, push Start. The display shows the letters "IS" in the left two digits and the injection selection appears in the right digit. For the coin washer the default value is "0" and cannot be changed. Push COLD.

The display will show "b" and the bath LED lights will stop blinking. Again use the up/down buttons change the bath selection. To exit the programming mode, push and hold COLD until price is displayed. The cycle will be stored when exiting the programming mode.

Coin Washer Cycle Parameter Ranges

The range of each cycle parameter is shown below:

Bath Cycle Time "ct"
0 to 15 minutes for Prewash, Rinse1 and Rinse 3 to 15 minutes for Wash and Final Rinse. For the baths that can, if the time is set to zero, then that bath will be eliminated from the cycle.
Bath Water Temperature "t"
HH – hot, CH – warm, CC – cold, EE – no water. The owner can set the bath default. For the wash bath, the default is over ridden for that cycle by the customer when the temperature is selected.
Bath Water Level "L"
LO – low The owner can change the displayed value, but for a coinwasher only LO will be put into the cycle.
Bath Delay Fill "dF"
The selections are "d" for delay the bath time until water level is reached or "t" for decrement bath time during the fill.
Bath Spin Time "S"
0 to 10 minutes for Prewash, Wash, Rinse1 and Rinse2 1 to 10 minutes for Final Spin.
Bath "IS"
The owner can change the displayed value, but for a coin washer only 0 will be put into the cycle.

Coin Washer Default Cycle (Preset at Factory)

The following table shows the complete details for the coin washer default cycle.

Bath	Bath Cycle Time (min.)	Water Temp.	Water Level	Delay Fill	Spin Time (min.)	IS *
Prewash	0					
Wash	9	CH	LO	t	0	
Rinse 1	4	CC	LO	t	0	0
Rinse 2	0					
Final Rinse	5	CC	LO	t	4	0

*NOTE: These default values are preset and cannot be changed.

Rapid Advance Mode

To enter the Rapid Advance mode, push and hold the Cold water temperature button and then push the programming button on the controller. There will be no observed change to the washer or the display. The Rapid Advance mode can be entered from either the Idle mode or during the cycle. To rapid advance to the next step in the wash cycle, push both Start and Warm temperature buttons at the same time. The display will show an "Ad" (advance) in the display. The washer will advance to the next bath segment. The water will drain before the advance will occur.

To exit the Rapid Advance mode, push and hold the Cold temperature button for 5 seconds or more.

NOTES:

Step 1: When the Rapid Advance mode is used, the cycle time will no longer be correct.

Step 2: By skipping steps with rapid advance, the door may not open immediately at the end of the cycle.

Main Control Printed Circuit Board

This control has a battery that allows memory retention in case of main power loss. The battery may need replacing if time of day options are not functioning properly.

Remove power from machine and lockout safely.

Remove battery from socket on circuit board and reinstall new battery (#8612-001-001).

CAUTION: Do not soft reset this machine when installing new battery. This will reset internal clock and not allow re-startup of internal clock, possibly causing programming trouble.

Coin Dryer Control / Operation

Description of Controls

Credit for coins deposited, dryer time and temperature are controlled by an electronic control.

The large digital display shows vend price of an idle dryer, time purchased after coins are deposited, temperature and program information.

The three red indicator lights show the drying temperature selected. This selection may be made anytime.

The drying temperature will be displayed when the start switch and the switch for selected temperature are pressed at the same time.

All programmed data is protected from power interruption of any length, and the customer's cycle is protected for up to 3 seconds. This is done without batteries.

The 3 temperature buttons and the start button become programming switches when the controller is in the program mode as described below.

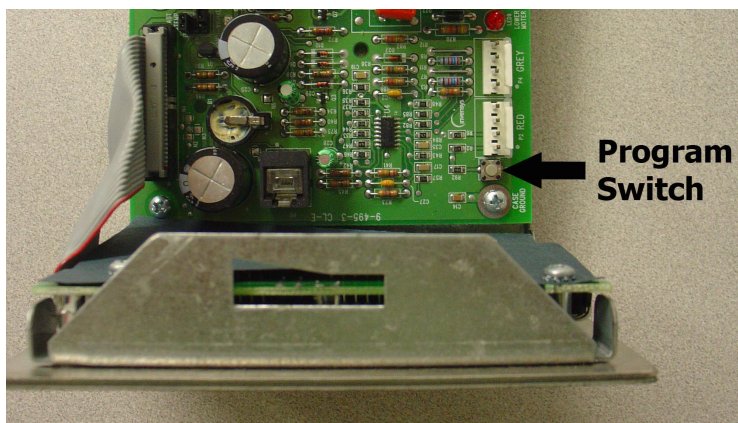

Coin Dryer Programming

To change programmed values or zero registers:

1. Open the loading door
2. Unlock the control tray, carefully slide the control tray assembly forward about three inches. Press the program switch. (See Figure 4 A Top View of Controller@) Reinstall and lock the controller. The controller is now in the program mode at the A00" step, displaying the hours run by the lower drum. Refer to the table defining the steps.) This value displayed can be reset to A0" or observed and left as is: Pressing the start switch will advance the controller through the fifteen remaining steps allowing observation or alteration. Note that on any program change or reset it is necessary to advance to the next step by pressing the lower hot switch to enter the revision. Otherwise the value will remain as it was before the alteration.

Programming:

All operating parameters (vend price, temperatures, cool-down times, etc.) are adjustable. There are also several displays of information available from the controller (money audits, hours run, dryer temperature.)

The dryer is shipped ready for operation with the following pre-programmed data:

Temperature, HOT:	175 F/ 78 C
Temperature, MEDIUM:	150 F/ 63 C
Temperature, Warm:	125 F/ 48 C
Vend Price:	25 cents
Time for Left Coin Slot:	3:20 (does not apply to single coin models)
Time for Right Coin Slot:	10:00 (10 minutes for 25 cents)
Time for Free Vend:	10:00
Cool-down Time HOT:	2:00
Cool-down Time MEDIUM:	2:00
Cool-down Time, WARM:	2:00
Temperature Scale	F degrees

All of the above data can easily be changed by the owner. The changes are made by the 4 keys or buttons on the front of the control panel.

Cycle Lights	Display	Programming Step	Options/ Range	Factory Settings
		Hour Meter	May be reset / 0 to 9999hr.	0
● _H ● _M ● _W	- -	Left Coin Audit	May be reset / 0 to 9999 coins	0
● _H ● _M ● _W	- -	Right Coin Audit	May be reset / 0 to 9999 coins	0
● _H	-	Temperature Hot	150 to 190 Degrees F (5 degree increments)	175
● _M	-	Temperature, Perm Press	120 to 170 Degrees F (5 degree increments)	150
● _W	-	Temperature, Warm	110 to 150 Degrees F (5 degree increments)	125
	- -	Left Coin Value	0 to \$99.99 Cents (1 Cent Increments)	\$0.10
	- -	Right Coin Value	0 to \$99.99 Cents (1 Cent Increments)	\$0.25
	-	Vend Price	0 to \$ 99.99 (1 Cent Increments)	\$0.25
	- - -	Time For Left Coin	0 to 99:55 (5 sec. increments)	10:00
	- - -	Time For Right Coin	0 to 99:55 (5 sec. increments)	10:00
	-	Time Free Vend	0 to 99:55 (5 sec. increments)	10:00
● _H	- -	Cool-Down Time Hot	0 to 10:00 (5 sec. increments)	2:00
● _M	- -	Cool-Down Time Med	0 to 10:00 (5 sec. increments)	2:00
● _W	- -	Cool-Down Time Warm	0 to 10:00 (5 sec. increments)	2:00

Section 4:

Dryer Service,
Trouble Shooting
and Schematics

Service Procedures

Clothes Door Removal

1. The clothes door may be removed from the hinge bracket by unscrewing and removing the allen-head pivot screw located at the door upper hinge point.
2. Next lean the door out of the top of the hinge bracket and lift the door from the bottom hinge pin.

NOTE: the spacer between the bottom of the door and the hinge.

Clothes Door Latch Adjustment

1. Loosen the lock nut on the latching stud. It is located directly behind the door handle.
2. Open the loading door.
3. Screw the door catch stud in or out as necessary and then retighten the lock nut.

Door Switch Removal And Installation

1. Each door switch is located directly behind the hinge plate of the loading door assembly.
2. The entire switch can now be pulled from the front panel opening.
3. The switch has two clips that hold it in place on the rear of the switch.
4. With the panel removed, you can now squeeze the two clips and allow switch to be pushed back through panel and grasped from the front and switch removed.

Installation Of Clothes Door Window And Gasket

1. Place the clothes door, with its face down, on a solid surface.

NOTE: Prewarming the gasket makes the installation much easier.

2. Install the window gasket on the clothes door flange. The wider lip of the gasket should be on the bottom side or front face of the clothes door and the ridges should be up.
3. Locate the seam at the latching stud.
4. Apply a soapy water solution or rubber lubricant to the gasket.
5. Slide the glass into the middle of the door ring and gasket with half of the glass above the door and half below.
6. While pressing down on the glass, stand the door up and use a modified screw driver with the end rounded off to install half of the glass. Lay the door down and install the other half.
7. At the six o'clock position, pry the glass up enough to install the black spacer. (reuse from old door gasket)

High Limit Thermostat Locations And Functions

A. Burner Housing- This hi-limit is located on the back side of each burner housing.

1. The thermostat opens the circuit to the main burners in the event of malfunction in the gas control area or temperature control. This thermostat will open quickly if there is a significant loss of air flow over the burner area.
2. It is covered by a guard and is held in place by two screws. There are spacers between the thermostat and bracket which must be used to give proper operation.

B. Manual Reset Over temperature Safety Thermostats- The manual over temp thermostat is located on the right side of each burner housing as you view from the back of the machine. It is just above the gas valve and covered by a guard with a small access hole.

1. The manually resettable thermostat limits the operating temperature a dryer can reach should some abnormal situation occur.

-
2. Should one of the thermostats be tripped, the tumbler will cease to heat until the thermostat is reset. Once the dryer cools, the thermostat may be reset by inserting a pencil or stick through the opening in the thermostat cover.

REMOVAL: To remove either the hi-limit thermostat on the rear of the burner housing or the over-temperature thermostat on the right side of the burner housing, remove the mounting screws holding its respective guard. Next, remove the terminal of each wires attached to the thermostat. Lastly, remove the mounting screws holding the thermostat to the burner.

Pressure Regulator Adjustment

Use the following procedure whenever it is necessary to check the pressure regulator setting.

NOTE: Any adjustment of the pressure regulator must be made with a manometer attached at the plug in the main burner manifold.

1. Shut off the gas supply to the dryer.
2. Remove the 1/8" pipe plug from the end of the main burner manifold.
3. Attach a manometer to the manifold end.
4. Remove the pressure regulator cover screw on the gas valve.
5. Open the shutoff valve, and operate the dryer.
6. Adjust the pressure for a manometer reading of 3.5" water column gas pressure. (11.0" for L.P.)

NOTE: The main burners must be operating when adjusting the pressure regulator.

7. Shut off the gas supply to the dryer. Remove the manometer and install the 1/8" pipe plug in the manifold.
8. Open the shut off valve, start the dryer and check for gas leaks while the burners are ignited.

Coin Acceptor Removal

Loosen the four screws (Torx #10 driver) mounting the coin acceptor to its retaining bracket.

Do not remove all of the screws or the retainer will fall behind the panel.

Shift the acceptor up and down to allow the retainer to slide through the panel opening. When removing, the bottom should be brought through the panel opening first. When reinstalling, the top should go in first.

Coin Switch Adjustment

The coin switch should click soon after the coin hits the operator wire. However there must be enough travel to allow the switch to reset once the coin has passed. Adjustment should be made by bending the wire very close to its attachment point.

Electronic Control Diagnostic Lights

The electronic control has 6 diagnostic lights to aid in service of the dryer. Each pocket has indicator lights for the motor circuit, door switch circuit, and the heat circuit. When the electronic control is carefully unlocked and moved forward these lights are visible on the circuit board. They are each labeled as to function indicated.

1. When either dryer door is closed, the appropriate door light on the computer should be illuminated indicating that the door is closed.
2. When either dryer is running, the appropriate motor light on the computer should be illuminated indicating that the computer is calling for the motor to operate.
3. When either dryer is calling for heat, the appropriate heat light on the computer should be illuminated indicating that the computer is calling for heat.

An example of their function would be troubleshooting a dryer pocket that did not heat.

1. Start the machine and insure that it did not heat.
2. Check the upper heat light and see if it is lit.

-
3. If the heat light is on, this would indicate that the computer was calling for heat and that it was not at fault. You would then go on to check the rest of the heat circuit.

Electronic Control Removal

Unlock the retaining lock in the control assembly. Slide the control out of the machine holding the control by the metal tray. There is enough wire length to allow removing the control tray from the machine before disconnecting the wires.

Membrane Switch Replacement

The control buttons are an adhesive membrane switch assembly which may be replaced separately. Slide the control out to gain access to disconnect the ribbon connector. The ribbon connector must be pushed solidly and squarely into its connector when connecting a new membrane switch.

Temperature Sensor / Thermistor

This unit takes the place of the regulating thermostat on a mechanical timer dryer. The Heat Sensor is a thermistor. The way these work is fairly simple. As the temperature goes up, the resistance in the thermistor (heat sensor) goes down. As the temperature drops, the resistance in the thermistor (heat sensor) goes up.

Temperature Sensor Testing

If the tumbler display shows an F1 or F2, that is an indication of possible temperature sensor problems for that tumbler. Before replacing a sensor, check the wires and connections of the sensor for damage. The sensor lead wires are very small and care should be used in routing and connecting them. The sensors are located under the tumbler and may be viewed by removing the lint screen. The temperature sensor should have between 30,000 ohms and 60,000 ohms resistance at room temperature if okay.

Temperature Testing

To check the temperature in the dryer tumbler, press and hold the upper or lower start button for the tumbler being checked and while holding the start button also press the temperature button for the temperature to be checked. The display will read out the current temperature.

Temperature Sensor Removal

Remove front panel upper. Once front panel is removed, reach through the right side and back into the area where the sensor is mounted and remove wire nuts to disconnect.

Upper Front Panel Removal

The loading door does not have to be removed to remove the front panels on this model.

1. Remove the left two screws with finish washers.
2. Remove the right two screws with finish washers, at this time the front panel is loose but connected by the harness to the door switch.

NOTE: Always remove power from the machine before changing drive belts or working with the drive system.

Final Drive Belt Replacement

To replace the final drive belt turn the cylinder slowly by hand and work the belt off of the large pulley.

Motor Drive Belt Replacement

To replace the motor drive belt the final drive belt should be removed as above. Cut the old motor belt and remove. The new motor drive belt fits inside of three of the four motor mounting bolts. To achieve this, remove these three bolts one at a time and slide the belt in past each in turn. In this way the motor is always supported by 3 bolts at any time.

NOTE: All drive belts are self adjusting.

Tumbler Pulley Removal And Installation

Remove the 1 1/2" nut and lock washer. Pull the pulley off the shaft. Watch for the locking key on the tumbler shaft. Upon installation, the tumbler nut should be torqued to 150 ft./lbs.

Intermediate Pulley And Tension Arm Removal

1. The intermediate pulley is retained with a snap ring. Remove the snap ring and the pulley slides off the shaft.
2. With the pulley off, there is access to the self adjusting tension arm assembly. The tension arm assembly may be removed by removing the snap ring that holds it to the tension arm support assembly pin. The arm assembly is replaced as a complete unit.
3. The grease fitting for the intermediate shaft should be greased monthly.

Tension Arm Support Assembly Adjustment

The tension arm support assembly may be adjusted for alignment of the intermediate pulley and also to align the belts. The three outer nuts allow the alignment of the pin to be adjusted by pivoting the assembly on the center bolt. The center bolt can be screwed in to allow bringing the complete assembly farther back if necessary for belt alignment.

Motor Blower Assembly Removal And Installation

1. Remove the motor wiring cover and take the 3 motor wires off.
2. Remove the 9 nuts and lock washers that retain the blower cover and set assembly out of dryer.
3. The blower is held in place with 2 square headed set screws. Upon reassembly, one blower set screw should fit in the counter sink in the shaft and the other set screw should go against the flat side of the shaft. Use red Loctite on the set screws and torque to 165 in./lbs.
4. The motor is mounted with 4 bolts to the motor mounting bracket on rear of dryer.

Air Flow Switch Operation And Adjustment

The air flow switch assembly is part of the ignition safety circuit and insures that the burners don't operate unless there is air flow. When the drive motor and blower are running the flat actuator is pulled in against the back of the dryer closing the switch. If this doesn't happen ignition will not occur. The air flow switch assembly is mounted by two screws through the bracket. It can be adjusted by loosening these mounting screws and moving the switch forward or backward.

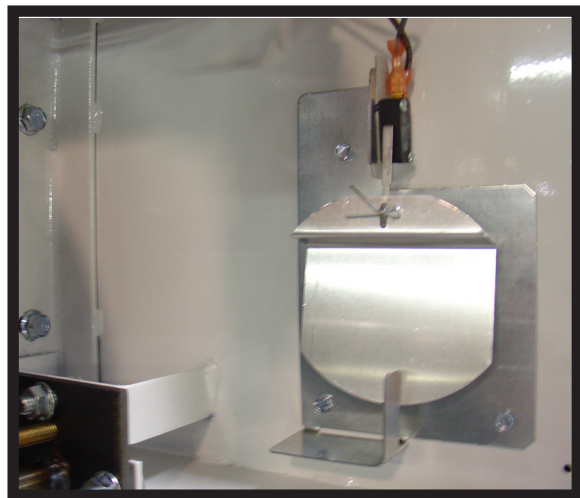

Ignition Transformer Fuse

The 1 1/2 amp fuse protects the ignition transformer. To remove it just twist and pull it out.

Ignition Control Transformer

When heat is called for, the ignition control transformer steps 120VAC down to 24VAC to power the ignition control.

Electronic Ignition Module

This machine uses an electronic spark ignition system to directly light the burners in each tumbler.

1. The electronic ignition module for the tumbler is located inside the electrical box. This is the metal box on the back of the tumbler area directly to the right of the final drive pulley.
2. The red wire from the transformer traveling thru the 1.5 amp fuse and into the module supplies the 24VAC required to operate the entire direct ignition system.
3. The black colored hi-voltage wire (spark plug type) plugs onto the post connector on the module, and the multi-wire plug fits into the side of the module.

Spark Ignition Module Removal

If the ignition modules are mounted on a bracket, see section A. Otherwise, see section B.

A: With mounting bracket

Remove the connector housing of the wiring harness attached to the ignition module. Then, remove the terminal of the hi-voltage cable attached to the ignition module. Next, remove the mounting screws holding the ignition module mounting bracket in the rear control box. Lastly, remove the nuts holding the ignition module on its mounting bracket.

B: Without mounting bracket

Remove all of the terminals of the wiring harness attached to the ignition module. Then, remove the terminal of the hi-voltage cable attached to the ignition module. Lastly, remove the mounting screws holding the ignition module in the control box. If there is no spark or intermittent spark, check black hi-voltage lead wire for damage

NOTE: Proper grounding of the ignition system (yellow wires) is very critical for proper ignition sequence.

Ignition System-Function & Sequence

During normal dryer operation, the following occurs:

1. The dryer electronic control calls for heat.
2. If the drive motor is running, the motor safety circuit provides power to the electronic control. If the control senses that the heat should be on, a circuit is closed allowing power through the high limit thermostat and air flow switch to the ignition transformer. The transformer provides 24VAC to the ignition module and sparking occurs at the ignition electrode. At the same time 24VAC is applied to the gas valve.
3. Once the flame is established, the sensing electrode detects the presence of flame and the sparking stops.
4. If for any reason the flame is not established in

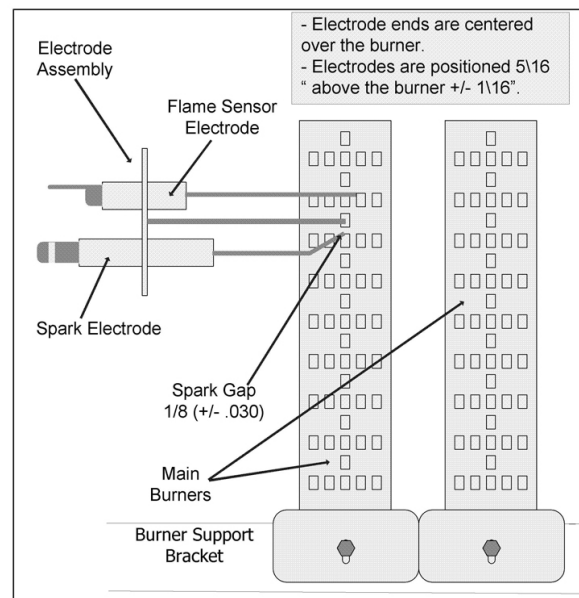

a period of 10 seconds, the electronic control will try this sequence for 3 tries. Normally the 10 seconds "Trial For Ignition" period is ample to establish and prove flame.

5. If the flame is shutdown or blown out during operation, the ignitor will immediately go into "Trial For Ignition" again for 10 seconds.
6. However, at the end of 3 separate retries of 10 seconds "Trial for Ignition", the flame is not established, the ignition system goes into "Safety Lock-Out" and will not reactivate the "Trial for Ignition" until there is a current interruption for a period of 15 seconds. This interruption can be provided by opening the dryer loading door and allowing the machine to come to a complete stop for 15 seconds.

Ignition System-Checkout

1. If flame is present during "Trial For Ignition" period but the system shuts down, there may be an improper ground. The entire ignition system is grounded together including the electrode assembly, the electrode mounting bracket, the burners and the burner bracket. Shutdown can also occur if for some reason the system isn't sensing the flame. Check the sensor for damage and check the connections of the sensor lead.
2. If there is no spark or intermittent spark, check black hi-voltage lead wire for damage or cracks in insulation. (This lead wire must not be taped or connected to any metal edges along its length to prevent pinching and arcing. Also, do not bundle this wire with other wires.)

NOTE: Spark gap and electrode location are important. If the electrode is damaged or mounting is changed the spark gap may not be correct for ignition to occur. Check for cracks in the ceramic insulator. Replace electrode assembly if necessary. Also check for carbon or foreign material on the electrodes and clean if necessary.

Spark Electrode Assembly-Removal

1. Remove electrode cover and disconnect wires to electrodes.
2. Remove two screws to detach electrode assembly.

Gas Valve Removal (shut off manual gas valve to stop gas flow before removing gas control valve)

1. Disconnect union at gas valve and disconnect wires from gas valve operator coils.
2. Remove right manifold mounting bracket screws and slide manifold to remove from left bracket.

Main Burner Orifice Removal

1. Remove manifold and gas valve assembly as above.
2. Using an open end wrench, remove orifices from manifold.

Main Burner Removal

1. Remove the 4 screws securing the cover for the burner housing and the one screw mounting the high limit cover. With the burner housing cover removed, there is complete access to the burner assemblies.

Recirculation Chamber Inspection

1. Remove Resettable manual overtemp sensor and remove inspection plate in burner chamber between main burners and rear back panel of dryer.

Cylinder Removal

1. Remove the front panel in front of the cylinder.
2. Remove drive belt, pulley, and key from cylinder shaft.
3. Pull the cylinder from the front of the machine.

Adjustment Of Cylinder Assembly With Front Panel Removed

1. Loosen the two top adjusting bolts and two bottom adjusting nuts and lock nuts holding the bearing housing to the drive plate.
2. Loosen the four mounting bolts on the side channels.
3. Open the clothes door and insert a 1/4" thick shim at the 3 and 9 o'clock positions and a 1/8" thick shim at the 6 o'clock position.
4. Tighten the two bottom adjusting nuts and tighten locking nuts.
5. Tighten the bottom right mounting bolt, then the top left mounting bolt. Tighten the remaining two bolts. (Shim where and if necessary.)
6. Tighten the two top adjusting bolts.
7. Remove all the shims from between the front panel flange and cylinder (3, 6, and 9 o'clock).8. Spin the cylinder to check for rubbing baffles, pressing down hard while rotating. If rubbing is detected, repeat procedure paying particular attention to placement of shims between bearing housing and side channels.

Tumbler Through Bolt Access Cover

Remove 4 screws that mount the air flow switch to the back of the dryer. Remove 2 screws that retain access cover. With access cover removed, tightness on the tumbler through bolts can be checked and tumbler alignment can be adjusted.

Bearing Housing Removal

After removing cylinder as previously outlined, simply unbolt the bearing housing and remove.

Dryer Trouble Shooting

Electronic Control Diagnostic Lights

The electronic control has 3 diagnostic lights to aid in service of the dryer. Each pocket has indicator lights for the motor circuit, door switch circuit, and the heat circuit. When the electronic control is carefully unlocked and moved forward these lights are visible on the circuit board. They are each labeled as to function indicated.

1. When dryer door is closed, the door light on the computer should be illuminated indicating that the door is closed.
2. When dryer is running, the motor light on the computer should be illuminated indicating that the computer is calling for the motor to operate.
3. When dryer is calling for heat, the heat light on the computer should be illuminated indicating that the computer is calling for heat.

An example of their function would be troubleshooting a dryer pocket that did not heat.

1. Start the machine and insure that it did not heat.
2. Check the heat light and see if it is lit.
3. If the heat light is on, this would indicate that the computer was calling for heat and that it was not at fault. You would then go on to check the rest of the heat circuit.

Electronic Control Test Cycle

This test cycle allows the dryer to run for 5 minutes without the need for adding money while servicing. To actuate this 5 minute test cycle leave the loading doors closed, unlock the computer and push the program button on the right front corner of the computer as if you were putting it into the program mode. This will give a 5 minute cycle on both tumblers for evaluating the machine.

Trouble Shooting Fault Codes

- F1 Shorted sensor or shorted sensor wire harness
- F2 Open sensor or sensor wire harness disconnected
- F3 Possible grounding problem. Try powering down and repowering and then push programming button to start dryer. Try resetting with Palm Pilot (extra utilities file). If no success. Try removing battery and reinstall battery.
- F4 Micro Chip Problem. Replace controller.
- F5 Microchip Electrical Problem. Remove power for 1 minute and then power on. Try removing battery and reinstalling on control PCB/

Troubleshooting Tips

Symptom	Probable Cause	Suggested Remedy
Tumbler does not turn	Drive belts	Check both drive belts. Replace if failed.
	Drive motor	Check capacitor and motor. Replace if failed
	Door switch	Check door switch contacts and adjustment. Adjust or replace door switch.
	Electronic Control	Is electronic control closing motor relay to power drive motor? Check for motor light on electronic control. If no light change control. If light is on, check voltage and wiring to motor.

Symptom	Probable Cause	Suggested Remedy
Tumbler turns but no spark at burner	Glass fuse	Check small glass control fuse in back of dryer. Replace if failed.
	Temperature Sensor	The temperature sensor should have between 30,000 ohms and 60,000 ohms resistance at room temperature if okay. Replace if not in this range.
	Ignition	Check for 24VAC output from transformer.
	Transformer	Replace if have 120V between black & white and no 24V between red and yellow.
	Over temperature	Check to see if manually resettable thermostat. Thermostat is kicked out. Reset by pushing red reset button.
	Ignition control	Check for 24VAC coming into the control on the at burner red wire. If voltage, then check for 24VAC out on the brown wire. Also check for spark at the ignitor. If no 24VAC output or no spark to the ignitor, replace ignition control.
	Air Flow Switch	Check air flow switch to be sure it closes when dryer is running. If not, adjust or replace switch.
	Hi-limit	Check for continuity. Should be 0 ohms resistance when cold. If not, replace thermostat.
	Gas supply	No gas can cause system lockout
	Electronic Control	Is electronic control closing gas relay to power Control heat circuit? Check for gas light on electronic control. If no light change control. If light is on, check voltage and components in heat circuit at transformer at rear of unit.
Tumbler turns, ignition sparks, no flame	Gas supply	Make sure gas supply is working.
	Gas pressure	Make manometer check of gas pressure. Adjust if necessary.
	Spark Electrode Sensor	Check for damage to electrode or mounting. Replace if necessary.
	Gas valve	Check coil continuity, replace valve if failed.
	Ignition Control	Check for 24VAC to gas valve coils. If no voltage replace ignition control.

Symptom	Probable Cause	Suggested Remedy
Burner Lights, but goes on and off	Electrodes	Check low voltage harness for possible wire break or cuts to allow no signal back to ignition control
Slow drying	Temperature Setting	Check program for correct high temperature setting. Adjust if necessary.
	Air flow restrictions necessary	<ol style="list-style-type: none"> 1. Check lint screen and clean if necessary. 2. Check exhaust for correct length and clean if necessary. 3. Check exhaust damper to insure that it opens when dryer is running and closes when dryer is not in use. 4. Check makeup air to insure that it is adequate. Increase makeup air if necessary. 5. Check static Back pressure no more than .3
	Temperature Sensor	The temperature sensor should have between 30,000 ohms and 60,000 ohms resistance at room temperature if okay. Replace if not in this range.
Erratic display	Initial Start-up	If erratic on initial start-up, leave power on for approximately one hour and check machine operation again.
	Grounding	Machine must be grounded by separate conductor back to neutral bar in breaker box.
	Program	Check program and make corrections if necessary.
	Voltage spike	Power down machine for 20 seconds and repower. If no improvement, replace control.
Manual overtemp Tripping Frequently	Recirculating chamber Lint Accumulation	Remove manual overtemp thermostat and inspect in chamber for excessive lint build up. Access also gained to this chamber by removing recirculation duct mounted at bottom of chamber, or the panel inside burner chamber between burners and rear back panel
	Exhaust ducting Excessive lint buildup	Remove exhaust duct at rear of dryer and inspect for excessive lint build up in complete duct from dryer to where duct exits building.
	Clean lint of of top heat air chamber above tumbler	Remove front panel completely. Be careful of any wiring attached. Remove heated air chamber cover and clean above tumbler back to burner housing.

Wiring Schematic for Electronic Acceptor Dryer

CONNECT TO 120V-1PH-60HZ POWER SOURCE.
POWER SOURCE GROUNDING CONDUCTOR MUST
BE CONNECTED TO DRYER GROUNDING SCREW.

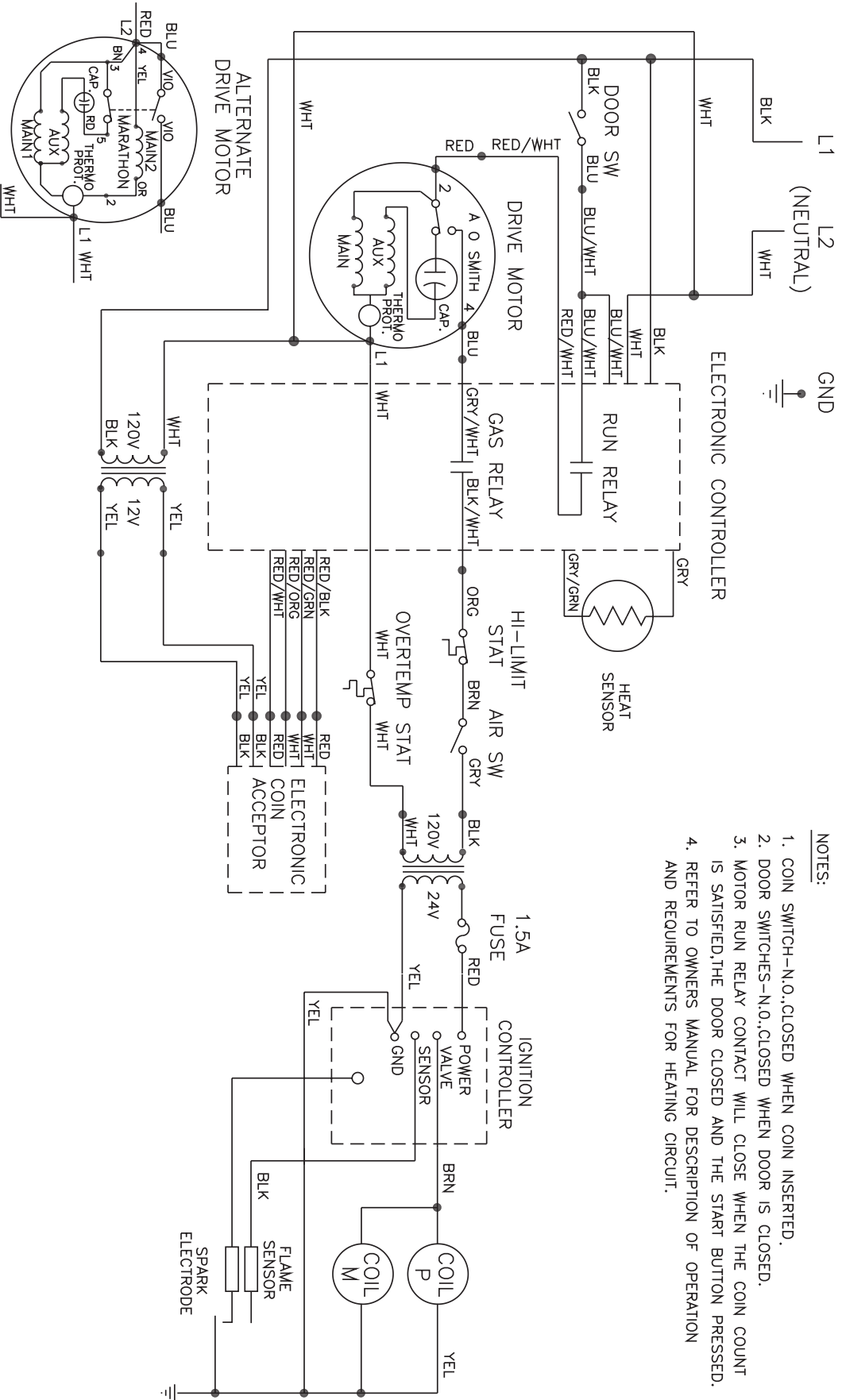

- NOTES:
1. COIN SWITCH-N.O.CLOSED WHEN COIN INSERTED.
 2. DOOR SWITCHES-N.O.CLOSED WHEN DOOR IS CLOSED.
 3. MOTOR RUN RELAY CONTACT WILL CLOSE WHEN THE COIN COUNT IS SATISFIED.THE DOOR CLOSED AND THE START BUTTON PRESSED.
 4. REFER TO OWNERS MANUAL FOR DESCRIPTION OF OPERATION AND REQUIREMENTS FOR HEATING CIRCUIT.

9506-098-001A

SCHEMATIC

D_T_30KCS-10CP

Wiring Diagram for Electronic Acceptor Dryer -10Cp

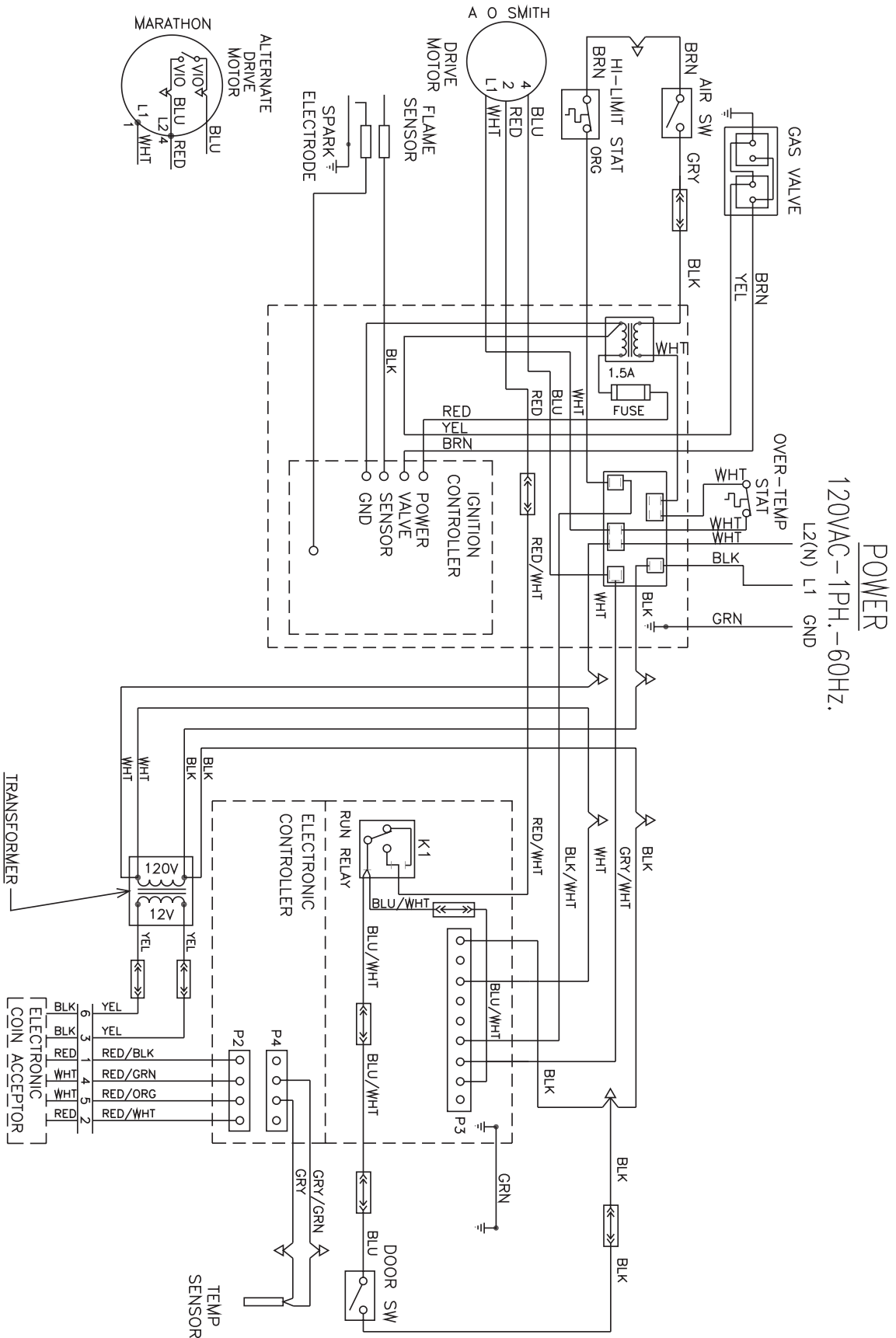

9506-099-001A

WIRING DIAGRAM

D_I_30KC-10CP

Wiring Schematic for Easy Card Dryer

CONNECT TO 120V-1PH-60HZ POWER SOURCE.
POWER SOURCE GROUNDING CONDUCTOR MUST
BE CONNECTED TO DRYER GROUNDING SCREW.

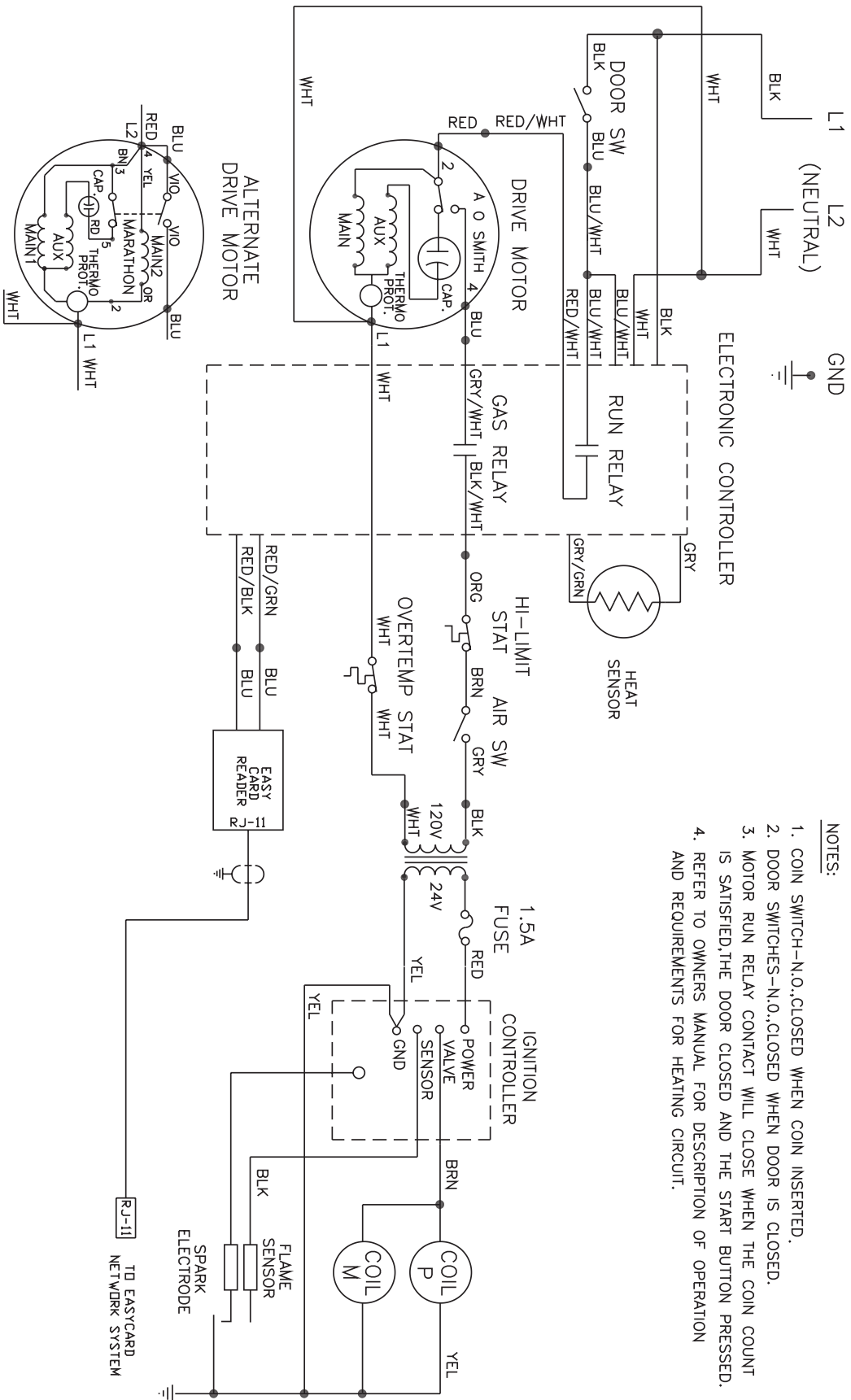

- NOTES:
1. COIN SWITCH-N.O.,CLOSED WHEN COIN INSERTED.
 2. DOOR SWITCHES-N.O.,CLOSED WHEN DOOR IS CLOSED.
 3. MOTOR RUN RELAY CONTACT WILL CLOSE WHEN THE COIN COUNT IS SATISFIED,THE DOOR CLOSED AND THE START BUTTON PRESSED.
 4. REFER TO OWNERS MANUAL FOR DESCRIPTION OF OPERATION AND REQUIREMENTS FOR HEATING CIRCUIT.

9506-148-001A

SCHEMATIC

D_T_30KC_10EC

Wiring Diagram for Easy Card Dryer

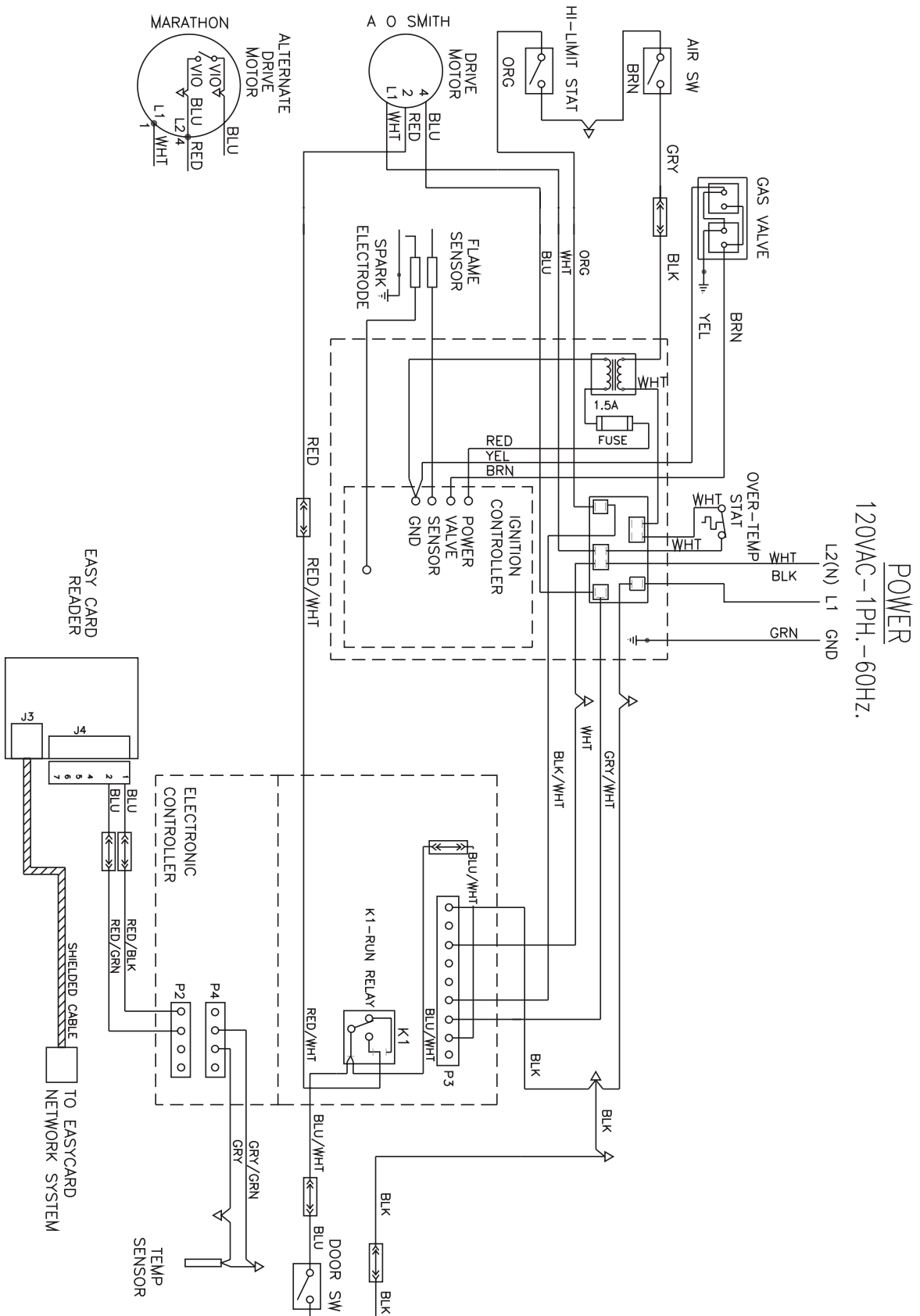

9506-149-001A

WIRING DIAGRAM

D_T_30KC_10EC

Kits, Assemblies, & Common Parts

Description	Model
Kit - 8650-012-003 Lock with spacer	9732-344-001
Kit - T450 SWD Dryer Mounting Kit	9732-339-001
Kit - A to C series Conversion, SWD Dryer, Black, 24v	9732-312-004
Kit - A to C series Conversion, SWD Dryer, Blue, 24v	9732-312-003
Lock with Spacer Replacement for 8650-012-003	9732-344-001
30lb SWD Makeup Air Kit	9732-333-001
Cleanout Duct Assembly 8"	9973-034-001
Temperature Probe	9501-004-003
Controls Blue	9857-148-001
Controls Black	9857-148-009
Coin Drop	9021-009-001
Coin Drop Switch/Optical Sensor	9539-466-005
Coin Drop Screws	9545-053-002 x4
Ignition Control (Before Serial #232998)	9857-116-003
Ignition Control (After Serial #232998)	9857-182-001
Electrode Assembly, Ignition	9875-002-003
Thermostat, Hi-Limit	9576-203-002
Thermostat, Overtemp	9576-207-008
Fuse	9200-001-002
Fuseholder	8636-018-001
Transformer, Ignition	8711-011-001
Lint Screen Assy w/o Front	9805-029-002
Air Flow Switch	9536-461-009
Door Switch	9539-487-001
Motor Belt	9040-073-009
Tumbler Belt	9040-077-001
Tension Arm Complete	9861-022-001
Spider/Trunnion	9568-011-001
Door Handle	9244-082-001

Section 5:

Dryer Parts Data

Dryer Cabinet Group Before Serial # 232998

Key	Description	Part Number	Qty
1	Loading Door Complete SS/Brushed SS/Gray	9960-256-030	1
1	Loading Door Complete SS/Chrome/Blk	9960-256-037	1
2	Door Assy, Loading (Ring only) Brushed SS	9960-255-008	1
2	Door Assy, Loading (Ring only) Chrome	9960-255-016	1
3	Plate Assy, Hinge (SS)	9982-280-011	1
4	Screw Hinge to Door	9545-012-015	4
*	Nut, Hinge to Door	8640-413-002	4
5	Glass, Door	9212-002-003	1
6	Gasket, Door Glass (Gray)	9206-164-009	1
6	Gasket, Door Glass (Black)	9206-413-001	1
*	Support Door Glass	9548-117-000	2
7	Gasket, Door Outer Rim (Gray)	9206-420-002	1
7	Gasket, Door Outer Rim (Black)	9206-420-003	1
8	Handle, Loading Door	9244-082-001	1
*	Screw, Handle	9545-018-017	2
*	Stud Door Catch	9531-033-001	1
*	Nut-Hex, #10-32	8640-413-001	1
*	Nut, Acorn	8640-413-003	1
*	Catch, Loading Door	9086-015-002	1
9	Strap, Hinge (Gray)	9544-047-007	1
9	Strap, Hinge (Black)	9544-047-011	1
10	Screw, Hinge to Door	9545-052-001	1
11	Washer-Fiber/Plastic	8641-436-003	1
12	Front Pannel Assy	9989-465-001	1
*	Insulation-Front Panel, Top Half	9277-053-001	1
*	Insulation-Front Panel, Bottom Half	9277-053-002	1
13	Name Plate-Dryer, SWD	9412-102-001	1
14	Escutcheon-Dryer Coin	9141-154-001	1
*	Screw-TRHD Torx, 6BSDx1/2,BLK	9545-031-009	10
15	Overlay-Escutcheon, Coin WSD w/ Holes	9435-009-001	1
15	Overlay-Escutcheon, Coin WSD w/o Holes	9435-009-003	1
16	Lock & Key Assy	8650-012-003	1
*	Key, Electronic Control (6324)	6292-006-007	1
*	Cam-Lock	9095-041-001	1
*	Washer-Flat Shim	8641-581-010	1
*	Washer-Flat	8641-581-041	1
*	Cabinet Touch Up Paint (White)	9472-001-013	1

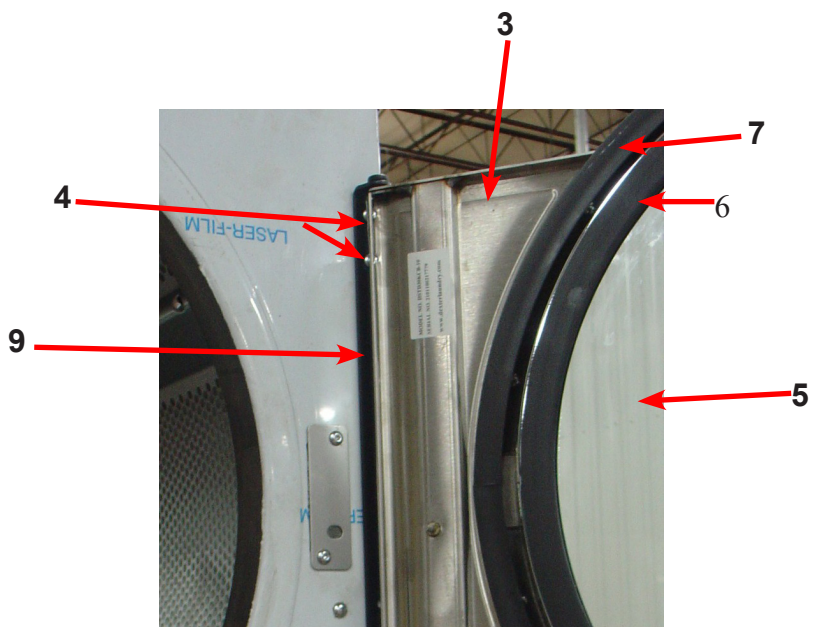

Dryer Cabinet Group After Serial #232998

Key	Description	Part Number	Qty
1	Loading Door Complete SS/Brushed SS/Gray	9960-256-030	1
1	Loading Door Complete SS/Chrome/Blk	9960-256-035	1
2	Door Assy, Loading (Ring only) Brushed SS	9960-255-008	1
2	Door Assy, Loading (Ring only) Chrome	9960-255-016	1
3	Plate Assy, Hinge (SS)	9982-280-012	1
4	Screw Hinge to Door	9545-012-028	4
*	Nut, Hinge to Door	8640-413-002	4
5	Glass, Door	9212-002-003	1
6	Gasket, Door Glass (Gray)	9206-164-009	1
6	Gasket, Door Glass (Black)	9206-413-001	1
*	Support Door Glass	9548-117-000	2
7	Gasket, Door Outer Rim (Gray)	9206-420-002	1
7	Gasket, Door Outer Rim (Black)	9206-420-003	1
8	Handle, Loading Door	9244-082-001	1
*	Screw, Handle	9545-018-017	2
*	Stud Door Catch	9531-033-001	1
*	Nut-Hex, #10-32	8640-413-001	1
*	Nut, Acorn	8640-413-003	1
*	Catch, Loading Door	9086-015-002	1
9	Strap, Hinge (Gray)	9544-047-007	1
9	Strap, Hinge (Black)	9544-047-011	1
10	Screw, Hinge to Door	9545-052-001	1
11	Washer-Fiber/Plastic	8641-436-003	1
12	Front Pannel Assy	9989-465-001	1
*	Insulation-Front Panel, Top Half	9277-053-001	1
*	Insulation-Front Panel, Bottom Half	9277-053-002	1
13	Name Plate-Dryer, SWD (Blue)	9412-102-001	1
13	Name Plate-Dryer, SWD (Black)	9412-202-001	1
14	Escutcheon-Dryer Coin	9141-154-001	1
*	Screw-TRHD Torx, 6BSDx1/2,BLK	9545-031-009	10
15	Overlay-Escutcheon, Coin SWD (Blue) W/Holes	9435-009-001	1
15	Overlay-Escutcheon, Coin SWD (Blue) W/o Holes	9435-009-003	1
13	Overlay-Escutcheon, Coin SWD (Black)	9435-035-001	1
16	Lock & Key Assy	8650-012-003	1
*	Key, Electronic Control (6324)	6292-006-007	1
*	Cam-Lock	9095-041-001	1
*	Washer-Flat Shim	8641-581-010	1
*	Washer-Flat	8641-581-041	1
17	Cover-Hinge, Black	9074-341-002	1
18	Screws-TRHDCR, 10B x 3/8, Black	8636-018-001	2
*	Cabinet Touch Up Paint (White)	9472-001-013	1

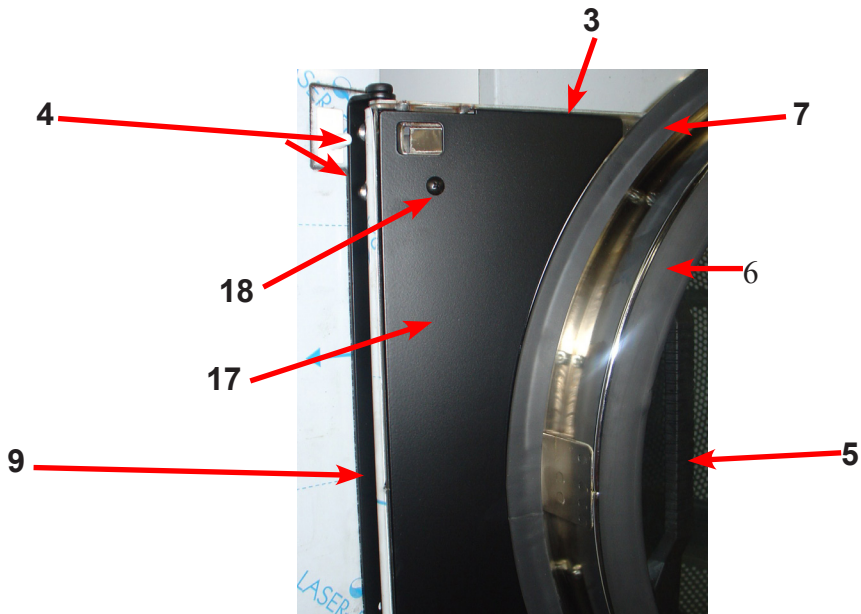
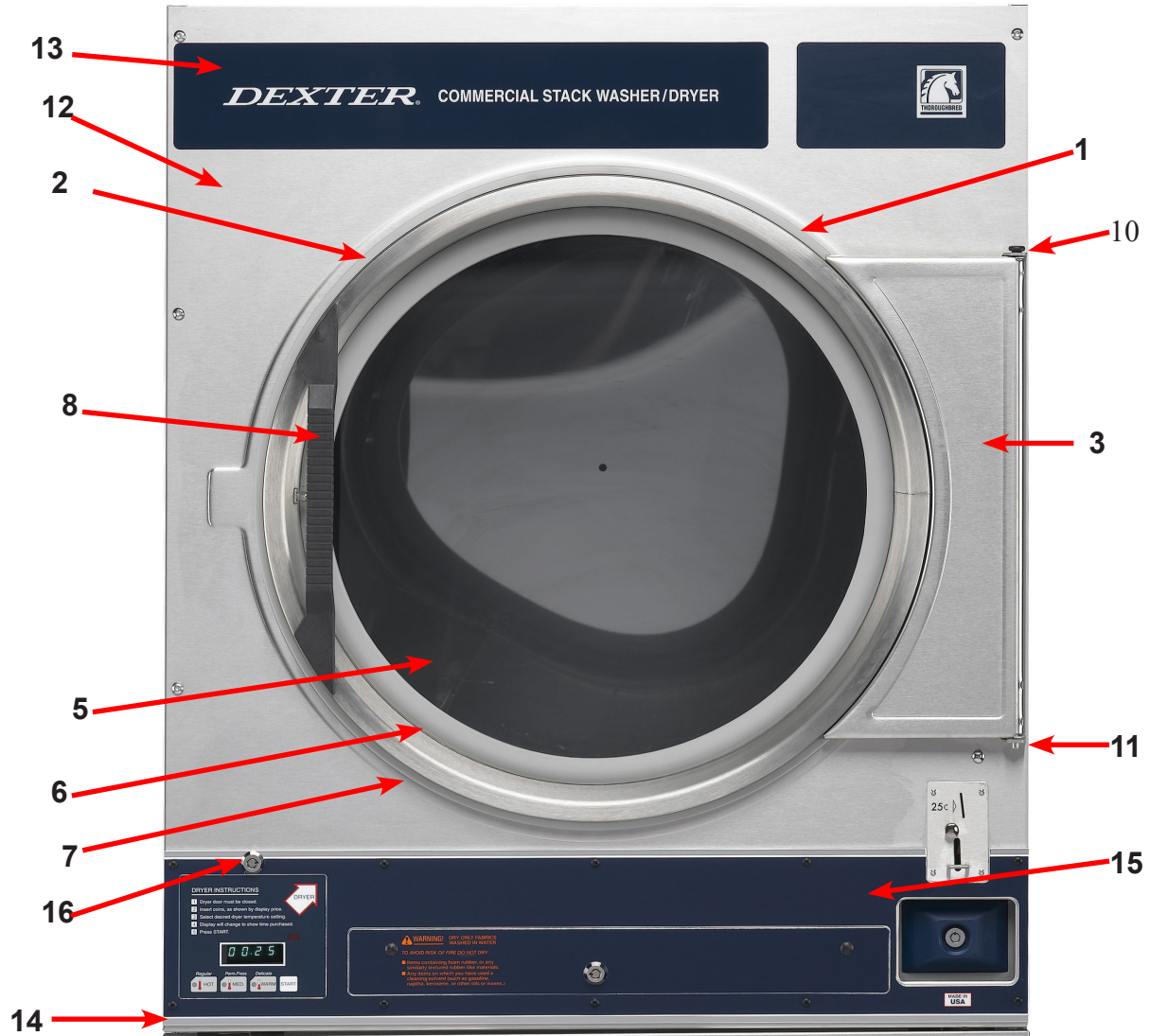

Dryer Cabinet Group Continued Before Serial #232998

Key	Description	Part Number	Qty
1	Control Assy-Stach Washer Dryer W/IR	9857-148-001	1
	Membrane Switch	9801-076-001	1
2	Lint Drawer Assy Complete W/Front	9866-004-001	1
*	Lint Screen Assy w/o Front	9805-029-002	1
*	Lint Drawer Front (Aluminum)	9974-010-001	1
3	Overlay, Lint Drawer	9435-003-009	1
*	Screen (Course)	9555-057-002	1
*	Screen (Fine Mesh)	9555-057-003	1
*	Felt-Seal (back of lint screen)	9532-074-003	1
*	Screw-Lint screen strap hold down	9545-008-001	14
4	Lock & Key Assy	8650-012-004	1
*	Key (6101)	6292-006-010	1
*	Cam, Lock	9095-043-001	1
*	Washer	8641-581-041	1
5	Door Switch	9539-461-001	1
5	Shield-Door Switch	9550-159-001	1
5	Box-Door Switch	9041-076-002	1
5	Screw- 4-40x5/8	9545-020-001	2
5	Twin Nut Special	8640-401-001	1
5	Acuator-Door Switch	9008-004-002	1
5	Cover-Switch Box	9074-255-001	1
6	Screw-TRHDTORX, 10ABx3/4	9545-008-020	2
*	Gromet, 1/4	9029-037-001	1
*	Conduit - Special	6068-043-001	1
*	Wire-BLK, 45"	8220-001-221	1
*	Wire-BLU, 45"	8220-001-222	1
*	Bracket Assy, Temp Sensor	9985-175-001	1
7	Temp Sensor	9501-004-003	1
*	Gromet	9209-037-002	1
*	Wire-Nut Gray	8640-276-002	2
*	Harness-Main Harness	9627-782-001	1
*	Harness-Door & Coin Switches	9627-783-001	1
*	Cabinet Cover	9074-261-001	1
*	Insulation, Cabinet Cover	9277-041-011	1
*	Coin Vault Assy (Black)	9942-027-015	1
*	Screw - #10Bx1/2	9545-008-026	4
8	Coin Box (Blue Front)	9807-099-001	1
9	Coin Acceptor	9021-009-001	1
*	Switch, Coin Mech	9539-466-005	1
*	Return, Coin Acceptor	9486-145-001	1
*	Screw, Retainer	9545-053-002	4

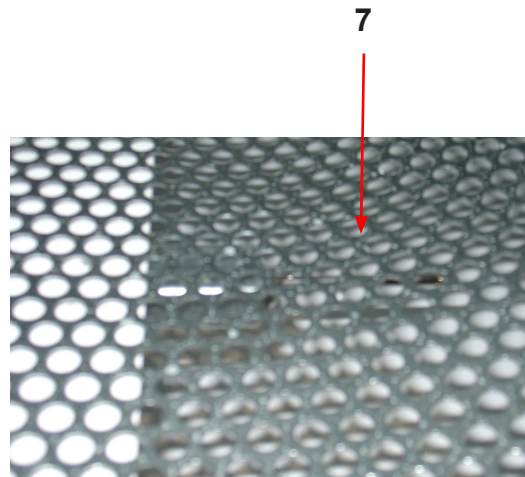
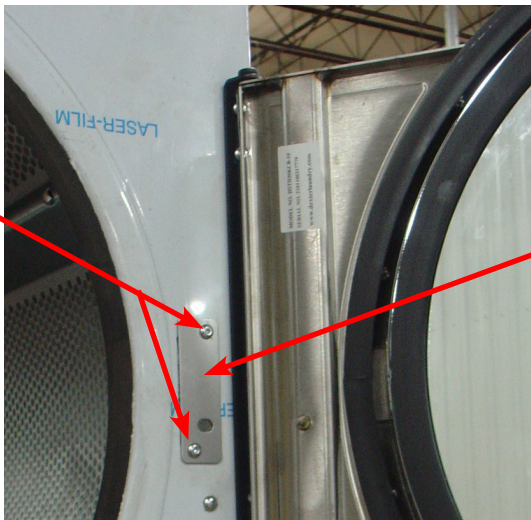

Dryer Cabinet Group Continued After Serial #232998

Key	Description	Part Number	Qty
1	Control Assy-Stach Washer Dryer W/IR (Blue)	9857-148-001	1
1	Control Assy-Stach Washer Dryer W/IR (Black)	9857-148-009	1
*	Membrane Switch (Blue)	9801-076-001	1
*	Membrane Switch (Black)	9801-109-001	
2	Lint Drawer Assy Complete W/Front (Blue)	9866-004-001	1
2	Lint Drawer Assy Complete W/Front (Black)	9866-004-011	
*	Lint Screen Assy w/o Front	9805-029-002	1
*	Lint Drawer Front (Aluminum)	9974-010-001	1
3	Overlay, Lint Drawer (Blue)	9435-003-009	1
3	Overlay, Lint Drawer (Black)	9435-029001	
*	Screen (Course)	9555-057-002	1
*	Screen (Fine Mesh)	9555-057-003	1
*	Felt-Seal (back of lint screen)	9532-074-003	1
*	Screw-Lint screen strap hold down	9545-008-001	14
4	Lock & Key Assy	8650-012-004	1
*	Key (6101)	6292-006-010	1
*	Cam, Lock	9095-043-001	1
*	Washer	8641-581-041	1
5	Door Switch	9539-487-001	1
*	Bracket Assy, Temp Sensor	9985-175-001	1
7	Temp Sensor	9501-004-003	1
*	Gromet	9209-037-002	1
*	Wire-Nut Gray	8640-276-002	2
*	Harness-Main Harness	9627-782-002	1
*	Harness-Door & Coin Switches	9627-783-003	1
*	Cabinet Cover	9074-261-001	1
*	Insulation, Cabinet Cover	9277-041-011	1
*	Coin Vault Assy (Black)	9942-027-015	1
*	Screw - #10Bx1/2	9545-008-026	4
8	Coin Box (Blue Front)	9807-099-001	1
8	Coin Box (Black Front)	9807-099-003	1
9	Coin Acceptor	9021-009-001	1
*	Switch, Coin Mech	9539-466-005	1
*	Return, Coin Acceptor	9486-145-001	1
*	Screw, Retainer	9545-053-002	4
*	Nut, Elastic Stop	8640-413-004	*

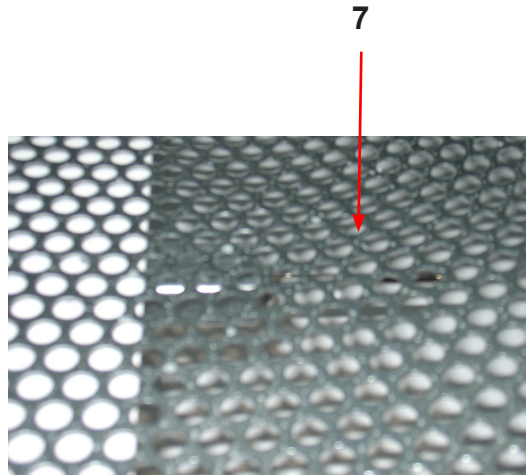

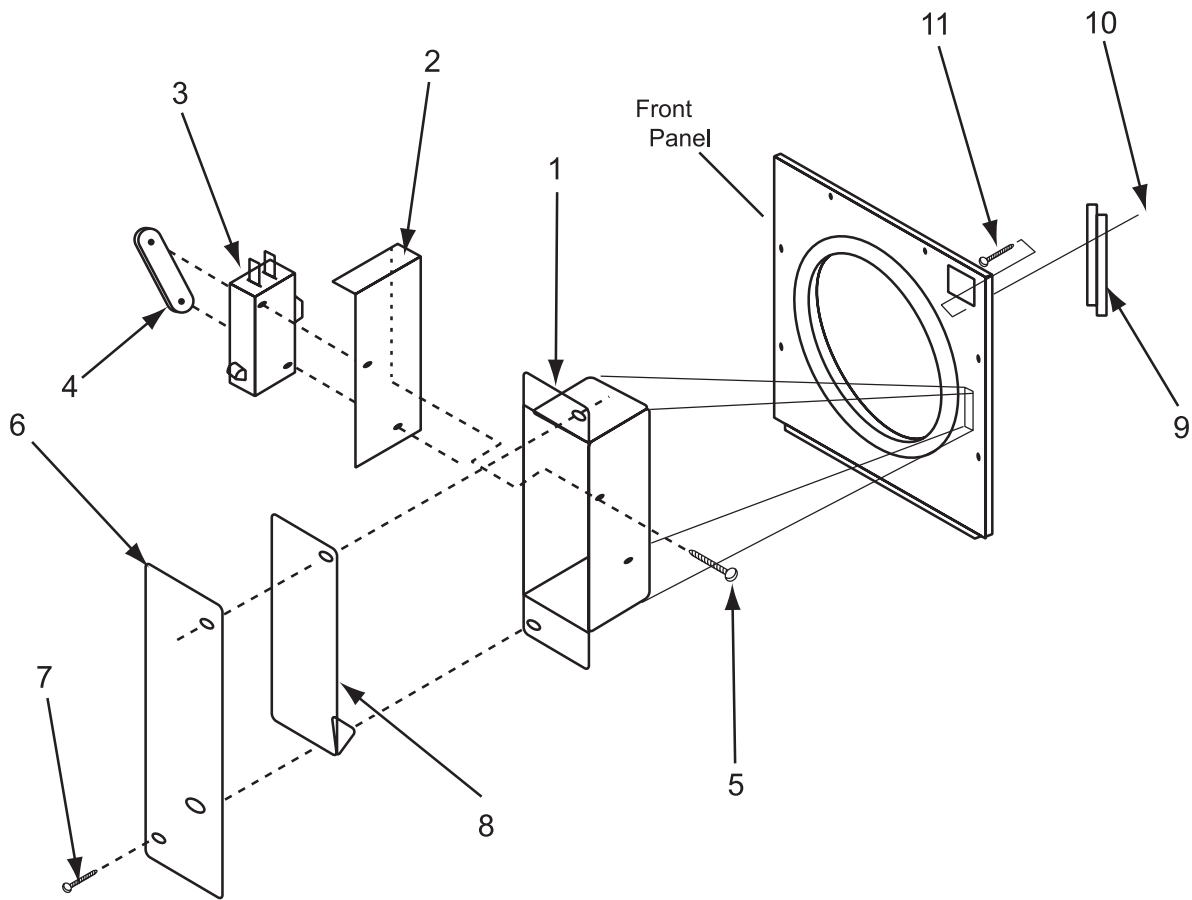

Key	Description	Part Number	Qty
1	Box-Door Switch	9041-076-002	1
2	Shield-Door Switch	9550-159-001	1
3	Door Switch	9539-461-001	1
4	Twin Nut Special	8640-401-001	1
5	Screw- 4-40x5/8	9545-020-001	2
6	Cover-Switch Box	9074-255-001	1
7	Screw-TRHDTORX, 10ABx3/4	9545-008-020	2
8	Acuator-Door Switch	9008-004-002	1
9	Conduit - Special	6068-043-001	1
10	Screw, 10-32x1/2	9545-012-003	1
11	Nut, Elastic Stop 10-32	8640-413-004	1
*	Gromet, 1/4	9029-037-001	1
*	Wire-BLK, 45"	8220-001-221	1
*	Wire-BLU, 45"	8220-001-222	1

Dryer Back Panels and Guards

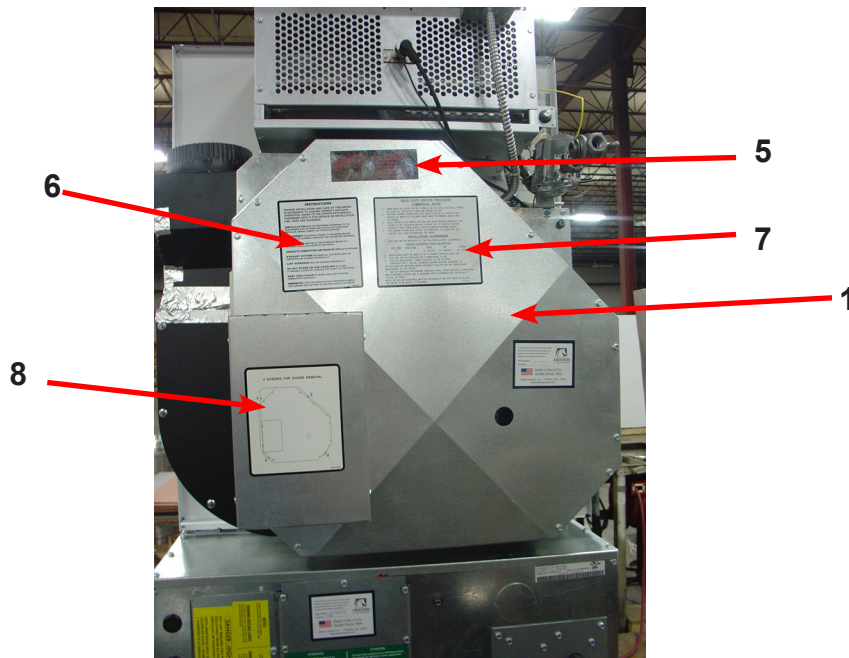
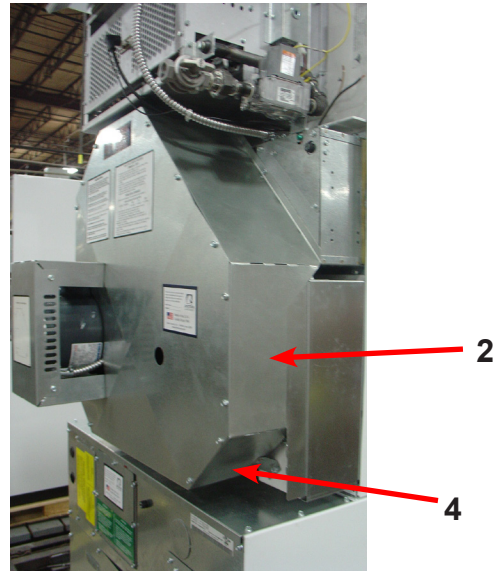
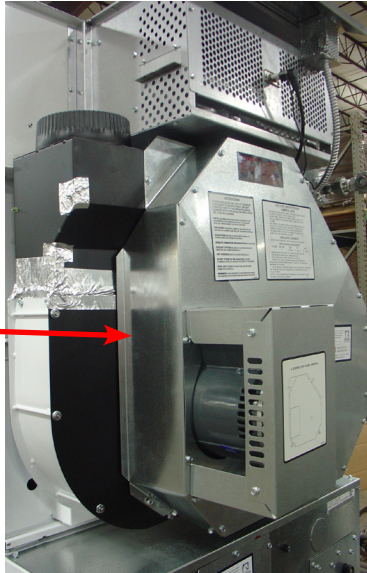

Key	Description	Part Number	Qty
1	Guard, Drive	9208-064-001	1
2	Panel, Drive Guard, LH Before Serial #232998	9454-740-001	1
	Panel, Drive Guard, LH After Serial#232998	9454-887-001	1
3	Panel, Drive Guard, RH	9989-481-001	1
4	Panel, Drive Guard Bottom	9454-739-001	1
*	Screw	9545-008-024	8
5	Warning, Lable	8502-600-001	1
6	Lable, Instructions	8502-645-001	1
7	Lighting and Clearence, Lable	8527-112-001	1
8	Lable, Guard Removal	8502-710-001	1

Dryer Burner Housing Group Before Serial #232998

Key	Description	Part Number	Qty
*	Housing Assembly, Burner	9803-199-001	1
1	Panel-Burner Housing Front & Back	9454-831-001	1
*	Panel-Burner Housing, Side Left	9454-789-001	1
2	Panel-Burner Housing, Side Right	9454-790-001	1
*	Baffle-Burner Housing	9049-080-001	1
*	Connector Assembly- Burner	9828-015-001	1
3	Panel-Burner Housing, Top	9454-791-001	1
4	Cover Burner Housing, Top	9074-307-001	1
*	Screw, 10Bx1/4	9545-008-001	4
*	Screw, 10ABx3/8	9545-008-006	23
*	Plate, Recirculation Cover	9452-729-001	1
*	Screw, 10Bx1/4	9545-008-001	6
*	Shield, Burner Inlet	9550-173-001	1
*	Screw, 10ABx3/8	9545-008-024	3
5	Burner, Main	9048-020-001	2
*	Panel- Burner Housing, Back	9454-816-001	1
*	Screw, 10Bx1/4	9545-008-001	4
6	Electrode-Ignition	9875-002-003	1
*	Screw, 8Bx1/4	9545-045-001	2
7	Thermostat-HI-Limit	9576-203-002	1
*	Bracket-Hi-Limit	9029-192-001	1
*	Spacer-Hi-Limit	9538-142-001	2
*	Screw, 8Bx3/4	9545-045-007	2
*	Wire Assy-BRN, 31"	8220-001-415	1
*	Wire Assy-ORG, 31"	8220-095-018	1
*	Thermostat-Over Temp, Manual Reset	9576-207-008	1
*	Screw, 10ABx3/8	9545-008-006	2
*	Bushing, Over Temp	2114-008-000	2
8	Cover Assembly, OverTemp Thermostat	9825-057-002	1
*	Screw, 10ABx3/8	9545-008-006	2
9	Control Assy,Gas Valve	9857-134-001	1
10	Manifold Assy	9381-009-001	1
*	Orfice-Natural, #32	9425-069-009	2
*	Orfice-LP, #50	9425-069-008	2
11	Bracket-Manifold, Gas	9029-047-001	1
12	Bracket-Control	9039-915-001	1
12	Bracket-Support, Gas Valve	9029-116-001	1
*	Elbow- 1/2x90, Black Iron	8615-104-037	2
*	Nipple- 1/2x2, Black Iron	8655-073-040	3
*	Nipple- 15xClose, Back Iron	8655-073-041	1
*	Union- 1/2, Black Iron	8615-104-035	1
*	Valve-Gas Shutoff, (Optional)	9379-196-001	1
13	Duct Assy, Recirculation	9973-033-001	1

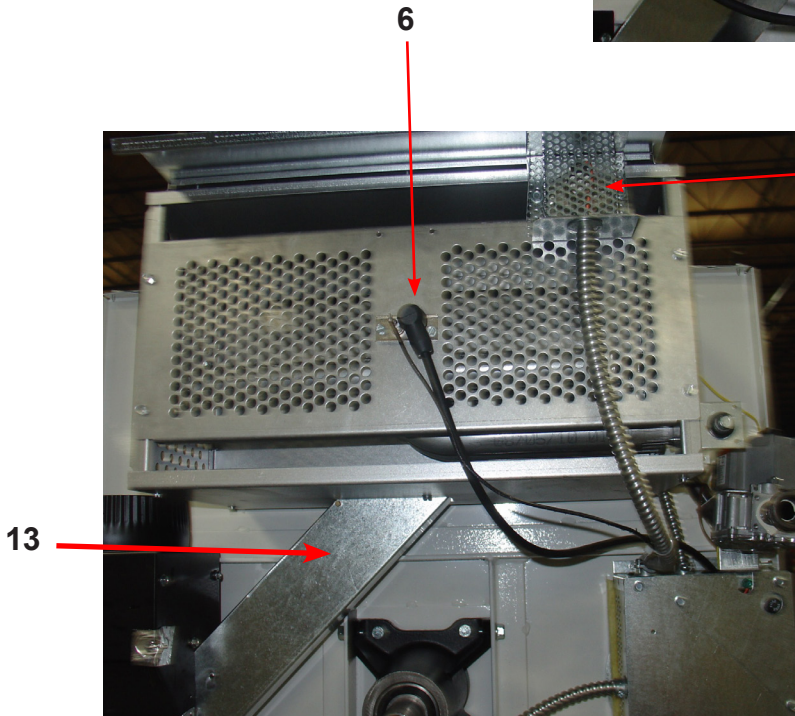
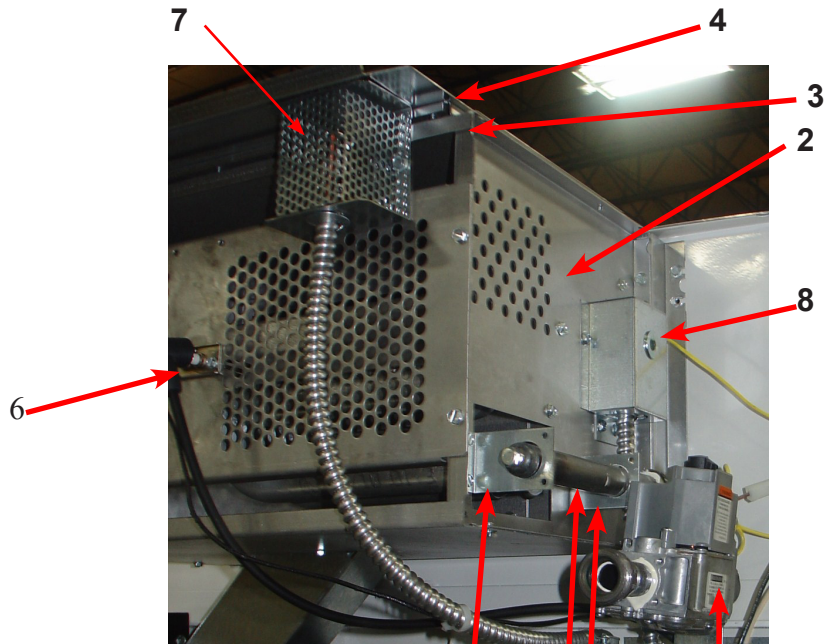
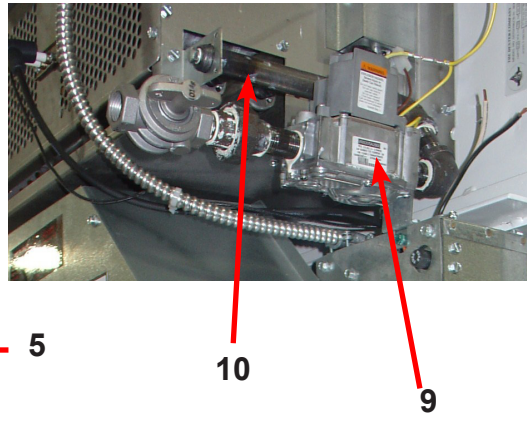
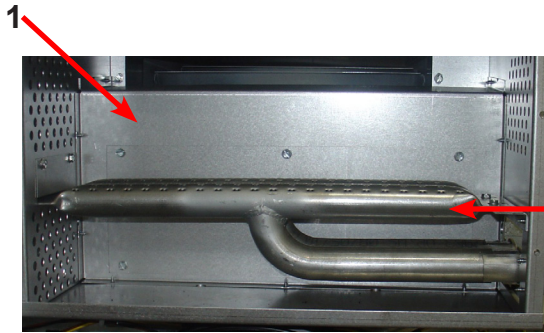

Dryer Burner Housing Group After Serial #232998

Key	Description	Part Number	Qty
*	Housing Assembly, Burner	9803-199-001	1
1	Panel-Burner Housing Front & Back	9454-831-001	1
*	Panel-Burner Housing, Side Left	9454-789-001	1
2	Panel-Burner Housing, Side Right	9454-790-001	1
*	Baffle-Burner Housing	9049-080-001	1
*	Connector Assembly- Burner	9828-015-001	1
3	Panel-Burner Housing, Top	9454-791-001	1
4	Cover Burner Housing, Top	9074-307-001	1
*	Screw, 10Bx1/4	9545-008-001	4
*	Screw, 10ABx3/8	9545-008-006	23
*	Plate, Recirculation Cover	9452-729-001	1
*	Screw, 10Bx1/4	9545-008-001	6
*	Shield, Burner Inlet	9550-173-001	1
*	Screw, 10ABx3/8	9545-008-024	3
5	Burner, Main	9048-020-001	2
*	Panel- Burner Housing, Back	9454-816-001	1
*	Screw, 10Bx1/4	9545-008-001	4
6	Electrode-Ignition	9875-002-003	1
*	Screw, 8Bx1/4	9545-045-001	2
7	Thermostat-HI-Limit	9576-203-002	1
*	Bracket-Hi-Limit	9029-192-001	1
*	Spacer-Hi-Limit	9538-142-001	2
*	Screw, 8Bx3/4	9545-045-007	2
*	Wire Assy-BRN, 31"	8220-001-415	1
*	Wire Assy-ORG, 31"	8220-095-018	1
*	Thermostat-Over Temp, Manual Reset	9576-207-008	1
*	Screw, 10ABx3/8	9545-008-006	2
*	Bushing, Over Temp	2114-008-000	2
8	Cover Assembly, OverTemp Thermostat	9825-057-002	1
*	Screw, 10ABx3/8	9545-008-006	2
9	Control Assy, Gas Valve	9857-134-001	1
10	Manifold Assy	9381-012-001	1
*	Orifice-Natural, #32	9425-069-009	2
*	Orifice-LP, #50	9425-069-008	2
11	Bracket-Manifold, Gas	9029-257-001	1
12	Bracket-Manifold, Gas	9029-258-001	1
*	Screws,	9545-008-006	4
13	Duct Assy, Recirculation	9973-033-001	1
13	Valve-Gas Shutoff, (Optional)	9379-196-001	1
14	Plug, Manifold		1

1

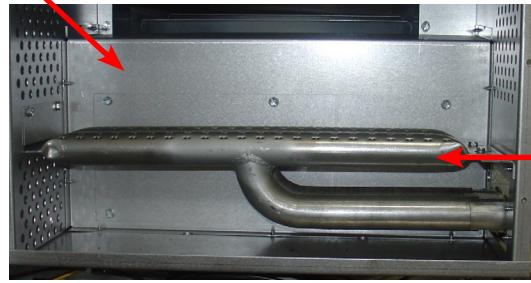

6

2

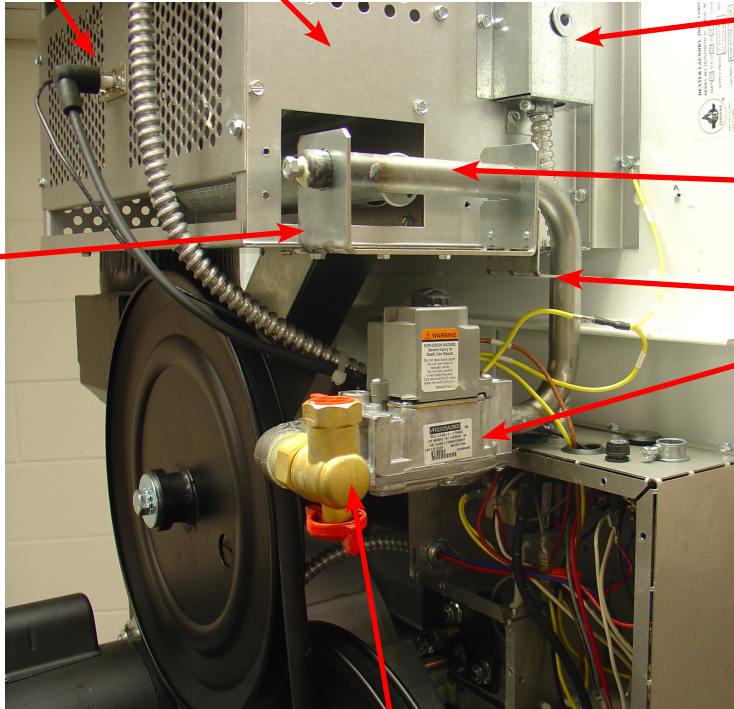

11

8

10

12

9

4

14

3

6

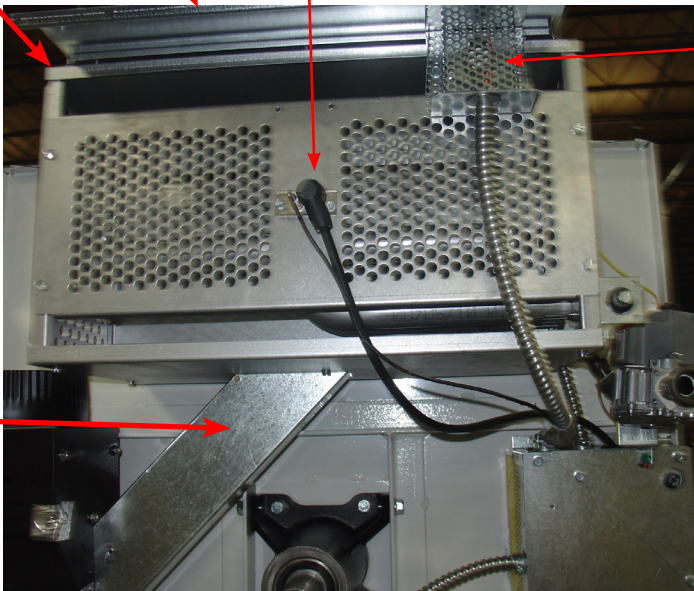

7

13

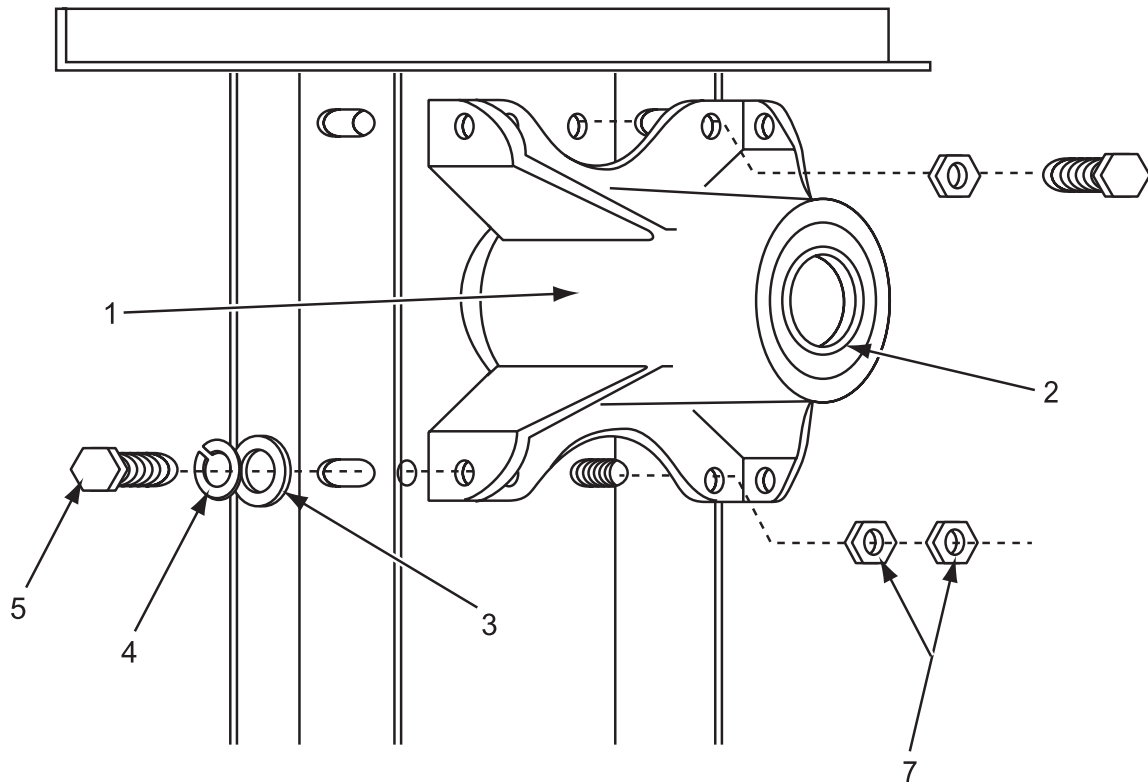

Bearing Housing Assembly

Key	Description	Part Number	Qty
1	Housing, Bearing	9241-161-002	1
2	Bearing, Ball (Front & Rear)	9036-130-001	2
3	Washer, Flat 3/8	8641-581-009	4
4	Lock Washer Spring, 3/8	8641-582-003	4
5	Screw, 3/8-24x3/4	9545-049-002	4
6	Nut, 3/8-24	8640-415-002	2
7	Screw, 3/8-24x1	9545-049-001	2
8	Nut, 5/16-24	8640-400-002	4
*	Spacer, Bearing	9538-139-002	1
*	Shim, Tumbler	9552-013-003	4
*	Bearing Housing Complete Assy (Includes bearings & Spacer)	9803-160-003	1

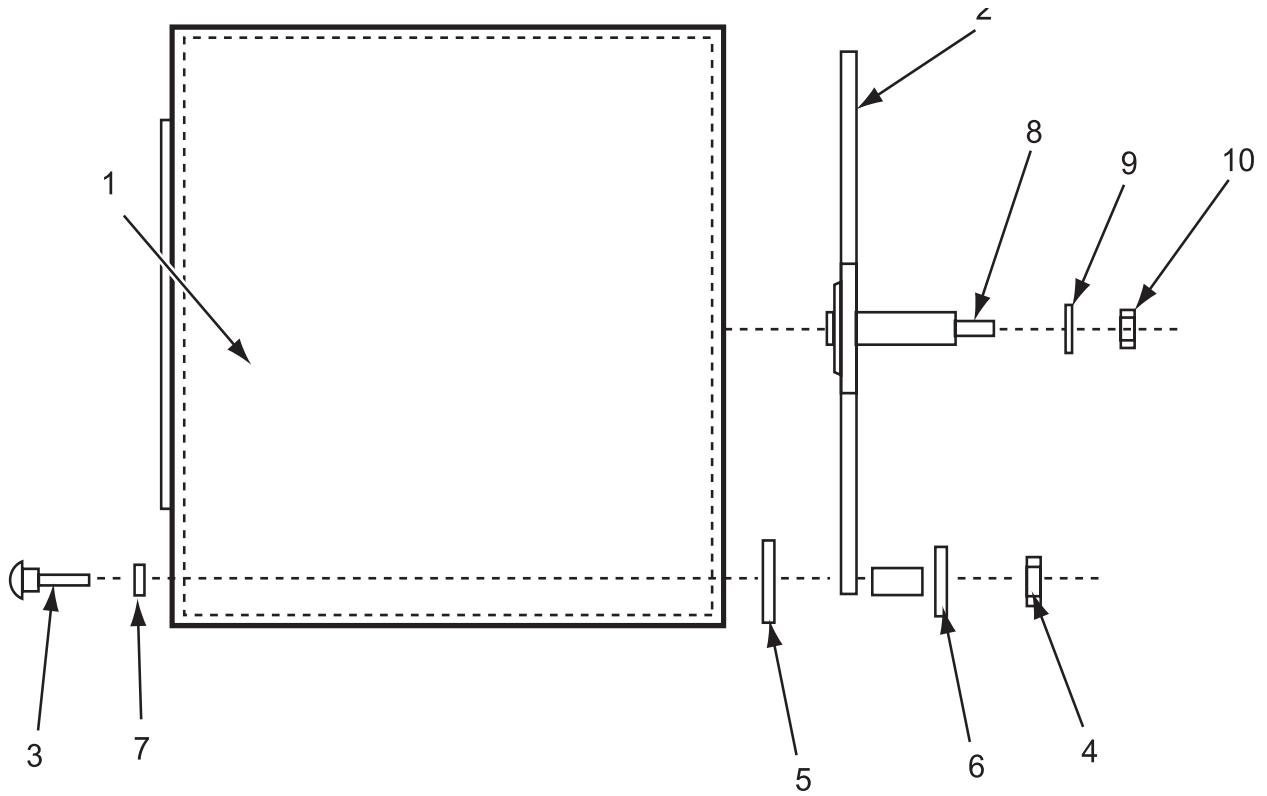

Spyder Trunion & Cylinder

Key	Description	Part Number	Qty
*	Tumbler Assy Complete W/Spider (GALV)	9848-127-001	1
1	Tumbler Assy (Galvanized)	9848-126-001	1
1	Tumbler Assy Complete W/Spider (SS)	9848-127-002	1
1	Tumbler Assy (Stainless)	9848-126-002	1
2	Spider Assy	9568-011-001	1
3	Rod, Tumbler	9497-019-003	3
4	Nut, Wiz Lock	8640-415-004	3
6	Shim	9552-013-000	AR
7	Washer, Special	8641-554-001	3
8	Key- Woodruff	9306-006-000	1
9	LockWasher - IntTooth, 1"	8641-582-015	1
10	Washer -Flat	8641-581-035	1
11	Nut-Hex, 1" -14	8640-222-000	1

Dryer Rear View-Bearing Housing 30Lb

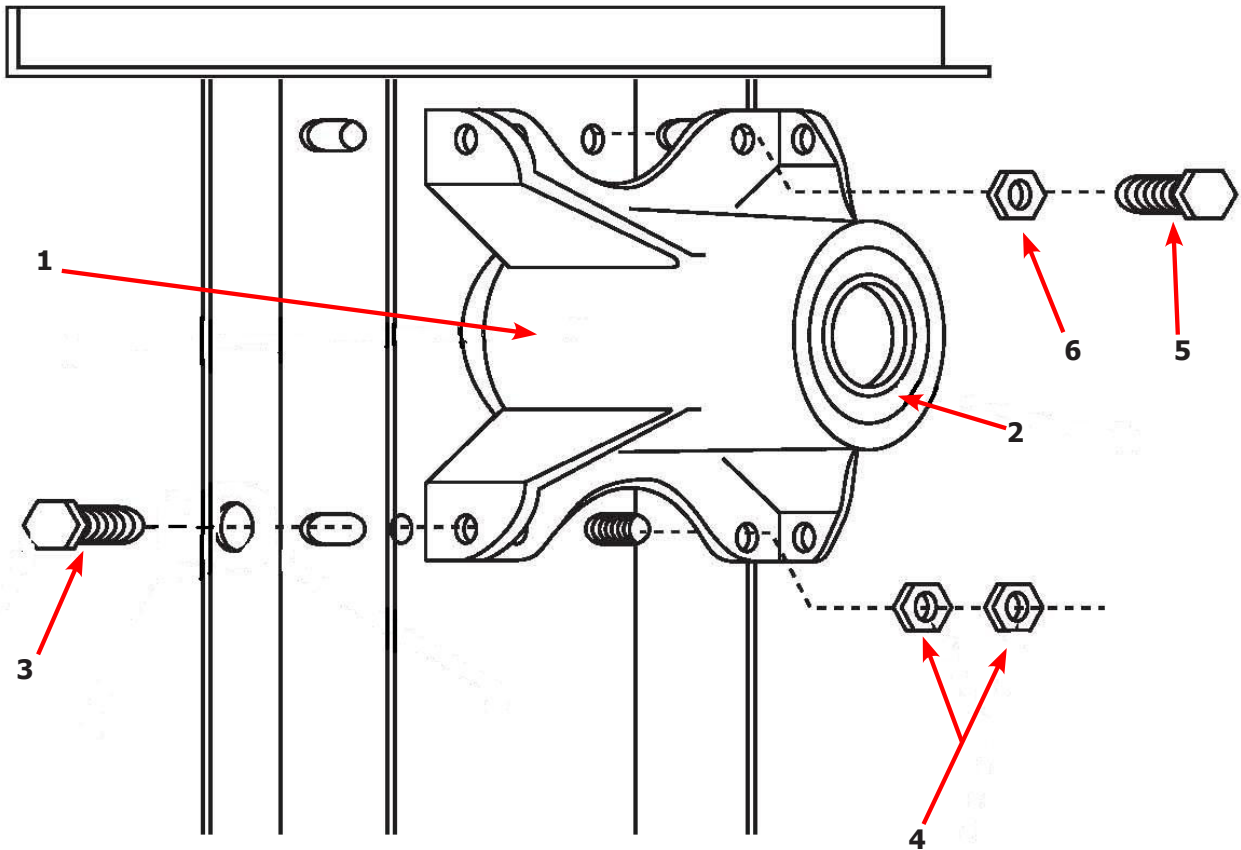

Key	Description	T-30	QTY
*	Bearing Housing Complete Assy (Includes bearings & Spacer)	9803-160-003	1
1	Housing, Bearing	9241-161-002	1
*	Bearing, Ball, Front	9036-130-001	1
*	Spacer, Bearing	9538-139-002	1
2	Bearing, Ball, Rear	9036-130-001	1
3	Screw-Wizlock, 3/8-24x3/4	9545-049-002	4
4	Nut, 5/16-18	8640-400-002	4
5	Screw, 3/8-24x1	9545-049-001	2
6	Nut, 3/8-24	8640-415-002	2
*	Shim, Tumbler	9538-139-002	AR

Dryer Tumbler Group 30Lb

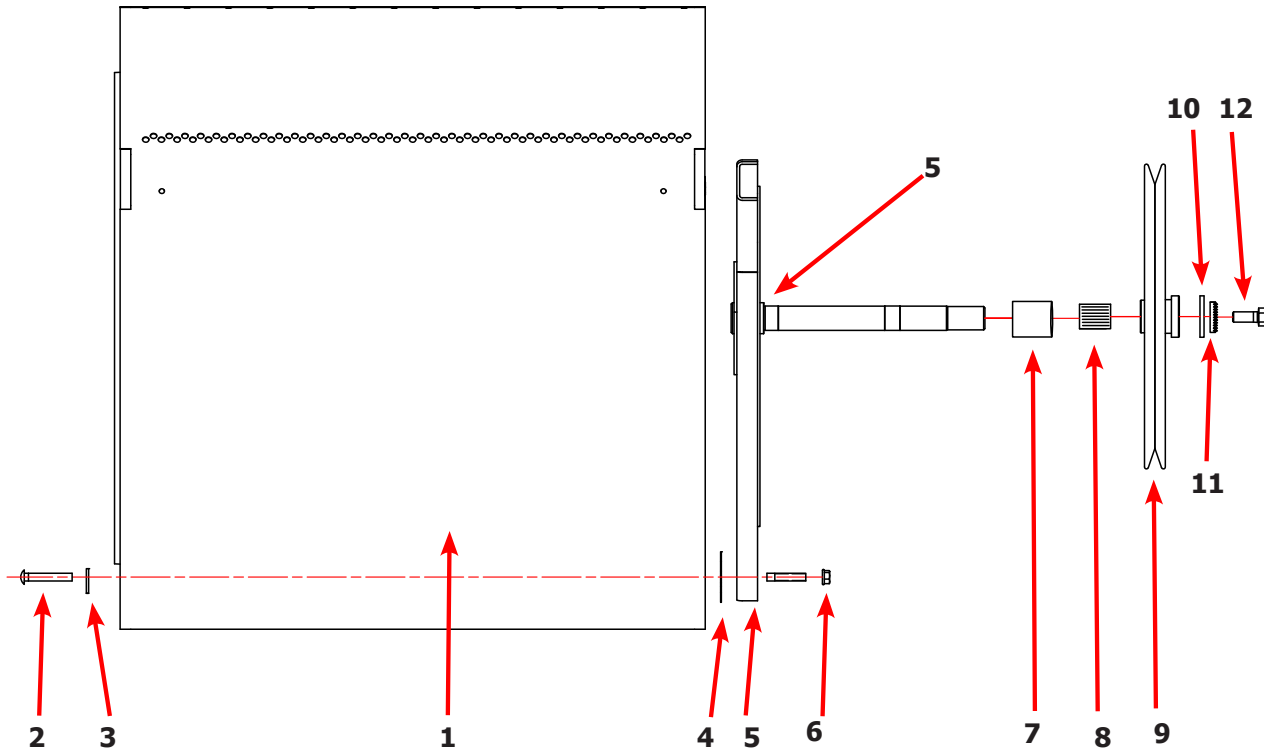

Key	Description	T-30	QTY
*	Tumbler Assy Complete W/Spider (GALV)	9848-142-001	1
1	Tumbler Assy (Galvanized)	9848-126-001	1
1	Tumbler Assy Complete W/Spider (SS & Galv front)	9848-142-002	1
1	Tumbler Assy (Stainless Galvanized front)	9848-126-002	1
2	Rod, Tumbler	9497-019-003	4
3	Washer, Special	8641-554-001	4
4	Shim	9552-013-003	AR
5	Spider Assy	9568-015-001	1
6	Nut, Wiz Lock	8640-415-004	3
7	Spacer-Shaft	9538-164-001	1
8	Tolerance Ring	9487-234-005	1
9	Pulley, Driven	9908-049-002	1
10	Washer -Flat	8641-581-026	1
11	LockWasher - IntTooth, 1"	8641-582-016	1
12	Screw, 1/2-13x1 1/4	9545-017-009	1

Dryer Rear View

Key	Description	Part Number	Qty
1	Motor, Drive	9376-309-001	1
2	Plate, Motor Mounting	9452-766-001	1
*	Screw-Hex, 3/8-16x3/4	9545-029-008	4
*	Screw, Motor to Plate to Housing Back	9545-018-019	5
*	Lock Washer	8641-582-007	5
*	Spacer	9538-163-006	5
*	Flat Washer	8641-581-017	15
*	Rubber Grommet	9209-086-002	5
*	Grommet Spacers, Metal	9538-166-006	5
*	Pulley, Motor	9453-157-001	1
*	Screw, Set Motor Pulley	9545-028-013	2
3	Back Assy, Blower Housing	9962-015-002	1
*	Impeller, W/Set Screws	9278-039-001	2
4	Belt, Drive Motor	9040-073-009	1
5	Belt, Driven-Tumbler	9040-077-001	1
6	Pulley, Driven	9908-040-001	1
*	Key- Woodruff	9306-006-000	1
*	6" Slide Open Clean Out Duct (Optional)	9973-035-001	1

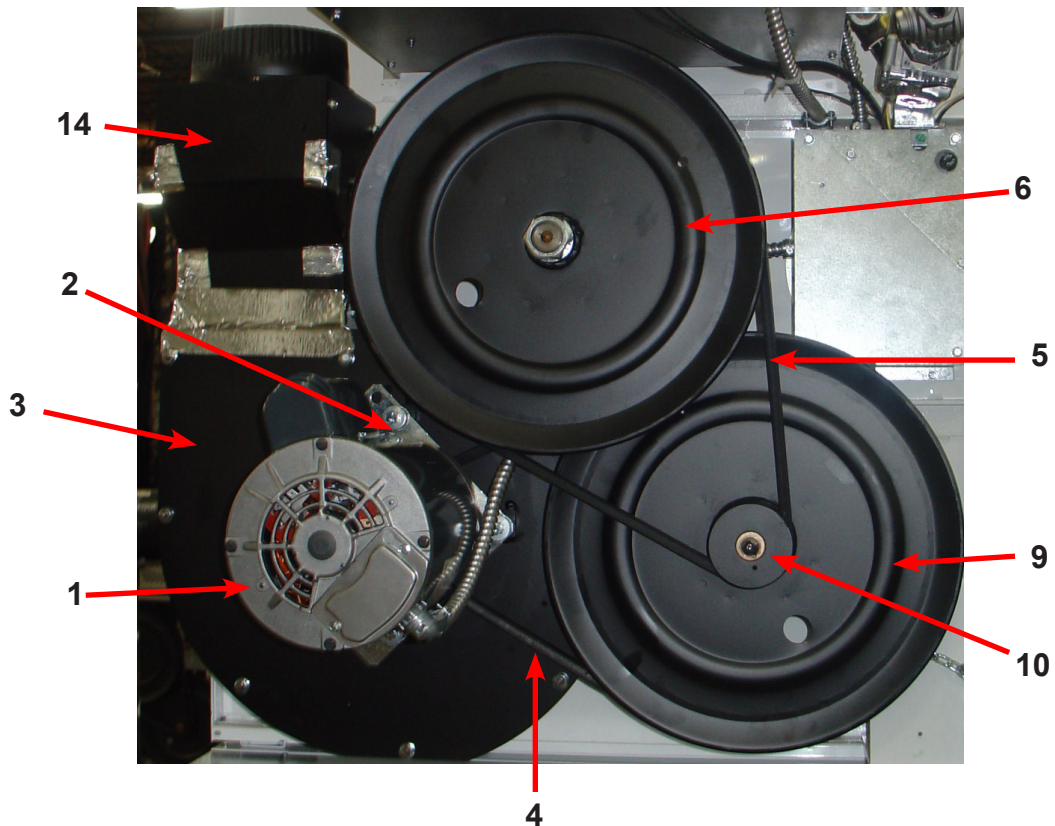

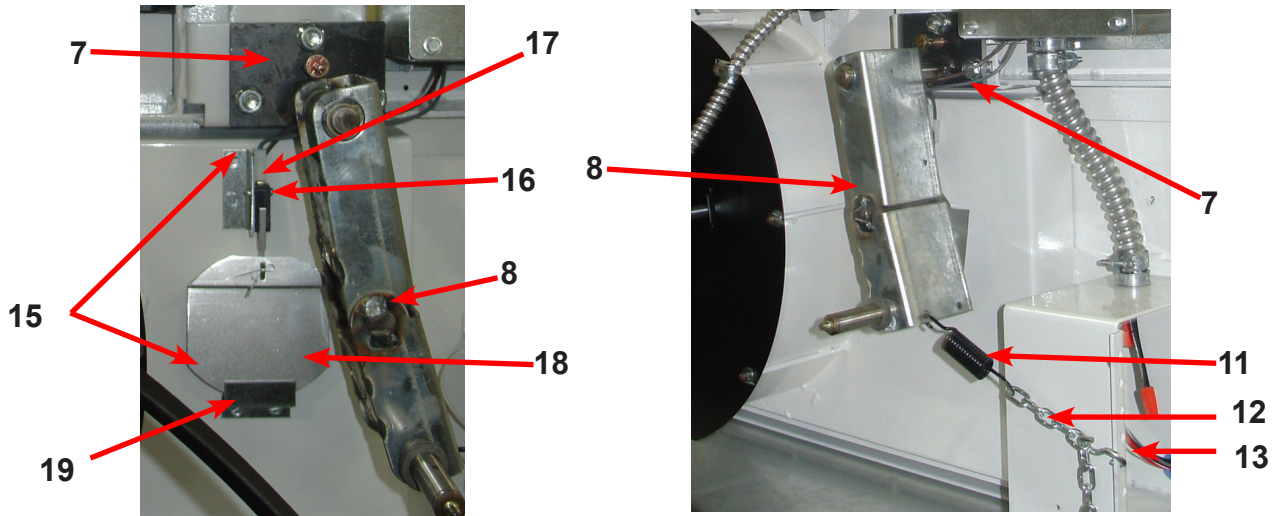

Key	Description	Part Number	Qty
7	Support Assy, Intermediate Pulley	9991-053-001	1
*	Bolt, Rd Hd 3/8-16x1 1/4	9545-029-010	3
*	Bolt 3/8-16x 1 1/2	9545-029-003	1
*	Nut	8640-415-004	3
*	Washer Flat	8641-581-035	4
8	Arm Assy-Tension, Complete	9861-022-001	1
*	Washer Flat	8641-581-035	3
*	Ring-Retaining	9487-200-003	3
9	Pulley Assy, Intermediate	9908-039-004	1
10	Bushing, Bronze	9036-145-002	2
*	Spacer, Shaft	9538-164-001	1
*	LockWasher - IntTooth, 1"	8641-582-015	1
*	Washer -Flat	8641-581-035	1
*	Nut-Hex, 1" -14	8640-222-000	1
11	Spring, Tension	9534-319-002	1
12	Chain, Tension	9099-012-002	1
13	Hook, Tension	9248-022-002	1
14	Housing-Assy, Damper	9803-184-002	1
*	Damper	9125-003-001	1
*	Pin, Hinge Damper	9451-146-004	2
*	Nut, Spring	8520-141-000	4
15	Switch Assembly, Air Flow	9801-060-001	1
16	Switch, Air Flow	9539-461-009	1
17	Bracket, Switch-Air Flow	9029-044-001	1
18	Acuator, Switch	9008-007-001	1
*	Pin, Cotter	9451-169-002	1
*	Screw	9545-020-001	2
*	Nut, Special Twin	8640-401-001	1
*	Shield, Switch	9550-169-003	1
19	Bracket, Actuator Stop	9029-046-001	1
*	Screw	9545-008-024	4

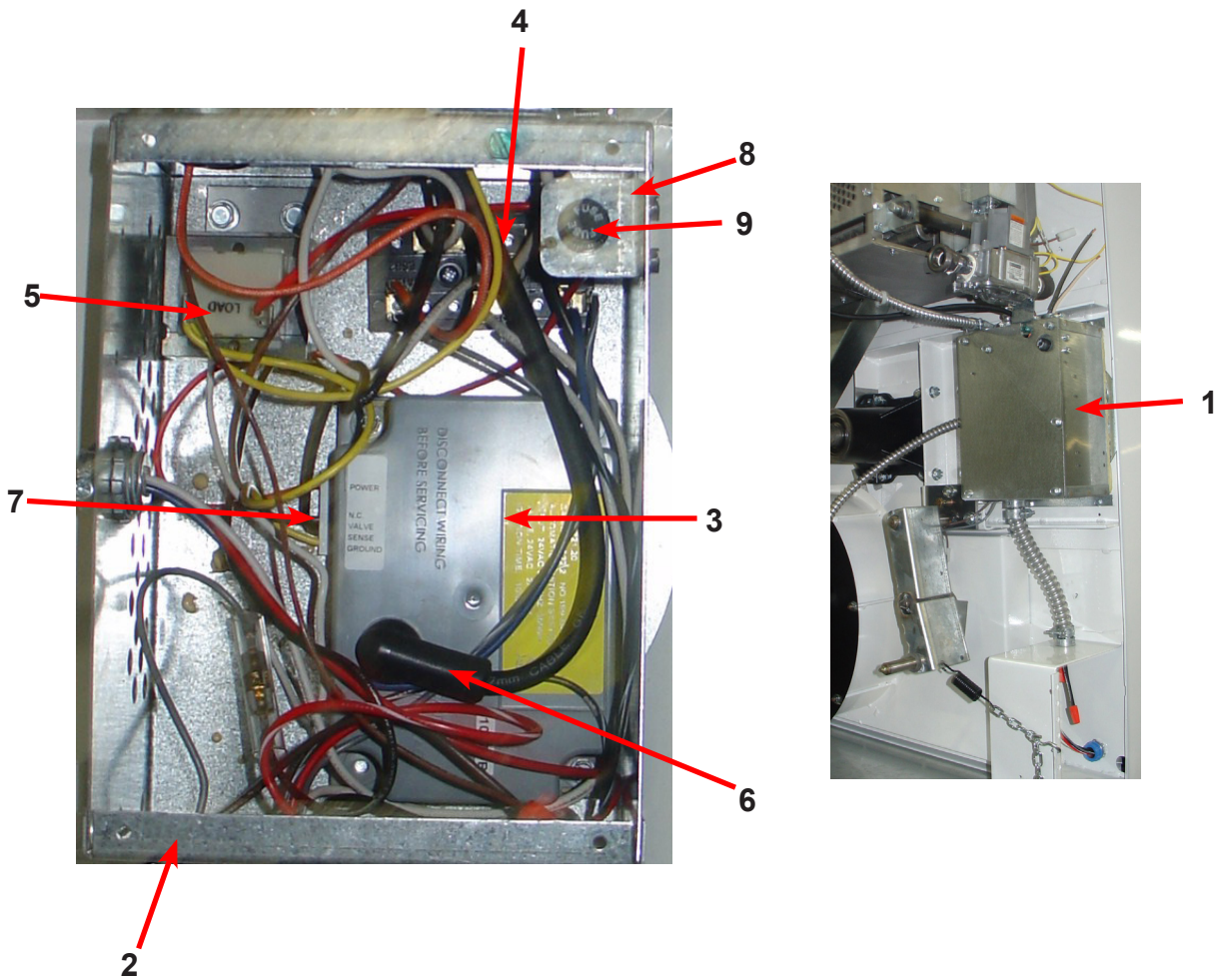

Electrical Box / Ignition Control Before S/N 232998

Key	Description	Part Number	Qty
1	Control Assembly-Ignition, Complete (2-9 included)	9857-128-001	1
2	Box- Ignition Control	9807-079-001	1
3	Control, Ignition	9857-116-003	1
4	Terminal Block-Power	9897-026-001	1
5	Transformer 120/24VAC	8711-011-001	1
6	Wire Assy- Hi Voltage	9631-403-002	1
7	Harness- Low Voltage	9627-678-001	1
*	Wire Assy-Red, 9"	8220-001-225	1
8	Bracket Fuse Holder	9029-048-001	1
9	Fuse Holder	9200-001-002	1
*	Fuse, 1.5 Amp	8636-018-001	1
*	Insulation, Electrical Box (back)	9277-041-013	1

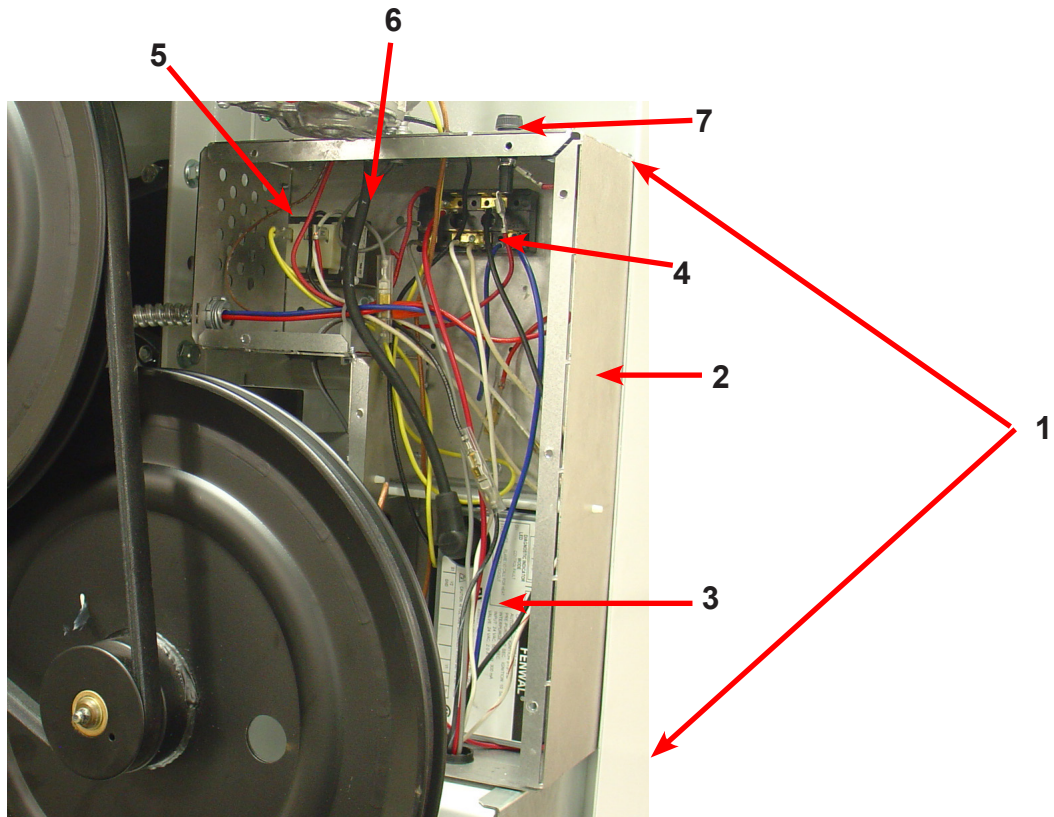

Electrical Box / Ignition Control After S/N 232998

Key	Description	Part Number	Qty
1	Control Assembly-Ignition, Complete (2-9 included)	9857-128-021	1
2	Box- Ignition Control	9807-109-001	1
3	Control, Ignition	9857-182-001	1
4	Terminal Block-Power	9897-026-003	1
5	Transformer 120/24VAC	8711-011-001	1
*	Wire Assy-Red, 9"	8220-001-225	1
6	Wire Assy- Hi Voltage	9631-403-009	1
7	Fuse Holder	9200-001-002	1
*	Fuse, 1.5 Amp	8636-018-001	1
*	Insulation, Electrical Box (back)	9277-041-013	1

Electrical Box / Ignition Control After S/N 232998

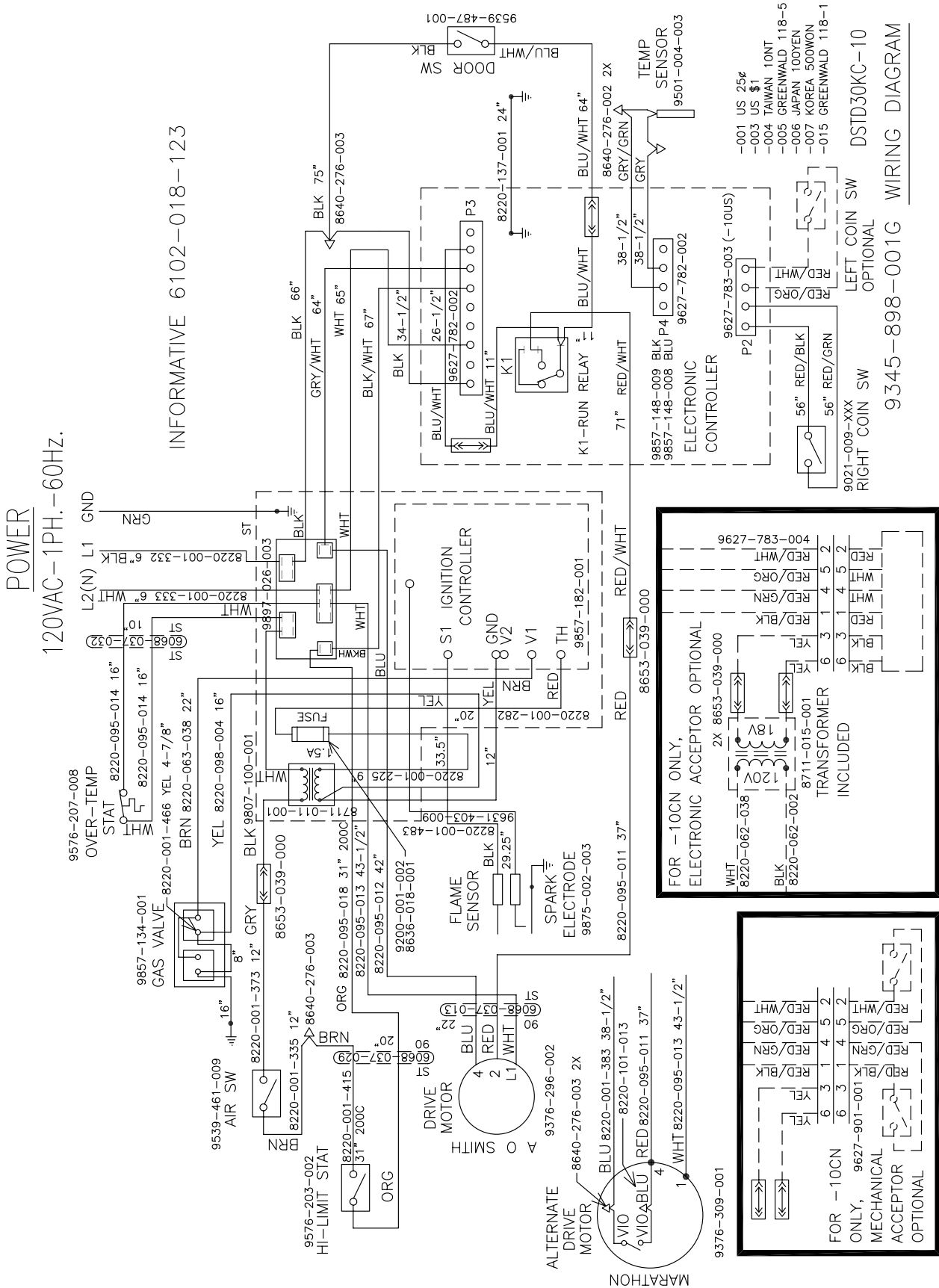

Coin Handling Group

Key	Description	Part Number	Qty
	Harness, Main	9627-782-001	1
*	Harness, Coin Switch	9627-783-001	1
*	Harness, Low Voltage	9627-678-001	1
*	Transformer, 120V/24V	8711-011-001	1
*	Terminal Block	9897-026-001	1
*	Hi Voltage Lead	9631-403-002	1
*	Diagram, Wiring	9345-898-001	1
*	Schematic, Wiring	9345-897-001	1
9	Acceptor, Micro Switch	9021-009-001	1
9	Switch, Coin	9539-466-005	1
*	Acceptor Chute Assy w/o penny rejector	9119-025-002	1
8	(optional) Acceptor Chute Assy w/ penny rejector	9119-025-001	1
*	Retainer, Coin Acceptor	9486-145-001	1
*	Screw, Torx	9545-053-002	4
*	Screw-Height Bar, 3mm	9545-039-002	2

Coin Handling Group

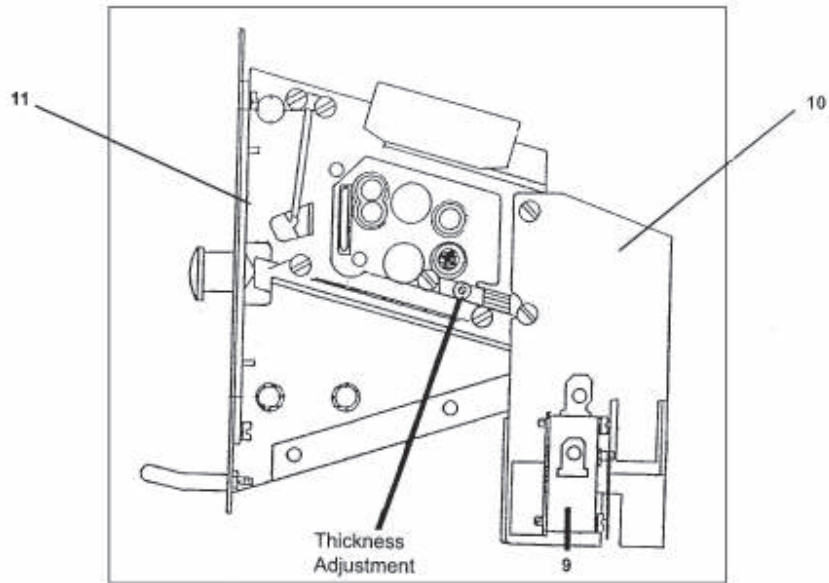

#8 COIN ACCEPTOR - right side

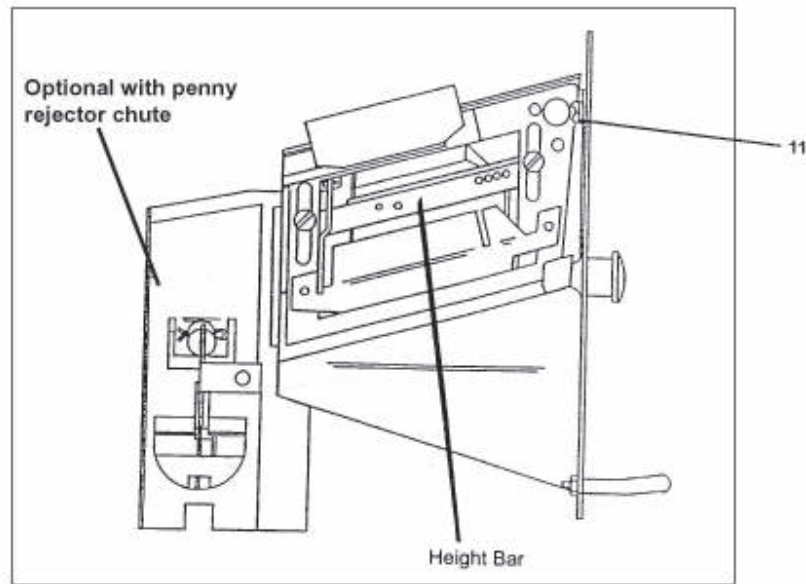

#8 COIN ACCEPTOR - left side

Dryer EasyCard Group

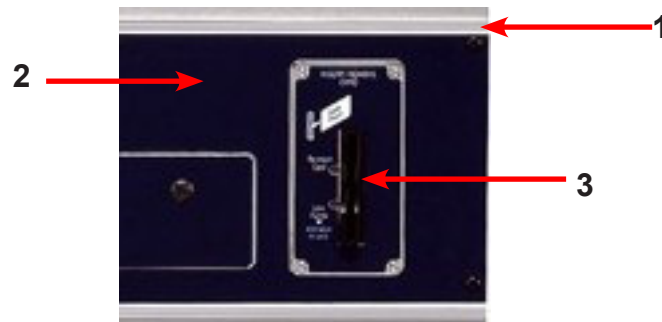

Key	Description	Part Number	Qty
	Panel-Front, Stack Washer Dryer, Dryer	9454-509-001	1
	Escutchen-Upper	9141-152-001	1
	Overlay-Escutcheon	9435-018-002	1
	Harness-Reader	9627-731-001	1
	Reader, Simple (Reader only no Face Plate)	9797-006-003	1
	Cable Cat5, 20' s/s	9806-013-003	1
	Lable, EasyCard Instructions	8502-729-001	1
	Schematic	9506-148-001	1
	Diagram	9506-149-001	1

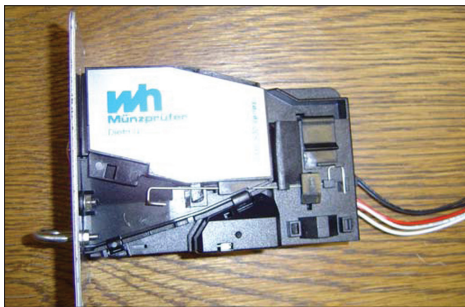

Key	Description	Part Number	Qty
	Acceptor-Electronic	9021-012-001	1
	Transformer, 120/24VAC	8711-015-001	1
	Harness, Door Coin Switch	9627-783-002	1
	Wire Jumper, BLK	8220-133-001	1
	Wire Jumper, WHT	8220-133-002	1
	Lable-Wiring, Electronic Acceptor	8502-730-001	1
	Connector, Inline, 1/4	8653-039-000	6
	Retainer Coin Acceptor, Electronic	9486-155-001	2

Section 6:

Electric Heated
Dryer:
Wiring Diagram
and Parts Data

Wiring Schematic for Electric Dryer -16FC

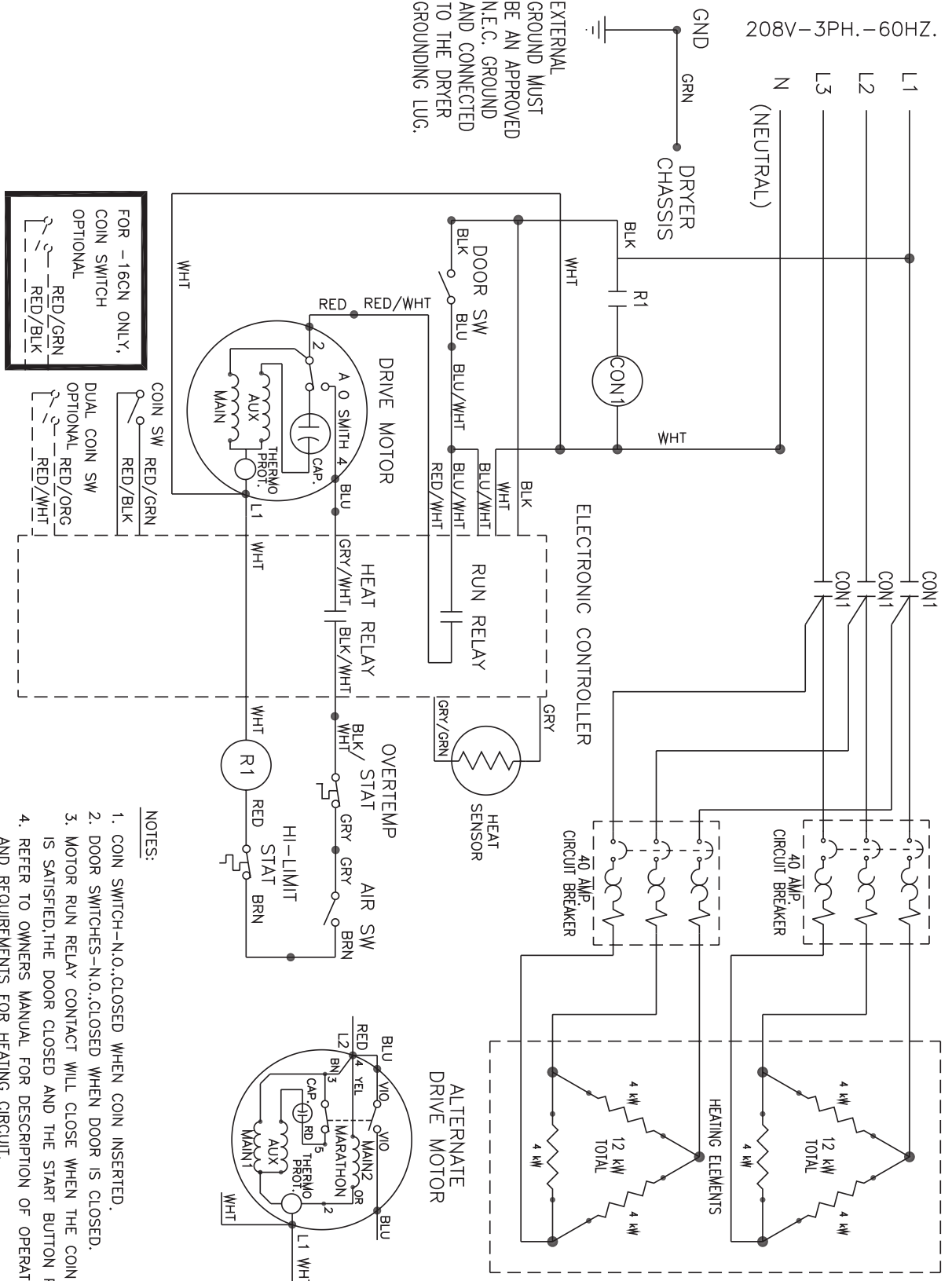

9345-993-001B

SCHEMATIC

D_T_30KC_16FC

- NOTES:**
1. COIN SWITCH-N.O.CLOSED WHEN COIN INSERTED.
 2. DOOR SWITCHES-N.O.CLOSED WHEN DOOR IS CLOSED.
 3. MOTOR RUN RELAY CONTACT WILL CLOSE WHEN THE COIN COUNT IS SATISFIED,THE DOOR CLOSED AND THE START BUTTON PRESSED.
 4. REFER TO OWNERS MANUAL FOR DESCRIPTION OF OPERATION AND REQUIREMENTS FOR HEATING CIRCUIT.

Wiring Diagram for Electric Dryer -16FC

9345-994-001B

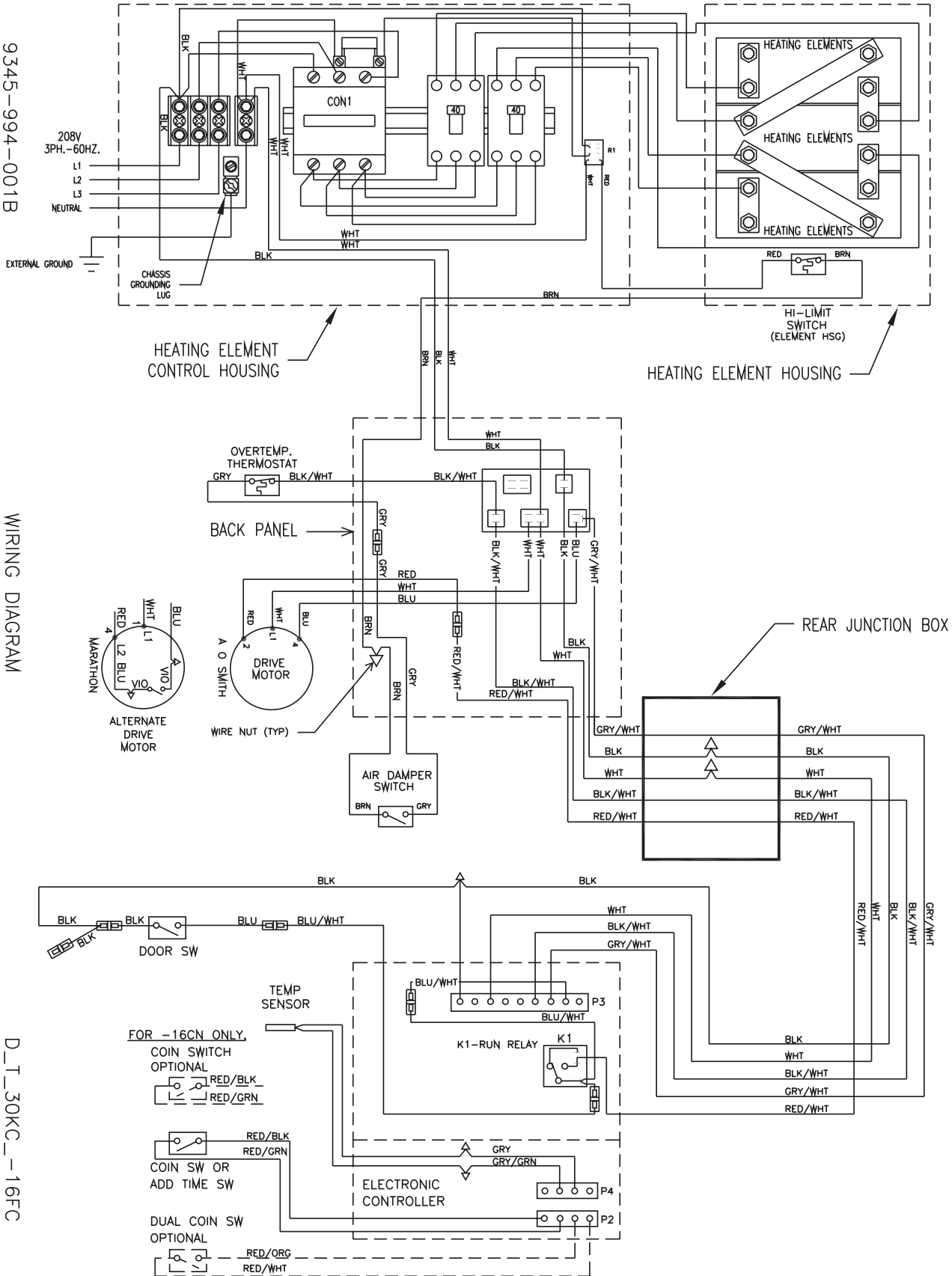

WIRING DIAGRAM

D_T_30KC_-16FC

Wiring Schematic for Electric Dryer -60FA

9506-214-001B

SCHEMATIC

D_T_30KC_60FA

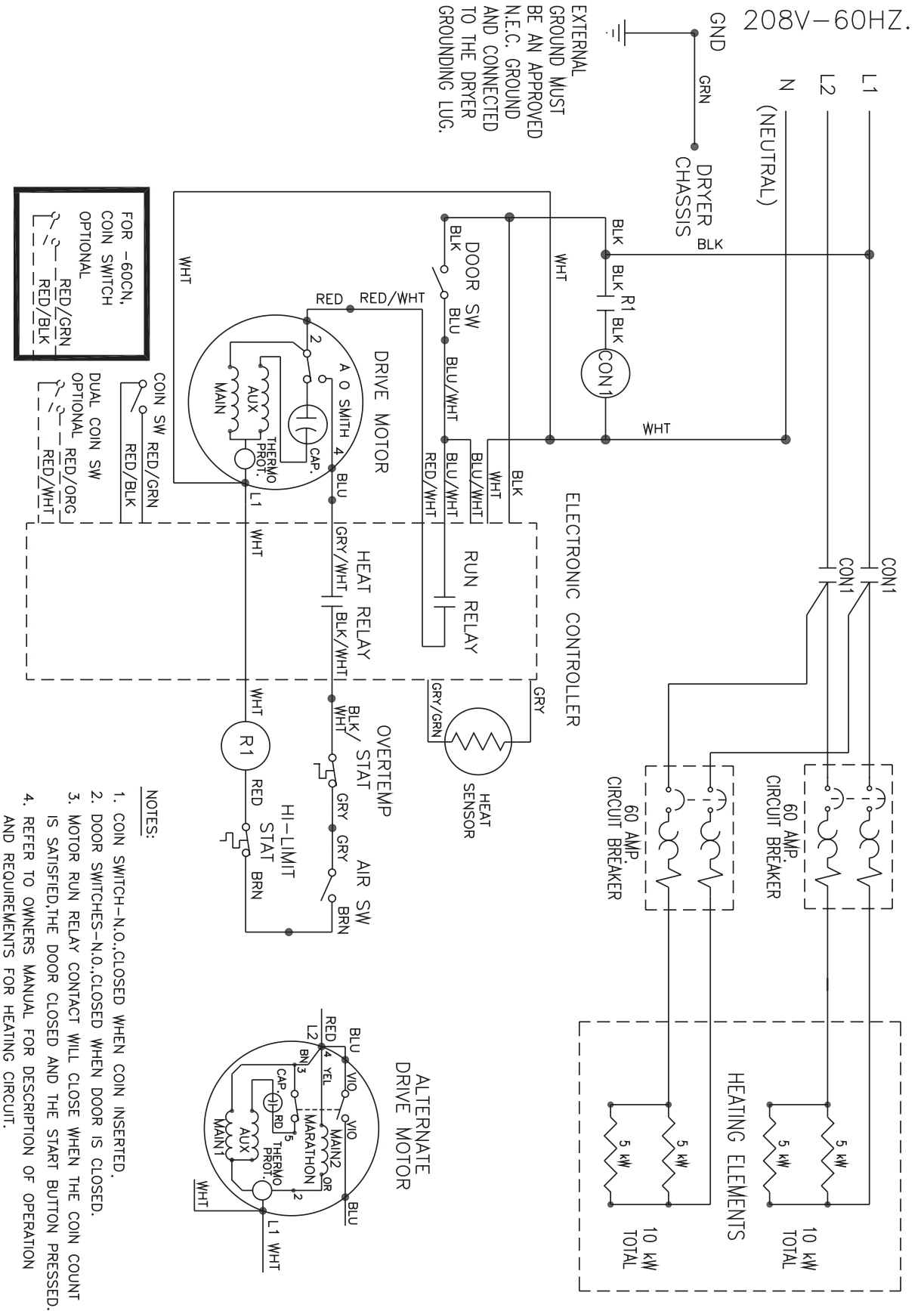

Wiring Diagram for Electric Dryer -60FA

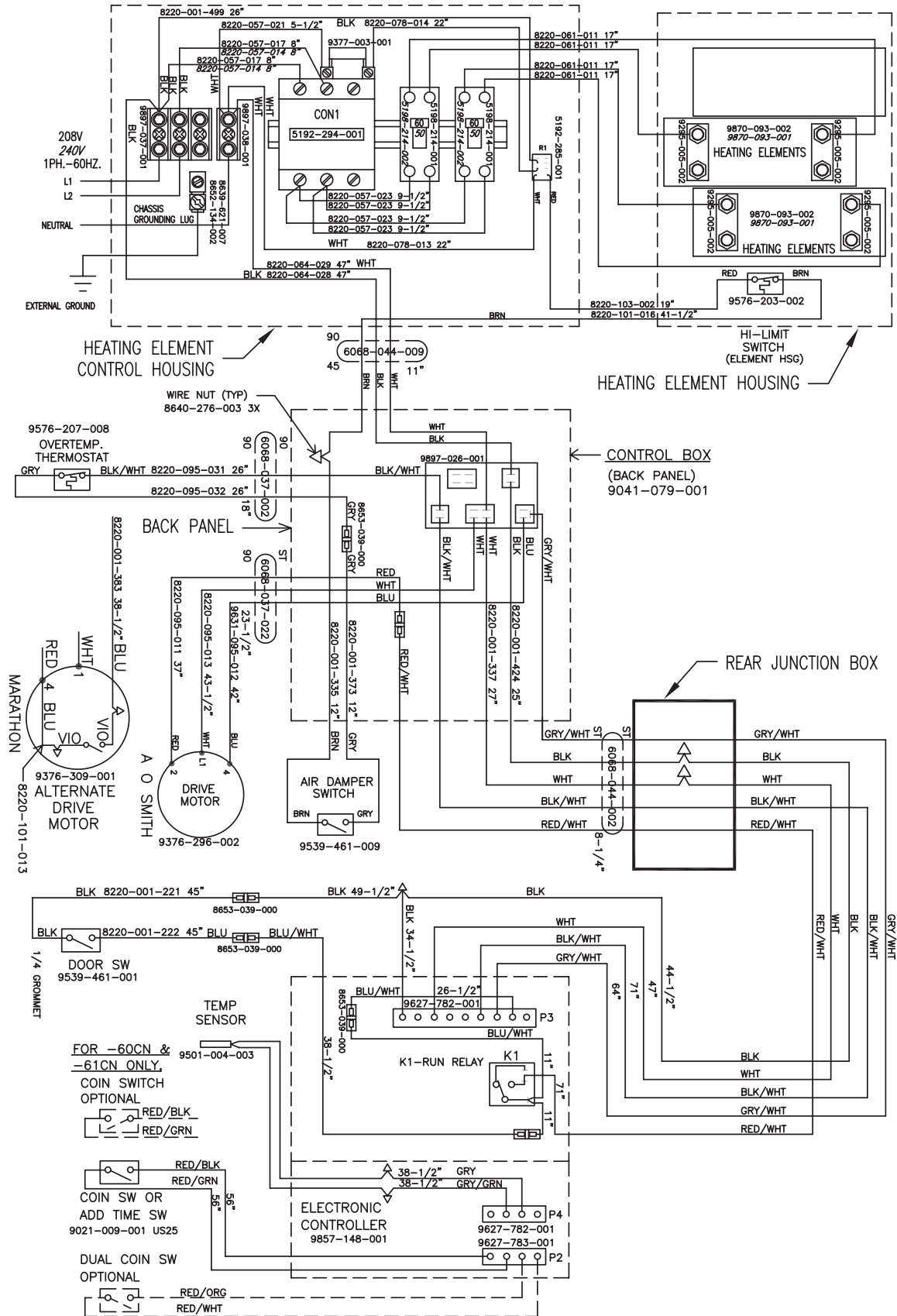

9506-215-001B
9506-XXX-001

INFORMATIVE 9506-018-102
WIRING DIAGRAM

DSTD30KC_-60FA
DSTD30KC_-61FB

Wiring Schematic for Electric Dryer -62FL

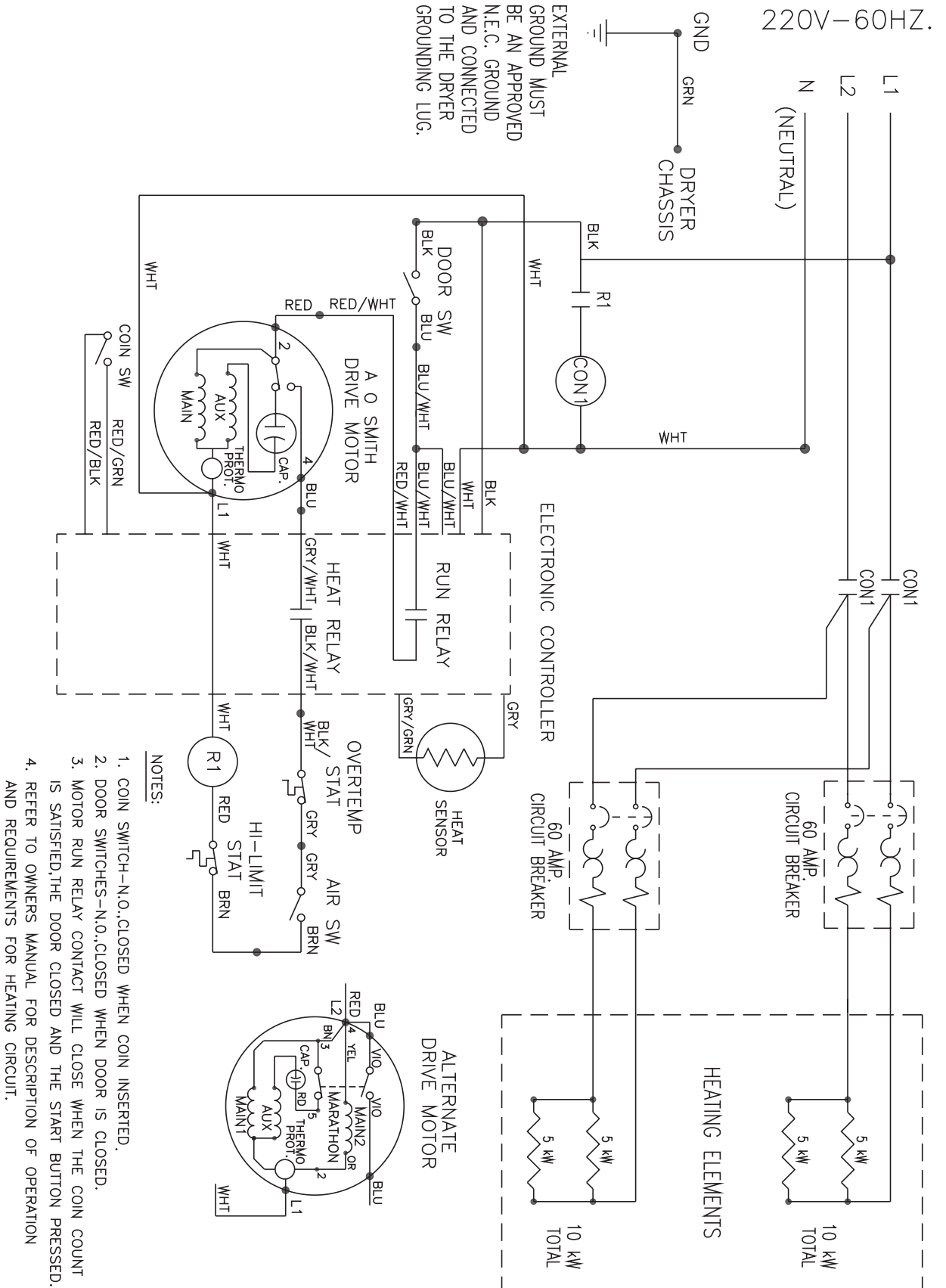

9345-987-002A

SCHEMATIC

D_T_30KC_62FL

Wiring Diagram for Electric Dryer -62FL

9345-988-002A

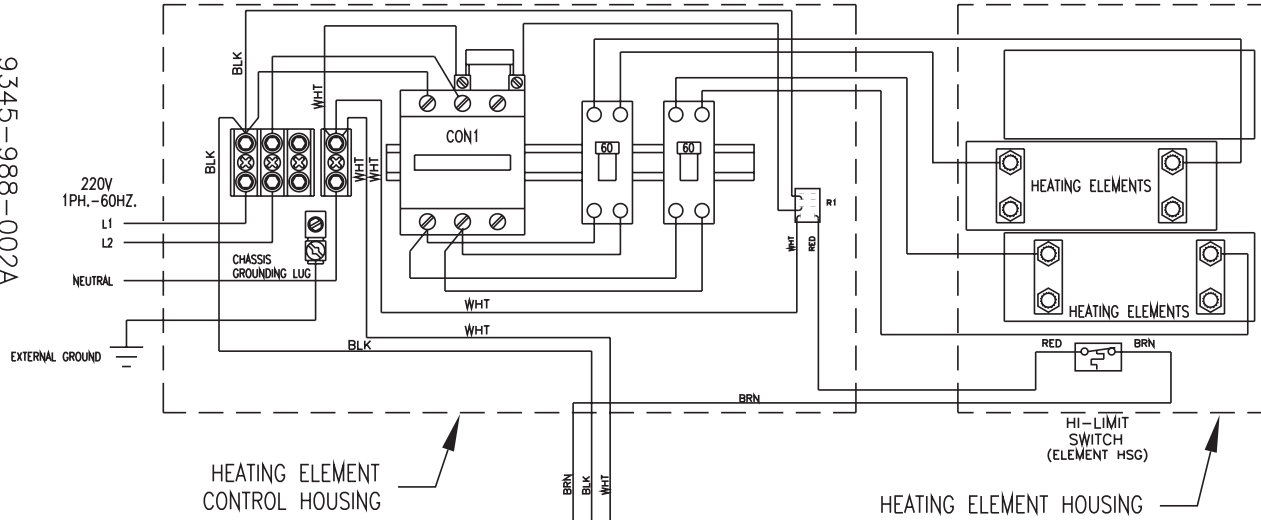

WIRING DIAGRAM

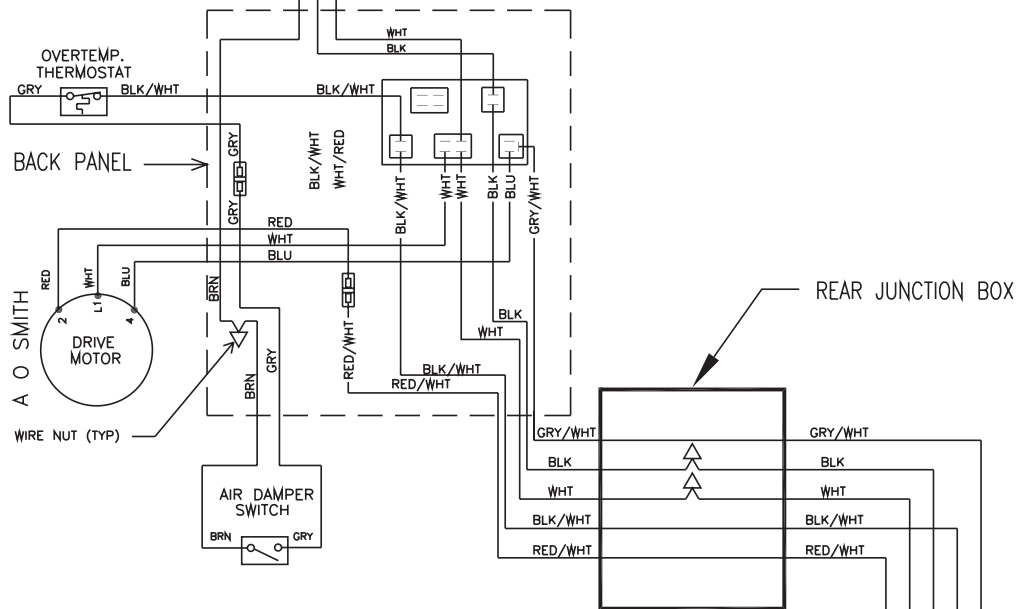
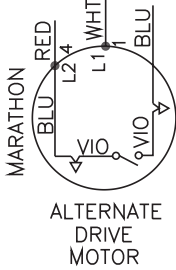

D_T_30KC_62FL

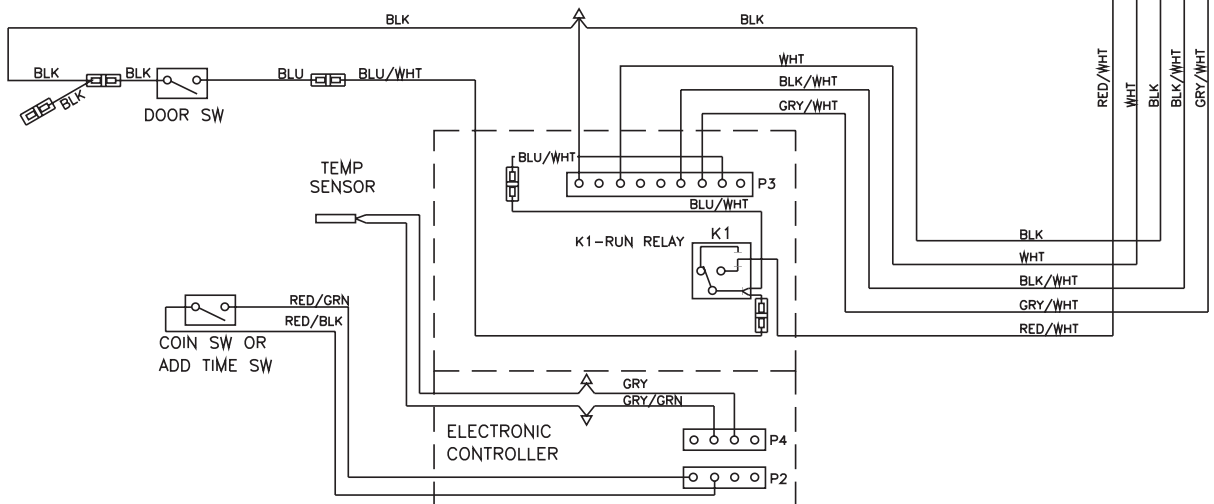

Wiring Schematic for Electric Dryer -66FW

9506-208-001A

SCHEMATIC

DST_30KC_66FW

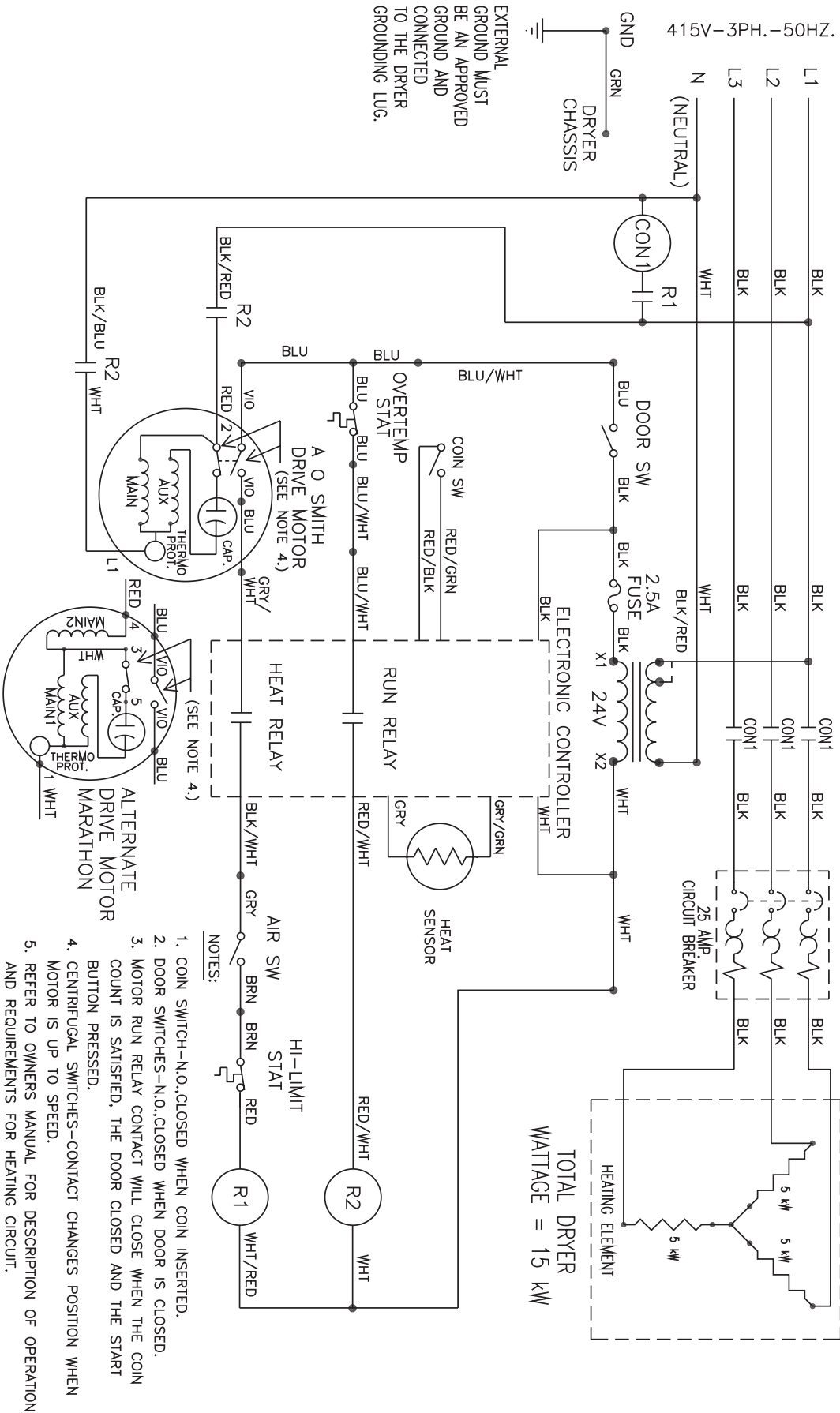

Wiring Diagram for Electric Dryer -66FW

9506-209-001A

WIRING DIAGRAM

DST_30KC_--66FW

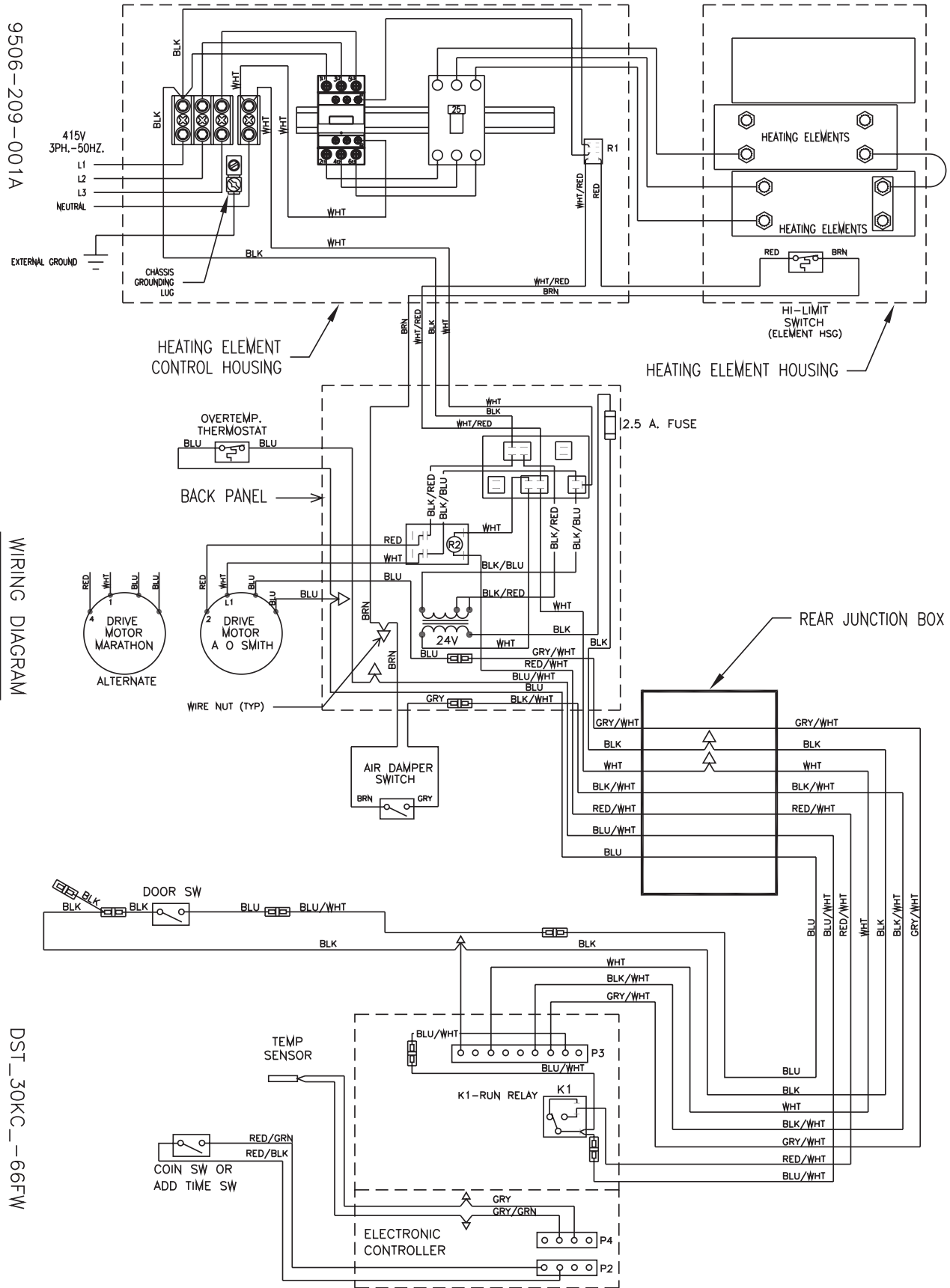

SWD Dryer Electric Heated DSTD30KC_-16FC

Key	Description	Part Number	Qty
*	COVER-HOUSING,CONTROL	9074-292-001	1
*	FILLER-COVER,TERMINAL	9185-007-001	1
*	VARISTOR-COILSUPPRESSOR	9377-003-001	1
*	CAP-ACTUATOR	0935-133-001	1
*	RAIL-DIN,35X15MM	9488-011-002	1
*	SIDE-HOUSING,CONTROL(RH)	9551-030-001	1
*	SIDE-HOUSING,CONTROL(LH)	9551-031-001	1
*	SIDE-HOUSING,HEATER(RIGHTHAND)	9551-032-001	1
*	SIDE-HOUSING,HEATER(LEFTHAND)	9551-033-001	1
*	WRAPPER-HOUSING,CONTROL	9636-154-001	1
*	WRAPPER-HOUSING,HEATER	9636-155-001	1
1	BLOCK-POWER,3POLE	9897-037-001	1
1	BLOCK-POWER,1POLE	9897-038-001	1
*	LABEL-WARNING,HIGHVOLTAGE	8502-614-005	1
*	LABEL-WARNING	8502-639-001	1
*	LABEL-WARN,FIREHAZARD(FRENCH)	8502-702-001	1
*	LABEL-EXHAUSTWARNING	8502-708-001	2
*	LABEL-WARNINGFOR208V	8502-711-001	1
*	BOOKLET-OWNERS,SWD	8514-046-002	1
3	WIRINGLABEL-SCHEMATIC	9345-993-001	1
3	WIRINGLABEL-SCHEMATIC	9345-993-002	1
3	WIRINGLABEL-DIAGRAM	9345-994-001	1
3	WIRINGLABEL-DIAGRAM	9345-994-002	1
*	BRACKET-THERMOSTATMOUNTING	9029-136-001	1
*	BOTTOM-HOUSING,HEATER	9058-026-001	1
*	COVER-PLATE,HEATER	9074-293-001	1
*	COVER-TERMINAL,HEATER	9074-294-001	1
*	DEFLECTOR-BOTTOM,HOUSING	9114-044-001	1
*	DEFLECTOR-WRAPPER,HOUSING	9114-045-001	1
*	JUMPER-FORMED	9295-004-002	2
*	JUMPER-STRAIGHT	9295-005-002	4
*	BAFFLEASSEMBLY-HOUSING,HEATER	9812-014-001	1
*	HEATER-ELECTRICELEMENT	9870-093-004	3

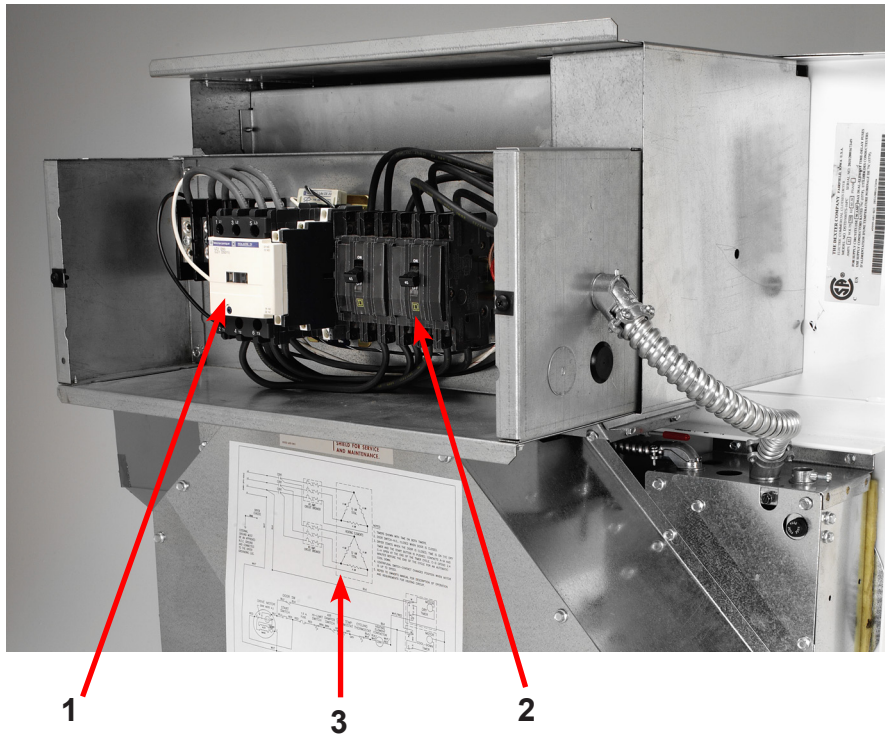

SWD Dryer Electric Heated DATD30KC_-62FL

Key	Description	Part Number	Qty
3	WIRINGLABEL-SCHEMATIC	9345-987-002	1
3	WIRINGLABEL-DIAGRAM	9345-988-002	1
	HEATER-ELECTRICELEMENT	9870-093-005	2
1	RELAY-125AMP(REISTIVE)CONTACT	5192-294-001	1
2	CIRCUITBREAKER-2POLE	5198-214-001	2

SWD DRYER Electric Heated DSTD30KC_-60FA

Key	Description	Part Number	Qty
1	RELAY-125AMP(REISTIVE)CONTACT	5192-294-001	1
2	CIRCUITBREAKER-2POLE	5198-214-001	2
3	WIRINGLABEL-SCHEMATIC	9506-214-002	1
3	WIRINGLABEL-DIAGRAM	9506-215-002	1
	HEATER-ELECTRICELEMENT	9870-093-002	2

SWD Dryer Electric Heated DSTD30KC_-66FW

Key	Description	Part Number	Qty
1	RELAY	5192-285-004	1
1	RELAY	5192-288-001	1
	FUSE-2.5A	8636-018-004	1
	BRACKET-FUSEHOLDER	9029-048-001	1
	FUSE HOLDER ASSEMBLY	9200-001-002	1
	TRANSFORMER-CONTROL	8711-008-002	1
	HEATER-ELECTRICELEMENT	9870-093-001	2
	VARISTOR-COILSUPPRESSOR	9377-003-002	1
	JUMPER-STRAIGHT	9295-005-002	1
	MOTOR-DRY,MRTHON(30#STK),50HZ	9376-318-001	1
	CONTROLSASY-ELEC,STKW/D(W/IR)	9857-148-002	1
	PULLEY-DRIVE,MACHINED	9453-169-009	1
3	WIRINGLABEL-SCHEMATIC	9506-208-001	1
31	WIRINGLABEL-DIAGRAM	9506-209-001	1
	DRAWERASY-LINT,UP/LOW(AUSCOIN)	9866-004-009	1
	LABEL-AUSSIEWARNING	8502-698-001	1
	INSTRUCTIONS-AUSSIEADDENDUM	8507-298-001	1

Section 7:

50 Hz Gas Dryer

Key	Description	Part Number	Qty
	FILTER-LINE,EMI	9183-030-001	1
	FILTER-EMI,3A,115/250V	9183-047-001	1
	MOTOR-DRY,MRTHON(30#STK),50HZ	9376-318-001	1
	PULLEY-DRIVE,MACHINED	9453-169-009	1
	CONTROLSASSEMBLY-FENWAL	9857-140-001	1
	CONTROLSASY-ELEC,STKW/D(W/IR)	9857-148-002	1
	TRANSFORMER-CONTROL	8711-008-002	1
	RELAY, Motor Control	5192-288-001	1
	INSTRUCTIONS-TRANSFORMCONNECT	8507-230-003	1
	INSTRUCTIONS-AUSSIEADDENDUM	8507-298-001	1
	LABEL-AUSSIEWARNING	8502-698-001	1
	WIRINGLABEL-SCHEMATIC	9506-168-001	1
	WIRINGLABEL-DIAGRAM	9506-169-001	1

Key	Description	Part Number	Qty
	KIT-HONEYWELLVR86VALVEFLANGE	9732-162-001	2
	CONTROLASSEMBLY-GAS	9857-132-004	1
	Orifice-Natural, #32	9425-069-009	2
	LP Conversion Kit	9732-179-001	1
	Orifice-LP, #50	9425-069-008	2

Wiring Schematic for Dryer 50hz 230V

9506-168-001C

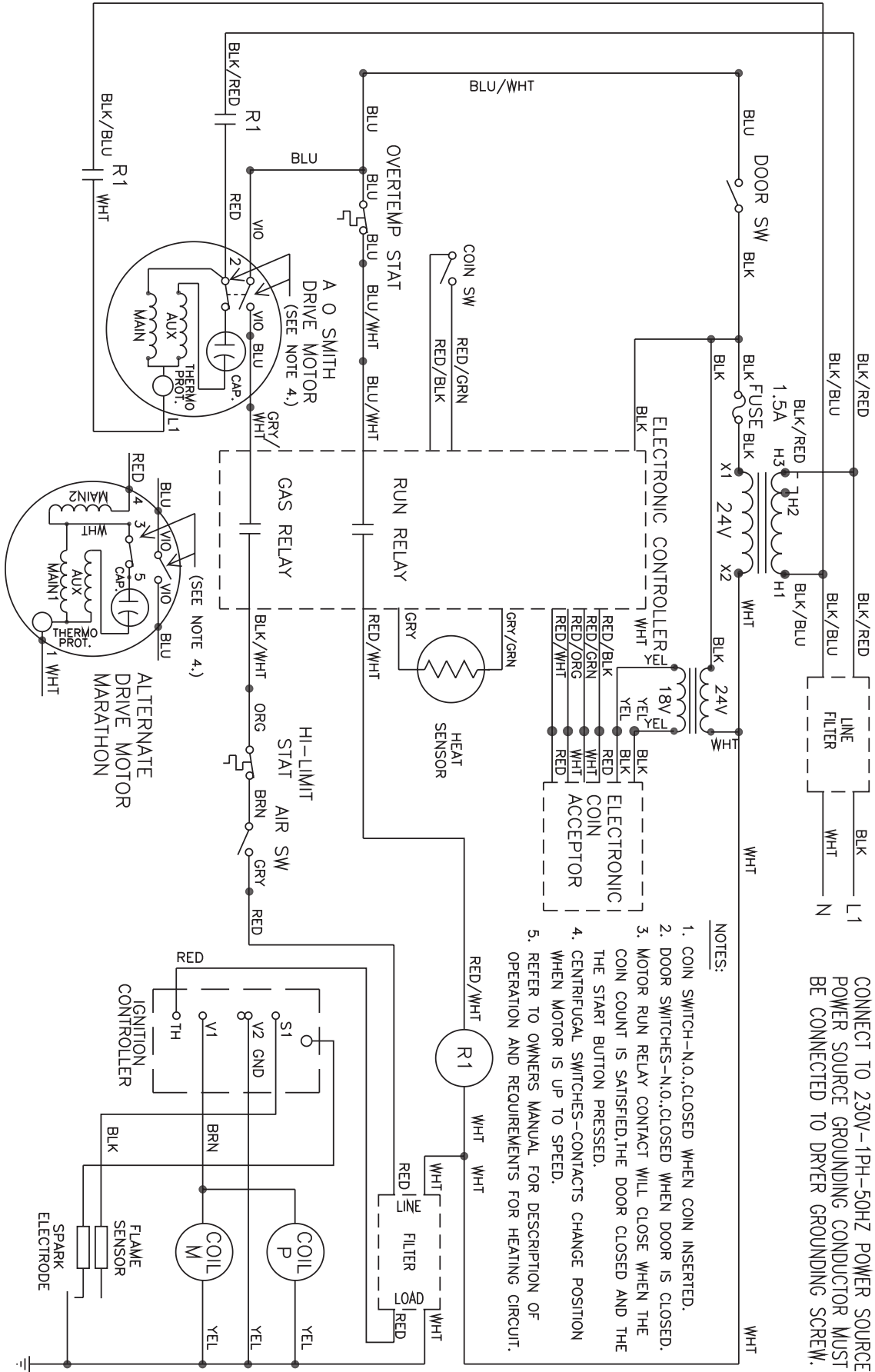

CONNECT TO 230V-1PH-50HZ POWER SOURCE.
POWER SOURCE GROUNDING CONDUCTOR MUST
BE CONNECTED TO DRYER GROUNDING SCREW.

- NOTES:
1. COIN SWITCH-N.O.,CLOSED WHEN COIN INSERTED.
 2. DOOR SWITCHES-N.O.,CLOSED WHEN DOOR IS CLOSED.
 3. MOTOR RUN RELAY CONTACT WILL CLOSE WHEN THE COIN COUNT IS SATISFIED,THE DOOR CLOSED AND THE START BUTTON PRESSED.
 4. CENTRIFUGAL SWITCHES-CONTACTS CHANGE POSITION WHEN MOTOR IS UP TO SPEED.
 5. REFER TO OWNERS MANUAL FOR DESCRIPTION OF OPERATION AND REQUIREMENTS FOR HEATING CIRCUIT.

SCHEMATIC

D_T_30KC_21CR

Wiring Diagram for Dryer 50hz 230V -21CR

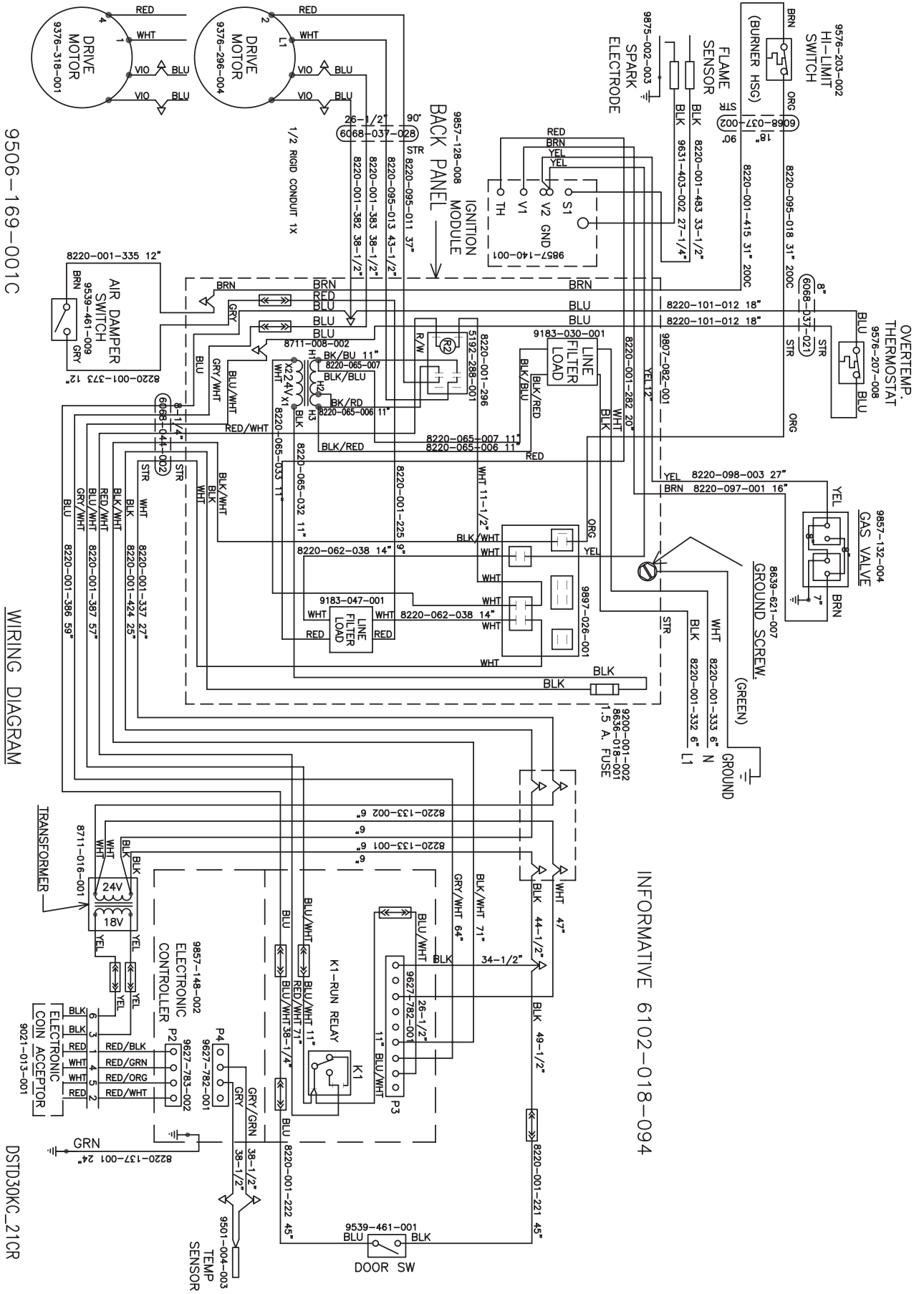

9506-169-001C

WIRING DIAGRAM

DSTD30KC_21CR

INFORMATIVE 6102-018-094

Section 8:

Washer Service and Trouble Shooting

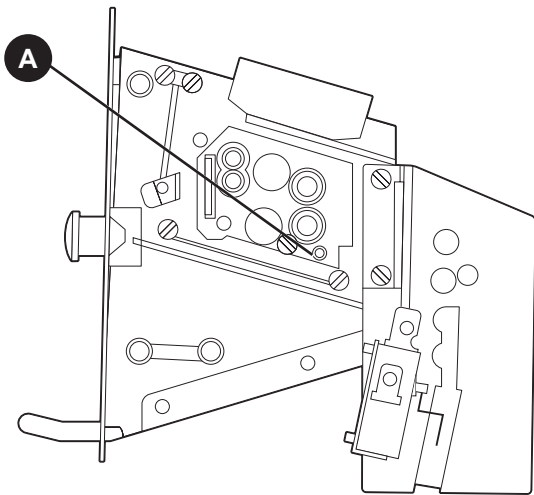

Left View Coin Drop Acceptor

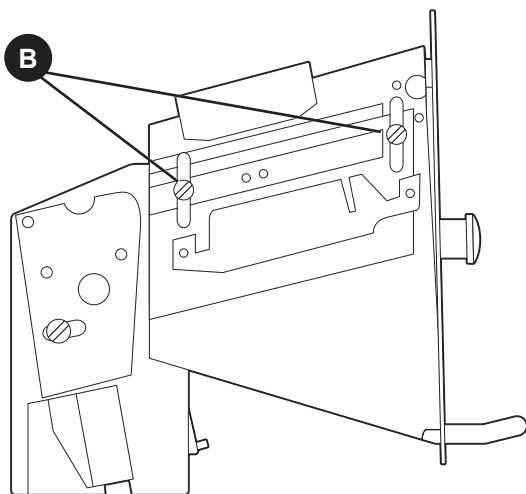

Right View Coin Drop Acceptor

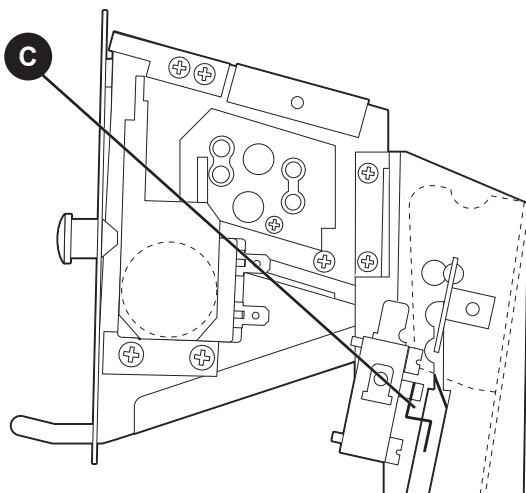

Mechanical Acceptor

Standard Coin Drop Acceptor

The drop style coin acceptor contains a coin switch that is actuated by each good coin that is accepted.

Removal

The coin acceptor is removed by loosening the two Torx T-10 machine screws on the right side and by removing completely the two Torx T-10 machine screws on the left side (#T-10 Torx driver, Dexter Pt. No. 8545-051-003). There are locking nuts on the back side that will have to be held. Needle-nose pliers work well for this. Sliding the acceptor to the left will remove it from the slots in the front panel. This gives access to the coin switch and acceptor for adjustments.

Coin Thickness Adjustment (see diagram)

On the right side of the acceptor there is a coin thickness adjusting screw "A" with a locking nut. To allow for different thickness coins the screw can be turned in to accept thicker coins and turned out to reject thicker coins. Start with a quarter of a turn on this screw and be sure to retighten the lock nut after adjustment.

Coin Height Adjustment (see diagram)

On the left side of the acceptor is a coin height adjusting bar "B". This bar is adjusted by loosening the two mounting screws and moving both ends of the bar up or down equal amounts. The bar should be raised as high as possible while still accepting the correct coins. If it is raised up too high, the good coins will be rejected.

Coin Switch Adjustment (see diagram)

The normally open coin switch "C" should click (close) soon after the coin hits the operator wire. However, there must be enough travel to allow the switch to reset (open) once the coin has passed. Adjustment should be made by bending the wire very close to its attachment point.

Electronic Acceptor Coin Drop (Original Design)

Setting the electronic coin acceptor switches

Some washer models come equipped with an electronic coin acceptor. Follow the instructions below for setting the switches for the desired country and currencies.

1. The electronic coin acceptor has switch settings depending on the coins and country. See the table below for available values of the left and right coin inputs for the available countries.

WARNING: turn power off before and leave power off when changing the switches of the electronic coin acceptor.

2. Turn power back on and test coins to ensure proper operation.

Acceptor P/N	Country	Left Coin	Right Coin	SWs 1-8	SWs 9-16
9021-010-001	Canada	25¢		↓↓↑↑↑↑↑↓	↓↑↑↑↑↑↑↓
	Canada		\$1	↑↑↓↓↑↑↑↓	↓↑↑↑↑↑↑↓
	Canada		\$2	↑↑↑↑↑↓↓↓	↓↑↑↑↑↑↑↓
	Japan	100¥		↓↓↑↑↑↑↑↓	↑↓↑↑↑↑↑↓
	Japan		500¥	↑↑↓↓↑↓↓↓	↑↓↑↑↑↑↑↓
	Taiwan	10NT		↓↓↑↑↑↑↑↓	↑↑↓↑↑↑↑↓
	Taiwan		50NT	↑↑↓↓↑↓↓↓	↑↑↓↑↑↑↑↓
	Korea	500W		↓↓↑↑↑↑↑↓	↑↑↑↓↑↑↑↓
		Greenwald 118-1 Token		↑↑↑↑↑↑↑↓	↑↑↑↑↓↑↑↓
		Greenwald 118-5 Token		↑↑↑↑↑↑↑↓	↑↑↑↑↑↓↑↓
	U.S.A.	25¢		↓↓↑↑↑↑↑↓	↑↑↑↑↑↑↓↓
	U.S.A.		\$1	↑↑↓↓↑↑↑↓	↑↑↑↑↑↑↓↓
9021-011-001	Australia	10¢		↓↓↑↑↑↑↑↓	↑↓↑↑↑↑↑↓
	Australia	20¢		↑↑↓↓↑↑↑↓	↑↓↑↑↑↑↑↓
	Australia		\$1	↑↑↑↑↓↓↑↓	↑↑↓↑↑↑↑↓
	Australia		\$2	↑↑↑↑↑↑↓↓	↓↑↓↑↑↑↑↓
	New Zealand	10¢		↓↓↑↑↑↑↑↓	↑↓↑↑↑↑↑↓
	New Zealand	20¢		↑↑↓↓↑↑↑↓	↑↓↑↑↑↑↑↓
	New Zealand		\$1	↑↑↑↑↓↓↑↓	↑↑↑↓↑↑↑↓
	New Zealand		\$2	↑↑↑↑↑↑↓↓	↓↑↑↓↑↑↑↓
	Hong Kong	\$5		↓↓↓↓↑↑↑↓	↑↑↑↑↓↑↑↓
	Hong Kong		\$10	↑↑↑↑↓↓↑↓	↑↑↑↑↓↑↑↓
		Greenwald 118-1 Token		↑↑↑↑↑↑↑↓	↑↑↑↑↑↓↑↓
		Greenwald 118-5 Token		↑↑↑↑↑↑↑↓	↑↑↑↑↑↑↓↓

NOTE: Coins and tokens in the left coin column will result in one pulse to the left coin input.

NOTE: The \$1, 500¥, 50NT, and \$10 coins in the right coin column will result in one pulse to the right coin input, while the \$2 coins will result in two pulses to the right coin input.

Note: Acceptance of multiple coins per country and multiple tokens is allowed. Only the down/off setting for each coin and token is required to accept that coin or token.

Maintenance Instructions -Electronic Acceptor (Original Design)

1. Instructions to open the flap of the coin selector

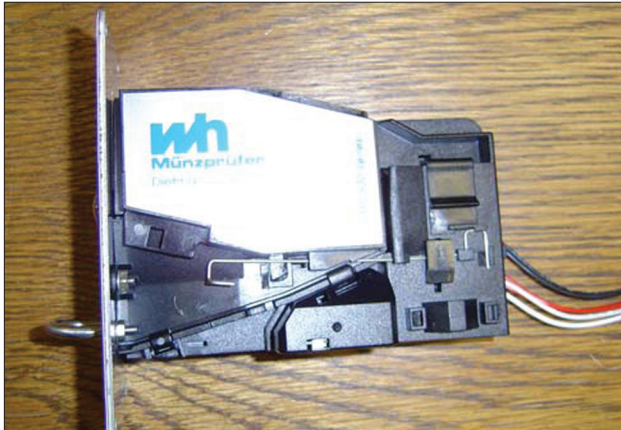

Original situation

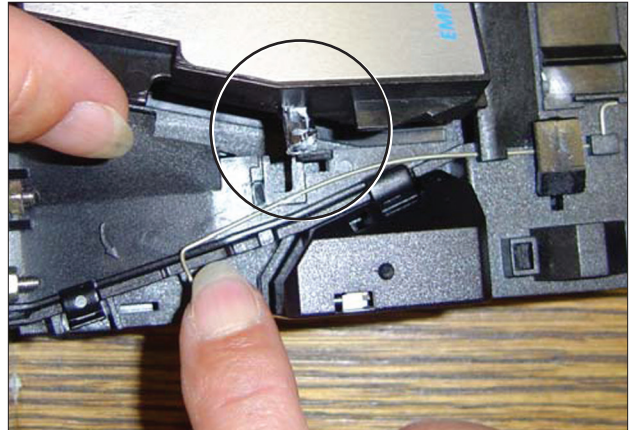

Move spring downwards to free the catch.

NOTE:

- Do not lift the spring
- Do not over bend the spring in any direction.

Open the flap of the coin selector.

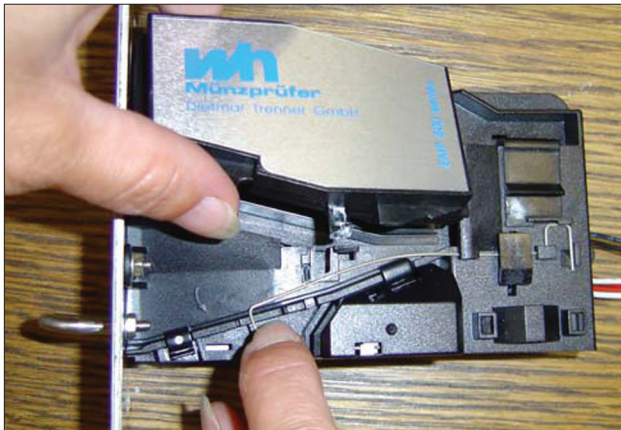

2. Assembly instructions to change a spring

Lift the right end of the spring by means of a screw driver.

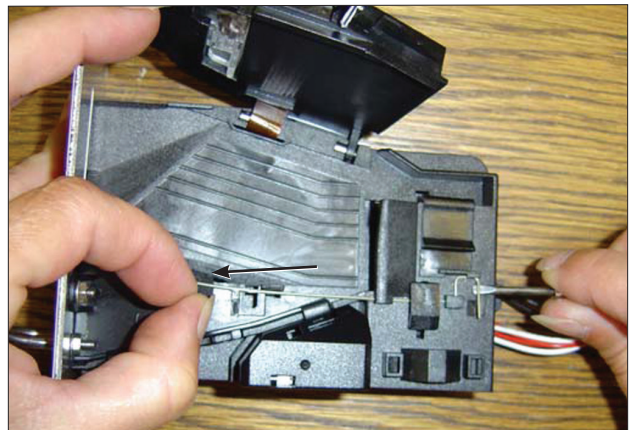
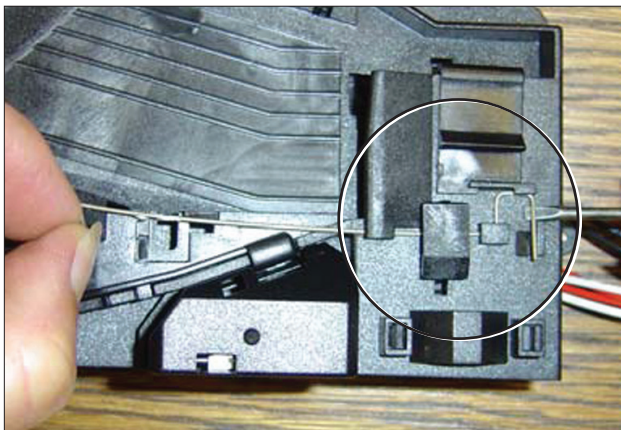

Pull the spring approximately 3 mm to the left.

Maintenance Instructions -Electronic Acceptor (Original Design)

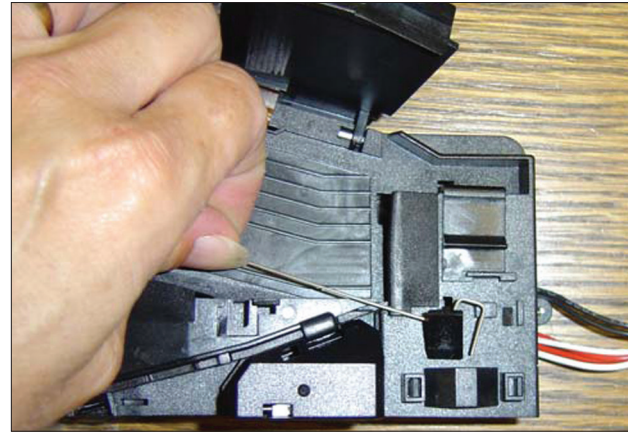
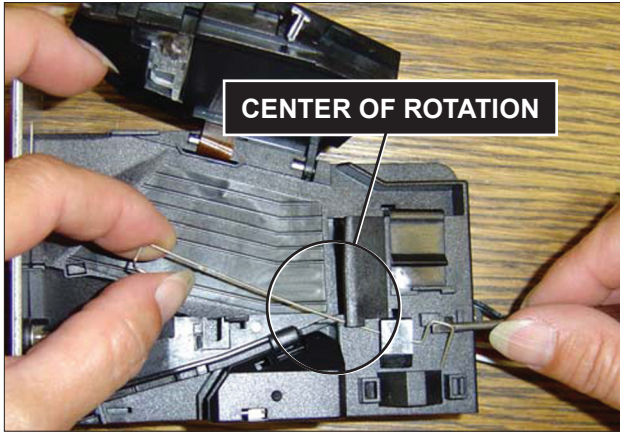

Rotate the spring clockwise for about 40 to 60 degrees until it becomes free of the protrusion. Lift off the spring with the attached plastic part.

3. Assembly of a new spring

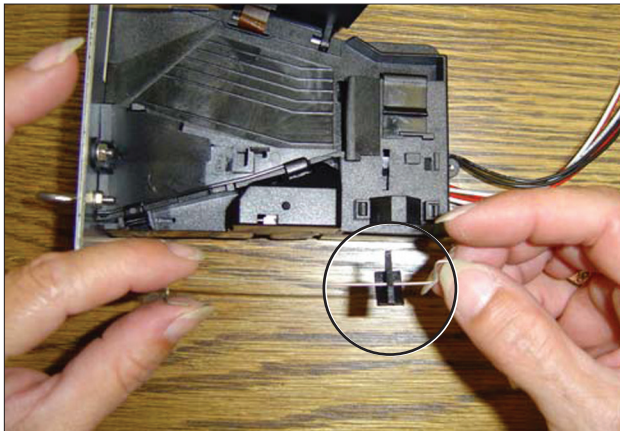

Attach the plastic part to the new spring.

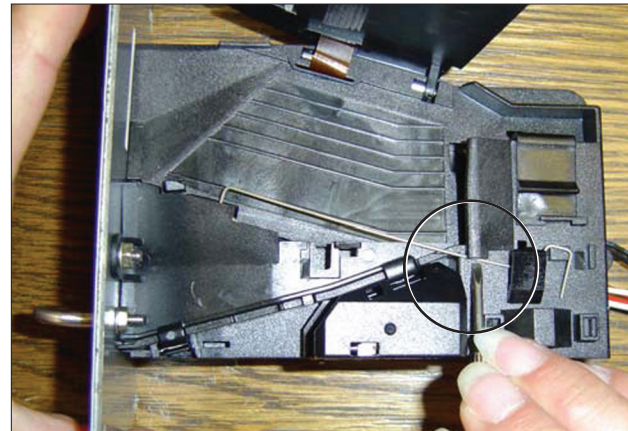

Place the plastic part in its position (slot).

Push the spring below the protrusion by means of a small screw driver.

Push the spring lateral to the right until its snaps

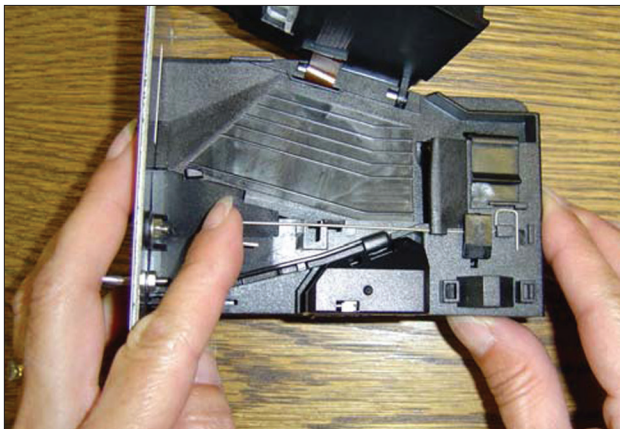

into its proper position.

Maintenance Instructions -Electronic Acceptor (Original Design)

4. Close the coin selector

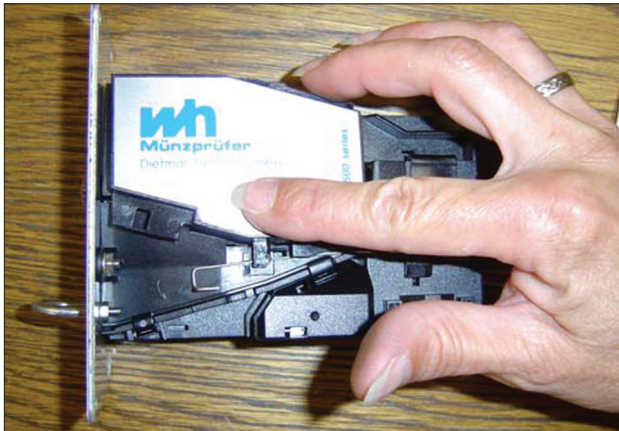

To shut the coin selector follow pictures 1 to 3 in reverse order.

5. Cleaning the electronic coin selector

The EMP 500 v4 is an extraordinarily robust coin selector and operates relatively maintenance free. However, it should be cleaned at regular intervals (minimum once a year) especially if it is operating in an environment with high levels of dust, smoke or nicotine. The cleaning intervals are of course dependent on the level of air borne contaminants.



Clean the coin path with a soft brush and wipe the exposed surfaces. Use an alcohol moistened cloth.



If you find solid residues stuck to the coin rail (patina) remove it with an alcohol moistened cloth.

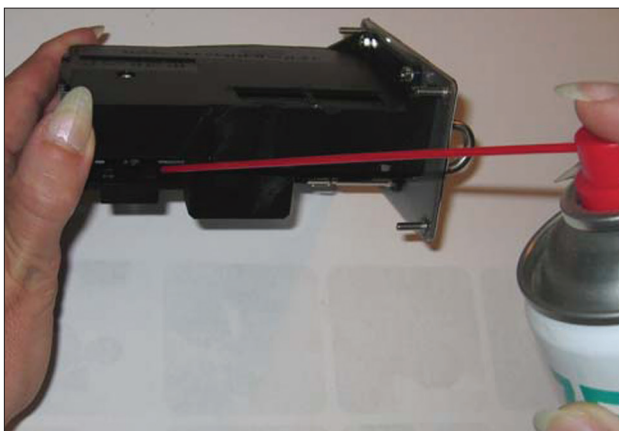

Optical sensors may be cleaned with a soft brush or very carefully with an air spray duster.

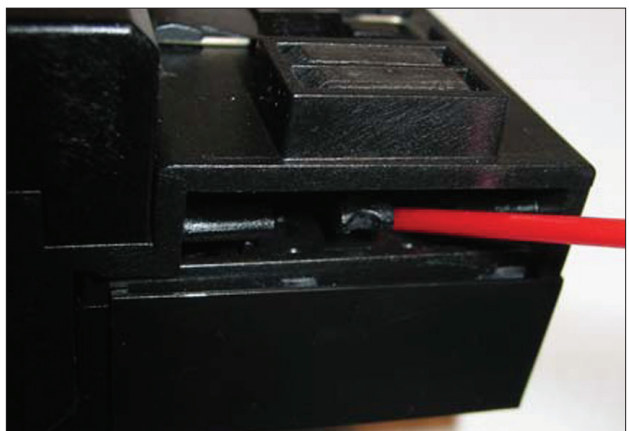

Location of the optical sensor within coin outlet.

Maintenance Instructions -Electronic Acceptor (Original Design)

6. Adding the bolt #4036

A bolt can be added to the EMP 500 v4 to reduce attempts of vandalism or to protect the unit from improper use. Please note that some front plates/cashboxes might not allow mounting this additional device.

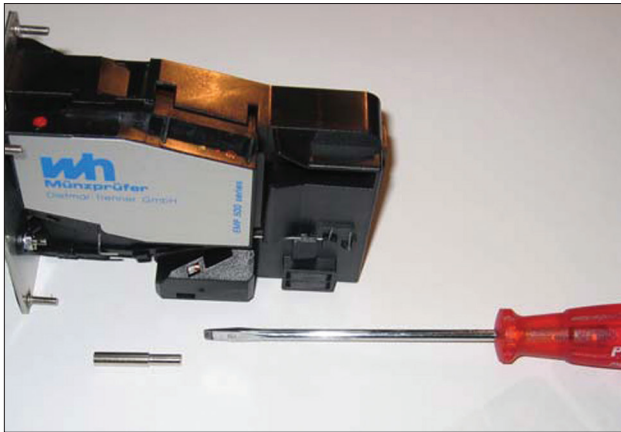

The bolt (part number 4036) should be mounted with the help of a screw driver.



Screw the bolt onto the existing stud weld on top of the nut which fixes the reject bracket.



Once the bolt is fixed, please verify the position of the spring as indicated in the picture.

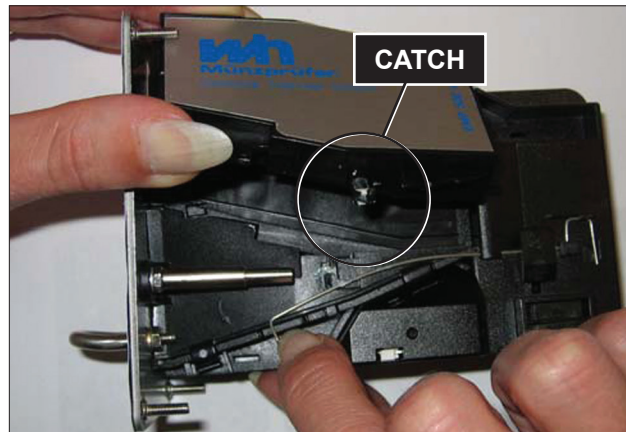

To open the selector move spring downwards to free the catch.

Front Panel Removal

- Step 1:** Remove the screws from front panel.
- Step 2:** Remove the harness connections from the control boards on the back of the front panel
- Step 3:** pull back the front panel and set it aside.

Back Panel Removal

- Step 1:** Remove all screws holding back panel in position except the bottom row.
- Step 2:** The bottom row of screws are slotted and only need to be loosened and to lift off panel.

NOTE: The back panel is not only a safety requirement but also contributes to the rigidity of the cabinet.

Drain Valve Access

For access to drain valve, remove the front panel. The drain valve is a ball type and is powered closed by the drain valve motor. It is mounted under the washer tub on the left side. It is spring loaded open. If power is interrupted to the washer, the motor releases the sealing ball, allowing the drive spring to open the valve. With the valve open, all water in the washer will drain out.

Drain Valve Cleaning

- Step 1:** Loosen the clamp on the tub hose at the drain valve end and remove the hose from the drain valve.
- Step 2:** Loosen the drain hose clamp on the back of the drain valve. Remove two drain valve mounting racket screws from the frame of the washer.
- Step 3:** **Disconnect brown/yellow & blue wire connection at clear connector.**
- Step 4:** Remove the drain valve and bracket assembly. Unplug the wiring after the drain valve is removed from the washer.

Masking Ring (door lock cover) Removal

- Step 1:** Remove front panel.
- Step 2:** Remove 4 nuts (3/8" socket) that retain masking ring.
- Step 3:** Move it to the left and off.

Detergent Dispenser

The detergent dispenser is located at the top of the front panel. it is fed water from the vaccum breaker assembly at the rear of the machine to flush the soap with hot water during the wash bath and the fabric softener with cold water during the rinse bath.

Vacuum Breaker (also called an air gap)

In the left rear of the cabinet is the vacuum breaker. It guides the water to the tub and dispenser and prevents a back flow of water.

Water Valves

Remove panel to access water valves at rear. The two dual outlet water valves are mounted to this plate. Always check inlet screens to be sure that they are clean. Disassembly of valve requires the removal of two solenoid screws and three valve body screws. Insi de the solenoid coil is a solenoid guide, armature, armature spring and diaphragm. All valve parts are available individually or as a complete unit.

Door Locking Solenoid

The door locking solenoid is powered shut with control voltage to lock the door and releases when voltage is removed. It is located in the left front corner of the washer.

Thermoactuators

The thermoactuators are a safety device that keeps the door from immediately unlocking if power is lost while the machine is operating. They are mounted under the door locking solenoid.

Lock Thermoactuator

Control voltage is applied to the lock thermoactuator at the beginning of the cycle making it extend and block the door locking solenoid. This keeps the door locked for approximately two minutes after a power failure occurs. The lock thermoactuator does not delay the door opening at the end of a normal cycle.

Unlock Thermoactuator

To insure that the lock thermoactuator has retracted by the end of the cycle, one minute prior to the end of the cycle, the unlock thermoactuator is powered with control voltage making it extend and unblock the door locking solenoid.

Drive Belt Removal

Turn the drive belt(s) off the basket pulley first and then remove from the motor pulley.

Reverse this procedure for installation.

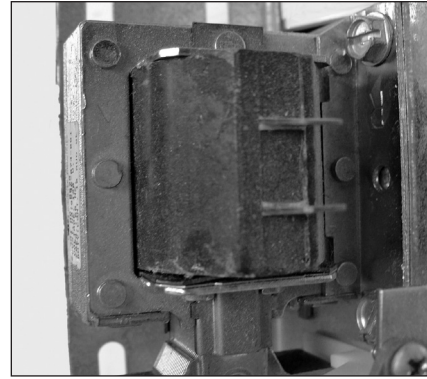

Door Lock Solenoid

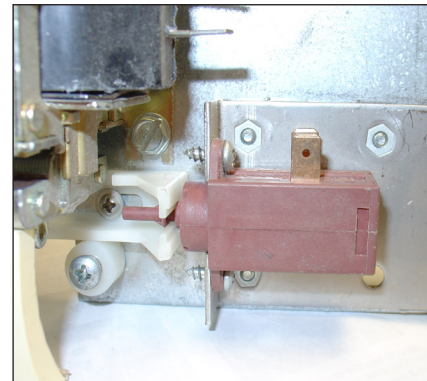

Thermoactuator



Drive Belt

Door Lock Assembly Operation

After loading the clothing, the door should be closed and latched. The locking cam on the door contacts the latching switch actuator which closes the latching switch. The specified number of coins should now be added to start the washer. The solenoid pulls up on the locking pawl by use of a linkage rod. The locking pawl has two jobs. The first is to lock the door. This is accomplished by blocking the locking cam on the door so that it can't rotate to unlock. The second job is to close the two piggyback lock sensing switches. These switches control power to all of the controls. If the door unlocks for any reason, these two switches will stop the machine. When the door handle is 1/4 to 1/2 of an inch from its fully closed position, the latching switch should close. The two piggyback lock sensing switches should be open when the door is unlocked and should be closed when the door is locked.

Accessing the Door Lock Assembly

After removing the front panel and masking ring, the door lock assembly can now be accessed.

Adjustment for Door Lock Assembly

The latching switch and the piggyback lock sensing switches all have slotted mounting for easy adjustment.

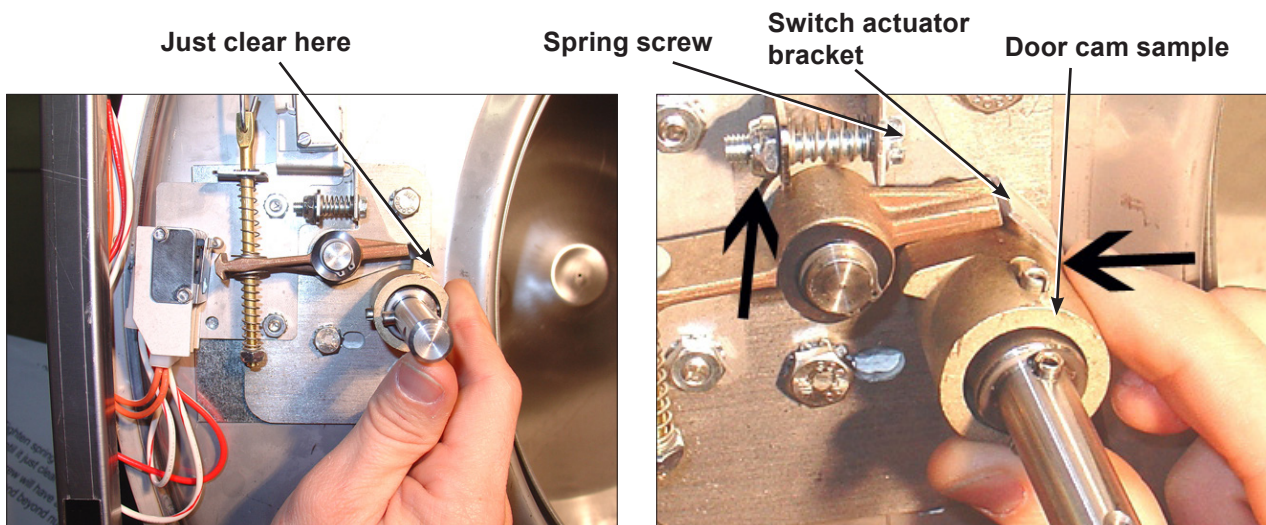

Step 1: Set door cam over pin. Here you can see the door cam away from the door lock assembly.

Step 2: Tighten spring screw on switch actuator bracket arm until it just clears cam OD. at base of door lock assembly.

Adjustment to this bracket usually is not necessary as next step is used more in field.

Flat blade screw on door switch latching

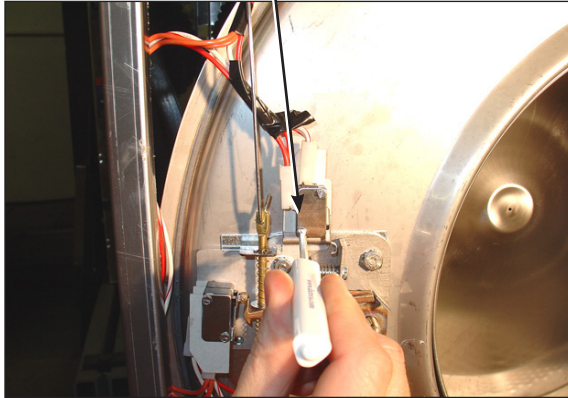

Step 3: With switch actuator bracket adjusted you will now need to adjust single switch by loosening 2 flat blade screws and allowing swivel of switch. Move switch towards above bracket until it actuates. Now tighten flat blade screws. Use a .040 thickness guage to insert between bracket and switch and the switch should close and open again upon removal of thickness guage.

Door cam check position

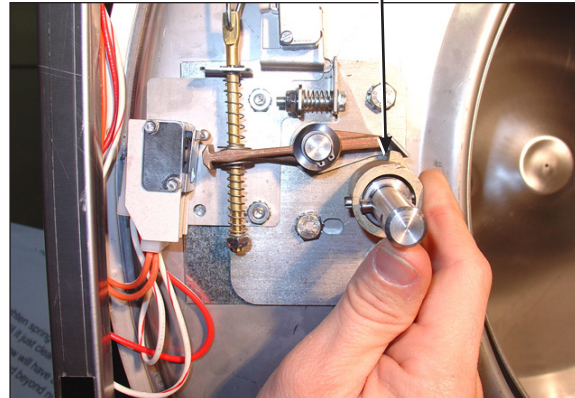

Step 4: Check for switch actuation at partial turn of cam as in operation above. Door handle goes from horizontal to six o'clock vertical.

Adjustment screw for (piggyback switches)

Door lock rod Locking pawl blocking

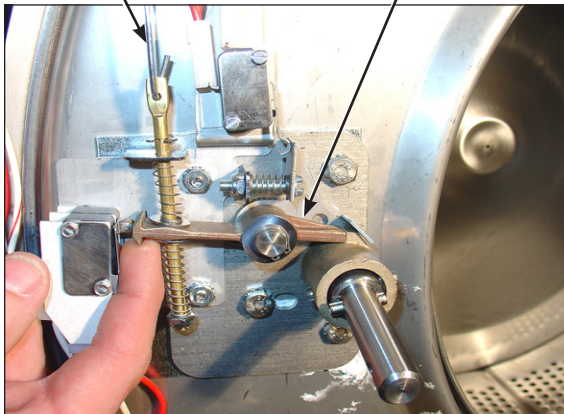

Step 5: Check that lock pawl arm swings to cam lobe to lock position.

Top of flat end of locking pawl.

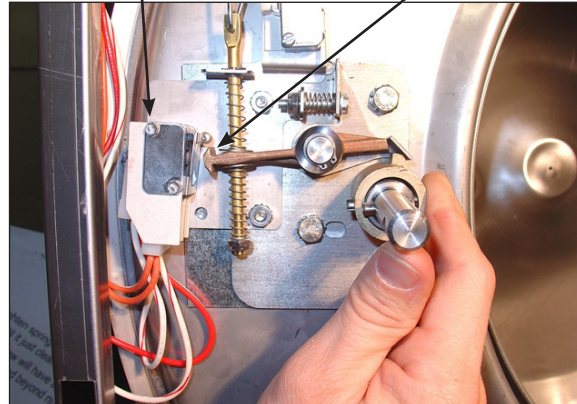

Step 6: The lock stacked switches (piggyback) must be adjusted as door lock solenoid pulls up on door rod and locking pawl is now blocking door cam from turning and is in full up position. The stacked switches (piggyback) have a single actuator arm and it must actuate when single actuator roller wheel rolls to flat side of locking pawl. You will also notice a .040 gap between actuator arm and switch bodies.

Note: Both stacked switches must operate together!

Adjusting the Loading Door

The door can be adjusted by changing the number of shims behind the door hinge and the door lock assembly. The vertical fit of the door to the tub can be altered by loosening the door hinge bolts and raising or lowering the door before retightening. It is important for the door to be centered on the tub front. By chalking the front of the tub and closing the door to transfer that line to the gasket, the centering can be evaluated. It is also important for door pressure to be similar around the door perimeter. Door pressure can be evaluated by inserting a dollar bill in several positions and tugging on it. See Parts Section for kit to increase door sealing pressure.

Loading Door Removal

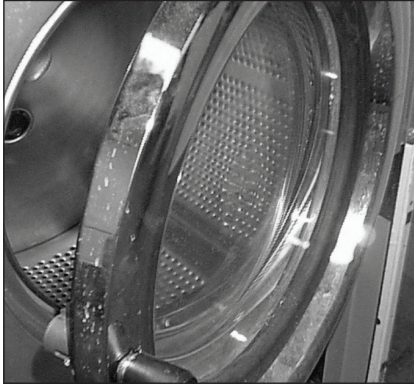

Step 1: Support door to prevent dropping.



Step 2: Remove 3 bolts holding hinge retainer clamp and set door off.

NOTE:

Door hinge mounting bolts penetrate tub front and require silicone sealer applied to holes when reinstalling.

Loading Door Disassembly

Step 1: Remove the loading door as outlined above. Lay the door on a flat surface with the glass down.

Step 2: While holding down on the door glass, lift up on the door ring and roll back the lip of the gasket with your fingers.

Step 3: Work all the way around the gasket and the glass is out.

Loading Door Hinge Removal

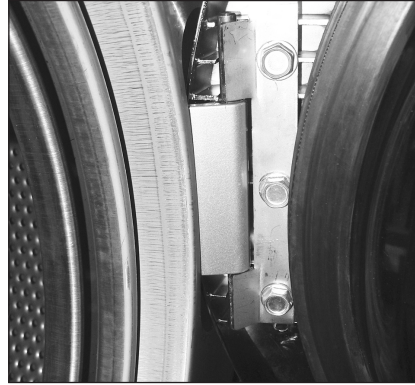

Step 1: First remove loading door, front panel, and trim ring.



Step 2: Remove 3 screws holding door hinge. Shims may be present between hinge and tub front. The number may be increased or decreased to adjust right side door pressure.

Loading Door Reassembly

Step 1: Lay the door ring face down on a flat surface. Start the glass into one side of the door gasket.

Step 2: Use one hand underneath to push the gasket out and the other hand on the top pulling the gasket in place.

Step 3: The front lip of the door gasket should be checked for proper seating.

Control Panel Name Plate Decal

The name plate on washer front is adhesive backed.

Control Panel Name Plate Removal

The name plate may be removed by simply peeling it off.

Re-Installation of Name Plate

Step 1: Remove any remaining glue from the control panel.

Step 2: Before removing the paper backing from the name plate, check fit to the control panel. The program push buttons are the locating guides.

Step 3: Remove the paper backing from the right side of the name plate, position it on the panel and press right end into place. Peel the backing from the left end and press into place.

Tub Back, Bearing and Cylinder Assembly

Removing the Washer Tub Assembly from the Washer Frame

Step 1: Remove the left and right lower front panel screws that retain the panel to the chassis.

Step 2: Remove the Drain Hose from the bottom of tub assembly.

Step 3: Remove Overflow and Tub vent hoses at rear tub back.

Step 4: Remove the pressure switch hose from the bottom of the switch.

Step 5: Disconnect the door lock wires from all switches and the door lock solenoid. The following illustration of their locations should be consulted.

Step 6: Disconnect pull rod between solenoid and door lock assembly.

Step 7: Disconnect the wires to the drain valve at the bottom of the machine.

Step 8: Remove 4 (four) bolts at outer tub and slide complete assembly out front . (Note: very heavy, use appropriate devices)

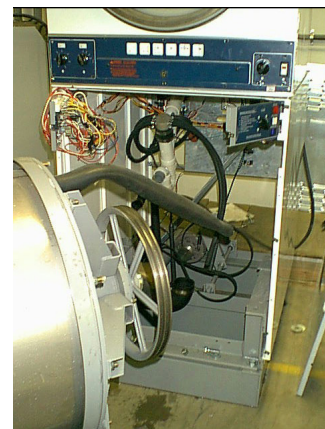

Tub Back, Bearing and Cylinder Assembly

Removal

- Step 1:** Remove the tub and cylinder as described previously
- Step 2:** Remove the overflow hose, tub fill hose and pressure switch hose from the back of the tub.
- Step 3:** Mark the tub back and bearing assembly for ease in assembly later. (see picture)
- Step 4:** Remove the 12 bolts and nuts from the perimeter of the tub back clamp ring. (Two of the twelve bolts are longer and go through the thicker part of the brace where it connects to the frame.)
- Step 5:** Remove the 2 bolts that fasten the clamp ring to the frame.
- Step 6:** The entire tub back and cylinder assembly may be lifted out of the tub (it may be necessary to break the adhesion of the silicone that seals the tub back to the tub). Blocks should be placed under the edges of the cylinder before setting it down to prevent damage to the cylinder flange.

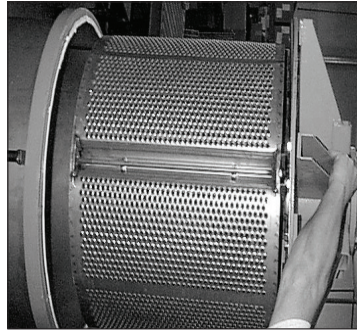

Reassembly

Reverse the procedures to the left paying attention to the following areas

- Step 1:** Lay the tub and cylinder on its front. Note: Put a thick pad across the front of the washer, above the door, to protect the tub front
- Step 2:** Make sure the bearing housing weep holes are located at 12 o'clock and 6 o'clock.
- Step 3:** Clean the silicone rubber from the back of the outer tub and the perimeter of the tub back where the two meet. There is no gasket in this area.
- Step 4:** Apply a new bead of silicone rubber around the back of the outer tub. (see picture)
- Step 5:** Lower the tub back, bearing and cylinder assembly into the washer outer tub.
- Step 6:** Torque all bolts according to the following charts.
- Step 7:** Use a puller to remove the pulley from the shaft.

Basket Pulley, Bearing Housing, Water Seals and Tub Back

The cast iron basket pulley is retained by a bolt, locking washer and a flat washer.

Removal

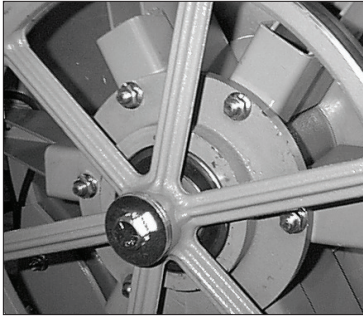

- Step 1:** Insert a large screw driver or punch through a spoke in the pulley into the bearing housing support. This keeps the pulley from turning.
- Step 2:** Remove the retaining bolt, lockwasher and flat washer and reinstall just the bolt
- Step 3:** Use a puller to remove the pulley from the shaft. Watch for tolerance ring.

Reassembly

- Step 1:** Make sure that the tolerance ring is in place inside the pulley.
- Step 2:** The shoulder inside the pulley that holds the tolerance ring should face the back of the washer when installed correctly.
- Step 3:** Use a stack of flat washers and a longer bolt to press the pulley onto the basket shaft.
- Step 4:** Reinstall the retaining bolt, lock washer and flat washer. The shaft end bolt with washer should be installed with a torque value listed in charts in this manual.

Removal of Bearing Housing From Basket Shaft, Bearings and Water Seals



- Step 1:** To remove the tub back assembly, the 6 bolts attaching it to the bearing housing must be removed.
- Step 2:** Remove water seals from the seal mounting plate on the cylinder shaft. These are removed with your fingers.
- Step 3:** The retaining ring next to the front bearing must also be removed.
- Step 4:** The bearings are pressed into the housing and must be pressed

Reinstallation onto Basket Shaft

- Step 1:** Carefully set the assembly over the shaft engaging the bearings and bearing spacer.
- Step 2:** The tolerance ring that fits inside the pulley should be placed in position (see Basket Pulley Reassembly for correct positioning).
- Step 3:** The pulley should then be started onto the shaft. A stack of flat washers and a longer pulley bolt will be required to pull the basket shaft through the bearings and pulley.
- Step 4:** Install the shaft end bolt with washers and torque to specifications in Bolt Torque Chart.
- Step 5:** See Tub Back, Bearing and Cylinder Assembly for installation of complete assembly back into washer.

Reassembly

Step 1: When installing new bearings into a bearing housing, first press the front (large) bearing into the housing until it bottoms. With the bearing spacer in place, press the rear bearing in until the spacer is snug between the two bearings. Be sure and reinstall the retaining ring in front of the front bearing (see picture).



Step 2: The tub back assembly should be reattached to the bearing housing with the 6 mounting bolts and torqued according to the torque chart.
Note: The bead of silicone that seals each bolt to the tub back. This must be cleaned and replaced upon reassembly (see picture).

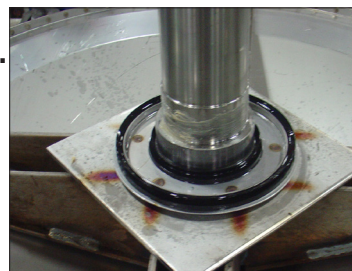

If the 6 support assemblies have been removed from the bearing housing, the 6 rear bearing housing bolts should be torqued according to the chart also.

Step 3: The primary and secondary seals that mount on the sealing ring may be slid over the shaft and seated on the metal sealing ring. In the unlikely event that the metal ring that mounts these sealing rings were to be damaged or moved, a new one would need to be pressed on. The ring must be pushed against the stop on the shaft. Before installing the new sealing ring, a bead of silicone should be put on the basket shaft (see picture). After installing the seals, lubricate the faces of the seals with silicone grease (see picture).



Removal

Step 1: Remove the drive belt as explained in previous instructions.

Step 2: Remove the tension spring and bracket.

Step 3: Disconnect the motor wires in the control area at the top of the machine. The motor wire retaining clamp should be removed and reused. There is a diagram showing where each motor wire plugs in so there is no need to mark them.

Step 4: Loosen the set screws on the motor support shaft.

Step 5: Remove the retaining bolt from the front of the support shaft.

Step 6: Remove the motor support shaft.

Step 7: Lift motor out of machine. Note: On larger washers it is advisable to put a board under the motor and slide it out rather than lifting it.

Bolt Torque Chart

Bolt Size	Where Used	Torque
1/2"x 1 1/4" bolt	Tub End of Bearing Hsing. 9545-017-009	70-110 ft/lbs
5/8"x 1 1/2" bolt	Tub End of Bearing Hsing. 9545-060-001	120-150 ft/lbs
1/2"x 1 1/4" bolt	Mtg. of Tub to Cradle Asy. 9545-017-009	70-110 ft/lbs
5/8"x 2 1/2" bolt	Mtg. of Tub to Cradle Asy. 9545-060-001	120-150 ft/lbs
3/8"x 1 1/2" bolt	Tub Back Ring to Tub Back 9545-029-003	45-80 ft/lbs

Control Mounting Trough

Remove rear panel to access control trough. It sets on the right side of the machine and holds the control PCB's, transformers, and pressure switch.

Main Data Communication Cable

Goes between front PCB board and Variable Frequency Drive unit mounted center rear of machine. It has telephone type connectors at each end and is inserted at Controller PCB and the Variable Frequency Drive.

Circuit Breaker/Fuse

The fuse (optional circuit breaker) mounts to the rear channel. It carries all of the controls in the machine but does not include the motor. To reset the circuit breaker just push in the button. If you have a fuse then remove fuseholder and fuse and replace with a 1 1/2 amp fast blow type fuse.

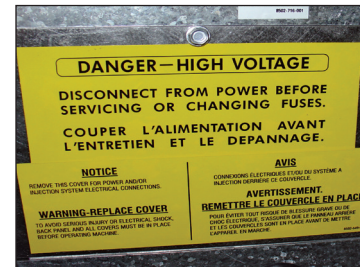

Fuse Location

Main Control Printed Circuit Board

Please be sure to be grounded to machine before removal of this board from machine. PC board mounted vertically behind front control panel. Remove hold down nuts in 4 corners and 1 at bottom center.

PCB Transformer Step-down

Small transformer mounted at front of control trough that is powered with 120 VAC primary and two secondary outputs of 2.3 VAC and 24-27 VAC.

Controls Transformer

This transformer is mounted at the back of the control trough and steps a range of 208 to 240 volts down to 120 volts for the controls. There are two terminals on the controls transformer for incoming power. One terminal tap is marked for 208 volts use this tap for measured voltage of 200 volts - 215 volts. and the other tap is marked 230 volts for 216 volts - 240 volts. Note: All washers have a controls transformer. Always check the incoming voltage and use the appropriate transformer terminal when installing ALL washers.

Main Relay Printed Circuit Board

Please be sure to be grounded to machine before removal of this board. PCB mounting horizontal in control trough towards front of machine. Remove 4 mounting nuts.

LED Printed Circuit Board Temperature & Start Display/Push-Button

The selector switch is mounted in the center of the control panel and is held in place with five nuts. It allows the selection of hot, warm or cold water temperatures. Note: Do not over tighten on reinstallation as the switch can be damaged, stay pushed in and will cause erratic displays.

Add-Bleach LED

This LED light indicates to the user the correct time to add bleach. This LED is polarity sensitive and must be connected correctly.

Pressure Switch **Caution (Not recommended by Factory!) Changing Factory preset adjustment voids all factory water usage specifications.**

The pressure switch sets the water level in the washer. As the water level rises, it compresses the air in the pressure switch hose. When the washer reaches the desired water level, the compressed air in the pressure switch hose opens the contacts in the switch, shutting off the water. When at the empty level, the pressure switch

SINGLE LEVEL

DUAL LEVEL

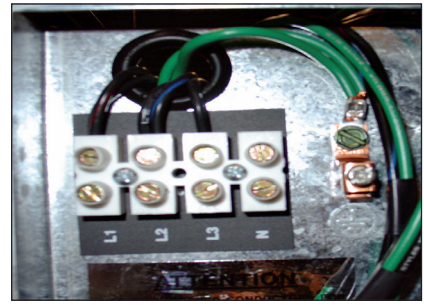
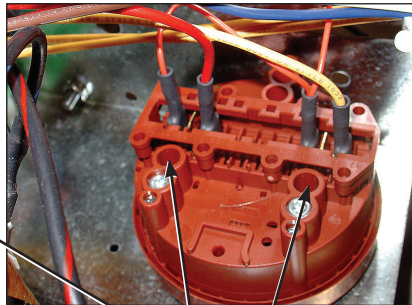
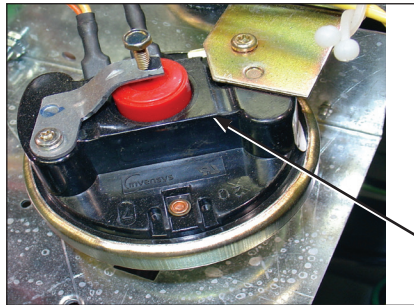

Pressure Switch

Adjustment

Rear

contacts are closed allowing the machine to either spin or fill with water. The 1/4" screw in the middle of the switch adjusts the water level. Counter clockwise will lower the water level, and clockwise will increase the water level. Before making any adjustments of the pressure switch, drain the tub and blow the hose clear of possible water bubbles which can cause erratic pressure switch operation.

Emergency Stop Button Switch Assembly

The stop button is mounted on right side of machine. Remove the top and access the rear of button. Remove the plastic retainer by unthreading CCW. The switch assembly will have to be removed by pressing down on the plastic clip while pulling the switch body away from the stop button.



Temperature and Start Display

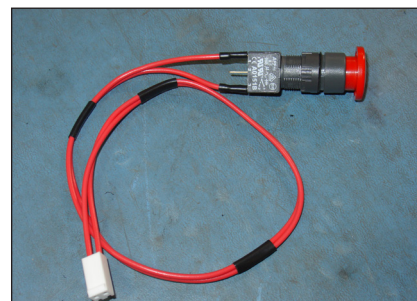

Stop Button Switch Assembly

Power Connection Terminal Block

This terminal block sets at the very back of the control trough. Incoming power to the washer should connect here. (see Electrical under Installation and Operation Section for exact connections)

Delta Variable Frequency Drive:

Main power is connected to terminals L1, L2, and L3 on the Delta drive. If the washer is connected to a three phase source, there should be voltage present on all three terminals. If the washer is connected to single phase power, there should be voltage present on terminals.

The voltage should measure 208 Volts to 240 Volts A.C. between phases and connected to if connected to three phase). There is a tolerance of + 10% on the mains voltage (187 Volts to 264 Volts).

Delta VFD Motor Leads:

The wires from the motor are connected to terminals T1, T2, and T3. Since this drive uses pulse width modulation, an accurate current or voltage reading is not possible. Although an accurate current reading is not possible, a balanced current reading should be present while the motor is running.

Delta VFD Dynamic Braking Resistors:

Three 200 Ohm braking resistors are connected in parallel and attached to the drive at terminals B1 and B2. These resistors allow voltage, which is generated by the motor when decelerating, to be dissipated. They will become hot while the motor is slowing down, so care should be taken so as not to come in contact with them. This will prevent an electrical shock and/or a physical burn.

Delta VFD Cooling Fan:

There is a cooling fan attached to the bottom of the Delta drive. This fan will operate when the internal temperature of the drive reaches a predetermined level, the same way the radiator fan in a newer car operates. **THE FAN CAN OPERATE ANYTIME POWER IS APPLIED TO THE DRIVE!** Remove power to the drive if work is required around the fan.

Common Washer Troubleshooting Solutions

Symptom	Probable Cause	Suggested Remedy
Machine does not start	Power Supply	Check these areas: Circuit breakers, Voltage, Power leads, Power connections. Is front display LED showing a dollar amount.
	Door Switch	Check for continuity through door switch when door is closed. If no continuity, adjust or replace door switch.
	Control Breaker or Fuse	Check 1.5 amp (T-1200. uses 2.5amp) breaker or fuse for continuity. If no continuity, replace breaker or fuse.
	Control Transformer	Check voltage output from control transformer for 120VAC. If voltage is incorrect, replace transformer.
	Coin Acceptor	Check coin switch to make sure coins trip switch and give continuity across switch when closed. If no continuity, adjust or replace switch.
	Check PCB board	Check all wire connections for sure contacts.
	Check wiring between PCB	Check data cable phone type connectors unplug and VFD and replug with power removed.
	Check Relay PCB	Check all wire connections for sure contact.
	Check Door Solenoid	Check that 120 v power is at solenoid after start button is pushed.
Machine will not accept and count coins	Coin Acceptor	Check coin acceptor switch for any type of blockage or damage. Clean, adjust or replace the acceptor.
	Power Supply	Check these areas: Circuit breakers, Voltage, Power leads, Power connection
	Door Closed Safety Switch	Check door closed switch at door hinge for proper operation.
	Door Handle Closed Switch	Check single door closed switch at left side of door handle to close when handle is vertical.
	Control Breaker or fuse	Check 1.5 amp (T-1200 uses 2.5 amp) breaker or fuse for continuity. If no continuity, replace breaker.
	Main PCB	Replace
Door does not lock	Check display for fault code	Does F1 show on the front of display. If yes follow tests described in fault code section.
	Door locking solenoid	Check to insure that solenoid is receiving 120VAC from main relay PCB. If it is, replace solenoid.
	Door Switch	Check for continuity through door latch switch when door closed. If no continuity, adjust or replace door switch.
Door will not open	Thermoactuator	Check to see if thermoactuator(s) and/or its mechanism is stuck or binding and not allowing the door lock solenoid to open. Check to be sure that the locking thermoactuator is not receiving 120VAC during the last 1 1/2 minutes of the cycle. Also check to see that the unlocking thermoactuator is receiving 120VAC during the last minute of the cycle. If the thermoactuators do not receive voltage at the correct times, change the timer. If the timing and voltage are correct, replace the thermoactuator.

Symptom	Probable Cause	Suggested Remedy
Door will not open	Door Rod	Check to see that door rod from solenoid to lock ass'y is long enough to allow lock ass'y to disengage. If not, adjust rod.
	Door Lock Solenoid	Check that door lock solenoid is not stuck closed. If stuck, replace solenoid.
No hot water in detergent dispenser	Water Valve Coil	Check coil continuity at terminals and replace if no continuity. 120 V power only on for 20 second in wash bath.
	Water Inlet	Check water inlet screens for blockage and clean screens if necessary.
	Water	Check to insure that water is turned on and operating.
	P-20 Wire Harness	Check black & white harness.
Symptom	Probable Cause	Suggested Remedy
Hot water does not enter tub in wash	Water Valve Coil	Check coil continuity at terminals and replace if no continuity. Check for 120 V power from main relay PCB
	Water Inlet	Check water inlet screens for blockage and clean if necessary screens
	Water	Check to insure that water is turned on and operating.
	Blk or Wht wire at main controller	Check black or white wires at Molex plug on PCB at main controller and at relay PCB.
	Pressure Switch	Check pressure switch continuity between terminals . If no continuity, check pressure switch hose for obstruction. If hose okay, change pressure switch.
No cold water to tub in wash	Water Valve Coil	Check coil continuity at terminals and replace if no continuity.
	Water Inlet Screens	Check water inlet screens for blockage and clean if necessary.
	Water	Check to insure that water is turned on and operating.
	Blk or whit wire at controller and main relay PCB	Check black or white wires at Molex plug on PCB at main controller and at relay PCB.
	Pressure Switch	Check pressure switch continuity between terminal contacts. If no continuity, check pressure switch hose for obstruction. If hose okay, change pressure switch.
Water comes in but level does not rise	Drain Valve (open)	Check these areas • Drain valve blockage • Drain valve motor and gear train. If power but drain valve does not close, replace valve. • Power to the drain valve. If no power to drain valve, check (brn/yel) circuit for power.
	Blk or whit wire at controller	Check black and white wires at molex plug on main PCB controller and at main relay PCB
Water does not flush softener compartment.	Water Valve Coil	Check coil continuity at terminals and replace if no continuity.
	Water Inlet Screens	Check water inlet screens for blockage and clean if necessary.
	Water	Check to insure that water is turned on and operating.

Common Washer Troubleshooting Solutions

Symptom	Probable Cause	Suggested Remedy
Water does not flush softener compartment.	Pressure Switch	Check pressure switch continuity between terminals. If no continuity, check pressure switch hose for obstruction. If hose okay, change pressure switch.
Water level too high	Pressure Switch	Check for blockage in pressure switch hose. Check for pressure switch opening circuit across terminals. Replace switch if contacts do not open.
Water drains slowly	Drain System	Check hoses and drain valve for blockage. Clean of inadequate size. if necessary. Check building drains for blockage
Machine does not turn	VFD	Check VFD by removing inspection panel and record any numbers or letters displayed. If no display turn power off to machine at breaker for 2 minutes and turn power back on to reset. If still no display replace VFD
Machine tumbles in one direction	VFD	Remove inspection cover at rear and record in only numbers or letters displayed. See fault code section for more info.
	VFD	Inspect yellow enable wires from main relay PCB and at VFD
Excessive vibration	Mounting System	Check these areas: • Strength of mounting structure, concrete or base. • Mounting bolts may be loose and need tightening.
	Drive Belt	Worn drive belt can cause vibration and noise.
	Loading	Note: Small loads contribute to out of balance loading and increase vibration.
Machine does not spin	Pressure Switch	Check pressure switch for continuity across terminals #21 & #22 indicating pressure switch has reset to the empty position. If no continuity, change pressure switch.
Machine starts and does not operate	VFD	Check yellow enable wires from relay PCB P13 & motor P14 to VFD advances through cycle are connected. Check fault code on VFD before removing power from the drive. Check orange P-15 wire for signal from door switches.
Machine does not stop	Main PCB	Main PCB controls time cycle at end of cycle
	Braking Resistors	Check braking resistors for continuity. Verify ohms resistance by Molex.
Water leakage around loading door	Door Adjustment	Door may need adjustment due to abuse or wear. Check tightness around perimeter using a dollar bill. Adjust left to right tightness by shims at door lock or hinge side. It is important to center gasket to tub opening before tightening door to hinge bolts. Chalk may be used on tub front to show point of contact with tub. If gasket is deformed, worn, or damaged, replace. Refer to parts section for door gasket expander kit.

Troubleshooting Washer Fault Errors (F-Codes)

The following pages are a description of fault codes that will appear on the front of the washer. There is a chart format that shows what fault code that will be displayed at washer front. These codes displayed may stop machine operation or may not stop machine Please check chart before removing power to reset. PLEASE NOTE: CHECK DRIVE FAULT CODE BEFORE POWERING MACHINE DOWN!

Fault#	Description	Customer Action
F1	The door failed to close and lock or The door failed to remain locked during the cycle.	Check VFD fault code before turning off. Check to hear if door solenoid engaged. Turn off the power to the washer. Check wire connections to door /lock switches. Check wire connections from switches to controller. Check P-4 wire connections at PCB controller. Adjust the door lock mechanism. (See service manual)
F2	The washer tub does not fill with water within 7 minutes. The wash cycle will continue. The F 2 will flash three times, then wait for 30 seconds. The error will clear at the end of the cycle.	Turn off the power to the washer. Check the operation of the water valves. Check the incoming water pressure. Check for blocked or restricted water flow. Check to ensure the drain valve is functioning properly. This error will occur on 18# washers when water level is set for high (the pressure switch in 18# washer is only one level).
F3	Memory error in controller. The memory checksum is wrong.	Check VFD fault code before turning off power. Try to clear the fault with the Palm. Try a soft Reset of the controller with the white button. If problem. Replace PCB controller.
F4	Washer controller communication error	Check VFD fault code before turning off power. Try the data cable first. Move around cable and remove any side loading tension from data cable connector ends. Check connection P25/24/23 to P15. Turn power back on to the washer. If the problem returns, replace the PCB washer controller.
F5	Pressure Switch error (only OPL) - when the high level sensor indicates full but the lower one indicates empty. The wash cycle will continue. The F 5 will flash three times, then wait for 30 seconds. The error will clear at the end of the cycle.	Check VFD fault code before turning off power. Check the pressure switch.(Ohm out contacts). Check pressure switch connections to ensure they are all making good contact. Check the Molex type harness connector to ensure no wire been pushed out of the Molex type housing that it is shorting or not connecting.
F6	Wrong washer size for drive type.	Check VFD fault code before turning off power. If the controller was installed in a different size machine before being installed in this machine, a problem can occur. If someone has been doing repairs on the washer, check for the correct size drive. It can also be caused by pressure switch harness. Check to ensure the correct harness in installed. The control can be reset by holding program button on controller during startup (soft reset). Check orange wire at Molex connector on controller coming from pressure switch or replace pressure switch harness.

Fault#	Description	Customer Action
F7	Wrong size drive installed	Check VFD fault code before turning off power. Check to ensure all the harnesses are properly connected to the controller. Check to ensure the VFD drive horsepower is proper for this size of washer. The control can be reset by holding program button on controller during startup (soft reset) Check orange wires at molex connector on controller coming from pressure switch.
F8	The washer tub does not empty within 7 minutes. The wash cycle will continue. The F 8 will flash three times, then wait for 30 seconds. The error will clear at the end of the cycle.	Check VFD fault code before turning off power. Check to ensure the drain valve is operating properly (slow drain has potential to cause this code). Check to ensure the pressure switch tube is clear of any blockage, and the pressure switch is operating properly. Check the pressure switch harness.
F9	The washer tub does not reach the spin target frequency within 150 seconds. The wash cycle will continue. The F9 will flash three times, then wait for 30 seconds. The error will clear at the end of the cycle.	Check VFD fault code before turning off power. Check to ensure the drain valve is operating properly (slow drain has potential to cause this code). Check to ensure the pressure switch tube is clear of any blockage, and the pressure switch is operating properly. Check the pressure switch harness.
F10	After a spin the washer tub does not stop within 150 seconds.	Check VFD fault code before turning off power. Inspect the braking resistors and measure the resistance. Check connecting wiring from braking resistor to the drive mounted in the top of the washer. Reset the drive and try again. Possibly incorrectly programmed drive.
F11	The drive size setting has changed.	Check VFD fault code before turning off power. Check to ensure all the harnesses are properly connected to the controller. Check to ensure the drive horsepower is proper for this size of washer. If no one has worked on machine very recently then PCB controller or VFD may need to be replaced. Do a soft reset before and after either VFD replaced.
F12	Washer controller internal error	Check VFD fault code before turning off power. Turn off the power to the washer. Wait one to two minute. Turn on the power to the washer. If problem reappears, contact your Dexter Authorized Representative.
F13	The variable frequency drive (VFD) and the washer computer are not communicating.	Check the data communication cable between the washer computer and the variable frequency drive (VFD). Step 1: Make sure the cable did not become unplugged during operation. Step 2: Make sure that the cable is not being pulled sideways at either the washer controller, or the VFD, plug end. If both ends of the communications cable are plugged in the washer computer and VFD and there is no tension on the communications cable pulling it from side to side, then replace the cable.\n Step 3: Inspect both female connection points at PCB controller and at VFD. Blow out with compressed air and clean with contact cleaner. These may need replacement if they cannot be reset.

F14	Over-current on the drive or motor.	<p>Step 1: Check to make sure the washer cylinder turns freely by hand. If it turns freely, continue to step 2. If it does not, remove the belt and see if the motor turns freely by hand. If the motor turns freely, then check for obstructions in the cylinder or check the bearings. If the motor does not turn freely, replace the motor.</p> <p>Step 2: Check the motor wires for a short circuit between leads. If there are motor leads that have conductors touching, separate them and insulate them. If the wires are broken, splice them together or replace the motor.</p> <p>Step 3: Check braking resistors to see if they measure the correct resistance. If a resistor does not measure the proper value, replace it.</p>
F15	The variable frequency drive (VFD) senses that the internal voltage is too high. The source of the problem can originate from two different areas. Area 1: The input voltage can be too high, or there may be a high level of electrical noise. Area 2: The motor can be generating a voltage that is acting like an input to the VFD output motor terminals.	<p>Step 1: Measure the supply voltage to the VFD on the L1, L2 (or N), and L3 (if connected to three phase power). the supply voltage should be from 187 to 264 VAC or 108 to 132 VAC for a 120 VAC VFD. Also make sure the supply wires on L1, L2 (or N) and L3 (if connected to three phase power are securely connected.</p> <p>Step 2: Check the braking resistor connections at the VFD. The terminal screws should be tight. Once of the braking resistor wires should be connected to terminal B2.</p> <p>Step 3: Measure each braking resistor separately to make sure they are the correct resistance. (200 for 1 and 2 Hp VFD and 160 for 3 Hp VFD).</p> <p>Step 4: If you have a 240 VAC, high leg voltage supply, try disconnecting the high leg. If this cures the problem, either leave the high leg disconnected, connect a transient voltage surge suppressor (with some form of filtering) at the voltage supply panel, connect a line choke on the high leg or install a VFD filter.</p>
F16	The temperature sensor inside of the variable frequency drive detects that the internal temperature is too high.	<p>Step 1: Make sure the cooling fins on the VFD heatsink and the ventilation louvers on the VFD cooling fan cover are clean. Step 2: Start a washer cycle and make sure the VFD cooling fan operates after the cylinder starts turning.</p>
F17	Overload of the drive or motor	<p>(Check drive fault code before powering down). Check the washer motor to ensure it turns freely. Check the wiring for loose connections to the drive and motor. Measure the braking resistor values. Check for damaged motor wires. Check V-Belt tension and adjust to 1" deflection at center. Check braking resistors.</p>
F18	Ground Fault to the drive	<p>Check VFD fault code before turning off power. Check the wiring connections to the drive and motor. Check the ground wiring of the drive, motor and incoming connection to ensure a proper ground is present. Check for damaged motor wires.</p>

F19	Low Voltage to the drive	Check VFD fault code before turning off power. Turn the power off to the washer. Check the wiring connections to the drive and motor. If no problem is observed, turn on power to the washer and test. (See Note) Measure the incoming line voltage.
F20	Internal drive error	Check VFD fault code before turning off power. Turn the power off to the washer. Wait one minute. Turn the power on to the washer. If problem reappears, contact your Dexter representative.
F21	Data error on communications between the controller and drive Internal drive error # 32. This error also has CEXX errors associated with it that are presented on the drive display.	The CE errors are communications errors. Data Cable noise can cause the majority of these errors. Check VFD fault code before turning off power. Check the data cable between the controller and the drive. Replace data cable if it appears damaged and fault appears again. Please note that this fault will occur if you turned main power off and on to quickly. (See Note below)

Warning codes F22 - F28: These codes indicate that a component (VFD, relay PCB, injection relay PCB, water valve) has been replaced, added, or removed and you will need to soft reset the PCB controller board to reset the main controller to operate properly.

F22	MS300 Drive Conversion Only	Retighten the screw down connections on the lower terminal bar of the VFD for DC1, B1, and B2. Check the wire connections on B1 and B2 for Breaking Resistors.
F23	VFD has been replaced, disconnected, or removed.	Soft reset control.
F24	Injection relay PCB has been removed or loose connection.	Soft reset control.
F25	Optional water valve PCB removed or water valve has been replaced .	Soft reset control.
F26	VFD unit has been added or loose connection.	Soft reset control.

Fault#	Description	Customer Action
F27	Injection relay PCB has been added to machine or loose connection.	Soft reset control.
F28	Optional water valve PCB has been added or loose connection	Soft reset control.

Note: Whenever power is turned off to the washer, it must remain off for three minutes for drive to reset. The washer will not operate correctly if this is done improperly. This will allow most fault codes to reset that are displayed at washer front. A fault code F-13 or F-21 will appear on front display if this procedure has not been reset correctly. Note: Should a power loss occur during cycle and then power returns, P U S H will be displayed and customer must push a temperature selection button to continue the cycle.

Variable Frequency Drive Control

Digital Readout Faults

Description		Customer Action
CE1	VFD received an illegal command. Possible controller problem	Reset drive.
CE2	Illegal data address, VFD received an address not available to the controller.	Reset drive.
CE3	Illegal data value received at VFD. Possible controller problem.	Reset drive.
CE4	VFD unable to perform the requested action. Possible controller problem.	Reset drive.
CE6	Time frame between commands is too short. Possible controller problem.	Reset drive.
CE9	Internal checksum error. VFD problem.	Reset drive.
CE10	Watch dog timer. Command not received from the controller every 6 seconds	Reset drive.
CE11	Frame error. Possible Baud rate issues between VFD and controller	Reset drive.
CE12	Command message is too short. Possible controller problem	Reset drive.
CE13	Command message is too long. Possible controller problem	Reset drive.
CE14	Command message includes unused characters. Possible controller problem.	Reset drive.

Section 9:

Washer Electrical Wiring Diagrams & Schematics

Electrical Path Circuit Schematics

Start Circuit

Power travels into the machine on L1 & L2 & (L3, if 3 phase used). L1 and L2 provide 208- 240VAC to the controls transformer which steps the voltage down to 120VAC for the controls. (The L1 connection at the controls transformer must be checked at start-up to coincide with machine operating voltage) The 120VAC travels out from the transformer on either [X-1 red wire directly to the 1.5 amp fuse] or [X-1 black/red wire to TB-4 and then through the red wire to the 1.5 amp fuse]. The controls transformer also creates a neutral on the X-2 black/blue wire that connects to TB-1. From the fuse holder, 120VAC travels on the red wire to the #6 terminal on the terminal strip and then through the black wire to another step-down transformer. From the terminal strip the blue wire will provide the neutral for solenoid, thermoactuators and all valves. The white wire provides the neutral from the terminal to the step down transformer.

120VAC is stepped down to 2.3VAC (blue wires), 24VAC (red wires), and a yellow center tap wire to the P-7 power connection on the main controller PCB . With the main control PCB now powered, 5VDC will be present between the (2) yellow wires and also the (2) brown wires for the coin switches. Both pairs will now be ready to count coins through the P-2 connection at the control PCB. 26.8 VAC goes out on the black wire of the P-4 connection from the main control PCB to the S5 door closed switch which mounted on the hinge side of masking ring. Closing the door will engage the door closed switches, sending the voltage to the red wire on the S1 door latched switch. Turning the door handle to the vertical latched position closes the S1 door latched switch, returning the voltage to the main control PCB on the white/red wire at the P-4 connection. 26.8VAC is now present at the S2 and S3 door locked switches.

26.8VDC is also at the black and white wires between P-21 at the main control PCB and the P-20 of the relay PCB. This voltage signals the relay PCB that the door is closed and latched making 120VAC available to the relays controlling the door lock solenoid, drain valve and water valves. A continuous 5VDC is sent on the red wire from the P-1 connector on the main control PCB, through the (normally closed) emergency stop button switch and returns on the second red wire back to the P-1 connector. Payment is added and the display counts down on the main control PCB display until the vend price is satisfied. The display will change to read PUSH and the green light over the start button will flash. Pressing the start button on the front of the main control PCB signals the relay PCB to lock the door and 120VAC will go to the door lock solenoid on the white/red wire from the P17 connector of the relay PCB. The door lock solenoid engages and pulls up on the door locking rod, locking the door and closing the S2 and S3 door locking switches.

The S2 locking switch is a backup to the S1 latching switch so that once the cycle starts the S1 isn't critical. The S3 locking switch provides 26.8VDC on the orange wire back to P4 connector at the main control PCB and the P15 connector at the relay PCB. This signals that the loading door is closed,locked and safe to continue wash operations. This activates the P-13 and P-14 yellow enable wires to the inverter drive to allow motion. If there is no signal on P-15 (orange wire) there will be no motion of the tub. S1, S2, S3 and S5 door switches are now closed . The green On LED and the door lock solenoid (discussed in start circuit) will remain on throughout the cycle.

Fill Circuit-Warm

The relay PCB supplies 120VAC to the brown/yellow wire from P-17 to the drain valve which closes the valve. The lock thermoactuator also receives 120VAC on orange/blue from P17 of the relay PCB. This device prevents the door lock solenoid from dropping out and unlocking during the cycle in the event of a power loss. The 120VAC will cycle on and off keeping the lock thermoactuator engaged until 70 seconds before the end of the cycle. The main control PCB sends data commands to the VFD through the data cable connected at P-6. These commands control the wash basket which will tumble one direction for 12 seconds, pause, and then reverse direction for 12 seconds.

The prewash or wash LED will illuminate at this time, powered through the white wires from the P-3 con-

nection of the main control PCB to the LED printed circuit board. Using the factory preset cycle as an example: The washer fills the tub through the back of the machine with either one or both the C1 cold and H1 hot water valves. From the P19 connection of main relay PCB, 120VAC is sent out on the white/brown wire to the C1 cold water fill valve and the red/yellow wire to the H1 hot water fill valve depending on the temperature selected. After a 90 second delay from the beginning of the wash cycle bath only, the detergent dispenser flushes the detergent into the tub for 20 seconds. This is accomplished when 120VAC travels through the red/orange wire to the H2 hot water valve solenoid. During the machine fill, a 5VDC signal is sent on the red wire from the P5 connection of the main control PCB to the pressure switch contact and returns on the yellow and orange wires to the P5 connection of the main control PCB. When the water level in the basket reaches the preset level pressure, the switch moves the switch contacts to the full or open position. This causes the main control PCB to signal the relay PCB to shut off the water valve coils.

Wash Circuit

Once the machine has achieved it's water level, the wash basket will continue to tumble one direction for 12 seconds, pause, and then reverse direction for 12 seconds. The time on the front display will count down as the bath progresses. The time of the bath is programmable up 15 minutes per bath. Note: When programming cycles, the wash bath must be programmed for 3 minutes or more.

Drain

When the program bath time ends the main control PCB signals the relay PCB to remove 120 VAC power from brown/yellow wire at P17 going to the drain valve. The normally-open, spring-loaded drain valve opens allowing water to exit the machine. This resets the pressure switch back to an empty level and restores the 5VDC connection through the pressure switch from the red wires to the orange and yellow wires.

Rinse 1 & 2

For Rinse 1 & 2, the rinse LED will illuminate, the drain valve will receive 120VAC and close. The basket will fill and tumble the same as the wash bath for the programmed time. The rinse water temperatures are programmable and factory default is cold.

Final Rinse Circuit

The final rinse LED will illuminate, the drain valve will receive 120VAC and close. The basket will fill and tumble the same as the previous baths for the programmed time. The final rinse water temperatures are programmable. Note: When programming cycles, the final rinse bath must be programmed and cannot be set for less than 3 minutes. Also at the beginning of the final rinse bath, the main control PCB will signal the relay PCB to send 120V to the P-19 connector on the white/blue wire to the C2 cold water valve for 20 seconds to flush the fabric softener dispenser.

Spin Circuit

The spin LED will illuminate and the main control PCB sends a signal to the variable frequency drive via the data cable at P6 to VFD RJ-11. The rotation as viewed from front during spin will be counter-clockwise. (The 18lb washers will extract in a clockwise direction) The time of the spin cycle can be programmed. Note: The final spin must be programmed into the final rinse bath and must be programmed for 1 minute or more.

Unlock Thermoactuator and Shake Out Circuit

70 seconds before the end of the cycle the main control PCB signals the relay PCB to remove 120VAC from the orange/blue wire at the P-17 connector on the lock thermoactuator. This allows the lock thermoactuator time to cool and retract by the end of the cycle. To insure that the lock thermoactuator has retracted by the end of the cycle, 1 minute prior the end of the cycle, the unlock thermoactuator is powered with 120VAC through the orange/red wire from the P-17 connector of relay PCB. The unlock thermoactuator moves the complete bracket assembly away from the door lock solenoid allowing it to drop at the end of the cycle. The basket will come to a stop from spin speed with the assistance of dynamic braking resistors wired to the variable frequency drive. (See wiring diagrams for quantities and resistor ohm values). The washer will then tumble for 45 seconds to let the clothes shake loose from the basket and then stop.

End of Cycle and Door Open Circuit

Once the machine stopped, 3 things occur: 1. The beeper will signal for 5 seconds letting the user know that it is the end of the cycle. 2. The main control PCB signals the relay PCB to remove power from the white/red wire at P-17 which allows the door lock solenoid to unlock. 3. The main control PCB resets when the S1,S2,S3,S5 switches open and door is opened. The machine is now ready to accept coins again.

Drive Motor Inverter Type Motor-Winding Resistance Chart

30lb A-Series Washer

Motor	Winding	Wire #	Resistance	
			Minimum	Maximum
30lb 1ph or 3ph 60hz	Main (wash & spin)	T1 & T2	2.45	2.71
Dexter #9376-305-001		T2 & T3	2.45	2.71
A.O. Smith #19343600		T1 & T3	2.45	2.71

NOTE: Resistance values are measured at the stator. Values at the end of the motor wiring harness may be slightly higher.

Wiring Schematic for 60hz Coin Washer

208-240V-3PH OR 1PH-60HZ

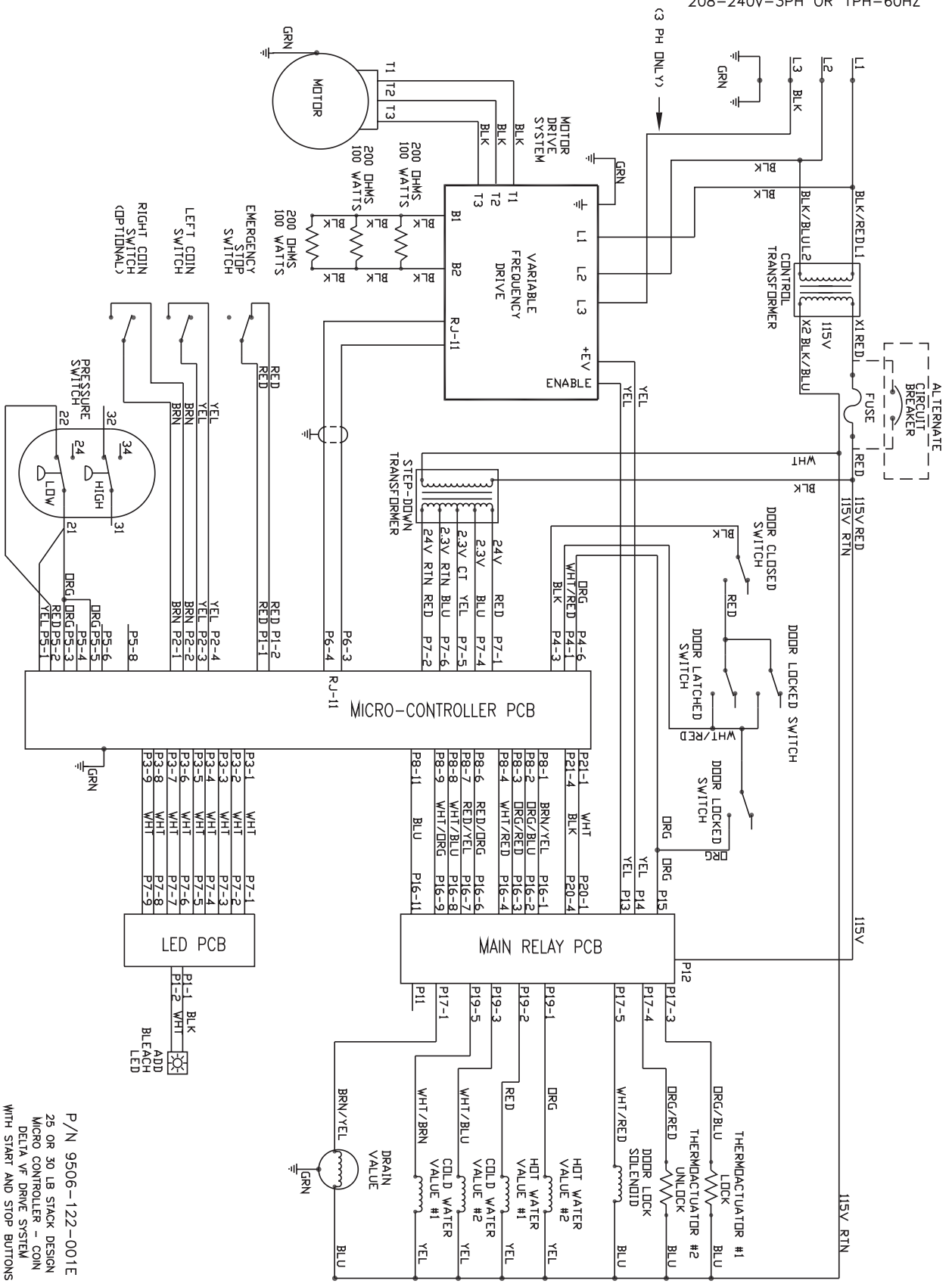

Wiring Diagram for 60hz Coin Washer

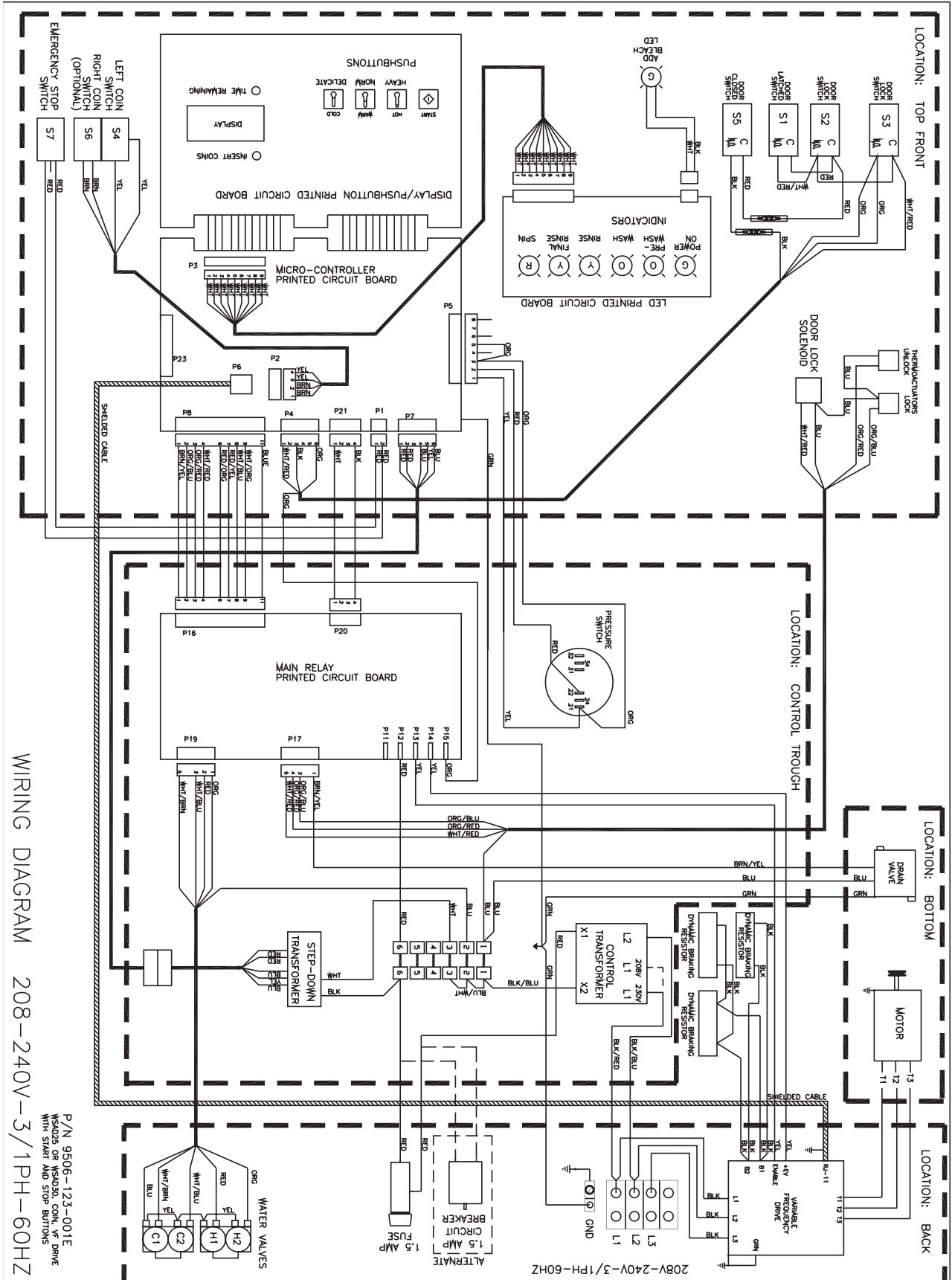

WIRING DIAGRAM 208-240V-3/1PH-60HZ

P/N 9506-123-001E
 MAINS OR MOTOR DRIVE
 WITH START AND STOP BUTTONS

Wiring Diagram for 60hz Easy Card Washer

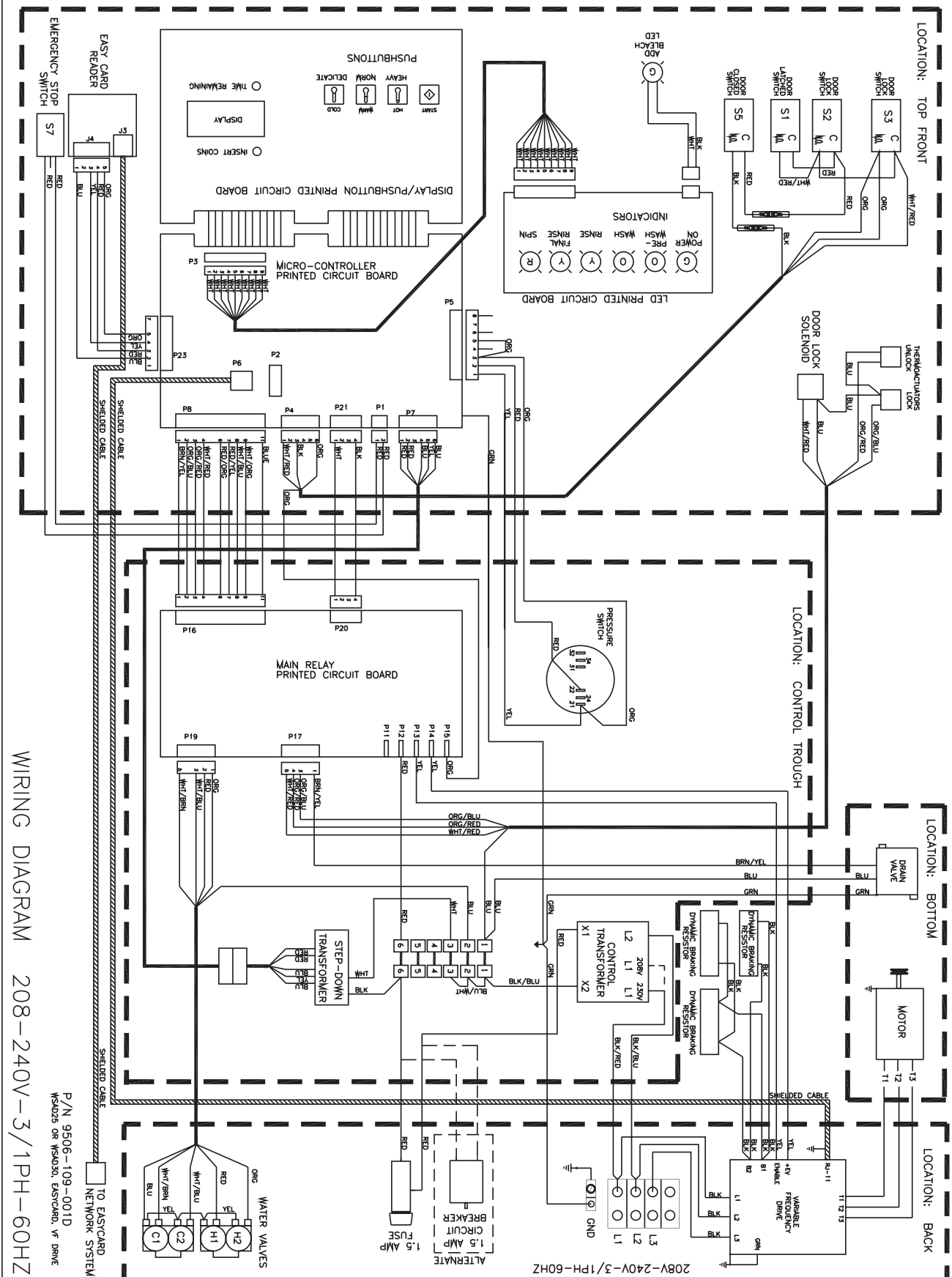

SWD A-Series Accessories

Key	Description	Part Number	Qty
*	Mounting Base 4"	9945-110-001	1
*	Mounting Base 6"	9945-111-001	1
*	Bevel Washer for 5/8" bolt used in installations using angle iron bases	8641-586-002	4
*	Bevel Washer for 3/4" bolt used in installations using angle iron bases	8641-586-003	4
*	Kit, Door Gasket Expander (large)	9732-139-002	1
*	Kit, Door Gasket Expander (small)	9732-139-001	1
*	Hose, Water Supply 3/8" I.D. x 48"	9990-027-011	2
*	Washer, Inlet Hose (furnished)	8641-242-000	1
*	Strainer, Inlet Hose (furnished)	9565-003-001	1
*	Sealing compound	8538-151-001	1
*	TORX#20	8545-051-002	1
*	Special Tool For Removing Coin Acceptor Mounting Screws. (T-10 Torx)	8545-051-003	1
*	Flow Restrictors (in dispenser)	9475-002-003	3
*	Battery 3V Lithium (used on Control PCB)	8612-001-001	1
*	VFD Filter options (3 phase)	9732-231-001	1
*	VFD Filter options (1 phase)	9732-232-001	1
*	Coin Bearing & Seal Kit	9732-219-004	1
*	Mode Light Support	9635-022-001	1
*	A to C Series Kit Blue	9732-312-003	*
*	A to C Series Kit Black	9732-312-004	*

Kits, Assemblies, & Common Parts

Description	Model
Coin Switch	9539-466-005
Coin Switch - Small terminals	9539-497-001
Kit - 8650-012-003 Lock with spacer	9732-344-001
Kit, Replacement for 9375-015-014	9732-345-033
Kit, 3" Drain Valve Replacement	9732-327-001
Drain Valve 3"	9379-202-001
Water Valve (Dual)	9379-183-012
Diaphragm	9118-049-003
Cylinder Plug (1.5" Plastic)	9456-041-007
Electronic Pressure Switch	9732-315-001
Breaking Resistor 200 Ohms	9483-004-002
Transformer, Main	8711-004-001
Transformer, Control	8711-010-001
Main Control Board	9473-009-008
Data Cable	9806-015-002
Door Lock Gear Motor Assembly	9985-011-009
Door Lock Latching Assembly	9885-024-001
Door Handle Only (Small)	9244-080-003
Door Switch	9539-492-001
Optical Coin Acceptor	9021-092-002
Coin Drop Screws	9545-053-002 x4
Retainer Coin Acceptor	9486-145-001
5/16 Hex Screw	9545-008-026
Belt	9040-077-003 x2
Top Lock Key #6324	9306-025-001
Fuse	8636-018-001
Fuseholder	9200-001-002
Door Glass Gasket	9206-419-001

Section 10:

Washer Parts

WSAD Wiring Harnesses Parts

Key	Description	Part Number	Qty
1	Add Bleech Light, (Wiring Harness included)	9794-001-001	1
2	Wiring Harness, Door Lock P15/P4	9627-816-002	1
3	Wiring Harness, CoinDrop Mech	9627-817-001	1
4	Wiring Harness, Drain,Thermo,DoorSol P17	9627-820-001	1
5	Data Cable	9806-015-002	1
6	Wiring Harness P20/P21	9627-818-001	1
7	Wiring Harness P8/P16	9627-819-001	1
8	Wiring Harness WaterValve/P19	9627-795-004	1
9	Wiring Harness LED PCB	9627-821-001	1
*	Wire Yellow Jumper (water valve)	8220-123-001	1
*	Harness Power Terminal Block	9627-747-002	1
10	Harness-Extention, Transformer	9627-826-001	1
12	Harness-P5/Pressure Switch	9627-822-001	1
*	Fuse-1.5a	8636-018-001	1
*	Fuseholder-Assembly	9200-001-002	1
*	Circuit Breaker (optional) 1.5 AMP	5198-211-004	1
*	Wiringlabel-schematic	9506-122-001	1
*	Wiringlabel-diagram	9506-123-001	1

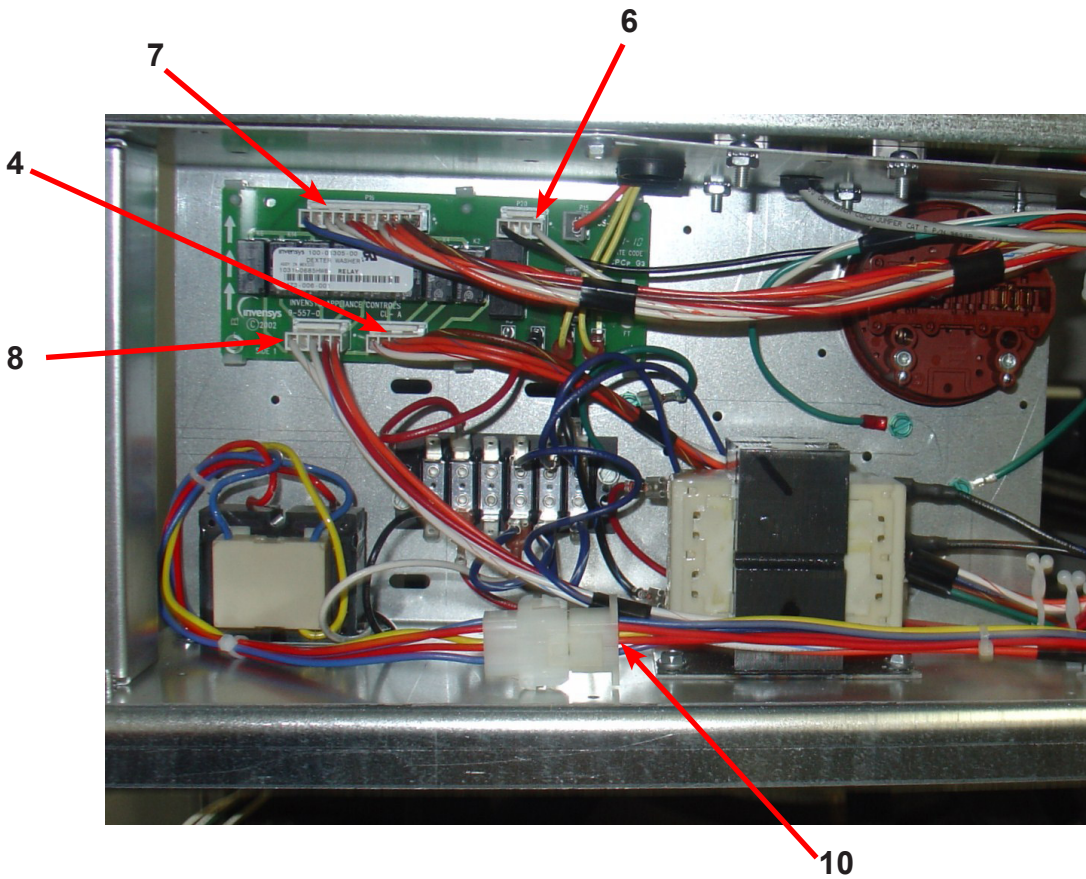
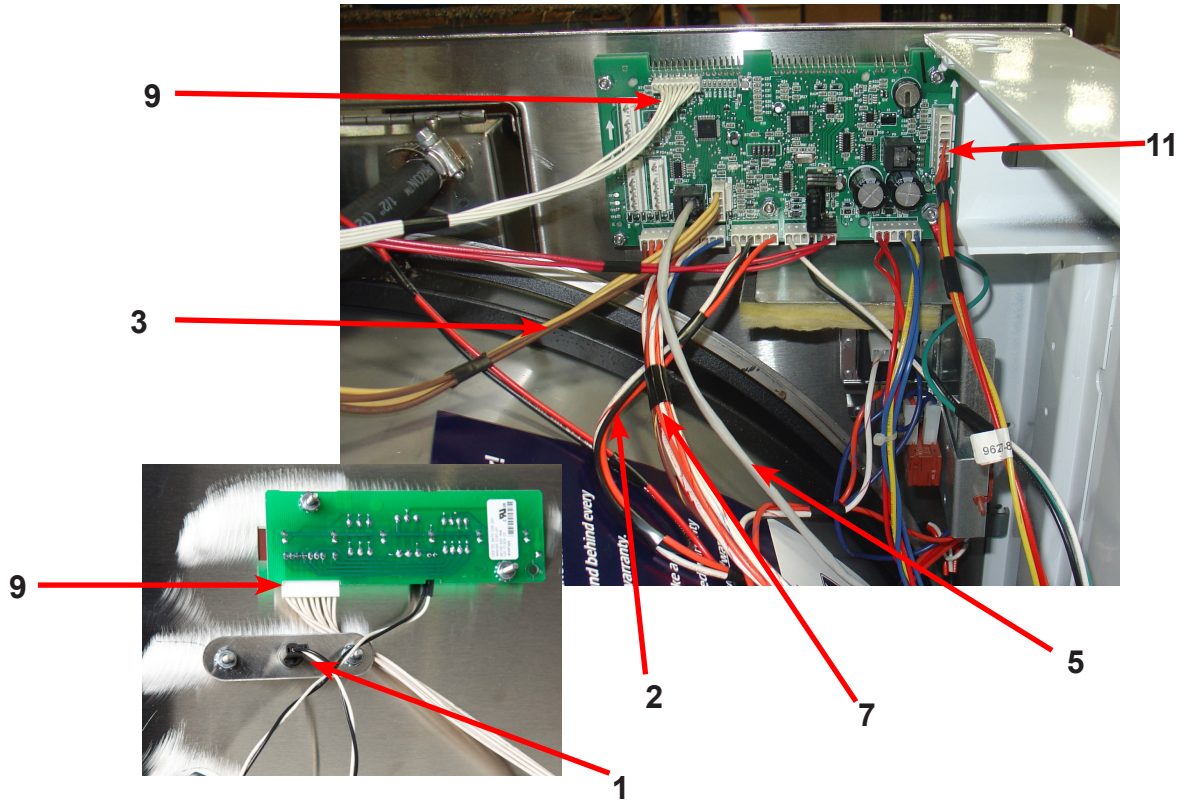

WSAD Rear View Access Parts Group Part

Key	Description	Part Number	Qty
1	Drive Motor, 3 Phase (Inverter duty)	9376-319-001	1
2	Rod, Motor Mtg	9497-222-006	1
*	Collar, Shaft (w/set screws) Before Serial # 530726	9076-052-002	2
*	Motor Bushing (plastic) Before Serial # 530726	9053-074-002	2
3	Motor Bushing (Rubber) after Serial #530726	9053-082-001	2
*	Clamp-Worm, 316SS, 1.5" (for Rubber bushing)	8654-117-019	2
4	Strap Bracket, Motor Tension (After Serial # 525645)	9029-206-002	1
*	Nut, Strap to Motor (After Serial # 525645)	8640-413-002	1
*	Strap Bracket, Motor Tension (Before Serial # 525645)	9029-027-005	1
*	Nut, Strap to Motor (Before Serial # 525645)	8640-414-003	1
*	Washer (Before Serial # 525645)	8641-581-006	1
5	Spring, Belt Tension	9534-319-002	1
*	Bolt, Eye (1/4"-20x1/2")	9545-055-002	1
*	Nut, 1/4 Elastic Stop	8640-414-003	1
*	Pulley, Motor	9453-170-003	1
*	Set Screw,Sq.Hd(motor pulley)	9545-028-015	2
*	Tolerance Ring	9487-234-003	1
6	Pulley, Driven	9453-168-003	1
*	Screw 5/8-11x1/2"	9545-060-001	1
*	Lockwasher 5/8"	8641-582-018	1
*	Washer, Flat 5/8x2 1/4"	8641-581-032	2
7	Drive Belt	9040-077-003	2
8	Channel, Rear	9081-131-001	1
*	Screw	9545-008-026	4
*	Nut, Spring	8640-399-007	4
*	Hose, Overflow to drain	9242-449-004	1
*	Clamp, Hose overflow to drain	8654-117-009	2
9	Hose, Overflow Vent Top	9242-463-005	1
*	Clamp, Hose Vent	8654-117-014	1
10	Vaccum Breaker ALL	9610-001-001	1
11	Bracket, Vacume Breaker	9029-121-001	1
12	Screw, 10B x 1/2	9545-008-026	4
13	Hose, Vacuum Breaker to tub	9242-458-001	1
*	Plastic Plug 7/8" Electrical Connection	9456-041-006	1
*	Panel Assy., Back	9454-714-001	1
*	Screw Panel Mtg.#10Bx1/2"	9545-008-026	10
*	Screw Panel Mtg.#10Bx1/2"	9545-030-002	3
*	Nut, Spring	8640-399-004	8
14	Hose, Pressure Switch	9242-175-005	1
*	Clamp, Pressure Switch Hose	8654-117-015	1
15	VFD Delta "S" drive 208-240 volt	9375-015-014	1
16	Braking resistors (200 ohm)	9483-004-002	3
17	Bracket assembly (drive mounting)	9985-176-001	1

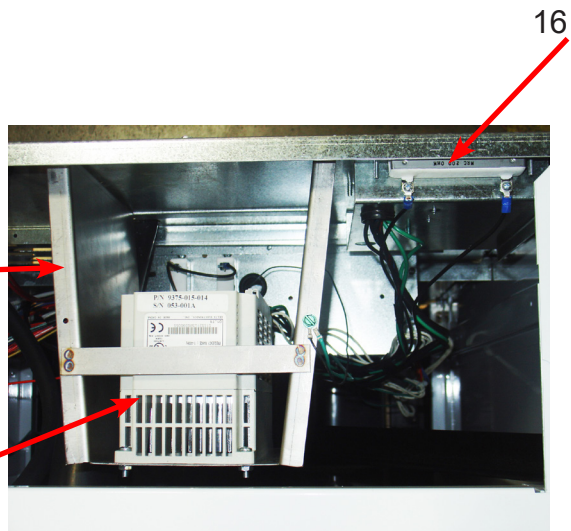
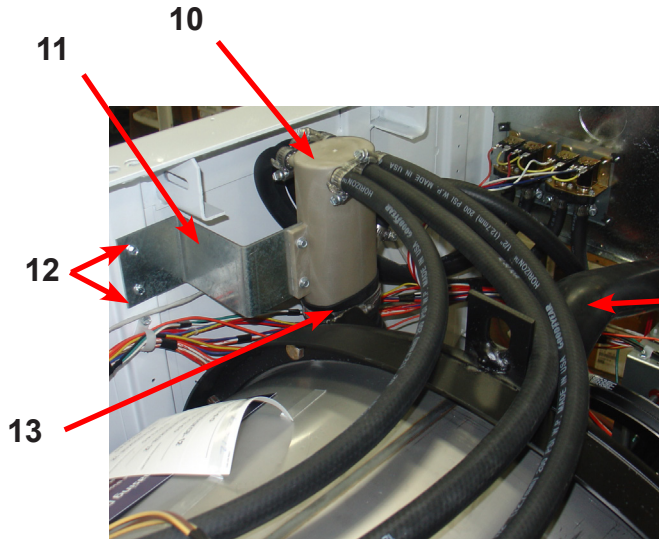
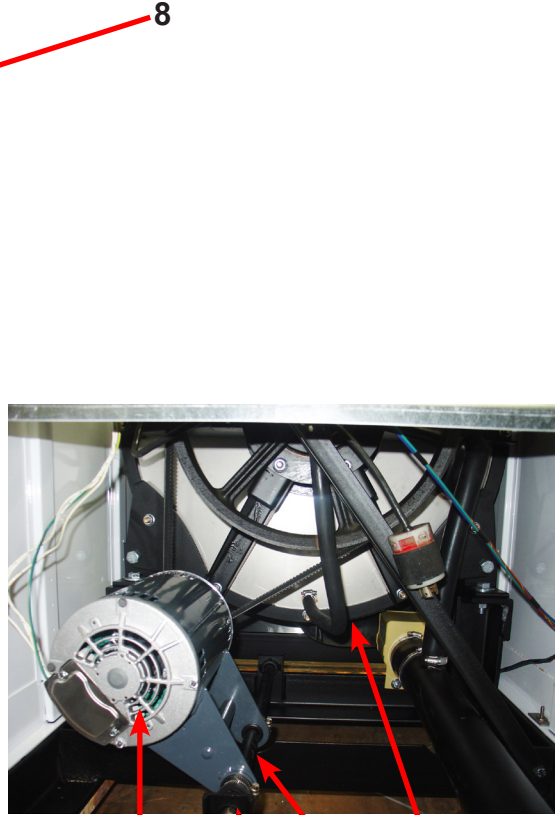
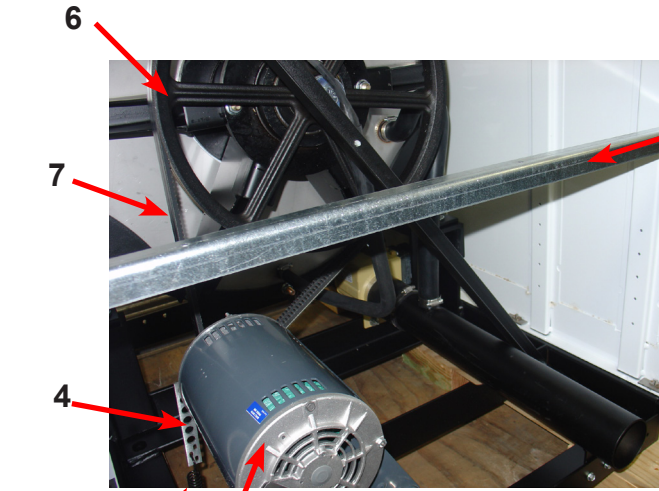

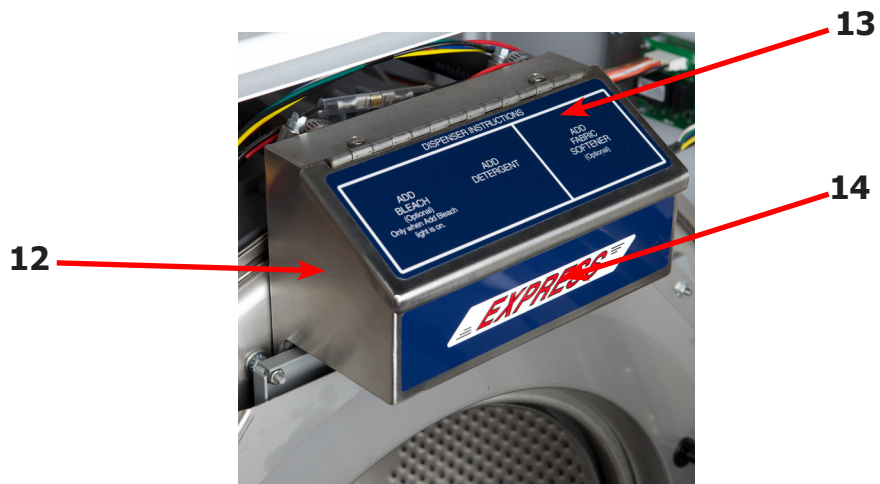
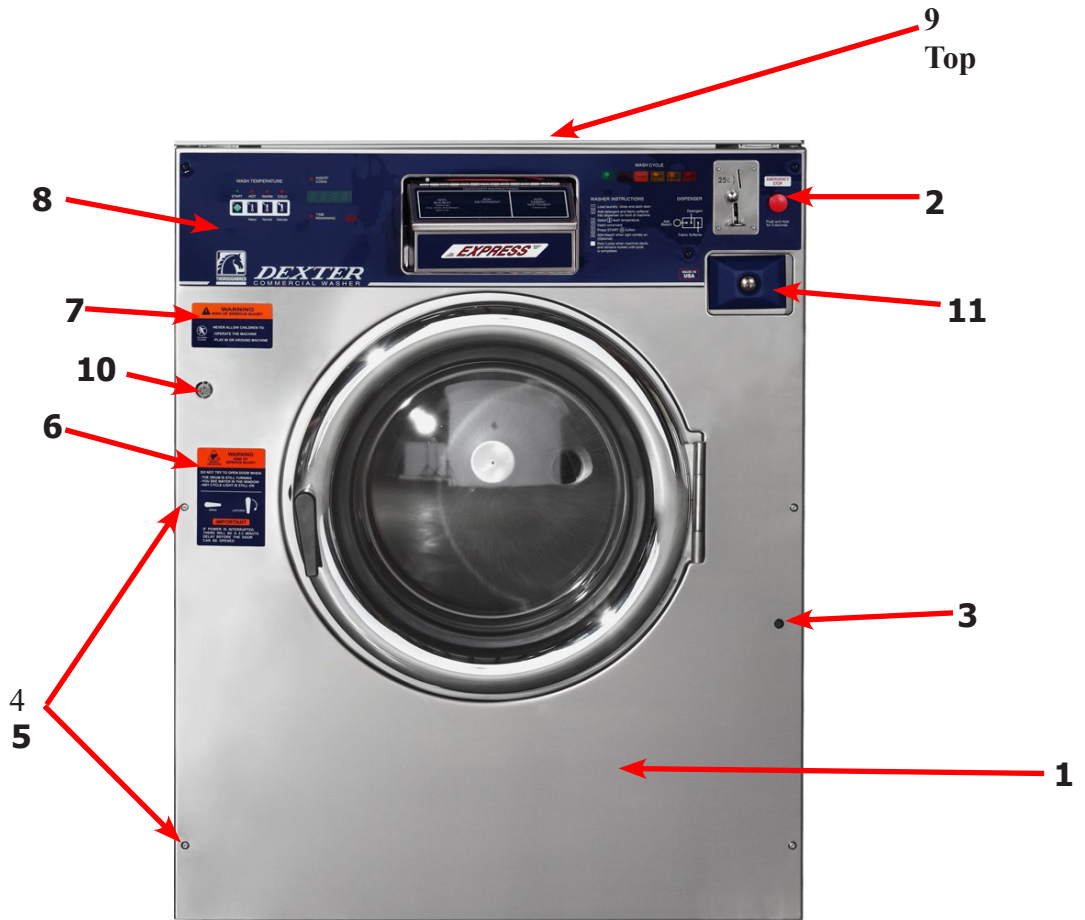

WSAD Cabinet and Front Panel Group Before Serial # 554488

Key	Description	Part Number	Qty
*	Panel, Right Side-Painted	9989-493-002	1
*	Panel, Left Side - Painted	9989-494-002	1
*	Bracket, Side Panel under front panel	9982-318-001	8
*	Screw	9545-018-023	8
1	Panel Assy, Front	9989-505-001	1
2	Switch Assembly, Stop Button Mounting Kit	9732-223-002	1
*	Stop Button Mounting Plate	9452-725-001	1
3	Bumper Loading Door	9051-053-001	1
4	Screw, Flat Head- Front to Sides	9545-008-020	4
5	Washer, Finish	8641-582-019	4
*	Nut, Spring-To Front Panel	8640-442-001	4
6	Label, Door Opening	8502-723-001	1
7	Label, Risk of Injury	8502-722-002	1
8	Nameplate Decal, Control Panel	9412-143-001	1
9	Panel Top, Front, Painted	9989-470-002	1
*	Screw, Hex, #10B x 1/2	9545-008-026	8
*	Panel Top Rear	9454-717-001	1
*	Screw, Hex, #10B x 1/2	9545-008-026	6
10	Lock, Top (w/Key)	8650-012-003	2
*	Key, Top- # 6324	6292-006-007	1
*	Cam, Lock-Top	9095-042-001	2
*	Nut, 9/32 - 28 Hex	8640-426-001	2
*	Washer Flat 5/16	8641-581-008	2
*	SS Coin Vault Assy, Coin	9942-028-003	1
11	Coin Box, Blue	9807-099-001	1
12	Soap Dispenser Assembly, Complete (Does not include lid)	9807-087-001	1
*	Soap Box mounting Gasket	9206-422-001	1
13	Lid Assembly soap box	9987-104-001	1
*	Lid screws #10-32x1/2 SS	9545-012-017	2
*	Nut Hex Elasticstop #10-32 SS	8640-413-006	6
*	Bracket Soap box mounting	9029-122-002	1
*	Softner siphon tube (plastic)	9574-252-002	1
*	Flow restrictors	9475-002-003	3
14	Label "EXPRESS" , Soap Dispenser	8502-715-001	1



WSAD Cabinet and Front Panel Group After Serial #554488

Key	Description	Part Number	Qty
*	Panel, Right Side-Painted	9989-493-002	1
*	Panel, Left Side - Painted	9989-494-002	1
*	Bracket, Side Panel under front panel	9982-318-001	8
*	Screw	9545-018-023	8
1	Panel Assy, Front	9989-551-001	1
2	Switch Assembly, Stop Button Mounting Kit	9732-223-002	1
*	Stop Button Mounting Plate	9452-725-001	1
3	Bumper Loading Door	9051-053-001	1
4	Screw, Torx Head- 10AB x 3/4,	9545-008-020	4
*	Nut, Spring-To Front Panel	8640-399-001	4
5	Label, Door Opening, Blue	8502-723-001	1
5	Label, Door Opening, Black	8502-742-001	1
6	Label, Risk of Injury, Blue	8502-722-002	1
6	Label, Risk of Injury, Black	8502-741-001	1
7	Nameplate Decal, Control Panel, Blue	9412-143-001	1
7	Nameplate Decal, Control Panel, Black	9412-203-001	1
8	Button, Push Control, Blue	9035-062-001	1
8	Button, Push Control, Black	9035-062-002	1
9	Screw, Torx Head- 10AB x 3/4, Blue	9545-008-009	2
9	Screw, Torx Head- 10AB x 3/4, Black	9545-008-036	2
10	Panel Top, Front, Painted	9989-470-002	1
*	Screw, Hex, #10B x 1/2	9545-008-026	8
*	Panel Top Rear	9454-717-001	1
*	Screw, Hex, #10B x 1/2	9545-008-026	6
11	Lock, Top (w/Key)	8650-012-003	2
*	Key, Top- # 6324	6292-006-007	1
*	Cam, Lock-Top	9095-042-001	2
*	Nut, 9/32 - 28 Hex	8640-426-001	2
*	Washer Flat 5/16	8641-581-008	2
*	Coin Vault Assy, Coin	9942-028-003	1
12	Coin Box, Blue	9807-099-001	1
12	Coin Box, Black	9807-099-003	
13	Soap Dispenser Assembly, Complete (Does not include lid)	9807-087-001	1
*	Soap Box mounting Gasket	9206-422-001	1
14	Lid Assembly soap box	9987-104-001	1
*	Lid screws #10-32x1/2 SS	9545-012-017	2
*	Nut Hex Elasticstop #10-32 SS	8640-413-006	6
*	Bracket Soap box mounting	9029-122-002	1
*	Softner siphon tube (plastic)	9574-252-002	1
*	Flow restrictors	9475-002-003	3
15	Label, Dispenser Instructions, Blue	8502-678-001	1
15	Label, Dispenser Instructions, Black	8502-745-001	1
16	Label "EXPRESS", Soap Dispenser, Blue	8502-715-001	1
17	Door, Lower Service Assembly (w/handle)	9960-286-006	1
18	Handle, Lower Service Door	9244-086-005	1
19	Screw, Torx Head- 10AB x 3/4,	9545-008-020	4

WSAD Cylinder, Seals & Bearings Parts

	Description	Part Number	Qty
*	Bearing and Seal Kit	9732-219-005	1
*	Housing, Bearing- Assembly (items #2-#6)	9803-186-001	1
2	Housing, Bearing	9241-180-002	1
3	Bearing, Front (LARGE)	9036-159-005	1
4	Bearing, Rear (SMALL)	9036-159-004	1
5	Spacer, Bearing	9538-167-001	1
6	Ring, Bearing Retainer	9487-238-003	1
8	Seal, Small	9532-140-002	1
9	Seal, Large	9532-140-006	1
10	Ring, Seal Mounting	9950-048-001	1
11	Tub Back Mating Ring	9487-261-003	1
12	Bolt 5/8-11x1 1/2" Tub end of bearing Housing	9545-060-001	6
12	Nut 5/8"-11	8640-425-001	6
13	Support Arm Assy, Bearing Housing	9991-056-002	6
14	Bolt Pulley end of bearing housing, 7/16-14x2"	9545-059-003	6
*	Nut, Flange Locking 7/16"	8640-416-005	6
15	Pulley, Driven	9453-168-003	1
16	Ring, Tolerance	9487-234-003	1
17	Washer 5/8"x 2 1/4"	8641-581-032	2
18	Bolt 5/8-11x1 1/2"	9545-060-001	1
19	Lockwasher 5/8 Ext. tooth	8641-582-018	1
*	Cylinder Assy	9732-354-005	1
*	Tub and Cylinder Assy.	9869-011-002	1
*	Plastic Plug 1 1/2"-(inside cylinder)	9456-041-007	1

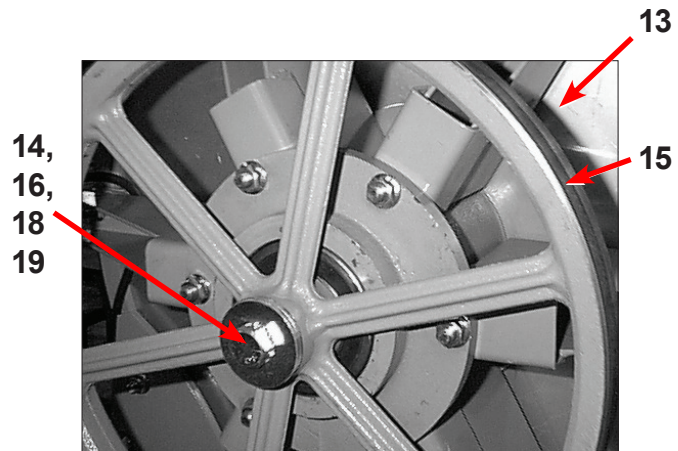
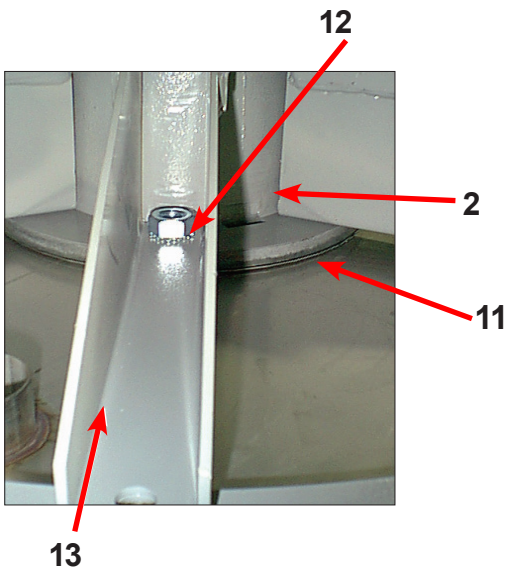
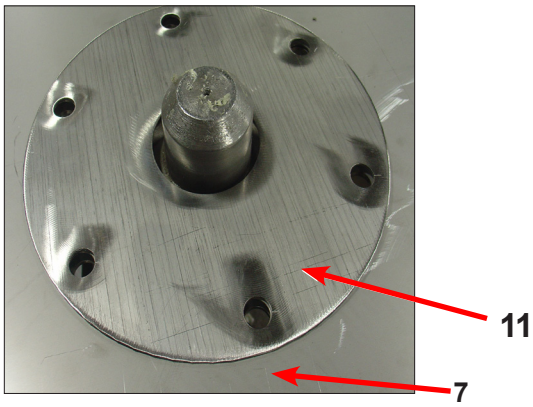
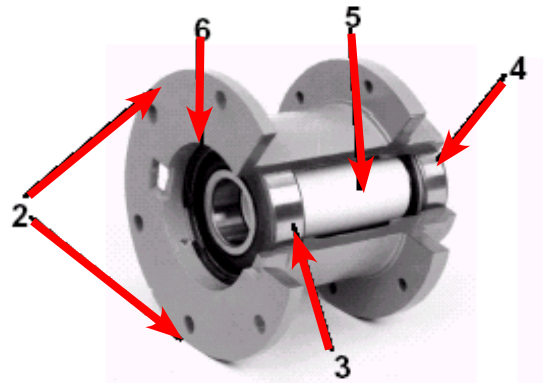
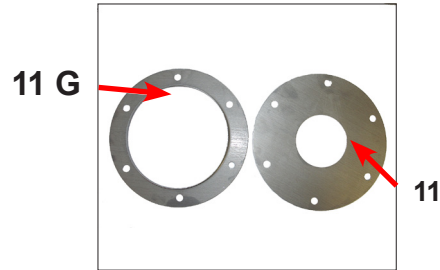
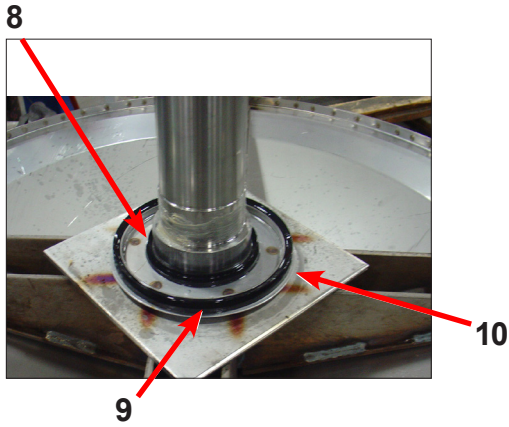
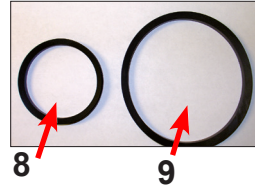
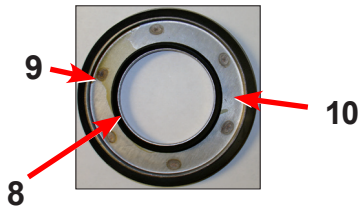

Door Lock Assembly (continued)

Key	Description	Part Number	Qty
33	Lock Assy, Complete (#1-22)(includes #1 thru #22)	9885-024-001	1
1	Plate Assy, Door Lock	9982-346-001	1
2	Washer, Flat	8641-581-030	1
3	Actuator, Latching Switch	9008-005-001	1
4	Pawl, Locking	9732-346-002	1
5	Washer, Spring	8641-569-003	1
6	Ring, Retaining	9487-200-004	1
7	Bracket Switch	9029-163-001	1
8	Nut, Hex 10-32 UNF	8640-413-002	2
9	Spring, Actuating	9534-364-002	1
10	Screw, Hx. 10-32 x 1"	9545-012-020	1
11	Nut, Elastic Stop 10-32	8640-413-004	2
12	Spring, Return	9534-364-001	2
13	Pin, Guide	9451-193-001	1
14	Ring, Retaining	9487-200-005	1
15	Washer	8641-581-031	1
16	Switch, Latching Sensing	9539-461-008	1
17	Shield, Switch	9550-169-003	3
18	Screw 4-40 x 5/8"	9545-020-001	2
18	Nut, Twin 4-40	8640-401-001	1
19	Switch, Locking Sensing	9539-461-007	2
20	Actuator, Switch Locking	9008-006-003	1
21	Screw 4-40 x 1 1/8"	9545-020-003	2
21	Nut, Twin 4-40	8640-401-001	1
*	Spacer Sensor	9538-182-001	*
*	Shim, Door Lock, Thin	9552-037-001	AR
*	Screw, Lock mtg 1/4"-20 x 3/4"	9545-018-014	3
*	Lockwasher 1/4" Ext tooth	8641-582-007	3

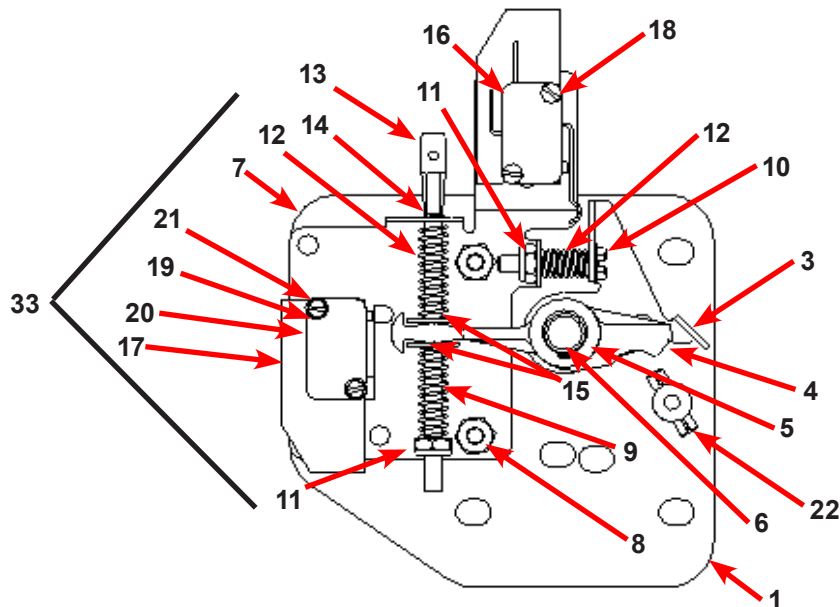

WSAD Door Lock Solenoid Assembly

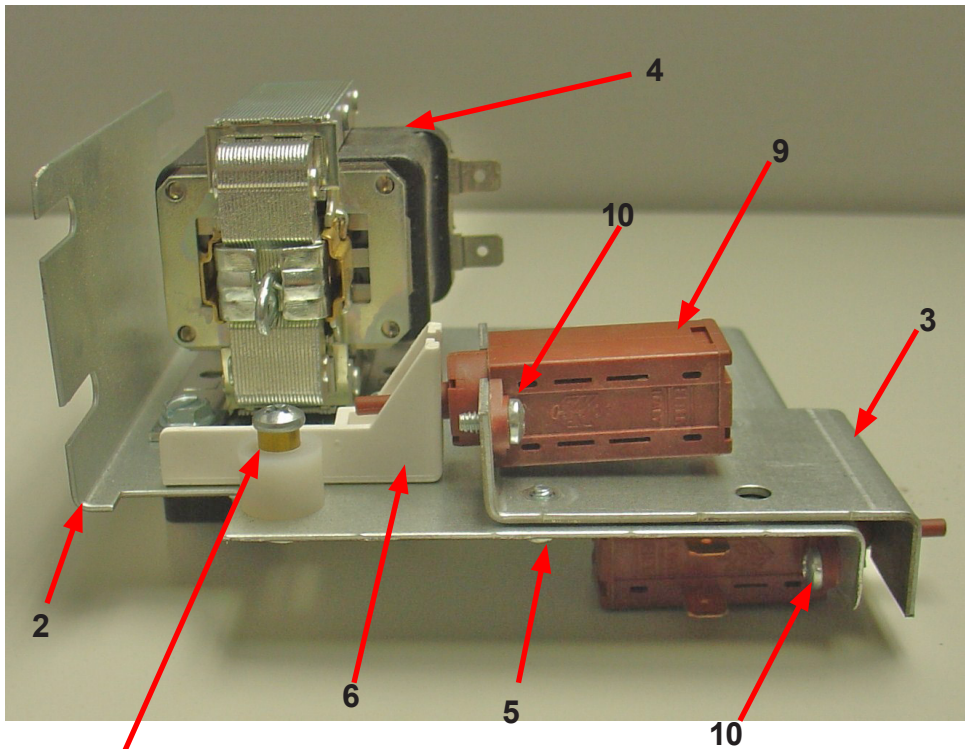

11, 12, 13

Key	Description	Part Number	Qty
1	Solenoid Ass'y, Door Locking (includes 23 thru 32)	9985-011-009	1
2	Bracket, (Door Locking Solenoid)	9985-169-001	1
4	Solenoid 120V 60 hz	9536-082-002	1
5	Screw, Solenoid Mtg	9545-008-001	3
6	Stop, Door Lock Solenoid	9540-036-001	1
7	Screw, Shoulder	9545-061-001	1
*	Nut, Keps #6	8640-411-002	1
9	Thermoactuator 120 V	9586-001-001	2
10	Screw #6 x 5/16"	9545-031-011	4
11	Spacer, Plastic	9538-157-004	1
12	Spacer, Metal	9538-166-004	1
13	Screw, Cross Recessed	9545-010-001	1
14	Nut, Keps #8	8640-412-005	1
*	Rod, Pull	9497-225-008	1
*	Nut, Sol. Brkt. to Control Panel	8640-412-005	3
*	Gear Motor Locking Kit	9732-283-003	*

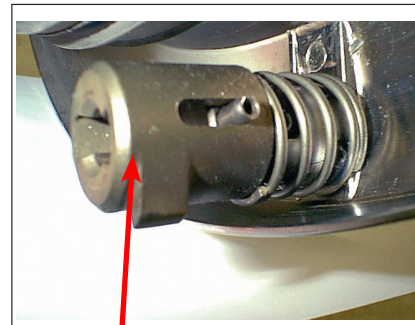
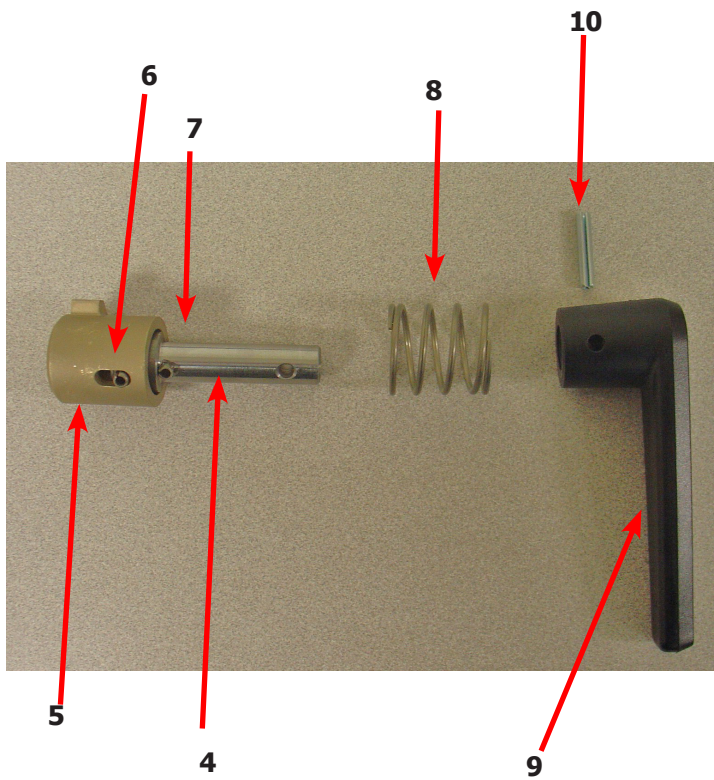
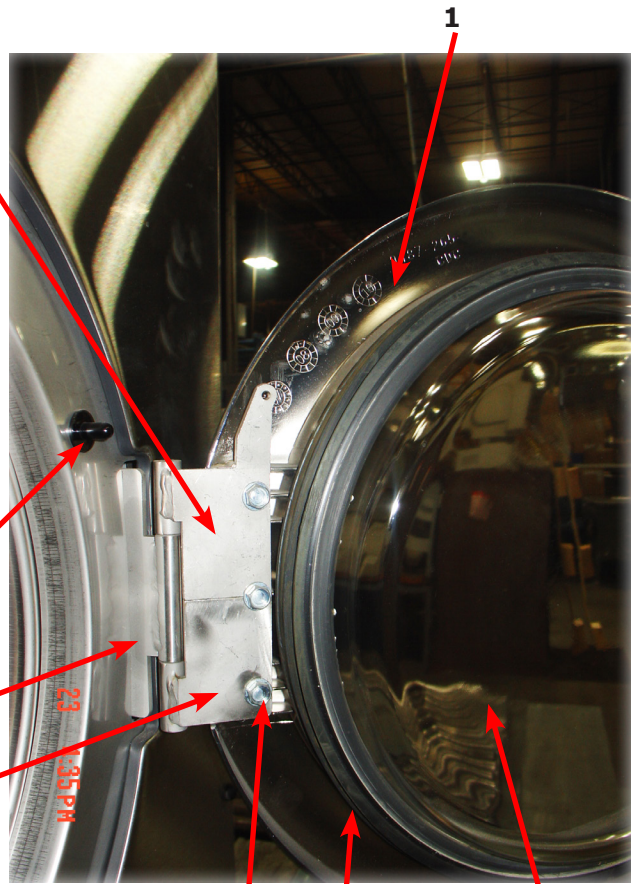
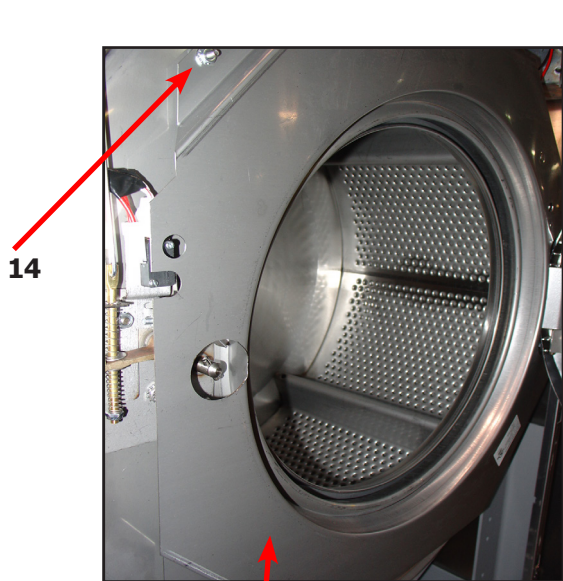

WSAD Loading Door Group Parts

Key	Description	Part Number	Qty
	Loading Door, Complete #1-10	9960-274-004	1
1	Loading Door, Ring (180 Degreese)	9487-265-002	1
2	Gasket, Loading Door	9206-419-001	1
3	Window, Loading Door	9635-016-001	1
*	Shaft Assy, Locking (includes 4 thru 7)	9913-134-003	1
4	Shaft, Door Locking	9537-195-002	1
5	Cam, Locking	9095-040-002	1
6	Pin, Groove (1 1/4)	9451-181-005	1
7	Pin, Groove (3/4)	9451-181-004	1
8	Spring, Lock Cam	9534-360-002	1
9	Handle, Door	9244-080-003	1
10	Pin, Door Handle (groove)	9451-181-006	1
11	Screw, Loading Door Mtg (5/16" TF)	9545-056-002	3
*	Shim, Loading Door Hinge, Thin	9552-037-001	1
12	Door Hinge Assembly Mounts to Tub Front	9550-030-001	1
*	Screw, Hinge Mtg 5/16" -18x 3/4"	9545-014-009	3
*	Lockwasher 5/16" Ext tooth	8641-582-009	3
*	Wiring Harness doorlock safety Switch Assembly	9627-816-002	1
*	Wire Assembly Door Close Switch, Red 17"	8220-063-025	1
*	Wire Assembly Door Close Switch, BLK 17"	8220-063-026	1
13	Leaf assembly, Hinge Top (Push Button Style)	9545-005-004	1
14	Leaf assembly, Hinge Bottom	9545-005-002	1
15	Masking Ring (push Button SwitchStyle)	9487-273-002	1
16	Switch, Door closed Switch (Push Button style)	9539-492-001	1
*	Masking Ring (Micro Switch Style)	9950-060-002	1
*	Leaf assembly, Hinge Top (Micro Switch Style)	9845-005-003	1
*	Switch Assembly, Door Closed (Micro Switch Style)	9801-089-001	1
*	Box, Door Switch	9041-087-001	1
*	Bushing-Insulating, Plastic	9053-067-003	1
*	Switch, Micro	9539-461-007	1
*	Shield-Door Switch	9550-159-001	1
*	Nut-Special Twin #4-40	8640-401-001	1
*	Screw, #4-40 x 5/8	9545-020-001	2
*	Wire Assembly, BLK 17"	8220-062-028	1
*	Wire Assembly, RED 17"	8220-062-027	1
*	Actuator, Door Switch	9008-004-001	1

WSAD Loading Door Hinge Parts Group

With Pin (Before Serial # 507538)

Key	Description	Part Number	Qty
*	Loading Door, Complete #1-10	9960-274-004	1
1	Loading Door, Ring	9487-265-002	1
2	Gasket, Loading Door	9206-419-001	1
*	Window, Loading Door	9635-016-001	1
*	Shaft Assy, Locking (includes 3 thru 6)	9913-134-003	1
3	Shaft, Door Locking	9537-195-002	1
4	Cam, Locking	9095-040-002	1
5	Roll Pin Type, Groove (1 1/4)	9451-181-005	1
6	Roll Pin Type, Groove (3/4)	9451-181-004	1
7	Spring, Lock Cam	9534-360-002	1
8	Handle, Door	9244-080-003	11
9	Roll Pin Type, Door Handle (groove)	9451-181-006	
12	Door Hinge (mounts to tub)	9950-030-001	1
*	Screw, 5/16-18 x 3/4	9545-014-009	3
*	LockWasher-External tooth, 5/16	8641-582-009	3
13	Top Door Hinge Leaf with switch pin	9845-005-003	1
14	Bottom Door Hinge Leaf	9845-005-002	1
10	Masking Ring Assembly (For Micro Switch Box Door Switch)	9950-060-002	1
16	Switch Box Assembly, Door Closure (#17 thru #20)	9801-089-001	1
17	Box-Door Switch	9041-087-001	1
18	Bushing-Insulating, Plastic	9053-067-003	1
15	Switch-Micro	9539-461-007	1
*	Shield-Doorswitch	9550-159-001	1
19	Nut-Special Twin, #4/40	8640-401-001	1
*	Screw, 4/40 x 5/8	9545-020-001	2
*	Red Wire (Door Close Switch)	8220-062-027	1
*	Black Wire (Door Close Switch)	8220-062-028	1
20	Acuator-Doorswitch	9008-004-001	1

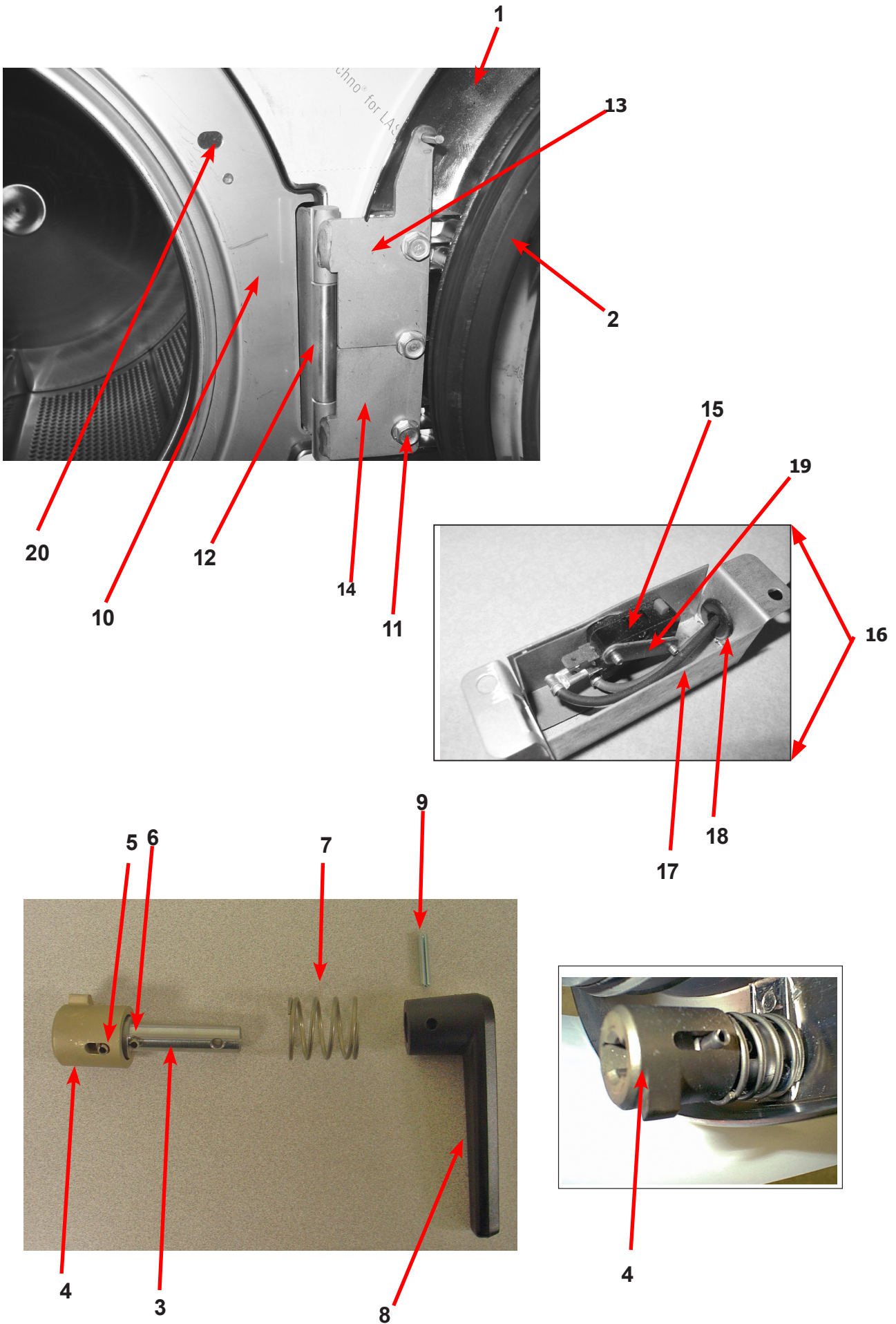

Drain Valve Group Part # by Model

Key	Description	Part Number	Qty
1	Valve, Drain (includes #2 thru #11)	9379-202-001	1
2	Body, Valve (w/ball)	9064-070-001	1
3	Motor & Gear Train (complete)	9914-137-011	1
4	Plate, Motor Mtg	9452-538-001	1
5	Screw	8639-994-001	1
6	Spring, Drive	9534-339-001	1
7	Screw	9545-054-001	1
8	Screw	9545-054-002	1
9	Seal, V Packer	9532-134-001	1
10	Washer	8641-584-001	1
11	Pin, Main Drive	9451-196-001	1
*	Plate (spacers needed for replacement motor mtg. plate)	9538-149-001	1
13	Stator and Coil Assembly	9089-036-004	1
*	Replacement Seal Kit	9732-327-001	*

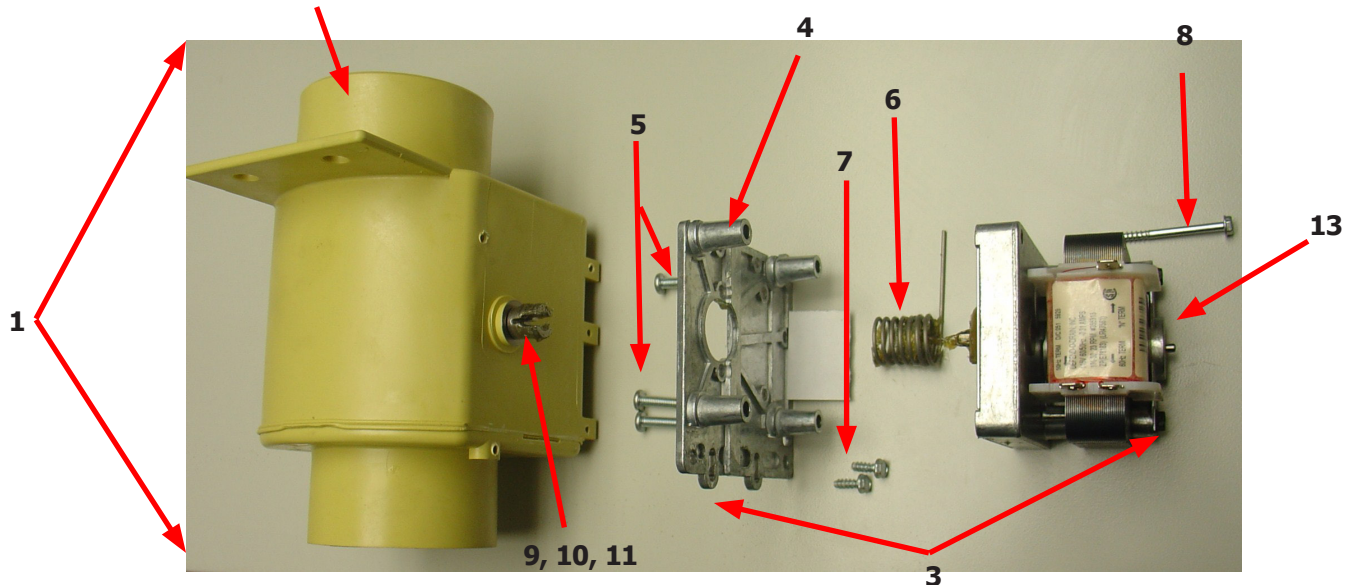
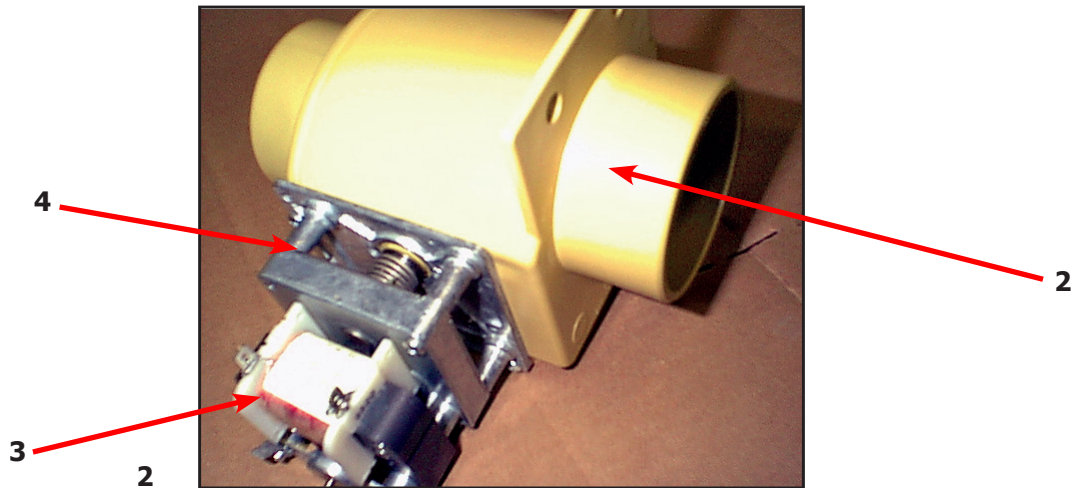

Water Inlet Valve Breakdown

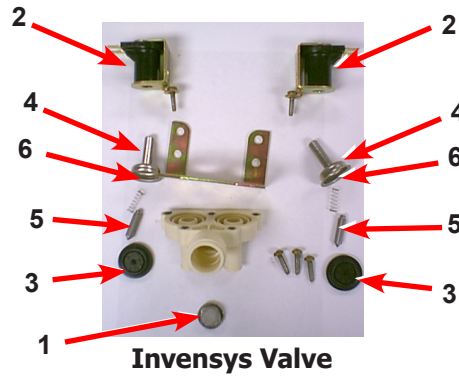

Key	Description	Part Number	QTY
*	Valve, Water Inlet (includes 1 thru 6) - Invensys	9379-183-012	2
1	Screen, Inlet end of valve	9555-056-001	2
2	Coil Assy., 120 V Invensys	9089-017-001	2
3	Diaphragm Invensys (EPDM NSF)	9118-049-003	2
4	Guide, Solenoid Invensys	9211-021-002	2
5	Armature Invensys	9015-008-001	2
6	Spring, Armature Invensys	9534-298-001	2
*	Optional Diaphran (Viaton)	9118-049-002	2
*	Wiring Harness	9794-001-001	1

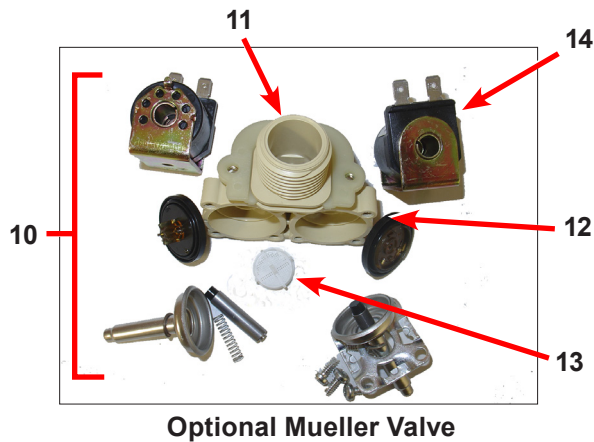

Key	Description	Part Number	QTY
10	Dual Coil Water Valve Mueller	9379-192-001	2
11	Valve Water Body Complete (no coil)	9379-192-002	1
12	Diaphragm Mueller	9118-054-001	2
13	Filter Mueller	9183-046-001	1
14	Coil Mueller	9089-051-001	2
16	Diaphragm Assembly Mueller	9785-001-001	1

WSAD Chassis and Drain by Part

Key	Description	Part Number	Qty
1	Base Assy,Frame	9945-109-002	1
*	Outer Tub Assy	9930-140-001	1
*	Cylinder Assembly, (Includes Spider)	9848-120-001	1
3	Back Ass'y, Tub	9962-013-003	1
4	Bolt, 7/16" x 2" Tub Back to Tub	9545-059-002	12
5	Nut, Flange Lock	8640-416-005	12
*	Bolt, 5/8-11 x 1 1/2 Tub to Base, Front	9545-060-001	2
*	Nut, 5/8-11 Wizlok	8640-425-001	2
*	Ring Assy, Tub Mtg-Front	9950-051-004	1
*	Bolt, Top Front Ring 5/8" x 3"	9545-017-016	1
*	Nut WCAD 5/8"	8640-417-005	1
6	Ring Assy.Clamp Tub Mtg.- Rear	9950-056-002	1
7	Bolt, 5/8-11 x 1 1/2 Tub to Base, Rear	9545-060-001	2
8	Nut, 5/8-11 Wizlok	8640-425-001	2
9	Bolt, 5/8-11 x 2 Tub & Rings to Base, Front & Rear	9545-060-004	4
10	Washer	8641-581-038	4
11	Nut, 5/8-11 Wizlok	8640-425-001	4
12	Hose, Overflow	9242-449-004	1
13	Clamp	8654-117-018	2
14	Tube, Over Suds	9242-463-005	1
*	Clamp	8654-117-014	1
15	Hose, Tub to Drain Valve	9242-464-001	1
16	Valve, Drain	9379-187-004	1
*	Bracket, Drain Valve		
*	Screw, Valve to Bracket 5/16-18x1 1/4	9545-014-012	2
*	Nut, 5/16-18	8640-400-003	2
17	Hose, Drain Valve to Tube	9242-457-001	1
*	Clamp, Hose (Drain Valve to Tube)&(Strain Hose to Valve)	8654-117-009	2
*	Screw Tube (Bracket to Base 1/4B x 3/4)	9545-030-002	2
18	Tube Assy, Drain	9915-122-002	1
19	Hose, Vacuum Brkr. to Tub	9242-458-001	1
	Clamp	8654-117-014	2
20	Hose, Pressure Switch	9242-175-005	1

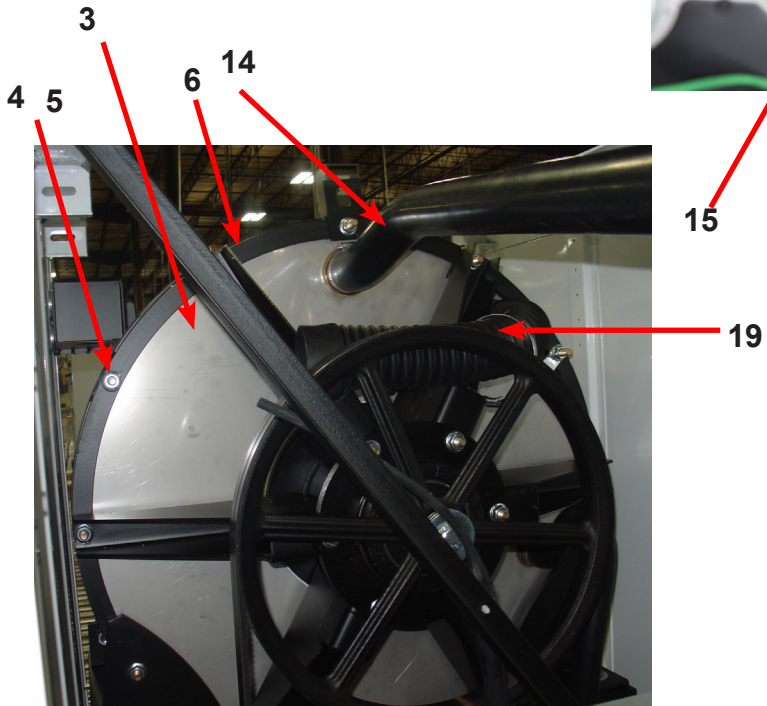
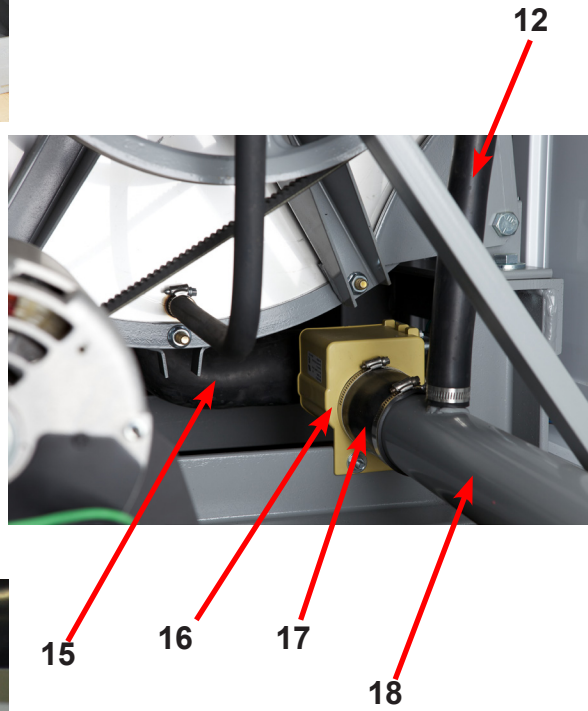
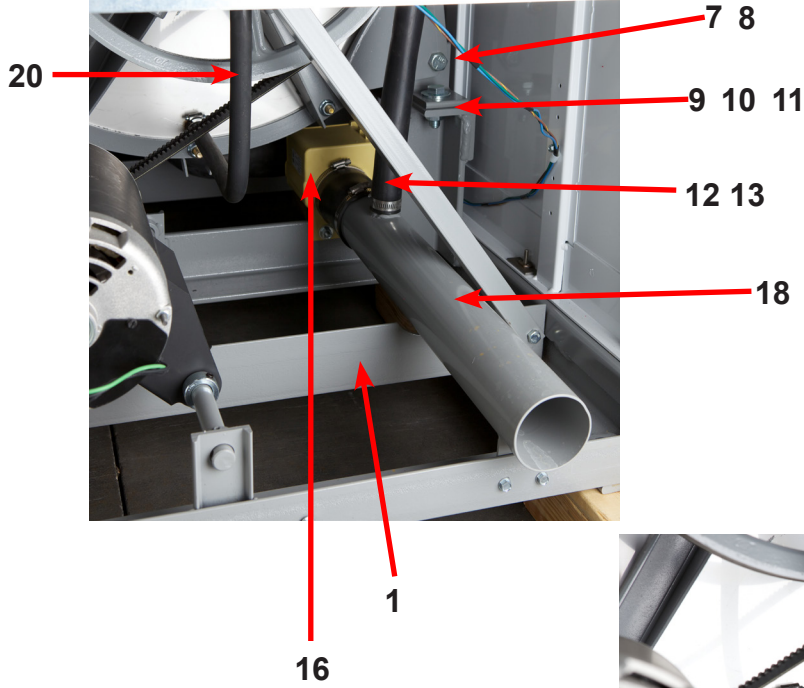
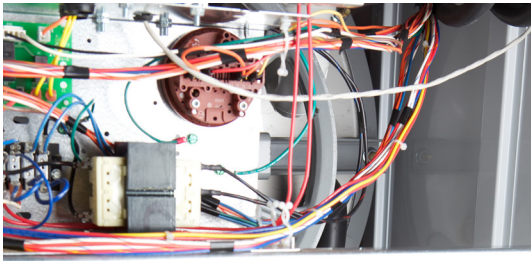

WSAD Electrical Components, Control

Key	Description	Part Number	Qty
1	Trough Assy,Controls 208-240 volt	9857-156-001	1
	Trough only	9839-015-001	1
2	Transformer, Control (208/230/60 Hz In 115,150VA Out Volts)	8711-004-001	1
*	Wire Assembly, Red 28"	8220-062-025	2
*	Screw, #10B x 1/2	9545-008-026	4
*	Lockwasher #10	8641-582-006	4
*	Wire Assembly, BLK/BLU	8220-001-231	1
*	Terminal Block Assy, POWER	9897-034-001	1
*	Screw, Mtg 8Bx3/4"	9545-045-007	2
*	Strip, Terminal Marker	9558-027-001	1
*	Wire Assembly-Jumper, BLU/WHT	8220-090-009	1
3	Transformer, Step Down (120VAC In, Sec-1, 24.3, Sec-2, 2.3VAC)	8711-010-001	1
*	Harness-extention, Transformer	9627-826-001	1
*	Screw, 8B x 1/4	9545-045-001	2
*	Lockwasher #10	8641-582-005	2
*	Wire Assembly, P12, Red 7"	9631-381-018	1
4	PCB assembly Relay Main	9473-006-001	1
*	Wiring Harness, Door Lock P15/P4	9627-816-002	1
*	Wiring Assembly Yel. 32" P14 & P13	8220-064-023	2
5	Wiring Harness, Drain,Thermo,DoorSol P17	9627-820-001	1
6	Wiring Harness WaterValve/P19	9627-795-004	1
7	Wiring Harness P8/P16	9627-819-001	1
*	Wiring Harness P20/P21	9627-818-001	1
8	Pressure Switch	9539-490-001	1
9	Harness Assembly, Pressure Switch	9627-822-001	1
*	Electronic Pressure Swtich Kit	9732-314-001	*

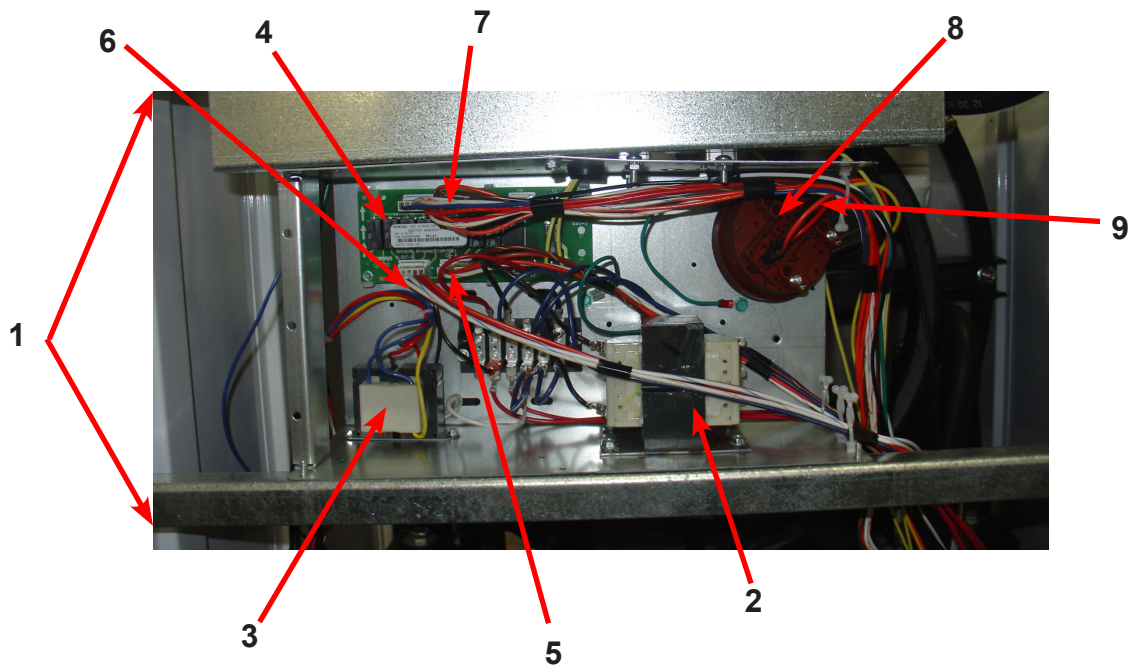

WSAD Electrical Components, Upper

Key	Description	Part Number	Qty
1	Terminal Block Assy, POWER	9897-033-002	1
*	Screw, Mtg 6ABx3/4"	9495-031-010	2
2	Strip, Terminal Marker	9558-025-001	1
3	Terminal, Lug-Solderless (Ground)	8652-134-001	1
*	Screw, 10-32TTx1/2 Green (Control Trough)	9545-008-027	
*	Wiring Harness Power Terminal To VFD & Control Transformer and ground wire	9627-747-002	1
4	VFD Delta drive 208-240 volt	9375-015-014	1
*	Cable, Data Communication	9806-015-002	1
*	Wiring Assembly Yel. 32"	8220-064-023	2
5	Braking resistors (200 ohm)	9483-004-002	3
*	Wire Assembly, BLK (Breaking Resistors)	8220-118-002	2
*	Wire Assembly-Jumper, BLK (Breaking Resistors)	8220-117-002	2
*	Label Fuse 1.5 amp Rear	8502-716-001	
*	Fuse-1.5a	8636-018-001	1
6	Fuseholder-Assembly	9200-001-002	1
*	Circuit Breaker (optional) 1.5 AMP	5198-211-004	1

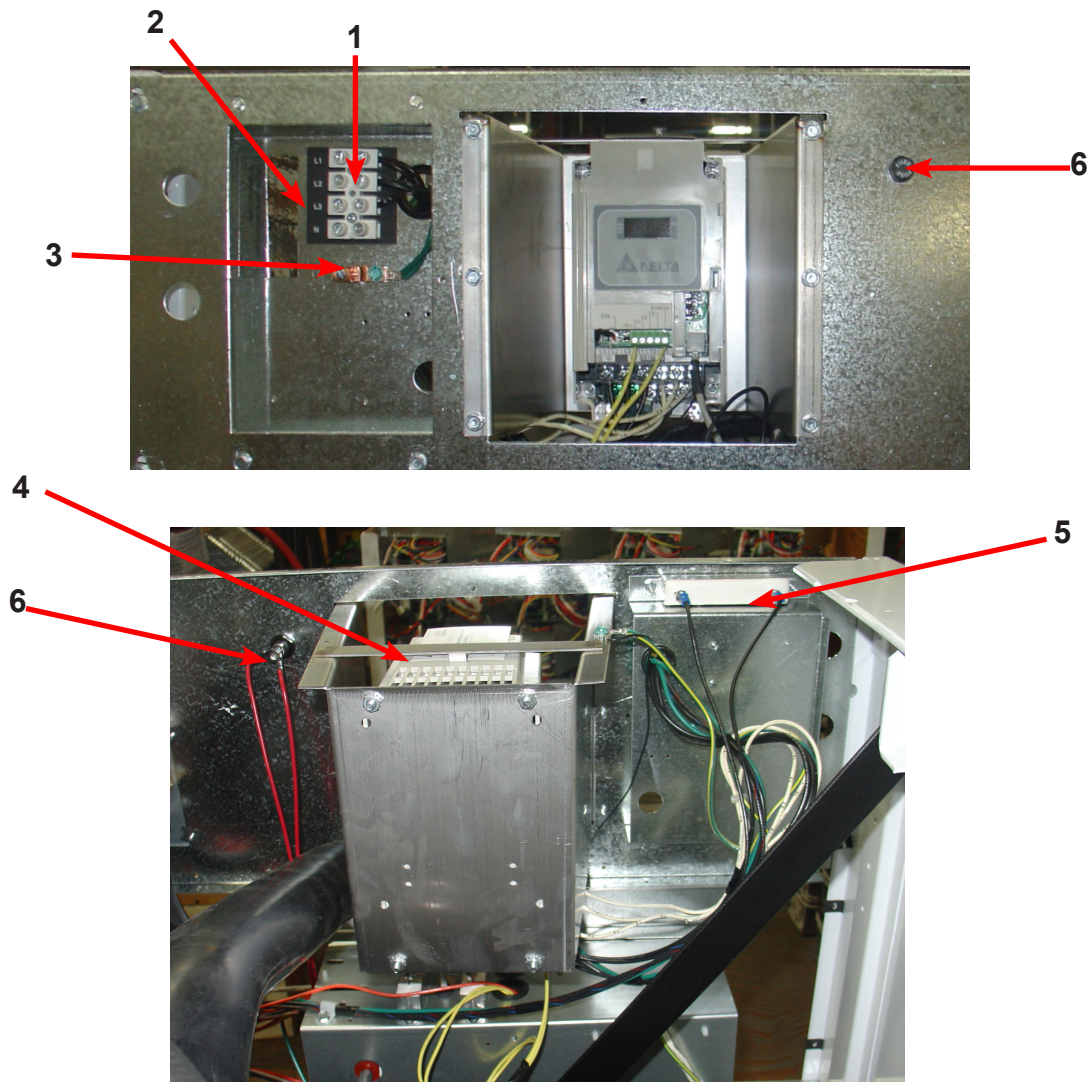

WSAD Front Panel Control Group Part

Key	Description	Part Number	Qty
*	Nameplate,Control Panel (one piece)	9412-143-001	1
1	PCB assembly Control /Display	9473-009-005	1
*	Spacer Pushbutton (Micro)	9538-178-001	1
*	Retainer Pushbutton (Micro)	9486-150-001	1
*	Nut Hexelasticstop #4-40	8640-424-002	2
*	Pushbutton Control (coin)	9035-060-003	1
*	Spacer Plastic #6x9/16	9538-157-018	5
*	Nut Elasticstop #6-32	8640-411-002	4
*	Nut-Hexkeps, #6-32	8640-411-003	1
2	Harness LEDPCB	9627-821-001	1
3	Harness Doorlock, Switches	9627-816-002	1
4	PCB assembly Mode lights	9473-005-001	1
*	Spacer Plastic #6x9/16	9537-157-018	2
*	Nut Hexkeps #6-32	8640-411-003	2
5	Light, LED,ADD BLEACH Assembly	9794-001-001	1
*	Spacer Plastic #6x9/16	9538-157-018	2
*	Nut Hexeps #6-32	8640-411-003	2
*	Switch Assembly Emergency Stop (includes Wire Harness)	9732-223-002	1
*	Spacer Plastic #8x5/16 E-Stop	9538-157-020	2
*	Nut HexKep #8-32 E-Stop	8640-412-005	2
6	Solenoid Ass'y, Door Locking See Door Lock Group for Parts Breakdown)	9922-011-009	1
*	Hex Nuts (mounting solenoid assy. To Control)	8640-412-005	3
7	Battery	8612-001-001	1
*	Plate to mount e-stop button	9452-725-001	1

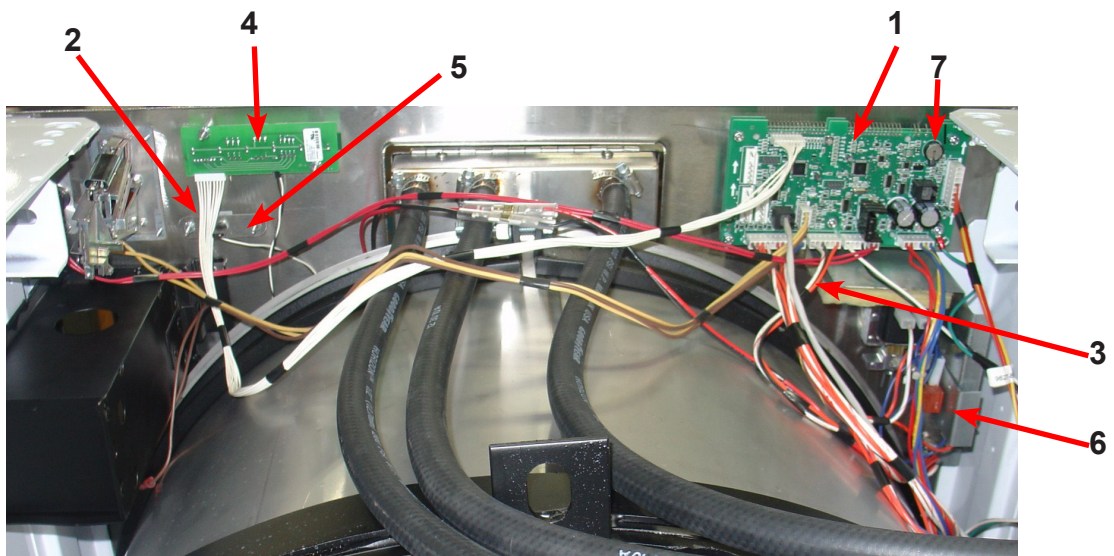

WSAD Labels and Diagrams by Part

Key	Description	Part Number	Qty
*	Wiring Diagram, Coin	9506-123-001	1
*	Wiring Schematic, Coin	9506-122-001	1
*	Wiring Diagram (Easy Card)	9506-109-001	1
*	Wiring Schematic, (Easy Card)	9506-108-001	1
*	Transient Voltage Surge Suppressor Informational	8507-330-001	1
1	Label High Voltage Warning	8502-614-005	1
2	Label Fusing & Installation	8502-619-004	1
3	Label Warning Risk of Injury	8502-722-001	1
4	Label Warning Door Opening	8502-723-001	1
*	Booklet Owners	8514-198-001	1
5	Label Top Dispenser	8502-687-001	1
6	Label-Connection Electrical	8502-649-001	1
7	Label-"EXPRESS", Soap Dispenser	8502-715-001	1

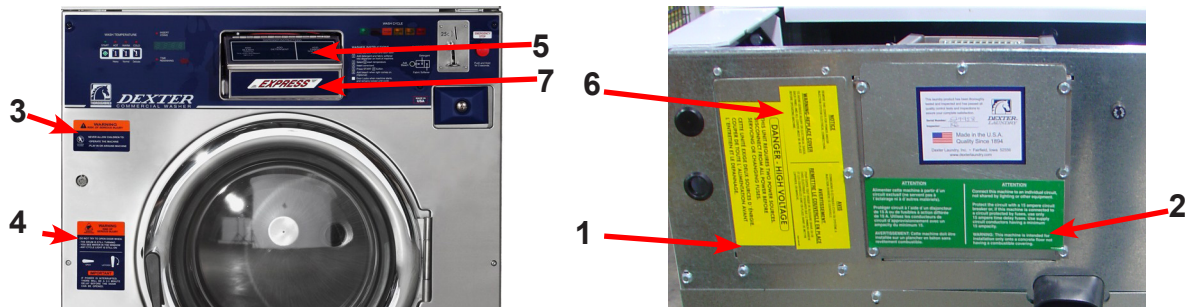

WSAD Coin Handling by Part

Key	Description	Part Number	Qty
7	Vault, Assy	9942-028-003	1
*	Screw, 10B x 1/2" Vault Mtg	9545-008-026	4
8	Coin Acceptor Optical	9021-092-002	1
*	Coin Acceptor chute without penny rejector (Standard)	9119-025-002	1
10	Coin Acceptor chute with penny rejector (Optional)	9119-025-001	1
*	Screw, Acceptor Mtg	9545-053-002	4
*	Button Coin Return Retainer	9486-145-001	1
9	Micro Switch, Coin Count	9539-466-005	1
*	Harness Coin Switch	9627-817-001	1

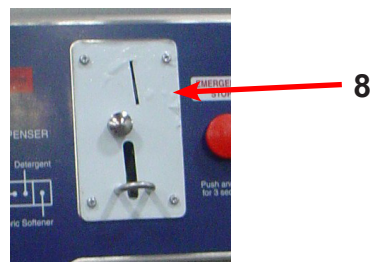
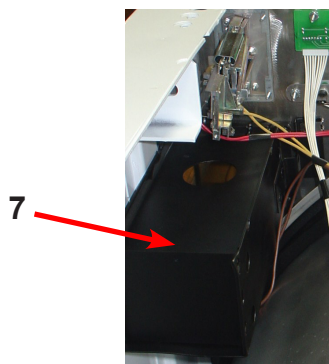

Coin Handling Group

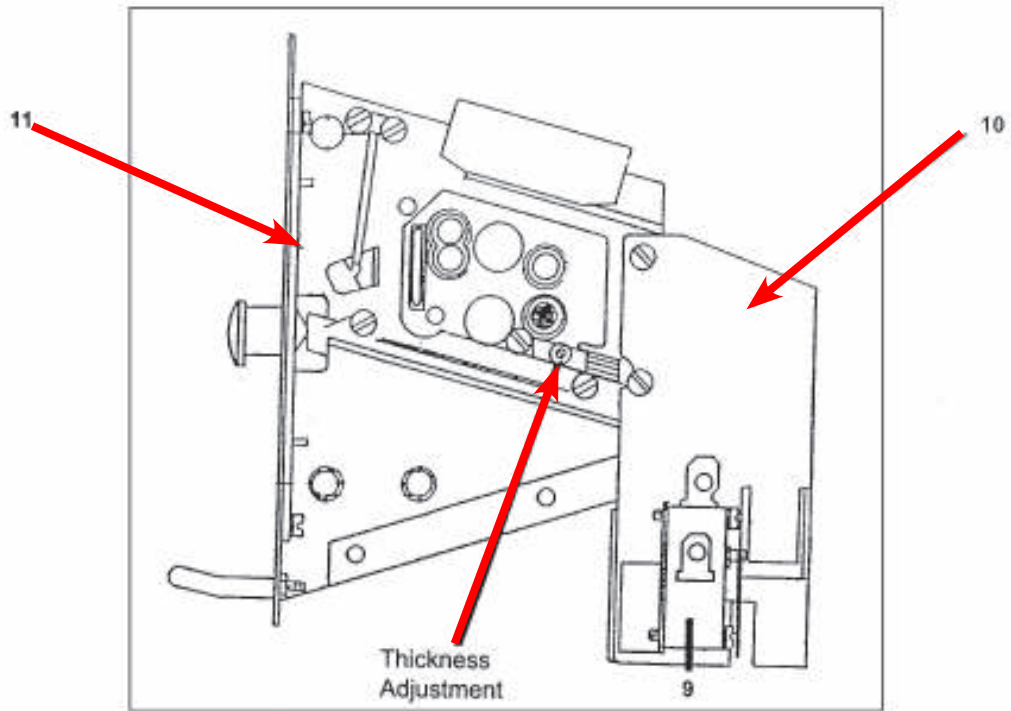

#8 COIN ACCEPTOR - right side

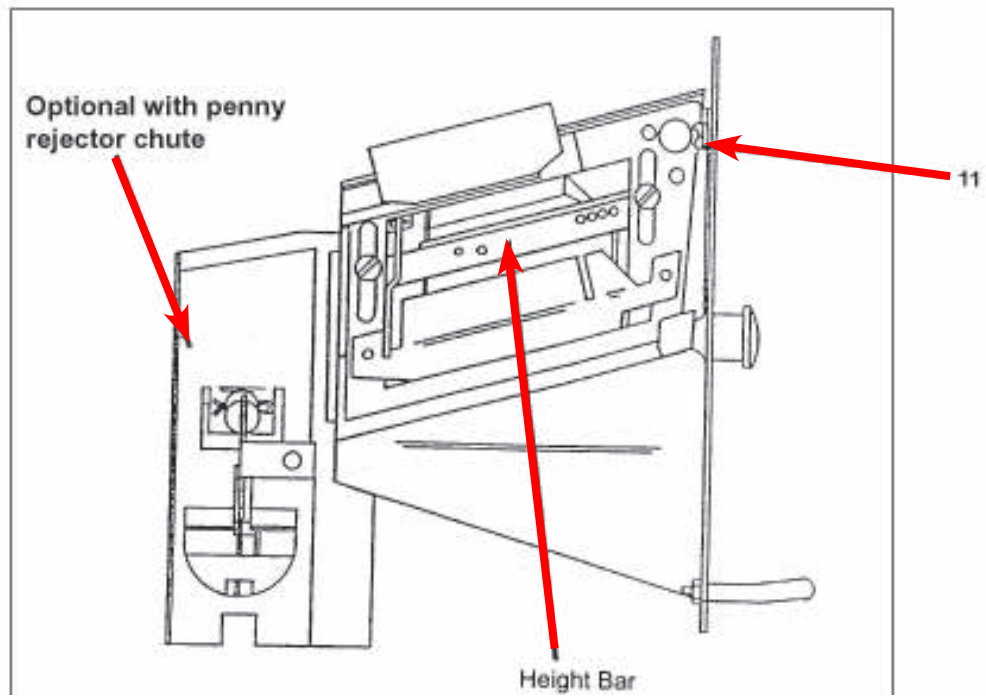

WSAD Kit - Electronic Acceptor

Key	Description	Part Number	Qty
*	KIT - Electronic Acceptor Conversion for WSAD (UAS & Canada) Contact the Dexter Factory for other Countries	9732-213-007	1
*	Electronic Coin Acceptor (USA & Canada)	9021-010-001	1
*	Harness for Electronic Coin Acceptor	9627-845-001	1
*	Transformer 120/18VAC	8711-015-001	1
*	Wire Assembly - Blue	8220-001-338	1
*	Wire Assembly - Orange/White	8220-001-235	1
*	Wire Assembly - White/Blue	8220-062-001	2
*	Nut - Hex Elastic Stop	8640-411-002	2
*	Screw, Torx	9545-053-002	8
*	Acceptor Retainer	9486-155-001	2
*	Label, Informative	6102-017-001	1
*	Label, Warning	8502-730-001	1
*	Instructions, Installation	8507-367-002	1

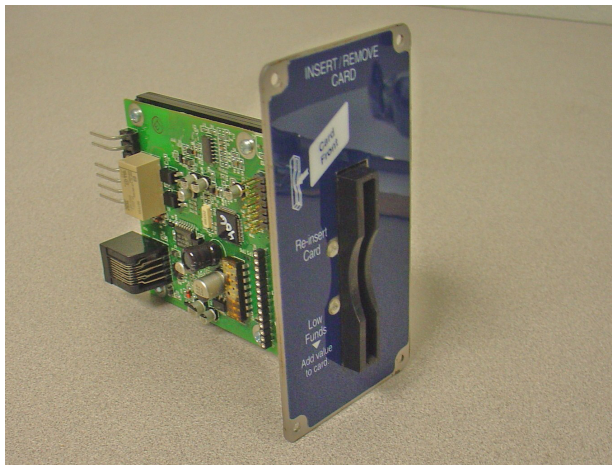

WSAD Integrated EasyCard by Part

Key	Description	Part Number	Qty
*	Panel Assembly (panel only)	9989-506-001	1
*	Nameplate, Control Panel (one piece)	9412-152-001	1
*	Harness, EasyCard V&A-reader ALL MODELS	9627-827-002	1
*	Card Reader Assembly Complete	9797-008-001	1
*	Card Reader (IC reader only)	9797-007-003	1
*	Cable Assembly 4 twisted pair 12' shld/unshield reader to rear of machine	9806-013-002	1
*	Wiring Schematic, Easy Card	9506-108-001	1
*	Wiring Diagram (Easy Card)	9506-109-001	1

Section 11:

50 Hz Washer

Models

Parts in this section used only in these models. All other parts are same as standard 60 Hz pages.

Transformers and Coin Handling -21 Models

KEY	Part Description	WSAD30KCS-21CR	QTY
*	Wire Assembly -Orange/White	8220-001-235	1
*	Wire Assembly -Blue	8220-001-338	1
*	Label-Warning, Electronic Coinacceptor	8502-730-001	1
*	Lockwasher-Exttooth,#6	8641-582-005	4
1	Transformer-120/18zVAC,5VA	8711-015-001	1
2	Transformer, Control	8711-004-002	1
3	Transformer, Secondary	8711-010-002	1
4	Acceptor-Coin,Electronic	9021-013-001	1
*	Wiringlabel-Schematic	9506-166-001	1
*	Wiringlabel-Diagram	9506-167-001	1
*	Screw-Hx 10bx1/4	9545-008-001	7
*	Screw-Hx ,8bx1/4	9545-045-001	6
6	Harness-Electronic Coin Acceptor	9627-845-001	1
*	Controlsassembly -Trough	9857-156-004	1

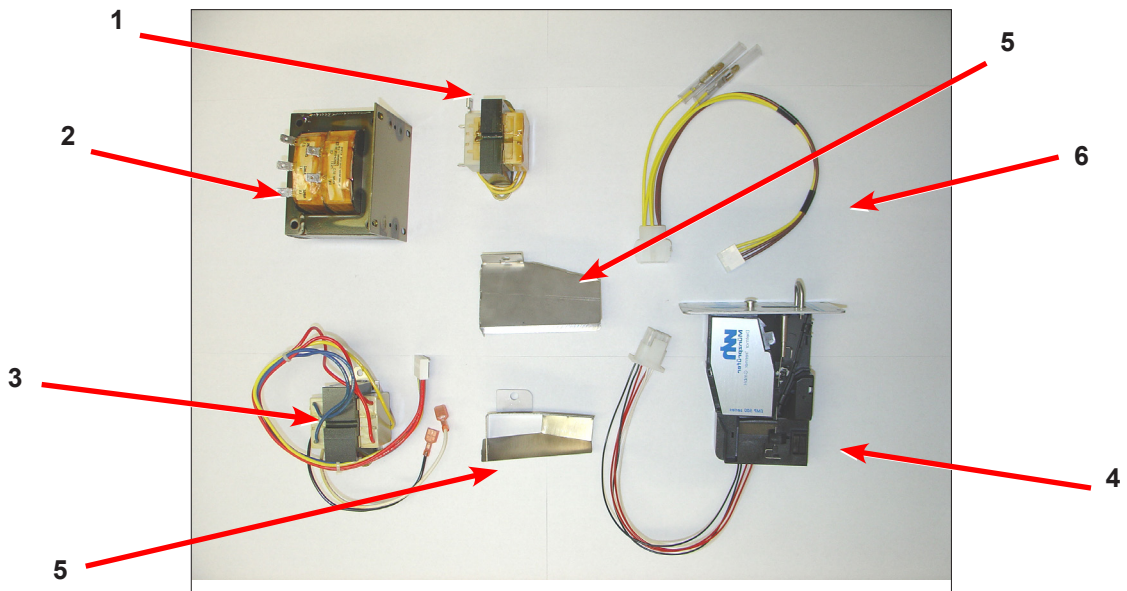

Wiring Schematic for 50hz Washer -21CR

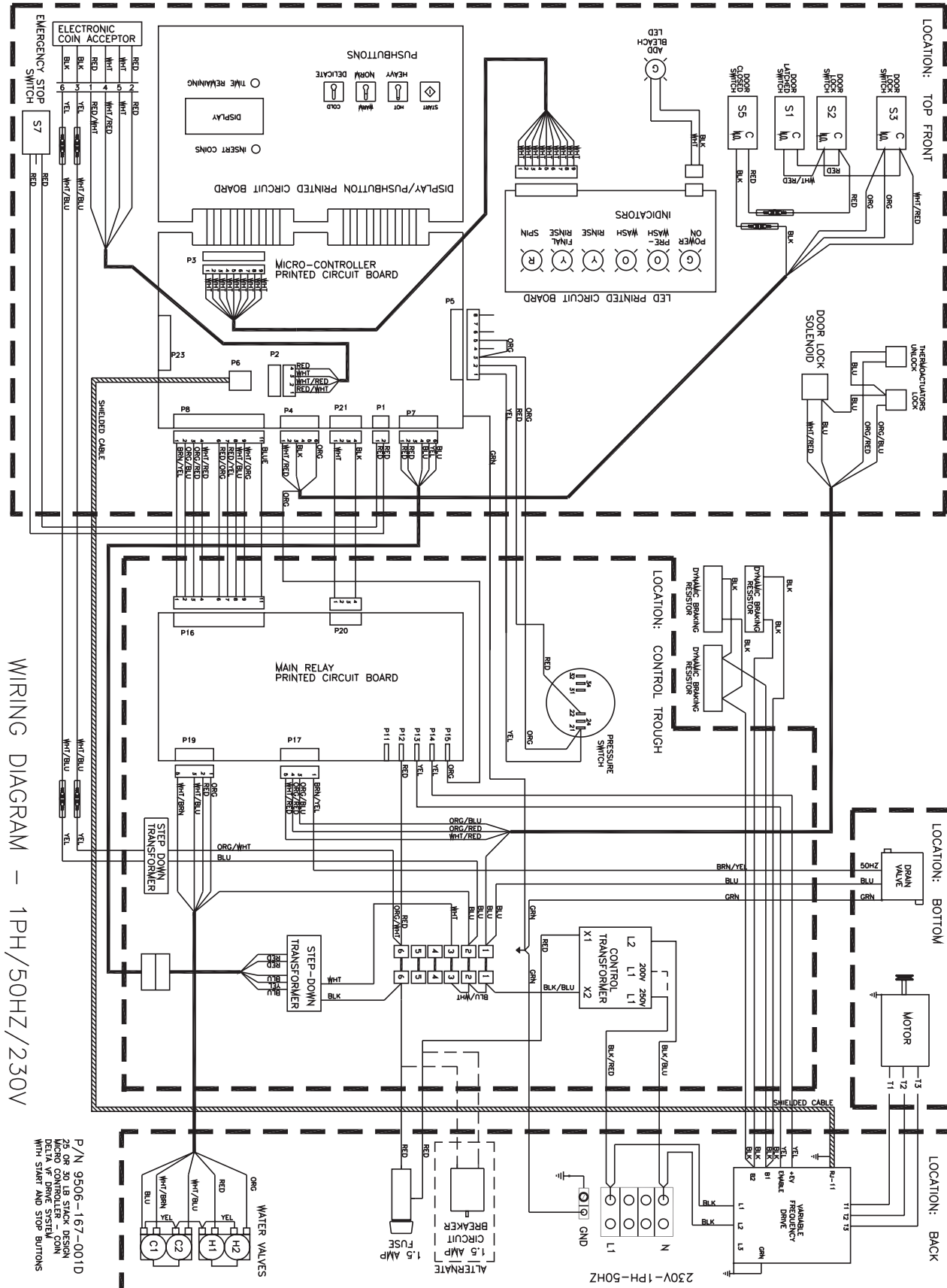

P/N 9506-167-001D
 5/08 21CR
 MICRO CONTROLLER
 DELTA VFD DRIVE SYSTEM
 WITH START AND STOP BUTTONS

Wiring Diagram for 50hz Washer - 21CR

230V-1PH-50HZ

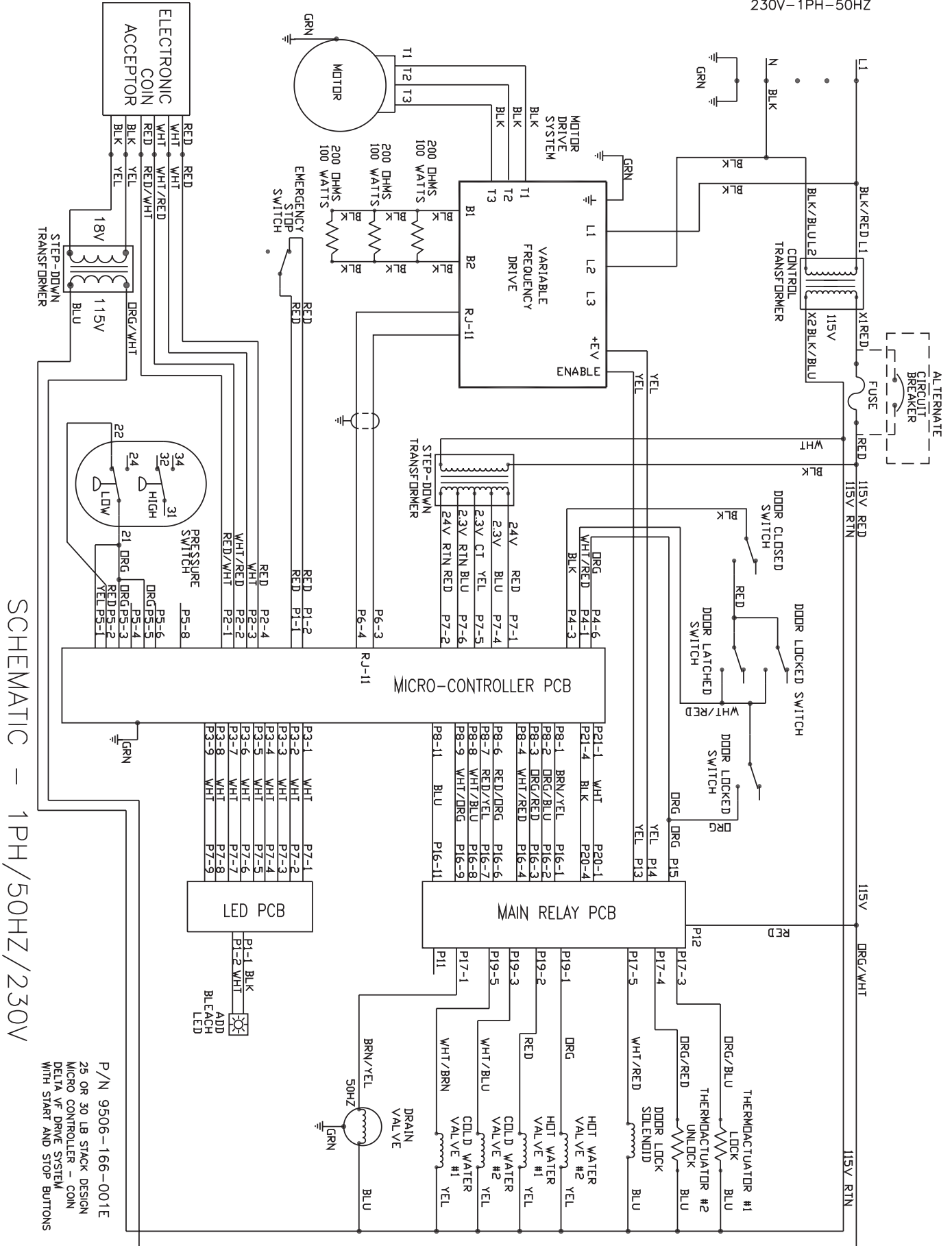

SCHEMATIC - 1PH/50HZ/230V

P/N 9506-166-001E
 25 OR 30 LB STACK DESIGN
 MICRO CONTROLLER - COIN
 DELTA V.F. DRIVE SYSTEM
 WITH START AND STOP BUTTONS

Section 12:

Maintenance

Washer and Dryer

Preventative Maintenance

Daily

- Step 1:** Clean the lint screen free of lint and other debris. Use a soft brush and Hot water if necessary.
- Step 2:** Check the lint screen for tears. Replace if necessary.
- Step 3:** Clean lint from the lint screen compartment.
- Step 4:** Inspect felt seal on lint screen assembly, replace if needed.

Monthly

- Step 1:** Remove lint accumulation from the end bells of the motor.
- Step 2:** Remove lint accumulation from front control area.
- Step 3:** Remove lint and dirt accumulation from the top of the dryer and all areas above, below, and around the burners and burner housing. Failure to keep this portion of the dryer clean can lead to a build-up of lint creating a fire hazard.
- Step 4:** Remove and clean coin acceptors. (Vended Models Only)

Quarterly

- Step 1:** Check the belts for looseness, wear, or fraying.
- Step 2:** Inspect the gasket of the door glass for excessive wear.
- Step 3:** Check tightness of all fasteners holding parts to support channel.
- Step 4:** Check tightness of all set screws.
- Step 5:** Remove the air flow switch assembly and check the tumbler thru-bolts for tightness.
- Step 6:** Apply a few drops of oil to pivot pins and the tension arms where in contact with each other.

Semi-Annually

- Step 1:** Remove and clean the main burners.
- Step 2:** Remove all orifices and examine for dirt and hole obstruction.
- Step 3:** Remove all lint accumulation. Remove the front panel and the lint screen housing and remove lint accumulation.

Annually

- Step 1:** Check the intermediate pulley bearings for wear.
- Step 2:** Check and remove any lint accumulation from the exhaust system including recirculation chambers if applicable.
- Step 3:** Grease the bearings and the shaft of the intermediate pulley. Use an Alemite grease gun and Molykote BR2-S grease. (Where applicable)

Preventative Maintenance

Daily

- Step 1:** Check that the loading door remains securely locked and cannot be opened during an entire cycle.
- Step 2:** Clean the top, front, and sides of the cabinet to remove residue.
- Step 3:** Clean the soap dispenser and lid and check that all dispenser mounting screws are in-place and tight.
- Step 4:** Check the loading door for leaks. Clean the door seal of all foreign matter.
- Step 5:** Leave the loading door open to aerate the washer when not in use.

Quarterly

- Step 1:** Make sure the washer is inoperative by switching off the main power supply.
- Step 2:** Check the V-belts for wear and proper tension.
- Step 3:** Clean lint and other foreign matter from around motor.
- Step 4:** Check all water connections for leaks.
- Step 5:** Check the drain valve for leaking and that it opens properly.
- Step 6:** Wipe and clean the inside of the washer and check that all electrical components are free of moisture and dust.
- Step 7:** Remove and clean water inlet hose filters. Replace if necessary.
- Step 8:** Check anchor bolts. Retighten if necessary.

