

EXTERNAL GROUND MUST BE A NATIONAL/LOCAL ELECTRICAL CODE APPROVED GROUND AND CONNECTED TO THE DRYER GROUNDING TERMINAL.

CAUTION: LABEL ALL WIRES PRIOR TO DISCONNECTION WHEN SERVICING CONTROLS. WIRING ERRORS CAN CAUSE IMPROPER AND DANGEROUS OPERATION. VERIFY PROPER OPERATION AFTER SERVICING.

ATTENTION. AU MOMENT DEL'ENTRTIEN DES COMMANDES, ÉTIQUETEZ TOUS LES FILS AVANT DE LES DÉBRANCHER. DES ERREURS DE CÂBLAGE PEUVENT ENTRAÎNER UN FONCTIONNEMENT INADÉQUAT ET DANGEREUX. S'ASSURER QUE L'APPAREIL FONCTIONNE ADÉQUATEMENT UNE FOIS L'ENTRETIEN TERMINÉ.

NOTES:

1. DOOR SWITCHES—N.O., CLOSED WHEN DOORS ARE CLOSED.
2. MOTOR RUN RELAY CONTACT WILL CLOSE WHEN THE COIN COUNT IS SATISFIED, THE DOOR CLOSED AND THE START BUTTON PRESSED
3. CENTRIFUGAL SWITCH—N.O., CLOSSES WHEN MOTOR IS UP TO SPEED.
4. REFER TO OWNER'S MANUAL FOR DESCRIPTION OF OPERATION AND REQUIREMENTS FOR HEATING CIRCUIT.
5. WITH A DC MICROAMMETER, FLAME CURRENT CAN BE MEASURED AT TEST POINTS. READING SHOULD BE 0.7µA DC OR HIGHER.

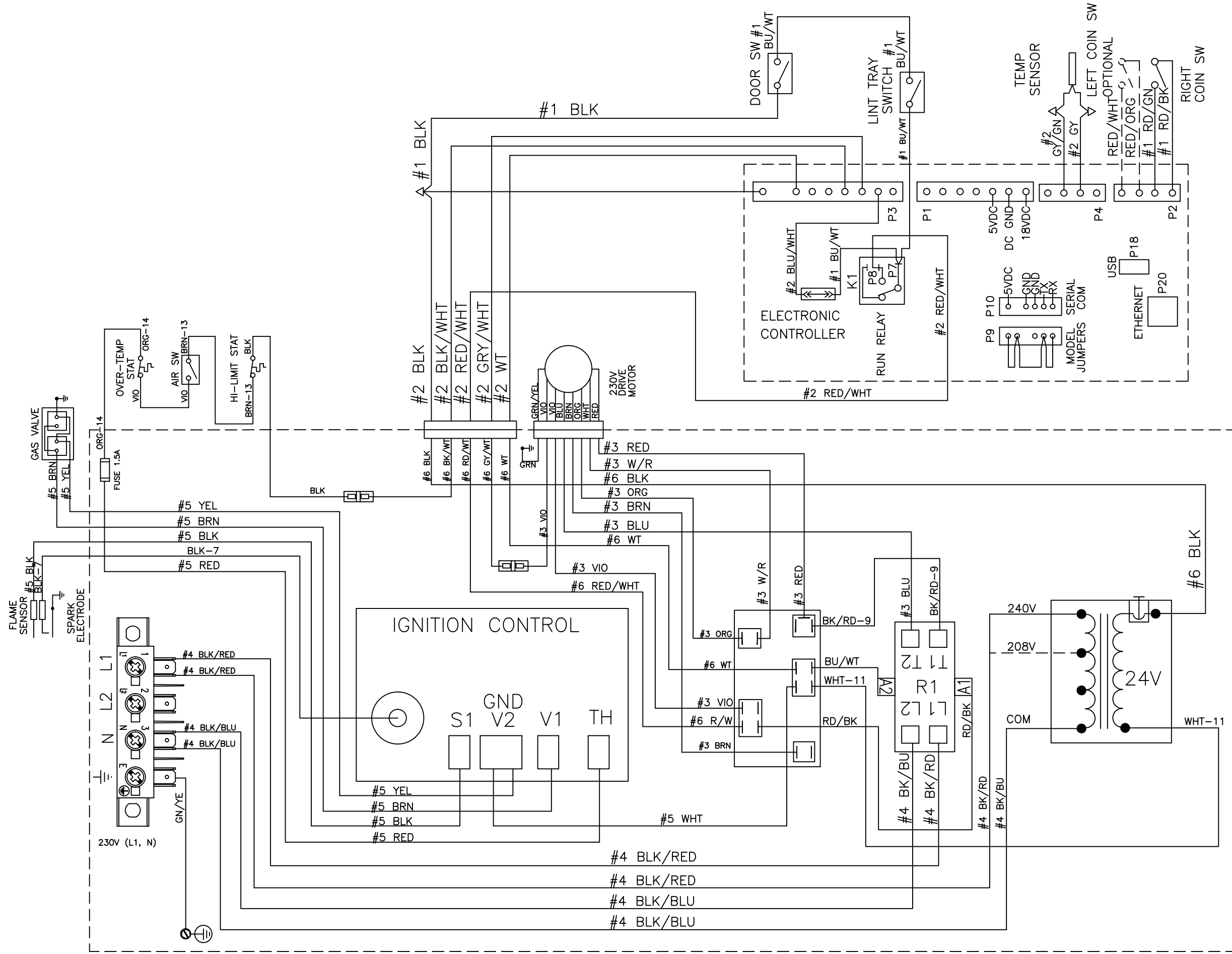

9506-819-001PR WIRING DIAGRAM DCS020N\_-39\_C\_X-\_\_X

**IMPORTANT: RETAIN THIS ELECTRICAL DIAGRAM FOR SERVICE.**