

230V-1PH-50HZ

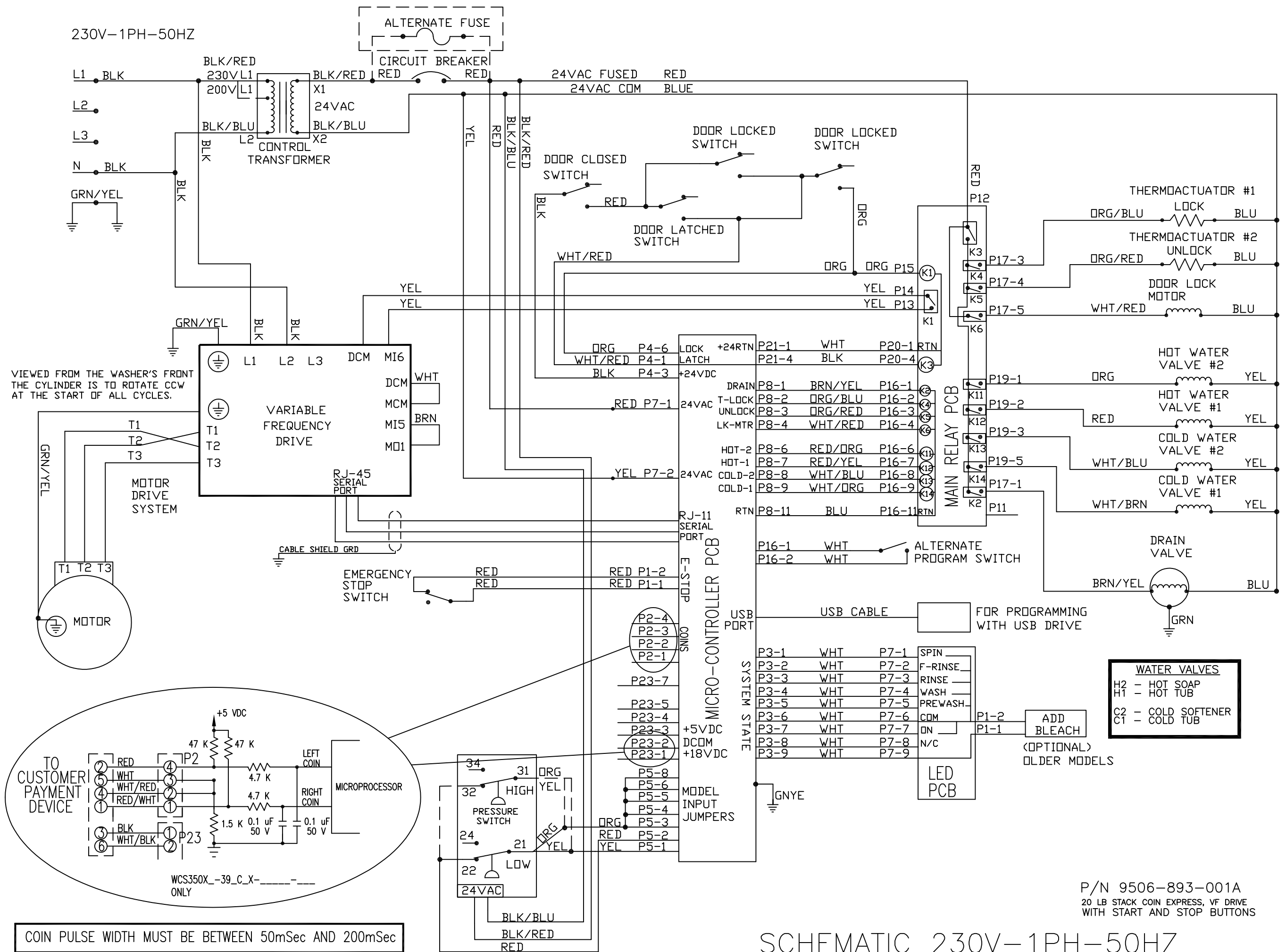

VIEWED FROM THE WASHER'S FRONT THE CYLINDER IS TO ROTATE CCW AT THE START OF ALL CYCLES.

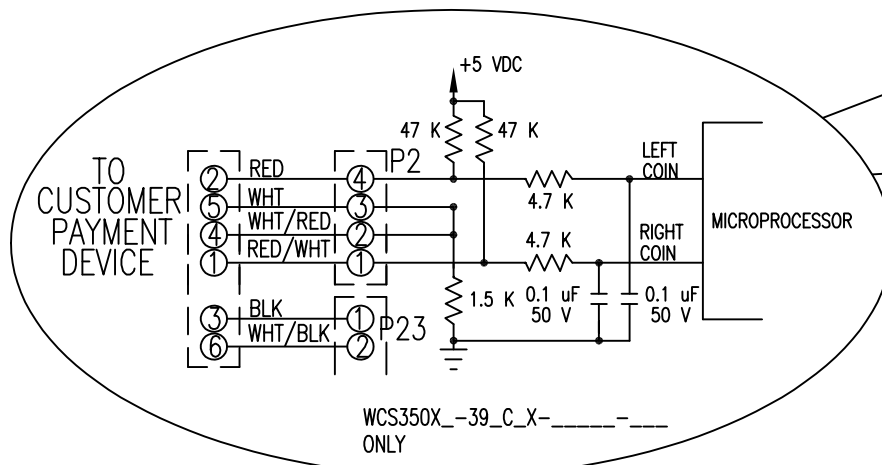

COIN PULSE WIDTH MUST BE BETWEEN 50mSec AND 200mSec

WATER VALVES	
H2	HOT SOAP
H1	HOT TUB
C2	COLD SOFTENER
C1	COLD TUB

P/N 9506-893-001A
20 LB STACK COIN EXPRESS, VF DRIVE
WITH START AND STOP BUTTONS

SCHEMATIC 230V-1PH-50HZ

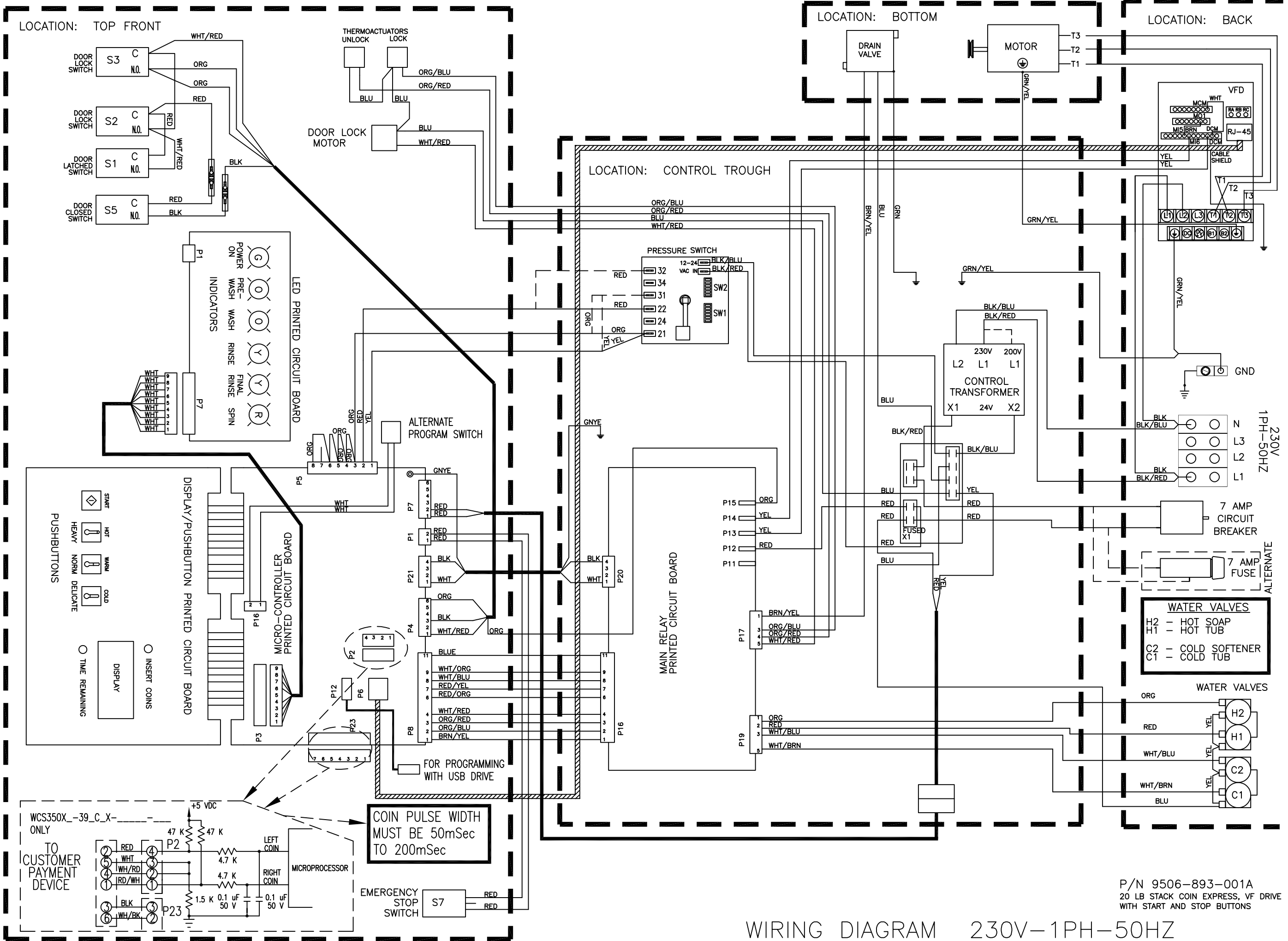

WATER VALVES
 H2 - HOT SOAP
 H1 - HOT TUB
 C2 - COLD SOFTENER
 C1 - COLD TUB

P/N 9506-893-001A
 20 LB STACK COIN EXPRESS, VF DRIVE
 WITH START AND STOP BUTTONS

WIRING DIAGRAM 230V-1PH-50HZ