

# TABLE OF CONTENTS

## SECTION 1 — PRIMARY SERVICE DATA

	PAGE		PAGE
Uncrating .....	1-1	Main Burner Adjustment .....	1-5
Equipment Installation .....	1-1	Exhausting .....	1-5
Electrical Requirements .....	1-2	Operating Instructions .....	1-8
Clearance Requirements .....	1-2	Specifications .....	1-14
Gas Requirements .....	1-2	Dimensions .....	1-15
Orifice Capacity Chart (Table I) .....	1-4		
Orifice Capacity BTU/Hr. (Table II) .....	1-4		

## SECTION 2 — WIRING DIAGRAM

Coin Metered & Manual Models .....	2-1
------------------------------------	-----

## SECTION 3 — SERVICE PROCEDURES

Upper Service Door Removal .....	3-1	Spark Electrode - Function .....	3-8
Coin Acceptor Removal .....	3-2	Ignition System - Sequence .....	3-8
Clothes Door Removal .....	3-3	Ignition - Check Out .....	3-8
Installation and Adjustment - Clothes Door .....	3-3	Spark Electrode - Removal .....	3-8
Door Handle Disassembly .....	3-3	Gas Valve & Manifold Removal .....	3-9
Installation - Clothes Door Window and Gasket .....	3-4	Burner Orifice Removal .....	3-9
Door Switch Removal and Installation .....	3-4	Burner Removal .....	3-9
Lower Service Door .....	3-4	Pressure Regulator Adjustment .....	3-9
Front Panel Removal .....	3-4	Motor & Impeller Removal .....	3-9
Lint Screen and Lint Hood Removal .....	3-4	Belt Removals .....	3-10
Blower Impeller Removal .....	3-5	Pulley Removals .....	3-10
Damper Switch Removal and Adjustment .....	3-5	Cylinder Removal .....	3-11
Hi-Limit Thermostat .....	3-6	Cylinder Adjustment .....	3-12
Gas Control Valve .....	3-6	Bearing Housing Removal .....	3-13
Electronic Module - Function .....	3-8		

## SECTION 4 — PREVENTIVE MAINTENANCE & TROUBLE SHOOTING GUIDE

Preventive Maintenance Schedule .....	4-1	Trouble Shooting Guide .....	4-1,2,3
---------------------------------------	-----	------------------------------	---------

## SECTION 5 — PARTS DATA

	KEY LETTER		KEY LETTER
Cabinet Group .....	A	Pulley, Belt and Motor Group .....	H
Detailed Illustration (Figure 5-1) .....	A	Detailed Illustration (Figure 5-8) .....	H
Control Housing .....	B	Bearing Housing Group .....	J
Detailed Illustration (Figure 5-2) .....	B	Detailed Illustration (Figure 5-9) .....	J
Electrical Control Group .....	C	Coin Group .....	K
Detailed Illustration (Figure 5-3) .....	C	Detailed Illustration (Figure 5-10) .....	K
Door Switch Group .....	D	Burner Housing and Gas Control Group .....	M
Detailed Illustration (Figure 5-4) .....	D	Detailed Illustration (Figure 5-11) .....	M
Damper and Damper Switch Group .....	E	Back Guard & Heat Rec. Group .....	N
Detailed Illustration (Figure 5-5) .....	E	Detailed Illustration (Figure 5-12) .....	N
Lint Hood and Screen Group .....	F	Wiring Group .....	5-16
Detailed Illustration (Figure 5-6) .....	F		
Tumbler Assembly Group .....	G		
Detailed Illustration (Figure 5-7) .....	G		

# Section 1

## Commercial Dryer

### PRIMARY SERVICE DATA

#### 1-1 UNCRATING

1. Remove cardboard container and innerpack.
2. Complete the uncrating as per the procedure listed on the instruction sheet taped to the loading door glass.

#### 1-2 EQUIPMENT INSTALLATION

**IT IS ABSOLUTELY ESSENTIAL THAT THE DRYER BE GROUNDED TO A KNOWN EARTH (ZERO) GROUND. THIS IS NOT ONLY FOR PERSONAL SAFETY, BUT IS NECESSARY FOR PROPER OPERATION OF THE CONTROLLER. FAILURE TO DO SO WILL VOID THE WARRANTY OF THE CONTROLLER.**

All commercial dryer installations should be made in accordance with National Fuel Gas Code ANSI-Z223.1-1980 and must be electrically grounded in accordance with the National Electrical Code ANSI/NFPA70-1981.

In addition, all requirements of the authority having jurisdiction in the area must be adhered to. For Canadian installation refer to Canadian Standards Association Standard CSA-C22.1 and standard CGA B149(.1 or .2 installation code for gas burning appliances.

Commercial dryers should be located where a minimum amount of exhaust venting is necessary. (See Exhausting).

A minimum of 10" unobstructed air space above the dryer is necessary for proper air supply to the dryer.

**Note ¼" clearance must be provided at top in front for clearance of upper service door opening.**

A false ceiling of lattice-work or perforations consisting of metal or nonflammable material can be used for installations. This arrangement allows hot ceiling air to be drawn into the dryers, which will make the occupied room air more comfortable and aid in drying efficiency.

Any partitions or bulkheads that might be used on dryer installations should be constructed completely of nonflammable material.

Adequate make-up air must be supplied to replace air exhausted by the dryers. Provide a minimum of one sq. ft. make-up air opening to the outside for each dryer.

The source of make-up air should be located sufficiently away from the dryers to allow an even air flow to the air intakes of all dryers.

Whenever it is necessary to supply make-up air through the ceiling or wall adjacent to the dryers, multiple openings should be provided. Additionally a deflector baffle or duct is recommended for these openings to disperse the air and allow even distribution of air flow over the dryers.

Locate the dryers out from the wall sufficiently to allow for servicing from the rear. (See Clearance Requirements).

All dryers should be level and resting solidly on the floor or foundation. This is accomplished by adjustment of the leveling legs provided with each dryer.

**NOTE:** The following considerations must be observed for gas dryer installations where dry cleaners are installed. The sources of all make-up air and room ventilation air movement to all dryers must be located away from any dry cleaners. This is necessary so solvent vapors will not be drawn into the dryer inlet ducts. Dry cleaner solvent vapors will decompose on contact with a open flame. The decomposition products are highly corrosive and will cause damage to dryers, ducts and clothes load.

### **1-3 ELECTRICAL REQUIREMENTS**

The electrical power requirements necessary to operate the unit satisfactorily are listed on the serial plate located on the back panel of each dryer. The electrical connection should be made at the pig tail leads provided at the service box outlet (or terminal block if supplied) on the rear of the unit, using a wire size adequate to handle the voltage listed on the serial plate but never smaller than No. 12. Additionally, separate lines should run to each unit with an overload protection device installed. A master control panel with an individual circuit breaker (15 amp.) for each unit is recommended.

The unit should be grounded in accordance with all local and national electrical codes. It is recommended the cabinet be grounded by means of the grounding wire used with three wire power supply cable. Secure one end of the cable ground wire to the cabinet and the other end can be secured to the supply outlet box if the box itself is grounded. Another method would be to securely ground the cabinet with a stranded wire secured to a physical ground such as a cold water pipe.

### **1-4 CLEARANCE REQUIREMENTS**

1. If dryer is installed in a confined space, a minimum opening of 144 sq. in. must be provided near the top of the dryer cabinet at the rear, in order to admit combustion and ventilation air.
2. A minimum of 24 in. clearance behind the dryer must be provided to permit maintenance and service.

#### **FOR YOUR SAFETY**

**Do not store or use gasoline or other flammable vapors or liquids in the vicinity of this or any other appliance. Consult your local Gas Supplier for procedure to be followed if the odor of gas is present.**

### **1-5 GAS REQUIREMENTS**

The complete gas requirements necessary to operate the various gas dryers satisfactorily are listed on the serial plate located on the back of each dryer.

The inlet gas pipe connection to the unit is ½ in. However, the local conditions of type and gas pressure, plus the number of fittings and length of pipe are considerations on the size of supply pipe to be used.

1. A joint compound resistant to the action of L.P. gases should be employed in making pipe connections.
2. A drip tee should be provided in the gas piping entering the unit to catch dirt and other foreign articles.
3. All pipe connections should be checked for leakage with soap solution. Never check with an open flame.

**NOTE: It is necessary that the local gas company be contacted for the correct size of pipe to be connected from the source to the inlet connection at the units. This information is necessary so the proper gas pressure may be maintained to the dryers.**

In the areas where permitted, it is suggested that flexible supply line be used from the main gas supply line to the inlet pipe connection at the dryer. This will allow moving the dryer forward to remove the front panel without disconnecting the gas supply line.

Many installations use a balancing line to insure adequate gas supply when bank of dryers are to be installed from a manifold type of gas supply line. This arrangement helps to maintain adequate gas supply to all dryers no matter their location on the manifold take-off. The balancing line should be of a pipe diameter which will permit adequate gas supply through the manifold and is connected to each of the manifolds.

All commercial dryers shipped from the factory will be equipped with the main burner orifices drilled to a size to supply the correct B.T.U. per hour heat input as listed on the serial plate on the back panel of the dryer. These orifices will be drilled for use with natural gas of 1050 B.T.U.'s cu. ft., 0.60 specific gravity at 3½ in. water column gas pressure at the main burners.

**NOTE: It will be necessary to change main burner orifices to maintain the correct B.T.U. heat input/hour at 3½" water column gas pressure, when any dryer is to be used with gas which contains different characteristics of heat content and specific gravity than that as shown in the data on the back of dryer. Consult the local gas utility for the characteristics of the gas on which the dryer is to operate. The following charts should then be consulted for the correct main burner orifice drill size required. The charts are to be as guides and if your local conditions are not listed, your company can advise you of the proper orifice size. Be sure and inform them that two burners are used in the system.**

If the dryer is to be used on L.P. gas, a conversion kit is available to make the complete conversion. (See parts list section of the manual).

### HOW TO SELECT PROPER ORIFICE SIZE

Natural and Mixed Gases - Table I and II include data for selecting the proper orifice size for a required rate when the heating value, specific gravity, and gas pressure to be used are known. In using these tables a factor is first selected from Table I corresponding to the specific gravity and heating value of the gas supply being considered. This factor is then multiplied by the input rate of the burner in B.T.U. per hour. The proper orifice size may then be selected from Table II by locating the resultant input rate under the desired pressure.

EXAMPLE: Given: Gas condition of 1000 B.T.U./cu. ft., 0.6 specific gravity and 3 in. water column pressure.

Wanted: Drill size for 50,000 B.T.U./burner

In Table I a multiplier of .800 is found ( $.800 \times 50,000 = 40,000$  BTU)

In Table II 40,000 BTU is in between a No. 26 and No. 27 drill size.

TABLE 1

## ORIFICE CAPACITIES

Correction for heating value and specific gravity of gas

(Basic-800 BTU-0.6 Sp. Gr. Gas)

SPECIFIC GRAVITY (AIR=1.0)

HEATING VALUE BTU/cu. ft.	0.3	0.4	0.5	0.6	0.7	0.8	0.9	1.0	1.1	1.2	1.3	1.4
400	1.41	1.63	1.83	2.00	2.16	2.31	2.45	2.59	2.70	2.83	2.95	3.06
500	1.13	1.31	1.46	1.60	1.73	1.85	1.96	2.07	2.16	2.27	2.36	2.45
525	1.08	1.29	1.39	1.52	1.64	1.76	1.87	1.97	2.06	2.16	2.25	2.33
550	1.03	1.24	1.33	1.45	1.57	1.68	1.78	1.88	1.97	2.06	2.15	2.23
575	0.983	1.14	1.27	1.39	1.50	1.61	1.70	1.80	1.88	1.97	2.05	2.13
600	0.942	1.04	1.22	1.33	1.44	1.54	1.63	1.73	1.80	1.89	1.97	2.04
700	0.810	0.932	1.04	1.12	1.24	1.32	1.39	1.48	1.54	1.62	1.69	1.75
800	0.707	0.816	0.912	1.00	1.08	1.15	1.22	1.30	1.35	1.41	1.48	1.53
825	0.685	0.791	0.885	0.970	1.05	1.12	1.19	1.26	1.31	1.37	1.43	1.48
850	0.665	0.769	0.860	0.942	1.02	1.09	1.15	1.22	1.27	1.33	1.39	1.44
875	0.646	0.746	0.835	0.915	0.987	1.05	1.12	1.19	1.24	1.29	1.35	1.40
900	0.628	0.725	0.811	0.890	0.960	1.03	1.09	1.15	1.20	1.26	1.31	1.36
950	0.595	0.687	0.769	0.842	0.910	0.972	1.03	1.09	1.14	1.19	1.24	1.29
1000	0.565	0.653	0.730	0.800	0.864	0.924	0.980	1.04	1.08	1.14	1.18	1.22
1025	0.551	0.636	0.712	0.781	0.842	0.900	0.955	1.01	1.06	1.10	1.15	1.19
1050	0.538	0.621	0.696	0.762	0.823	0.800	0.934	0.985	1.03	1.08	1.12	1.16
1075	0.526	0.606	0.679	0.745	0.804	0.859	0.911	0.961	1.00	1.05	1.10	1.14
1100	0.514	0.594	0.664	0.727	0.785	0.840	0.891	0.938	0.982	1.03	1.07	1.11

TABLE II

## ORIFICE CAPACITIES IN BTU/HR

(800 BTU-.06 SP. GR. GAS

(See Table I for corrections to apply for other gases)

GAS PRESURE IN INCHES (Water Column)

ORIFICE SIZE	DEC. DIM.	3"	4"	ORIFICE SIZE	DEC. DIM.	3"	4"
16	.177	58,000	66,900	31	.120	26,700	30,950
17	.173	55,500	64,000	32	.116	24,950	28,900
18	.1695	53,300	61,500	33	.113	23,700	27,450
19	.166	51,000	58,800	34	.111	22,800	26,400
20	.161	48,000	55,400	35	.110	22,400	26,000
21	.159	46,700	53,900	36	.1065	21,000	24,300
22	.157	45,600	52,600	37	.104	20,000	23,200
23	.154	44,000	50,700	38	.1015	19,080	22,100
24	.152	42,700	49,300	39	.0995	18,300	21,200
25	.1495	41,400	48,000	40	.098	17,800	20,600
26	.147	40,100	46,500	41	.096	17,100	19,800
27	.144	38,500	44,600	42	.0935	16,200	18,800
28	.1405	36,600	42,400	43	.089	14,700	17,000
29	.136	34,300	39,700	44	.086	13,730	15,900
30	.1285	30,800	35,700	45	.082	12,450	14,400

## 1-6 MAIN BURNER ADJUSTMENT

The primary air shutter of each main burner must be properly adjusted for the correct air-gas ratio. Adjust the shutter by closing it sufficiently to give a blue flame with a yellow tip. Next open the shutter until the yellow tips are at a minimum. Securely lock the shutter in position by tightening the screw after adjusting the shutter.

## 1-7 EXHAUSTING

Exhausting of the dryer(s) should be planned and constructed so that no air restrictions occur. Any restriction due to pipe size or type of installation can cause slow drying time, excessive heat, and lint in the room.

From an operational stand-point, incorrect or inadequate exhausting can cause a cycling of the high limit thermostat which shuts off the main burners and results in inefficient drying.

Individual exhausting of the dryers is recommended. All heat, moisture, and lint should be exhausted outside by attaching a pipe of the proper diameter to the dryer adapter collar and extending it out through an outside wall. This pipe must be very smooth on the inside, as rough surfaces tend to collect lint which will eventually clog the duct and prevent the dryer from exhausting properly. All elbows must be smooth on the inside. All joints must be made so the exhaust end of the pipe is inside the next one downstream. The addition of an exhaust pipe tends to reduce the amount of air the blower can exhaust. This does not affect the dryer operation if held within practical limits. For the most efficient operation, it is recommended that no more than 20 feet of straight 8" diameter pipe be used with two right angle elbows. When more than two elbows are used, two feet of straight pipe should be removed for each additional elbow. No more than four right angle elbows should be used to exhaust a dryer.

If the exhaust pipe passes through a wall, a metal sleeve of slightly larger diameter should be set in a wall and the exhaust pipe passed through this sleeve. This practice is required by some local codes and is recommended in all cases to protect the wall.

This type of installation should have a means provided to prevent rain and high winds from entering the exhaust when the dryer is not in use. A hood with a hinged damper can be used for this purpose. Another method would be to point the outlet end of the pipe downward to prevent entrance of wind and rain. In either case, the outlet should be kept clear of any objects by at least 24" which would cause an air restriction.

Never install a protective screen over the exhaust outlet.

When exhausting a dryer straight up through a roof, the overall length of the duct has the same limits as exhausting through the wall. A rain cap must be placed on top of the exhaust and must be of such a type as to be free from clogging. The type using a cone shaped "roof" over the pipes is suitable for this application.

Exhausting the dryer into a chimney is not recommended under any conditions even though the chimney is being used for other exhausting. Neither is exhausting under a building recommended. In both cases, there is danger of build-up of fine lint over a period of time.

Installation of several dryers where a main discharge is necessary, will need the following considerations for installation (See Fig. 1-1). Individual 8" ducts from the dryers into the main discharge duct should be at a 45° angle in the direction of discharge air flow.

**NOTE:** Never install the individual 8" ducts at a right angle into the main discharge duct. The individual ducts from the dryers can enter at the sides or bottom of the main discharge duct. Figure 1-1 indicates the various round main duct diameter to use with the individual dryer ducts. The main duct can be rectangular or round, provided adequate air flow is maintained. For each individual dryer, the total exhausting (main discharge duct plus duct outlet from the dryer) should not exceed the equivalent 20 feet and two elbows. The diameter of the main discharge duct at the last dryer must be maintained to exhaust end.

**NOTE:** A small diameter will restrict air flow; a larger diameter will reduce air velocity — both contributing to lint build up. Inspection door for periodic clean-out of the main duct should be provided.

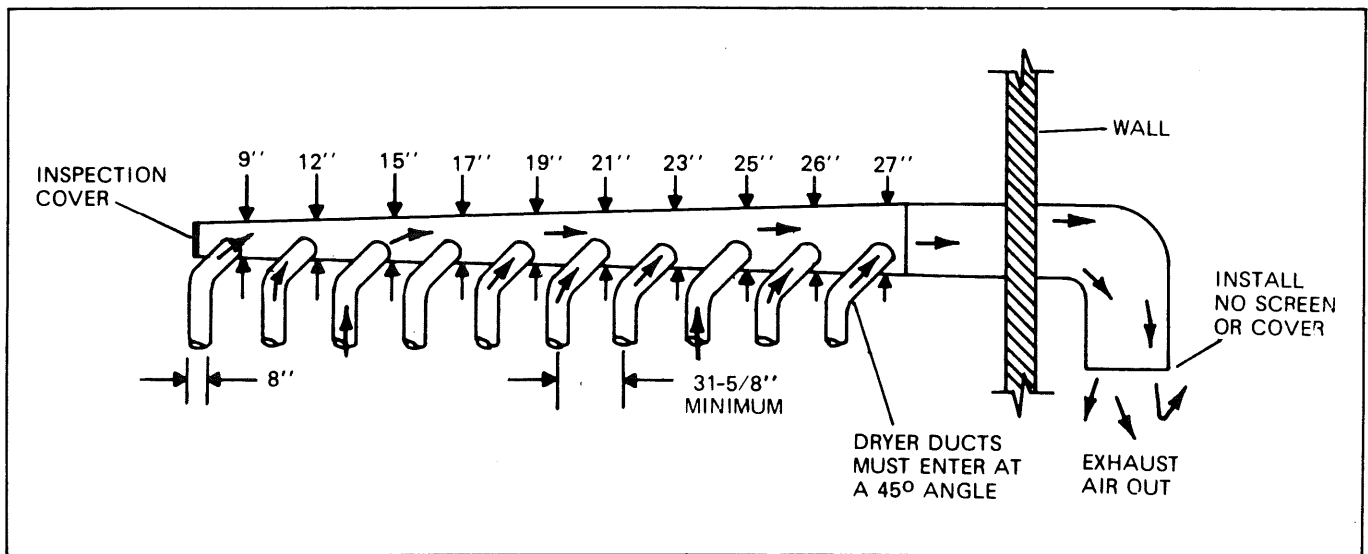

Figure 1-1. Dryer Exhausting Using A Main Discharge Duct

## 1-8 ELECTRONIC DRYER CONTROL COMPONENT DESCRIPTION

The electronic dryer control system consists of three parts; a printed circuit board assembly with a vacuum fluorescent display and three LED program indicator lights, a 12-button membrane-switch keypad assembly, and a temperature sensor.

The keypad assembly has a self-adhesive back and is mounted to a controls mounting plate. The printed circuit board is mounted to the opposite side of the plate in such a position that the display on the circuit board shows through the window of the keypad.

The temperature sensor is mounted in the airstream directly below the clothes cylinder. A lead wire from the sensor is plugged into the printed circuit board.

The electronic dryer control system operates the drive motor and the gas valve system.

It receives signals from coin switches on the coin acceptors, it credits drying time for coin signals received, it displays vend price and cycle time, and indicates which one of three cycle temperatures is engaged.

Authorized individuals may re-program the control system with different control data and parameters by direct keyboard data input. All control data is stored in a non-volatile memory.

The dryer is programmed at the factory with settings that may be satisfactory for many users. These settings are given in the Programming Instructions. They allow the dryer to be installed and run for checkout even if the owner desires to later change some of the operating values.

## 1-9 WARNINGS ABOUT USE AND OPERATION



**A dryer should be connected to power for three (3) minutes before it is operated or before a program change is made.** Operation or program changes which occur during this "power up" period are subject to loss in case of power interruption. After the initial three minutes, all programmed data is protected from power interruptions of any length and the customer's individual cycle is protected up to three (3) seconds. This is done without any batteries.

Leave the electrical power to the dryers on at all times except when necessary for service or other similar activities. The hourmeter function adds only full hours to its readings. If the power is shut off every night, the fraction of an hour of time that happens to be on the machine at that time will be lost.

From a safety aspect shutting off the gas supply at night would be better than shutting off the electrical power.

**NOTE: It is absolutely essential that the dryer be grounded to a known earth (zero) ground. This is not only for personal safety, but is necessary for proper operation of the controller. Failure to do so will void the warranty of the controller.**

## 1-10 OPERATING INSTRUCTIONS

- 1 Deposit coins to satisfy vend price display of idle dryer. Each deposit decreases vend price until display changes to show time purchased. WARM light illuminates.
2. Select drying cycle.  
Other cycle selections may be made now or later by pressing the appropriate key (button).
3. Close the loading door. Press  and the dryer will start. "Seconds" goes to . "Minutes" is rounded up and will count down each minute. The colon flashes on and off indicating the timer is counting down.
4. Clothes should be removed promptly after the cycle is completed to prevent excessive wrinkling.

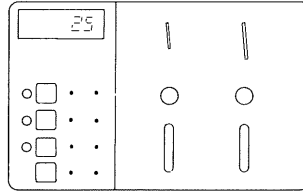

VEND PRICE

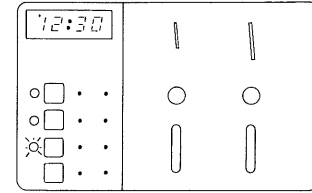

MINUTES : SECONDS  
PURCHASED

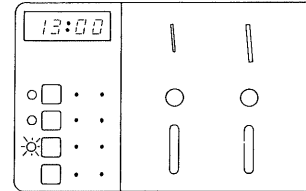

START

Once started, the "timer" cannot be stopped. However, extra coins will be acknowledged by adding time to the display. The dryer may be stopped by opening the loading door which interrupts the drive motor and gas burners. Close the loading door and push  to restart the dryer.

Cool down time (owner programmable) is always part of the cycle time and is purchased by the customer. For example, if cool-down time is 2 minutes, the last 2 minutes of the cycle will have no heat.

## 1-11 PROGRAMMING INSTRUCTIONS

Almost all operating parameters (vend price, temperatures, cool-down times, etc.) are adjustable. In addition, several displays of information are available from the controller. (coin audits, hourmeter, temperature readings).

The dryer is ready to run, from the factory, with the following pre-programmed data:

Vend Price	25 (cents)
Time for Left Coin:	5:00 (5 minutes, 0 seconds for a dime) (doesn't apply to single-coin models)
Time for Right Coin:	12:30 (12 minutes, 30 sec. for a quarter)
Time of Free Vend:	10:00 ("Free Dry" cycle is 10 minutes)
Cool-down Time, HOT:	2:00 (Cool-down time in HOT is 2 minutes)
Cool-down Time, PERM PRESS:	2:00 (Same as above, except PERM PRESS)
Cool-down Time, WARM:	2:00 (Same as above, except WARM)
Temperature, HOT:	175 (degrees F)
Temperature, PERM PRESS:	150 (degrees F)
Temperature, WARM	125 (degrees F)

All of the above data can be easily changed by the owner. The changes are made by direct keyboard entry, as simply as one uses a pocket calculator.

# PROGRAMMING INSTRUCTIONS:

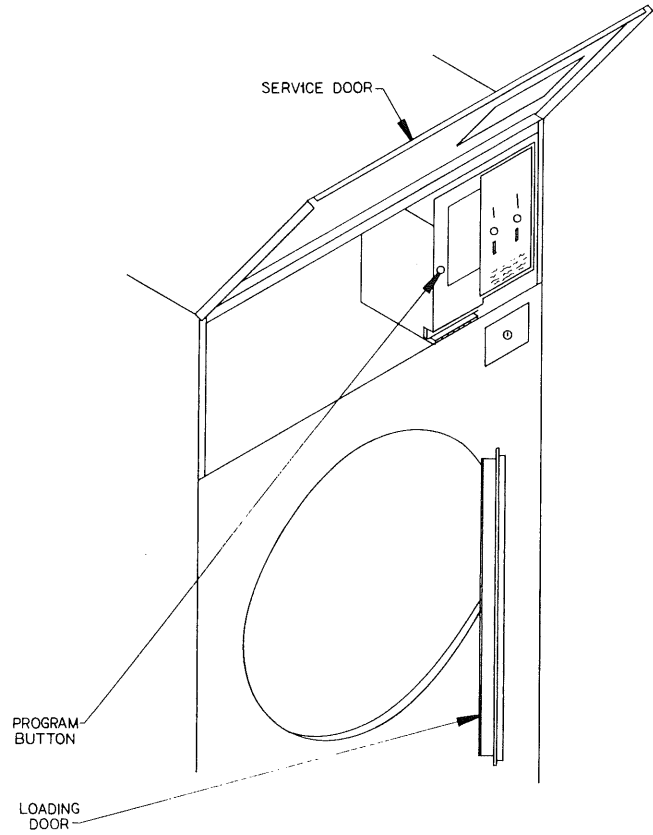

## SELECTING PROGRAM MODE

1. Unlock and open the upper service door.
2. Open the loading door.
3. Locate and remove the plug button found just to the left of the "WARM" cycle light. Push the program button now exposed through the hole in the control mounting plate.
4. The controller switches to PROGRAM mode. In PROGRAM mode, the entire membrane switch keypad becomes energized and behaves like a pocket calculator or a pushbutton telephone keypad.
5. The ACTUAL NUMERICAL VALUES desired are keyed in as explained on page 1-11.

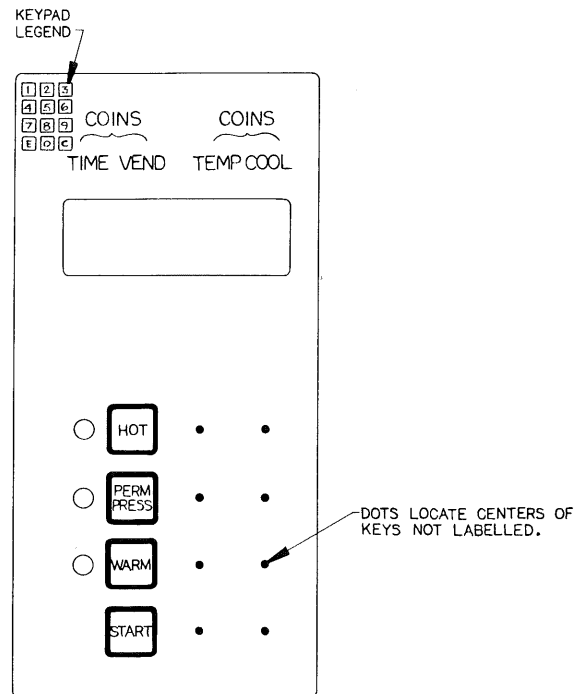
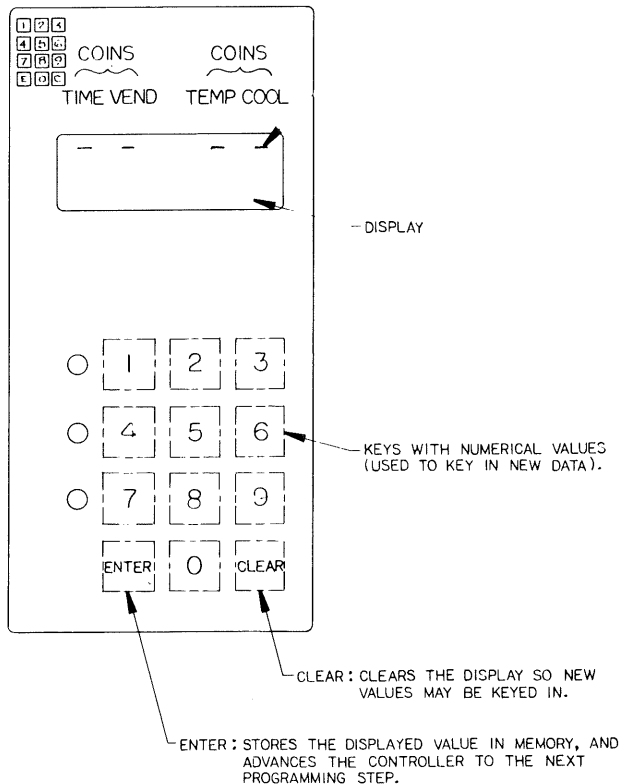

ANNUNCIATOR LIGHTS WHICH HELP IDENTIFY PROGRAMMING STEPS









**IMPORTANT:** Please remember to push  to actually enter (store in memory) new data. If you merely change the display, memory hasn't yet been changed — only  will actually change the memory!

# ORDER OF INDIVIDUAL PROGRAMMING STEPS WITHIN THE CONTROLLER

CYCLE LIGHTS	DISPLAY	PROGRAMMING STEP	DESCRIPTION	OPTIONS/RANGE OF LIMITS
H PP W	---	LEFT COIN AUDIT	Coin counter - number of coins deposited through coin acceptor on left side (dual coin models only)	May be set to zero
H PP W	---	RIGHT COIN AUDIT	Coin counter - number of coins deposited through coin acceptor on right side (all models)	May be reset to zero
		HOURLMETER	Displays hours of "timer" operation	Cannot be adjusted
	-	VEND PRICE	Money required to start the dryer	00 through 9999 (cents) (00 causes "Free Vend")
	---	TIME FOR LEFT COIN	Minutes and seconds awarded for one coin deposited through the left coin acceptor (dual coin models)	00 through 99 min: 59 sec.
	---	TIME FOR RIGHT COIN	Minutes and seconds awarded for one coin deposited through the right coin acceptor (all models)	00 through 99 min: 59 sec.
	---	TIME OF FREE VEND	Minutes and seconds of "Free" dry (if "Free" Dry feature is used — see vend price above)	00 through 99 min: 59 sec.
H	---	COOL-DOWN TIME; HOT	Minutes and seconds of cool-down; Hot cycle	00 through 99 min: 59 sec.
PP	---	COOL-DOWN TIME; PERM PRESS	Minutes and seconds of cool-down; Perm Press cycle	00 through 99 min: 59 sec.
W	---	COOL-DOWN TIME; WARM	Minutes and seconds of cool-down; Warm cycle	00 through 99 min: 59 sec.
H	---	TEMPERATURE; HOT	Heat shut-off temperature limit; Hot cycle	150 - 199 (degrees F)
PP	---	TEMPERATURE; PERM PRESS	Heat shut-off temperature limit; Perm Press cycle	120 - 170 (degrees F)
W	---	TEMPERATURE; WARM	Heat shut-off temperature limit; Warm cycle	110 - 150 (degrees F)
	---	LEFT COIN VALUE	Value of coin deposited through left acceptor (dual coin models) Usually 10¢ - Dime	Must be value of coins through left acceptor
	---	RIGHT COIN VALUE	Value of coin deposited through right acceptor (all models) Usually 25¢ - Quarter	Must be value of coins through right acceptor

## CHANGING PROGRAM DATA

1. Switch to PROGRAM mode as explained on page 1-9.
2. Go to the programming step to be changed by repeatedly pushing . Program steps may be identified by the display and light combinations as shown on page 1-10.
3. Press "CLEAR" to clear display.
4. Key in the new data just as if you were using a pocket calculator. For example, 17 minutes and 5 seconds would be keyed in with this sequence: . The display will change with each keystroke.
5. Then, be sure to press . That will store the display value in memory and advance the controller to the next program step.
6. You may continue re-programming by repeating steps 2 through 5. Or, you may return to "RUN" mode by any of the following steps:
  - A. "Stepping" through the remainder of the programming sequence by repeatedly pressing "Enter" allows you to skip over steps without changing them.
  - B. Pushing the Program Button again.
  - C. Closing the loading door.

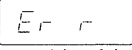
Attempts to enter erroneous data will result in an error display . If you get such a display, simply "CLEAR" the display and re-enter valid data. Erroneous data are temperatures outside of the cycle limits, and a number greater than 59 in the "seconds" position when entering values of time.

During dryer operation, the temperature sensed by the temperature probe may be displayed by pushing the keypad dot found to the far right of the "START" key. That dot becomes the "CLEAR" key in PROGRAM mode. The display, as well as the controller itself, operates on 5 degree increments. By pushing and holding that dot, the existing display is overridden by the temperature display. However, the temperature display will not update as long as the key is held, even through the actual temperature may be changing.

As a safety precaution, the controller will automatically return to "RUN" mode after about 1-½ minutes of keyboard inactivity when in "PROGRAM" mode. This is to prevent a dryer from being abandoned in "PROGRAM" mode.

The controller memory always retains existing valid data until new valid data is ENTERED. Thus, a controller cannot be abandoned in an inoperative condition. For example, if a dryer was returned to RUN mode when an error display was showing, the dryer would continue operating on the last valid data it had used, which was still in memory.

Temperature values programmed by the factory have been selected to give good results of efficiency in drying time, and fabric care. For best operational accuracy, temperature values should end with "0" or "5".

Essentially, there are no restrictions placed on "Timer-per-Coin" data; however, the data must be realistic, especially for dual-coin dryers. Dual-coin dryers should have the same price/time ratio for each coin. Although customers may accept unequal ratios such as 5 minutes/10¢ and 15 minutes/25¢, they may complain about ratios more disproportionate.

The following chart is provided as a guide. It shows the correct time-per-coin data for a dual-coin (10¢/25¢) acceptor over a wide range, from \$0.20 to \$6.00 per hour of drying time. The time/price ratios are exact; i.e., the time shown for 25¢ is exactly 2-½ times that for 10¢.

### MINUTES: SECONDS PER COIN COMBINATIONS

TIME FOR 10¢	TIME FOR 25¢	CENTS PER HOUR	TIME FOR 10¢	TIME FOR 25¢	CENTS PER HOUR	TIME FOR 10¢	TIME FOR 25¢	CENTS PER HOUR
1:00	2:30	600	6:40	16:40	90	13:30	33:45	44.4
1:10	2:55	514.3	6:50	17:05	87.8	14:00	35:00	42.9
1:20	3:20	450	7:00	17:30	85.7	14:30	36:15	41.4
1:30	3:45	400	7:10	17:55	83.7	15:00	37:30	40
1:40	4:10	360	7:20	18:20	81.8	15:30	38:45	38.7
1:50	4:35	327.3	7:30	18:45	80	16:00	40:00	37.5
2:00	5:00	300	7:40	19:10	78.3	16:30	41:15	36.4
2:10	5:25	276.9	7:50	19:35	76.6	17:00	42:30	35.3
2:20	5:50	257.1	8:00	20:00	75	17:30	43:45	34.3
2:30	6:15	240	8:10	20:25	73.5	18:00	45:00	33.3
2:40	6:40	225	8:20	20:50	72	18:30	46:15	32.4
2:50	7:05	211.8	8:30	21:15	70.6	19:00	47:30	31.6
3:00	7:30	200	8:40	21:40	69.2	19:30	48:45	30.8
3:10	7:55	189.5	8:50	22:05	67.9	20:00	50:00	30
3:20	8:20	180	9:00	22:30	66.7	20:30	51:15	29.3
3:30	8:45	171.4	9:10	22:55	65.5	21:00	52:30	28.6
3:40	9:10	163.6	9:20	23:20	64.3	21:30	53:45	27.9
3:50	9:35	156.5	9:30	23:45	63.2	22:00	55:00	27.3
4:00	10:00	150	9:40	24:10	62.1	22:30	56:15	26.7
4:10	10:25	144	9:50	24:35	61.0	23:00	57:30	26.1
4:20	10:50	138.5	10:00	25:00	60	23:30	58:45	25.5
4:30	11:15	133.3	10:10	25:25	59.0	24:00	60:00	25
4:40	11:40	128.6	10:20	25:50	58.1	24:30	61:15	24.5
4:50	12:05	124.1	10:30	26:15	57.1	25:00	62:30	24
5:00	12:30	120	10:40	26:40	56.2	25:30	63:45	23.5
5:10	12:55	116.1	10:50	27:05	55.4	26:00	65:00	23.1
5:20	13:20	112.5	11:00	27:30	54.4	26:30	66:15	22.6
5:30	13:45	109.1	11:10	27:55	53.7	27:00	67:30	22.2
5:40	14:10	105.9	11:20	28:20	52.9	27:30	68:45	21.8
5:50	14:35	102.9	11:30	28:45	52.2	28:00	70:00	21.4
6:00	15:00	100	11:40	29:10	51.4	28:30	71:15	21.1
6:10	15:25	97.3	12:00	30:00	50	29:00	72:30	20.7
6:20	15:50	94.7	12:30	31:15	48	29:30	73:45	20.3
6:30	16:15	92.3	13:00	32:30	46.2	30:00	75:00	20

## 1-12 TEMPERATURE READOUT FEATURE

A temperature display is provided as one function of the controller. This display may be forced anytime the dryer is not in the programming mode, whether the dryer is running or idle. The temperature display is called by pushing the dot farthest to the right of the "start" button. The temperature displayed is that being measured by the temperature sensor located in the air stream below the cyclinder. The temperature displayed will remain the same until the button is released even if the actual temperature is changing. All temperatures displayed will be in 5 degree increments due to controller design.

## 1-13 TEMPERATURE SETTINGS

As given in the programming steps listed previously the following temperatures are allowed for each temperature setting:

Hot	150-199 degrees F
Perm Press	120-170 degrees F
Warm	110-150 degrees F

As received from the factory the dryer is programmed with the following temperature for each temperature setting:

Hot	175 degrees F
Perm Press	150 degrees F
Warm	125 degrees F

These temperatures have been determined to give the same drying performance as previous Dexter 30# thermostatically controlled dryers. The programmed temperatures shown above may not agree with temperature recommendations for previous dryers due to the difference in response times of the different types of systems. The temperatures measured and displayed by the dryer may also differ from those you have measured on previous dryers using different types of measuring equipment.

Raising drying temperatures will typically shorten drying times while increasing gas usage. Lowering temperatures will normally have the opposite result.

**CAUTION** - Increasing the programmed values of the temperature selections too much could cause damage to some fabrics. Any changes should be made in small trial steps.

# SPECIFICATIONS

## MODEL DDH3 SERIES

DDH3 Direct Ignition with Heat Reclaimer and Electronic control, 120 V. - 60 Cy.

### SUFFIX LETTERS DENOTING COIN METER:

EQ — 25¢  
EDQ — Dual 10¢/25¢

### SUFFIX LETTERS DENOTING COLOR:

No Suffix — White	A — Almond
HG — Harvest Gold	BO — Burnt Orange
S — Sand	

**NOTE: Above models adaptable to Natural or L.P. Gas.**

CAPACITY: 30 pounds of clothes - dry wgt.

AIR MOVEMENT: 815 C.F.M.

CYLINDER SPEED: 47 R.P.M.

MOTOR: ½ H.P.—ball bearings, capacitor start, thermally protected.

AIR TEMPERATURES: May be set within given ranges

HOT—150°-199° F. PERM PRESS—120°-170° F. WARM—110°-150° F.

COOL DOWN: Fully adjustable for each temperature setting.

GAS REQUIREMENTS: 90,000 B.T.U. /Hr. 3.5 in. of water column pressure for Natural Gas, and 11.0 in. water column for L.P. Gas.

WEIGHT: 495 lbs. Crated.

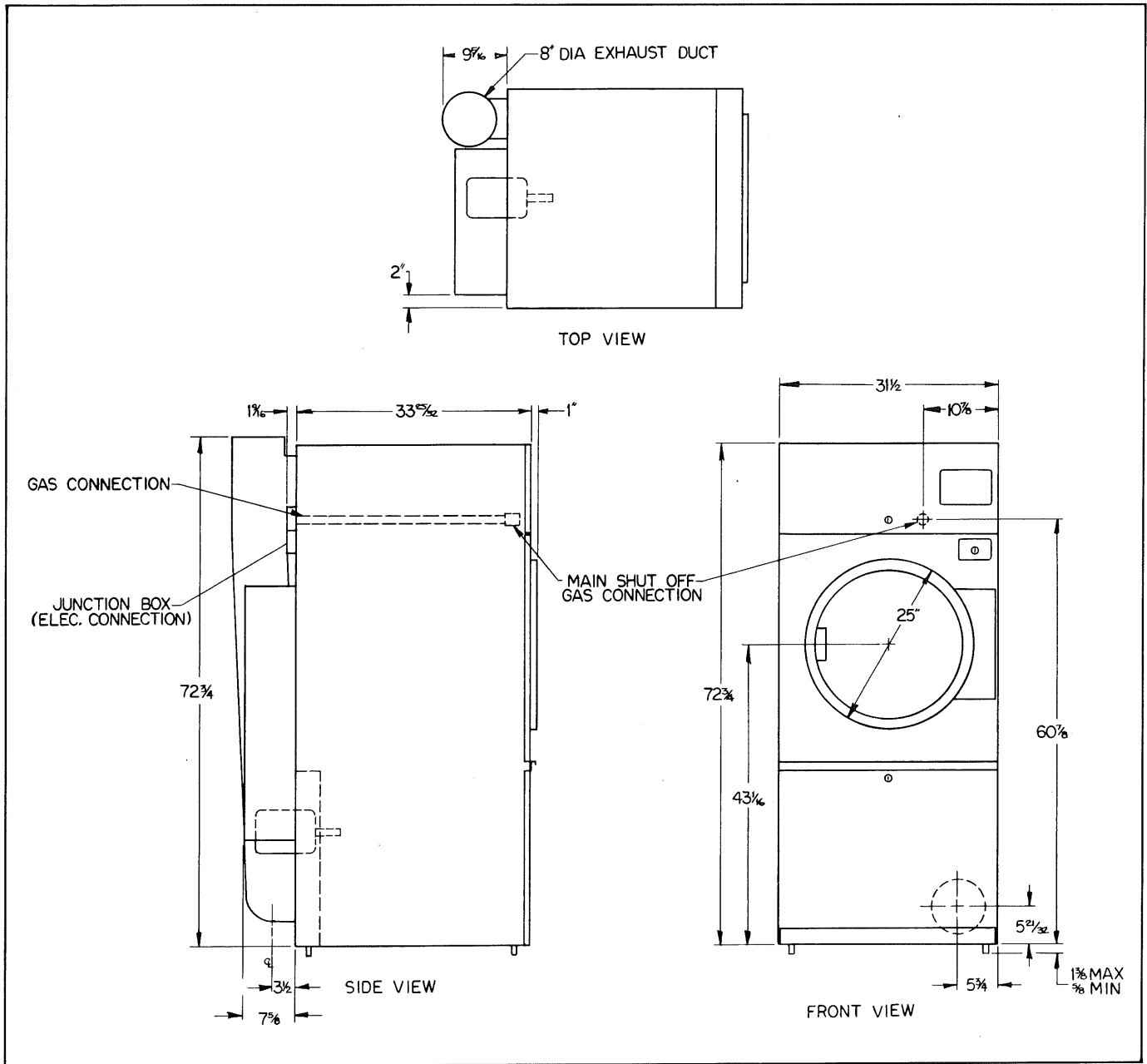
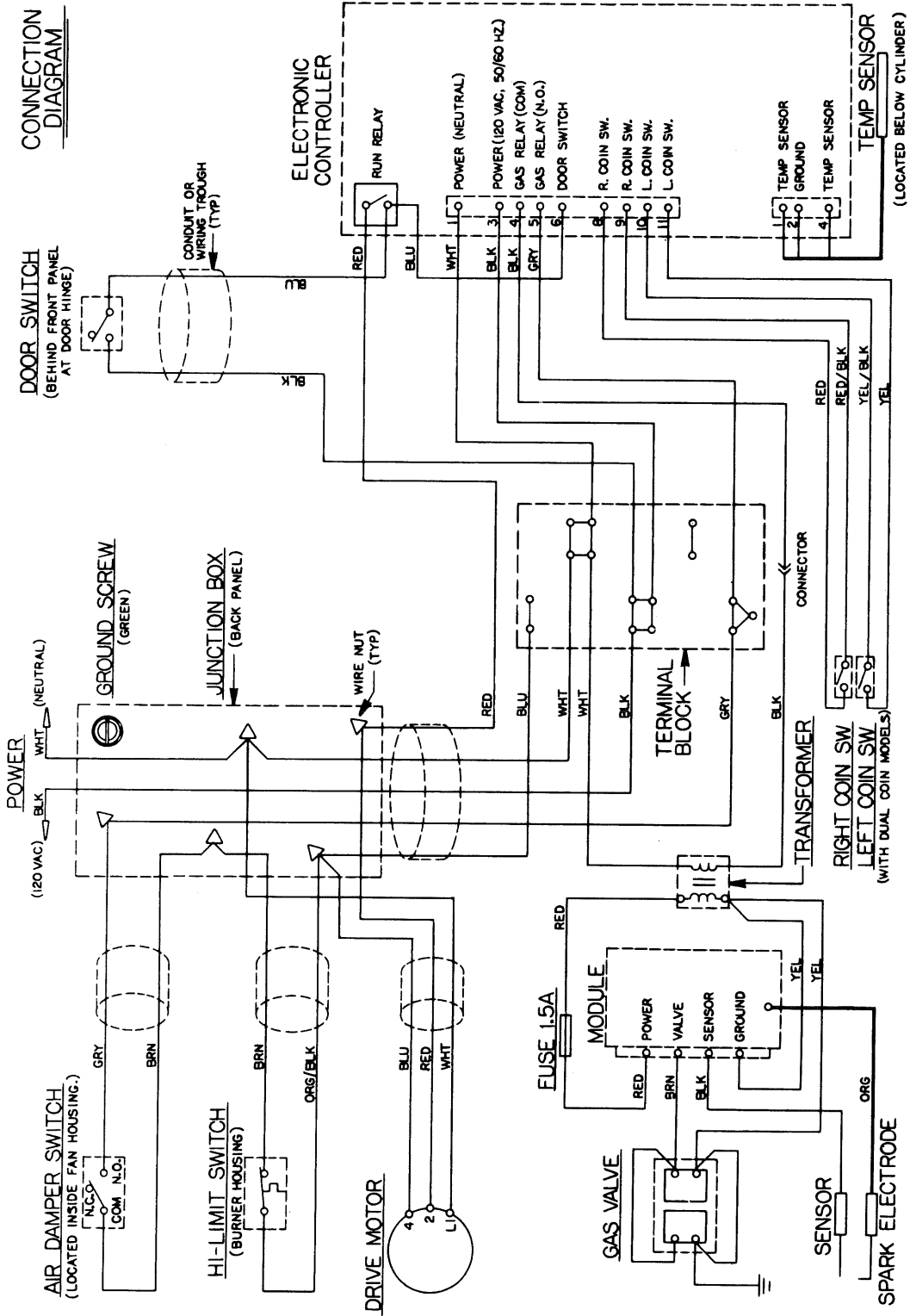

Figure 1-2. Dimensions

**WIRING DIAGRAM - Fig. 2-1**



# **Section 3**

## **SERVICE PROCEDURE**

### **Model DDH3 Series**

#### **3-1 UPPER SERVICE DOOR REMOVAL**

1. Insert key and unlock. Pull door out from bottom and lift to horizontal position. Swing door support wire until it engages with front lip of door and holds it in the raised position.
2. Drive the center pins out of the hinge (1 on each side) and retain the pins.
3. Pry the hinges carefully from the door and cabinet.

#### **3-2 COIN ACCEPTOR REMOVAL**

The coin meter is located behind the right side of the upper service door. (Two acceptors in the case of dual coin machines.)

1. Open the upper service door.
2. Remove the screw which holds the control panel closed (located close to the top center of the panel).
3. The control panel will swing down to rest on its rubber bumpers.
4. Remove three screws that mount the acceptor to the panel.
5. The coin return button and its retainer may be removed if necessary by removing one additional screw. (Keep this screw separate from others as it is of different length.)
6. Remove the two wires from the acceptor.

NOTE: For dual coin machines steps 4, 5, and 6 must be completed for each acceptor and the acceptors must be reassembled with the 10¢ acceptor on the left.

### 3-3 ELECTRONIC CONTROL REMOVAL

**CAUTION - AS WITH ALL ELECTRONIC CONTROLS THIS CONTROL MAY BE DAMAGED OR RUINED BY STATIC ELECTRICITY. OBSERVE THESE CAUTIONS WHEN WORKING WITH THE ELECTRONIC CONTROLS.**

- A. ALWAYS HANDLE CONTROLS STRICTLY BY THE EDGES OF THE CIRCUIT BOARD.**
- B. NEVER TOUCH A CONTROL IN A MACHINE WITHOUT TOUCHING THE CABINET OF THE MACHINE FIRST TO GROUND YOURSELF TO THE MACHINE.**
- C. WHEN SHIPPED INDIVIDUALLY, CONTROLS ARE WRAPPED IN AN ANTI-STATIC WRAP. WHEN REMOVING A CONTROL FROM A CARTON ALWAYS HANDLE IT BY THE ANTI-STATIC WRAP. DO NOT REMOVE THE WRAP UNTIL YOU HAVE GROUNDED YOURSELF TO THE MACHINE YOU ARE INSTALLING THE CONTROL IN.**

The electronic control is located behind the right side of the upper service door.

1. Open the upper service door.
2. Remove the screw which holds the control panel closed (located close to the top center of the control panel).
3. Swing the control panel down to rest on its rubber bumpers.
4. Remove the multiple wire connectors from the control.
5. Remove the six nuts that hold the electronic control. There is a lockwasher under one nut which must be reinstalled in the same position to ground the control.
6. The control may be lifted up a few inches to reveal the flat cable which connects the membrane switch to the control.
7. The flat cable is removed by firmly gripping the flat sides and pulling straight out of the connector. It is reinstalled by holding close to the end and pushing the cable all of the way into the connector.

### 3-4 MEMBRANE SWITCH REMOVAL

The membrane switch ass'y and the readout display window are one ass'y. They can not be reinstalled after removal.

1. First follow steps in 3-3 above for removal of the electronic control.
2. After the connection cable has been disconnected, the adhesive switch ass'y may be pried loose.
3. The adhesive area should be cleaned before installation of a new switch.
4. Switch assemblies must be positioned carefully as they cannot be removed once installed.

### 3-5 TEMPERATURE SENSOR CHECKOUT

If the temperature sensor becomes unplugged from the electronic control, the controller acts as if it sees a temperature of 199 degrees and will not allow the gas to come on. Therefore if the heat will not come on during a cycle, and the machine is cool but the temperature display feature shows 199 degrees the sensor may be unhooked or not functioning properly.

### **3-6 TEMPERATURE SENSOR REMOVAL**

1. Remove lower service door, lint screen and lint trap hood. (See 3-17).
2. Remove the sensor from the clip which holds it under the left baffle and slide it from the mounting grommet.
3. Remove the lead wire grommet from the back of the dryer and feed the sensor tube out through the hole.
4. Remove the sensor cable from the clips on the back of the machine and remove the cable grommet from the back of the control housing.
5. Open the upper service door and swing the electronic control down.
6. Remove the sensor cable connector from the electronic control.

### **3-7 CLOTHES DOOR POSITION ADJUSTMENT**

1. Open clothes door.
2. Loosen the four screws going through the hinge bracket enough to let the door move.
3. Then tighten the two center screws just enough to hold the door in position.
4. Move the door into desired position and retighten all of the screws.

### **3-8 CLOTHES DOOR LATCHING ADJUSTMENT**

1. Loosen the lock nut on the latching stud. It is located directly behind the door handle.
2. Open loading door.
3. Screw the door catch stud in or out as necessary and then retighten the lock nut.

### **3-9 CLOTHES DOOR REMOVAL**

1. The clothes door may be removed from the hinge bracket by unscrewing and removing the round headed pivot screw located at the door hinge point.
2. Then lean the door out of the top of the hinge bracket and lift the door from the bottom hinge pin.

### **3-10 CLOTHES DOOR HINGE BRACKET REMOVAL**

1. Remove the clothes door (3-9).
2. Remove the four screws going through the bracket into the front panel.

### **3-11 CLOTHES DOOR WINDOW AND GASKET REMOVAL**

1. Remove clothes door (3-9).
2. Block up the clothes door on a solid surface. Exert a pressure on the window circumference and push the window to free it from the gasket.

### **3-12 CLOTHES DOOR HANDLE REMOVAL**

1. Remove the two screws going through the left edge of the door into the handle.

### **3-13 INSTALLATION OF CLOTHES DOOR WINDOW AND GASKET**

1. Place clothes door, with its face down, on a solid surface.
2. Install the window gasket around the clothes door flange. The wider lip of the gasket should be on the bottom side or front face of the clothes door.
3. Install the door glass support into the gasket at the bottom of the clothes door.
4. Lay the window glass on the gasket. Apply a soapy water solution liberally around the circumference of the window.
5. Raise the gasket lip at its end over the glass with a blunt nosed tool. A 4" screwdriver shaft ground to a blunt point will serve this purpose.
6. Work the gasket lip over the glass around its circumference. While performing this operation keep the window positioned in the gasket. Apply the soapy water solution where necessary to facilitate this operation.
7. Finally, position the gasket with the palm of the hand to evenly distribute it around the window and clothes door.

### **3-14 DOOR SWITCH REMOVAL AND INSTALLATION**

1. The door switch is located directly behind the hinge plate of the loading door assembly. Remove the two screws holding the switch box cover in position. This will allow the removal of the cover and the switch actuator plate.
2. The entire switch box can now be pulled from the front panel opening, creating access to the door switch mounting screws.
3. Remove these two mounting screws and twin nut which frees the door switch and insulating shield. Remove wires.
4. When installing the door switch make certain the insulating shield is reassembled.
5. The actuator plate and switch box cover should be assembled as illustrated in Fig. 5-4.

### **3-15 LOWER SERVICE DOOR REMOVAL**

1. Insert the key and unlock door.
2. Pull top of door out from cabinet and lift to remove door from bottom pin slots.

### **3-16 FRONT PANEL REMOVAL**

1. Remove lower service door and raise upper service door, remove loading door.
2. Remove the two wires from the terminal block which go to the door switch. The wires are removed with the panel assembly.
3. Remove the two screws from sides, bottom and top of the front panel that secures it to the cabinet.

### **3-17 LINT SCREEN AND LINT TRAP HOOD REMOVAL**

1. Remove lower service door.
2. Slide lint screen up and out of screen guide angles (Refer figure 3-2).
3. Remove the six hex nuts that secure the lint trap hood to the blower housing assembly. Pull out to remove lint trap hood (Refer figure 3-3).

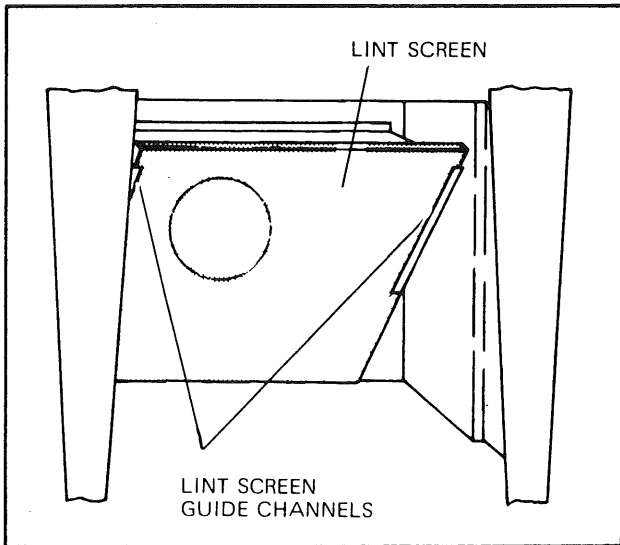

Figure 3-2. Lint Screen

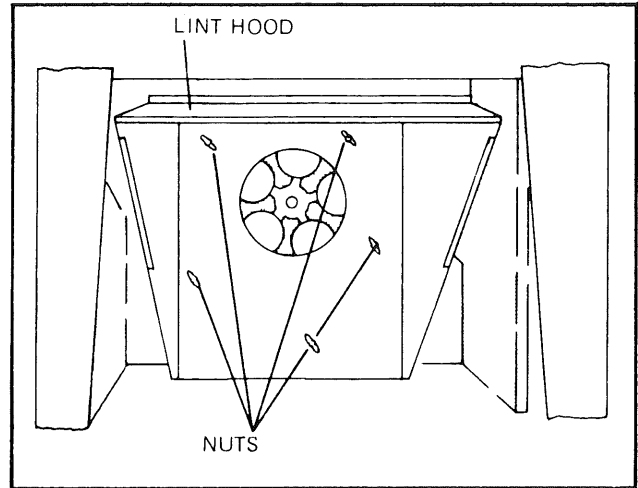

Figure 3-3. Lint Trap Hood

**3-18 BLOWER IMPELLER REMOVAL (Refer figure 3-4)**

1. Locate the two set screws in the impeller hub.
2. Attach a wheel puller behind the blades on the impeller hub, remove the impeller from the motor shaft. This method of removal is recommended to prevent any damage to the motor.

**3-19 DAMPER SWITCH REMOVAL AND ADJUSTMENT (Refer figure 3-5)**

1. Remove lower service door.
2. Remove lint screen and lint trap hood.
3. Remove switch shield by pulling out of slots.
4. Remove screws securing damper switch to bracket.
5. Adjust the damper switch by use of the adjusting screw in the switch arm so the switch operates when the damper is approximately 30° from the extreme up position.

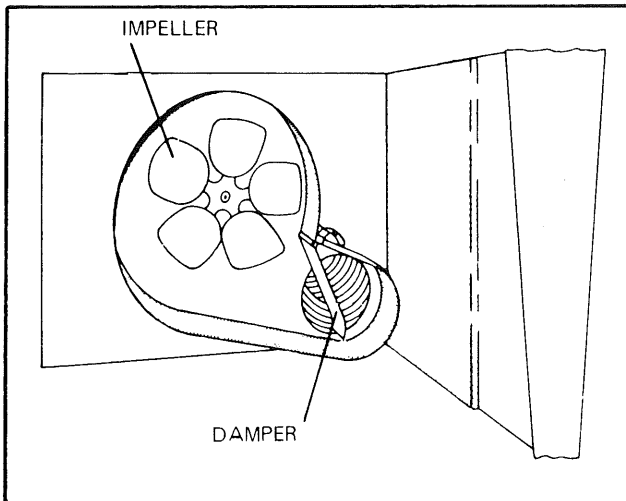

Figure 3-4. Blower Impeller

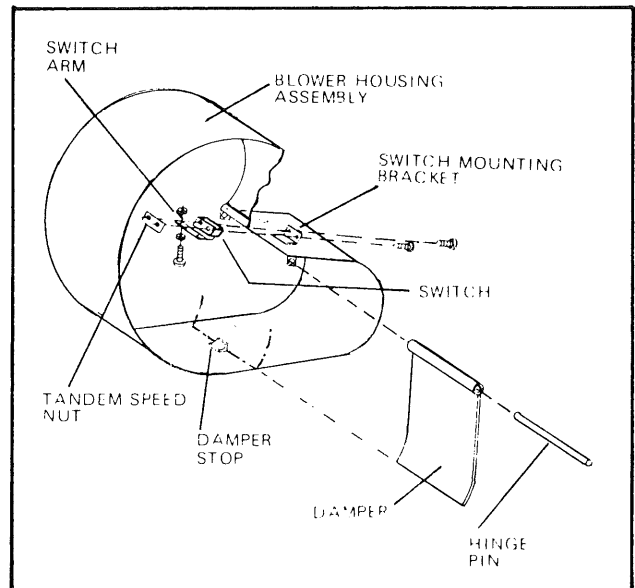

Figure 3-5. Damper Switch Assembly

### 3-20 HIGH LIMIT THERMOSTAT — FUNCTION & REMOVAL

The hi-limit thermostat is designed into the dryer to open the circuit to the main burners in the event of malfunction in the gas control area or control thermostat. The hi-limit opens at 300° F. and resets or closes at 250° F.

1. The thermostat is located on the upper left side of the burner housing. Remove the guard and wires connected to the hi-limit thermostat.
2. Remove the screws securing the thermostat to the bracket.

**NOTE:** Save spacers between the thermostat and bracket — use on reassembly.

### 3-21 GAS CONTROL VALVE ASSEMBLY

The redundant gas valve shown in Figure 3-8 includes two automatic coil operated valves, a pressure regulator and a shut-off valve, which in this application is a secondary shut-off valve. The primary or main shut-off valve should be used whenever servicing is required.

This gas valve assembly is controlled by the Electronic Module, and is convertible in the field from natural gas (3.5 in. w/c.) to liquefied petroleum gas (11.0 in. w/c.) setting. Refer to parts listing for L.P. Kit.

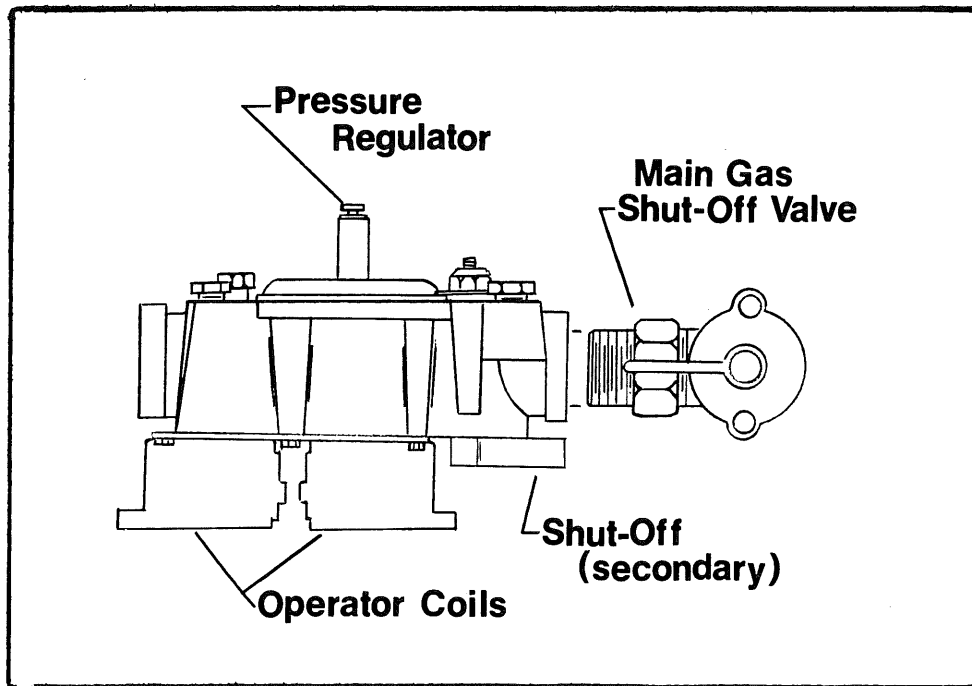
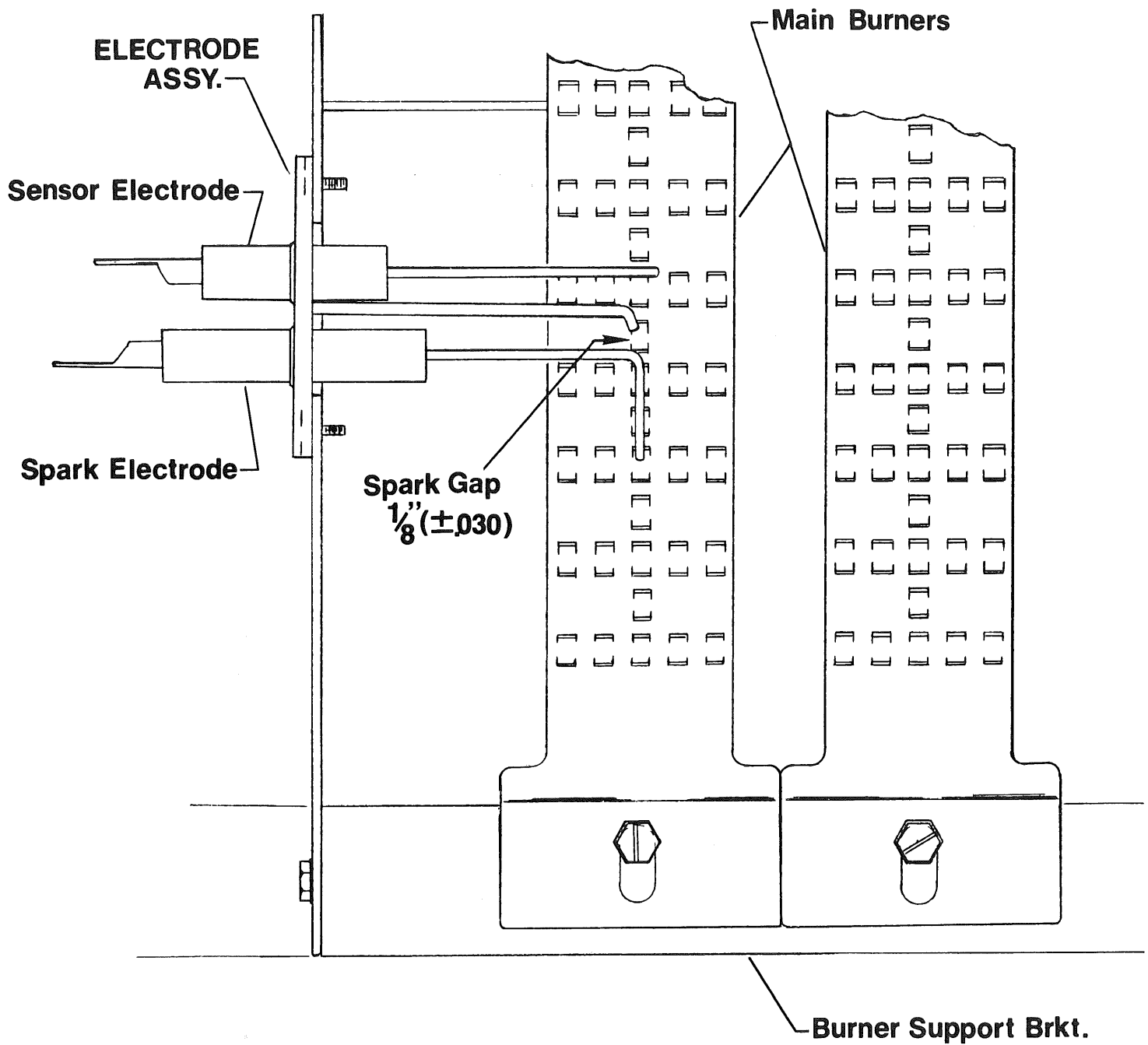

Figure 3-8. Gas Valve



**IMPORTANT:**  
 Electrodes are positioned  $3/8''$  above burner surface.  
 Electrode ends are centered to burner.

**Fig. 3-9**

### 3-22 ELECTRONIC IGNITION MODULE — FUNCTION

1. The electronic module (gray box) is located behind the upper service door, on top of the control housing.
2. The red wire from the transformer, thru the 1.5 amp fuse and into the module supplies the 24 volt current to operate the entire direct ignition system.
3. The orange colored hi-voltage wire (spark plug type) plugs onto the post connector on the module, and the multi-wire plug fits into the side of the module.

### 3-23 SPARK ELECTRODE ASSEMBLY—FUNCTION

1. The spark and sensing electrodes are located directly over the left side burner inside the burner housing.
2. The electrode with the orange hi-voltage wire conducts the spark to the center grounding probe, directly over the burner (See Figure 3-9)
3. The electrode with the black sensing wire detects ignition and monitors flame by signaling the module.

**NOTE: Proper grounding of the ignition system (yellow wires) is very critical for proper ignition sequence.**

### 3-24 IGNITION SYSTEM—FUNCTION & SEQUENCE

During normal dryer operation, the following occurs:

1. The dryer electronic control calls for heat.
2. Circuit is completed thru transformer and module (gray box) and power is applied to the gas valve and at the same time sparking occurs at the ignition electrode.
3. Once the flame is established, the sparking stops and the sensing electrode detects the presence of flame.
4. If for any reason the flame is not established in a period of 10 seconds, the gray box shuts down the sparking and closes the gas valve which is now in "Safety Lock-Out". Normally the 10 seconds "Trial For Ignition" period is ample in establishing proven flame.
5. If the flame is shut-down or blown out during operation, the ignitor will immediately go into "Trial For Ignition" again for 10 seconds.
6. **However; if during any 10 second "Trial For Ignition", the flame is not established, the ignition system goes into "Safety Lock-Out" and will not reactivate the "Trial For Ignition" until there is a current interruption for a period of 10 seconds. This interruption can be provided by opening the dryer loading door.**

### 3-25 IGNITION SYSTEM—CHECK OUT

1. If flame is present during "Trial For Ignition" period but the system shuts down, there is an improper ground. The entire ignition system is grounded together including the electrode assembly, the electrode mounting bracket, the burners and the burner bracket.
2. If there is no spark or intermittent spark, note spark gap and electrode location on Figure 3-9. **(THESE SPACINGS ARE IMPORTANT.)** Next, check for cracks in the ceramic insulator. Replace electrode assembly if necessary. Also check for carbon or foreign material on the electrodes. Clean if necessary, but be certain of gap and spacing when completed.
3. Check orange hi-voltage lead wire for damage or cracks in insulation. **(This lead wire must not be taped or connected to any metal edges along its length to prevent pinching and arcing. Also, do not bundle this wire with other wires.)**

### 3-26 SPARK ELECTRODE ASSEMBLY—REMOVAL

1. Disconnect wires to electrodes.
2. Remove one screw fastening the electrode mounting bracket to the burner support bracket. The entire assembly will slip out for ease of servicing.

### 3-27 GAS VALVE & MANIFOLD REMOVAL

1. Close off gas supply at main shut-off valve (See Figure 3-8). Remove two screws from manifold support bracket.
2. Loosen and remove gas connection between main shut-off valve and gas control valve. Disconnect wires to valve coils. This will allow removal of gas valve and manifold assembly.

### 3-28 MAIN BURNER ORIFICE REMOVAL

1. Remove manifold from gas valve assembly.
2. Using an open end wrench, remove orifices from manifold.

### 3-29 MAIN BURNER REMOVAL

1. Remove the screw securing each burner to the burner support bracket.
2. Remove the screw securing the electrode mounting bracket to the burner support bracket, and swing the entire electrode assembly to the side in order to clear the burners when lifted out.

### 3-30 PRESSURE REGULATOR ADJUSTMENT

Use the following procedure whenever it is necessary to check the pressure regulator setting.

**NOTE: Any adjustment of the pressure regulator must be made with a manometer attached at the plug in the main burner manifold.**

1. Shut off the gas supply to the dryer.
2. Remove the  $\frac{1}{8}$ " pipe plug from the main burner manifold.
3. Attach a manometer to the manifold part.
4. Remove the pressure regulator cover screw on the gas valve.
5. Open the shut-off valve, and operate the dryer.
6. Adjust the pressure for a manometer reading of 3.5" water column gas pressure. (11.0" on L.P.)

**NOTE: The main burners must be operating when adjusting the pressure regulator.**

7. Shut off the gas supply to the dryer. Remove the manometer and install the  $\frac{1}{8}$ " pipe plug in the manifold.
8. Open the shut off valve, and check for gas leaks.

### 3-31 MOTOR AND IMPELLER REMOVAL

1. Remove the drive guard from the back.
2. Remove the four screws holding the impeller cover plate to the back panel.

3. Remove the two set screws (90° apart) on the motor pulley and remove the pulley.
4. Remove the terminal cover plate from the motor and remove the wiring from the terminals and the conduit from the motor.
5. Remove the motor mounting nuts, washers and lockwasher securing the motor to the motor bracket.

### **3-32 DRIVE BELT REMOVAL**

1. Grasp and slide the drive belt off the intermediate pulley. (Refer figure 3-10).

### **3-33 DRIVEN BELT REMOVAL**

1. Grasp and slide the driven belt off the driven pulley as the driven pulley is rotated. (Refer figure 3-10).

**NOTE: Be sure the tension spring is in place when belts are replaced.**

### **3-34 CYLINDER PULLEY REMOVAL**

1. Remove nut holding pulley to cylinder shaft.

**NOTE: Do not lose locking key in cylinder shaft when removing pulley.**

### **3-35 INTERMEDIATE PULLEY AND TENSION ARM REMOVAL (Refer figure 3-10).**

1. The intermediate pulley can be removed by removing the snap rings holding the pulley to the tension arms.
2. With the pulley and tension spring removed, remove the snap ring from the center drive pin. The tension arms can now be removed in two pieces.

**NOTE: Be sure and note the position in which the tension arms are removed.**

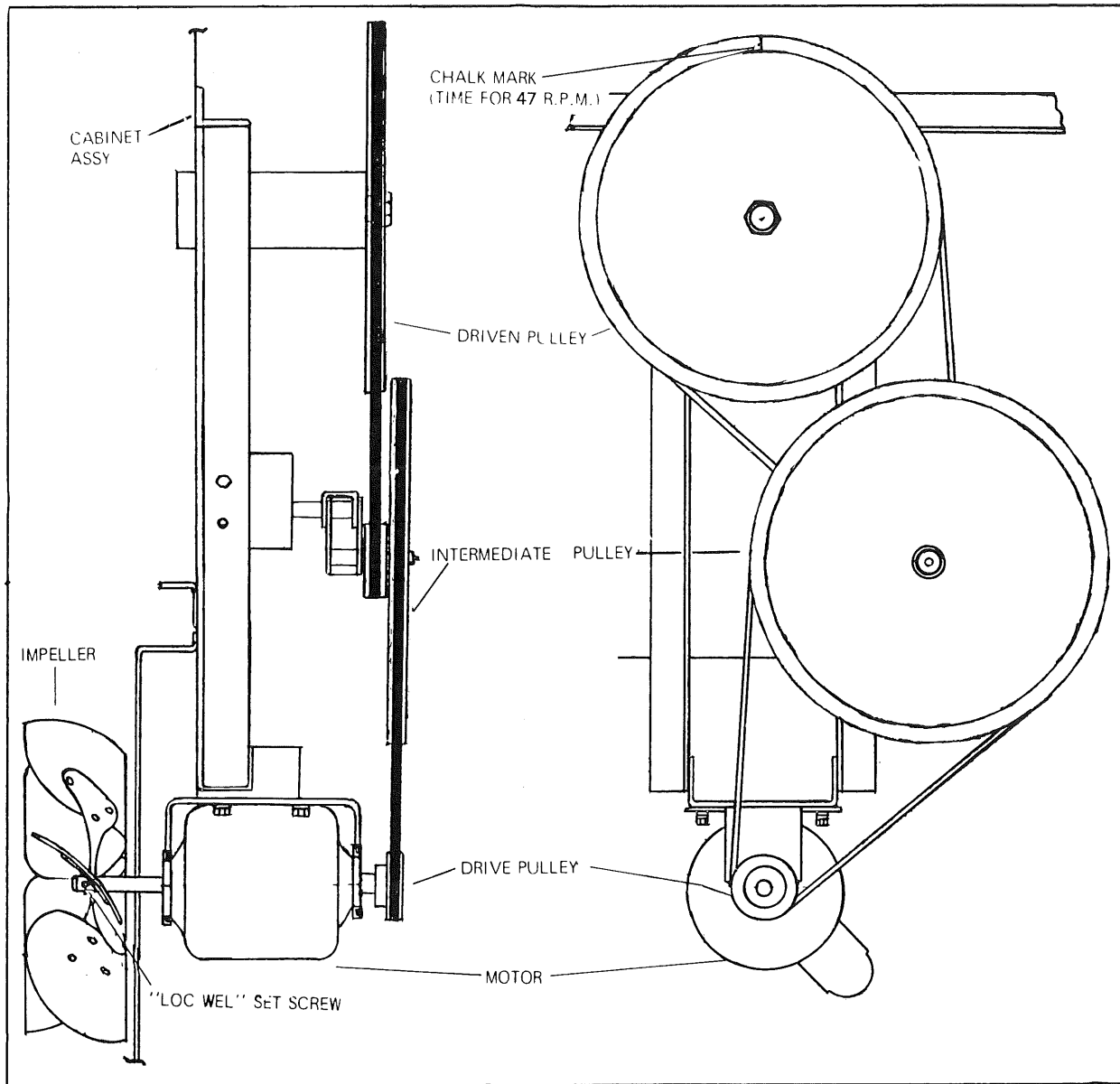

**Figure 3-10. Pulley and Belt Assembly**

### 3-36 CYLINDER REMOVAL

1. Remove front panel.
2. Remove driven belt, cylinder pulley, and key from cylinder shaft.
3. From the front of the machine, remove the cylinder and spider assembly. (Refer figure 3-11).

- To reassemble, the cylinder shaft must be guided into and through the tumbler bearing housing assembly. A dummy shaft will be required for insertion into the rear of this housing assembly. This will line up the bearing spacer with the bearings in the housing assembly. (Refer figure 3-12).

**NOTE:** Be sure the cylinder is pushed all the way to the rear. If there is any doubt use the cylinder pulley and nut as a puller to position cylinder properly.

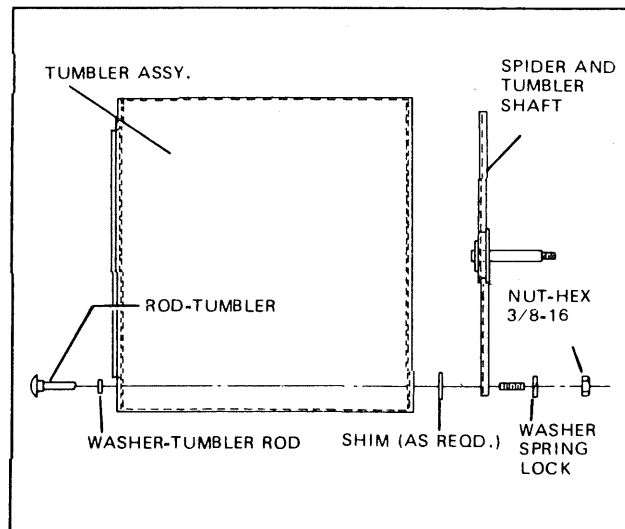

**Figure 3-11. Tumbler Assembly**

### 3-37 ADJUSTMENT OF CYLINDER WITH FRONT PANEL IN POSITION (Refer figure 3-12).

- Loosen the two top adjusting bolts and two bottom adjusting nuts and lock nuts holding the bearing housing to the drive plate.
- Loosen the four mounting bolts on the side channels and remove all shims. (Save for reuse if necessary).
- Open the clothes door and insert a  $\frac{1}{2}$ " thick shim at the 3 and 9 o'clock position between the front panel flange at the door opening and the opening in the cylinder. Insert a  $\frac{3}{4}$ " thick shim at the 12 o'clock position and a  $\frac{1}{4}$ " thick shim at the 6 o'clock position.
- Tighten the two bottom adjusting nuts and tighten locking nuts.
- Tighten the bottom right mounting bolt, then the top left mounting bolt. Tighten the remaining two bolts. (Shim where and if necessary).
- Tighten the two top adjusting bolts.
- Remove all the shims from between the front panel flange and cylinder (3,6,9, and 12 o'clock).
- Spin the cylinder to check for rubbing against baffles, pressing down hard while rotating. If rubbing is detected, repeat procedure paying particular attention to placement of shims between bearing housing and side channels.

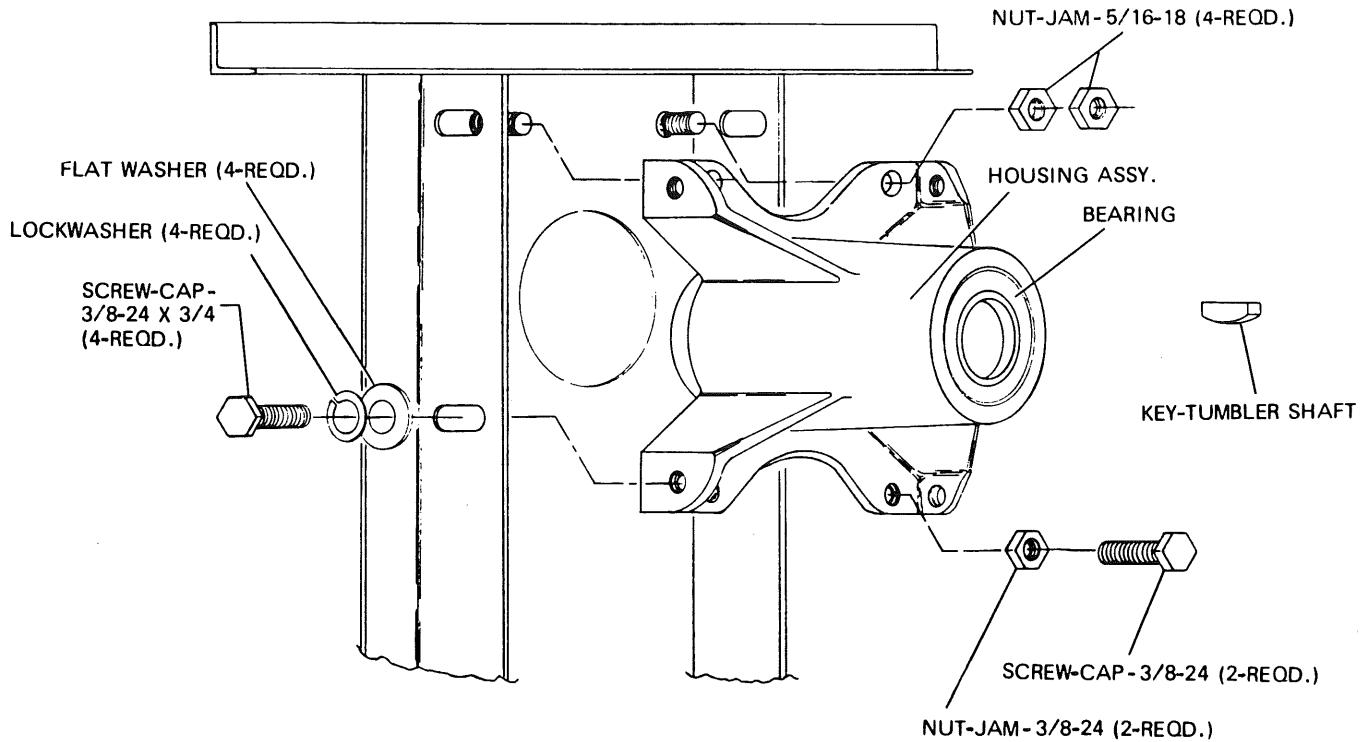

Figure 3-12. Tumbler Bearing Assembly

3-38 BEARING HOUSING BEARING REMOVAL (Refer figure 3-12)

1. With the cylinder removed, insert a punch through the rear bearing and spacer and drive the front bearing out of the bearing housing.
2. From the front of the machine drive out the rear bearing in like manner.

**NOTE:** To replace drum bearings, keep in mind the bearings must be flush with the bearing housing. Replacing the bearings may be accomplished by either of the following methods.

- A. Place the spacer in the bearing housing. Position the bearings, one at a time, and using a rubber mallet, drive each bearing in flush with the bearing housing.
- B. By using a  $\frac{7}{8}$ " bolt and nut 10" long and two  $\frac{7}{8}$ " washers. Place a washer over the bolt and place a bearing and the spacer over the bolt. Slip bolt and spacer through the bearing housing. Place the other bearing over the bolt. Locate both bearings squarely in the bearing housing. Place washer and nut on bolt. Tighten nut until both bearings are flush with the ends of the bearing housing.

# Section 4

## PREVENTIVE MAINTENANCE INSTRUCTIONS AND TROUBLE SHOOTING GUIDE

### 4-1 PREVENTIVE MAINTENANCE

#### DAILY

1. Clean lint screen. Use soft brush if necessary.
2. Check lint screen for tears or holes. Replace if necessary.
3. Clean lint from screen compartment.

#### MONTHLY

1. Remove lint accumulation from end bells of motor.
2. Remove lint from control compartment and coin acceptor mechanism.
3. Remove lint and dirt accumulation from top of the dryer and all areas above, below and around the burners and burner housing. Failure to keep this portion of the dryer clean can lead to a build-up of lint creating a fire hazard.
4. Place a few drops of light oil on clothes door hinge.
5. Grease bearings and shaft of intermediate drive pulley. Use Alemite gun and grease No. BRS-2 Molycote.
6. Remove lint and dirt from temperature sensor.

#### QUARTERLY

1. Check all belts for looseness, wear or fraying.
2. Inspect gasket of door glass for excessive wear.
3. Check tightness of all fasteners holding parts to support channel.
4. Check tightness of all set screws.
5. Inspect impeller for tightness of blades to hub.
6. Check tightness of cylinder shaft retaining nut.
7. Remove back inspection plate and check tumbler thru-bolts for tightness.
8. Remove lint accumulation from primary air ports in burners.
9. Grease pivot pins and tension arms where in contact with each other.

**SEMI-ANNUALLY**

1. Remove and clean main burners.
2. Remove all orifices and examine for dirt and hole obstruction.
3. Remove all lint accumulation. Remove front panel, lint screen housing and remove lint accumulation.

**ANNUALLY**

1. Check intermediate pulley bearings for wear.
2. Check and remove any lint accumulation from exhaust system.

**4-2 TROUBLE SHOOTING GUIDE**

**P R O B L E M**

**P R O B A B L E C A U S E**

**R E M E D Y**

MOTOR (TUMBLER) DOES NOT TURN



- |   |  |
|---|--|
| <ol style="list-style-type: none"> <li>1. Loading door not closed — Door switch not made.</li> <li>2. Electronic Control not energized. — Is a "Temp." indicator light on.</li> <li>3. Push-Start Switch Operation</li> <li>4. Wire connections between coin acceptor, electronic control, and motor.</li> <li>5. Motor thermal protection is tripped out—overheated</li> <li>6. Motor inoperative</li> <li>7. Push — Start Switch inoperative</li> <li>8. Electronic control inoperative</li> <li>9. Broken Drive Belt</li> <li>10. Coin Switch inoperative</li> </ol> | <p>Close door completely.</p> <p>Activate control.</p> <p>Hold switch in until motor is at full speed.</p> <p>Check Wire Connections.</p> <p>Vacuum lint out of front end of motor.</p> <p>Check capacitor and motor.</p> <p>Check and Replace Membrane switch Ass'y.</p> <p>Check and Replace.</p> <p>Check and Replace.</p> <p>Replace coin switch</p> |
|---|--|

MOTOR (TUMBLER) TURNS, BUT NO SPARK AT BURNER



- |  |   |
|--|---|
| <ol style="list-style-type: none"> <li>1. Fuse Blown 1.5A (located near transformer.)</li> <li>2. Temperature Sensor</li> <li>3. Transformer inoperative</li> <li>4. Blower damper not operating (damper plate or switch)</li> <li>5. Ignition Module inoperative</li> <li>6. Spark Gap at Electrode Assy.</li> <li>7. Improper ground (yellow grounding wires)</li> <li>8. Spark System locked out</li> <li>9. Hi-Limit Therm. inoperative</li> <li>10. Electronic Control Inoperative</li> </ol> | <p>Check for cause — replace.</p> <p>Check and Replace</p> <p>Should have 24V. at secondary side.</p> <p>Adjust plate or switch operation — See Fig. 3-5</p> <p>Check and Replace.</p> <p>Gap spec. 1/8" + .030</p> <p>Clean and Replace wire and connections as needed.</p> <p>Open loading door to break circuit—wait 30 sec.—try again.</p> <p>Check and Replace.</p> <p>Check and Replace</p> |
|--|---|

**P R O B L E M**

**P R O B A B L E C A U S E**

**R E M E D Y**

MOTOR (TUMBLER) TURNS AND SPARK IS OK, BURNERS DO NOT LIGHT



SLOW DRYING OR LOW TEMPERATURE IN DRYER



- 1. Gas not on
- 2. Spark Electrode not centered over burner
- 3. Spark Electrode too far from burner (too high or low).
- 4. Improper gas pressure at manifold
- 5. Inoperative coil on gas valve
- 6. Bad wire connections from Ignition Module to valve

- Check shut-off valve. Also check shut-off on main gas valve.
- Center electrode ends over center of burner.
- Check— $\frac{3}{8}$ " from burner to electrodes.
- Check pressure at plug in manifold — (see Fig. 5-11).
- Check gas valve operator coils — replace.
- Check and Repair.

- 1. Incorrect temperature setting
- 2. Air restrictions —
  - A.) Lint screen clogged
  - B.) Improper exhaust system or clogged exhaust pipes
  - C.) Damper plate in Tee Assy. not opening
  - D.) Inadequate make-up air supply
- 3. Temp. Sensor Dirty
- 4. Defective Hi-Limit Thermostat

- Check Programmed value
- Clean Lint screen.
- See installation instructions for exh. size — clean.
- Clear damper plate movement
- Each dryer requires 1 sq. ft. make-up air.
- Clean Sensor Tube
- Check and Replace.

# Section 5

## PARTS DATA

### KITS, ASSEMBLIES, & COMMON PARTS

<b>Part Number</b>	<b>Description</b>	<b>D D H 3 E Q</b>	<b>D D H 3 E D Q</b>
9732-103-009	Dark Blue Type 2 Controller . . . . .	1	1
9857-116-003	Ignition Control . . . . .	1	1
9875-002-001	Electrode Ignition Assembly . . . . .	1	1
9576-203-002	Hi-Limit Thermostat . . . . .	1	1
8636-018-001	Fuse . . . . .	1	1
9054-045-001	Fuseholder . . . . .	1	1
8711-002-001	Transformer . . . . .	1	1
9822-026-001	Lint Screen Assembly . . . . .	1	1
9539-432-001	Damper Switch . . . . .	1	1
9040-077-002	Narrow Belt . . . . .	1	1
9040-073-004	Wide Belt . . . . .	1	1
9861-015-001	Tension Arm Assembly . . . . .	1	1
9568-012-001	Spider . . . . .	1	1
9244-079-001	Loading Door Handle . . . . .	1	1
9539-461-001	Door Switch . . . . .	1	1
9501-003-001	Temp Sensor Assembly . . . . .	1	1

# Section 5

## PARTS DATA

### CABINET GROUP (Figure 5-1)

Key	Part Number	Description	D D H 3 E Q	D D H 3 E D Q
A1	9454-569-005	Panel, Front - White	1	1
A1	9454-569-006	Panel, Front - B Or.	1	1
A1	9454-569-007	Panel, Front - H.G.	1	1
A1	9454-569-008	Panel, Front - ALM.	1	1
A1	9454-569-009	Panel, Front - SAND	1	1
A2	9454-008-010	Screw, #10 -Black	6	6
*	8640-399-001	Nut, Spring (Front Panel to Side)	4	4
A2	8641-436-000	Washer, Fiber (Under Screw HD.)	6	6
*	9545-008-006	Screw, #10 (Lower Front Flange)	3	3
*	9086-015-001	Catch - Loading Door (Plastic)	1	1
A3	9960-256-011	Door Ass'y., Loading - Brown (incl. items A3 thru A6)	1	1
A3	9960-255-003	Door Ass'y., Loading - Brown	1	1
A4	9212-002-004	Glass, Loading Door	1	1
A5	9206-413-001	Gasket, Door Glass	1	1
*	9548-117-000	Support, Door Glass	1	1
A6	9206-394-002	Gasket, Outer Door	1	1
A7	9244-079-001	Handle, Door	1	1
*	9545-019-002	Screws, Handle MTG.	2	2
*	9531-033-001	Stud, Door Catch	1	1
*	8640-413-001	Nut, Door Catch Stud	1	1
A8	9982-280-002	Plate Ass'y., Hinge - White	1	1
A8	9982-280-003	Plate Ass'y., Hinge - B. Or.	1	1
A8	9982-280-004	Plate Ass'y., Hinge - H.G.	1	1
A8	9982-280-005	Plate Ass'y., Hinge - ALM.	1	1
A8	9982-280-006	Plate Ass'y., Hinge - Sand	1	1
*	9545-012-015	Screw, #10 - Hinge Plate to Door	4	4
*	8640-413-002	Nut, #10 - Hinge Plate to Door	4	4
A9	9544-047-002	Strap, Hinge - White	1	1
A9	9544-047-003	Strap, Hinge B. Or.	1	1
A9	9544-047-004	Strap, Hinge H.G.	1	1
A9	9544-047-005	Strap, Hinge AL.	1	1
A9	9544-047-006	Strap, Hinge Sand	1	1
*	9545-008-009	Screw, #10 Hinge strap to Front Panel	4	4
A10	9545-052-001	Screw, Special - Loading Door to Hinge	1	1
A11	9960-243-013	Door Ass'y., Lower Service - White	1	1
A11	9960-243-014	Door Ass'y., Lower Service - B. Or.	1	1
A11	9960-243-015	Door Ass'y., Lower Service - H.G.	1	1
A11	9960-243-016	Door Ass'y., Lower Service - ALM.	1	1
A11	9960-243-017	Door Ass'y., Lower Service - Sand	1	1
A12	9578-074-003	Trim, Lower Door Top	1	1
*	9545-008-010	Screw, #10 - Trim MTG.	4	4
A13	8650-006-003	Lock - Serv. Door	1	1
A14	9578-076-002	Trim - Kick	1	1
A15	9545-008-010	Screw, #10 - Trim MTG.	3	3
*	8520-223-003	Nut, Spring - Trim MTG.	3	3
A16	8650-016-002	Lock, Upper Door	1	1
A16	6292-006-006	Key (For 8650-016-002)	1	1
A17	9108-091-002	Door - Upper Service - White	1	1
A17	9108-091-003	Door - Upper Service - B. Or.	1	1
A17	9108-091-004	Door - Upper Service - H.G.	1	1
A17	9108-091-005	Door - Upper Service - ALM.	1	1
A17	9108-091-006	Door - Upper Service - Sand	1	1
A18	9412-069-001	Nameplate - "Dexter"	1	1
*	8520-141-000	Nut - Spring	2	2
A19	8502-606-001	Label, Instruction (Service Door Front)	1	1
A20	8638-211-001	Rivet, Drive - Upper Door MTG.	2	2
A20	8641-581-005	Washer (Under Rivet HD.)	2	2
*	9548-268-001	Support, Upper Door	1	1
A21	8544-005-000	Leg, Leveling	4	4

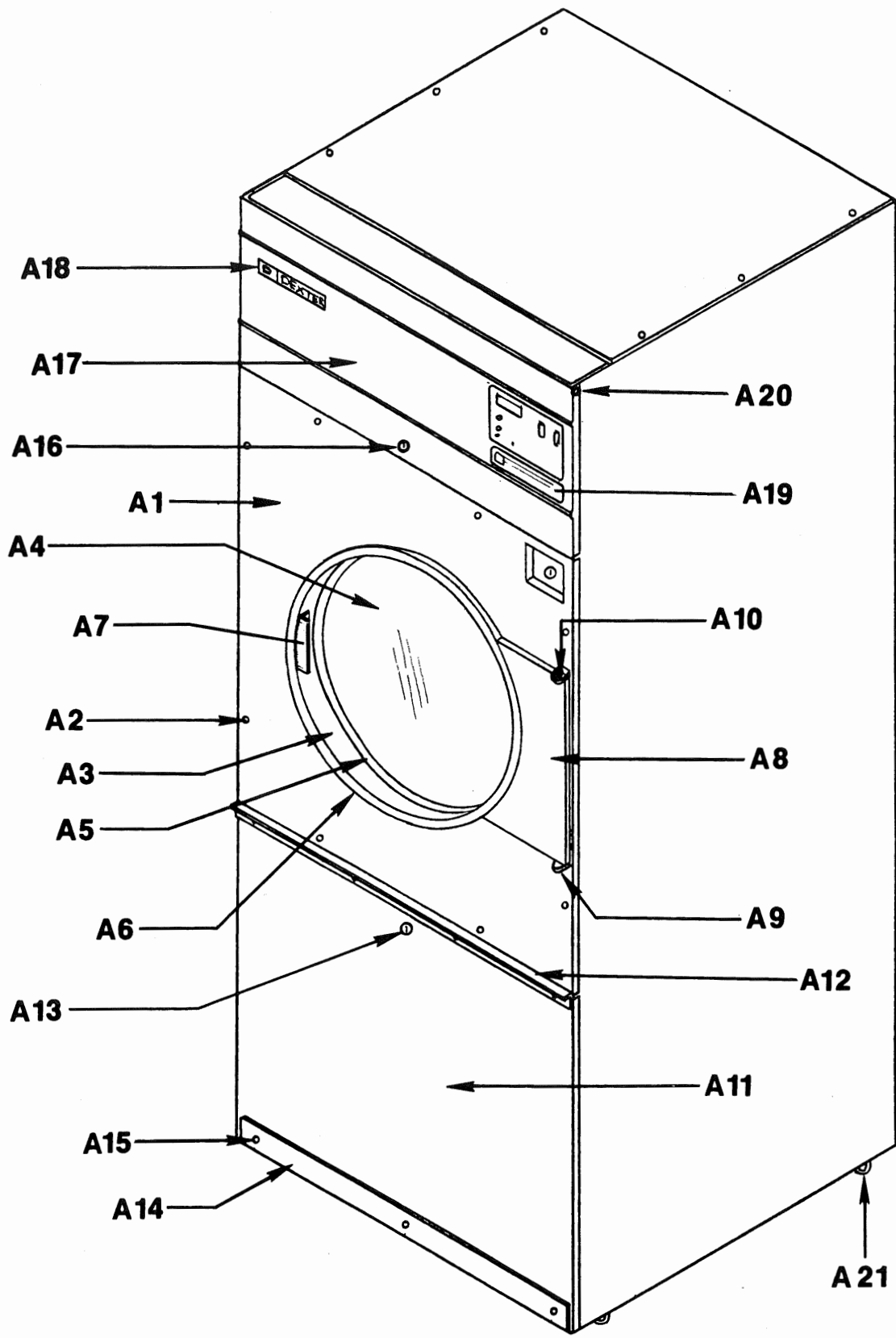
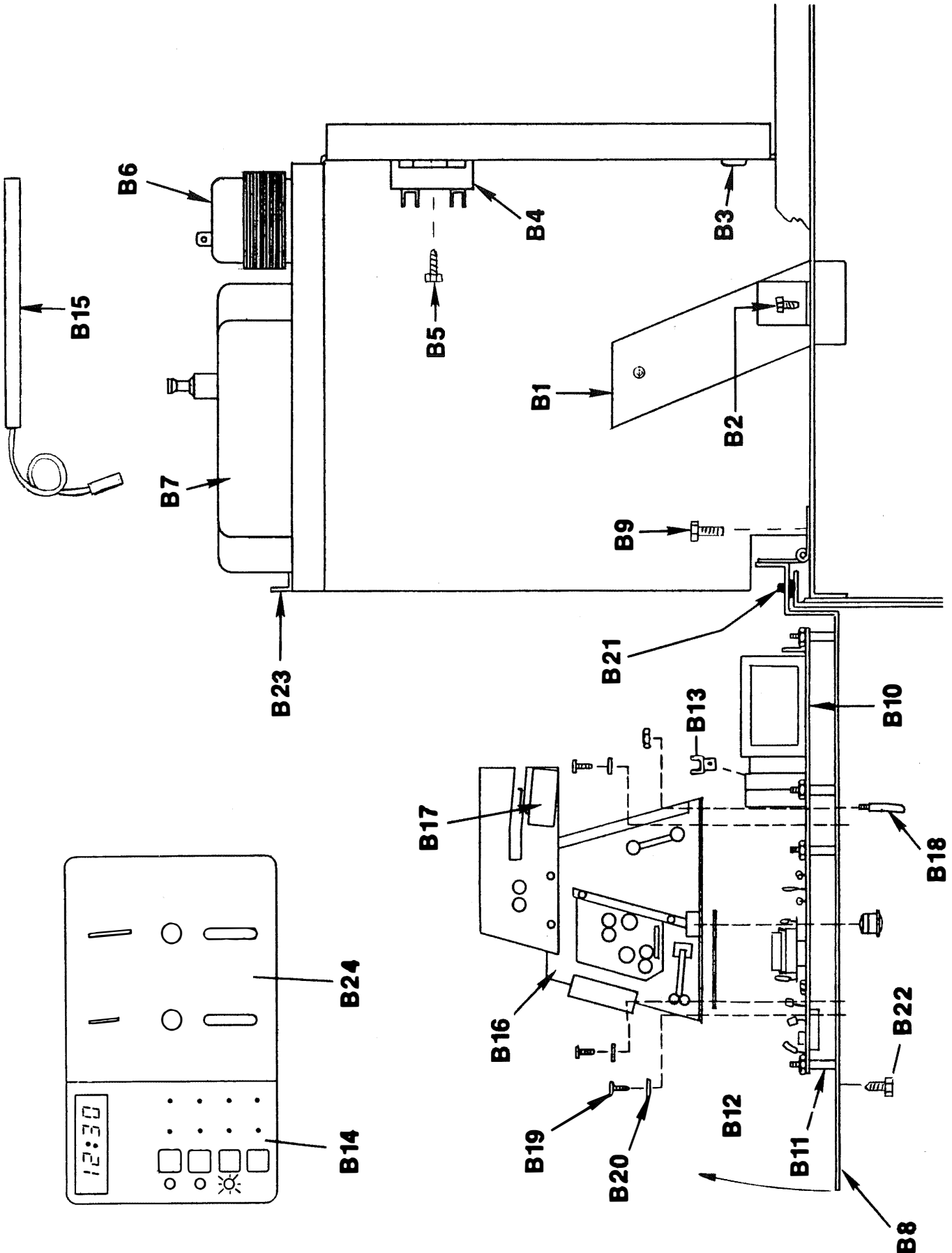

Fig. 5-1



CONTROL HOUSING GROUP (Fig. 5-2)

**CONTROL HOUSING GROUP (Figure 5-2)**

<b>Key</b>	<b>Part Number</b>	<b>Description</b>	<b>D D H 3 E Q</b>	<b>D D H 3 E D Q</b>
B1	9940-013-001	Chute Ass'y., Coin . . . . .	1	2
B2	9545-008-006	Screw #10 . . . . .	1	2
B3	9209-037-002	Grommet, Temp. Cable . . . . .	1	1
B4	9897-026-001	Block, Terminal . . . . .	1	1
B5	9545-031-004	Screw #6 . . . . .	2	2
*	9053-067-001	Brushing - Wire (Door Switch Wires) . . . . .	1	1
B6	8711-002-001	Transformer		
B6	8640-397-001	Nut		
B7	9857-116-001	Control Ass'y, Ignition		
B8	9982-281-002	Plate Ass'y., - Electronic Control . . . . .	1	1
B9	9545-008-006	Screw . . . . .	2	2
B10	9471-002-001	Electronic Control (Printed Circuit Ass'y.) . . . . .	1	1
B11	9538-157-001	Spacers - Circuit Board . . . . .	6	6
B12	8640-411-001	Nuts - Circuitboard . . . . .	6	6
B12	8641-582-005	Lockwasher #6 . . . . .	1	1
B13	8653-074-001	Terminal, Chair - on Relay		
*	9627-651-001	Harness, Wiring (Electronic Control) . . . . .	1	1
*	9627-652-001	Harness, Wiring (Dual Coin) . . . . .		1
B14	9801-058-001	Switch Ass'y. - Membrane . . . . .	1	1
B15	9501-003-001	Sensor Ass'y. - Temperature . . . . .	1	1
*	9083-112-001	Clip - Temperature Sensor . . . . .	1	1
*	9209-037-001	Grommet - Temperature Sensor . . . . .	1	1
B16	9021-002-003	Acceptor - Coin 25¢, Complete . . . . .	1	1
B16	9021-002-004	Acceptor - Coin 10¢, Complete (Includes the following parts) . . . . .		1
B17	9539-466-001	Switch, Coin . . . . .	1	2
B18	9063-004-001	Bail, Coin Return . . . . .	1	2
B19	9545-025-021	Screw M3 - Acceptor MTG . . . . .	2	4
B20	8641-573-012	Lockwasher M3 - Acceptor MTG . . . . .	2	4
B21	9051-021-001	Bumper . . . . .	2	2
B22	9545-045-002	Screw, Top MTG . . . . .	1	1
B23	9039-981-001	Bracket, Control Plate MTG . . . . .	1	1
B24	8502-608-002	Label - Control Plate (25¢ only) . . . . .	1	
B24	8502-608-001	Label - Control Plate (10¢/25¢) . . . . .		1

### ELECTRICAL COMPONENTS (Figure 5-3)

Key	Part Number	Description	D D H 3 E Q	D D H 3 E D Q
C1	9376-259-006	Motor, Drive 115V. - 60 Hz. ....	1	1
C2	9539-432-001	Switch, Damper (See Fig. 5-5) ....	1	1
C3	8658-012-000	Box - Elec. Junction ....	1	1
*	8643-005-000	Cover, Junction Box ....	1	1
*	9545-008-006	Screw, Box Mtg. ....	2	2
C4	9897-026-001	Block, Terminal ....	1	1
*	9545-031-004	Screw, Block Mtg. ....	2	2
C5	9471-002-001	Electronic Control (See Fig. 5-2) ....	1	1
C6		Coin Acceptor (See Fig. 5-2) ....		
C7	8711-002-001	Transformer (24V.) ....	1	1
C8		Fuse & Fuse Holder (See Fig. 5-11) ....		
C9	9857-115-001	Gas Control Assy., (NAT.) (See Fig. 5-11) ....	1	1
C9	9857-115-002	Gas Control Assy., (L.P.) (See Fig. 5-11) ....	1	1
C10	9857-116-001	Control, Ignition (See Fig. 5-11) ....	1	1
C11	9576-203-002	Thermostat, Hi-Limit (See Fig. 5-11) ....	1	1
C12	9539-461-001	Switch, Door (See Fig. 5-4) ....	1	1
C13	9501-003-001	Sensor Ass'y — Temperature		

\* NOT ILLUSTRATED

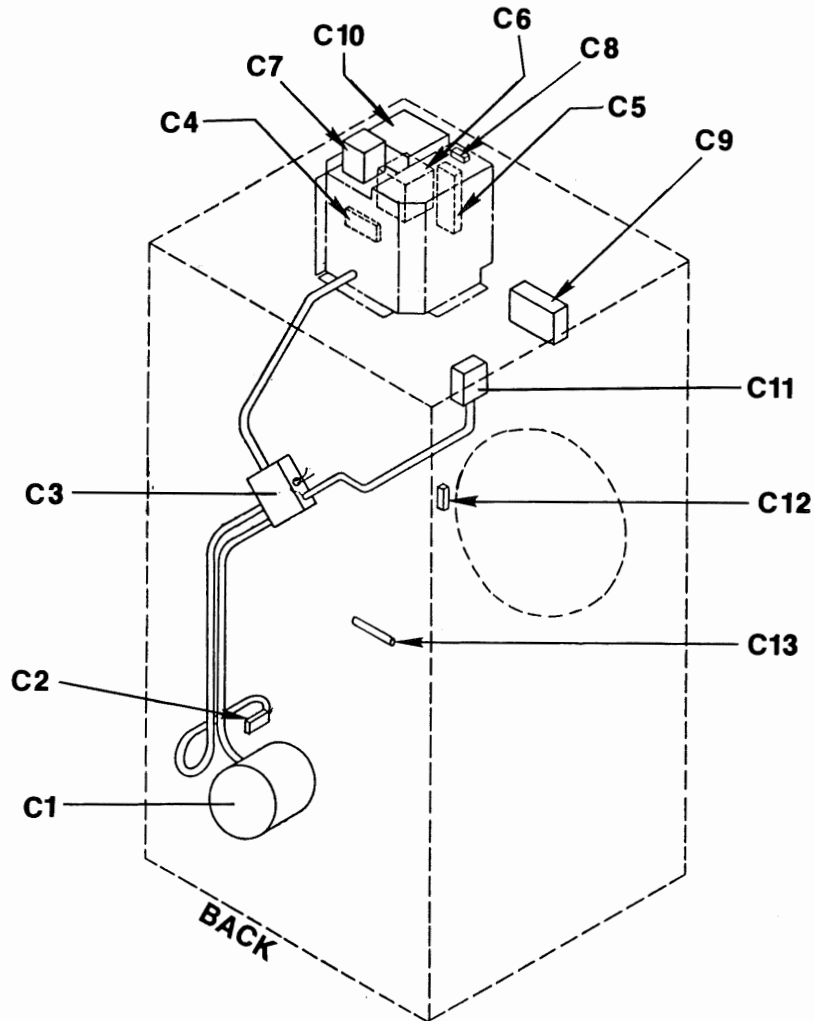

**ELECTRICAL COMPONENTS Fig. 5-3**

**DOOR SWITCH GROUP (Figure 5-4)**

Key	Part Number	Description	D D H 3 E Q	D D H 3 E D Q
D1	9041-076-001	Box, Door Switch .....	1	1
D2	9550-159-001	Shield, Switch Insulator .....	1	1
D3	9539-461-001	Switch, Door .....	1	1
D4	8640-401-001	Nut, Twin .....	1	1
D5	9074-255-001	Cover, Switch Box .....	1	1
D6	9545-008-001	Screw, (Switch Assy., to Front Panel) .....	2	2
D7	9008-004-001	Actuator, Switch .....	1	1
D8	9545-020-001	Screw, Switch to Box .....	2	2
D9	6068-041-001	Conduit, Special .....	1	1
D10	9545-012-016	Screw, Conduit to Front Panel .....	1	1
D11	8640-355-001	Nut, Elastic Stop .....	1	1

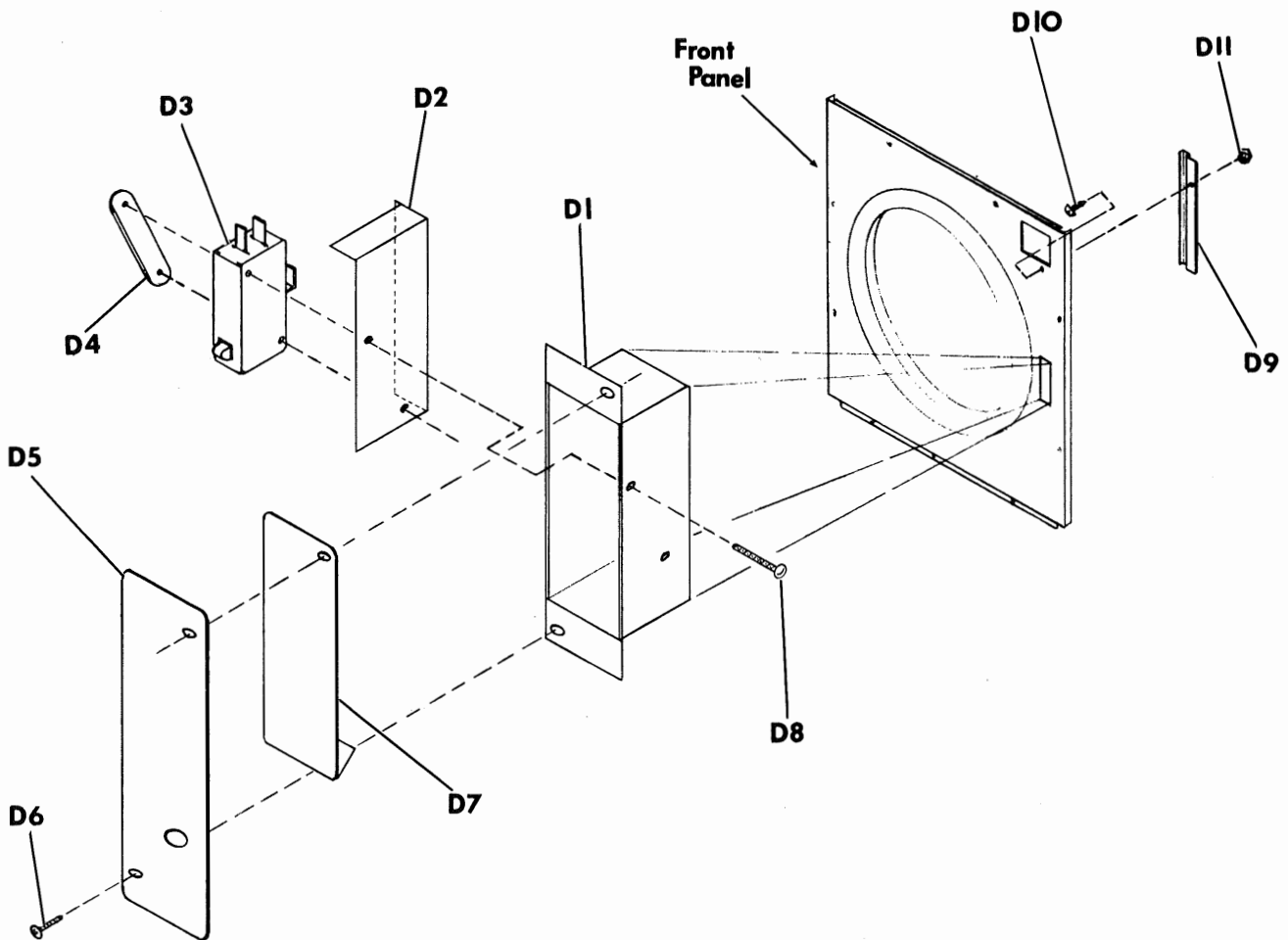

**DOOR SWITCH GROUP**  
**Fig. 5-4**

**DAMPER & DAMPER SWITCH ASSEMBLY (Figure 5-5)**

			<b>D D H 3 E Q</b>	<b>D D H 3 E D Q</b>
<b>Key</b>	<b>Part Number</b>	<b>Description</b>		
E1	9539-432-001	Switch, Damper . . . . .	1	1
E2	9545-044-002	Screw, Damper Sw. Mtg. and Adj. . . . .	3	3
E3	8640-411-001	Nut, Damper Sw. Locking . . . . .	2	2
E4	8640-420-001	Nut, Damper Sw. Mtg. (Tandem Speed Nut) . . . . .	1	1
E5	9125-001-001	Damper . . . . .	1	1
E6	9451-146-001	Pin, Damper Hinge . . . . .	1	1
*	9074-242-001	Cover, Damper Sw. . . . .	1	1

**LINT HOOD & SCREEN ASSEMBLY (Figure 5-6)**

F1	9822-027-002	Hood Assy., Lint . . . . .	1	1
*	9822-026-001	Screen Assy., Lint . . . . .	1	1
F2	8640-300-011	Nut, Lint Hood Mtg. . . . .	6	6

**TUMBLER ASSEMBLY GROUP (Figure 5-7)**

G1	9848-101-001	Tumbler Assy. . . . .	1	1
G2	9568-009-002	Spider and Shaft Assy. . . . .	1	1
G3	9497-019-001	Rod, Tumbler . . . . .	3	3
G4	8640-415-001	Nut, Tumbler Rod . . . . .	3	3
G5	9552-013-000	Shim, Tumbler . . . . . (As Required)		
G6	8641-582-003	Lockwasher . . . . .	3	3
G7	8641-554-1	Washer, Flat . . . . .	3	3

**\* NOT ILLUSTRATED**

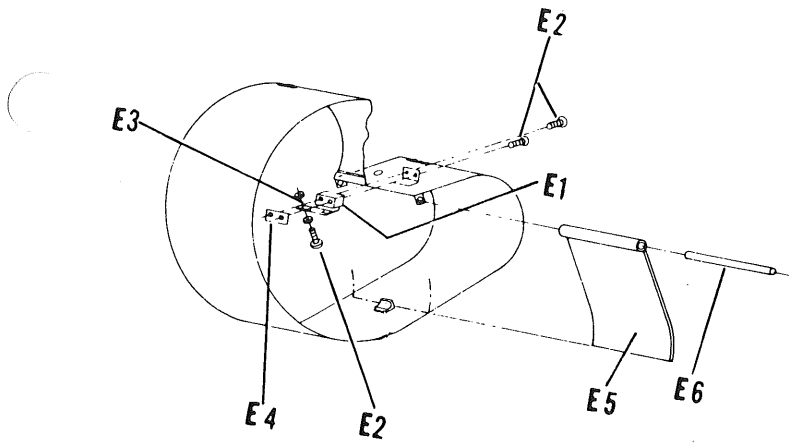

**Fig. 5-5. Damper and Damper Switch Group**

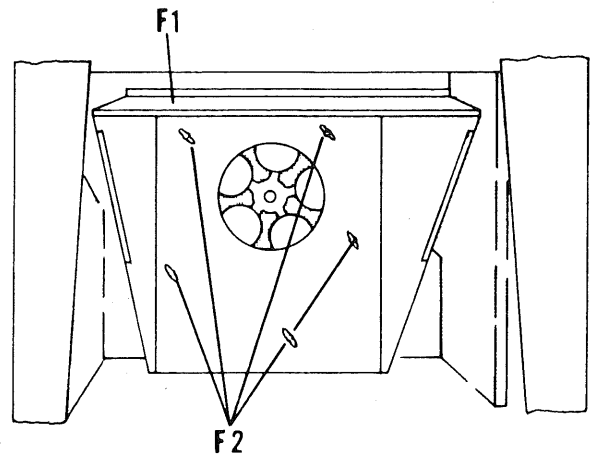

**Fig. 5-6. Lint Hood and Screen Group**

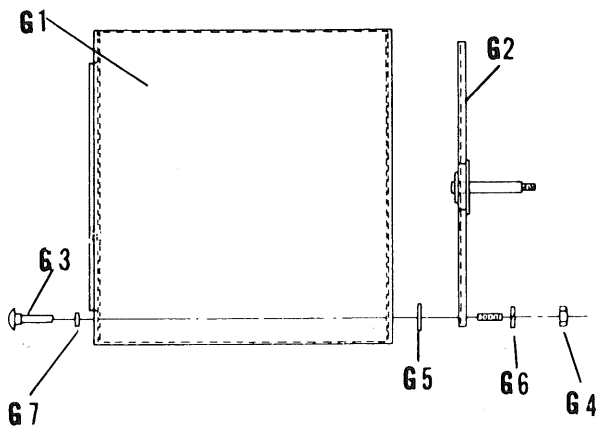

**Fig. 5-7. Tumbler Assembly Group**

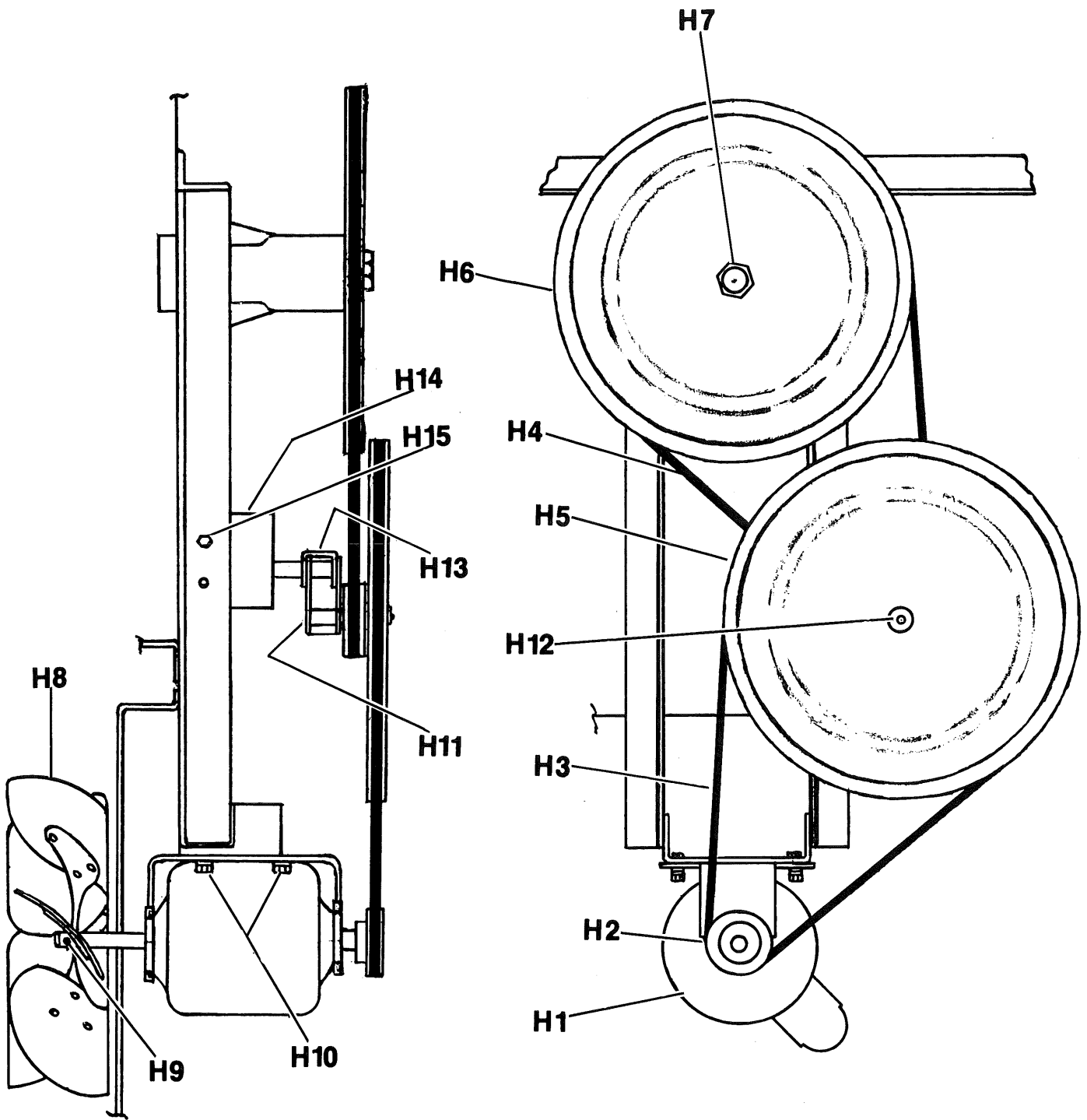

Fig. 5-8. Pulley, Belt and Motor Group

**PULLEY, BELT & MOTOR GROUP (Figure 5-8)**

<b>Key</b>	<b>Part Number</b>	<b>Description</b>	<b>D D H 3 E Q</b>	<b>D D H 3 E D Q</b>
H1	9376-259-006	Motor - 115V. 60 Hz. ....	1	1
H2	9453-157-001	Pulley - 60 Hz. ....	1	1
H3	9040-073-003	Belt (narrow) ....	1	1
H4	9040-073-004	Belt (wide) ....	1	1
H5	9908-039-001	Pulley Assy., Intermed. ....	1	1
*	9036-145-002	Bearing (included in item H5) ....	2	2
H6	9908-040-001	Pulley Assy., Tumbler ....	1	1
H7	8640-222-000	Nut, Tumbler Shaft ....	1	1
H8	9278-037-001	Impeller, Blower ....	1	1
H10	9545-014-004	Bolt, Motor Mtg. (5/16-18x5/8) ....	4	4
H10	8640-400-003	Nut, Hex ....	4	4
H11	9861-015-001	Arm, Tension (Short) ....	1	1
H12	9182-015-001	Fitting, Grease (included in item H11) ....	1	1
H13	9861-016-001	Arm, Tension ....	1	1
*	9487-200-003	Ring, Retaining ....	4	4
*	9451-141-001	Pin, Pivot ....	1	1
H14	9985-151-001	Bracket Assy., - Pivot ....	1	1
H15	9545-014-005	Bolt, Pivot Brkt. ....	3	3
H15	8640-400-002	Nut, Pivot Brkt. ....	3	3
*	9074-180-001	Cover, Impeller ....	1	1
*	9545-008-001	Screw, Impeller Cover ....	4	4
*	9452-253-000	Inspection Plate ....	1	1
*	9545-008-006	Screw, Insp. Plate ....	2	2

\* NOT ILLUSTRATED

### BEARING HOUSING ASSEMBLY (Figure 5-9)

Key	Part Number	Description	D D H 3 E Q	D D H 3 E D Q
J1	9803-160-002	Housing Assy., - Bearing Complete .....	1	1
J2	9036-130-001	Bearing, Ball .....	2	2
*	9538-139-001	Spacer, Brg. ....	1	1
J3	8641-581-009	Washer .....	4	4
J4	8641-582-003	Lockwasher .....	4	4
J5	9545-049-001	Bolt - (3/8-24x1) .....	6	6
J6	8640-415-002	Nut - (3/8-24) .....	2	2
J7	8640-400-002	Nut - (5/16-18) .....	4	4
J8	9306-006-000	Key, Tumbler shaft .....	1	1
*	8640-222-000	Nut, Tumbler .....	1	1

\* NOT ILLUSTRATED

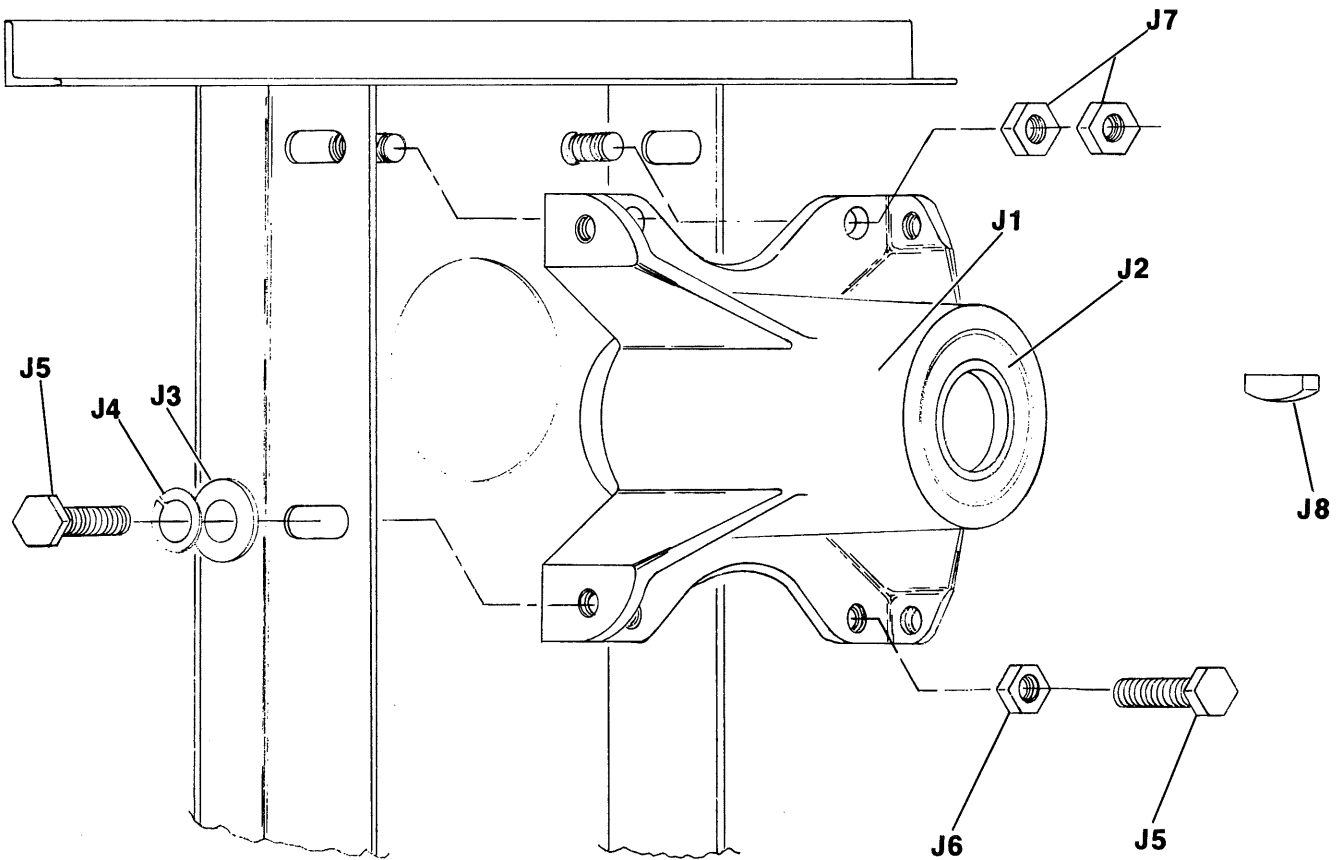

### BEARING HOUSING GROUP Fig. 5-9

**COIN BOX GROUP (Figure 5-10)**

<b>Key</b>	<b>Part Number</b>	<b>Description</b>	<b>D D H 3 E Q</b>	<b>D D H 3 E D Q</b>
K1	9807-077-002	Box Ass'y., Coin - White .....	1	1
K1	9807-077-003	Box Ass'y., Coin - B. Or. ....	1	1
K1	9807-077-004	Box Ass'y., Coin - H.G. ....	1	1
K1	9807-077-005	Box Ass'y., Coin - ALM. ....	1	1
K1	9807-077-006	Box Ass'y., Coin - Sand .....	1	1
K2	8650-012-002	Lock, Coin Box (Includes Key & Nut) .....	1	1
K3	9349-033-001	Latch - Coin Box .....	1	1
K4	8641-581-010	Washer, Coin Box Latch Spacer .....	A.R.	A.R.
K5	8640-400-002	Nut Hex, 5/16 - 18 (Latch MTG.) .....	2	2

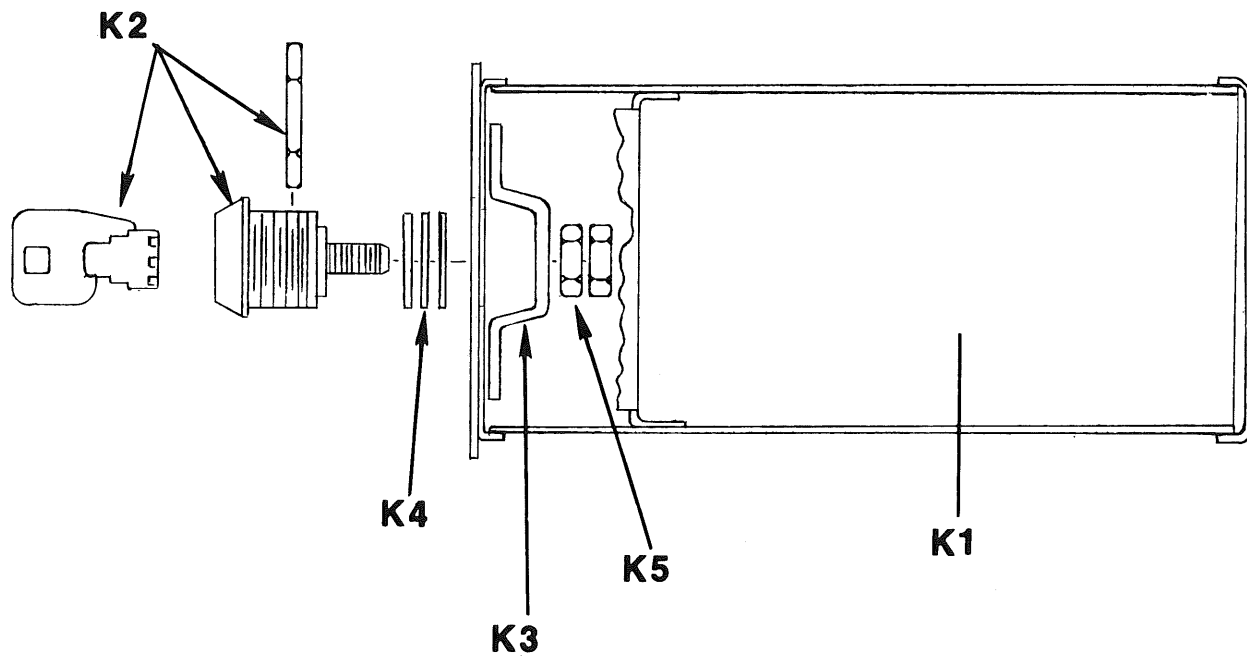

**COIN BOX GROUP  
Fig. 5-10**

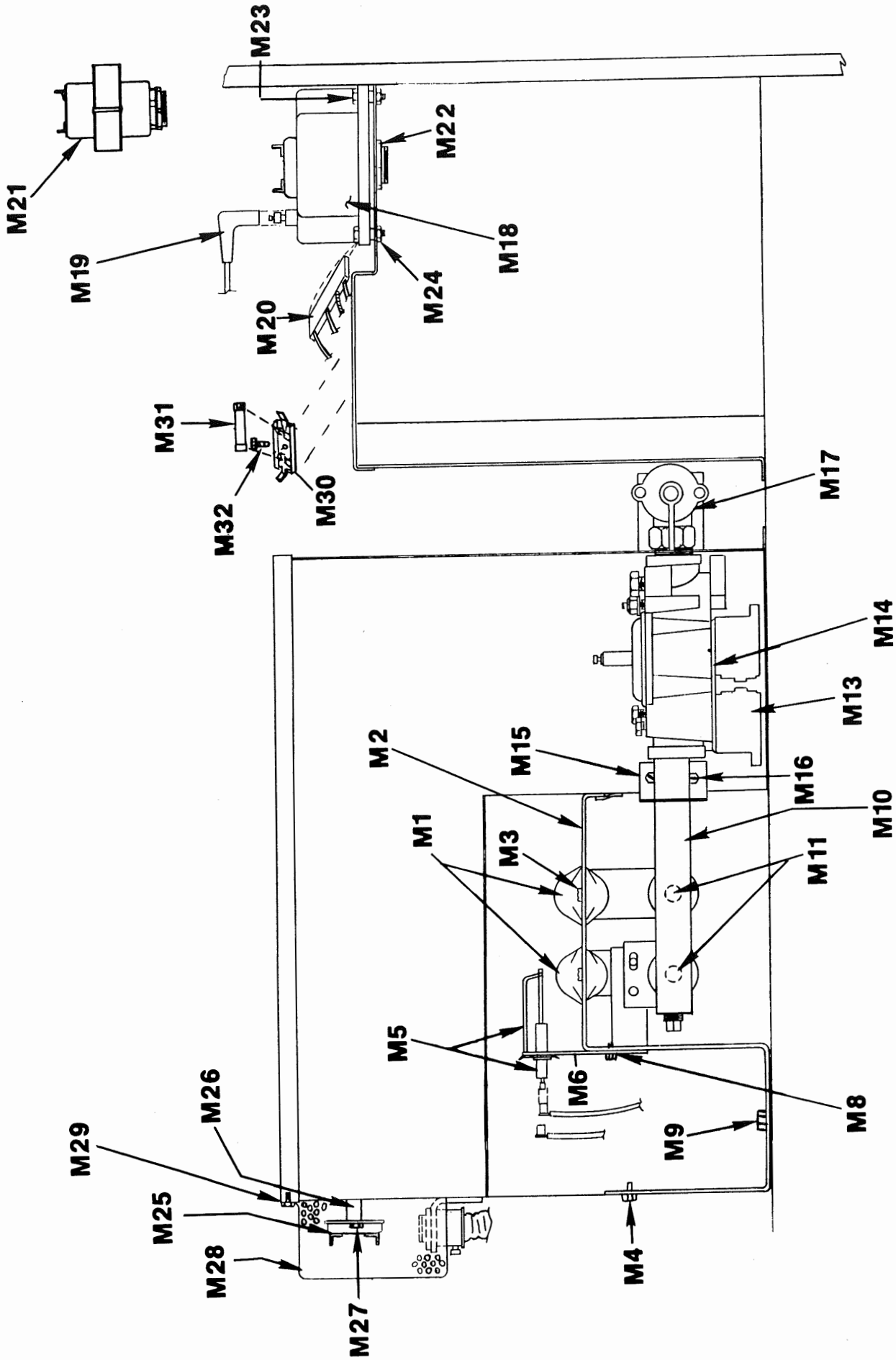

BURNER HOUSING ASSEMBLY & GAS CONTROL (Fig. 5-11)

**BURNER HOUSING ASSEMBLY & GAS CONTROL (Figure 5-11)**

<b>Key</b>	<b>Part Number</b>	<b>Description</b>	<b>D D H 3 E Q</b>	<b>D D H 3 E D Q</b>
M1	9048-018-001	Burner, Main .....	2	2
M2	9548-256-001	Support Brkt. - Burner .....	1	1
M3	9545-008-008	Screw, Burner to Support .....	2	2
M4	9545-008-008	Screw, Support Brkt. to Hsg. ....	1	1
M5	9875-002-001	Electrode Assy., - Ignition .....	1	1
M6	9985-161-001	Bracket Ass'y. - Electrode Mtg. ....	1	1
*	9545-045-001	Screw, Electrode to Brkt. ....	2	2
M8	9545-008-008	Screw, Brkt. to Support .....	1	1
M9	9545-008-006	Screw, Support Brkt. to Deck .....	1	1
M10	9381-009-002	Manifold, Main Burner .....	1	1
M11	9425-069-002	Orifice Nat. - #30 .....	2	2
M11	9425-069-003	Orifice L.P. - #48 .....	2	2
M12	9857-115-001	Control Assy., Gas Valve .....	1	1
M13	9089-037-001	Coil, Operator .....	2	2
M14	9486-127-001	Retainer, Coil .....	2	2
M15	9039-915-001	Bracket, Control Mtg. ....	1	1
M16	9545-008-003	Screw, Brkt. ....	2	2
M17	9379-164-001	Valve, Gas Shut-Off .....	1	1
M18	9857-116-001	Control, Ignition - Electronic .....	1	1
M19	9631-397-002	Wire, Hi-Voltage .....	1	1
M20	9627-650-001	Wire Harness, Ign. Cont. ....	1	1
M21	8711-002-001	Transformer, 24V. Sec. ....	1	1
M22	8640-397-001	Nut, Conduit - Transformer .....	1	1
M23	9545-044-002	Screw, Ign. Cont. Mtg. ....	2	2
M24	8640-163-000	Nut, Ign. Cont. Mtg. ....	4	4
M25	9576-203-002	Thermostat, Hi-Limit .....	1	1
M26	9538-142-001	Spacer, Mtg. ....	2	2
M27	9545-045-007	Screw, Mtg. ....	2	2
M28	9074-234-001	Cover, Hi-Limit .....	1	1
M29	9545-008-006	Screw, Cover Mtg. ....	1	1
M30	9054-045-001	Holder, Fuse .....	1	1
M31	8636-018-001	Fuse .....	1	1
M32	9545-031-005	Screw, Holder Mtg. ....	1	1
*	9732-045-001	Conversion Kit (from Nat. to L.P. Gas) .....	1	1

\* NOT ILLUSTRATED

**BACK GUARD & HEAT RECIRCULATING SYSTEM (Figure 5-12)**

Key	Part Number	Description	D D H 3 E Q	D D H 3 E D Q
N1	9208-039-001	Guard, Drive .....	1	1
N2	9454-595-002	Panel, Side Guard L.H. ....	1	1
N3	9454-596-002	Panel, Side Guard R.H. ....	1	1
N4	9550-141-001	Shield, Motor .....	1	1
N5	9545-008-006	Screw, Guard Panels .....	21	21
N6	9142-039-001	Elbow, Exhaust - 8" .....	1	1
N7	9109-101-001	Pipe - 8" .....	1	1
N8	9810-018-001	Tee Assy, Recirculating .....	1	1
*	9125-002-001	Damper, Backdraft .....	1	1
*	9451-146-002	Pin, Damper .....	1	1
*	8520-141-000	Nut, Spring .....	2	2
N9	9043-022-001	Boot, Recirculating .....	1	1
N10	9545-008-006	Screw, Rec. Mtg. ....	8	8
*	9074-236-001	Cover, Cabinet Top .....	1	1
*	9545-008-006	Screw, Cabinet Cover .....	8	8

\* NOT ILLUSTRATED

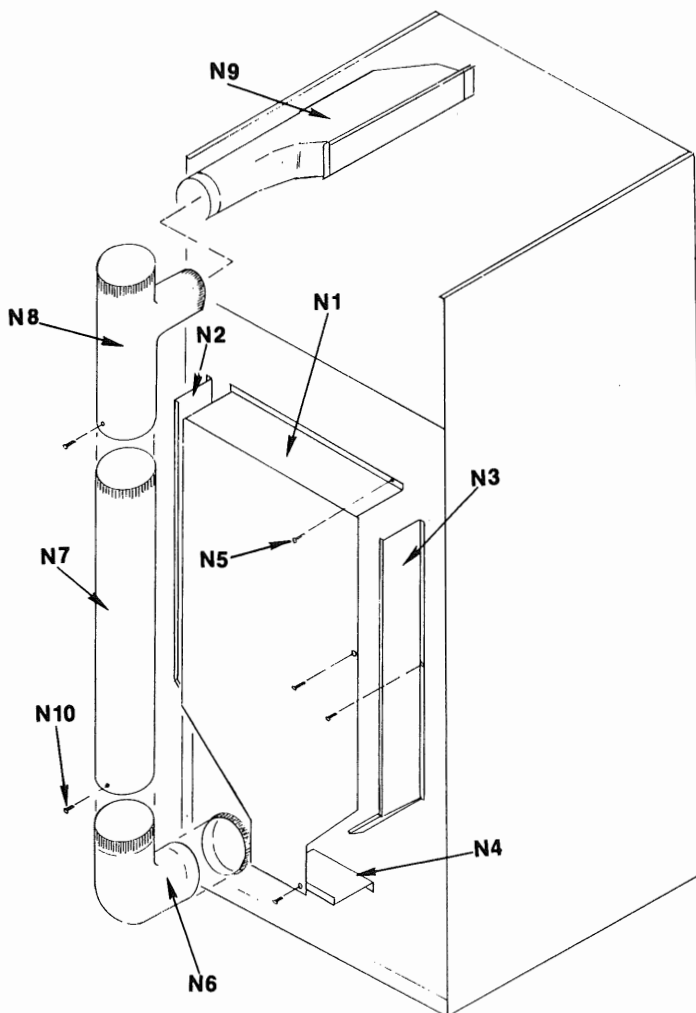

**BACK GUARDS & HEAT RECIRCULATING SYSTEM**  
**Fig. 5-12**

**WIRING GROUP**

<b>Part Number</b>	<b>Description</b>	<b>Qty.</b>
8640-276-003	Wire Nut . . . . .	5
8653-074-001	Wire, Terminal, Control Relay . . . . .	1
8220-001-198	Wire, Junct. Box to Term. Block - WH. . . . .	1
8220-001-199	Wire, Junct. Box to Motor - WH. . . . .	1
8220-001-200	Wire, Junct. Box to Motor - R. . . . .	1
8220-001-205	Wire, Junct. Box — Customer Connection - WH. . . . .	1
8220-001-206	Wire, Junct. Box to Hi-Limit - BR. . . . .	1
8220-001-208	Wire, Junct. Box to Damper Sw. - GY. . . . .	1
8220-001-219	Wire, Junct. Box to Term. Blk. - BK. . . . .	1
8220-001-220	Wire, Junct. Box to Run Relay - R. . . . .	1
8220-001-221	Wire, Term. Block to Door Switch - BK. . . . .	1
8220-001-222	Wire, Term. Block to Door Switch - BU. . . . .	1
8220-001-224	Wire, Junct. Box to Hi-Limit - Or. - BK. . . . .	1
8220-001-225	Wire, Transformer to Fuse - R. . . . .	1
8220-034-001	Wire, Junct. Box to Damper Sw. - BR. . . . .	1
8220-034-002	Wire, Junct. Box to Term. Block - BU. . . . .	1
9631-382-001	Wire, Junct. Box to Motor - BU. . . . .	1
9631-382-002	Wire, Junct. Box to Term. Block - Gy. . . . .	1

**— WIRES ARE NOT ILLUSTRATED —  
REFER TO WIRING DIAGRAM**





