



ON-PREMISE LAUNDRY T-170 EXPRESS DRYER



T-170 EXPRESS DRYER

Dexter On-Premise 6-Cycle Dryer

On-premise laundry solutions you can depend on.

Dexter on-premise dryers are engineered to show up for work in even the harshest laundry environments. Featuring flexible controls and high quality materials, these fast and efficient dryers are designed to help you process laundry faster and more efficiently.

When your business depends on clean laundry, choosing the right equipment is an important decision. Our products will provide you the efficiency, flexibility, performance, and durability you need to be confident in your choice. With lifetime technical support and an industry leading 5-year limited warranty, you can be confident that we will stand behind every dryer you invest in.

Contact your Dexter Authorized Distributor today for more details.

EFFICIENT:

Perforated tumblers and balanced radial airflow provide maximum efficiency.

The anti-wrinkle feature offers an intermittent tumble to keep laundry wrinkle free.

DURABLE:

With heavy-duty bearings in a cast iron bearing housing and a fully welded and painted cabinet, Dexter dryers are built to last.

Using proven washer-style technology, welded steel spider assemblies support the tumbler from the rear and eliminate the need for front support rollers.

Welded in tumbler baffles are strong and stable while providing great tumbling action.

RELIABLE:

Our industry leading 5-year warranty covers the trunnion, bearings, and bearing housing.

A 3-year parts warranty covers the rest.

We stand behind every machine you invest in with lifetime technical support.

FLEXIBLE:

The reversible door option on all on-premise single dryers allows for a more ergonomic set up when needed.

This dryer features a reversing tumbler to prevent roping, which sometimes occurs with large linens.

The 6-cycle control is a simple control with five preset cycles and one temporary cycle to fit your laundry needs.

INSTALLATION:

A next generation variable frequency drive lowers electrical usage, improves performance, and extends the life of the motor.

The top panels and burner housing on this dryer can be easily removed and reassembled for installation in areas with low overhead clearance.

The hinged lower service door makes cleaning the lint screen quick and easy.

OPTIONS:

This dryer is a reversing model.

Available with galvanized tumblers and white or stainless panels.

T-170 EXPRESS DRYER SPECIFICATIONS

Capacity:

Dry Weight Capacity - lb (kg)	170	(77.1)
Cylinder Volume - cu ft (L)	50	(1415.8)

Speed:

Tumbler Speed - RPM	32.5	
Motor Size - 60 Hz Model - hp (kW)	2 & 3	(1.5 & 2.2)

Airflow:

60 Hz Model - 12" Outlet - cfm (M3/min)	1900	(53.8)
---	------	--------

Dimensions:

Cabinet Height - in (cm)	94	(238.8)
Cabinet Width - in (cm)	53 1/8	(134.9)
Cabinet Depth - in (cm)	63	(160)
Door Opening - in (cm)	30	(76.2)
Floor to Door Bottom - in (cm)	36 3/4	(93.3)
Cylinder Diameter - in (cm)	50 1/4	(127.6)
Cylinder Depth - in (cm)	43 1/2	(110.5)
Lint Screen Area - sq in (sq cm)	1021	(6587)

Weight:

Net Weight - lb (kg)	1361	(617.3)
----------------------	------	---------

Shipping Information:

Shipping Weight - lb (kg)	1440	(653.2)
Shipping Height - in (cm)	97 1/8	(246.7)
Shipping Width - in (cm)	54 5/8	(138.7)
Shipping Depth - in (cm)	71 3/8	(181.3)

Gas Requirements (Gas Models Only):

Gas Supply Connection - in (mm)	1	(25.4)
Natural Gas Supply (Water Column) - in (cm)	5 - 8	(12.7 - 20.3)
LP Gas Supply (Water Column) - in (cm)	11 1/2- 13 1/2	(29.2 - 34.3)

Gas Usage (Gas Models Only):

60 Hz Model - BTU/hr (kW)	400,000	(117.2)
---------------------------	---------	---------

Electrical Requirements:

Gas Models:

Model	Volts / Hz / Phase / Wiring	Circuit Breaker / Running Amps / Wire Size / Reversing
-13	208-240 / 60 / 3 / 3 wire + ground	20 / 8.5 / #12 / Reversing

Installation Recommendations:

Minimum Clearance Between Machines - in (cm)	0	(0)
Minimum Clearance Behind Machines - in (cm)	18	(45.7)
Make-Up Air Required - sq ft (sq cm)	3	(2787)
Exhaust Size - in (cm)	12	(30.5)
Max. Exhaust Back Pressure (Water Column) - in (mm)	0.3	(7.6)
Recommended Exhaust Length - ft (m) & 2 elbows	14	(4.3)

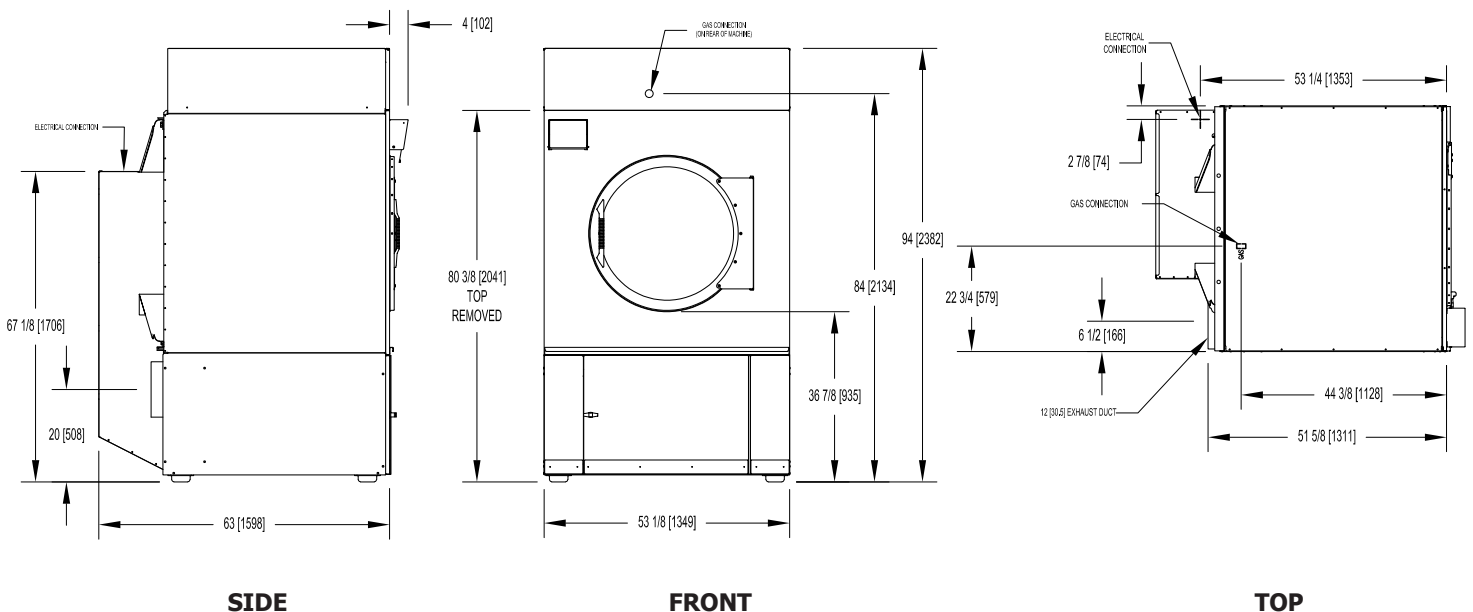

Due to continuous product improvements specifications are subject to change, please consult the installation manual for the most accurate information.
 *Agency approvals vary based on machine configuration. Major approval bodies include ETL, CE, and AGA. Dexter Laundry is ISO 9001:2015 certified.