



**DN0170NC-13EB1R**

# **Section 5:**

## **Dryer Parts Data**

# Dryer Cabinet Front Panel

Key	Description	T-170	
*	Loading Door Complete Wht/Brushed SS/Blk (#1-#9)	9960-331-003	1
1	Door Assy, Loading (Ring only) Brushed SS	9960-329-001	1
*	Door Assy, Loading (Ring & Glass only) Brushed SS (#1 & #2)	9960-330-001	1
2	Glass, Door	9212-002-006	1
*	Adhesive-Door Glass, 10.3 oz. tube (24-Hour Cure Time)	8561-138-002	1
3	Plate Assy, Hinge (Wht)	9982-398-003	1
4	Screw Hinge to Door Ring, Torx-?, 1/4-20x1/2ss	9545-015-018	5
*	Nut, Hinge to Door Ring, 1/4-20UNC, 2B	8640-414-006	5
5	Gasket, Door Outer Rim (Black)	9206-420-007	1
6	Handle, Loading Door	9244-093-001	1
*	Screw, Handle	9545-018-017	2
7	Stud Door Catch 7/8"	9531-033-002	1
8	Nut-Hex, #10-32	8640-413-001	1
9	Nut, Acorn	8640-413-003	1
*	Catch, Loading Door	9086-015-002	2
*	Rivet	9491-009-004	2
10	Strap, Hinge (Black)	9966-023-002	1
*	Chanel Assy.-Hinge back up	9947-054-001	2
*	Switch-Door (Square)	9539-501-001	1
*	Harness-Loading Door Switch	9627-948-001	1
*	Conduit-Door Switch	6068-028-001	1
*	Screw-10AB x 3/8	9545-008-024	2
*	Screw-Phillips-Counter sink, 10-32x1/2, Strap to hinge plate	9545-012-028	4
*	Screw-Phillips-, 10-32x1/2 Chrome, strap to hinge plate	9545-012-003	2
11	Screw-Special, Hinge to Door	9545-052-001	1
*	Nut-Allen, 1/4-20	8640-439-001	1
12	Washer-Fiber/Plastic	8641-436-003	1
13	Front Panel Assy (Wht)	9989-694-002	1
	Insulation-Front Panel	9277-066-001	1
14	Screw-Phillips, 10Bx1 3/4	9545-008-014	8
15	Washer-Finish	8641-585-001	8
*	Nut-Spring	8640-399-001	8
16	Screw-Torx, 10AB x 1/2", White "T-20"	9545-008-030	14
*	Fiber Washer, (attached to baffle)	8641-436-006	8
17	Screw-Torx, 10AB x 3/4", White "T20"	9545-008-035	8
18	Label-Warning	8502-753-001	1
19	Plug-Front Panel, Optional Door Switch Location	9456-055-001	1
20	Handle-Lower Front Panel	9244-095-002	1
*	Screw-10B x 3/8, Black	9545-008-010	6
*	Plug-2" (behind Control Box)	9456-041-009	1
21	Switch Assembly-Membrane	9801-103-001	1
*	Cabinet Touch Up Paint (White)	9472-001-013	1

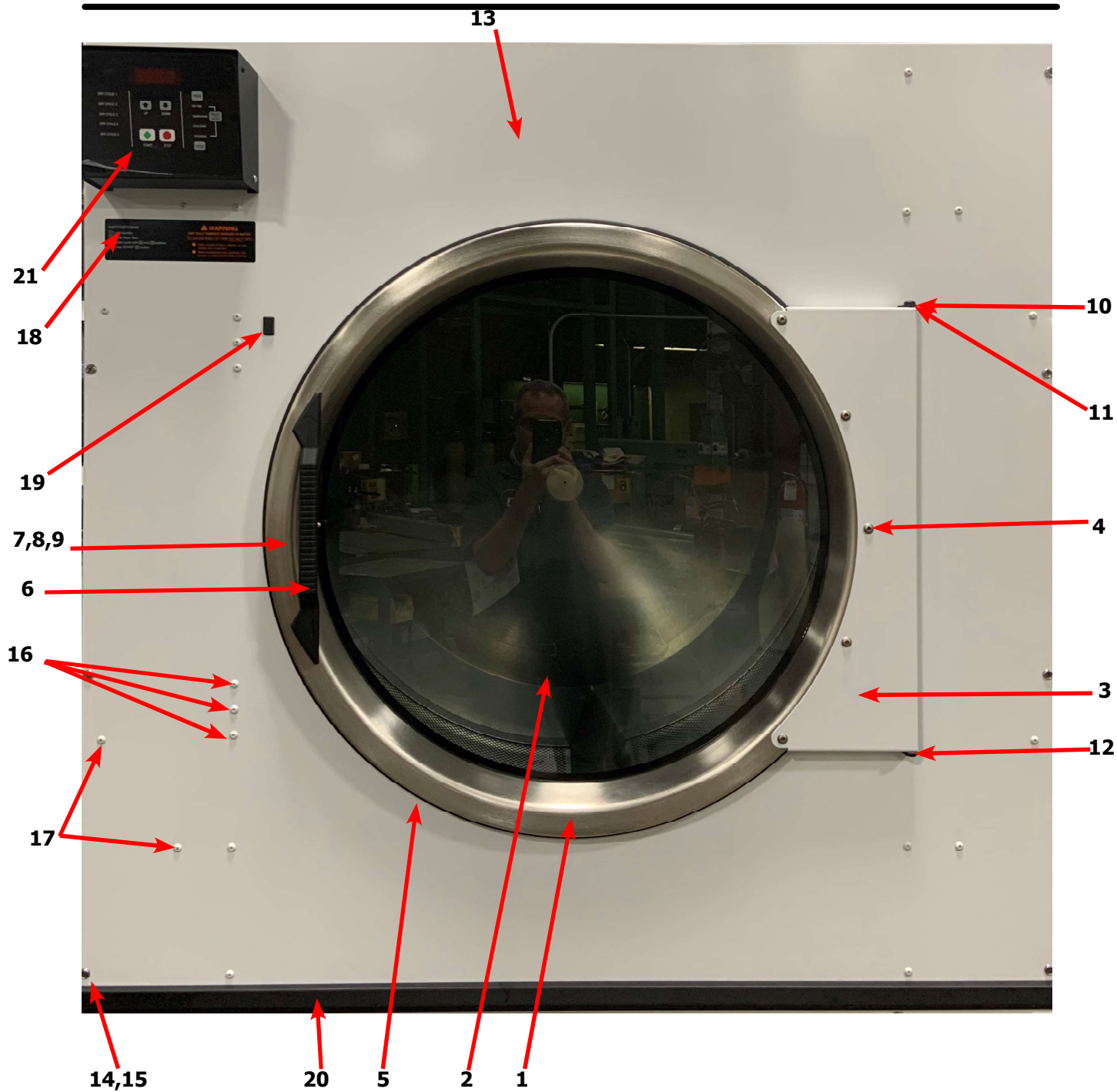

## Dryer Cabinet Group Continued

Key	Description	T-170	QTY
1	Nameplate - Dexter Dryer Black	9412-216-001	1
2	Door Assy-Upper, OPL (Wht)	9960-333-002	1
3	Screw-Phillips, 10Bx1 3/4	9545-008-014	2
4	Washer-Finish	8641-585-001	2
*	Nut-Spring	8640-399-001	2
5	Bracket-Upper Service Door (pivot)	9029-224-001	2
6	Rivet, 3/16 Low Profile	9491-009-001	2
7	Screw	9545-012-020	4
*	Nut	8640-413-002	4
8	Box-Control Front, Black	9041-107-002	1
9	Screw-5/16, 10ABx3/8	9545-008-024	4
10	Screw-10-32 x 1/2, Chrome	9545-012-003	2
11	Plate Assembly-Meter, Black	9982-379-002	1
12	Nut-Elastic Stop, #10-32	8640-413-004	2
13	Spacer-#6 x 1/2	9538-157-016	4
14	PCB-Controller	9732-249-001	1
15	Nut, #6-32	8640-411-001	3
16	Wire Assy-GRN, 12"	8220-060-001	1
17	Hex Nut, #6-32	8641-411-003	1
18	Screw, #10-32 x1/2 Green	9545-008-027	1
19	Lock Washer #10	8641-582-006	1
20	Fuse, .600MA/250V	8636-024-001	1
21	Membrane Switch	9801-103-001	1
22	Screw Torx-6BSD x 1/2, BLK, "T10"	9545-031-009	2
23	Harness-Control	9627-950-001	1
24	Harness-Temp Probe	9627-679-004	1
25	Plug-2"	9456-041-009	1
26	Label-Warning	8502-753-001	1

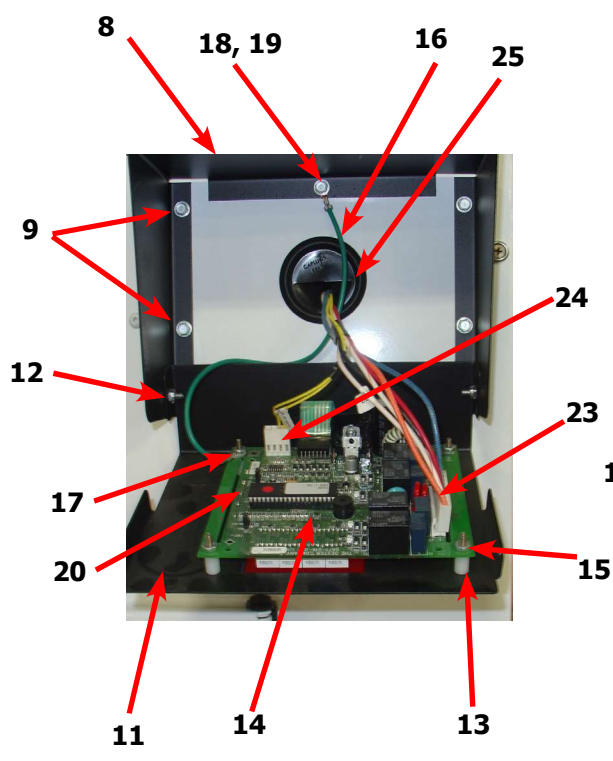
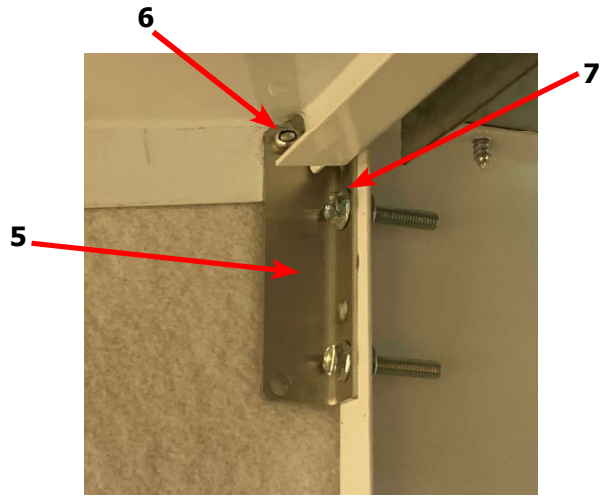
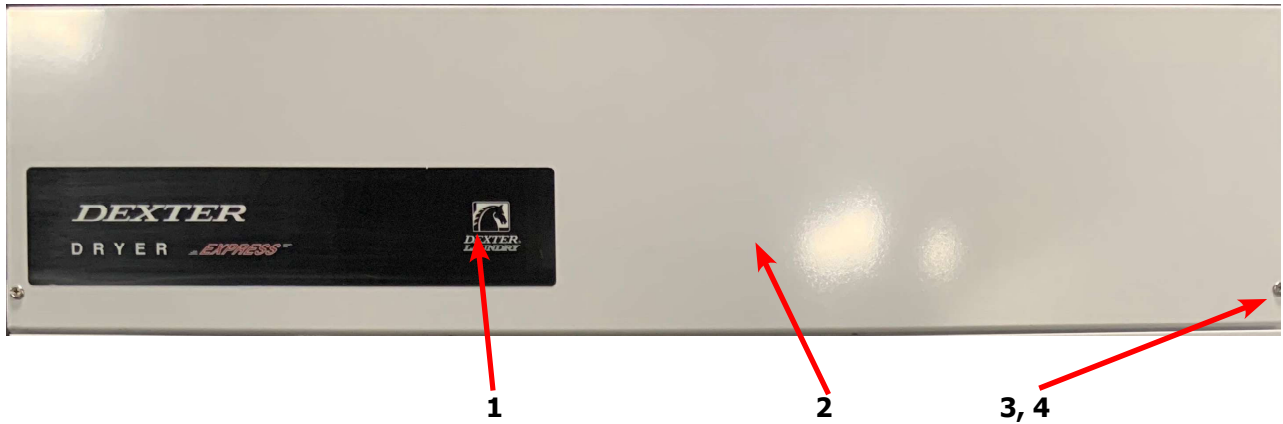

## Dryer Cabinet Group Continued

Key	Description	T-170	QTY
1	Panel-Lower Front, LH	9444-019-004	1
*	Screw-5/16, 10ABx3/8	9545-008-024	6
2	Trim-Lower Kick, Black	9578-104-002	1
3	Screw-Phollips, 10Bx3/8, Black	9545-008-010	2
*	Assembly-Door-Lower Service, OPL, Wht (4-9)	9960-332-002	1
4	Door-Lower Service, OPL, Wht	9108-150-002	1
5	Reinforcement-Lower Service Door	9489-055-001	1
6	Rivit-Blind, 1/8 Low Profile	9491-009-004	10
7	Screw-Phollips, 10Bx3/4, White	9545-008-035	4
8	Bracket-Lower Door switch	9029-226-001	1
9	Rivit-Blind, 1/8 Low Profile	9491-009-004	2
10	Trim-Lower Kick, Black	9578-103-002	1
*	Screw-Phollips, 10Bx3/8, Black	9545-008-010	4
11	Strap Assy-Hinge, lower service Door (Door)	9966-021-001	1
12	Hinge-Door, Lower	9243-084-002	1
*	Screw-5/16, 10-32x3/8	9545-012-015	4
13	Panel-Lower Front, LR	9444-019-003	1
*	Screw-5/16, 10ABx3/8	9545-008-024	6
14	Trim-Lower Kick, Black	9578-104-002	1
*	Screw-Phollips, 10Bx3/8, Black	9545-008-010	2
*	Strap Assy-Hinge, lower service Door (Cabinet)	9966-022-001	1
*	Screw-5/16, 10-32x3/8	9545-012-015	4
15	Switch-Door (Square)	9539-501-001	1
16	Handle,Turn-Door, Lower Service OPL	9244-084-002	1
*	Screen Assy, Lint	9822-034-001	1
*	Leg, Leveling 1/2"	8544-006-001	4
*	Leveling Leg Wrench	8545-061-002	1

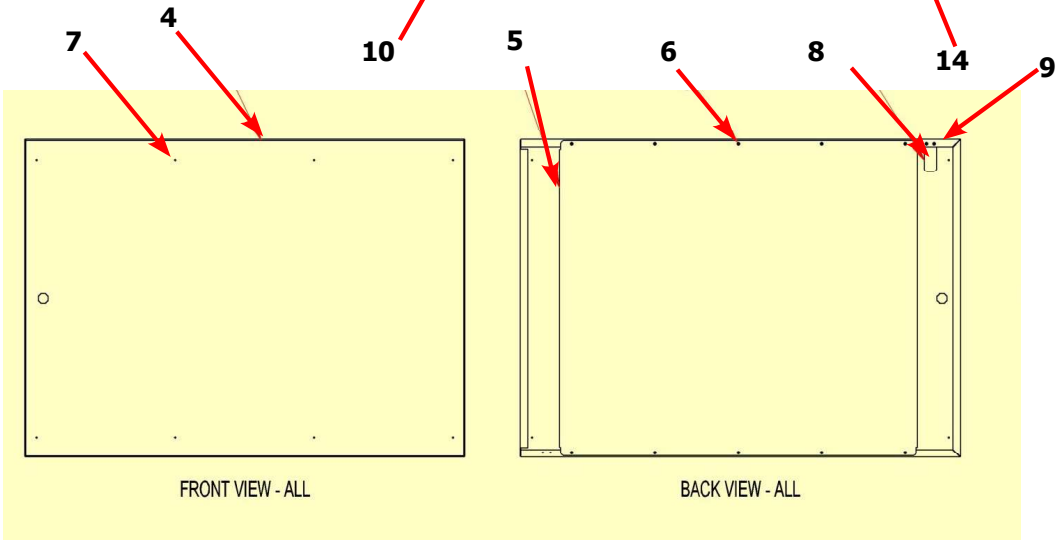
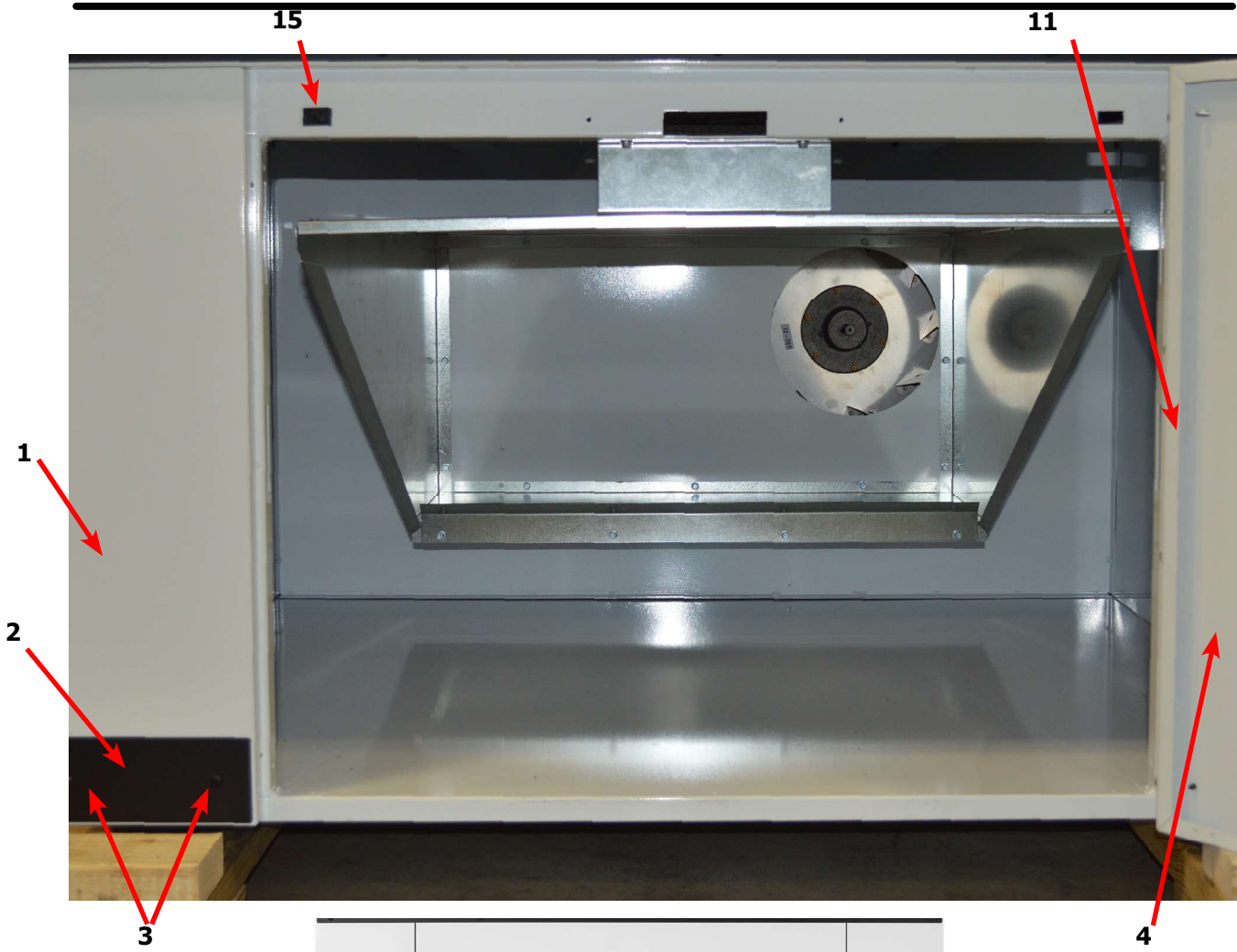

## Dryer Cabinet Group Continued

Key	Description	T-170	QTY
1	Panel Assy.-Upper Right	9989-696-003	1
*	Screw, 5/16- 10ABx3/8	9545-008-024	2
2	Insulation-Right Upper, Burner Area	9277-041-030	1
3	Panel Assy.-Upper Left	9989-697-002	1
*	Screw, 5/16- 10ABx3/8	9545-008-024	2
4	Insulation Tumbler Area, Right (Front & Back)	9277-059-001	2
4	Insulation Tumbler Area, Right (Center)	9277-059-006	1
5	Insulation Tumbler Area, Left (Front & Back)	9277-059-005	2
5	Insulation Tumbler Area, Left (Center)	9277-059-006	1
6	Switch-Door (Square)	9539-501-001	1
*	Screen Assy, Lint	9822-034-001	1
*	Lint Hood Assembly	9834-013-001	1
7	Lint Hood, Top	9240-050-001	1
*	Lint Hood, LH Side	9240-051-001	1
*	Lint Hood, RH Side	9240-051-002	1
8	Lint Hood, Bottom	9058-031-001	1
9	Lint Hood, Angle	9003-377-001	1
10	Screw, 5/16- 10ABx3/8	9545-008-024	21
11	Hinge-Door, Lower	9243-084-002	1
*	Screw-5/16, 10ABx3/8	9545-008-024	5
12	Impeller, w/set screws	9278-046-001	1
13	Harness -Temp Probe	9627-679-004	1
14	Wire Nut, #71B	8640-276-005	2
15	Temp Probe	9501-004-002	1
16	Screw-Phillips, 8Bx1/4	9545-045-005	1
17	Bracket, Temp Probe	9029-111-001	1
18	Screw, 8AB x 3/8	9545-045-008	2
19	Trim-Edge, Lint Hood	9578-092-003	2

### 170Lb. Temp Probe

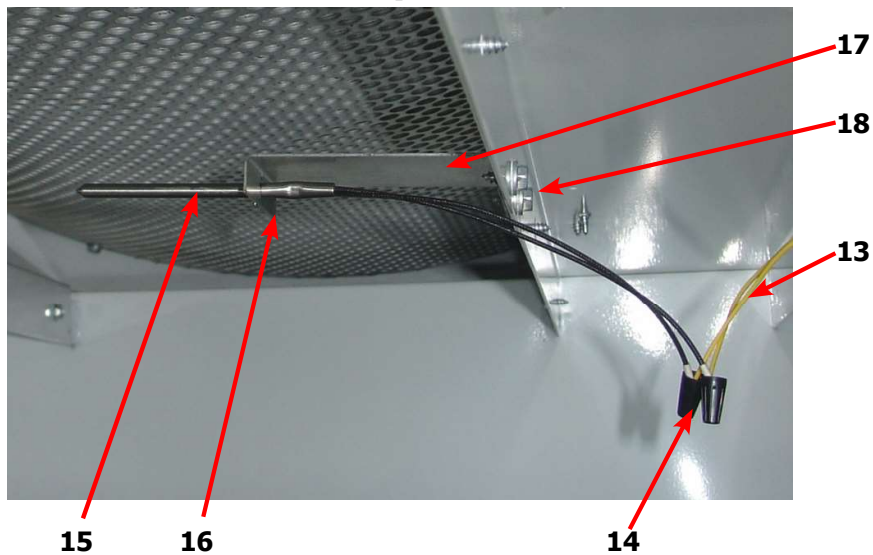



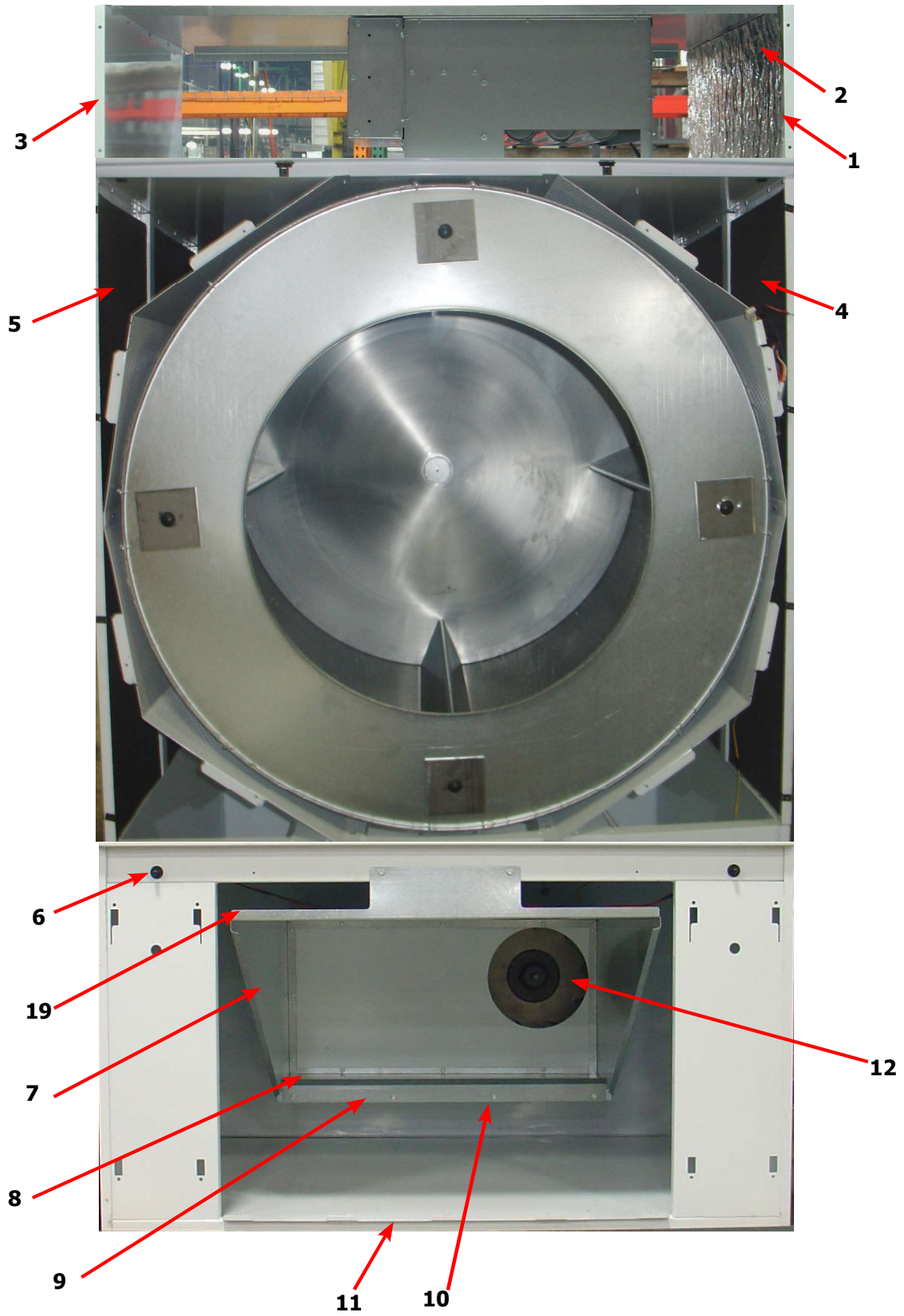

# Dryer Rear View 170Lb Reversing

Key	Description	T-170	QTY
1	Pulley, Driven	9453-173-004	1
2	Tolerance Ring	9487-234-004	1
3	Washer -Flat	8641-581-032	1
4	LockWasher - IntTooth, 1"	8641-582-018	1
5	Screw, 5/8-11 x 1 1/2	9545-060-001	1
6	Belt-Driven	9040-080-001	2
*	Impeller, 5" x 16"	9278-046-001	1
7	Plate Assembly-Impeller	9982-399-002	1
8	Nut-Wiz Lock, 5/16-18	8640-400-003	6
*	Gasket-Impeller Housing	9206-428-002	1
9	Motor-Blower	9376-337-001	1
10	Screw, 5/16-18 x 5/8	9545-014-004	4
11	Nut-Wiz Lock, 5/16-18	8640-400-003	4
12	Thermostat-Overtemp	9576-207-006	1
13	Screw-10AB x 3/8	9545-008-006	2
14	Pulley, Intermediate, w/Bearings	9908-055-001	1
*	Bearings-Ball	9036-159-011	2
*	Spacer-Bearings	9538-186-001	1
*	Ring-Retaining, Internal	9487-238-006	1
15	Washer-Flat	8641-581-039	1
16	Nut, 5/8-11	8640-425-002	1
17	Belt, Motor	9040-082-001	1
18	Motor, Drive	9376-319-001	1
19	Pulley-Motor	9453-191-001	1
20	Bushing, Motor -Support	9053-074-002	2
21	Rod-Motor Mounting, Black	9497-222-008	1
22	Collar-Shaft, w/Set Screws	9076-052-002	1
23	Chain-Belt tension	9099-012-004	1
*	Hook-S Type	9248-022-002	1
24	Spring, Belt Tension	9534-151-000	1

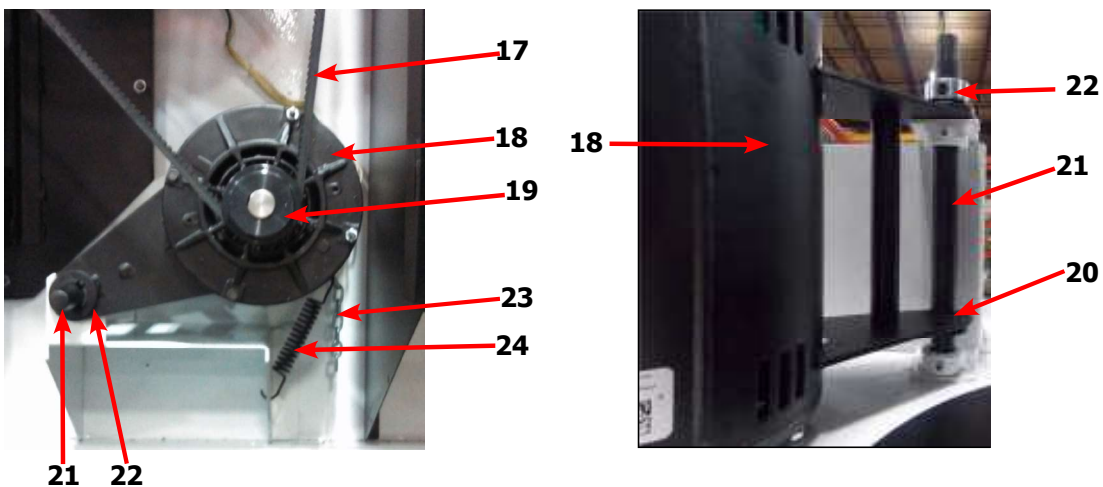

# Dryer Rear View 170Lb Reversing

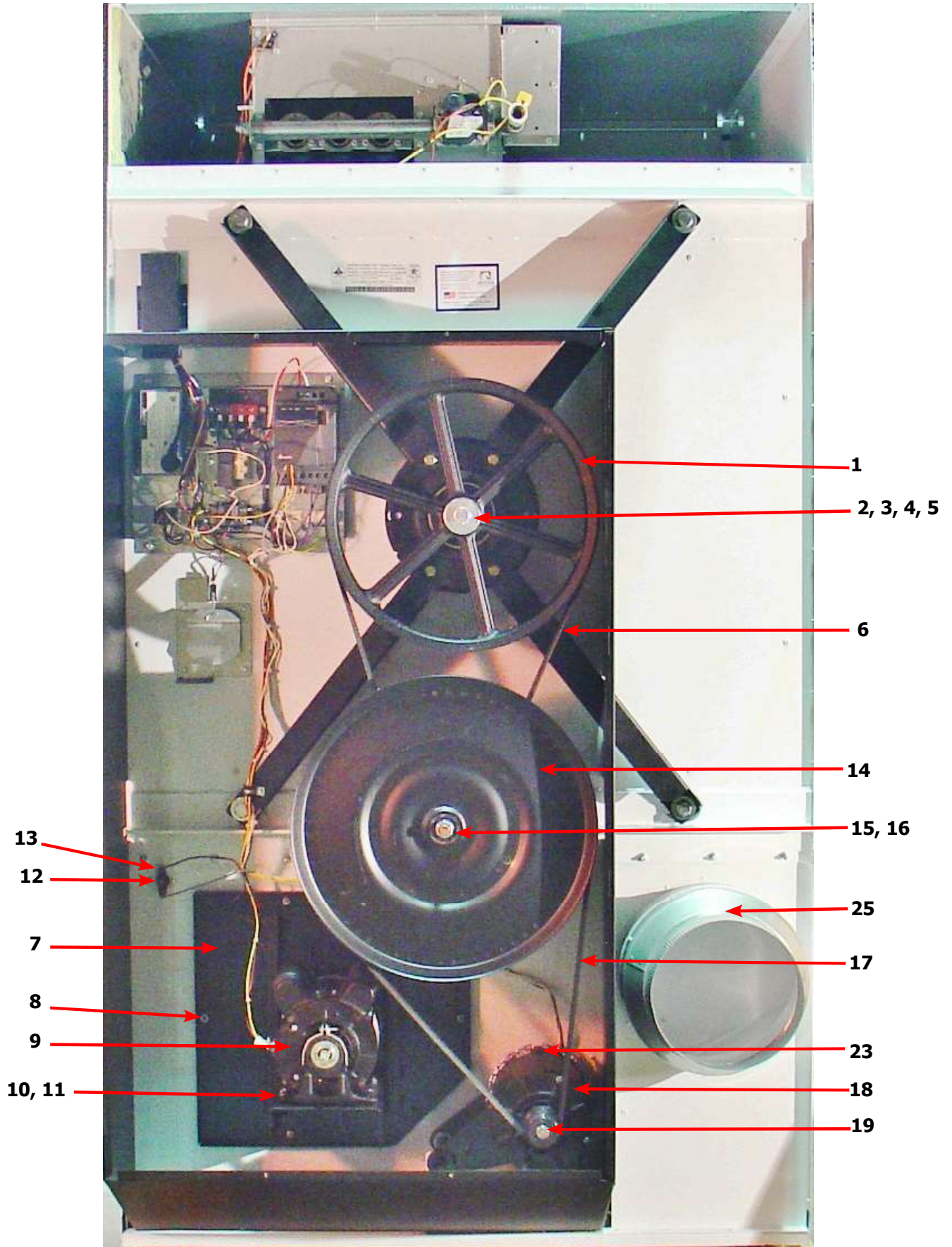

# Dryer Rear View 170Lb Reversing Continued

Key	Description	T-170	QTY
1	Pulley, Driven	9453-173-004	1
2	Tolerance Ring	9487-234-004	1
3	Washer -Flat	8641-581-032	1
4	LockWasher - IntTooth, 1"	8641-582-018	1
5	Screw, 5/8-11 x 1 1/2	9545-060-001	1
6	Plate Assembly-Intermediate, Tension	9982-378-002	1
7	Rod-Intermediate, Pivot	9497-230-002	1
8	Collar, Locking	9076-060-001	1
9	Bolt, 1/2-13 x 1 1/2	9545-017-001	2
10	Thermostat-Overtemp	9576-207-006	1
11	Screw-10AB x 3/8	9545-008-006	2
*	Impeller, 5" x 16"	9278-046-001	1
12	Plate Assembly-Impeller	9982-399-002	1
13	Nut-Wiz Lock, 5/16-18	8640-400-003	6
*	Gasket-Impeller Housing	9206-428-002	1
14	Motor-Blower	9376-337-001	1
15	Screw, 5/16-18 x 5/8	9545-014-004	4
16	Nut-Wiz Lock, 5/16-18	8640-400-003	4
17	Motor, Drive	9376-319-001	1
18	Pulley-Motor	9453-191-001	1
*	Bushing, Motor -Support	9053-074-002	2
19	Rod-Motor Mounting, Black	9497-222-008	1
20	Collar-Shaft, w/Set Screws	9076-052-002	1
21	Chain-Belt tension	9099-012-004	1
*	Hook-S Type	9248-022-002	1
*	Spring, Belt Tension	9534-151-000	1



7

8

6

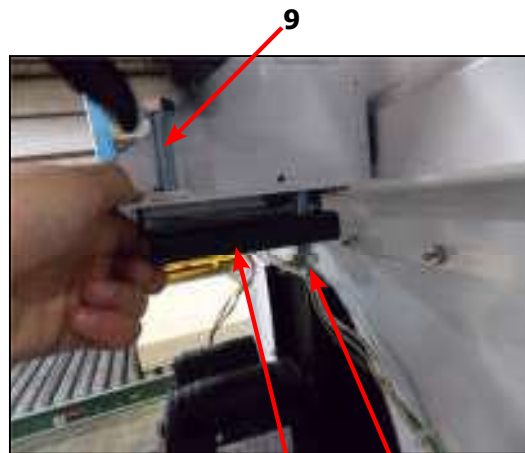

6

9

# Dryer Rear View 170Lb Reversing Continued

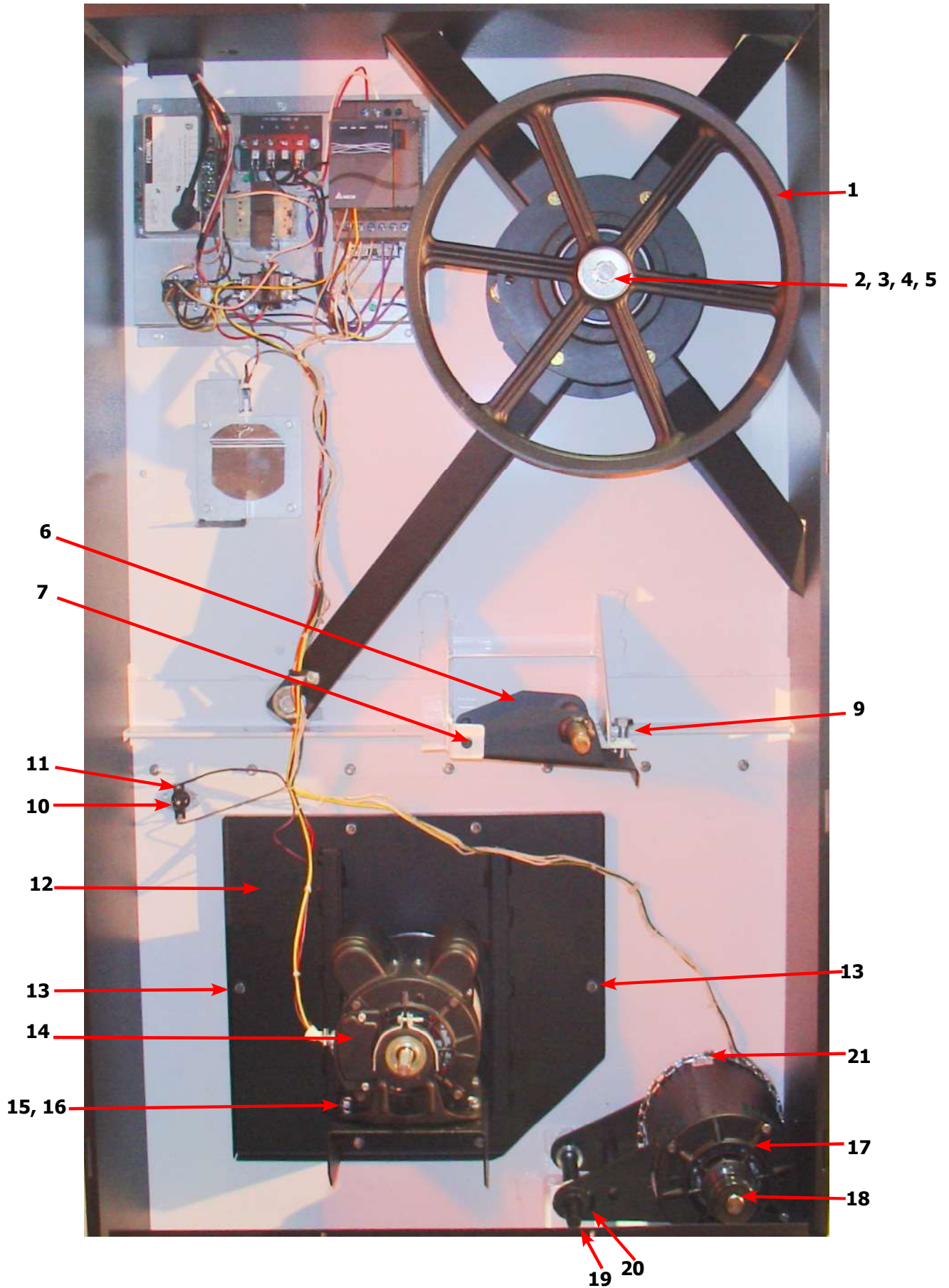

## Dryer Rear View-Guard & Exhaust

Key	Description	T-170	QTY
1	Cover Cabinet	9825-063-001	1
*	Screw-5/16, 10ABx3/8	9545-008-024	16
2	Duct-Transition, 12" to 10"	9109-124-001	1
*	Screws-10-16 x 1/2	9545-008-003	3
*	Guard-Side, Right	9208-156-002	1
*	Screw-Torx T20, 10B x 3/8, BLK	9545-008-034	7
3	Guard-Side, Left	9208-157-002	1
*	Screw-Torx T20, 10B x 3/8, BLK	9545-008-034	8
4	Guard-Top	9208-155-002	1
*	Screw-Torx T20, 10B x 3/8, BLK	9545-008-034	11
5	Guard-Bottom	9208-158-002	1
*	Screw-Torx T20, 10B x 3/8, BLK	9545-008-034	6
6	Guard-Wires	9208-115-002	1
*	Screw-Torx T20, 10B x 3/8, BLK	9545-008-034	2
7	Guard-Door, Right	9208-159-004	1
*	Screw-Torx T20, 10B x 3/8, BLK	9545-008-034	6
8	Guard-Door, Left	9208-159-003	1
9	Screw-Torx T20, 10B x 3/8, BLK	9545-008-034	4
*	Nut-Spring, U-type	8640-399-001	4
*	Booklet-Owners	8514-262-001	1
10	Diagram & Schematics	9506-901-001	1
11	Label-Warning & Notice	8502-763-001	1
12	Label-Instructions	8502-784-001	1
14	Label-High Voltage	8502-614-004	1

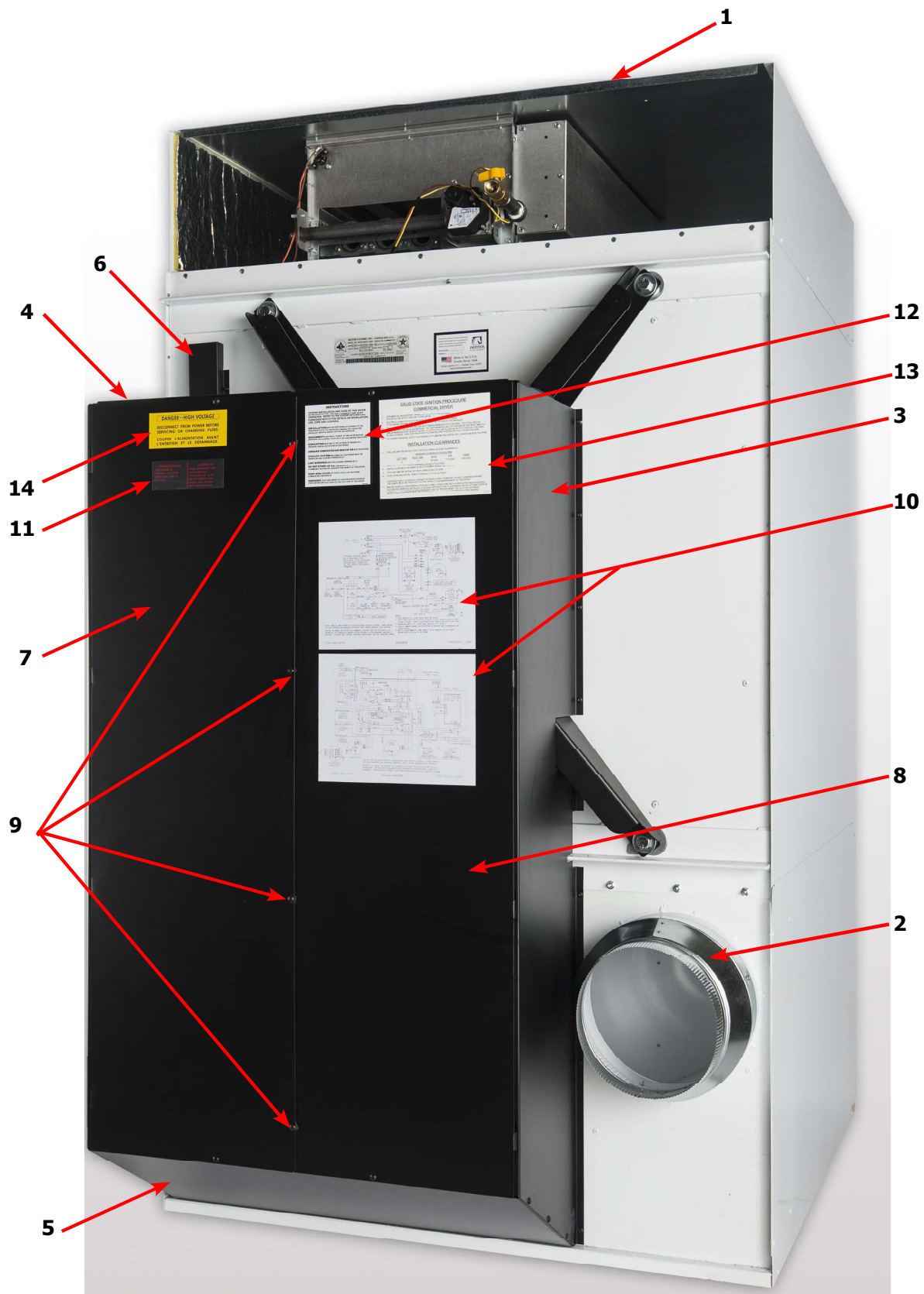

## Dryer Rear View-Bearing Housing 170Lb

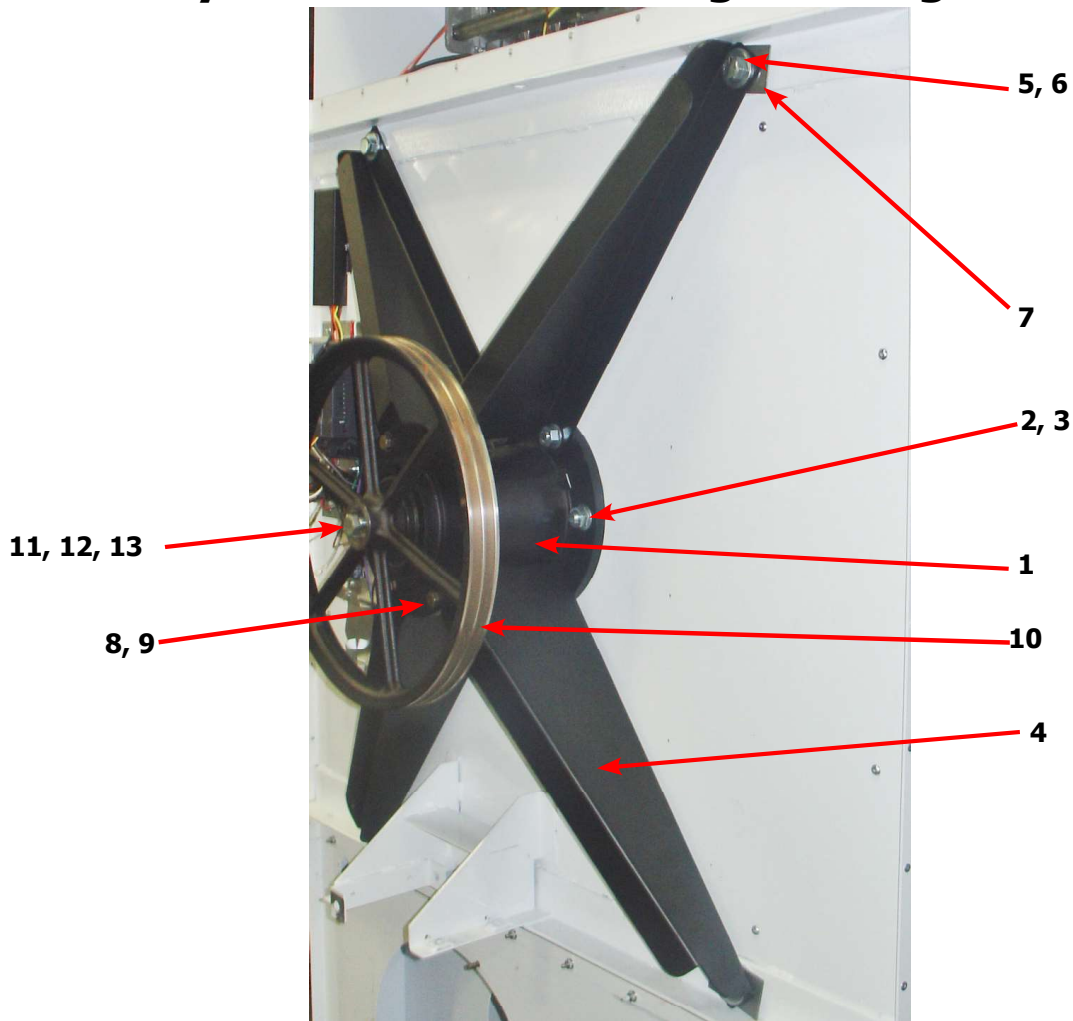

Key	Description	T-170	QTY
	Bearing Housing Complete Assy (Includes bearings & Spacer)	9803-231-001	1
1	Housing, Bearing	9241-208-002	1
*	Ring, Retaining-Internal	9487-238-004	1
*	Bearing, Ball, Front	9036-159-005	1
*	Spacer, Bearing	9538-190-001	1
*	Bearing, Ball, Rear	9036-159-006	1
*	Washer, Flat	8641-581-040	6
2	Screw-5/8"-11 x 1 1/2"	9545-060-001	6
3	Nut-Whizlock, 5/8" x 11	8640-425-001	6
4	Arm-Support Housing	9001-068-002	4
5	Screw-5/8-11 x 1 1/2	9545-060-001	4
6	Washer, Flat 5/8"	8641-581-038	4
7	Shim	9552-045-001	AR
8	Screw-7/16"-14 x 1 1/2"	9545-059-003	4
9	Nut-Whizlock, 7/16"	8640-416-005	4
*	Tolerance Ring	9487-234-004	1
10	Pulley Driven	9453-173-004	1
11	Washer, Flat 5/8" x 2 1/4"	8641-581-032	1
12	Lock Washer Spring, 1/2	8641-582-018	1
13	Screw, 5/8-11 x 1 1/2"	9545-060-001	1



# Dryer Tumbler Group 170Lb

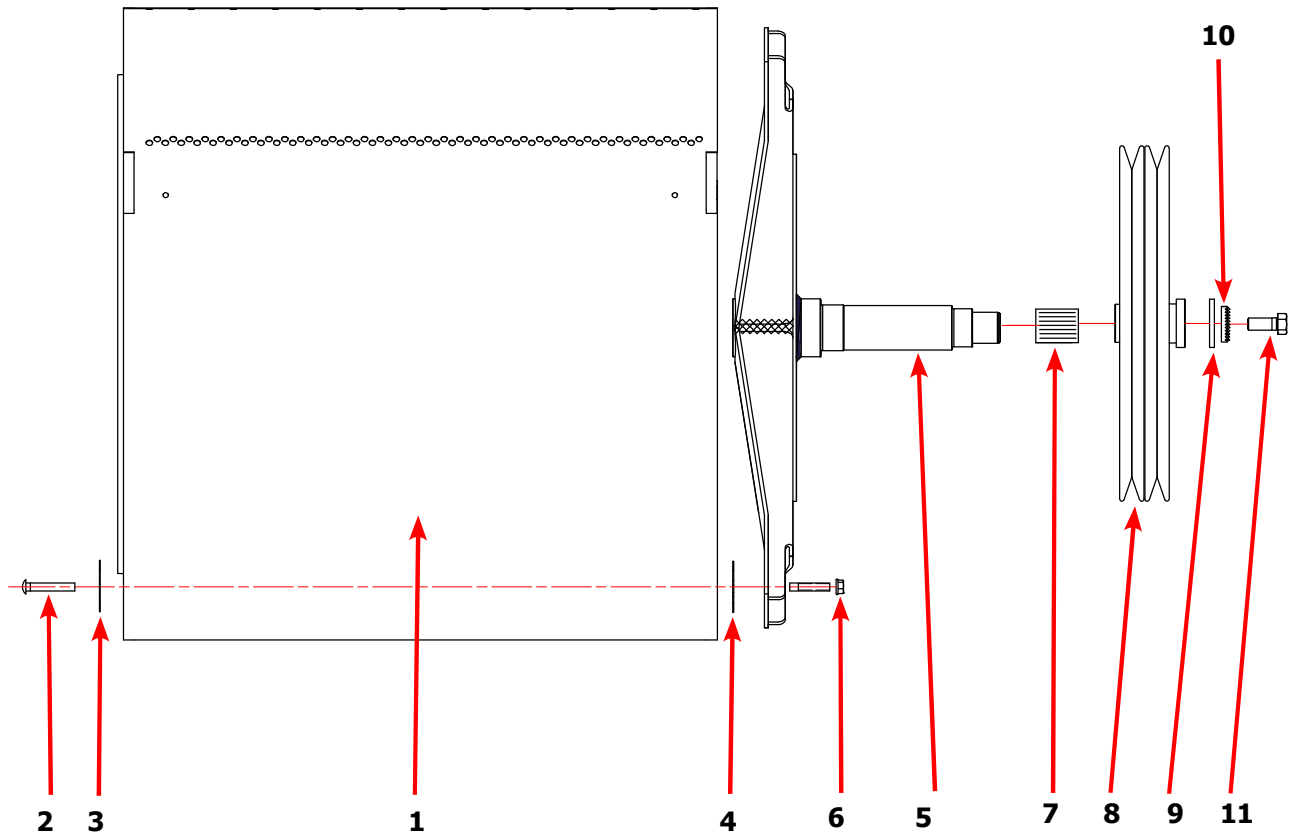

Key	Description	T-170	QTY
*	Tumbler Assy Complete W/Spider (GALV)	9848-162-001	1
1	Tumbler Assy (Galvanized)	9849-161-001	1
2	Rod, Tumbler	9497-266-004	4
3	Plate support, Tie Rod	9452-805-001	4
4	Shim	9552-013-003	AR
5	Spider Assy	9568-020-001	1
6	Nut, Wiz Lock	8640-417-005	4
7	Tolerance Ring	9487-234-004	1
8	Pulley, Driven	9453-173-004	1
9	Washer -Flat	8641-581-032	1
10	LockWasher - IntTooth, 1"	8641-582-018	1
11	Screw, 5/8-11 x 1 1/2	9545-060-001	1

# Dryer Burner Housing Group 170Lb

Key	Description	T-170	QTY
*	Housing Assembly, Burner	9803-232-001	1
1	Screw, 10ABx3/8	9545-008-024	55
2	Bracket-Support, Gas Valve	9029-329-001	1
3	Side-Extention Baffle, Burner Housing	9551-076-001	2
4	Burner, Main	9048-022-001	3
5	Baffle-Burner Housing, Extention	9049-128-001	1
6	Panel-Burner Housing, Front	9444-026-001	1
7	Panel-Burner Housing, Back	9444-025-001	1
8	Panel-Burner Housing, Side Left	9551-075-001	1
9	Baffle-Center, Burner	9049-127-001	1
10	Panel-Burner Housing, Side Right	9551-077-001	1
11	Channel-Burner Housing, Right	9081-199-001	1
12	Bracket-Manifold	9029-228-001	1
13	Bracket-Support, Burner, Front	9029-330-001	1
14	Bracket-Support, Burner, Rear	9029-331-001	1
15	Control Assy,Gas Valve, White Rodgers	9857-266-001	1
16	Manifold Assy	9381-016-001	1
17	Top Assembly, Burner Housing	9961-162-001	1
18	Screw, 10Bx1/4	9545-008-001	18
*	Orfice-Natural, #13	9425-069-028	3
*	Orfice-LP, #34	9425-069-029	3
*	Kit, LP Conversion, White Rodgers	9732-102-052	1
19	Thermostat-HI-Limit	9576-203-002	1
20	Electrode-Ignition	9875-002-003	1
21	Bracket-Igniter	9029-243-001	1
22	Elbow-1" Street, Black	8615-104-046	1

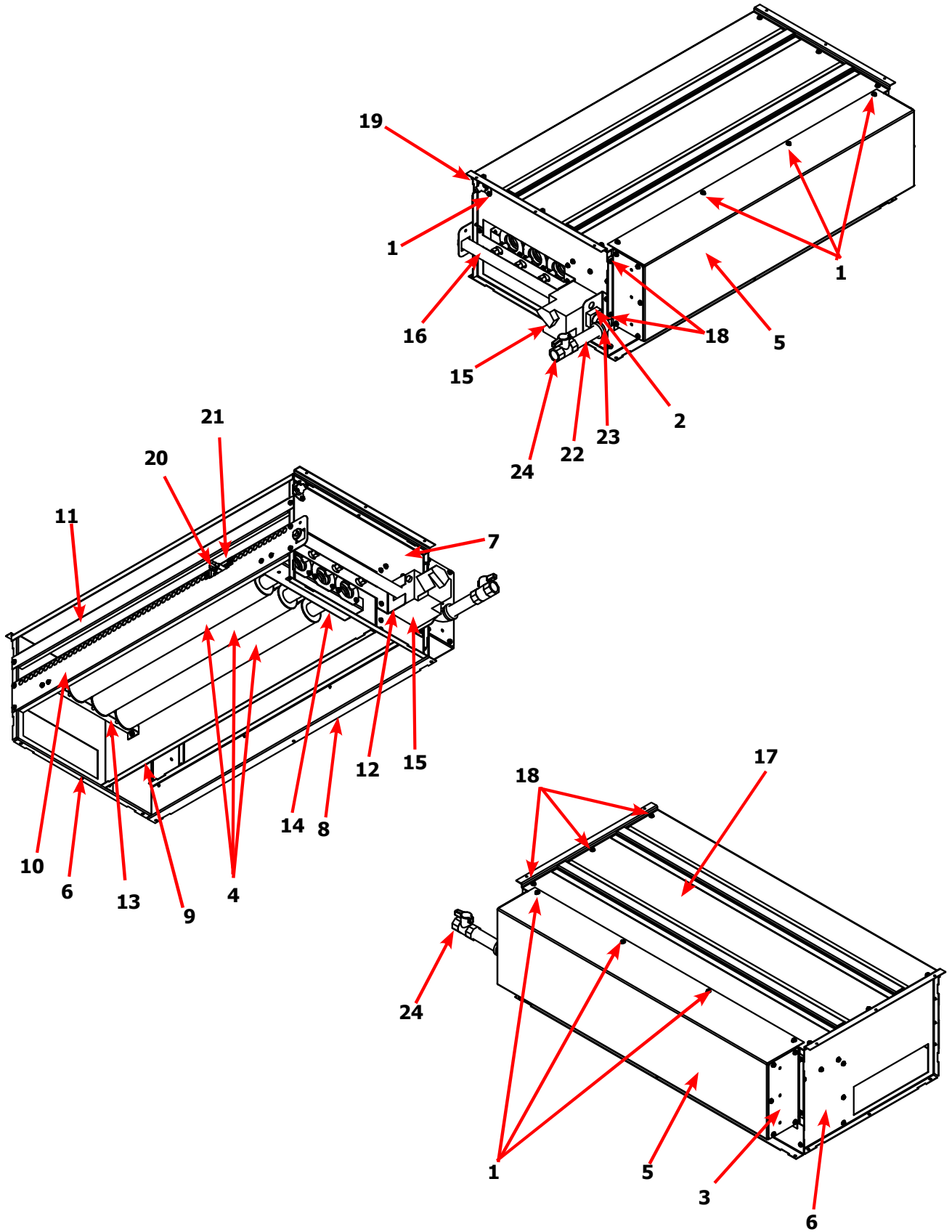

# Dryer Air Flow Swwitch Assembly

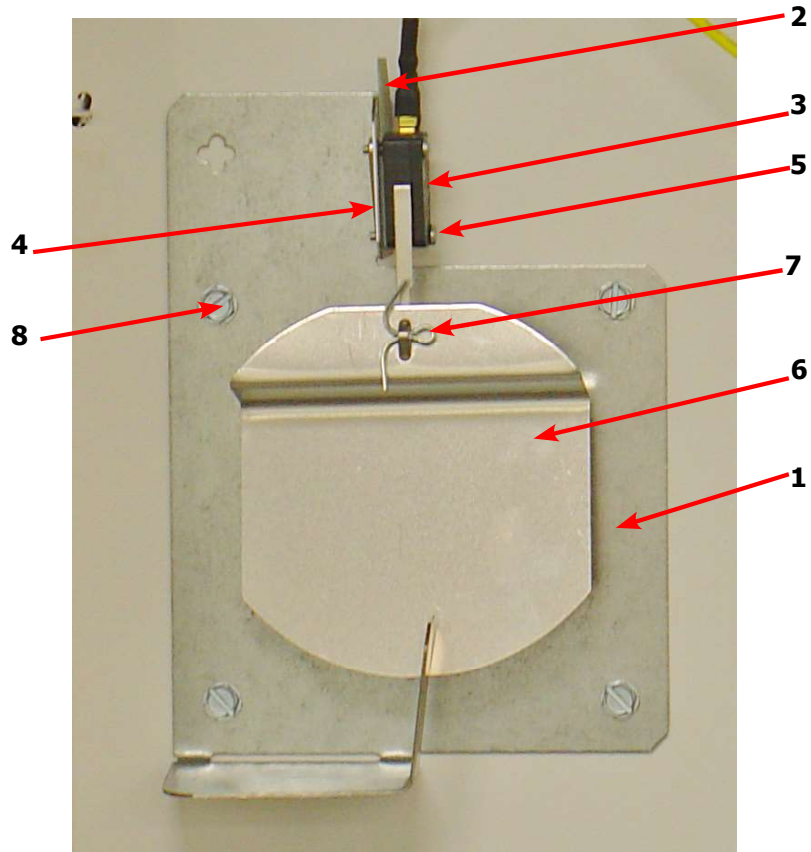

Key	Description	T-170	QTY
*	Air Flow switch Assy	9801-098-001	1
1	Bracket-Airflow switch	9029-200-001	1
2	Shield-Switch	9550-169-003	1
3	Switch-Micro	9539-461-009	1
4	Nut-Twin, 4-40	8640-401-001	1
5	Screw-.625, 4-40	9545-020-001	2
6	Actuator-Air Flow Switch	9008-007-001	1
7	Pin-Cotter, .09375x.75	9451-169-002	1
8	Screw, 10Bx1/4	9545-008-024	4

---

# Notes

A series of horizontal lines for writing notes.

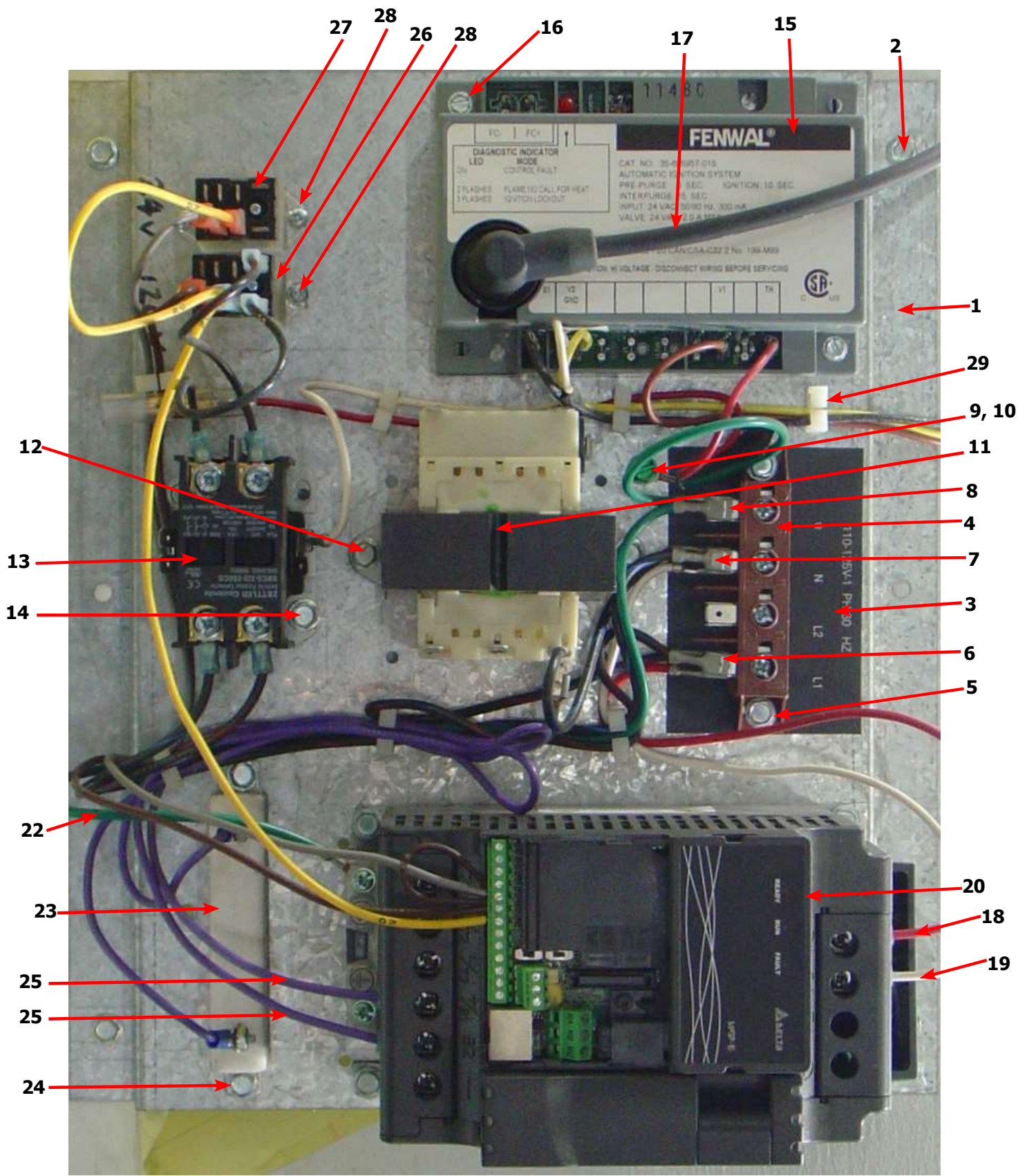

# Dryer Rear View-Control Box

Key	Description	T-170	QTY
*	Control Assembly, (1 thru 28)	9857-271-001	
1	Channel-Controls	9081-163-001	1
2	Screw, 5/16-10AB-3/8	9545-008-026	6
3	Strip-Marker, Terminal	9558-029-006	1
4	Terminal Block Assy-Power, 4Pole	9897-035-001	1
5	Screw, 5/16-10AB-3/8	9545-008-024	2
6	Wire assy-Blk/Red, 8 1/2"	8220-001-230	1
7	Wire assy-Blk/Blu, 6 1/2"	8220-001-231	1
8	Wire Assy, GRN, 7"	8220-001-478	1
9	Screw- 10-32TTx1/2 GRN	9545-008-027	2
10	Lockwasher, External tooth	8641-582-006	2
11	Transformer, w/Circuit braker	8711-007-002	1
12	Screw, 5/16-10AB-3/8	9545-008-024	2
13	Relay-Motor, 30Amp, 24VAC		1
14	Screw, 5/16-10AB-3/8	9545-008-024	2
*	Wire assy-Blk/Red, 15"	8220-146-003	2
*	Wire assy-Blk/Blu, 15"	8220-146-004	2
15	Control Assy, Ignition (Module)	9857-182-001	1
16	Screw-8Bx3/4"	9545-045-007	2
*	Harness, Ignition Module	9627-867-010	1
17	Wire Assy- High Voltage Lead	9631-403-005	1
18	Wire Assy-Red, 12"	8220-067-004	1
19	Wire Assy- White, 12"	8220-067-003	1
20	Drive-VD Inverter, 1HP, 120VAC	9375-032-022	1
PS	Key Pad, Delta E-Drive	9150-044-001	1
21	Screw-#10B x 1/2	9545-008-026	4
22	Wire Assy-Green, 18"	8220-092-006	1
*	Wire Assy-BRN, 19"	8220-078-019	1
*	Wire Assy-Yellow, 20"	8220-082-002	1
*	Wire Assy-Gray, 18"	8220-078-018	1
*	Wire Assy, Brown 3"	8220-057-035	1
23	Resistor-Dynamic Breaking, 2000HM	9483-004-002	1
24	Screw-5/16, 10ABx3/8	9545-008-024	2
25	Wire Assy, Violet 24"	8220-118-001	2
26	Relay, 120VAC		1
27	Relay, 24VAC		1
28	Screw, 6B x 3/8	9545-031-005	4
*	Wire Assy-BLK/BLU, 15"	8220-150-002	1
*	Wire Assy-BLK/RED, 12"	8220-150-001	1
*	Harness, Control	9627-770-001	1
29	Stand off	9527-007-001	7

# Wiring Schematic

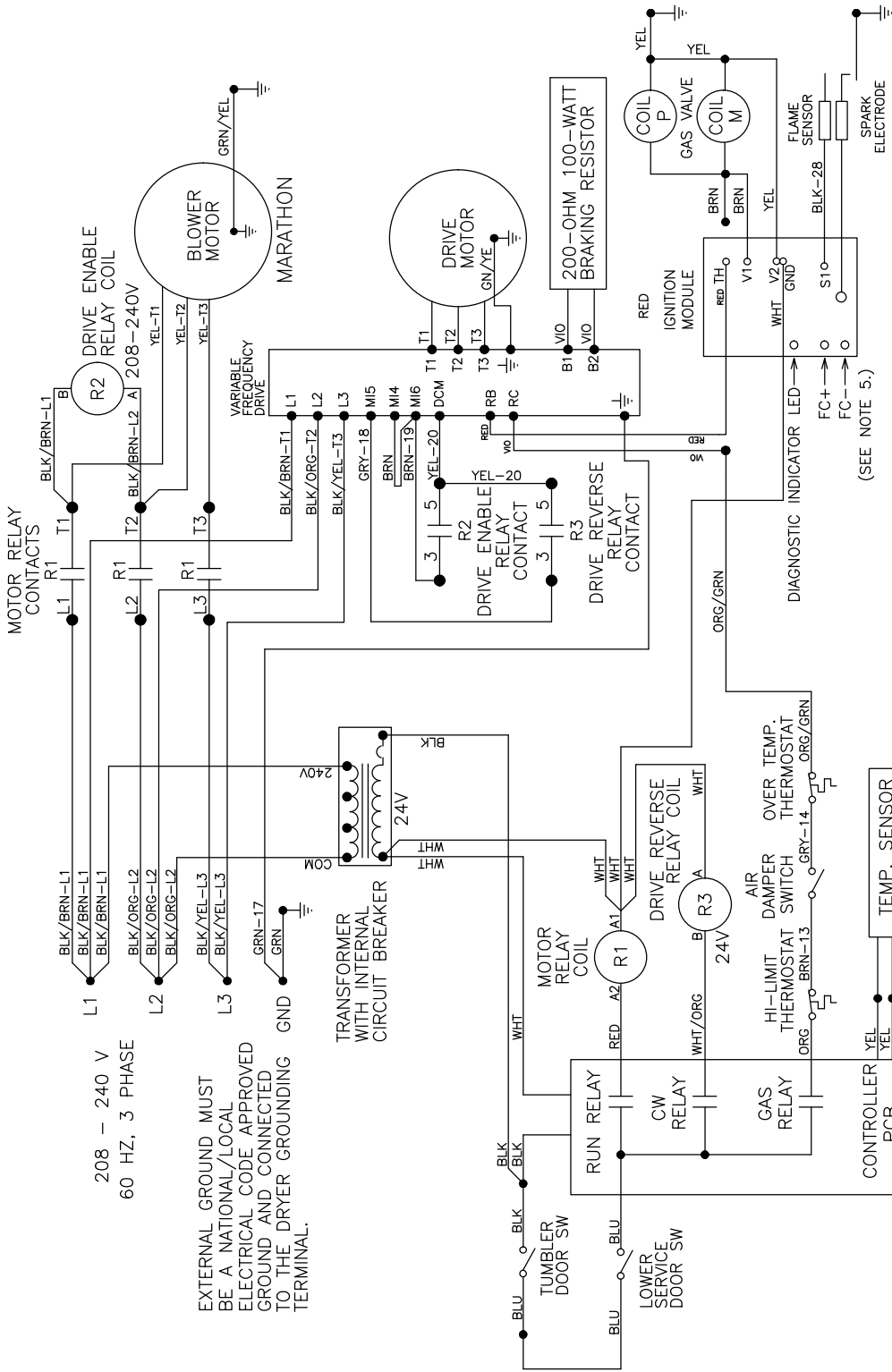

- NOTES:**
- DOOR SWITCHES—N.O., CLOSED WHEN DOORS ARE CLOSED.
  - DRYER STARTS WHEN THE DOORS ARE CLOSED, A CYCLE IS SELECTED, AND THE START BUTTON IS PUSHED. THERE IS AN AUTOMATIC COOL DOWN AT THE END OF THE CYCLE.
  - REFER TO OWNER'S MANUAL FOR DESCRIPTION OF OPERATION AND REQUIREMENTS FOR HEATING CIRCUIT.
  - WITH A DC MICROAMMETER, FLAME CURRENT CAN BE MEASURED AT TEST POINTS. READING SHOULD BE 0.7uA DC OR HIGHER.
- CAUTION:** LABEL ALL WIRES PRIOR TO DISCONNECTION WHEN SERVICING CONTROLS. WIRING ERRORS CAN CAUSE IMPROPER AND DANGEROUS OPERATION. VERIFY PROPER OPERATION AFTER SERVICING.
- ATTENTION:** AU MOMENT DE L'ENTRIEN DES COMMANDES, ÉTIQUETEZ TOUS LES FILS AVANT DE LES DEBRANCHER. DES ERREURS DE CABLAGE PEUVENT ENTRAINER UN FONCTIONNEMENT INADEQUAT ET DANGEREUX. S'ASSURER QUE L'APPAREIL FONCTIONNE ADEQUATEMENT UNE FOIS L'ENTRIEN TERMINÉ.

9506-901-001PR                      SCHEMATIC                      DN0170N\_13\_B\_R\_-----X



# Wiring Diagram

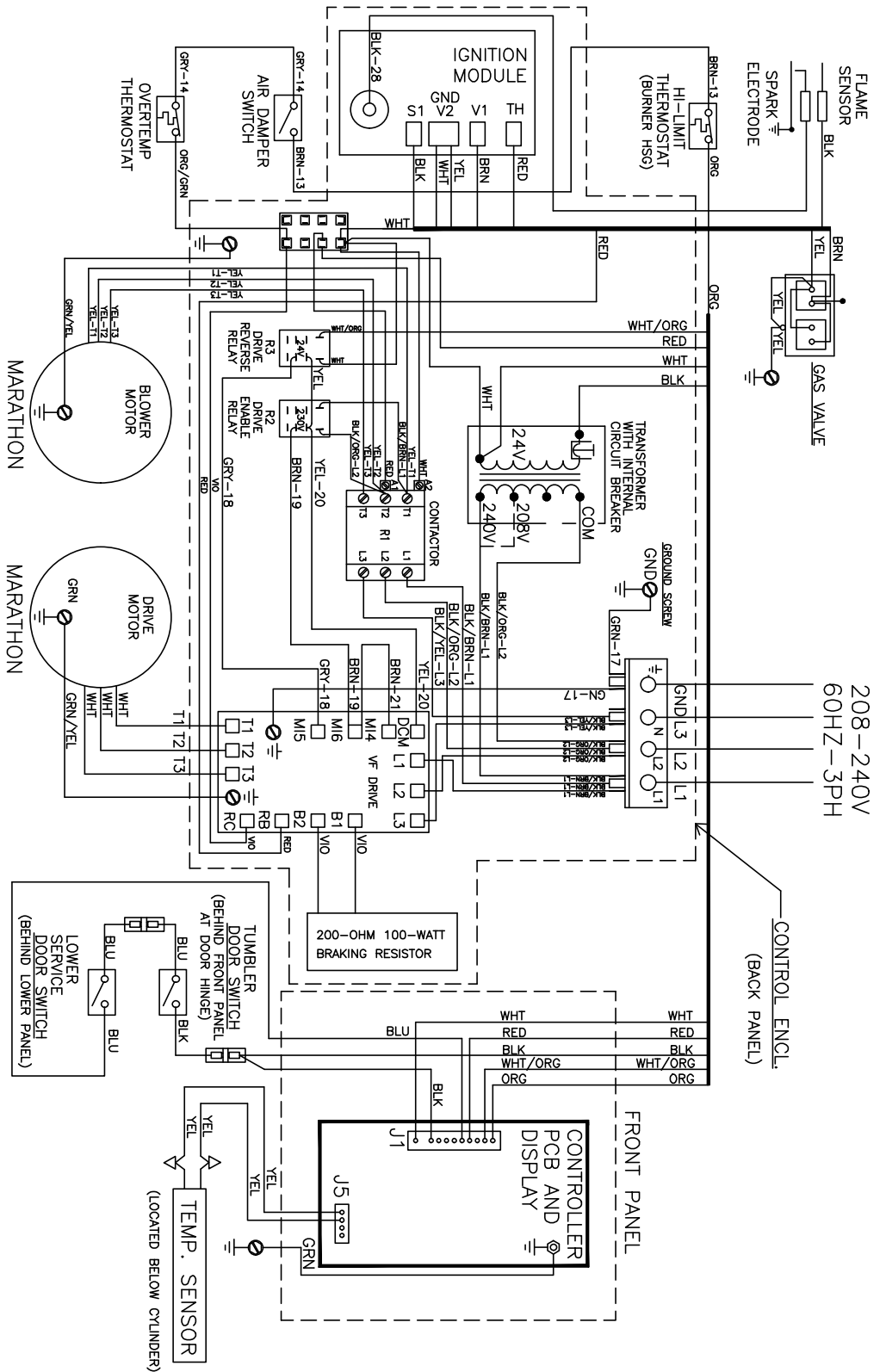

CAUTION: LABEL ALL WIRES PRIOR TO DISCONNECTION WHEN SERVICING CONTROLS. WIRING ERRORS CAN CAUSE IMPROPER AND DANGEROUS OPERATION. VERIFY PROPER OPERATION AFTER SERVICING.  
 ATTENTION: AU MOMENT DE L'ENTRIEN DES COMMANDES, ÉTIQUÉTEZ TOUS LES FILS AVANT DE LES DÉBRANCHER. DES ERREURS DE CÂBLAGE PEUVENT ENTRAÎNER UN FONCTIONNEMENT INADÉQUAT ET DANGEREUX. S'ASSURER QUE L'APPAREIL FONCTIONNE ADEQUATEMENT UNE FOIS L'ENTRETIEN TERMINÉ.

9506-901-001PR

WIRING DIAGRAM

DN0170N\_-13\_B\_R-----X

---

# Notes

Lined area for taking notes, consisting of approximately 35 horizontal lines.

---

# **Section 6:**

50Hz

Dryer Parts Data

