



DN0170NE-13E01\_

# Section 5:

## Dryer Parts Data

# Dryer Cabinet Front Panel

Key	Description	T-170	
*	Loading Door Complete Wht/Brushed SS/Blk (#1-#9)	9960-331-003	1
1	Door Assy, Loading (Ring only) Brushed SS	9960-329-001	1
*	Door Assy, Loading (Ring & Glass only) Brushed SS (#1 & #2)	9960-330-001	1
2	Glass, Door	9212-002-006	1
*	Adhesive-Door Glass, 10.3 oz. tube (24-Hour Cure Time)	8561-138-002	1
3	Plate Assy, Hinge (Wht)	9982-398-003	1
4	Screw Hinge to Door Ring, Torx-?, 1/4-20x1/2ss	9545-015-018	5
*	Nut, Hinge to Door Ring, 1/4-20UNC, 2B	8640-414-006	5
5	Gasket, Door Outer Rim (Black)	9206-420-007	1
6	Handle, Loading Door	9244-093-001	1
*	Screw, Handle	9545-018-017	2
7	Stud Door Catch 7/8"	9531-033-002	1
8	Nut-Hex, #10-32	8640-413-001	1
9	Nut, Acorn	8640-413-003	1
*	Catch, Loading Door	9086-015-002	2
*	Rivet	9491-009-004	2
10	Strap, Hinge (Black)	9966-023-002	1
*	Chanel Assy.-Hinge back up	9947-054-001	2
*	Switch-Door (Square)	9539-501-001	1
*	Harness-Loading Door Switch	9627-948-001	1
*	Conduit-Door Switch	6068-028-001	1
*	Screw-10AB x 3/8	9545-008-024	2
*	Screw-Phillips-Counter sink, 10-32x1/2, Strap to hinge plate	9545-012-028	4
*	Screw-Phillips-, 10-32x1/2 Chrome, strap to hinge plate	9545-012-003	2
11	Screw-Special, Hinge to Door	9545-052-001	1
*	Nut-Allen, 1/4-20	8640-439-001	1
12	Washer-Fiber/Plastic	8641-436-003	1
13	Front Panel Assy (Wht)	9989-694-002	1
	Insulation-Front Panel	9277-066-001	1
14	Screw-Phillips, 10Bx1 3/4	9545-008-014	8
15	Washer-Finish	8641-585-001	8
*	Nut-Spring	8640-399-001	8
16	Screw-Torx, 10AB x 1/2", White "T-20"	9545-008-030	14
*	Fiber Washer, (attached to baffle)	8641-436-006	8
17	Screw-Torx, 10AB x 3/4", White "T20"	9545-008-035	8
18	Label-Warning	8502-753-001	1
19	Plug-Front Panel, Optional Door Switch Location	9456-055-001	1
20	Handle-Lower Front Panel	9244-095-002	1
*	Screw-10B x 3/8, Black	9545-008-010	6
*	Plug-2" (behind Control Box)	9456-041-009	1
21	Nameplate - Dexter Dryer Black	9412-257-001	1
22	Control Box (Box only)	9041-107-002	1
23	Overlay control box	9435-057-001	1
24	Button Control, 2.0, OPL	9035-063-001	1

# Dryer Cabinet Front Panel

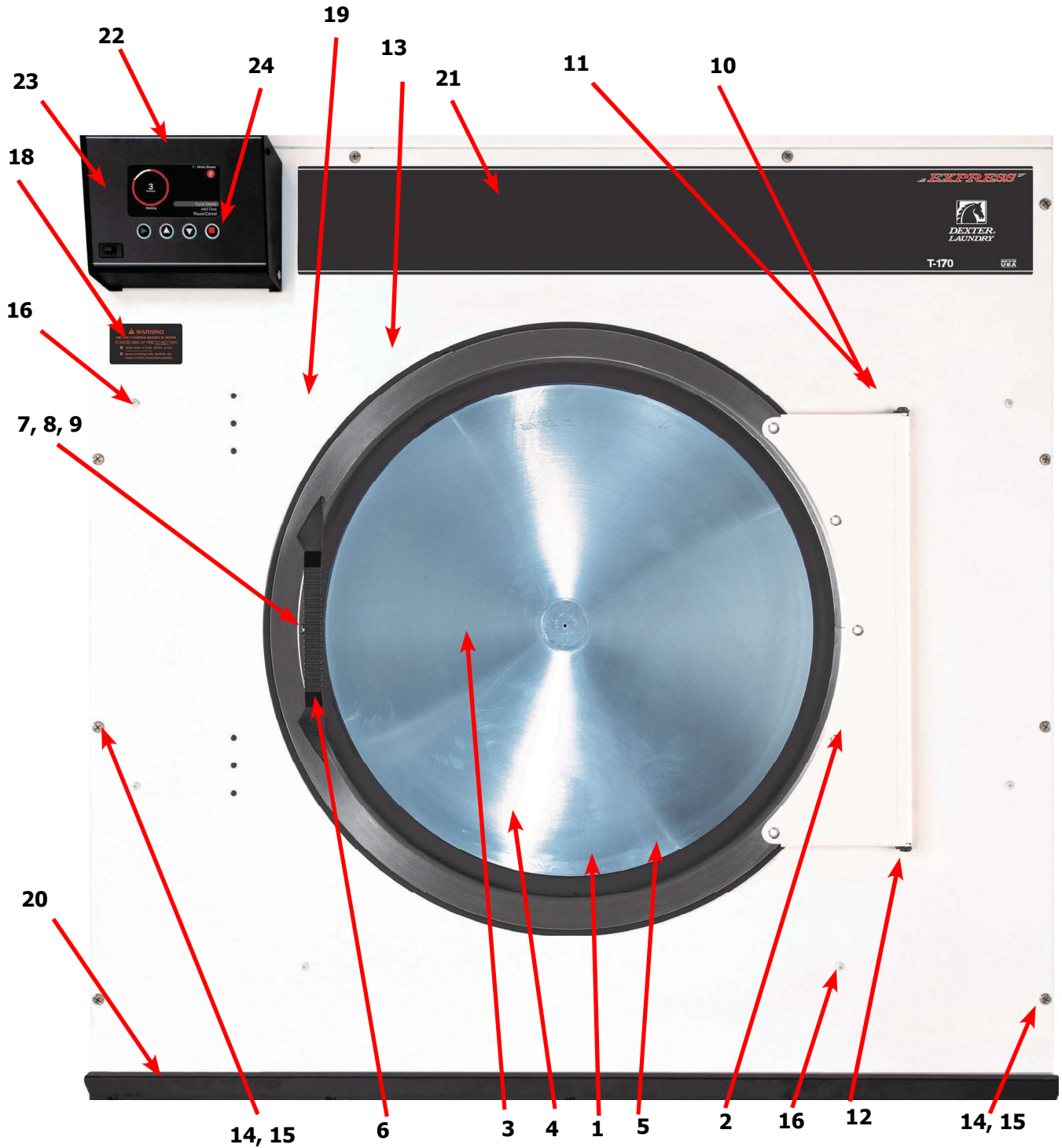

# Dryer Cabinet Group Continued

Key	Description	T-170	QTY
1	Door Assy-Upper, OPL (Wht)	9960-328-004	1
2	Screw-Phillips, 10Bx1 3/4	9545-008-014	4
3	Washer-Finish	8641-585-001	4
*	Nut-Spring	8640-399-001	4
4	Bracket-Upper Service Door (pivot)	9029-224-001	2
5	Rivet, 3/16 Low Profile	9491-009-001	2
6	Screw	9545-012-020	4
*	Nut	8640-413-002	4
7	Box-Control Front, Black	9041-107-002	1
8	Screw-10ABx3/8 (Box mounting to Front Panel)	9545-008-024	4
9	Screw-10-32 x 1/2, Chrome	9545-012-003	2
10	Nut-Elastic Stop, #10-32	8640-413-004	2
11	Plate Assembly-Meter, Black	9982-394-002	1
12	Overlay control box	9435-057-001	1
13	Button Control, 2.0, OPL	9435-057-001	1
*	Nut-Elastic Stop, #10-32	8640-413-004	2
14	Window, Display-w/gasket	9635-021-002	1
15	Display Control	9857-230-002	1
*	Nut, #6-32	8640-411-003	4
16	Screw, #10-32 x1/2 Green	9545-008-027	1
17	Lock Washer #10	8641-582-006	1
18	Wire, Green/Yellow, 12"	8220-060-001	1
19	Cable USB	9806-024-001	1
20	Cap USB	0935-141-001	1
21	Screw Torx-6BSD x 1/2, BLK, "T10"	9545-031-009	2
22	Harness-Display Control	9627-922-001	1
23	Plug-2"	9456-041-009	1
24	PCB Assy-Main Control Board	9799-027-001	1

24

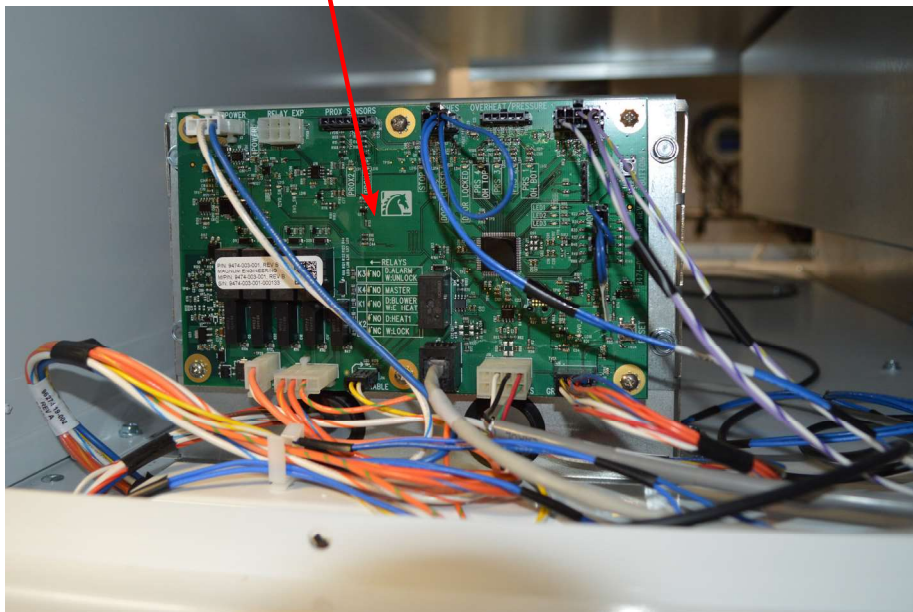

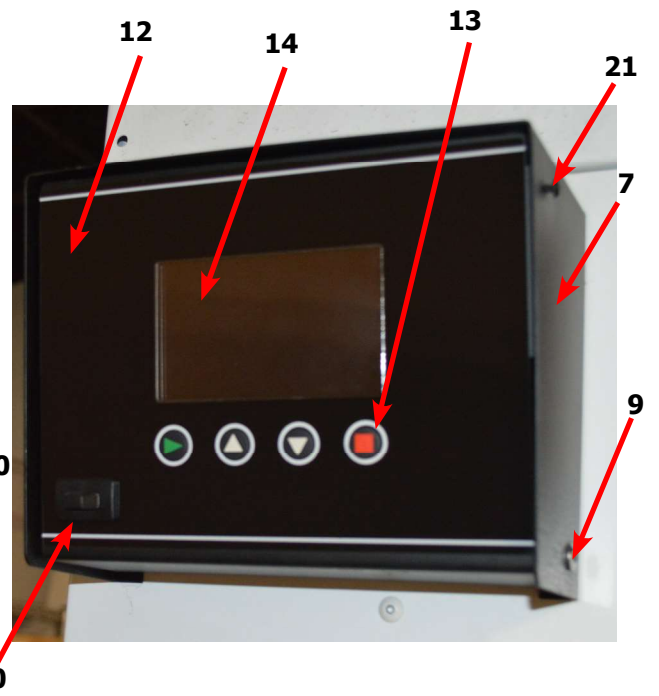
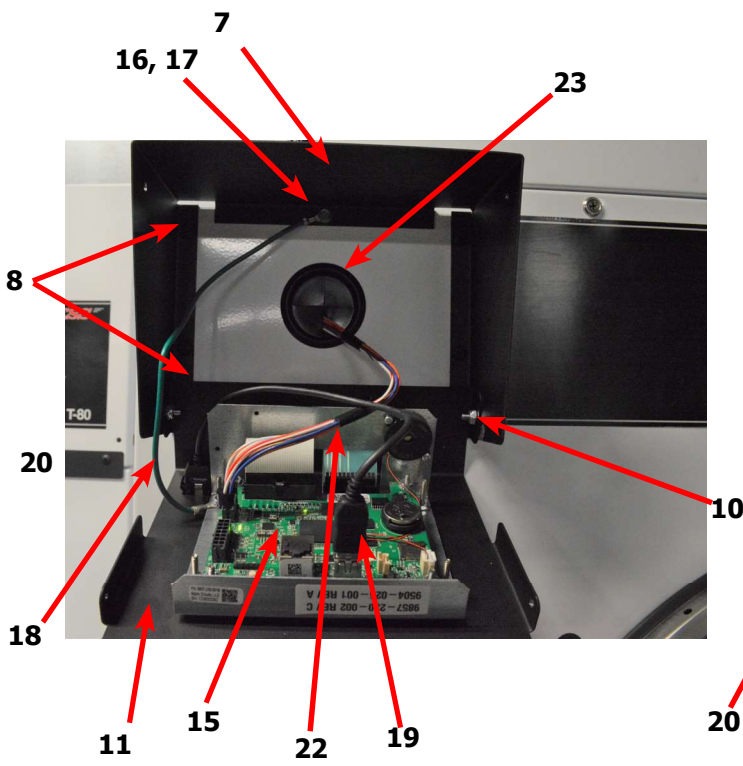
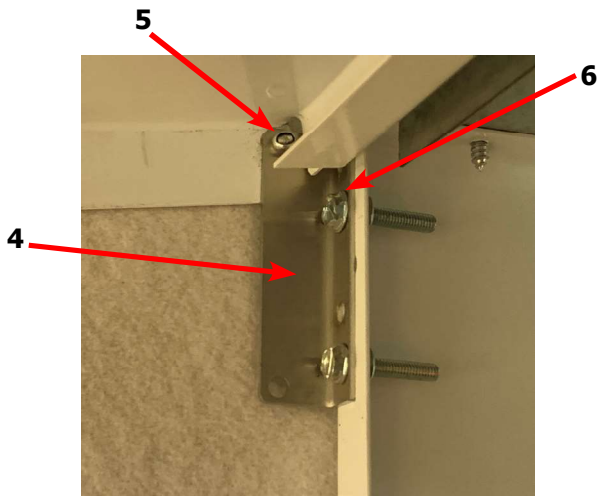
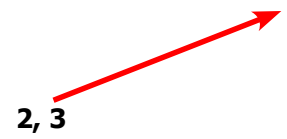

# Dryer Cabinet Group Continued

Key	Description	T-170	QTY
1	Panel-Lower Front, LH	9444-019-004	1
*	Screw-5/16, 10ABx3/8	9545-008-024	6
2	Trim-Lower Kick, Black	9578-104-002	1
3	Screw-Phillips, 10Bx3/8, Black	9545-008-010	2
*	Assembly-Door-Lower Service, OPL, Wht (4-9)	9960-332-002	1
4	Door-Lower Service, OPL, Wht	9108-150-002	1
5	Reinforcement-Lower Service Door	9489-055-001	1
6	Rivit-Blind, 1/8 Low Profile	9491-009-004	10
7	Screw-Phillips, 10Bx3/4, White	9545-008-035	4
8	Bracket-Lower Door switch	9029-226-001	1
9	Rivit-Blind, 1/8 Low Profile	9491-009-004	2
10	Trim-Lower Kick, Black	9578-103-002	1
*	Screw-Phillips, 10Bx3/8, Black	9545-008-010	4
11	Strap Assy-Hinge, lower service Door (Door)	9966-021-001	1
12	Hinge-Door, Lower	9243-084-002	1
*	Screw-5/16, 10-32x3/8	9545-012-015	4
13	Panel-Lower Front, LR	9444-019-003	1
*	Screw-5/16, 10ABx3/8	9545-008-024	6
14	Trim-Lower Kick, Black	9578-104-002	1
*	Screw-Phillips, 10Bx3/8, Black	9545-008-010	2
*	Strap Assy-Hinge, lower service Door (Cabinet)	9966-022-001	1
*	Screw-5/16, 10-32x3/8	9545-012-015	4
15	Switch-Door (Square)	9539-501-001	1
16	Handle, Turn-Door, Lower Service OPL	9244-084-002	1
*	Screen Assy, Lint	9822-034-001	1
*	Leg, Leveling 1/2"	8544-006-001	4
*	Leveling Leg Wrench	8545-061-002	1



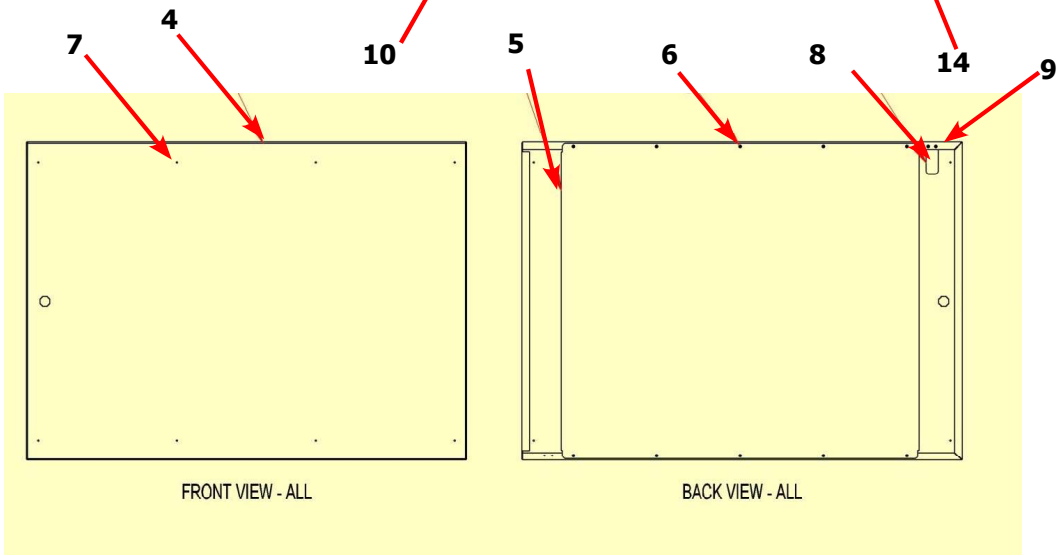
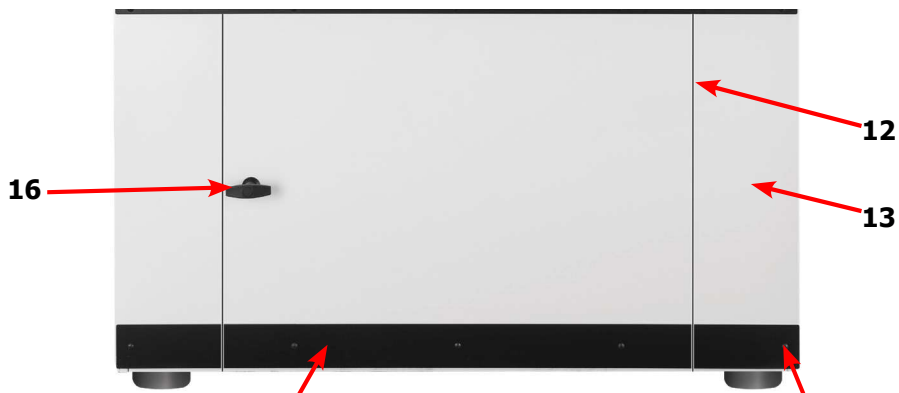
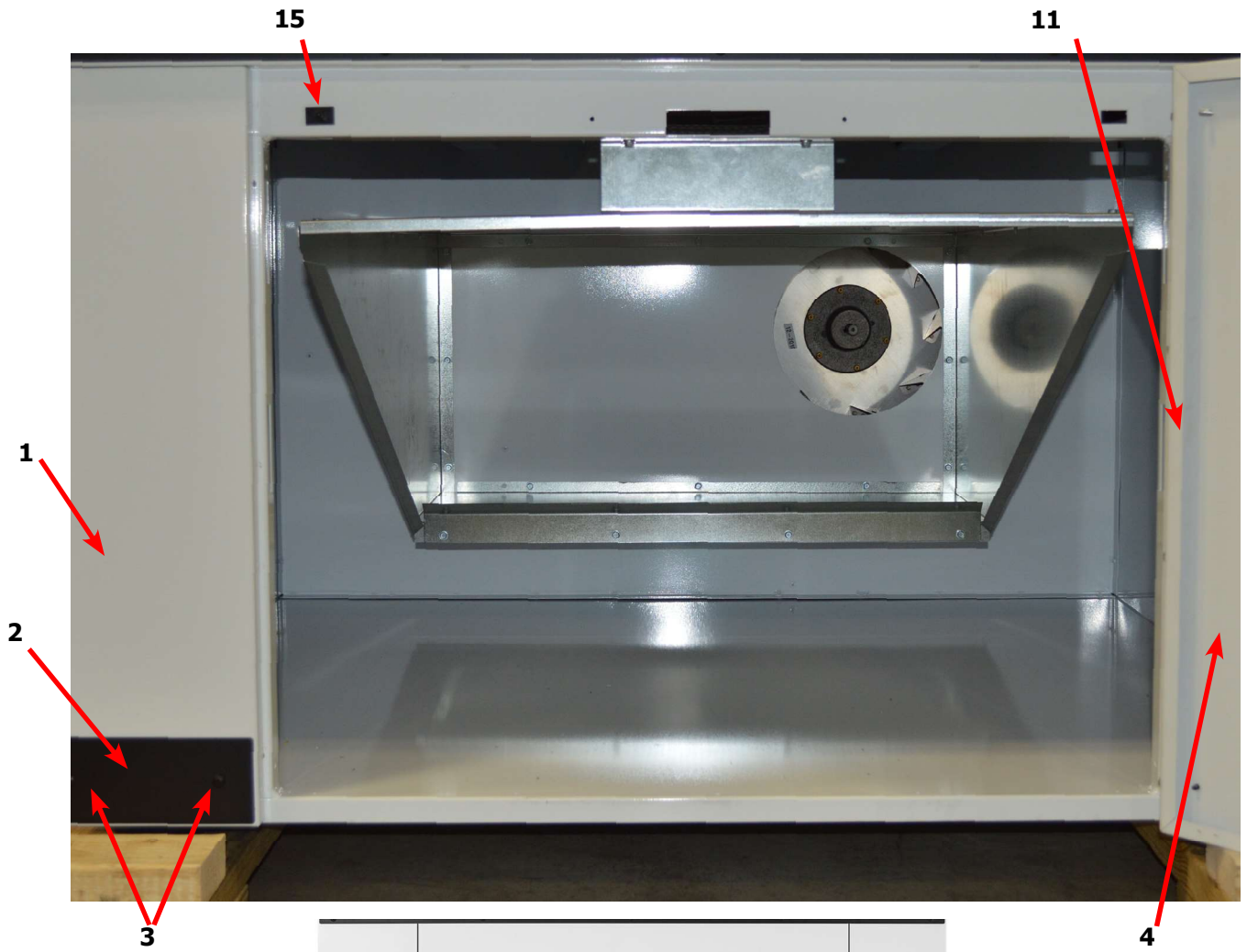

# Dryer Cabinet Group Continued

Key	Description	T-170	QTY
1	Panel Assy.-Upper Right	9989-691-003	1
*	Screw, #10ABx1/2	9545-008-024	2
2	Insulation-Right Upper, Burner Area	9277-059-001	1
3	Panel Assy.-Upper Left	9989-691-004	1
*	Screw, #10ABx1/2	9545-008-024	2
4	Insulation Tumbler Area, Right (Front & Back)	9277-051-005	2
4	Insulation Tumbler Area, Right (Center)	9277-051-006	1
5	Insulation Tumbler Area, Left (Front & Back)	9277-051-005	2
5	Insulation Tumbler Area, Left (Center)	9277-051-006	1
*	Switch-Door Closure (Square)	9539-501-001	2
*	Screen Assy, Lint	9822-034-001	1
*	Lint Hood Assembly	9834-013-001	1
7	Lint Hood, Top	9240-050-001	1
*	Lint Hood, Left Hand Side	9240-051-001	1
*	Lint Hood, Right Hand Side	9240-051-002	1
8	Lint Hood, Bottom	9058-031-001	1
9	Lint Hood, Angle	9003-377-001	1
10	Screw,- 10ABx3/8	9545-008-024	21
11	Hinge-Door, Lower	9243-084-002	1
*	Screw-10ABx3/8	9545-008-024	5
12	Impeller, w/set screws	9278-046-001	1
13	Harness -Temp Probe	9627-917-002	1
14	Wire Nut, #71B	8640-276-005	2
15	Temp Probe	9501-004-004	1
16	Screw-Phillips, 8Bx1/4	9545-045-005	1
17	Bracket, Temp Probe	9029-111-001	1
18	Screw, 8AB x 3/8	9545-045-008	2
19	Trim-Edge, Lint Hood	9578-092-003	2

## 120Lb. Temp Probe

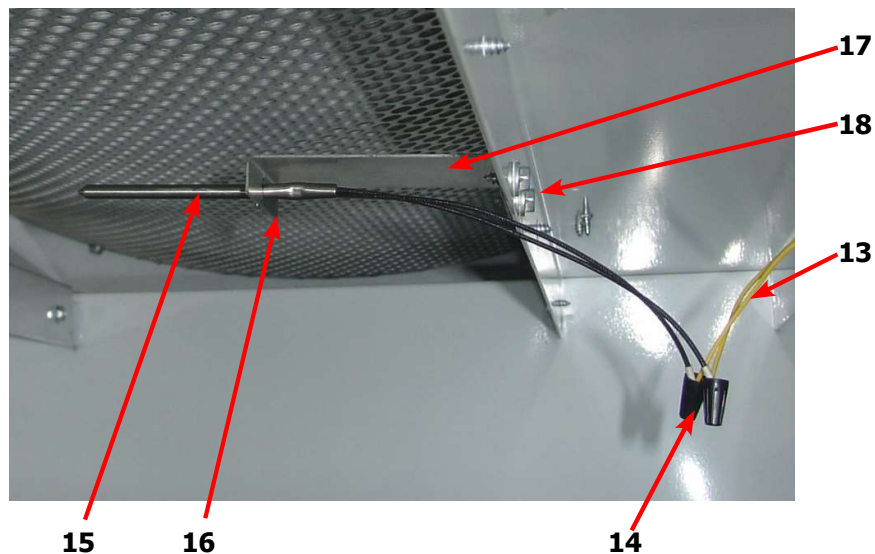



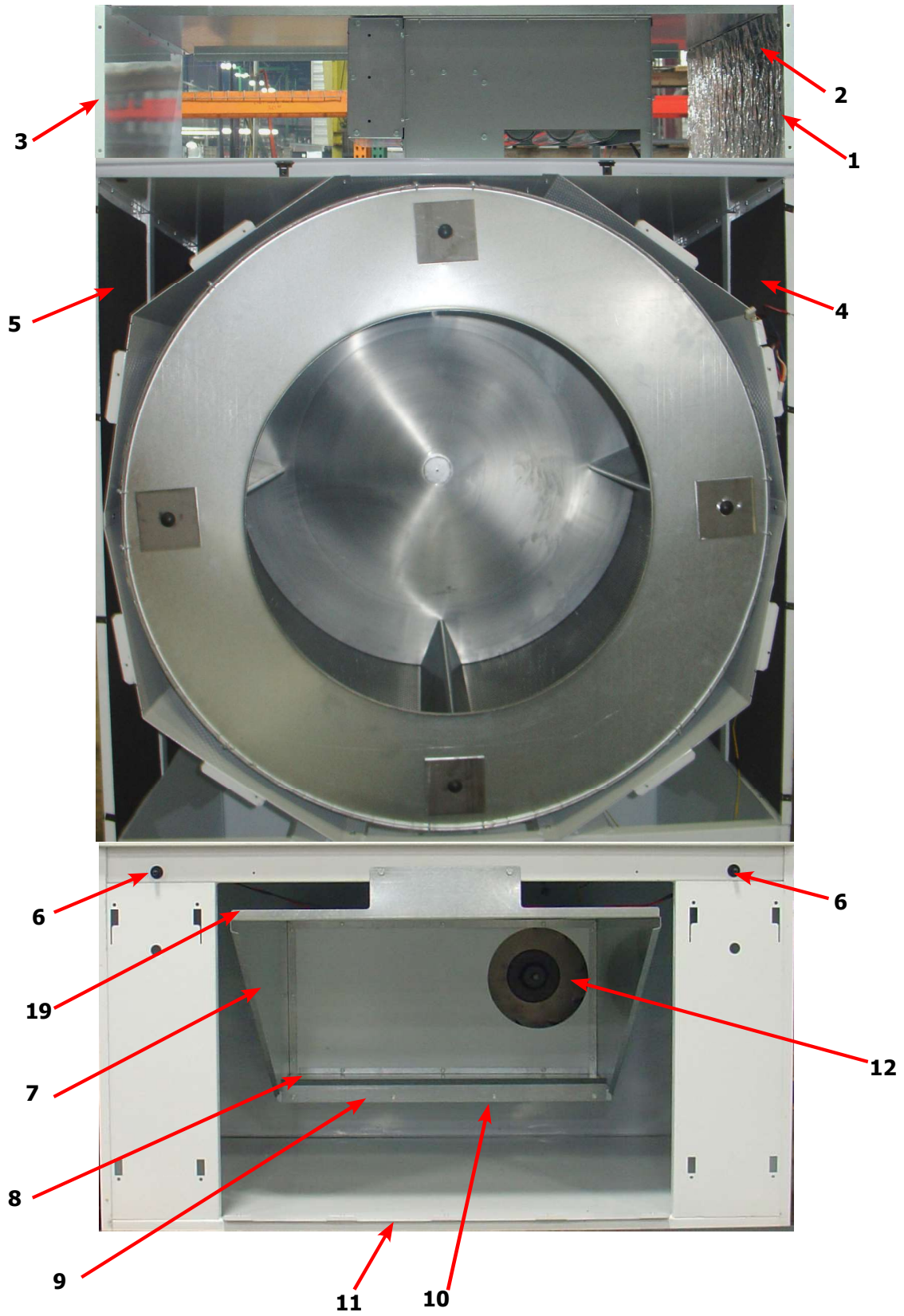

# Dryer Rear View 170Lb Reversing

Key	Description	T-170	QTY
1	Pulley, Driven	9453-173-004	1
2	Tolerance Ring	9487-234-004	1
3	Washer -Flat	8641-581-032	1
4	LockWasher - IntTooth, 1"	8641-582-018	1
5	Screw, 5/8-11 x 1 1/2	9545-060-001	1
6	Belt-Driven	9040-082-001	2
*	Impeller, 5" x 16"	9278-046-001	1
7	Plate Assembly-Impeller	9982-399-002	1
8	Nut-Wiz Lock, 5/16-18	8640-400-003	6
*	Gasket-Impeller Housing	9206-428-002	1
9	Motor-Blower	9376-337-001	1
*	Screw, 5/16-18 x 5/8	9545-014-004	4
*	Nut-Wiz Lock, 5/16-18	8640-400-003	4
12	Thermostat-Overtemp	9576-207-006	1
*	Screw-10AB x 3/8	9545-008-006	2
14	Pulley, Intermediate, w/Bearings	9908-055-001	1
*	Bearings	9036-159-011	2
*	Spacer-Bearings	9538-186-001	1
*	Ring-Retaining, Internal	9487-238-006	1
15	Washer-Flat	8641-581-039	1
16	Nut, 5/8-11	8640-425-002	1
17	Belt, Motor	9040-076-008	1
18	Motor, Drive	9376-319-001	1
19	Pulley-Motor	9453-191-001	1
20	Bushing, Motor -Support	9053-074-002	2
21	Rod-Motor Mounting, Black	9497-222-008	1
22	Collar-Shaft, w/Set Screws	9076-052-002	1
23	Chain-Belt tension	9099-012-004	1
*	Hook-S Type	9248-022-002	1
24	Spring, Belt Tension	9534-151-000	1

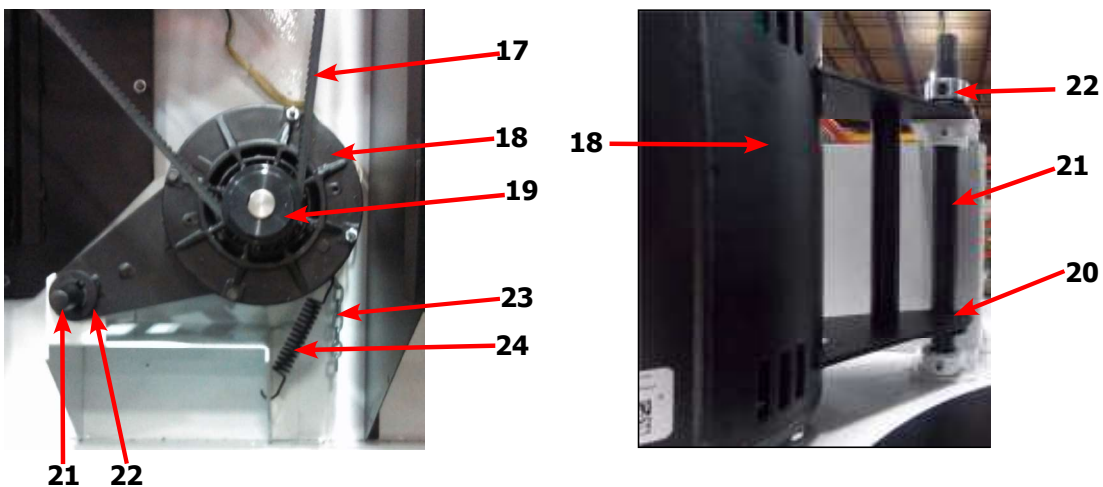

# Dryer Rear View 170Lb Reversing

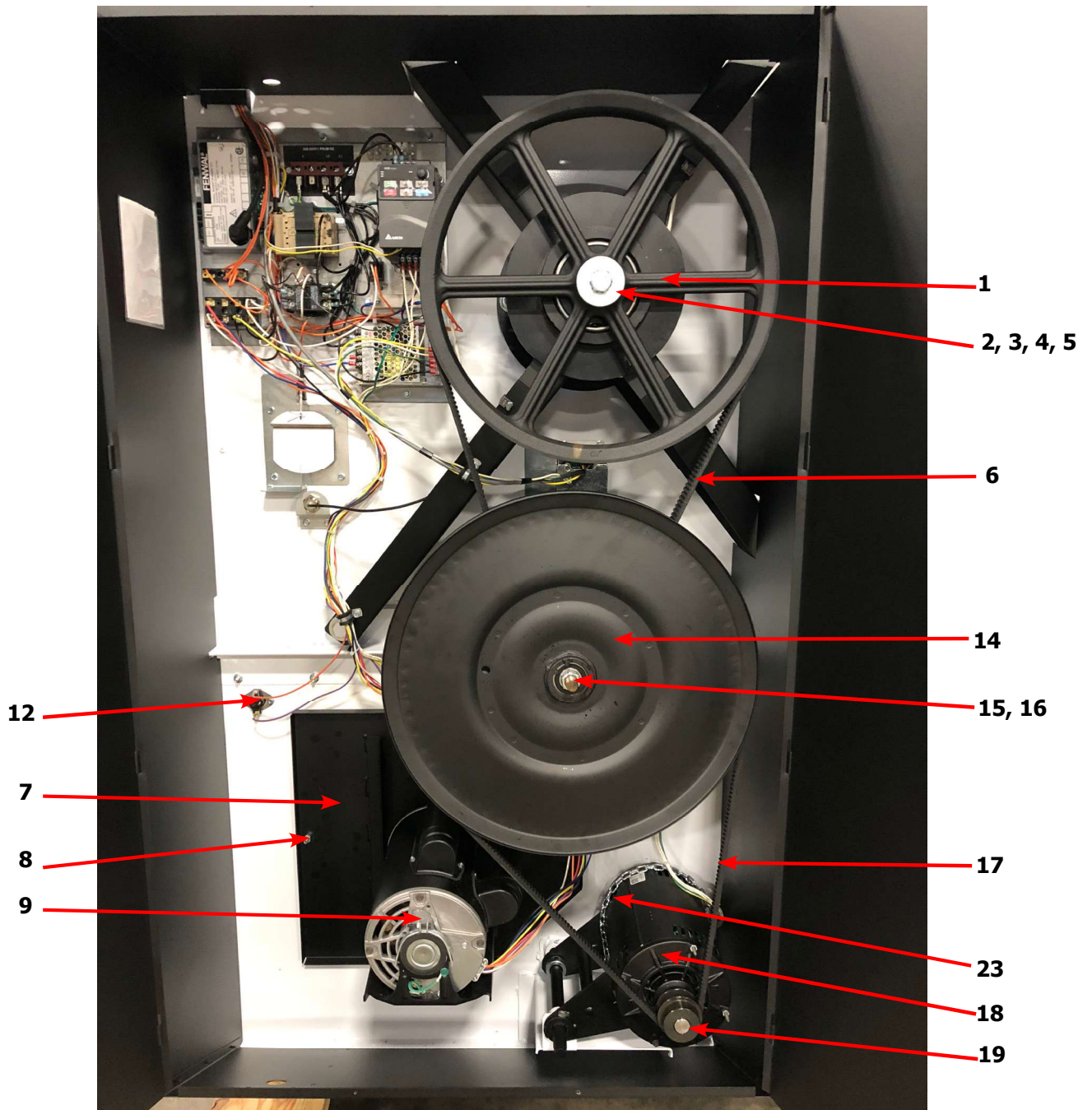

# Dryer Rear View 170Lb Reversing Continued

Key	Description	T-170	QTY
6	Plate Assembly-Intermediate, Tension	9982-378-002	1
7	Rod-Intermediate, Pivot	9497-230-002	1
8	Collar, Locking	9076-060-001	1
9	Bolt, 1/2-13 x 1 1/2	9545-017-001	2
10	Thermostat-Overtemp	9576-207-006	1
11	Screw-10AB x 3/8	9545-008-006	2
*	Impeller, 5" x 16"	9278-046-001	1
12	Plate Assembly-Impeller	9982-399-002	1
13	Nut-Wiz Lock, 5/16-18	8640-400-003	6
*	Gasket-Impeller Housing	9206-428-002	1
14	Motor-Blower	9376-337-001	1
15	Screw, 5/16-18 x 5/8	9545-014-004	4
16	Nut-Wiz Lock, 5/16-18	8640-400-003	4
17	Motor, Drive	9376-319-001	1
18	Pulley-Motor	9453-191-001	1
*	Bushing, Motor -Support	9053-074-002	2
19	Rod-Motor Mounting, Black	9497-222-008	1
20	Collar-Shaft, w/Set Screws	9076-052-002	1
21	Chain-Belt tension	9099-012-004	1
*	Hook-S Type	9248-022-002	1
*	Spring, Belt Tension	9534-151-000	1



7 8 6

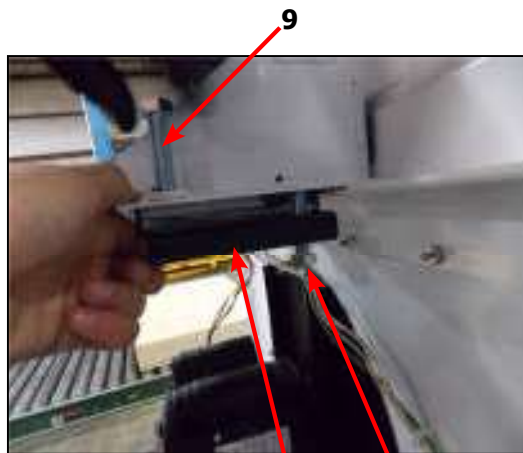

9 6 9



# Dryer Rear View 170Lb Reversing Continued

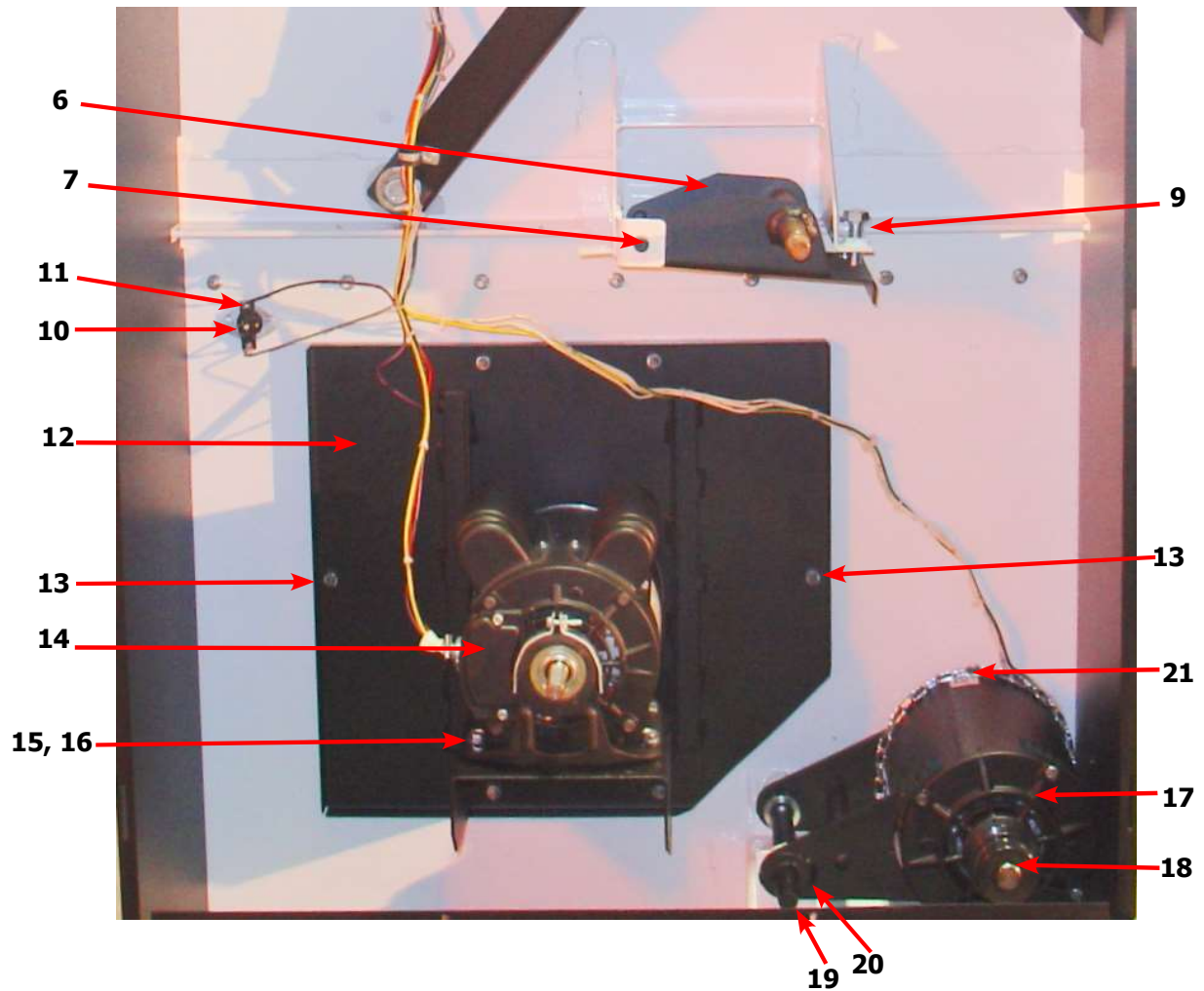

# Dryer Rear View-Guard & Exhaust

Key	Description	T-170	QTY
1	Cover Cabinet	9074-	1
*	Screw-5/16, 10ABx3/8	9545-008-024	16
*	Screws-10-16 x 1/2	9545-008-003	3
*	Guard-Side, Right	9208-156-002	1
*	Screw-Torx T20, 10B x 3/8, BLK	9545-008-034	7
3	Guard-Side, Left	9208-157-002	1
*	Screw-Torx T20, 10B x 3/8, BLK	9545-008-034	8
4	Guard-Top	9208-155-002	1
*	Screw-Torx T20, 10B x 3/8, BLK	9545-008-034	11
5	Guard-Bottom	9208-158-002	1
*	Screw-Torx T20, 10B x 3/8, BLK	9545-008-034	6
6	Guard-Wires	9208-115-002	1
*	Screw-Torx T20, 10B x 3/8, BLK	9545-008-034	2
7	Guard-Door, Right	9208-159-004	1
*	Screw-Torx T20, 10B x 3/8, BLK	9545-008-034	6
8	Guard-Door, Left	9208-159-003	1
9	Screw-Torx T20, 10B x 3/8, BLK	9545-008-034	4
*	Nut-Spring, U-type	8640-399-001	4
*	Booklet-Owners	8514-291-001	1
10	Diagram	9507-051-001	
11	Label-Warning & Notice	8502-763-001	1
12	Label-Instructions	8502-645-001	1
13	Decal-Lighting & Clearance	8527-151-001	1
14	Label-High Voltage	8502-614-004	1



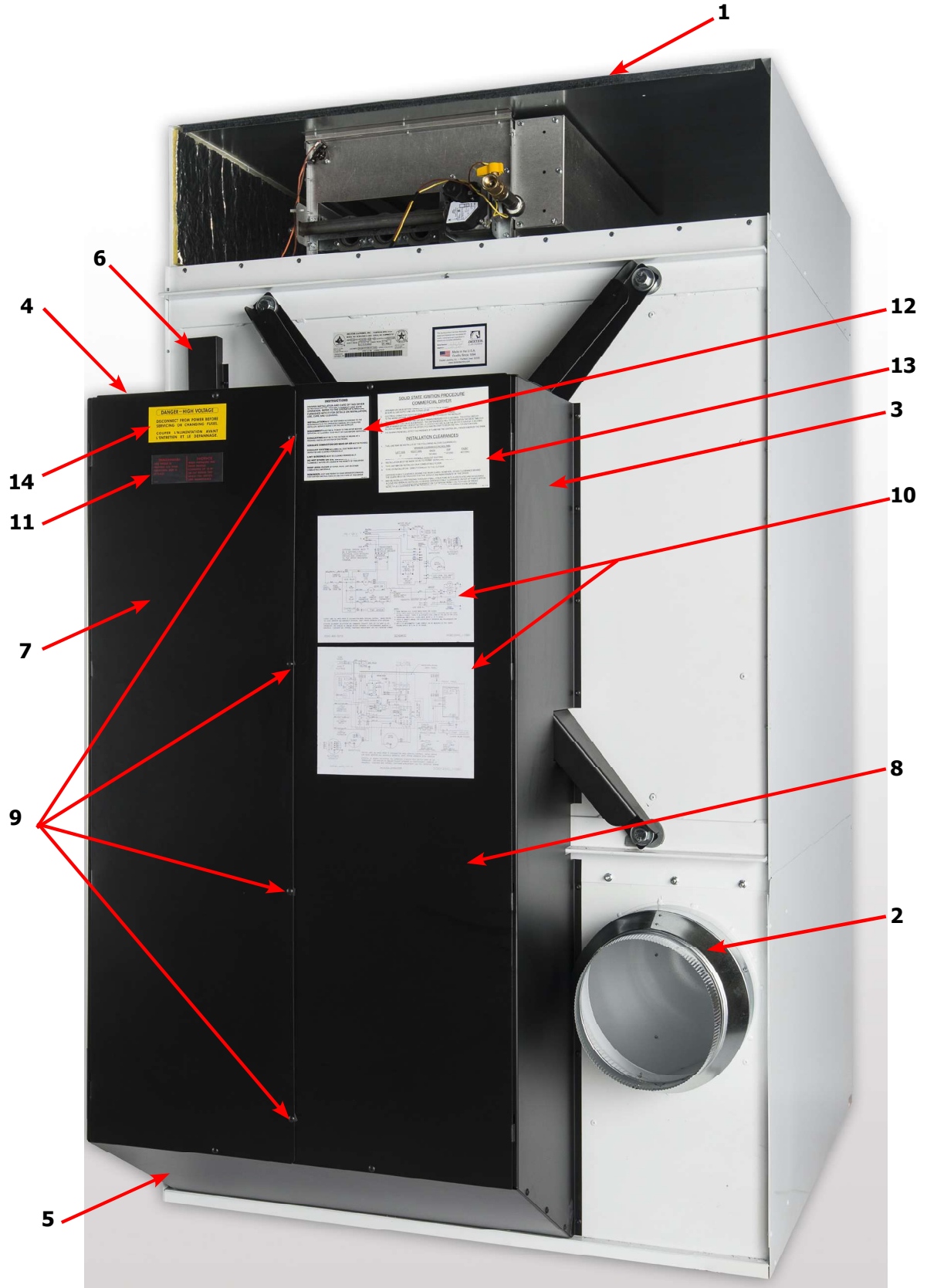

# Dryer Rear View-Bearing Housing 170Lb

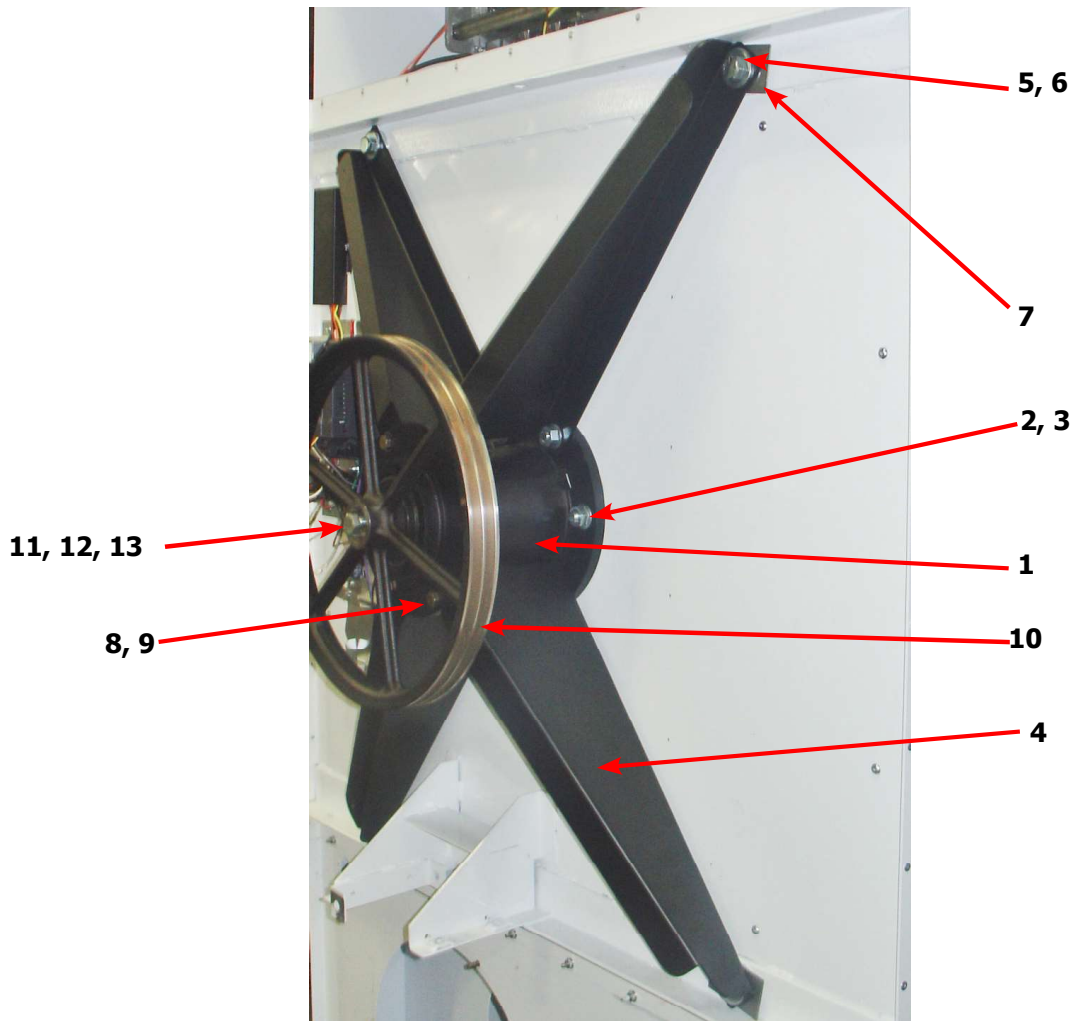

Key	Description	T-170	QTY
	Bearing Housing Complete Assy (Includes bearings & Spacer)	9803-231-001	1
1	Housing, Bearing	9241-208-002	1
*	Ring, Retaining-Internal	9487-238-004	1
*	Bearing, Ball, Front	9036-159-006	1
*	Spacer, Bearing	9538-190-001	1
*	Bearing, Ball, Rear	9036-159-005	1
*	Washer, Flat	8641-581-040	6
2	Screw-5/8"-11 x 1 1/2"	9545-060-001	6
3	Nut-Whizlock, 5/8" x 11	8640-425-001	6
4	Arm-Support Housing	9001-068-002	4
5	Screw-5/8-11 x 1 1/2	9545-060-001	4
6	Washer, Flat 5/8"	8641-581-038	4
7	Shim	9552-045-001	AR
8	Screw-7/16"-14 x 1 1/2"	9545-059-003	4
9	Nut-Whizlock, 7/16"	8640-416-005	4
*	Tolerance Ring	9487-234-004	1
10	Pulley Driven	9453-173-004	1
11	Washer, Flat 5/8" x 2 1/4"	8641-581-032	1
12	Lock Washer Spring, 1/2	8641-582-018	1
13	Screw, 5/8-11 x 1 1/2"	9545-060-001	1

# Dryer Tumbler Group 170Lb

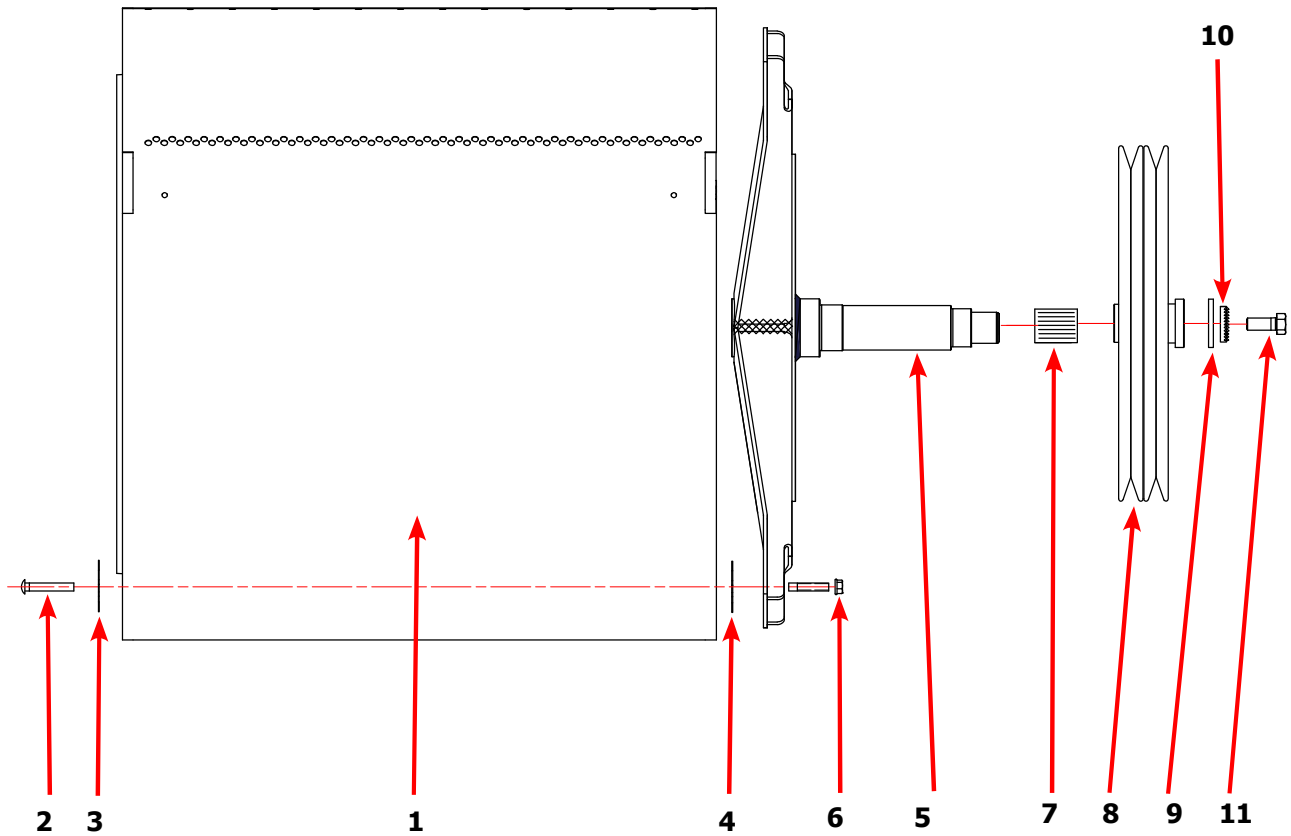

Key	Description	T-170	QTY
*	Tumbler Assy Complete W/Spider (GALV)	9848-162-002	1
1	Tumbler Assy (Galvanized)	9848-161-002	1
2	Rod, Tumbler	9497-226-004	4
3	Plate support, Tie Rod	9452-805-001	4
4	Shim	9552-013-003	AR
5	Spider Assy	9568-020-001	1
6	Nut, Wiz Lock	8640-417-005	4
7	Tolerance Ring	9487-234-004	1
8	Pulley, Driven	9453-173-004	1
9	Washer -Flat	8641-581-032	1
10	LockWasher - IntTooth, 1''	8641-582-018	1
11	Screw, 5/8-11 x 1 1/2	9545-060-001	1

## Dryer Burner Housing Group 170Lb

Key	Description	T-170	QTY
*	Housing Assembly, Burner	9803-232-001	1
1	Screw, 10ABx3/8	9545-008-024	55
2	Bracket-Support, Gas Valve	9029-329-001	1
3	Side-Extention Baffle, Burner Housing	9551-076-001	2
4	Burner, Main	9048-022-001	3
5	Baffle-Burner Housing, Extension	9049-128-001	1
6	Panel-Burner Housing, Front	9444-026-001	1
7	Panel-Burner Housing, Back	9444-025-001	1
8	Panel-Burner Housing, Side Left	9551-075-001	1
9	Baffle-Center, Burner	9049-127-001	1
10	Panel-Burner Housing, Side Right	9551-077-001	1
11	Channel-Burner Housing, Right	9081-199-001	1
12	Bracket-Manifold	9029-328-001	1
13	Bracket-Support, Burner, Front	9029-330-001	1
14	Bracket-Support, Burner, Rear	9029-331-001	1
15	Control Assy,Gas Valve	9857-193-001	1
16	Manifold Assy	9381-016-001	1
17	Top Assembly, Burner Housing	9961-162-001	1
18	Screw, 10Bx1/4	9545-008-001	18
*	Orfice-Natural, #13	9425-069-028	3
*	Orfice-LP, #34	9425-069-029	3
*	Kit, LP Conversion	9732-102-052	1
19	Thermostat-HI-Limit	9576-203-002	1
20	Electrode-Ignition	9875-002-003	1
21	Bracket-Igniter	9029-243-001	1
22	Elbow-1" Street, Black	8615-104-046	1

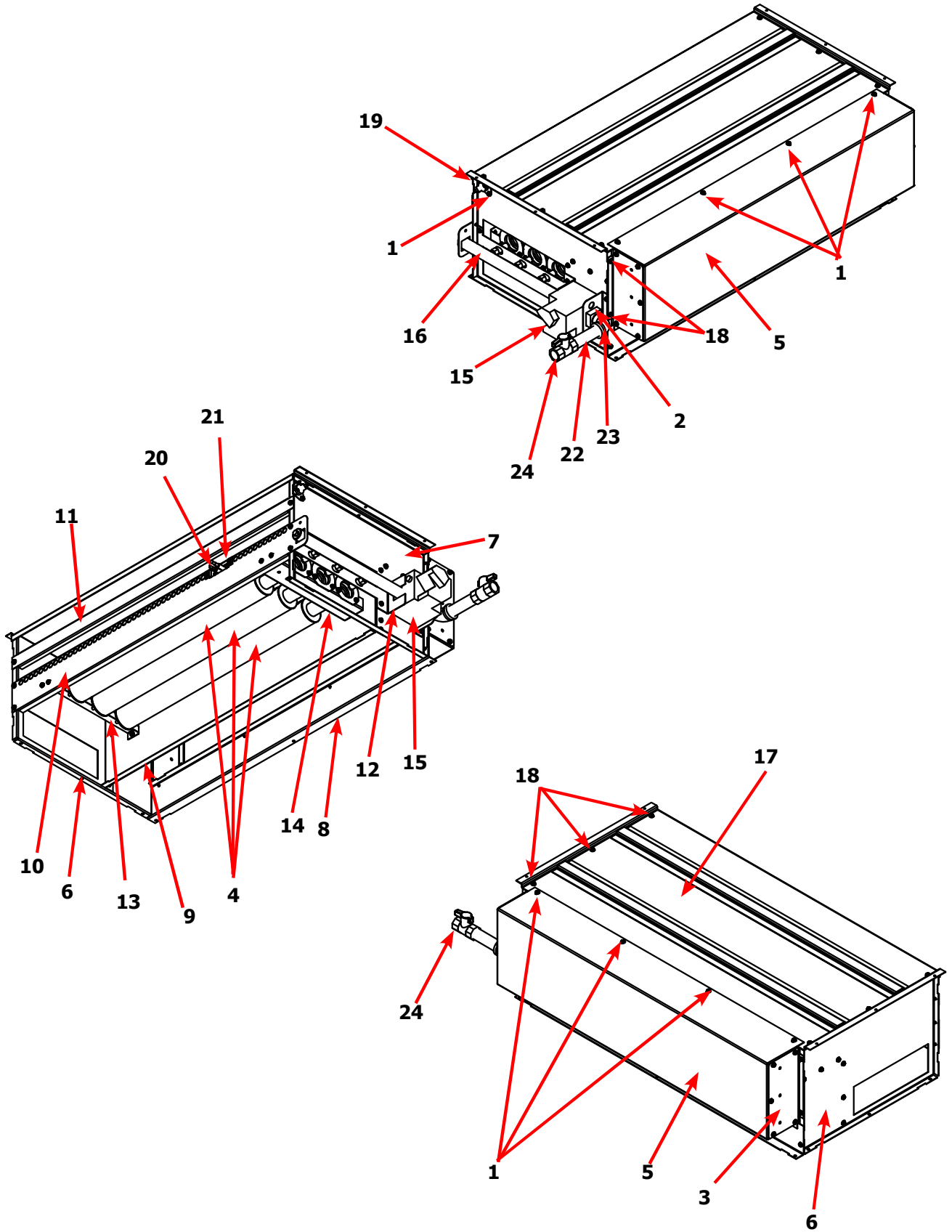

# Dryer Air Flow Switch Assembly

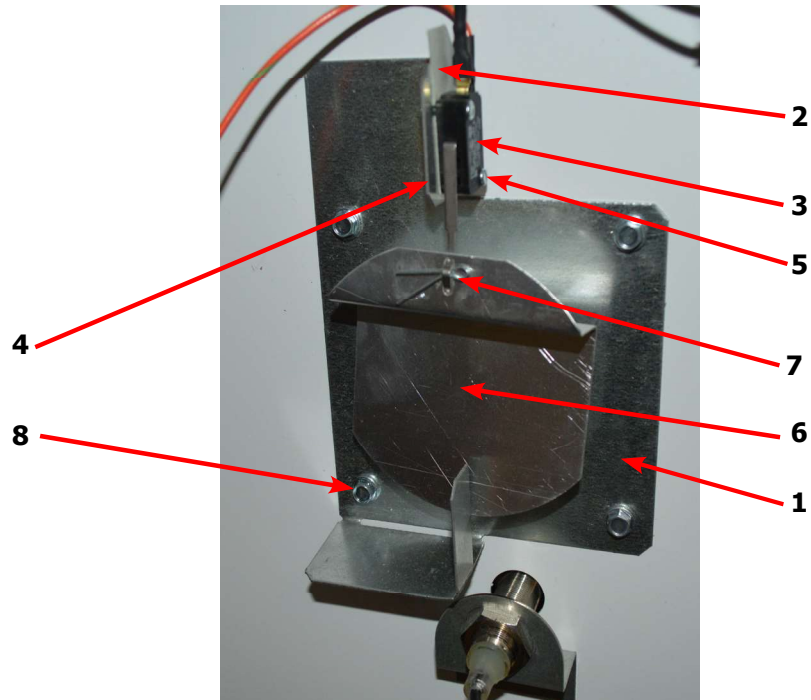

Key	Description	T-120	QTY
*	Air Flow switch Assy	9801-098-001	1
1	Bracket-Airflow switch	9029-200-001	1
2	Shield-Switch	9550-169-003	1
3	Switch-Micro	9539-461-009	1
4	Nut-Twin, 4-40	8640-401-001	1
5	Screw-.625, 4-40	9545-020-001	2
6	Actuator-Air Flow Switch	9008-007-001	1
7	Pin-Cotter, .09375x.75	9451-169-002	1
8	Screw, 10ABx3/8	9545-008-024	4





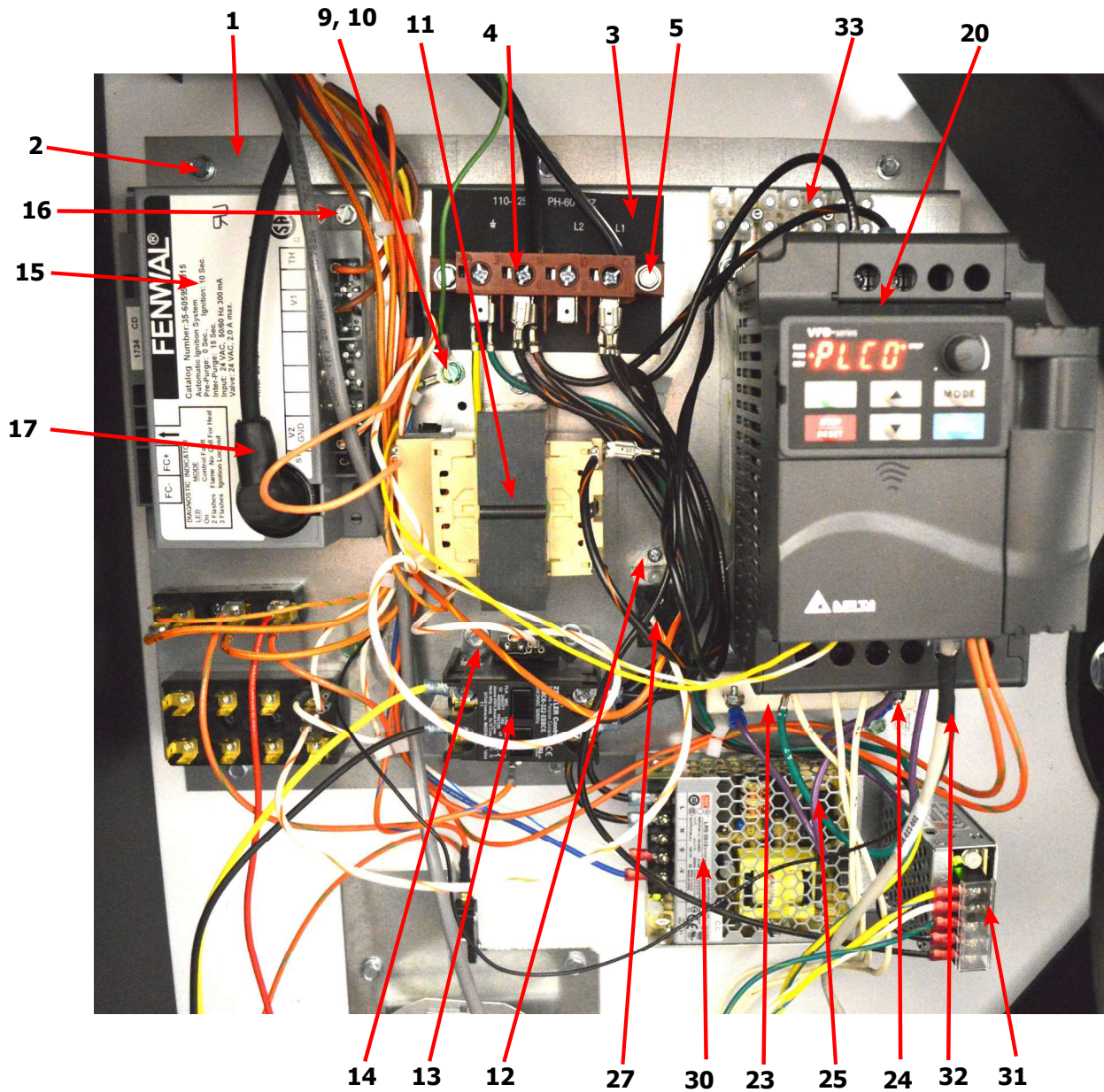

# Dryer Rear View-Control Box

Key	Description	T-170	QTY
*	Control Assembly, (1 thru 28)	9857-270-001	
1	Channel-Controls	9081-191-001	1
2	Screw, 5/16-10B-3/8	9545-008-026	6
3	Strip-Marker, Terminal	9558-029-006	1
4	Terminal Block Assy-Power, 4Pole	9897-035-001	1
5	Screw, 5/16-10AB-3/8	9545-008-024	2
11	Transformer, Control	8711-007-002	1
12	Screw, 5/16-10AB-3/8	9545-008-024	2
13	Relay-Motor, 30Amp, 24VAC	5192-295-011	1
14	Screw, 5/16-10AB-3/8	9545-008-024	2
15	Control Assy, Ignition (Module)	9857-182-001	1
16	Screw-8Bx3/4"	9545-045-007	2
*	Harness, Ignition Module	9627-867-013	1
17	Wire Assy- High Voltage Lead	9631-403-005	1
20	Drive-VD Inverter, 1HP, 208-240VAC	9375-032-021	1
PS	Key Pad, Delta E-Drive	9150-044-001	1
21	Screw-#10B x 1/2	9545-008-026	4
22	Wire Assy-Green, 18"	8220-092-006	1
23	Resistor-Dynamic Breaking, 200OHM	9483-004-002	1
24	Screw-5/16, 10ABx3/8	9545-008-024	2
25	Wire Assy, Violet 24"	8220-118-003	2
27	Relay, 24VAC	5192-285-004	1
28	Screw, 6B x 3/8	9545-031-003	4
*	Stand off	9527-007-001	7
30	Elecperiph - Power Supply, 12V	9150-054-001	1
*	Screw - pnhdcr, 6AB x 3/4	9150-054-001	2
31	Elecperiph - Power Supply, 24VDC	9150-057-001	1
*	Screw - pnhdcrsems, #4-40 x 3/16	9545-020-009	2
32	Data Cable	9806-023-002	1
33	Terminal Block	9897-039-001	1
*	Screw - pnhdcr, 6AB x 3/4	9545-031-010	2

# RMC Parts

Key	Description	T-170	QTY
1	Strip-sensing,moisture	9558-034-001	1
*	Rivet-blind,3/16steel	9491-009-001	6
2	Controlsassy-rotatingpcb,rmc	9857-248-001	1
*	Screw-hxwshrndrcuthd,10abx3/8	9545-008-024	2
3	Wiringharness-rmc,sensor,	9627-941-003	1
4	Conduit-rmcwires,	6068-055-001	1
*	Screw-hxwshrndrcuthd,10abx3/8	9545-008-024	2
5	Grommet-3/16id	9209-037-002	1
6	Screw-hxwshrds,10-32tx1/2grn	9545-008-027	1
*	Lockwasher-exttooth,#10	8641-582-006	1
7	Bracketassy-cabinet,RMC	9985-204-001	2
*	Screw-hxwshds,10bx1/4	9545-008-001	4
8	Controlsassy-stationarypcb,RMC	9857-247-001	1
*	Nut-hexkeps,#10-32unf,2b	8640-413-002	2
9	Wiringharn-RMC,can/pwr,	9627-940-003	1
10	Cover-service,RMC	9074-385-001	1
*	Screw-hxwshds,10bx1/4	9545-008-001	2

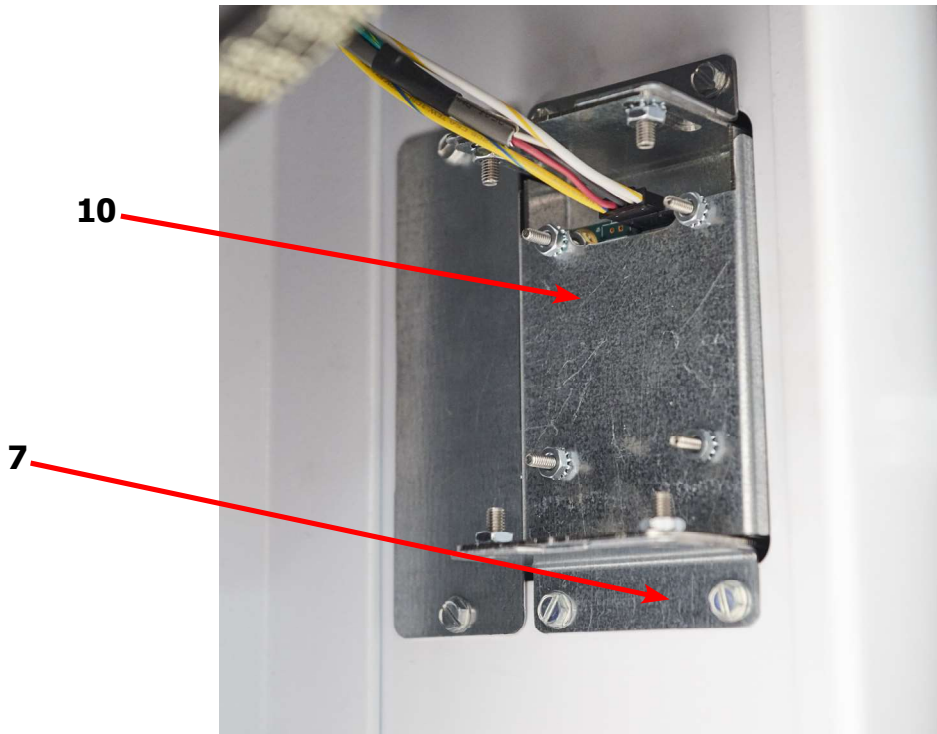



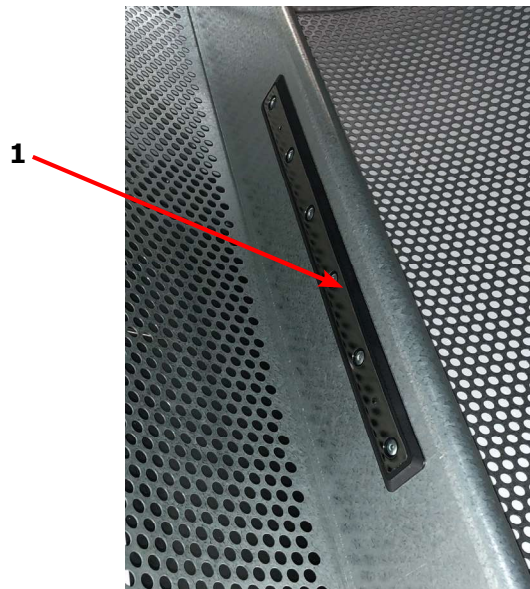
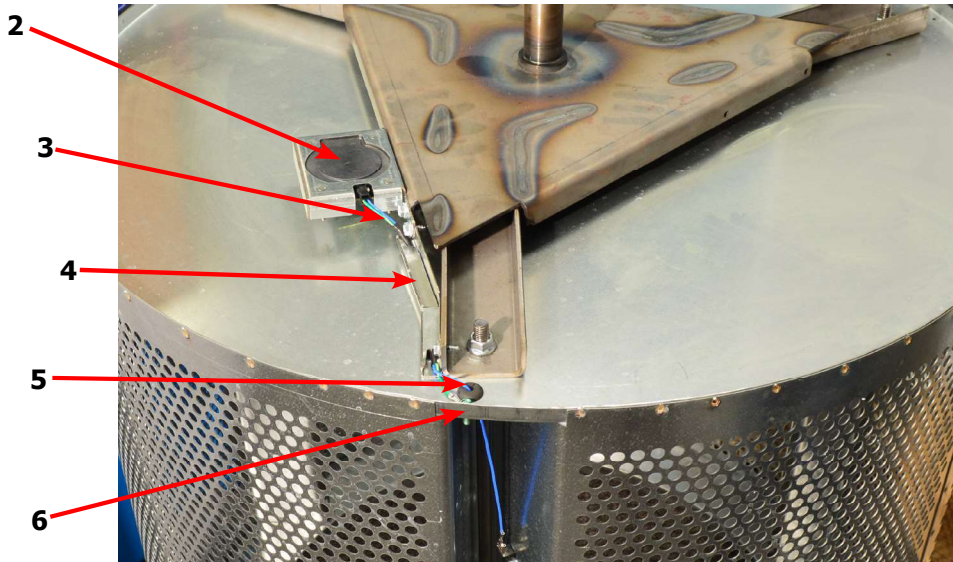
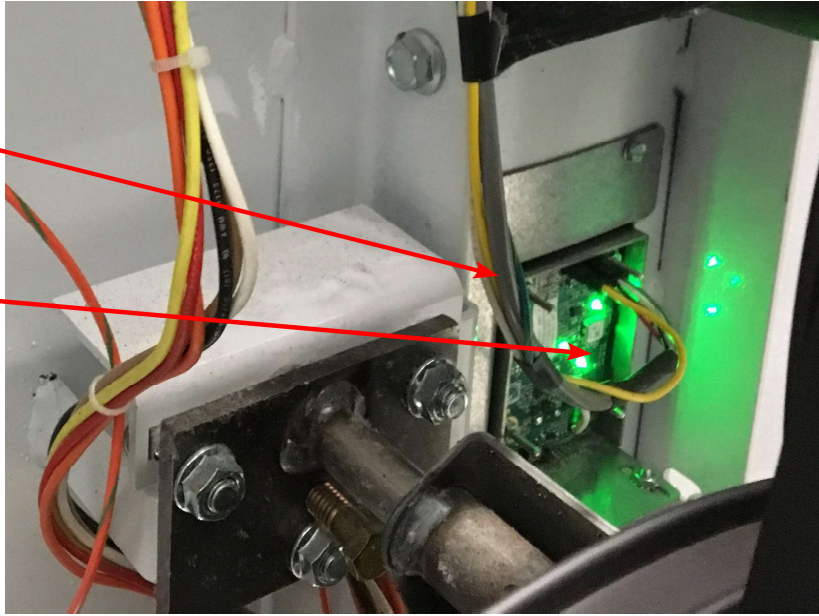

# Water Suppression Parts

Key	Description	T-170	QTY
*	FSS Kit	9732-358-005	1
1	Nozzleassy-firesuppression	9872-004-001	1
*	Screw-hxwshrundrcuthd,10abx3/8	9545-008-024	3
2	Tube-nozzle,inlet	9574-262-001	1
3	Bushing-support	9053-083-001	1
*	Screw-hxwshrundrcuthd,10abx3/8	9545-008-024	1
4	Fitting-adapt,3/8nptto1/2hose	8615-115-001	1
5	Valve-water,24v,epdm(nsf)	9379-183-013	1
6	Wireasy-jumper,org/brn,120-6	8220-161-003	1
7	Wireasy-jumper,wht/org,60"-6"	8220-090-019	1
8	Screw-hxwshrundrcuthd,#10bx1/2	9545-008-026	2
9	Hose-water,3"	9242-453-031	2
10	Fitting-y,1/2	8615-119-001	1
11	Hose-water,"	9242-453-034	1
*	Clamp-hose,worm,1in	8654-117-015	6
*	Clamp-cable	8654-061-001	2
*	Screw-hxwshrundrcuthd,10abx3/8	9545-008-024	2
12	Guard-water valve	9208-145-001	1
*	Screw-hxwshrundrcuthd,10abx3/8	9545-008-024	2
13	Thermostat-fss	9576-212-001	1
*	Screw-hxwshdslt,8bx1/2	9545-045-002	2
	Wireasy-jumper,org,77"	8220-162-002	1
14	Pcbassy-relay	9799-028-001	1
*	Screw-hxwshrundrcuthd, #10Bx1/2	9545-008-026	2
15	Wireasy-jumper,v2.0,relay pcb	8220-159-006	1
16	Wiringharness-cntrl/relay,v2.0	9627-921-001	1
17	Switch-momentary,n.o.	9539-500-001	1
*	Wireasy-org, 75"	8220-108-016	1
18	Wiringharness-relaypowerboard	9628-006-002	1
*	Wireasy-jumper,wht/org,5"	8220-161-002	1
*	Wireasy-org,11"	8220-108-014	1
19	Bracket-mtg,ohp sensor	9029-315-001	
*	Screw-hxwshrundrcuthd,10abx3/8	9545-008-024	



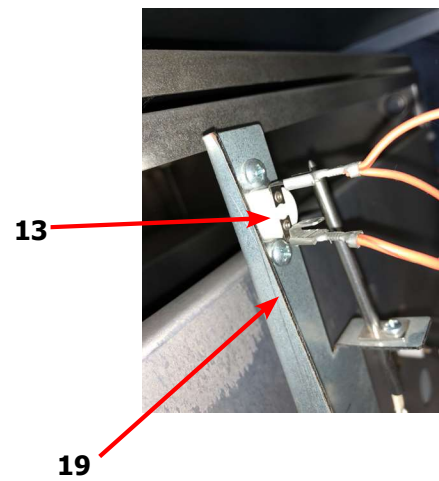
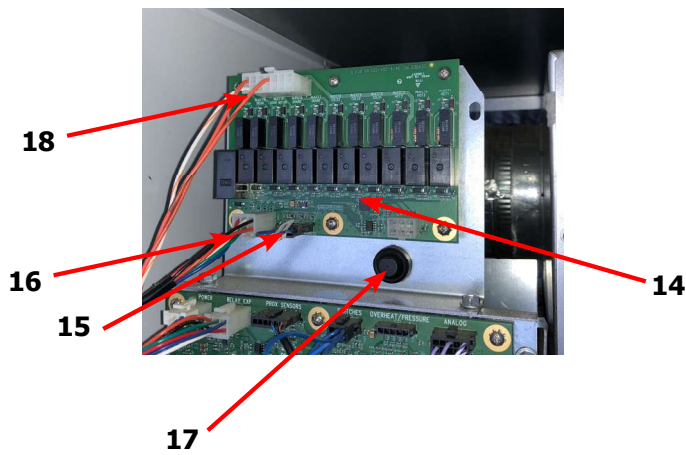
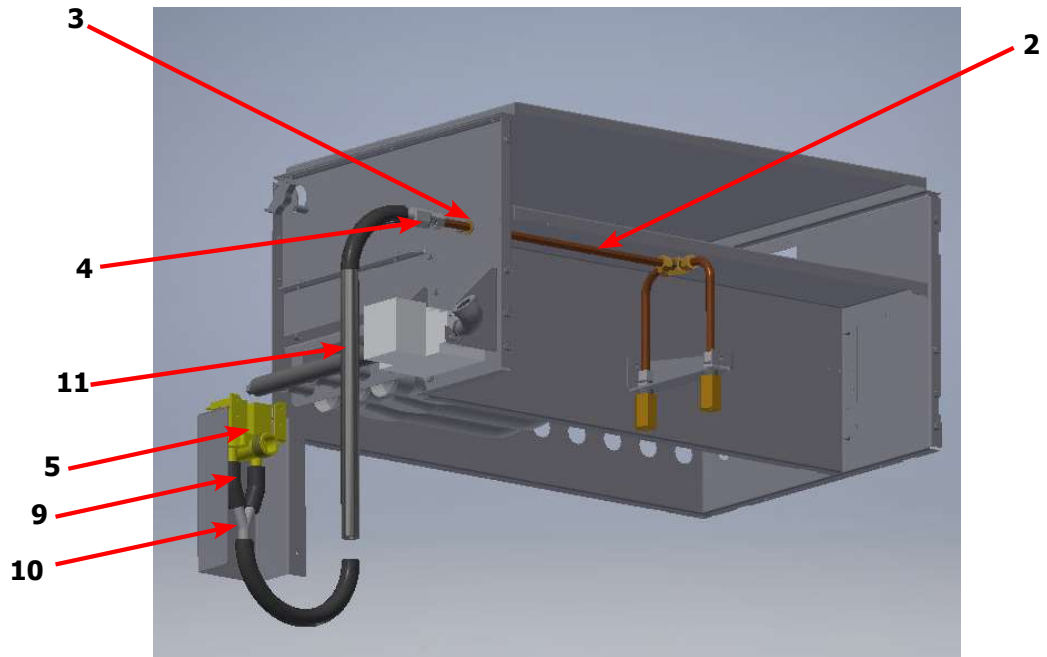
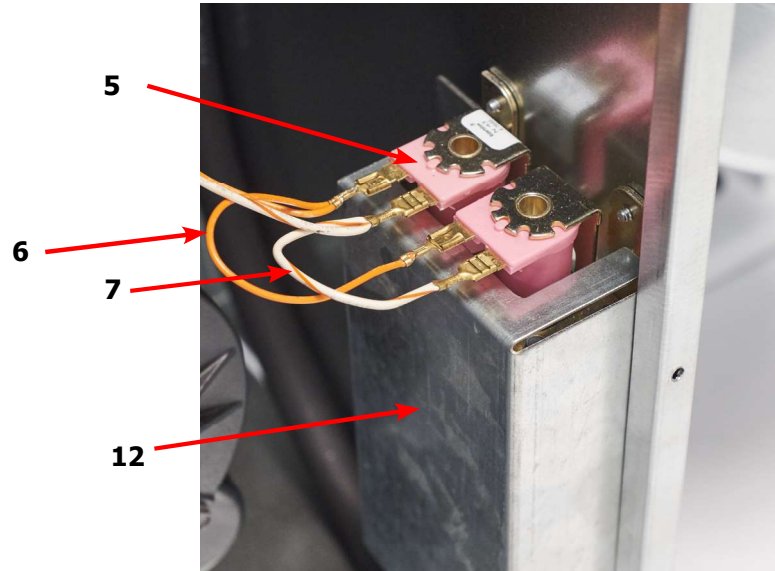

WIRING OF THE FSS SYSTEM USING THE SAME TRANSFORMER AND TERMINAL BLOCK FROM SHEET 1

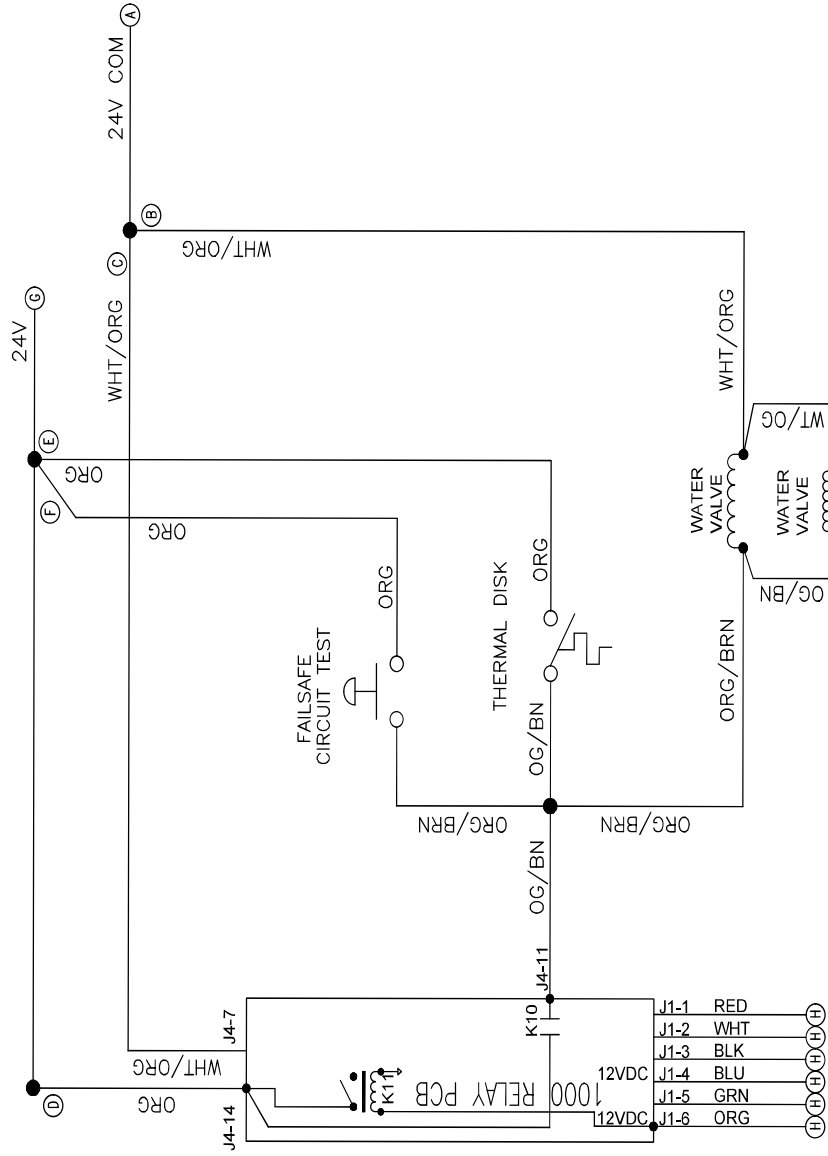

9508-050-001PR

SCHEMATIC

DN0170N\_-13\_O\_B--\_X

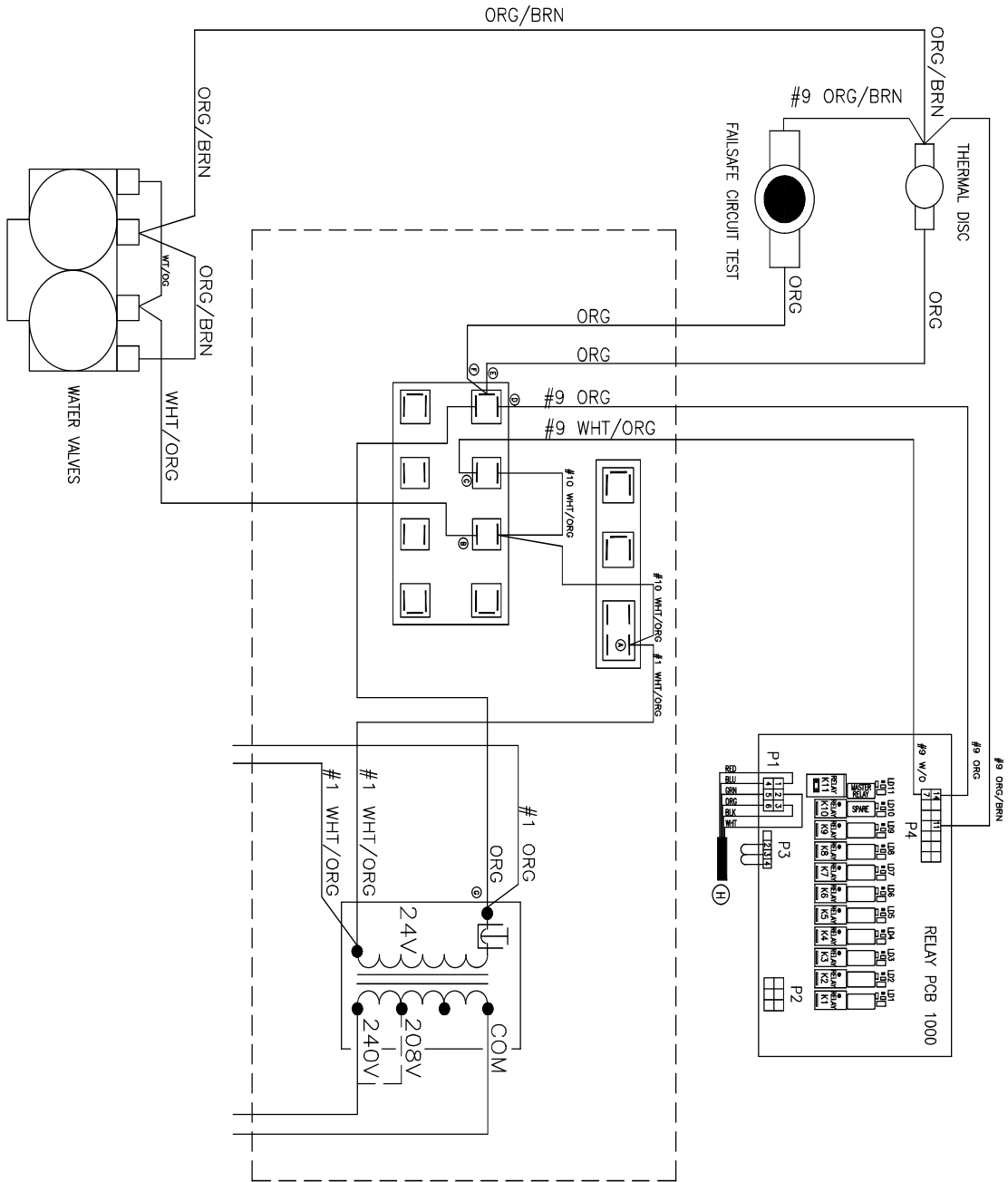

9507-050-001PR

WIRING DIAGRAM

DN0170N\_-13\_0\_B-\_\_\_\_\_-\_\_X

# Wiring Schematic

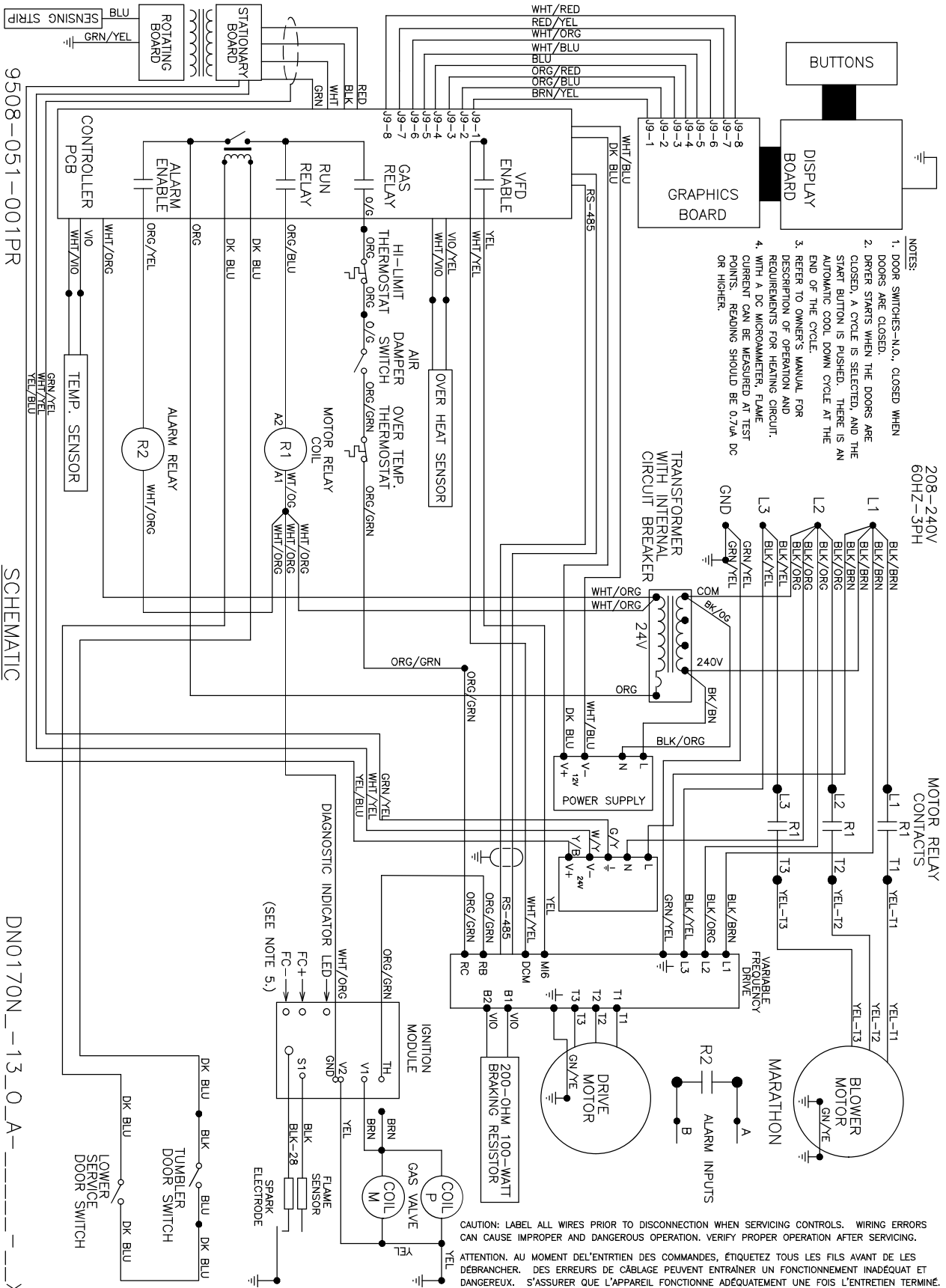

# Wiring Diagram

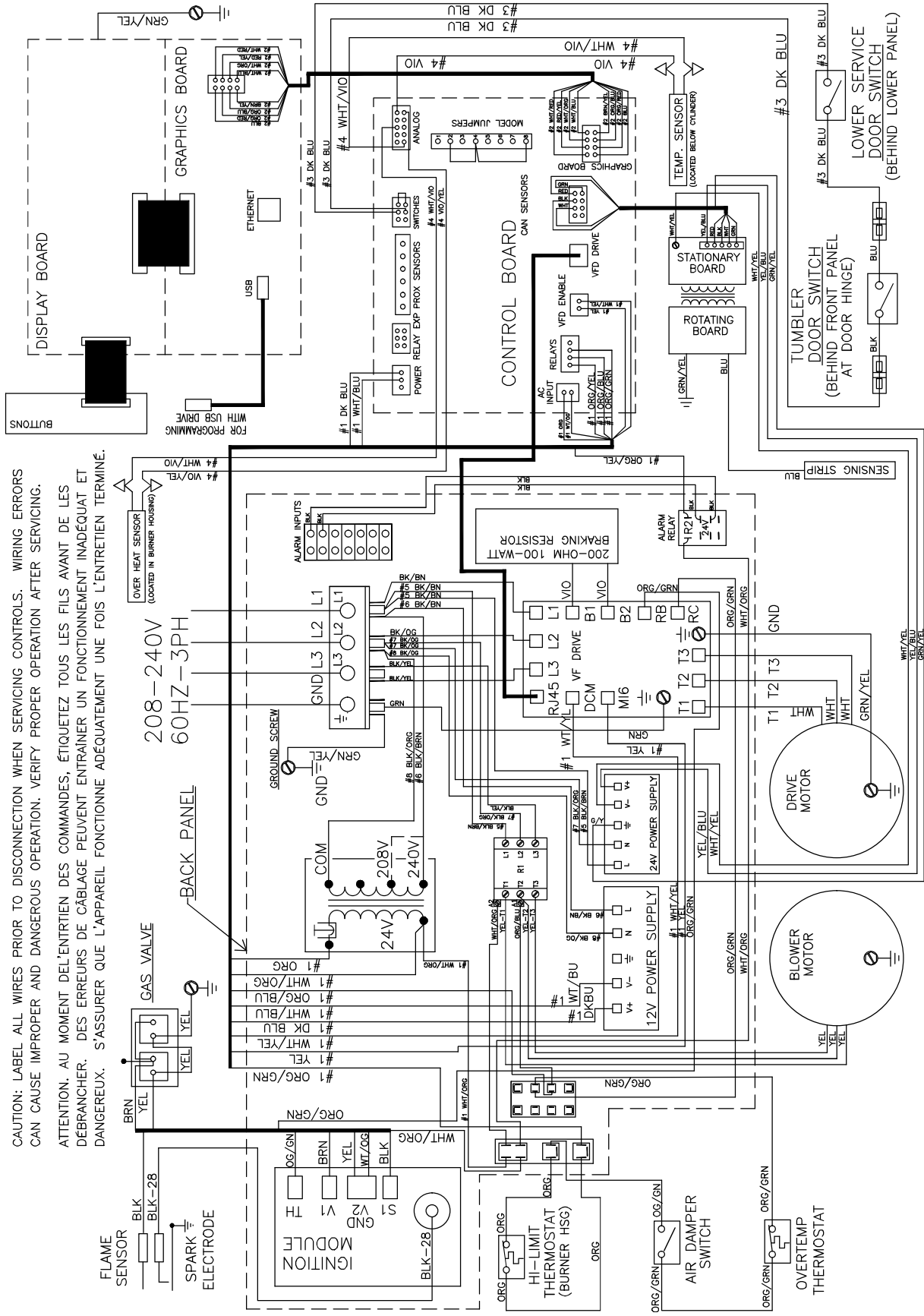

CAUTION: LABEL ALL WIRES PRIOR TO DISCONNECTION WHEN SERVICING CONTROLS. WIRING ERRORS CAN CAUSE IMPROPER AND DANGEROUS OPERATION. VERIFY PROPER OPERATION AFTER SERVICING.

ATTENTION: AU MOMENT DE L'ENTRIEN DES COMMANDES, ÉTIQUÉTEZ TOUS LES FILS AVANT DE LES DÉBRANCHER. DES ERREURS DE CÂBLAGE PEUVENT ENTRAÎNER UN FONCTIONNEMENT INADÉQUAT ET DANGEREUX. S'ASSUREZ QUE L'APPAREIL FONCTIONNE ADEQUATEMENT UNE FOIS L'ENTRIEN TERMINE.

9507-051-001PR WIRING DIAGRAM DN0170N\_13\_0\_A-X

# Wiring Schematic With FSS

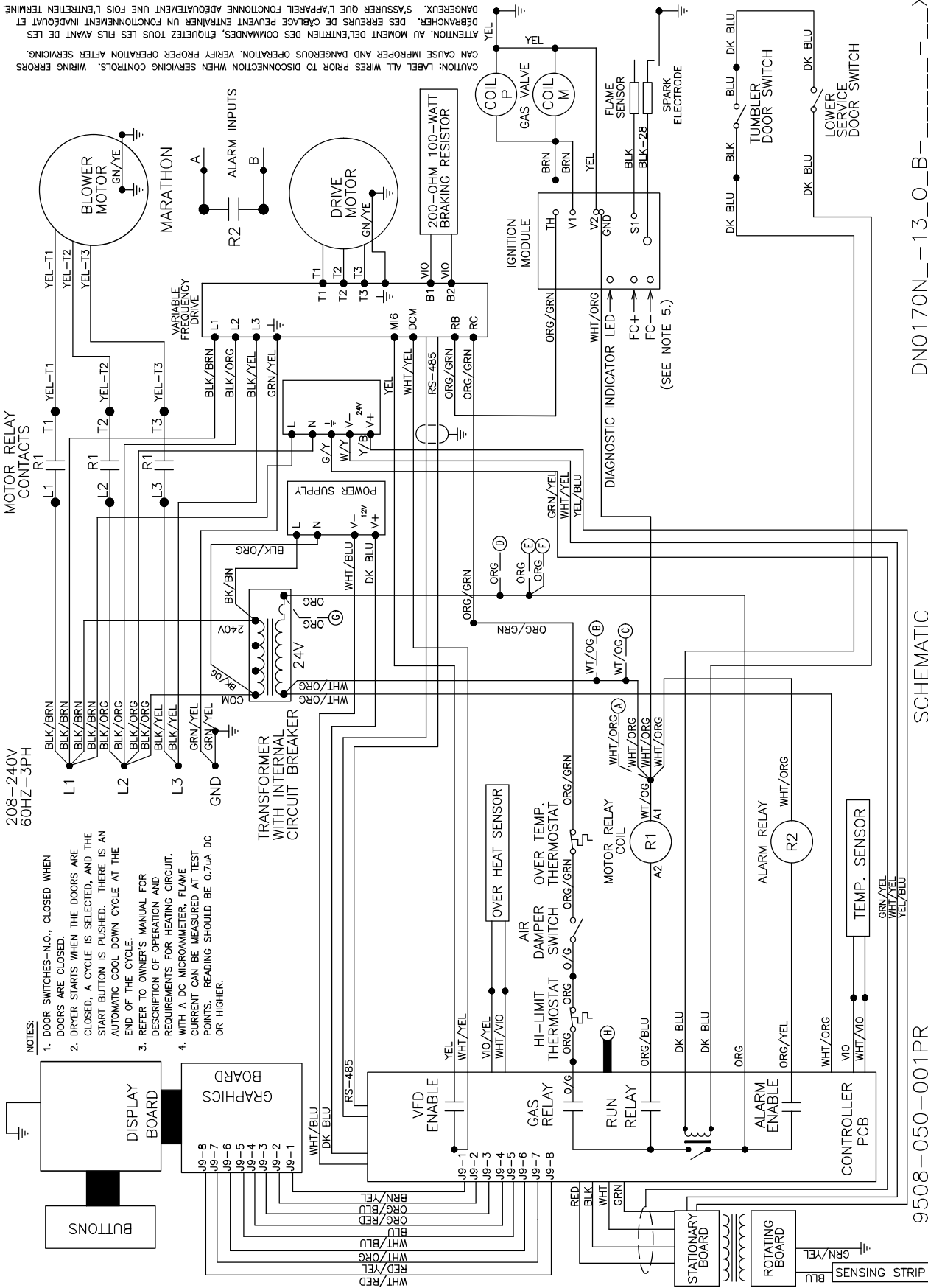

CAUTION: LABEL ALL WIRES PRIOR TO DISCONNECTION WHEN SERVICING CONTROLS. WIRING ERRORS CAN CAUSE IMPROPER AND DANGEROUS OPERATION. VERIFY PROPER OPERATION AFTER SERVICING.  
ATTENTION: AU MOMENT DEL'ENTRETIEN DES COMMANDES, ETIQUETEZ TOUS LES FILS AVANT DE LES DEBRANCHER. DES ERREURS DE CABLAGE PEUVENT ENTRAÎNER UN FONCTIONNEMENT INADÉQUAT ET DANGEREUX. S'ASSURER QUE L'APPAREIL FONCTIONNE ADEQUATEMENT UNE FOIS L'ENTRETIEN TERMINE.

- NOTES:**
- DOOR SWITCHES—N.O., CLOSED WHEN DOORS ARE CLOSED.
  - DRYER STARTS WHEN THE DOORS ARE CLOSED, A CYCLE IS SELECTED, AND THE START BUTTON IS PUSHED. THERE IS AN AUTOMATIC COOL DOWN CYCLE AT THE END OF THE CYCLE.
  - REFER TO OWNER'S MANUAL FOR REQUIREMENTS FOR HEATING CIRCUIT, DESCRIPTION OF OPERATION AND CURRENT CAN BE MEASURED AT TEST POINTS. READING SHOULD BE 0.70A DC OR HIGHER.

9508-050-001PR

SCHEMATIC

DN0170N\_-13\_O\_B\_-\_X



# Wiring Diagram With FSS

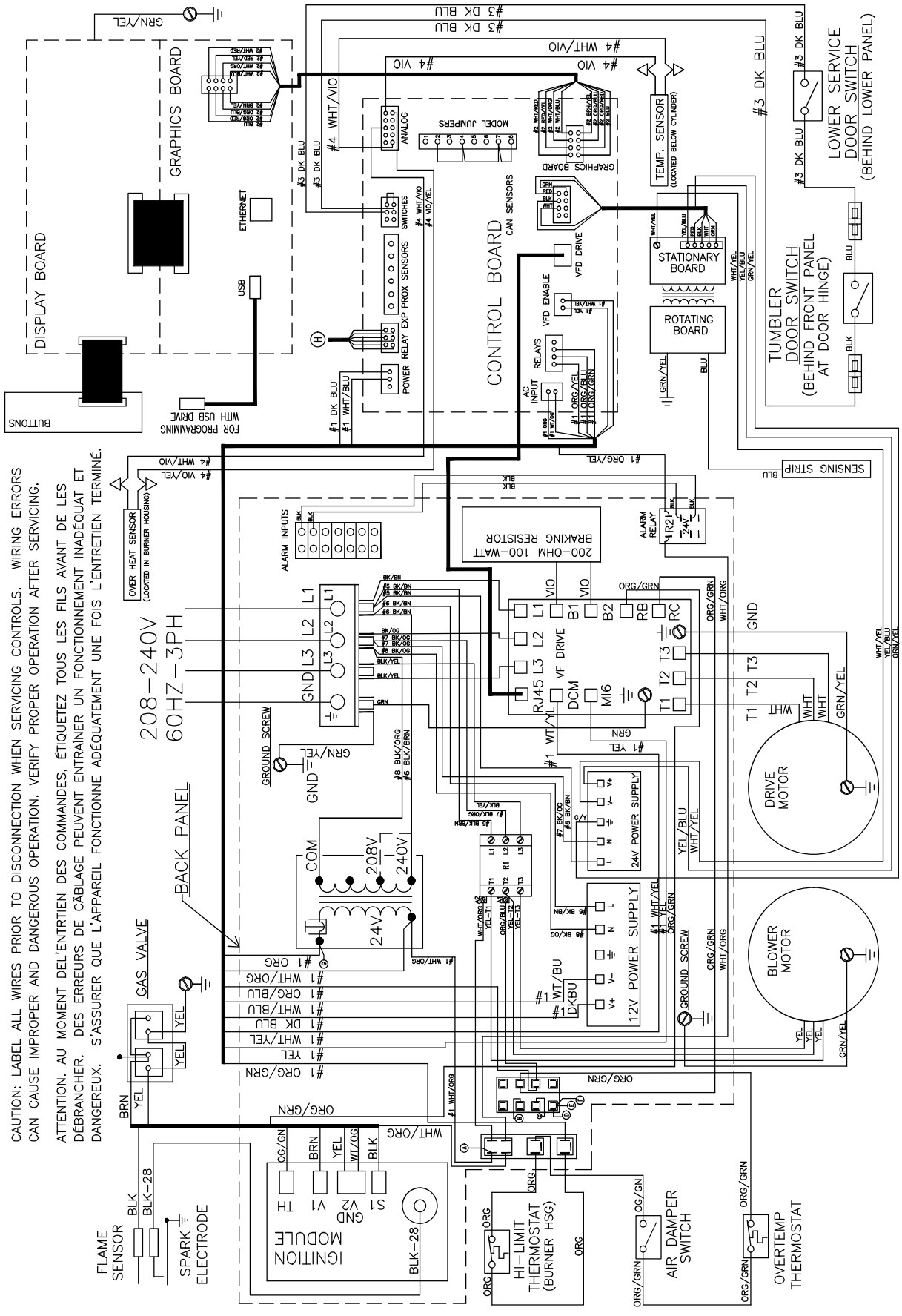

CAUTION: LABEL ALL WIRES PRIOR TO DISCONNECTION WHEN SERVICING CONTROLS. WIRING ERRORS CAN CAUSE IMPROPER AND DANGEROUS OPERATION. VERIFY PROPER OPERATION AFTER SERVICING.

ATTENTION: AU MOMENT DE L'ENTRIEN DES COMMANDES, ÉTIQUETEZ TOUS LES FILS AVANT DE LES DÉBRANCHER. DES ERREURS DE CÂBLAGE PEUVENT ENTRAÎNER UN FONCTIONNEMENT INADÉQUAT ET DANGEREUX. S'ASSURER QUE L'APPAREIL FONCTIONNE ADEQUATEMENT UNE FOIS L'ENTRIEN TERMINÉ.

9507-050-001PR DN0170N\_-13\_0\_B\_---X

WIRING DIAGRAM



---

DN0170NE-39A01\_

# Section 6:

50Hz  
Dryer Parts Data

