

**THE
DEXTER
COMPANY**

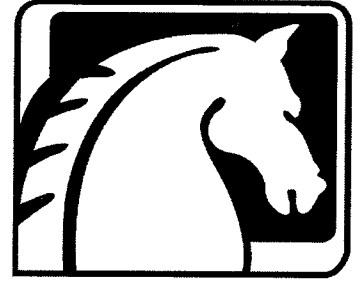

18 LB. COIN OPERATED AND OPL WASHERS

**Thoroughbred 300
WCN 18**

Service Procedures and Parts Data Thoroughbred 300



Fairfield, Iowa 52556

Telephone 641-472-5131
FAX 641-472-6336

WARNING

THESE WASHERS ARE EQUIPPED WITH DEVICES AND FEATURES RELATING TO THEIR SAFE OPERATION. TO AVOID INJURY OR ELECTRICAL SHOCK, DO NOT PERFORM ANY SERVICE, UNLESS QUALIFIED TO DO SO.

A machine should not be allowed to operate if any of the following occur:

- Excessively high water level.
- Machine is not connected to a properly grounded circuit.
- Loading door does not remain securely locked during the entire cycle.
- Vibration or shaking from an inadequate mounting or foundation.

WARNING - FOR SAFETY

1. Always shut off power and water supply and also discharge capacitors before servicing.
2. Do not overload the washer.
3. Do not attempt to open door if cylinder is in motion or contains water.
4. Do not mechanically force or override door lock in any way.
5. Do not bypass any safety devices of this washer.
6. Do not use volatile or flammable substances in or near this washer.
7. Keep all panels in place. they protect against shock and injury and add rigidity to the washer.

Table of Contents

SECTION 1

| | |
|--------------------------|--------|
| Specifications | page 5 |
| Cycle Times | page 5 |
| Water Usage | page 7 |
| Water Temperatures | page 7 |

SECTION 2

| | |
|---|------------|
| Installation & Operation | page 8-14 |
| Foundation Requirements | page 8 |
| Plumbing | page 8 |
| Electrical | page 9 |
| Controls Transformer | page 9 |
| Mounting Dimensions & Concrete Pedestal | page 10ABC |
| Final Check out | page 11 |
| Setting the Accumulator | page 11 |
| Setting the Operating Mode | page 12 |
| Connections for Injection Systems and Rinse Conversions | page 13 |
| Operating Instructions and Detergent Chart | page 14 |

SECTION 3

| | |
|---|------------|
| Wiring Schematics | page 15-17 |
| Start Circuit | page 15 |
| Fill Circuit-Warm | page 16 |
| Wash Circuit | page 16 |
| Drain, Rinse 1 & 2, & Final Rinse Circuit | page 16 |
| Extract Circuit | page 17 |
| Thermoactuator and Shake Out Circuit | page 17 |
| End of Cycle Circuit | page 17 |
| Schematics & Wiring Diagrams | page 19-22 |

SECTION 4

| | |
|--|------------|
| Service Procedures | page 23-35 |
| Top Panel Removal | page 23 |
| Detergent Dispenser | page 23 |
| Vacuum Breaker | page 23 |
| Water Valves | page 23 |
| Circuit Breaker | page 24 |
| Control Mounting Trough | page 24 |
| Coin Accumulator Transformer & Board | page 24 |
| Drop Coin Acceptor | page 24-25 |
| Reversing Timer | page 24 |
| Motor Relays | page 26 |
| Program Timer | page 26 |
| Solid State Start Switch | page 26 |
| Capacitors | page 26 |
| Controls Transformer | page 26 |
| Pressure Switch | page 27 |
| Power Connection Terminal Block | page 27 |
| Cycle Indicator Lights | page 27 |
| Temperature Selector Switch | page 27 |
| Add-Bleach Light | page 27 |
| Lower Service Panel | page 27 |
| Drain Valve | page 27 |
| Front Panel | page 27 |
| Masking Ring (door lock cover) | page 27 |
| Door Lock Assembly | page 28 |
| Door Locking Solenoid | page 31 |
| Thermoactuators | page 31 |
| Loading Door | page 31 |

| | |
|--|------------|
| Loading Door Hinge | page 31 |
| Back Panel | page 32 |
| Drive Belt | page 32 |
| Drive Motor | page 32 |
| Control Panel Name Plate | page 32 |
| Tub Back, Bearing and Cylinder (basket) Assembly | page 33-35 |
| Bolt Torque Chart | page 33 |
| Basket Pulley | page 34 |
| Bearing Housing, Water Seals and Tub Back | page 34-35 |
| Outer Tub | page 36 |
| Cabinet | page 36 |

SECTION 5

| | |
|------------------------|------------|
| Trouble Shooting | page 37-42 |
|------------------------|------------|

SECTION 6

| | |
|---|------------|
| Parts Data | page 43-70 |
| Accessories | page 43 |
| Cabinet and Front Panel Group | page 44-45 |
| Rear View | page 46-47 |
| Chassis and Drain Group | page 48-49 |
| Bearing Housing and Pulley Group | page 50-51 |
| Door Lock Group | page 52-53 |
| Loading Door Group | page 54-55 |
| Control Panel Group | page 56-57 |
| Water Inlet Group | page 58-59 |
| Electrical Components - Top Compartment (Single Phase Only) | page 60-61 |
| Electrical Components - Top Compartment (Three Phase Only) | page 62-63 |
| Coin Handling Group | page 64-65 |
| Water Inlet Valve Breakdown | page 66-67 |
| Drain Valve Group | page 68-69 |
| Wiring Harness Group | page 70 |

SECTION 9

| | |
|--|------------|
| Maintenance | page 71 |
| OPL Cover | page 72-73 |
| Troubleshooting Wiring Schematics Diagrams | page 80-84 |
| Mounting Dimensions | page 10A |
| Parts List | page 86-87 |
| Schematic | page 88-90 |
| Preventive Maintenance | page 91 |

Section 1

Specifications

Thoroughbred 300 Washers

Model Voltage

WCN 18AA120 volts, 60 Hz, Single Phase

WCN 18AB208-240 volts, 60 Hz, Three Phase

T-300 COIN & OPL

Cycle Times

| | Prewash & 3 Rinses | Prewash & 2 Rinses | No Prewash & 3 Rinses | No Prewash & 2 Rinses |
|-----------|-----------------------|-----------------------|--------------------------|--------------------------|
| Prewash | 4 min. | 4 min. | Not used | Not used |
| Drain | 40 sec. | 40 sec. | Not used | Not used |
| Wash | 8 min. | 8 min. | 8 min. | 8 min. |
| Drain | 40 sec. | 40 sec. | 40 sec. | 40 sec. |
| Rinse 1 | 3 min. 45 sec. | Not used | 3 min. 45 sec. | Not used |
| Drain | 40 sec. | Not used | 40 sec. | Not used |
| Rinse 2 | 3 min. 45 sec. | 3 min. 45 sec. | 3 min. 45 sec. | 3 min. 45 sec. |
| Drain | 40 sec. | 40 sec. | 40 sec. | 40 sec. |
| Int. Spin | 50 sec. | 50 sec. | 50 sec. | 50 sec. |
| Rinse 3 | 3 min. 45 sec. | 3 min. 45 sec. | 3 min. 45 sec. | 3 min. 45 sec. |
| Drain | 40 sec. | 40 sec. | 40 sec. | 40 sec. |
| Extract | 4 min. | 4 min. | 4 min. | 4 min. |
| Tumble | 16 sec. | 16 sec. | 16 sec. | 16 sec. |
| Total * | 32 min. | 27.5 min. | 27 min. | 23 min. |

Specifications Chart

| Model | T-300 WCN18 |
|--|----------------|
| Capacity | 18lbs. |
| Dimensions | |
| Cylinder Depth | 13 1/2" |
| Cylinder Diameter | 21" |
| Cylinder Volume (cubic feet) | 2.7 |
| Door Opening | 12 1/4" |
| Door Height (floor to bottom of door) | 14 3/4" |
| Overall Height | 43 7/8" |
| Cabinet Width | 26" |
| Overall Depth | 24 13/16" |
| Drain Diameter (O.D.) | 2 1/4" |
| Drain Height (floor to center of outlet) | 6" |
| Recommended Clearance Between Machines (minimum) | 1/2" |
| Necessary Service Clearance Behind Machine | 24" |
| Cylinder RPM | |
| Tumble Speed | 55 |
| Extract Speed | 560 |
| Extract Speed G-Force | 94 |
| Cylinder Direction in Extract | clockwise |
| Motor H.P. | |
| Wash (single phase) | 0.18 |
| (three phase) | 0.18 |
| Extract (single phase) | 0.6 |
| (three phase) | 0.6 |
| Amperage (average measured on L1) | |
| Wash(three phase) | 2.25 |
| Wash (single phase) | 5.75 |
| Extract (three phase) | 1.25 |
| Extract (single phase) | 7 |
| Running Amps (maximum) | |
| Single Phase | 13 |
| Three Phase | 3.5 |
| Circuit Breaker (amps) | |
| Three Phase | 15 |
| Single Phase | 20 |
| Built-in Controls Circuit Breaker | yes |
| Built-in Motor Protection | yes |

| Model | T-300 WCN18 |
|--|----------------------------------|
| Voltage 60 Hz. ** | |
| Three Phase | 208-240 |
| Single Phase | 120 |
| Service | |
| Three Phase | 3 wire plus ground cord provided |
| Single Phase | cord provided |
| Wire Size (min.) | |
| Three Phase | 12 |
| Single Phase | cord provided |
| Water | |
| Average Water Usage Normal Cycle with Full Load | 34 gal. |
| Maximum Hot Water Use-- Hot cycle with Full Load | 10.5 gal. |
| Recommended Hot Water (degrees) | 140 |
| Water Pressure (min/max) | 30-120psi |
| Water Inlet Size (hose thread) | 3/4" |
| Water Flow Rate (gallons/minute) | 5 |
| Wash Cycle | |
| Normal Wash-Including Fill Time | 24min20sec |
| Normal Wash-Excluding Fill Time | |
| Wash Temperatures | hot, warm & cold |
| Rinse Temperatures | cold-std. warm-opt. |
| Mounting Hole Dimensions | |
| Left to Right | 23 1/4" |
| Front of Cabinet to First Hole | 2 1/2" |
| First Hole to Second Hole | 16 3/4" |
| Second Hole to Third Hole | N/A |
| Mounting Bolt Diameter | 1/2" |
| Hole Diameter in Base | 9/16" |
| Concrete Thickness (min.) | 6" |
| Recommended Mounting Height | 8" |
| Weight | |
| Shipping (lbs.) | 361/1p 351/3p |
| Net (lbs.) | 333/1p 323/3p |

Water Usage T-300 Coin Washer

| | Wash | Prewash | Wash | Prewash |
|-----------|------------|------------|------------|-----------|
| | 2 Rinses | 2 Rinses | 3 Rinses | 3 Rinses |
| Prewash | Not used | 12 gal. | Not used | 12 gal. |
| Wash | 13.75 gal. | 9.25 gal. | 13.75 gal. | 9.25 gal. |
| Rinse 1 | Not used | Not used | 8.35 gal. | 8.35 gal. |
| Rinse 2 | 8.2 gal. | 8.2 gal. | 8.2 gal. | 8.2 gal. |
| Int. Spin | | | | |
| Rinse 3 | 11.5 gal. | 11.5 gal. | 11.5 gal. | 11.5 gal. |
| Total | 33.45 gal. | 40.95 gal. | 41.8 gal. | 49.3 gal. |
| | | | | |

Water Temperatures

| | Heavy Duty | Normal | Perm Press | Delicates |
|---------|------------|--------|------------|-----------|
| Prewash | Hot | Warm | Warm | Cold |
| Wash | Hot | Warm | Warm | Cold |
| Rinse 1 | Cold | Cold | Cold | Cold |
| Rinse 2 | Cold | Cold | Cold | Cold |
| Rinse 3 | Cold | Cold | Cold | Cold |

*Rinses can be converted to warm by moving the Brown/Orange wire on TB-11 to TB-9 (TB-# relates to a terminal number on the large terminal block located in the electrical control trough). **Disconnect electrical power before moving wire.**

Section 2

Installation & Operation

All washers must be installed in accordance with all local, state and national building, electrical, and plumbing codes in effect in the area.

Foundation Requirements

The washer must be securely bolted to a substantial concrete floor, or mounted upon a suitable base which is in turn securely bolted to a substantial concrete floor. Care must be stressed with all foundation work to insure a stable unit, eliminating vibration. All installations must be made on sound concrete floors 6" or thicker.

Mounting

A concrete pad or steel base which elevates the machine 8 inches above the floor level is recommended to provide easy access to the loading door. Allow a minimum of 24" of clearance behind the rear of the machine for service as is shown.

Mounting Holes

The following pages illustrate the mounting dimensions for the machines and also show a typical concrete pad arrangement.

Mounting hole dimensions are shown as either 14 5/16 or 16 3/4 inches front to back spacing and either 23 1/4 or 20 7/8 inches side to side. The 16 3/4 and 23 1/4 spacing is preferable unless current anchors dictate using the alternate spacing.

Note: Mounting bolts should be checked frequently to insure that they remain tight. The machine should be checked with a spinning load to be sure there is no unusual vibration or movement between the machine and the base or floor.

Plumbing

Water supply hoses are furnished with each machine. The threaded connections on the hoses are standard garden hose type thread. Separate hot and cold water lines with shut off valves or faucets for inlet hose connections must be provided, maintaining 30 to 120 p.s.i. water flow pressure. A hot water recovery rate of approximately 28 gallons per hour is required with normal wash and cold rinses. A hot water temperature of 140 degrees Fahrenheit is recommended for best washing results.

Drain

The drain outlet tube at the rear of the machine is 2 1/4" in outside diameter. A flexible hose (Pt. No. 9242-417-002) is available to extend the drain system. Adequate fall must be maintained for proper drainage.

Protective Film

The machine may have protective adhesive film on the front escutcheon area and the front and side stainless steel panels. The film may be peeled off before putting the machine into service.

Electrical

Dexter WCN18AA (1 phase 120 volts) series washers are equipped with an electrical cord with a 3 prong grounded plug. A U.L. approved receptacle, which has been properly grounded in accordance with local electrical codes must be used with the machine. Each unit should be connected to an individual branch circuit not shared by lighting or other equipment. Conductors of the proper size and insulation (suggested size below) should be used.

Dexter WCN18AB (3 phase 208-240 volts) series washers are intended to be permanently installed appliances. The machines should be connected to an individual branch circuit not shared by lighting or other equipment. The electrical connection should be sheathed in water proof flexible conduit, or equivalent, with conductors of the proper size and insulation (suggested size below). A power cord is not provided. The following diagrams show the proper power connections to the rear terminal block for 3 phase machines. Wiring should be performed by a qualified person.

Electrical power connections are made to the small terminal block located in the rear of the control trough. The terminal block is accessed by opening the top panel of the machine.

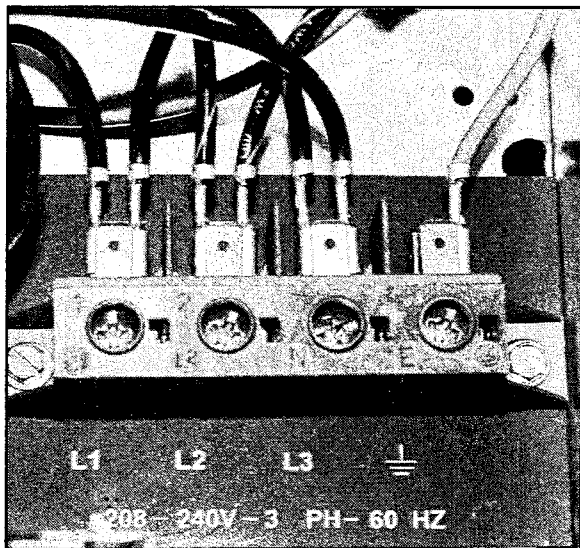

3 Phase
208-240 volts, 60 Hz.
3 wire plus ground

Terminal Block 3 ph

Suggested Minimum Wire Size -- 12 Ga.

Fusing Requirements: Dual element time delay fuse or equivalent breaker of amperage specified below.

| | |
|---------|--------|
| 1 Phase | 20 amp |
| 3 Phase | 15 amp |

Always disconnect electrical power to the machine before performing any adjustments or service work.

Controls Transformer

This transformer is mounted at the back of the control trough and steps a range of 208 to 240 volts down to 115 volts for the controls. There are two terminals on the controls transformer for incoming power. One terminal is for 208 to 220 volts and the other is for 221 to 240 volts.

Note: All 60 Hz. three phase washers have a controls transformer. Single phase washers do not require a controls transformer. Always check the incoming voltage and use the appropriate transformer terminal when installing three phase washers.

300 SERIES COMMERCIAL WASHER MOUNTING DIMENSIONS

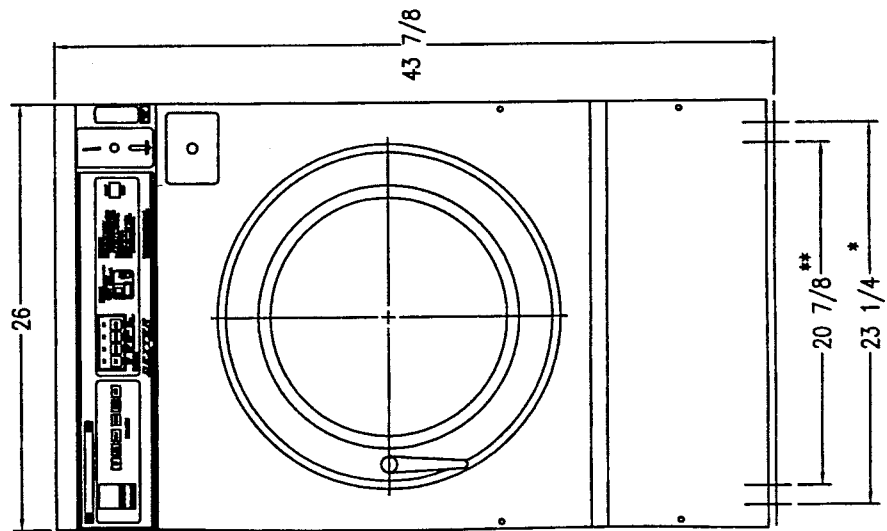

FRONT

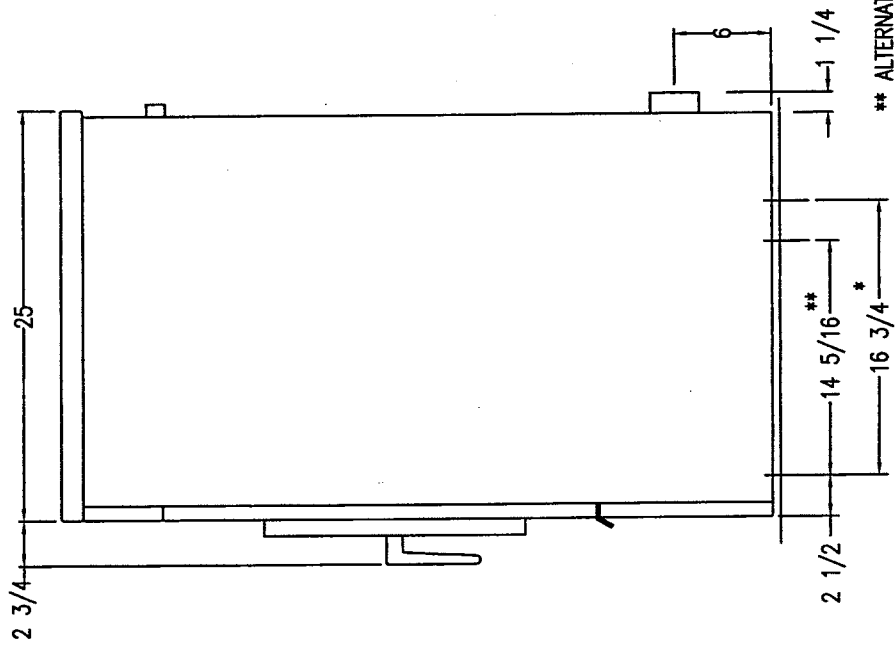

SIDE

** ALTERNATE
* RECOMMENDED

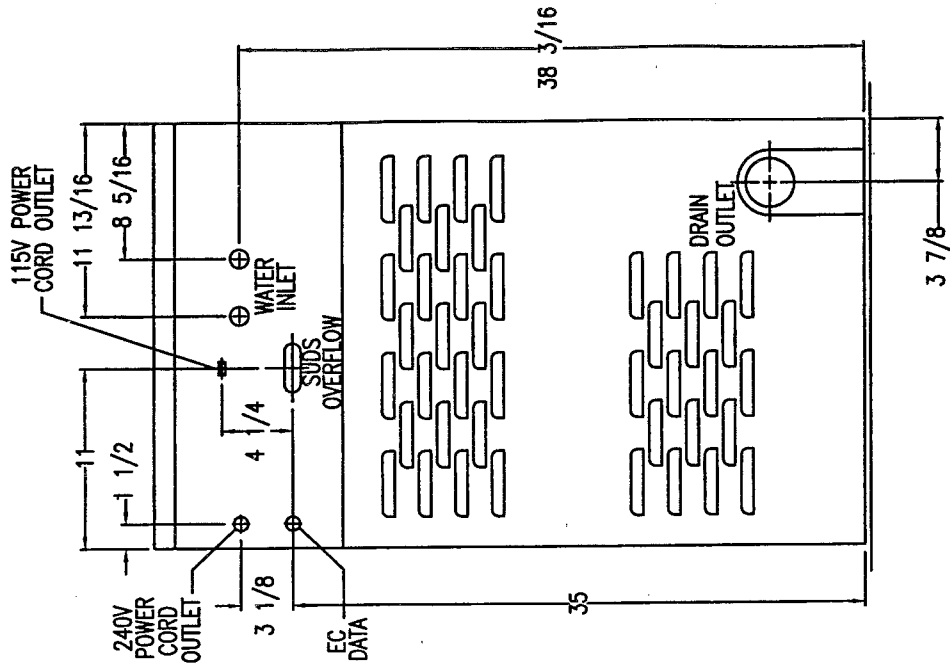

REAR

Final Check out

Always disconnect electrical power to the machine before opening the top. Avoid contact with capacitor or other electrical terminals.

Open the top of the machine as follows:

- Remove the four screws that hold the dispenser to the top panel.
- Unlock the top panel, slide to the rear to release and remove the top panel from the machine.

Setting the Accumulator

Always disconnect electrical power to the machine before setting the accumulator. Avoid contact with capacitor or other electrical terminals.

The accumulator board contains the digital coin count and time remaining display and is attached to the front of the machine. The **amount to start** is set by depressing the 6 small switches on the top edge of the accumulator in the correct combination for the desired number of coins. The **time remaining** is set by depressing the other six small switches on the top edge of the accumulator in the correct combination for the desired cycle time. (See chart for correct combinations) The switch numbers and names are printed on the clear cover over the coin accumulator circuit board. The switches are actuated by pushing the switch lever toward the back of the machine. As the switches are very small, a golf tee or some other nonmetallic tool is desirable for this process.

Note: For use in Canada, the coin acceptor magnet must be removed. See drop coin acceptor in Service Procedures Section for location of magnet.

| Number of Coins or Minutes | Switch Number | | | | | |
|----------------------------|---------------|---|---|---|---|---|
| | 1 | 2 | 3 | 4 | 5 | 6 |
| 1 | X | | | | | |
| 2 | | X | | | | |
| 3 | X | X | | | | |
| 4 | | | X | | | |
| 5 | X | | X | | | |
| 6 | | X | X | | | |
| 7 | X | X | X | | | |
| 8 | | | | X | | |
| 9 | X | | | X | | |
| 10 | | | | | X | |
| 11 | X | | | | X | |
| 12 | | X | | | X | |
| 13 | X | X | | | X | |
| 14 | | | X | | X | |
| 15 | X | X | X | | X | |
| 16 | | X | X | | X | |
| 17 | X | X | X | | X | |
| 18 | | | | X | X | |
| 19 | X | | | X | X | |
| 20 | | | | | | X |
| 21 | X | | | | | X |
| 22 | | X | | | | X |
| 23 | X | X | | | | X |
| 24 | | | X | | | X |
| 25 | X | X | | | | X |
| 26 | | X | X | | | X |
| 27 | X | X | X | | | X |
| 28 | | | | X | | X |
| 29 | X | | | X | | X |
| 30 | | | | | X | X |
| 31 | X | | | | X | X |
| 32 | | X | | | X | X |
| 33 | X | X | | | X | X |
| 34 | | | X | | X | X |
| 35 | X | X | X | | X | X |
| 36 | | X | X | | X | X |
| 37 | X | X | X | | X | X |
| 38 | | | | X | X | X |
| 39 | X | | | X | X | X |

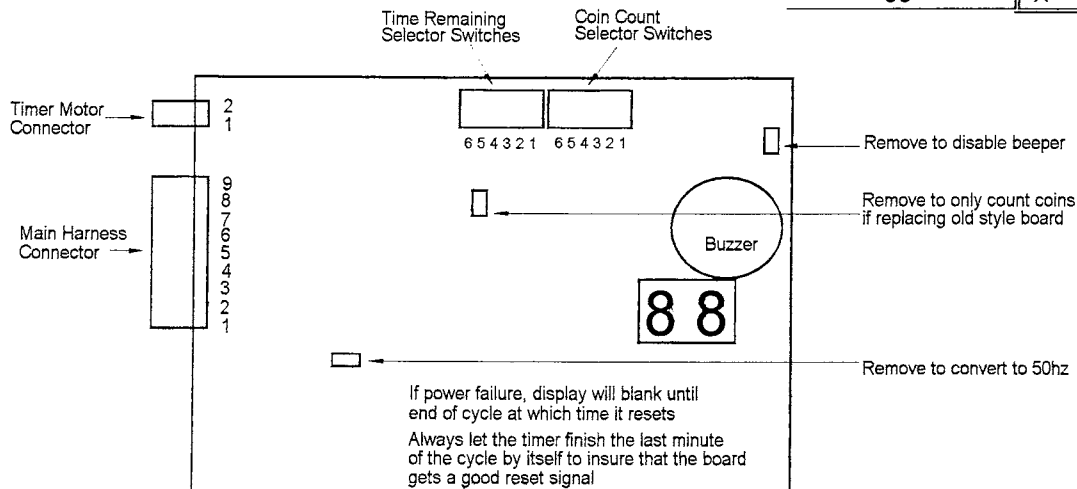

Setting the Operating Mode (Program length)

See the Cycle Time Chart in Section 1 for the four available Cycle Times.

The operating mode can be selected by connecting the orange/white wire, located under the main timer, to the wires listed below. Machines are shipped with the orange/white wire connected to the blue/orange wire giving no prewash and 2 rinses. Reconnecting the end of the orange/white wire with the plastic housing from the blue/orange wire to the following wires gives these selections:

- No wire, tape up end of orange/white wire gives prewash and 3 rinses
- Connecting to blue/red wire gives prewash and 2 rinses
- Connecting to blue/yellow wire gives no prewash and 3 rinses
- Connecting to blue/orange wire gives no prewash and 2 rinses

After changing the operating mode (program length), refer to Setting the Accumulator on the previous page to reset the cycle time remaining for the correct length of time for the new cycle.

Close top, replace screws in dispenser, lock top and reconnect power.

After all mounting, plumbing and electrical work is completed, the washer should be run through a cycle and checked for water leaks and proper functioning.

Connections for Injection Systems and Rinse Conversions

Connections for Injection Systems

Signals for the connection of chemical injector systems are available at the connection points listed below. These points will give 120VAC signals.

| DESCRIPTION | TERMINAL LOCATION |
|-------------|---|
| Prewash | This connection maybe made at the prewash light at the front of the machine. The wire color to piggyback on is yellow/black. |
| Bleach | This connection maybe made at the bleach light at the front of the machine. The wire color to piggyback on is yellow/green. |
| Wash | This connection maybe made at the wash light at the front of the machine. The wire color to piggyback on is yellow/orange. |
| Rinse | This connection maybe made at the rinse light at the front of the machine. The wire color to piggyback on is yellow/blue. Be sure not to use the final rinse light. |
| Final Rinse | This connection maybe made at the final rinse light at the front of the machine. The wire color to piggyback on is yellow/white. |

Connection for Warm Rinses

As shipped from the factory all rinses are cold. Rinses can be converted to warm by moving the brown/orange wire on the terminal block from the front left terminal with the red/blue wire to the back right terminal with the white/orange wire. **Disconnect electrical power before moving the wire.**

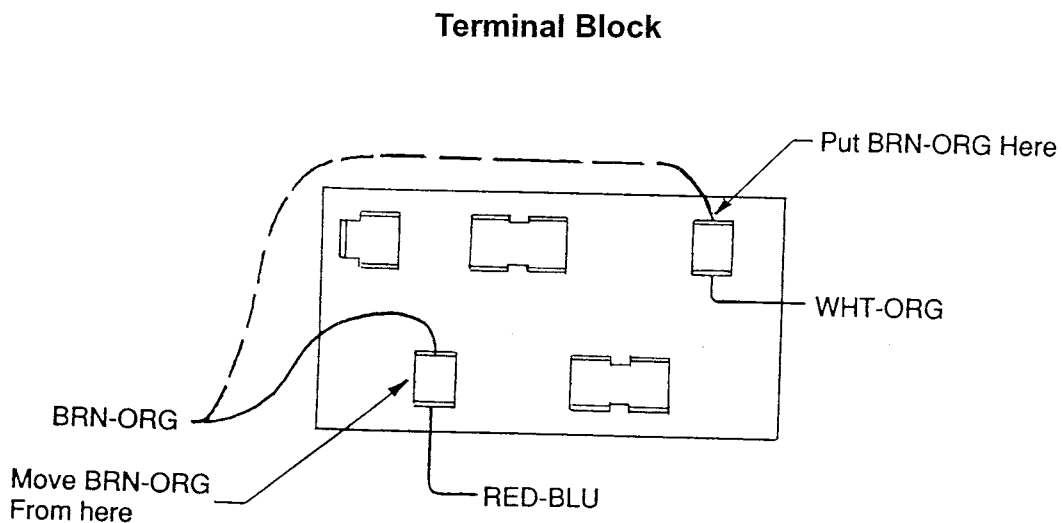

Operating Instructions

Accumulator

Prior to operation, the coin accumulator should be set for both the number of coins to start and the number of minutes in the cycle. (see Setting the Accumulator)

Starting the Washer

- A. Pour low-sudsing powdered detergent in the amount shown below into the detergent dispenser on top of the machine. Rinse conditioners may also be added to the dispenser. The correct location is shown on the dispenser lid.



T-300

- B. Load the clothes loosely in the cylinder and latch the door securely. Be sure clothing does not get caught between the door gasket and tub front when closing the door.

NOTE: To close the door the handle must be in the horizontal position . After moving the door to the closed position, the handle must be turned down to the vertical position to latch the door for machine operation.

- C. Using the buttons on the front, select the wash cycle having the desired temperature.
- D. Insert the preset number of coins as shown in the coin display to start the machine. The washer will automatically start and the red on light will glow. The clothes door will lock and remain locked until the end of the cycle.
- E. At the correct time in the cycle the green ADD BLEACH light will come on indicating the time and location for adding bleach if desired.

End of Cycle

When the cycle is completed, the end of cycle beeper will sound and the on light will go off. The loading door can now be opened by turning the door handle to the indicated position and pulling. Leave the clothes door open when the machine is not in use. Also, at the end of cycle the coin count display will reset to the original number of coins required to start.

Section 3

Wiring Schematics

Timer Sequence Chart

The timer sequence charts are used in conjunction with the wiring diagrams to trace the circuitry during the timer cycle. The timer contacts and the operation or component that each contact controls are listed down the left side of the chart. The phases of the complete cycle are shown across the bottom of the chart. The timer switch increments are numbered across the top of the chart. The solid horizontal bars in the chart denote when the various contacts are closed during the cycle.

To use the timer sequence chart to trace the circuitry:

1. Locate the particular part of the cycle on the sequence chart.
2. Determine which timer contacts are closed during that particular step of the cycle by noting the solid vertical bars in that step across the chart.
3. Draw in the gap of the respective contacts on the wiring diagram with a soft dark pencil, to illustrate the contacts as being closed.
4. Similarly, determine which switch contacts are closed, by the switch chart, and illustrate them as closed on the wiring diagram.
5. The circuitry during the particular step of the cycle may then be easily traced on the wiring diagram, since all contacts and switches are then properly illustrated as being open or closed.

18lb. Washer Schematic

Start Circuit

Power travels into the machine on L1 & L2 (3 phase) or L1 & N (1 phase). On 3 phase, 240VAC goes to a Control Transformer that steps the voltage down to 120VAC for the controls. 120VAC then travels to the 1.5 amp Circuit Breaker. On 1 phase, 120VAC goes directly to the 7 amp Circuit Breaker. There is no need for a step down transformer.

From the Circuit Breaker, 120VAC travels on the black/red wire to the Coin Accumulator Transformer where it is stepped down to 12VAC. This 12VAC powers the Coin Accumulator Board via the gray wire. With the board now powered up, the insert coins light will be illuminated and it's ready to count coins. 120VAC is also supplied to the Main Timer Start and On-Off Contacts on the black/red wire. The Start Contact is closed before the machine has been started so 120VAC travels through the Start Contact and is supplied to the Coin Accumulator Board Start Relay. The S4 Coin Switch counts the quarters and sends a signal to the Coin Accumulator Board. When the coin count is satisfied, the Coin Accumulator Board closes the Start Relay and sends a short 120VAC signal on the orange/white wire to the Rapid Advance Timer Motor. This timer motor starts advancing the Main Timer to the preselected starting position. A few seconds after the Coin Accumulator Board sends the start signal to the Rapid Advance Timer Motor, the Coin Accumulator Start Relay opens, the display goes blank and the On-Off Contact in the Main Timer closes to insure that the S1 Door Switch is closed (showing that the door is locked). The On-Off Contact also provides 120VAC to the On Light on the red wire. With the S1 Switch closed, the Door Lock Solenoid is now powered with 120VAC via the white/red wire. The Door Lock Solenoid pulls in, locking the door and closing the S2 and S3 Switches. The S2 Switch is a backup to the S1 Switch so that the adjustment on S1 isn't as critical. The S3 Switch provides 120VAC to Timer Contact RA-3 to power the Rapid Advance Motor again and the Main Timer is allowed to advance on to the preselected start position. The blue wire furnishes the neutral for the controls.

Fill Circuit-Warm

120VAC is supplied to the controls through the S1, S2, and S3 Door Switches. The On Light and the Door Lock Solenoid (discussed in Start Circuit) will remain on throughout the cycle as well as the Main Timer Motor. The Lock Thermoactuator Contact in the Main Timer is closed and provides the neutral side to operate the Lock Thermoactuator. This contact cycles open and closed keeping the Lock Thermoactuator activated until 1 1/2 minutes before the end of the cycle. At this point the contact opens and removes power to the Lock Thermoactuator. 120VAC is provided to the Lock Thermoactuator on the orange wire from the S3 Door Switch. The Drain Contact in the Main Timer is closed and provides 120VAC to the Drain Valve on the brown/yellow wire which closes the valve. The Wash Motor Contact in the Main Timer is closed and provides 120VAC to the Reversing Timer and the Reversing Timer Motor on the blue/black wire. This will start the Reversing Timer operating which will alternately open and close the Micro Switches that provide the direction of tumble for the wash basket. The Wash Light Contact in the Main Timer is closed and provides 120VAC to the Wash Light. The orange wire coming from the S3 Door Switch provides power to the Wash Water Contact in the Main Timer. 120VAC connects from the Wash Water Contact to the Wash Temperature Contact via an internal timer connection.

With 12VAC on the orange wire & neutral on the orange/yellow wire, the Coin Accumulator Board turns on the Time Remaining Light & starts counting down in minutes. (If delay fill kit is installed, time count down is stopped during fills.)

Now a cycle must be selected with the Selector Switch. We'll use Normal Wash. The washer fills the tub through the back of the machine with either one or both the C1 Cold and H1 Hot Water Valves. At the beginning of the cycle, the detergent dispenser flushes the detergent into the tub. This is accomplished with the Wash Dispenser Contact in the Main Timer. 120VAC travels through the closed Wash Dispenser Contact and is supplied to the H2 Hot Water Valve Solenoid by the red/orange wire. As the washer fills with water, the Wash Basket will tumble one direction for 19 seconds, pause, and then reverse direction for 19 seconds. 120VAC travels from the Wash Water Timer Contact to the Heavy Duty Contact in the Selector Switch via the white/black wire. 120VAC goes through the closed Heavy Duty Contact in the Selector Switch and energizes the C1 Cold Water Valve Solenoid via the white/orange wire. 120VAC also travels to the closed Wool/Delicate Contact in the Selector Switch. This closed contact provides power to the H1 Hot Water Valve Solenoid via the red/yellow wire. When the water reaches the predetermined level the Pressure Switch moves to the full position and opens the neutral side of the line to the Water Valves. This shuts the Water Valves off.

Wash Circuit

As the washer fills the tub through the back of the machine with either one or both the C1 Cold and H1 Hot Water Valves, the Wash Basket will tumble one direction for 19 seconds, pause, and then reverse direction for 19 seconds. This is accomplished through the use of a Reversing Timer. 120VAC is supplied to the Reversing Timer Motor on the blue/black wire from the Wash Motor Timer Contact in the Main Timer. With 3 phase power, the Reversing Timer will alternately open and close the two Wash Micro Switches and provide 120VAC to the R1A (brown/white wire) and R1B (orange/green wire) Wash Contactor Coils. These coils open and close the Contactor Switches to operate the Drive Motor. With 1 phase power, there are no Wash Relays. 120VAC is provided directly to the motor by the Reversing Timer. 120 VAC on the black/orange wire is for counter clockwise and 120VAC on the black/white is for clockwise direction.

As discussed in Start and Fill, the Thermoactuator, Drain Valve, On Light, and Main Timer Motor are all operating throughout the Wash Cycle.

Drain, Rinse 1 & 2, & Final Rinse Circuit

The Drain Contact in the Main Timer opens removing power to the Drain Valve. The normally-open spring-loaded Drain Valve opens and empties the tub.

For Rinse 1 & 2, the Rinse Light Contact in the Main Timer closes and provides 120VAC to the Rinse Light. The Rinse Water Contact in the Main Timer also closes and provides 120VAC to the C1 Cold Water Solenoid. The tub will fill until the predetermined level is achieved at which time the Pressure Switch Contact will open the neutral side of the line shutting off the C1 Cold Water Solenoid.

For the Final Rinse, the Final Rinse Light Contact in the Main Timer closes and provides 120VAC to the Final Rinse Light. Rinse water is the same as in Rinse 1 & 2 above.

Extract Circuit

The Spin Contact in the Main Timer closes to provide 120VAC to the Spin Light. The Wash Motor Contact remains closed and provides 120VAC to the closed Clockwise Micro Switch on the Reversing Timer. 120VAC is then fed to the Counter Clockwise Micro Switch via a jumper wire. Power is then sent through the Counter Clockwise Micro Switch to the Delay Spin Micro Switch. The Delay Spin Micro Switch provides 120VAC to the Spin Motor Contact in the Main Timer on the blue/white wire. The Spin Motor Contact is closed for spin and the voltage continues on to the R2 Spin Motor Contactor Coil on the red/black wire. With 120VAC to the R2 Spin Motor Contactor Coil the Contactor is pulled down (closed) and two things happen. With the R2 Contactor closed, 120VAC is now provided from the orange wire directly to the Contactor eliminating the Reversing Timer and the Micro Switches from the circuit.

The second thing that happens when the R2 Contactor is closed is that voltage is provided directly to the Spin Winding in the motor on 3 phase machines and the washer spins.

On 1 phase washers, the R2 Contactor provides 120VAC to the Main Spin Winding and also provides 120VAC to the Spin Capacitors. The Spin Capacitors then provide 120VAC to the Phase Spin Winding.

Thermoactuator and Shake Out Circuit

The Lock Thermoactuator Contact in the Main Timer opens 1 1/2 minutes before the end of the cycle removing the neutral to the Thermoactuator. This allows the Thermoactuator time to retract by the end of the cycle.

To insure that the Lock Thermoactuator has retracted by the end of the cycle, 1 minute prior to the end of the cycle, the Unlock Thermoactuator is powered with 120VAC through the Unlock Thermoactuator Contact in the Main Timer.

The Spin Motor Contact in the Main Timer opens, stopping voltage to the R2 Spin Motor Relay & the motor. The basket will coast to a stop. The Wash Motor Contact in the Main Timer closes providing power to the Reversing Timer once again (discussed in Wash Cycle). The washer will tumble for approximately 30 seconds to let the clothes shake loose and then stop.

End of Cycle Circuit

The On-Off Contact in the Main Timer opens removing power to the Door Lock Switches and Contactors. The machine is now stopped. The Start Contact on the Main Timer is closed providing 120VAC to the Coin Accumulator Board on the white/green wire. The End Of Cycle Contact in the Main Timer is closed sending a 120VAC signal to the Coin Accumulator Board on the white/yellow wire telling it that the cycle is over. This resets the Coin Accumulator Board and it is now ready to count coins again.

T-300 Wiring Schematic 1 phase

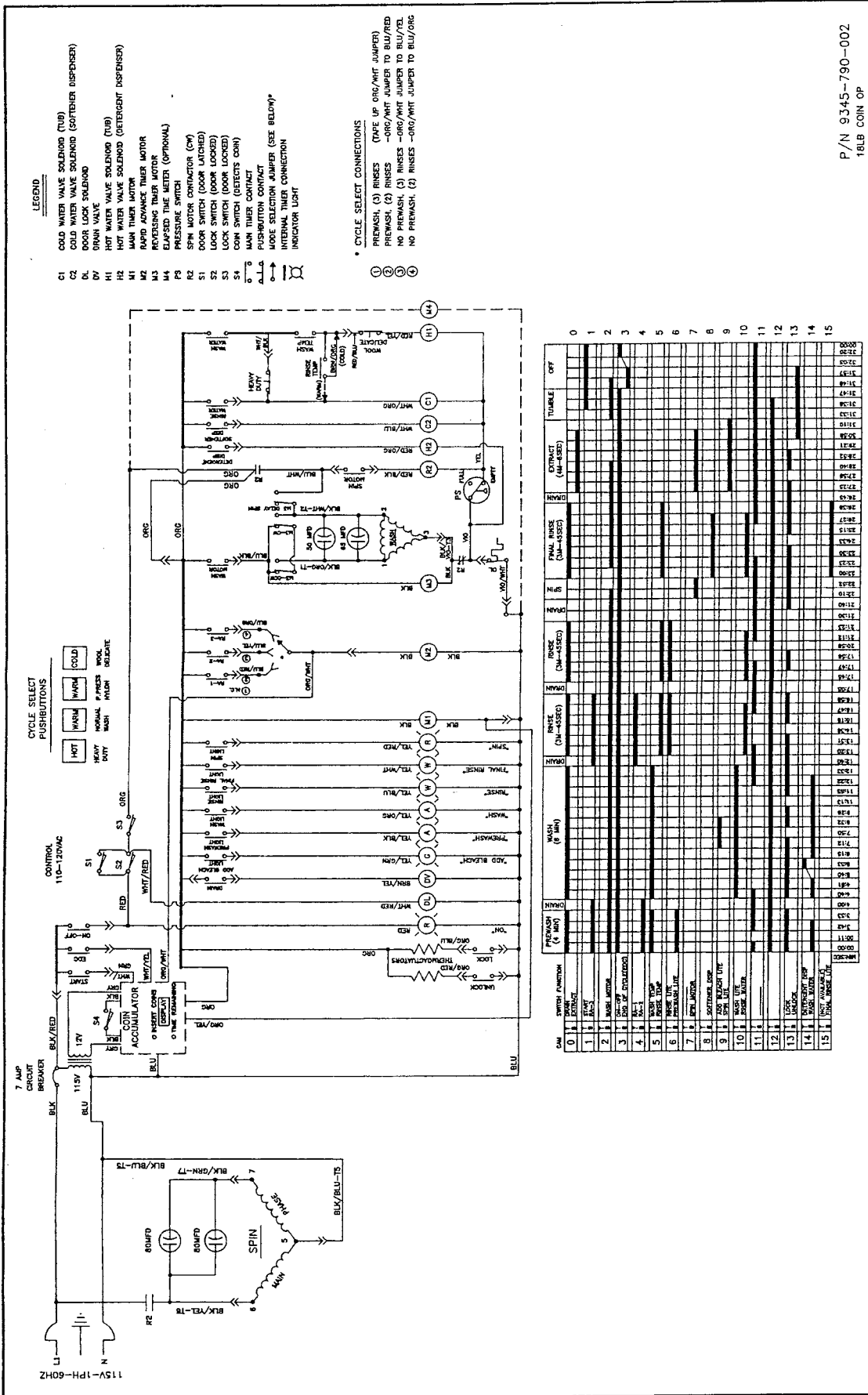

P/N 9345-790-002
18LB COIN OP

WIRING SCHEMATIC 115V-1PH-60HZ

Single Phase Wiring Diagram

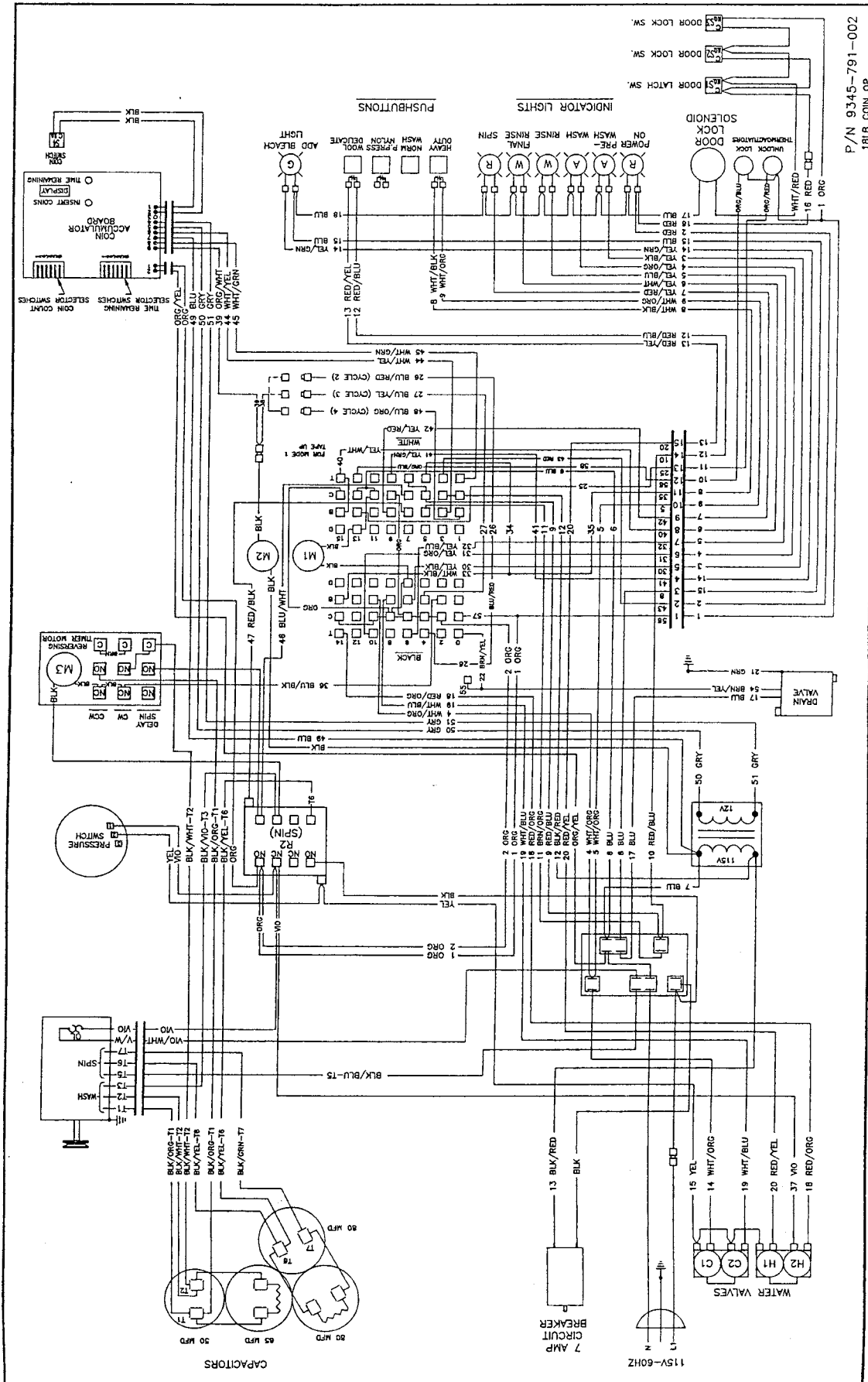

P/N 9345-791-002
18LB COIN OP

WIRING DIAGRAM 115V-1PH-60HZ

Three Phase Wiring Diagram

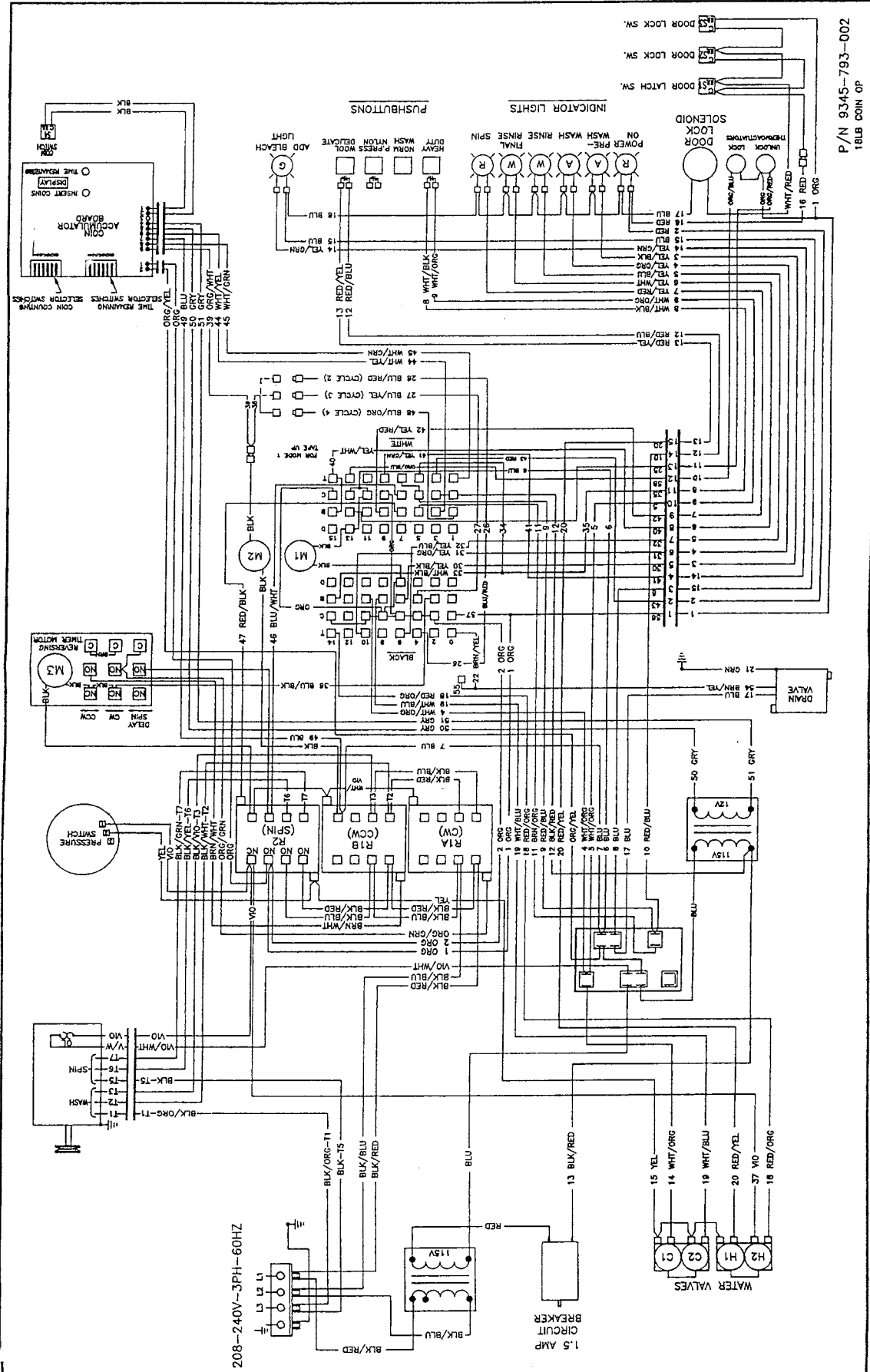

WIRING DIAGRAM 208-240V-3PH-60HZ

P/N 9345-793-002
1BLB COIN OP

Section 4

Service Procedures

Before performing any service work, remove electrical power from the machine.
Always replace panels before putting machine into service.

Top Panel Removal

- A. Remove 4 screws that hold detergent dispenser to top panel.
- B. Unlock top panel lock.
- C. Raise top panel, slide to the rear to release from back clips and lift off.

Detergent Dispenser

Remove top panel to access dispenser. (see Removing Top Panel)

Detergent is flushed from the front of the compartment and fabric softener is flushed from the back. There will be a small amount of water left in the fabric softener compartment after each use. This is normal.

Vacuum Breaker

In the left rear of the cabinet is the vacuum breaker. It guides the water to the tub and dispenser and prevents a back flow of water.

Water Valves

Remove top panel to access water valves. (see Removing Top Panel) The two dual outlet water valves are mounted to the rear channel with two screws each. Always check inlet screens to be sure that they are clean. Disassembly requires the removal of two solenoid screws and three valve body screws. Below the solenoid coil is a solenoid guide, armature, armature spring and diaphragm. All valve parts are available individually or as a complete unit.

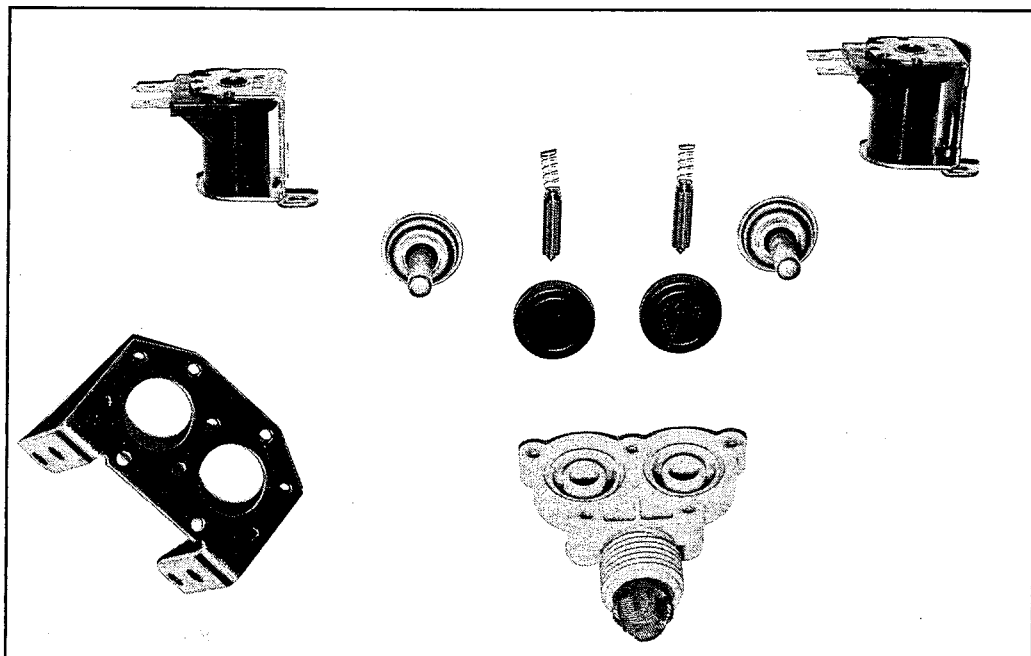

Circuit Breaker

The circuit breaker mounts to the rear channel. On the WCN18AA (1 phase 120 volts), the 7 amp circuit breaker carries all of the controls as well as the motor wash windings. On the WCN18AB (3 phase 208-240 volts), the 1.5 amp circuit breaker carries all of the controls in the machine but does not include the motor. To reset the circuit breaker just push in the button.

Control Mounting Trough

Remove top panel to access control trough. (see Removing Top Panel) It sets on the right side of the machine and holds many of the controls.

Coin Accumulator Transformer

This transformer that powers the coin accumulator board is mounted on the left side of the control trough. It steps control voltage down to a 12 volt AC output. It is held in place with two screws.

Coin Accumulator Board

This board displays the number of coins to start the washer, counts down the number of coins as they are added and starts the program timer when the preset coin amount is satisfied. With the preset coin amount satisfied, the coin accumulator closes a circuit sending control voltage to the timer on the orange with a white striped wire and starts the washer. At the end of the cycle, the timer closes the end of cycle cam providing control voltage on the white with a yellow striped wire to the coin accumulator board. This signal from the timer resets the accumulator board so it is ready to count coins and the display goes back to the original amount of coins needed to start the washer. 12 volt AC power for the coin accumulator is supplied by the coin accumulator transformer discussed above. The board is retained by three nuts.

Drop Coin Acceptor

The drop style coin acceptor contains a coin switch that is actuated by each good coin that is accepted.

Removal

The coin acceptor is removed by loosening the two Torx T-10 machine screws on the right side and by removing completely the two Torx T-10 machine screws on the left side (#T-10 Torx driver, Dexter Pt. No. 8545-051-003). There are locking nuts on the back side that will have to be held. Needle-nose pliers work well for this. Sliding the acceptor to the left will remove it from the slots in the front panel. This gives access to the coin switch and acceptor for adjustments.

Coin Thickness Adjustment (see diagram)

On the right side of the acceptor there is a coin thickness adjusting screw "A" with a locking nut. To allow for different thickness coins the screw can be turned in to accept thicker coins and turned out to reject thicker coins. Start with a quarter of a turn on this screw and be sure to retighten the lock nut after adjustment.

Coin Height Adjustment (see diagram)

On the left side of the acceptor is a coin height adjusting bar "B". This bar is adjusted by loosening the two mounting screws and moving both ends of the bar up or down equal amounts. The bar should be raised as high as possible while still accepting the correct coins. If it is raised up too high, the good coins will be rejected.

Coin Switch Adjustment (see diagram)

The normally open coin switch "C" should click (close) soon after the coin hits the operator wire. However, there must be enough travel to allow the switch to reset (open) once the coin has passed. Adjustment should be made by bending the wire very close to its attachment point.

Reversing Timer

The reversing timer operates the wash and spin relays and is mounted on the left side of the control trough and retained with two screws. It has three cam operated switches. Two switches operate the wash cycle by alternately engaging the wash relays to tumble counter clockwise for 19 seconds, stop for 3 seconds, reverse direction and tumble clockwise for 19 seconds. The third switch engages the spin relay for the high speed spin portions of the cycle.

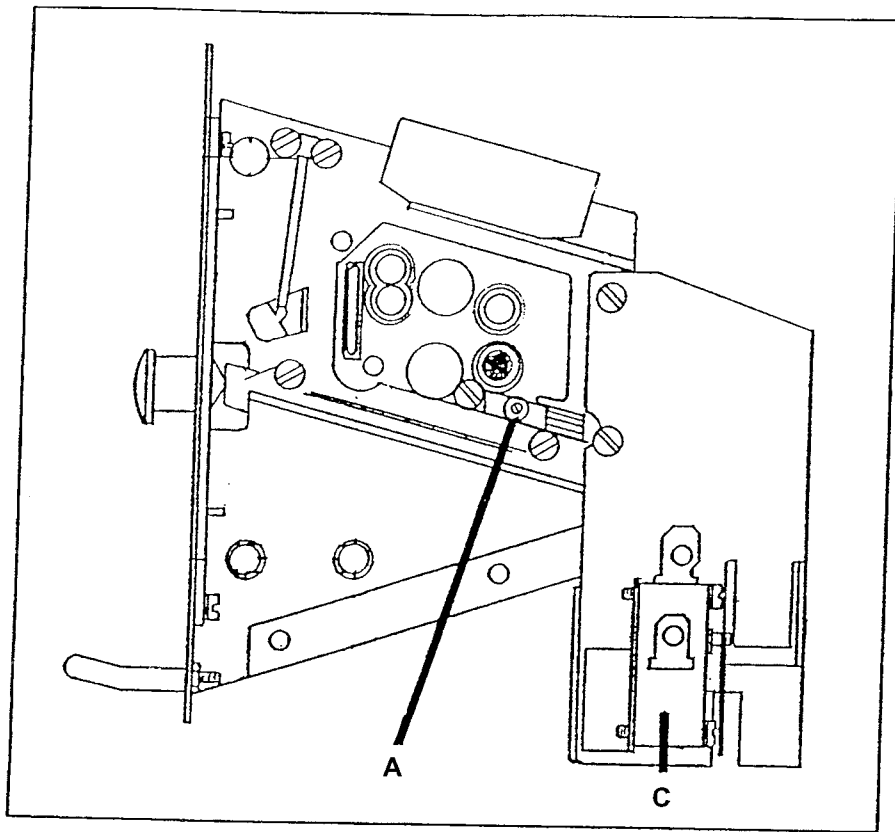

COIN ACCEPTOR - right side

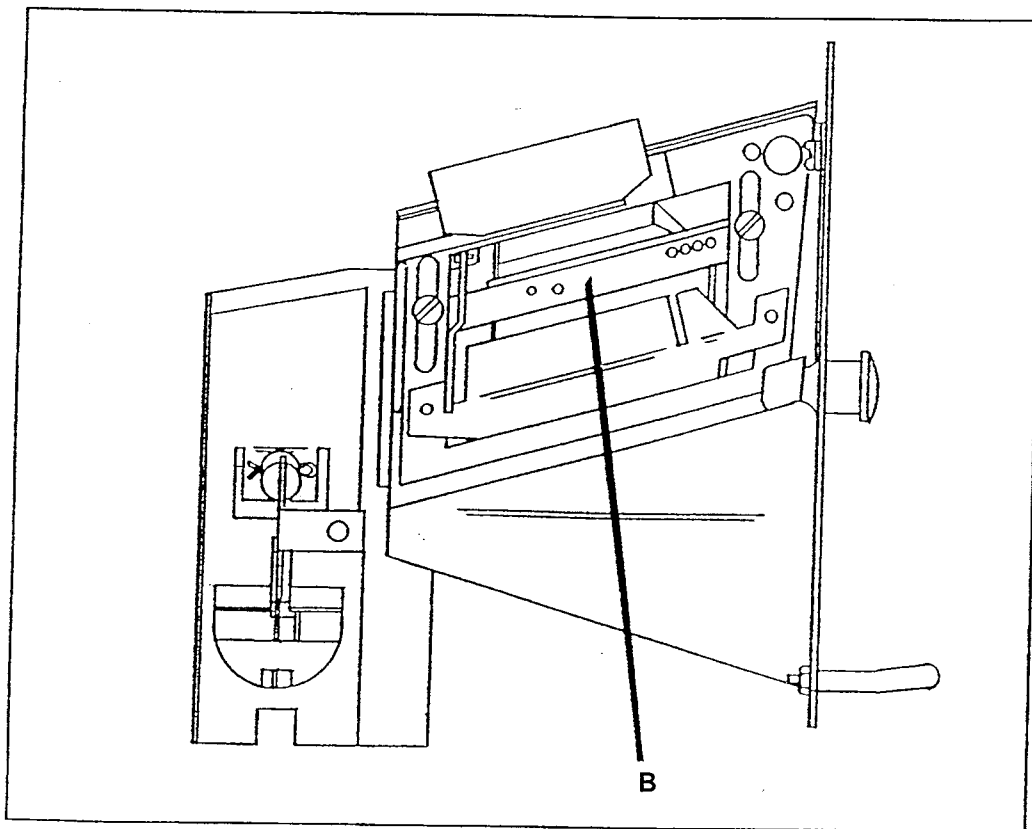

COIN ACCEPTOR - left side

Motor Relays

These relay(s) are located in the center of the control trough. 1 phase washers have only a spin relay. 3 phase washers have 3 relays. The right relay is for spin. The middle and left are wash relays. The middle one is for counter clockwise direction and the left one is for clockwise direction. Wires are removed using a straight blade screwdriver. The relays are removed by prying out on the mounting tab at the bottom of the relay with a straight blade screwdriver.

R1A Wash Motor Relay--3 phase only (clockwise)

The R1A Wash Motor Relay is mounted to the left of the R1B wash motor relay. The 120VAC coil on the wash relay is energized by the clockwise-wash micro switch in the reversing timer. The coil opens and closes the relay switches to operate the drive motor.

R1B Wash Motor Relay--3 phase only (counter clockwise)

The R1B Wash Motor Relay is the middle relay. The 120VAC coil on the wash relay is energized by the counter clockwise-wash micro switch in the reversing timer. The coil opens and closes the relay switches to operate the drive motor.

R2 Spin Motor Relay--1 & 3 phase

The R2 Spin Motor Relay is mounted to the right of the R1B wash motor relay. The 120VAC coil on the spin relay is energized when the delay-spin micro switch in the reversing timer sends 120VAC to the spin motor contact in the timer. The coil opens and closes the relay switches to operate the drive motor.

Program Timer

This timer is located in the front of the control trough and is held in place with two screws. It controls most machine functions. There are two drive motors on the program timer. The one towards the right advances the timer at the beginning of the cycle. The timer motor towards the left drives the timer throughout the cycle. These two motors can be replaced individually. The program timer has a black knob that allows the timer to be manually turned to any portion of the cycle for diagnostic purposes.

Note: All single phase 18lb. washers have wash and spin run capacitors. Three phase machines do not require these parts.

Always discharge capacitors before servicing.

Capacitors

The capacitors are located in the right rear corner of the control trough. The capacitors have metal cases. They are 50 MFD. and 65 MFD on run capacitors. The spin capacitors are both 80 MFD.

Controls Transformer

This transformer is mounted at the left rear corner of the control trough and steps a range of 208 to 240 volts down to 115 volts for the controls. There are two terminals on the controls transformer for incoming power. One terminal is for 208 to 220 volts and the other is for 221 to 240 volts.

Note: All 60 Hz. three phase washers have a controls transformer. Single phase washers do not require a controls transformer. Always check the incoming voltage and use the appropriate transformer terminal when installing three phase washers.

Pressure Switch

The pressure switch sets the water level in the washer. As the water level rises, it compresses the air in the pressure switch hose. When the washer reaches the desired water level, the compressed air in the pressure switch hose opens the contacts in the switch, shutting off the water. When at the empty level, the pressure switch contacts are closed allowing the machine to either spin or fill with water. The 1/4" screw in the middle of the switch adjusts the water level. Turning it clockwise 1/8 of a turn will raise the water level 1/4 of an inch. Counter clockwise will lower the water level. Before making any adjustments of the pressure switch, drain the tub and blow the hose clear of possible water bubbles which can cause erratic pressure switch operation.

With no load, the water level should be approximately 1/2" up from the bottom of the glass.

Power Connection Terminal Block--3 phase only

This terminal block sets at the very back of the control trough. Incoming power to the washer should connect here. (see Electrical under Installation and Operation Section for exact connections)

Cycle Indicator Lights

The 120VAC indicator lights are mounted to the back of the control panel and are held in place with two tabs. They are removed by squeezing the tabs with a screw driver. The lights are replaced as a complete unit.

Temperature Selector Switch

The selector switch is mounted in the center of the control panel and is held in place with two nuts. It allows the selection of hot, warm or cold water temperatures.

Note: Do not over tighten on reinstallation as the switch can be damaged.

Add-Bleach Light

This 120VAC light indicates to the user the correct time to add bleach. It is removed by squeezing two mounting clips.

Lower Service Panel Removal

Remove 2 screws and pull forward to disengage from the locator studs.

Drain Valve

The drain valve is a ball type and is powered closed by the drain valve motor. It is mounted under the washer tub on the left side. It is spring loaded open. If power is interrupted to the washer, the motor releases the sealing ball, allowing the drive spring to open the valve. With the valve open, all water in the washer will drain out.

Service

For access to drain valve, remove lower service panel.

Cleaning

- A. Loosen the clamp on the tub hose at the drain valve end and remove the hose from the drain valve.
- B. Loosen the drain hose clamp on the back of the drain valve.
- C. Remove two drain valve mounting bracket screws from the frame of the washer.
- D. Remove the drain valve and bracket assembly.
- E. Unplug the wiring after the drain valve is removed from the washer.

Front Panel Removal

- A. Remove 2 screws between front panel top and front channel (located behind control panel).
- B. Remove the two screws in the middle of the front panel.
- C. Pull panel out at the bottom to about a 45 degree angle to detach the top lip and remove.

Masking Ring (door lock cover) Removal

- A. Remove front panel.
- B. Remove nuts that retain masking ring.
- C. Move it to the left and off.

Door Lock Assembly

After removing the front panel and trim ring, the door lock assembly can now be accessed.

Operation

After loading the clothing, the door should be closed and latched. The locking cam on the door contacts the latching switch actuator which closes the latching switch. The specified number of coins should now be added to start the washer. This satisfies the coin accumulator which powers the timer rapid advance motor. A timer contact provides power to the latching switch and with the door latched, the power travels through the latching switch to the door lock solenoid. This solenoid pulls up on the locking pawl by use of a linkage rod. The locking pawl has two jobs. The first is to lock the door. This is accomplished by blocking the locking cam on the door so that it can't rotate to unlock. The second job is to close the two piggyback lock sensing switches. These switches control power to all of the controls. If the door unlocks for any reason, these two switches will stop the machine. When the door handle is 1/4 to 1/2 of an inch from its fully closed position, the latching switch should close. The two piggyback lock sensing switches should be open when the door is unlocked and should be closed when the door is locked.

Adjustment

The latching switch and the piggyback lock sensing switches all have slotted mountings for easy adjustment.

1. Set door cam over pin.
2. Tighten spring screw on switch actuator arm until it just clears cam OD.
(Note: Spring screw will have approx. 1/8" thread exposed at end beyond nut.)
3. Set .040 thickness gage between arm and latch switch operator.
4. Swivel switch until it clicks closed. Back it up just until it clicks for a reset. Tighten in that position.
Check again for close and rest with gage in place. Remove gage.
5. Check for switch actuation at partial turn of cam as in operation above.
6. Check that lock arm swings by cam lobe to lock position when switch just clicks.

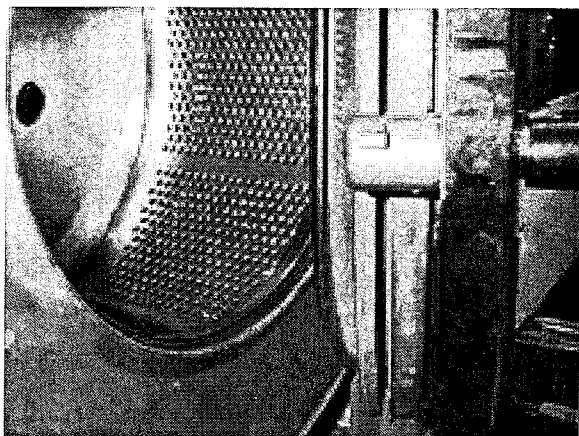

**PHOTO # 1 SHOWS THE
DOOR CAM AWAY FROM
DOOR LOCK ASSEMBLY**

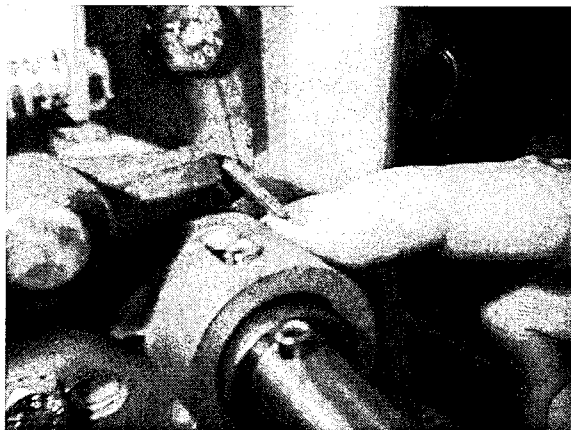

**PHOTO # 2
SHOWS WHERE YOU
WANT CLEARANCE**

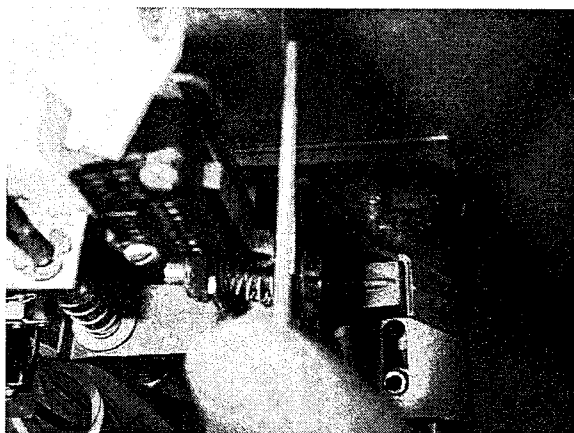

**PHOTO # 3 SHOWS
GAUGE IN PLACE
FOR ADJUSTMENT**

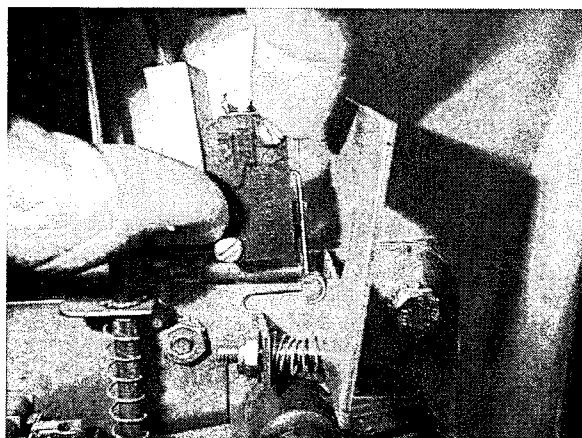

**PHOTO # 4
SHOWS SWITCH SWIVELLING
FOR ADJUSTMENT WITH GAUGE IN**

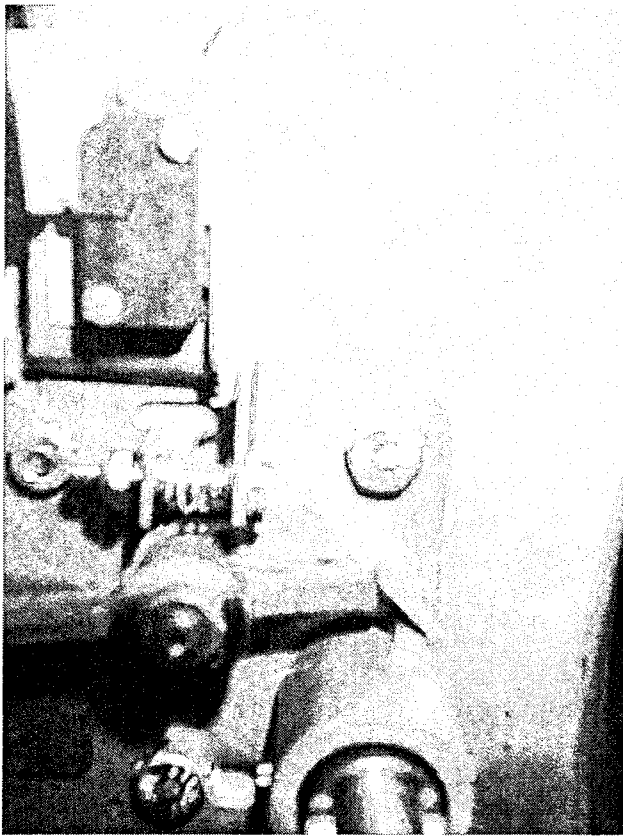

**PHOTO # 5 SHOWS AREA
WHERE CONTACT SHOULD BE MADE**

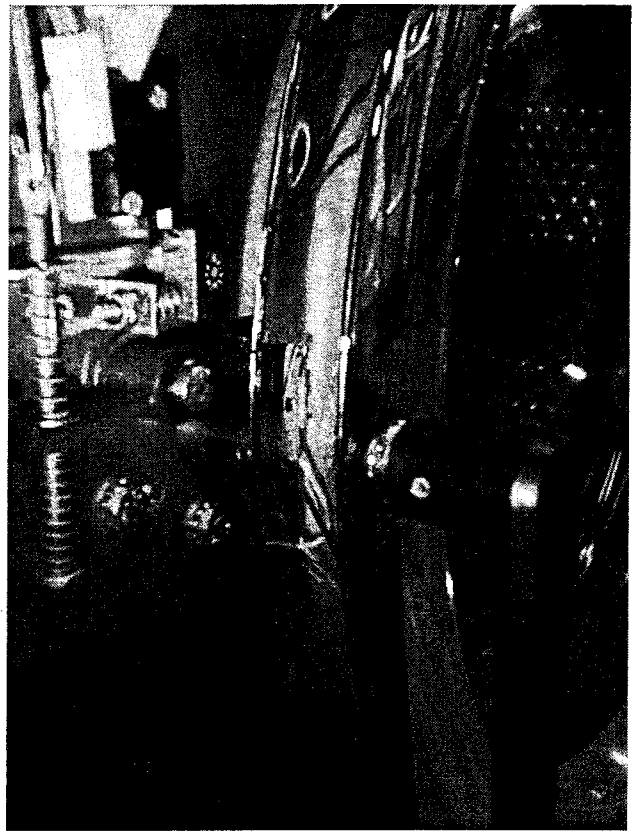

**PHOTO # 6
THE COMPLETE ASSEMBLY**

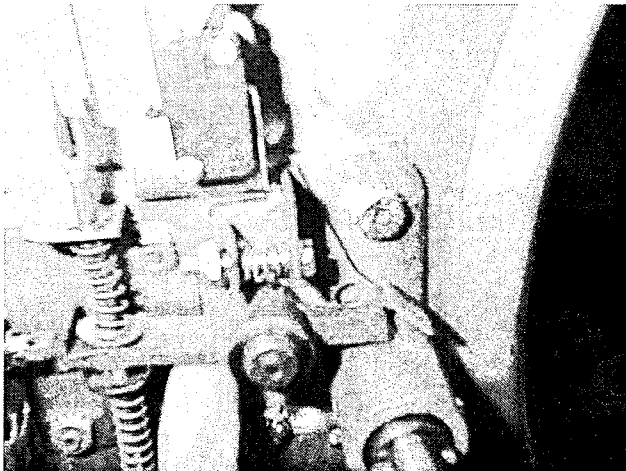

**PHOTO # 7
SHOWS LOCK ARM ENGAGED**

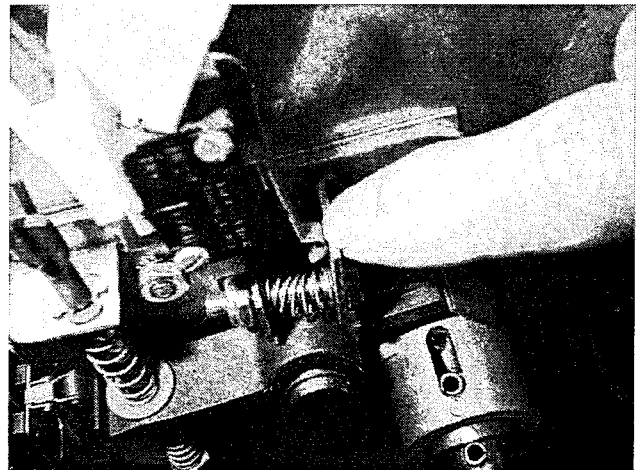

**PHOTO # 8
JUST TO SHOW WITHOUT
GAUGE IN PLACE**

Door Locking Solenoid

The door locking solenoid is powered shut with control voltage to lock the door and releases when voltage is removed. It is located in the left front corner of the washer.

Thermoactuators

The thermoactuators are a safety device that keeps the door from immediately unlocking if power is lost while the machine is operating. They are mounted under the door locking solenoid.

Lock Thermoactuator

Control voltage is applied to the lock thermoactuator at the beginning of the cycle making it extend and block the door locking solenoid. This keeps the door locked for approximately two minutes after a power failure occurs. The lock thermoactuator does not delay the door opening at the end of a normal cycle.

Unlock Thermoactuator

To insure that the lock thermoactuator has retracted by the end of the cycle, one minute prior to the end of the cycle, the unlock thermoactuator is powered with control voltage making it extend and unblock the door locking solenoid.

Loading Door Removal

- A. Support door to prevent dropping.
- B. Remove 3 bolts holding hinge retainer and set door off.

Loading Door Disassembly

- A. Remove the loading door as outlined above.
- B. Lay the door on a flat surface with the glass down.
- C. While holding down on the door glass, lift up on the door ring and roll back the lip of the gasket with your fingers.
- D. Work all the way around the gasket and the glass is out.

Loading Door Reassembly

- A. Lay the door ring face down on a flat surface.
- B. Start the glass into one side of the door gasket.
- C. Use one hand underneath to push the gasket out and the other hand on the top pulling the gasket in place.
- D. The front lip of the door gasket should be checked for proper seating.

Loading Door Adjustment

The door can be adjusted by changing the number of shims behind the door hinge and the door lock assembly. The vertical fit of the door to the tub can be altered by loosening the door hinge bolts and raising or lowering the door before retightening. It is important for the door to be centered on the tub front. By chalking the nose of the tub and closing the door to transfer that line to the gasket, the centering can be evaluated. It is also important for door pressure to be similar around the door perimeter. Door pressure can be evaluated by inserting a dollar bill in several positions and tugging on it. See Parts Section for kit to increase door sealing pressure.

Loading Door Hinge Removal

- A. First remove loading door, front panel, and trim ring.
- B. Remove 3 screws holding door hinge. Shims may be present between hinge and tub front. The number may be increased or decreased to adjust right side door pressure.

NOTE: Door hinge mounting bolts penetrate tub front and require silicone sealer applied to holes when reinstalling.

Back Panel Removal

- A. Remove all screws holding back panel in position except the bottom row.
- B. The bottom row of screws are slotted and only need to be loosened and the panel will lift off.

Note: The back panel is not only a safety requirement but also contributes to the rigidity of the cabinet, and must be reinstalled before operation.

Drive Belt Removal

Turn the drive belt off the basket pulley first and then remove from the motor pulley. Reverse this procedure for installation.

Drive Motor

Removal

- A. Remove the drive belt as explained above.
- B. Remove the tension spring and bracket.
- C. Disconnect the motor wires in the control area at the top of the machine. The motor wire retaining clamp should be removed and reused. There is a diagram showing where each motor wire plugs in so there is no need to mark them.
- D. Loosen the set screws on the motor support shaft.
- E. Remove the retaining bolt from the front of the support shaft.
- F. Remove the motor support shaft.
- G. Lift motor out of machine.

Control Panel Name Plate

The name plate on washer front is adhesive backed.

Removal

- A. The name plate may be removed by simply peeling it off.

Installation

- A. First remove the coin acceptor.
- B. Remove any remaining glue from the control panel.
- C. Before removing the paper backing from the name plate, check fit to the control panel. The program push buttons and the coin acceptor opening are the locating guides.
- D. Remove the paper backing from the right side of the name plate, position it on the panel and press right end into place, then peel the backing from the left end and press into place. Use a small non-metal roller for maximum adhesion and to make sure there are no air pockets or bubbles in the decal.

Tub Back, Bearing and Cylinder (basket) Assembly

Removal

- A. Remove the top and back panel as described previously.
- B. Move the rear channel, that the water valves mount to, forward by removing the five mounting screws.
- C. Remove the drive belt.
- D. Remove the overflow hose, tub fill hose and pressure switch hose from the back of the tub.
- E.. Mark the tub back and bearing assembly for ease in assembly later.
- F. Remove the 12 bolts and nuts from the perimeter of the tub back clamp ring. Two of the twelve bolts are longer and go through the thicker part of the brace where it connects to the frame.
- G. Remove the 2 bolts that fasten the clamp ring to the frame.
- H. The entire tub back and cylinder assembly may be lifted out of the tub (it may be necessary to break the adhesion of the silicone that seals the tub back to the tub). Blocks should be placed under the edges of the cylinder before setting it down to prevent damage to the cylinder flange.

Reassembly

Reverse the procedures above paying attention to the following areas

- A. Lay the washer on its front.

Note: Put a thick pad across the front of the washer, above the door, to protect the door handle and coin acceptor.

- B. Make sure the bearing housing weep holes are located at 12 o'clock and 6 o'clock.
- C. Clean the silicone rubber from the back of the outer tub and the perimeter of the tub back where the two meet. There is no gasket in this area.
- D. Apply a new bead of silicone rubber around the back of the outer tub.
- E. Lower the tub back, bearing and cylinder assembly into the washer outer tub.
- F. Torque all bolts according to the following chart.

Bolt Torque Chart

| <u>Bolt Size</u> | <u>Where Used</u> | <u>T-300 Torque</u> | <u>NUMBER BOLTS REQ.</u> |
|---------------------------|---|---------------------|--------------------------|
| 1/2" bolt 9545-017-009 | Tub End of Bearing Housing GRADE #5 | 70-110 ft/lbs | 6 |
| 1/2" bolt 9545-017-009 | Mounting of Tub to Cradle Assembly GRADE #5 | 70-110 ft/lbs | 4 |
| 3/8" bolt 9545-029-003 | Tub Back Ring to Tub Back GRADE#8 | 45-80 ft/lb | 12 |
| 3/8" bolt 9545-029-003 | Pulley End of Bearing Housing GRADE #8 | 45-80 ft/lbs | 6 |
| 3/8" bolt 9545-029-003 | Mounting ring ends (front) GRADE #8 | 20-30 ft/lbs | 1 |
| 9545-028-015 | Basket Pulley to Shaft(set screw) SQUARE HD. SET SCREW | 190-200 in/lbs | 2 |

Basket Pulley

The basket pulley is retained by a bolt, locking washer and a flat washer.

Removal

- A. Insert a large screw driver or punch through a hole in the pulley into the bearing housing support. This keeps the pulley from turning.
- B. Remove the retaining bolt, lockwasher and flat washer and reinstall just the bolt.
- C. Use a puller (Grip-O-Matic #1038 for T-300) to remove the pulley from the shaft shaft.

Reassembly

- A. Make sure that the tolerance ring is in place inside the pulley.
- B. The shoulder inside the pulley that holds the tolerance ring should face the back of the washer when installed correctly.
- C. Use a stack of flat washers and a longer bolt to press the pulley onto the basket shaft.
- D. Reinstall the retaining bolt, lock washer and flat washer. The shaft end bolt with washer should be installed with a torque of 190-200 in/lbs.

Bearing Housing, Water Seals and Tub Back

Removal From Basket Shaft

- A. Remove assembly from washer (see Tub Back, Bearing and Cylinder (basket) Assembly removal).
- B. Remove basket pulley (see Basket Pulley removal above).
- C. It is necessary to use a puller (Grip-O-Matic #1038 for T-300) to remove the

bearing housing assembly from the cylinder shaft. There is a flange on the bearing housing that should be used with this three armed puller.

Disassembly

- A. To remove the tub back assembly, the 6 bolts attaching it to the bearing housing must be removed.
- B. Remove water seals from the seal mounting plate on the cylinder shaft. These are removed with your fingers.

IMPORTANT- Be careful not to move the flat metal plate that mounts the two rubber sealing rings on the cylinder shaft. The location of this seal mounting plate is critical and it must not be moved. The two sealing rings can be replaced without disturbing it.

- C. The retaining ring next to the front bearing must also be removed.
- D. The bearings are pressed into the housing and must be pressed back out.

Reassembly

- A. When installing new bearings into a bearing housing, first press the front (large) bearing into the housing until it bottoms. With the bearing spacer in place, press the rear bearing in until the spacer is snug between the two bearings. Be sure and reinstall the retaining ring in front of the front bearing.
- B. The tub back assembly should be reattached to the bearing housing with the 6 mounting bolts and torqued according to the torque chart.

Note: The bead of silicone that seals each bolt to the tub back. This must be cleaned and replaced upon reassembly.

If the 6 support assemblies have been removed from the bearing housing, the 6 rear bearing housing bolts should be torqued according to the chart also.

- C. The primary and secondary seals that mount on the sealing ring may be slid over the shaft and seated on the metal sealing ring. In the unlikely event that the metal ring that mounts these sealing rings were to be damaged or moved, a new one would need to be pressed on. After installing the seals, lubricate the faces of the seals with silicone grease.

Reinstallation onto Basket Shaft

- A. Carefully set the assembly over the shaft engaging the bearings and bearing spacer.
- B. The tolerance ring that fits inside the pulley should be placed in position (see Basket Pulley Reassembly for correct positioning).
- C. The pulley should then be started onto the shaft. A stack of flat washers and a longer pulley bolt will be required to pull the basket shaft through the bearings and pulley.
- D. Install the shaft end bolt with washers and torque to 190-200 in/lbs
- E. See Tub Back, Bearing and Cylinder Assembly for installation of complete assembly back into washer.

Outer Tub

Removal

- A. The outer tub can easily be removed when the tub back, bearing and cylinder assembly have been removed as outlined above.
- B. At that point the only attachments to the chassis are the two front strap mounting bolts.

Reassembly

- A. Install outer tub in front strap leaving bolts loose.
- B. Install tub back assembly in washer (see reassembly of Tub Back, Bearing and Cylinder (basket) Assembly).
- C. With tub back assembly bolted to washer frame and to the back of the outer tub, tighten front strap bolts.

Removal of Cabinet

- A. The power supply, water hoses, and drain connection must all be disconnected before proceeding with the disassembly.
- B. Now remove the lower service panel and the top panel assembly.
- C. Remove the left and right lower front panel screws that retain the panel to the chassis.
- D. Remove the bottom row of back panel screws.
- E. Remove the loading door.
- F. Remove the screws along the bottom of each side panel. When reinstalling these screws do not overtighten.
- G. Remove clamp and soap dispenser hose where it attaches to the tub inlet.
- H. Disconnect the door lock wires from all switches and the door lock solenoid. The following illustration of their locations should be consulted.
- I. Disconnect pull rod between solenoid and door lock assembly.
- J. Disconnect the wires to the dump valve at the bottom of the machine.
- K. Disconnect the wires to the drive motor. There is a motor harness connector in the left rear corner of the control trough. The connector may be removed from the side of the trough by releasing the retainer ears. The wires from the trough components to the motor harness may be removed from the top side of the connector. There is a label on the trough floor to aid in reconnection of the wires to the connector.
- L. Remove the clamp and the hose from the vacuum breaker where it connects to the inlet on the back of the tub.
- M. Remove the pressure switch hose from the bottom of the switch.
- N. It should now be possible for two people to lift the cabinet up and off of the front of the machine and set it aside.

Section 5

Trouble Shooting

| Symptom | Probable Cause | Suggested Remedy |
|---|------------------------------------|--|
| Machine does not start | Power Supply | Check these areas: Circuit breakers, Voltage, Power leads, Power connections |
| | Door Switch | Check for continuity through door switch when door closed. If no continuity, adjust or replace door switch. |
| | Control Breaker | Check(1.5 amp on 3 phase) (7 amp on 1 phase) breaker for continuity. Replace breaker if no continuity. |
| | Control Transformer (3 phase only) | Check voltage output from control transformer for 120VAC. If voltage is incorrect, replace transformer. |
| | Coin Acceptor | Check coin switch to make sure coins trip switch and give continuity across switch when closed and resets as coin passes. If no continuity, adjust or replace switch. |
| | Accumulator Transformer | Check accumulator transformer for 12VAC output to accumulator. If no voltage, replace transformer. |
| | Coin Accumulator | Check accumulator to see that display is showing correct number of coins to start. Check accumulator for short 120VAC output signal at orange/white wire when preset number of coins is reached. If no display or output signal, replace coin accumulator. |
| | Timer | Check to insure that the timer is in the "off" position to supply 120VAC through the Start cam to the coin accumulator board. |
| Machine will not accept and count coins | Timer, Rapid Advance Motor | Check the rapid advance motor for continuity and replace if no continuity. |
| | Coin Acceptor | Check coin acceptor for any type of blockage or damage. Clean, adjust or replace the acceptor as necessary. |
| | Power Supply | Check these areas: Circuit breakers, Voltage, Power leads, Power connections |
| | Timer | Timer must be in off position, machine had to finish previous cycle to reset coin accumulator board. |
| | Coin Accumulator | Check accumulator to see that display is showing correct number of coins to start. If no display, replace coin accumulator. |

| Symptom | Probable Cause | Suggested Remedy |
|--|------------------------|--|
| Machine will not accept and count coins (continued) | Control Breaker | Check 1.5 amp(7 amp for 3 phase) breaker for continuity. Replace breaker if no continuity. |
| Door does not lock | Timer Position | The following sequence must have taken place to advance the timer before the door locks. -Loading door closed -Proper number of coins inserted to start machine -Accumulator counted and credited coins to advance timer into cycle closing on-off timer contact |
| | Door locking solenoid | Check to insure that solenoid is receiving 120VAC from S1 door switch. If it is, replace solenoid. |
| | Door Switch | Check for continuity through door latch switch(es) when door closed. If no continuity, adjust or replace door switch. |
| Door will not open | Thermoactuator | Check to see if thermoactuator(s) and/or its mechanism is stuck or binding and not allowing the door lock solenoid to open. Check to be sure that the locking thermoactuator is not receiving 120VAC during the last 1 1/2 minutes of the cycle. Also check to see that the unlocking thermoactuator is receiving 120VAC during the last minute of the cycle. If the thermoactuators do not receive voltage at the correct times, change the timer. If the timing and voltage are correct, replace the thermoactuator. |
| | Door Rod | Check to see that door rod from solenoid to lock ass y is long enough to allow lock ass y to disengage. If not, adjust rod. |
| | Door Lock Solenoid | Check that door lock solenoid is not stuck closed. If stuck, replace solenoid. |
| | Timer | Make sure machine is in off position allowing timer to authorize door unlock. |
| Machine starts but timer will not advance | Main Timer Drive Motor | If 120VAC is supplied to timer motor, but it doesn't operate, replace timer motor. |

| Symptom | Probable Cause | Suggested Remedy |
|--------------------------------------|-----------------------------------|---|
| Hot water does not enter tub in wash | Water Valve Coil | Check coil continuity at terminals and replace if no continuity. |
| | Water Inlet Screens | Check water inlet screens for blockage and clean if necessary. |
| | Water | Check to insure that water is turned on and operating. |
| | Timer | Advance machine into wash cycle and check for 120VAC at red/blue wire coming from timer. |
| | Water Temperature Selector Switch | Check switch for continuity between red/blue wire and red/yellow wire when Hot is selected. If no continuity, change switch. |
| No cold water to tub in wash | Pressure Switch | Check pressure switch continuity between terminals #1 & #2. If no continuity, check pressure switch hose for obstruction. If hose okay, change pressure switch. |
| | Water Valve Coil | Check coil continuity at terminals and replace if no continuity. |
| | Water Inlet Screens | Check water inlet screens for blockage and clean if necessary. |
| | Water | Check to insure that water is turned on and operating. |
| | Pressure Switch | Check pressure switch continuity between terminals #1 & #2. If no continuity, check pressure switch hose for obstruction. If hose okay, change pressure switch. |
| No hot water in detergent dispenser | Timer | Choose cold cycle, advance to wash, check for voltage on white/black from timer. If no voltage, replace timer. |
| | Water Temperature Selector Switch | Choose cold cycle, advance to wash and check wht/org wire from selector switch for 120VAC. If no voltage, change switch. |
| | Water Valve Coil | Check coil continuity at terminals and replace if no continuity. |
| No hot water in detergent dispenser | Water Inlet Screens | Check water inlet screens for blockage and clean if necessary. |
| | Water | Check to insure that water is turned on and operating. |

| Symptom | Probable Cause | Suggested Remedy |
|--|-------------------------------------|--|
| No hot water detergent dispenser (continued) | Timer | Advance to wash, check for voltage on red/org in from timer. If no voltage, replace timer. |
| Water does not flush softener compartment. | Water Valve Coil | Check coil continuity at terminals and replace if no continuity. |
| | Water Inlet Screens | Check water inlet screens for blockage and clean if necessary. |
| | Water | Check to insure that water is turned on and operating. |
| | Pressure Switch | Check pressure switch continuity between terminals #1 & #2. If no continuity, check pressure switch hose for obstruction. If hose okay, change pressure switch. |
| | Timer | Advance machine to final rinse and check for voltage at wht/blue wire coming from timer. If no voltage, replace timer. |
| Water comes in but level does not rise | Drain Valve (open) | Check these areas - Drain valve blockage - Drain valve motor and gear train. If power but drain valve does not close, replace valve. - Power to the drain valve. If no power to drain valve, check (brn/yel) circuit for power. |
| Water level too high | Pressure Switch | Check for blockage in pressure switch hose. Check for pressure switch opening circuit across terminals #1 & #2. Replace switch if contacts do not open. |
| Water drains slowly | Drain System | Check hoses and drain valve for blockage. Clean if necessary. Check building drains for blockage or inadequate size. |
| Machine does not tumble | R2 Spin Relay | Check continuity between terminals #13 & #14 on R2 relay. |
| | Wash Speed Capacitor (1 phase only) | Check capacitor and replace if failed. |

| Symptom | Probable Cause | Suggested Remedy |
|--|-------------------------------------|--|
| Machine tumbles in only one direction | Reversing Timer | Check to see that reversing timer is running. Check for alternating 120VAC at orange/green and at brown/white from reversing timer to signal reversing operation to wash relays. If not running or no voltage, replace reversing timer. |
| | Tumble Relays | Check R1A and R1B tumble speed relays. If one does not close during tumble speed, check coil continuity and power to the relay. If 120VAC to relay and no coil continuity, replace relay. |
| Machine does not spin | Spin Relay | Check spin relay coil for continuity, replace if no coil continuity. Check relay contacts, replace if no continuity. |
| | Pressure Switch | Check pressure switch for continuity across terminals #1 & #2 indicating pressure switch has reset to the empty position. If no continuity, change pressure switch. |
| | Spin Start Capacitor (1 phase only) | Check capacitor and replace if failed. |
| | Motor Overload | Check vio/wht wire at terminal strip and vio wire at spin relay for continuity. If open, replacement motor must be considered. |
| Machine starts and advances through cycle but motor does not operate | Reversing Timer | Check to see that reversing timer is running. Check for alternating 120VAC at orange/green and at brown/white from reversing timer (3 ph.) [1phase-120vac Blk/orange and Blk/white] to signal reversing operation to wash relays. If not running or no voltage, replace reversing timer. |
| Machine does not stop at end of cycle | Coin accumulator | Check for continuous output from terminal where orange-white wire connects to accumulator. If so replace accumulator. |
| Water leakage around loading door | Door Adjustment | Door may need adjustment due to abuse or wear. Check tightness around perimeter using a dollar bill. Adjust left to right tightness by shims at door lock or hinge side. It is important to center gasket to tub opening before tightening door to hinge bolts. Chalk may be used on tub front to show point of contact with tub. If gasket is deformed, worn, or damaged, replace. Refer to parts section for door gasket expander kit. |

| Symptom | Probable Cause | Suggested Remedy |
|---------------------|-----------------|---|
| Excessive vibration | Mounting System | Check these areas: - Strength of mounting structure, concrete or base. - Mounting bolts may be loose and need tightening. |
| | Drive Belt | Worn drive belt can cause vibration and noise. |
| | Loading | NOTE: SMALL LOADS CONTRIBUTE TO OUT OF BALANCE LOADING AND INCREASE VIBRATION. |

Section 6

Parts Data

Thoroughbred 300

Accessories

| | | | | | |
|---------------|----------------|----------------|--------------|--------------|---------------------|
| Models | WCN18AA | 120 | volts | 60hz. | Single Phase |
| | WCN18AB | 208-240 | volts | 60hz. | Three Phase |

| Part Number | Description | MODELS | |
|--------------------|---|------------|------------|
| | | WCN18 A | WCN18 B |
| 9990-027-011 | Hose, Water Supply (furnished) 3/8" I.D. x 48" | 2 | 2 |
| 9990-027-013 | Hose, Water Supply (optional) 5/8" I.D. x 48" | | |
| 8641-242-000 | Washer, Inlet Hose (furnished) | 2 | 2 |
| 9565-003-001 | Strainer, Inlet Hose (furnished) | 2 | 2 |
| 9242-417-001 | Drain hose 10 ft. length x 2-1/4" I.D. | | |
| 9242-417-003 | Drain hose 10ft. length x 3" I.D. | | |
| 8641-586-002 | Bevel Washer for 5/8" bolt used in installations using angle iron bases | | |
| 8641-586-003 | Bevel Washer for 3/4" bolt used in installations using angle iron bases | | |
| 9732-139-001 | Kit , Door Gasket Expander (large) | | |
| 9732-139-002 | Kit , Door Gasket Expander (small) | | |
| 9732-140-001 | Manual Operation Kit | | |
| 9539-474-001 | Switch, Blk/Red (included in kit) | | |
| 9539-474-002 | Switch, Blk/Wht (included in kit) | | |
| 8545-055-002 | Electrical Probe 100-600VAC | | |
| 8545-055-001 | Electrical Probe 24-90 VAC | | |
| 8538-151-001 | Sealing compound | | |
| 8545-051-002 | TORX#20 | | |
| 8545-051-003 | Special Tool For Removing Coin Acceptor Mounting Screws. (T-10 Torx) | | |
| Grip-O-Matic #1038 | Puller to Remove Pulley and Bearing Housing from Shaft on T-300 | | |

CABINET AND FRONT PANEL GROUP

| Key | Part Number | Description | MODELS | |
|-----|--------------|---|--------|---|
| | | | WCN18 | |
| | | | A | A |
| | | | A | B |
| 1 | 9454-635-006 | Panel, Side (Left) - Stainless | 1 | 1 |
| 2 | 9454-635-005 | Panel, Side (Right) - Stainless | 1 | 1 |
| 3 | 9545-018-018 | Screw, (Side Panel to Base) | 6 | 6 |
| * | 8640-414-006 | Nut, Hex | 6 | 6 |
| * | 9029-066-001 | Bracket, Side Panel | 1 | 1 |
| * | 8640-413-002 | Nut, Hex | 2 | 2 |
| * | 9545-008-026 | Screw | 2 | 2 |
| 4 | 9454-668-001 | Panel Assy, Front | 1 | 1 |
| * | 9059-063-004 | Band, Edge Protector | 1 | 1 |
| * | 8640-399-008 | Nut, Spring (Attaches Top of Panel) | 3 | 3 |
| * | 9545-008-026 | Screw, Hex (Attaches Top of Panel) | 5 | 5 |
| 5 | 9545-008-014 | Screw, Flat Head | 2 | 2 |
| 5 | 8641-585-001 | Washer, Finish | 2 | 2 |
| * | 8640-399-008 | Nut, Spring-To Front Panel | 2 | 2 |
| * | 9545-008-023 | Screw, Guide | 2 | 2 |
| 6 | 8502-624-002 | Label, Door Opening | 1 | 1 |
| 7 | 9989-451-001 | Panel, Control (Mounts Nameplate) | 1 | 1 |
| * | 9545-008-026 | Screw, Control Panel Mtg | 4 | 4 |
| 8 | 9412-074-003 | Nameplate, Control Panel T-300 | 1 | 1 |
| 9 | 9454-662-001 | Panel, Top | 1 | 1 |
| 10 | 8650-012-003 | Lock, Top (w/Key) | 1 | 1 |
| * | 9306-025-001 | Key, Top-6324 | 1 | 1 |
| * | 9095-038-001 | Cam, Lock-Top | 1 | 1 |
| * | 8640-426-001 | Nut, 9/32 | 1 | 1 |
| * | 8641-581-008 | Washer | 1 | 1 |
| 11 | 9108-096-001 | Door, Lower Service | 1 | 1 |
| 12 | 9244-081-001 | Handle (bumper guard) | 1 | 1 |
| * | 9545-045-010 | Screw | 4 | 4 |
| 13 | 9545-008-014 | Screw Mtg., Flat Head | 2 | 2 |
| 13 | 8641-585-001 | Washer, Finish | 2 | 2 |
| * | 9545-008-023 | Screw, Guide | 2 | 2 |
| 14 | 9108-095-003 | Door, Dispenser | 1 | 1 |
| * | 9451-191-001 | Pin, Plain ss | 2 | 2 |
| 15 | 9467-025-001 | Post, Door Mounting | 2 | 2 |
| * | 9545-045-002 | Screw, Dispenser Post Mtg | 4 | 4 |
| * | 9545-008-012 | Screw, Dispenser Mounting | 4 | 4 |
| * | 8640-399-007 | Nuts, Spring | 4 | 4 |
| * | 9086-017-001 | Catch, Top Panel | 2 | 2 |
| * | 9467-024-001 | Post, Top Locator | 2 | 2 |
| * | 8640-411-003 | Nut, Keps | 2 | 2 |
| * | 9355-001-001 | Locator, Panel | 2 | 2 |
| * | 9545-008-025 | Screw,#10 | 2 | 2 |
| 16 | 9021-001-010 | Acceptor, Coin (25c) | 1 | 1 |
| 17 | 9732-122-001 | Box Ass'y Coin(see coin box group) | 1 | 1 |

* Not Illustrated

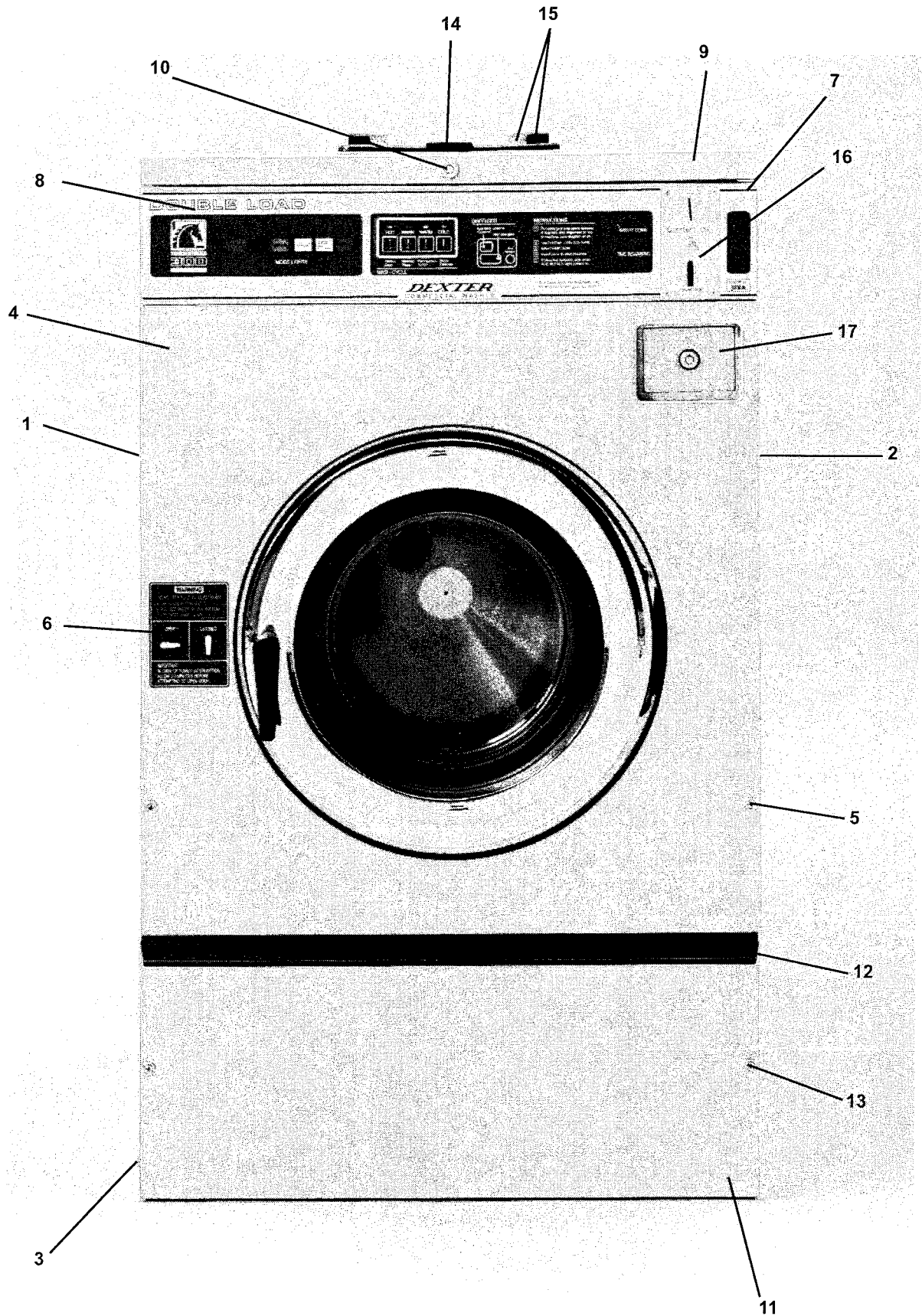

REAR VIEW

| Key | Part Number | Description | MODELS | |
|-----|--------------|--|--------|----|
| | | | WCN18 | |
| | | | A | A |
| | | | A | B |
| 1 | 9732-127-009 | Drive Motor, 1 Phase | 1 | |
| 1 | 9732-127-010 | Drive Motor, 3 Phase | | 1 |
| 2 | 9497-222-002 | Rod, Motor Mtg | 1 | 1 |
| 3 | 9545-029-005 | Screw (end of motor rod) | 1 | 1 |
| 3 | 8641-582-014 | Lockwasher (end of motor rod) | 1 | 1 |
| 3 | 9076-052-002 | Collar, Shaft (w/set screws) | 3 | 3 |
| * | 9053-074-001 | Bushing, Motor Hangar | 2 | 2 |
| 4 | 9453-169-006 | Pulley, Motor | 1 | 1 |
| * | 9545-028-015 | Set Screw, Sq. Hd. | 2 | 2 |
| 5 | 9908-041-002 | Pulley, Driven | 1 | 1 |
| 6 | 9545-017-009 | Screw | 1 | 1 |
| 6 | 8641-581-026 | Washer, Flat | 1 | 1 |
| 6 | 8641-582-016 | Lockwasher | 1 | 1 |
| 7 | 9040-076-004 | Drive Belt | 1 | 1 |
| 8 | 9081-099-001 | Channel, Rear | 1 | 1 |
| * | 9545-008-026 | Screw | 4 | 4 |
| * | 8640-399-004 | Nut, Spring | 4 | 4 |
| 9 | 9242-463-001 | Hose, Overflow 9" | 1 | 1 |
| 10 | 9242-449-002 | Hose, Overflow | 1 | 1 |
| * | 8654-029-000 | Clamp, Hose | 2 | 2 |
| 11 | 9122-005-004 | Dispenser--(washcompound) | 1 | 1 |
| 12 | 9206-416-001 | Gasket, Dispenser | 1 | 1 |
| * | 9454-632-001 | Panel Assy., Back | 1 | 1 |
| * | 9545-008-026 | Screw | 10 | 10 |
| * | 8640-399-004 | Nut, Spring | 10 | 10 |
| * | 9242-175-000 | Hose, Pressure Switch | 1 | 1 |
| * | 8654-117-015 | Clamp, Pressure Sw. Hose | 1 | 1 |
| 13 | 5198-211-004 | Circuit Breaker, 1.5 amp (3-phase) | 1 | 1 |
| * | 5198-211-002 | Circuit Breaker, 7 amp (1-phase) | | 1 |
| 14 | 9029-027-003 | Strap, Motor Tension | 1 | 1 |
| 15 | 8640-413-002 | Nut, Strap to Motor | 1 | 1 |
| 15 | 8641-581-008 | Washer | 1 | 1 |
| 16 | 9534-319-002 | Spring, Belt Tension | 1 | 1 |
| 17 | 9545-055-001 | Bolt, Eye 1/4-20x2 1/2" | 1 | 1 |
| 18 | 8640-414-003 | Nut, 1/4 Elastic Stop | 1 | 1 |
| 19 | 9545-029-003 | Screw, 3/8"x 1 1/2" | 12 | 12 |
| * | 8640-415-004 | Nut, Flange Lock | 12 | 12 |
| * | 9552-038-003 | Shim | AR | AR |
| * | 9456-041-007 | PLASTIC PLUG(inside cylinder) | 1 | 1 |
| * | 9454-632-001 | Back Panel | 1 | 1 |

* Not Illustrated

Rear View

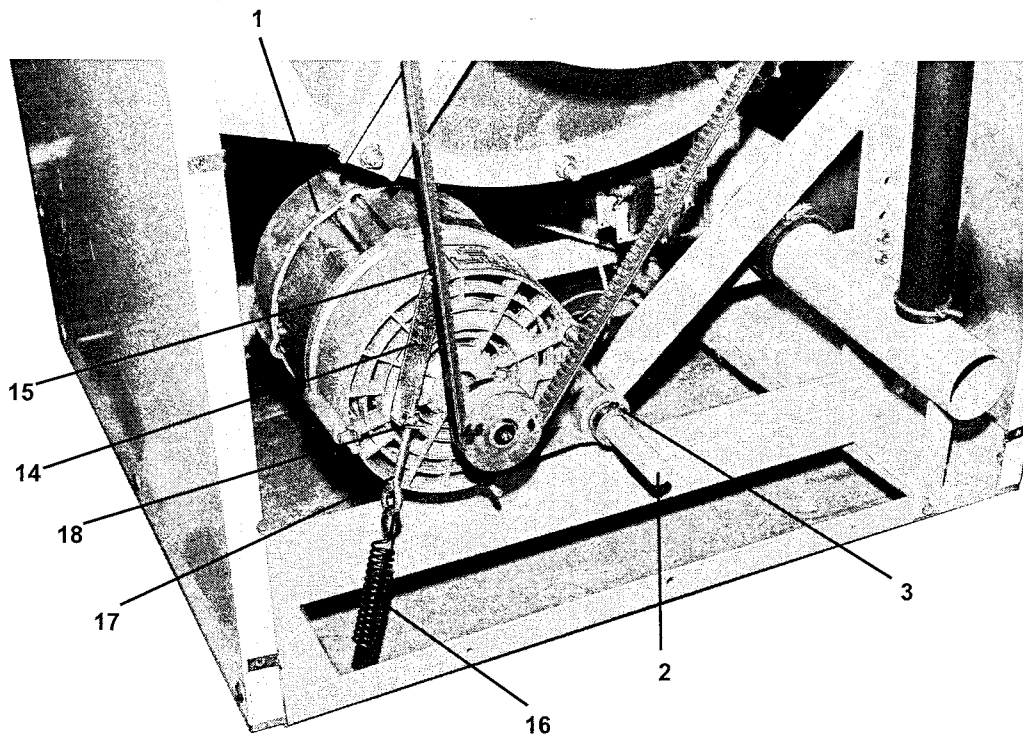
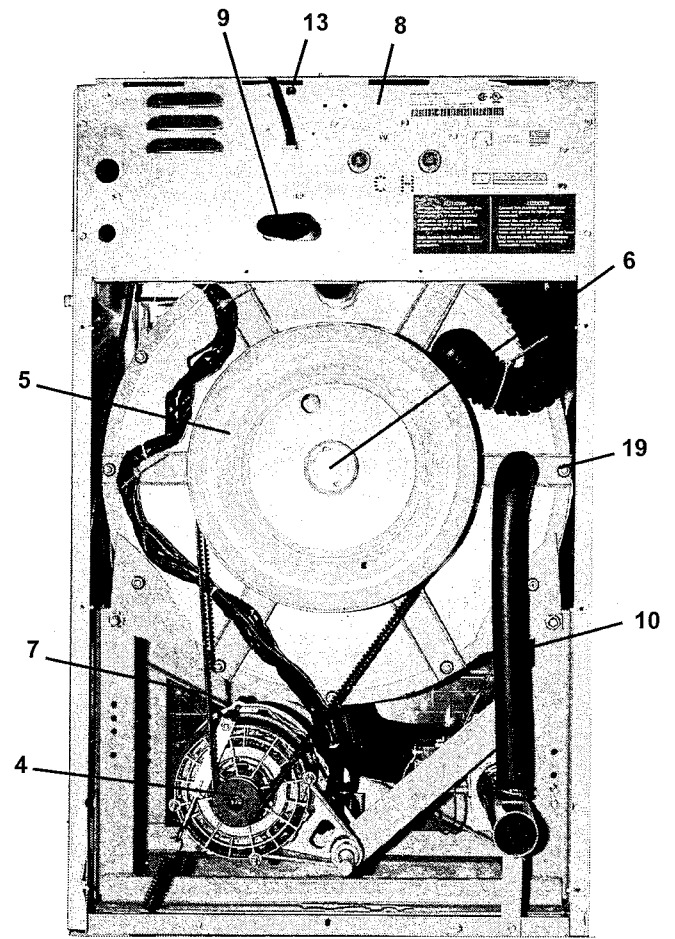
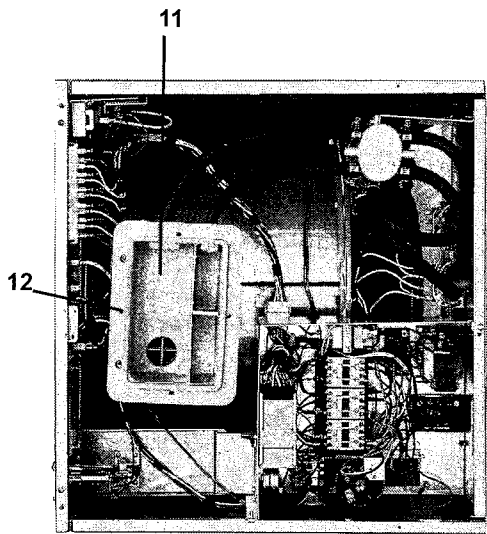

CHASSIS AND DRAIN GROUP

| Key | Part Number | Description | MODELS | |
|-----|--------------|---|--------|----|
| | | | WCN18 | |
| | | | A | A |
| | | | A | B |
| 1 | 9945-093-002 | Base Assy, Frame | 1 | 1 |
| 2 | 9930-135-001 | Tub Assy | 1 | 1 |
| 3 | 9950-045-002 | Ring Assy, Tub Mtg-Front | 1 | 1 |
| 4 | 9545-017-012 | Bolt, Top Front Ring 1/2" x 3" | 1 | 1 |
| 4 | 8641-582-016 | Lockwasher | 1 | 1 |
| 4 | 8640-417-002 | Nut | 1 | 1 |
| 6 | 9545-017-009 | Screw, Front & Rear Rings to Base 1/2" x 1 1/4" | 4 | 4 |
| 6 | 8641-582-016 | Lockwasher | 4 | 4 |
| 6 | 8640-417-002 | Nut | 4 | 4 |
| 7 | 9379-177-006 | Valve, Drain (2 1/4" ball type) | 1 | 1 |
| 8 | 9029-005-001 | Bracket, Drain Valve | 1 | 1 |
| * | 9545-030-002 | Screw, Valve to Bracket | 1 | 1 |
| * | 8641-581-018 | Washer | 1 | 1 |
| 9 | 9545-030-002 | Screw, Bracket to Base | 2 | 2 |
| 10 | 9915-116-004 | Tube Assy, Drain | 1 | 1 |
| * | 9545-030-002 | Screw, Tube Mtg | 2 | 2 |
| 11 | 9242-455-001 | Hose, Tub to Drain Valve | 1 | 1 |
| 12 | 9242-451-002 | Hose, Drain Valve to Outlet | 1 | 1 |
| * | 8654-117-014 | Clamp, Hose | 3 | 3 |
| 13 | 9732-127-009 | Motor, Drive (1 PH) | 1 | |
| 13 | 9732-127-010 | Motor, Drive (3 PH) | | 1 |
| 14 | 9497-222-002 | Rod, Motor Mtg | 1 | 1 |
| 15 | 9076-052-002 | Collar, Shaft | 2 | 2 |
| 16 | 9545-029-005 | Screw, Motor Mtg Rod | 1 | 1 |
| 16 | 8641-582-014 | Lockwasher | 1 | 1 |
| 17 | 9453-169-006 | Pulley, Motor | 1 | 1 |
| * | 9545-028-015 | Set Screw, Sq. Hd | 2 | 2 |
| 18 | 9040-076-004 | Belt, Drive | 1 | 1 |
| * | 9552-038-003 | Shim, Support Assembly | AR | AR |
| 19 | 9242-458-001 | Vacuum Breaker to Tub | | |
| 24 | 9242-450-002 | Hose, Dispenser to Tub | 1 | 1 |
| * | 8654-117-008 | Clamp, Dispenser Hose | 2 | 2 |

* Not Illustrated

Chassis and Drain Group

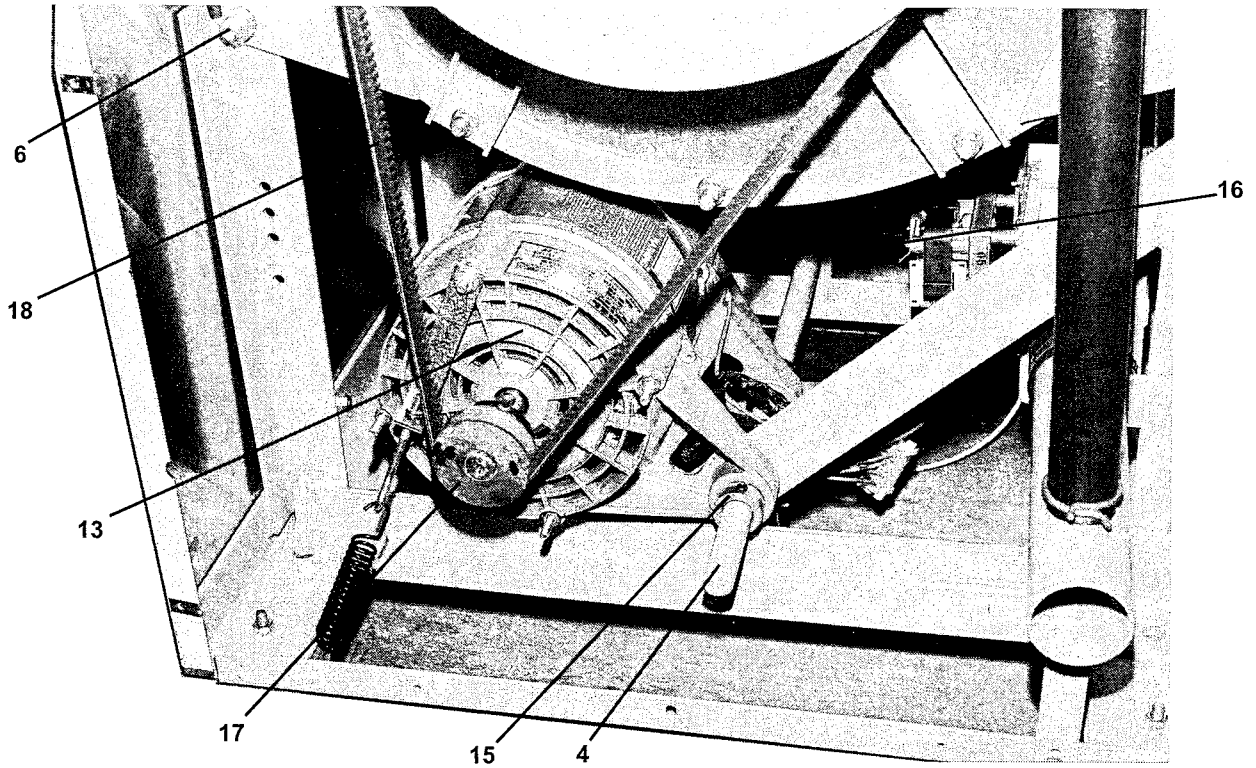
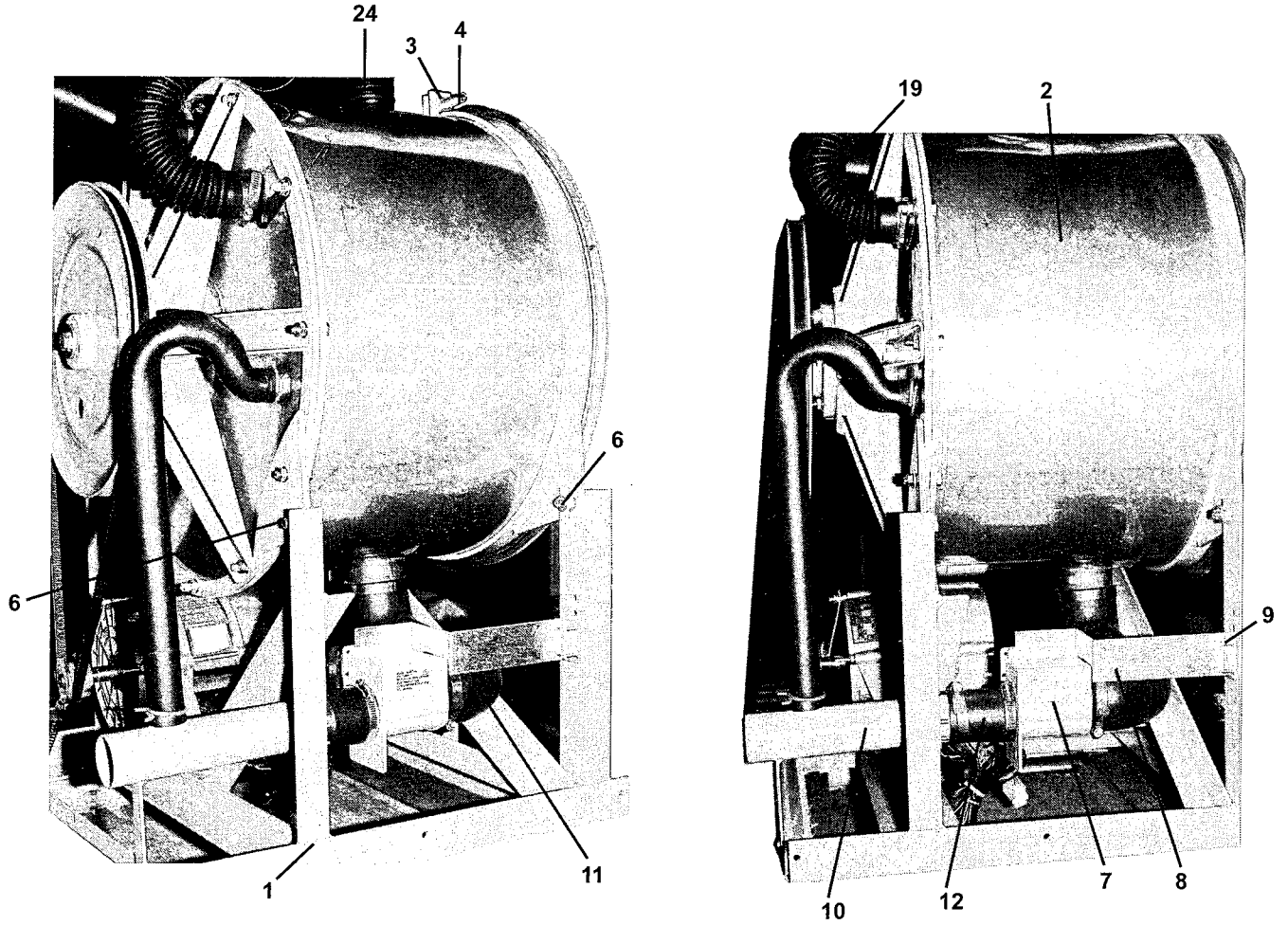

BEARING HOUSING AND PULLEY GROUP

| Key | Part Number | Description | MODELS | |
|-----|--------------|---|--------|---|
| | | | WCN18 | |
| | | | A | A |
| | | | A | B |
| * | 9848-111-001 | Cylinder, Assy | 1 | 1 |
| * | 9803-182-001 | Housing, Bearing- Assembly (includes items #2-#6) | 1 | 1 |
| 2 | 9241-174-002 | Housing, Bearing | 1 | 1 |
| 3 | 9036-159-001 | Bearing, Front | 1 | 1 |
| 4 | 9036-159-003 | Bearing, Rear | 1 | 1 |
| 5 | 9538-161-001 | Spacer, Bearing | 1 | 1 |
| 6 | 9487-238-002 | Ring, Bearing Retainer | 1 | 1 |
| 7 | 9532-140-005 | Seal, Secondary | 1 | 1 |
| 8 | 9532-140-004 | Seal, Primary | 1 | 1 |
| 9 | 9950-047-001 | Ring, Seal Mtg | 1 | 1 |
| 9a | 9732-137-001 | Ring, Seal Ass'y Tub Back before serial number #425580 | 1 | 1 |
| * | 9487-261-001 | New Style Ring Ass'y Tub Back after serial number# 425580 | 1 | 1 |
| 10 | | Back Assy, Tub | 1 | 1 |
| 11 | 9545-017-009 | Screw, 1/2 x 1 1/4 Grade 5 | 6 | 6 |
| 11 | 8640-417-002 | Nut | 6 | 6 |
| 11 | 8641-582-016 | Lockwasher | 6 | 6 |
| 12 | 9991-049-002 | Support Assy., Bearing Housing | 6 | 6 |
| 13 | 9545-029-003 | Screw, 3/8 x 1 1/2 Grade 8 | 6 | 6 |
| 13 | 8640-415-004 | Nut | 6 | 6 |
| 14 | 9908-041-002 | Pulley, Driven | 1 | 1 |
| 15 | 9487-234-002 | Ring, Tolerance | 1 | 1 |
| 16 | 8641-581-026 | Washer | 1 | 1 |
| 16 | 9545-017-009 | Screw | 1 | 1 |
| 16 | 8641-582-016 | Lockwasher | 1 | 1 |
| 17 | 9950-046-002 | Ring ass'y Tub Mtg. rear | 1 | 1 |
| 18 | 9962-009-003 | Tub Back Only before serial number # 425580 | 1 | 1 |
| * | 9962-012-001 | Tub Back Only after serial number #425580 | 1 | 1 |

* Not Illustrated

Bearing Housing & Pulley Group

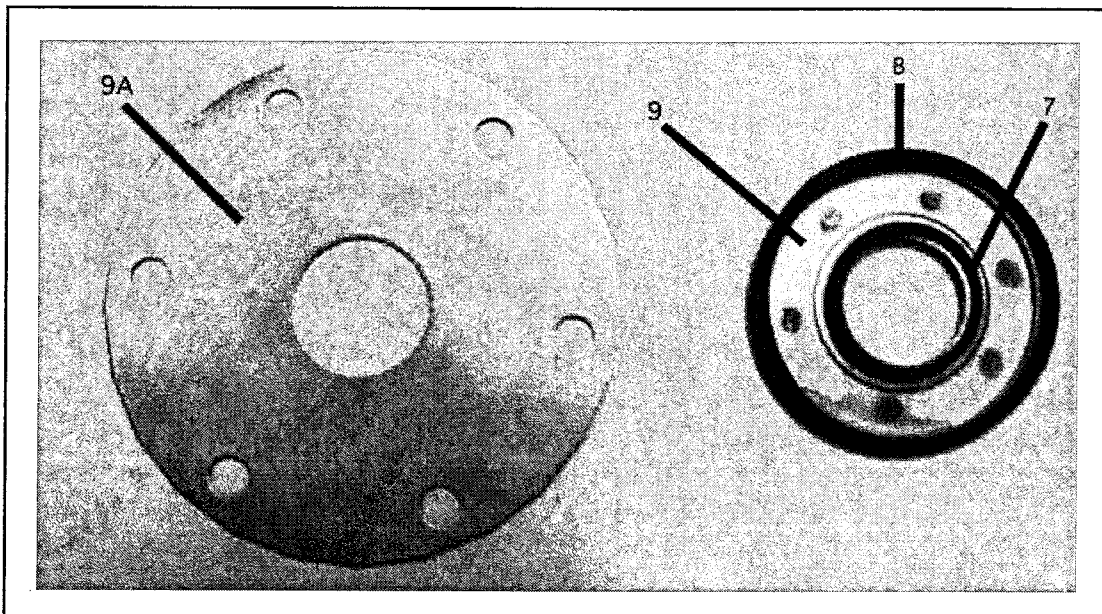

Bearing Housing and Pulley Group

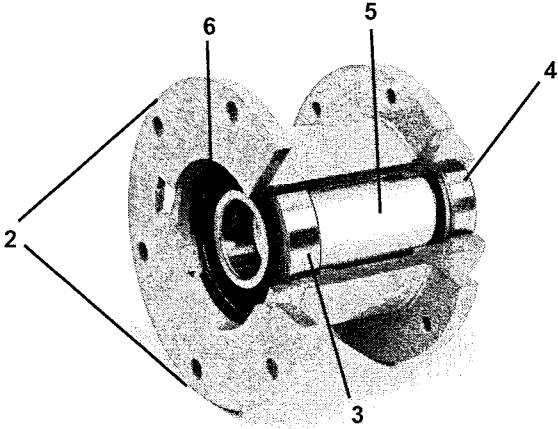
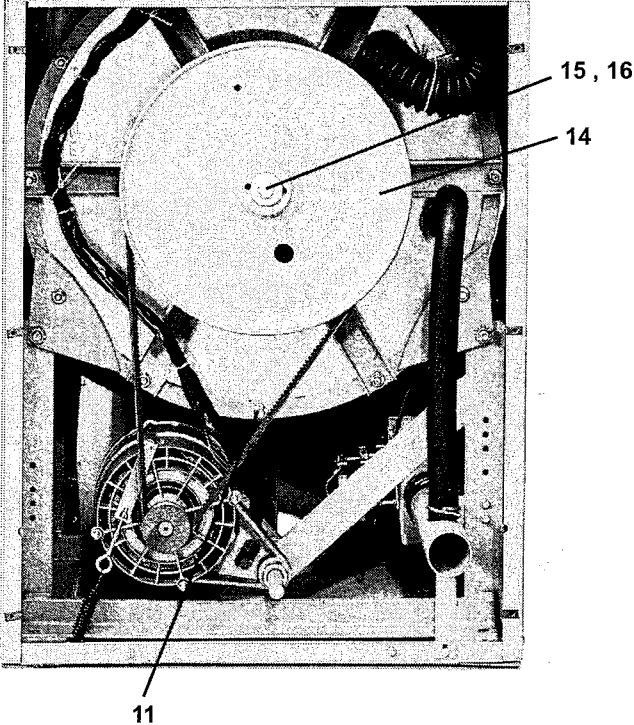
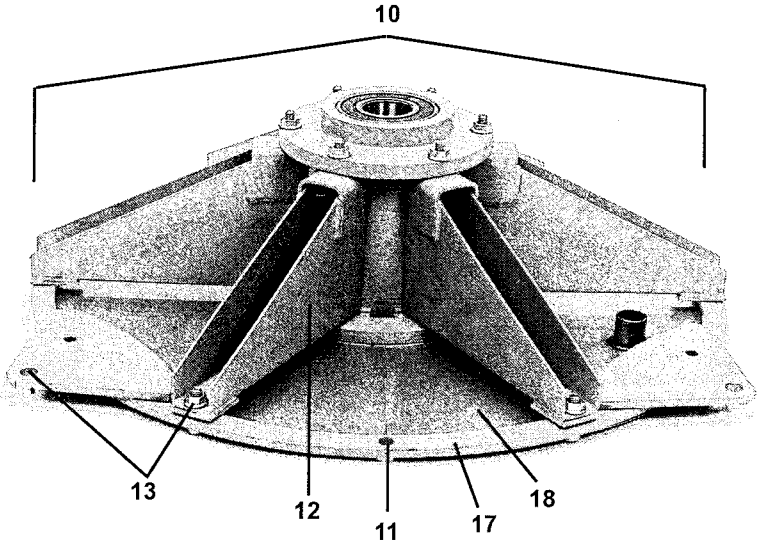

DOOR LOCK GROUP

| Key | Part Number | Description | MODELS | |
|-----|--------------|---|--------|----|
| | | | WCN18 | |
| | | | A | A |
| | | | A | B |
| * | 9885-023-001 | Lock Assy, Complete (includes #1 thru #23)..... | 1 | 1 |
| 1 | 9982-284-001 | Plate Assy, Door Lock | 1 | 1 |
| 2 | 8641-581-030 | Washer, Flat | 1 | 1 |
| 3 | 9008-005-001 | Actuator, Latching Switch | 1 | 1 |
| 4 | 9450-002-002 | Pawl, Locking | 1 | 1 |
| 5 | 8641-569-003 | Washer, Spring | 1 | 1 |
| 6 | 9487-200-004 | Ring, Retaining | 1 | 1 |
| 8 | 9029-035-001 | Bracket, Switch | 1 | 1 |
| 9 | 8640-413-002 | Nut, Hex | 2 | 2 |
| 10 | 9534-364-002 | Spring, Actuating | 1 | 1 |
| 11 | 9545-012-020 | Screw, Hx. | 1 | 1 |
| 12 | 8640-413-004 | Nut, Elastic Stop | 2 | 2 |
| 13 | 9534-364-001 | Spring, Return | 2 | 2 |
| 14 | 9451-193-001 | Pin, Guide | 1 | 1 |
| 15 | 9487-200-005 | Ring, Retaining | 1 | 1 |
| 16 | 8641-581-031 | Washer | 2 | 2 |
| 17 | 9539-461-008 | Switch, Latching Sensing | 1 | 1 |
| 18 | 9550-169-003 | Shield, Switch | 3 | 3 |
| 19 | 9545-020-001 | Screw | 2 | 2 |
| 20 | 8640-401-001 | Nut, Twin | 2 | 2 |
| 21 | 9539-461-007 | Switch, Locking Sensing | 2 | 2 |
| 22 | 9008-006-002 | Actuator, Switch | 1 | 1 |
| 23 | 9545-020-003 | Screw | 2 | 2 |
| 23 | 8640-401-001 | Nut, Twin | 1 | 1 |
| 23a | 9451-181-004 | Pin ,Dowel..... | 1 | 1 |
| * | 9552-037-001 | Shim, Door Lock, Thin | AR | AR |
| * | 9552-037-002 | Shim, Door Lock, Thick | AR | AR |
| * | 9545-018-014 | Screw, Lock mtg 1/4-20x3/4 | 3 | 3 |
| * | 8641-582-007 | Lockwasher | 3 | 3 |
| 36 | 9922-011-001 | Solenoid Ass'y Door Locking(includes 24 thru 34) | 1 | 1 |
| 24 | 9029-073-001 | Bracket, Solenoid | 1 | 1 |
| 24a | 9985-169-001 | Bracket ass'y Solenoid Slide | 1 | 1 |
| 25 | 9536-074-001 | Solenoid | 1 | 1 |
| 26 | 9545-008-001 | Screw, Solenoid Mtg | 4 | 4 |
| 27 | 9540-033-002 | Stop, Door Lock Solenoid | 1 | 1 |
| 28 | 9545-061-001 | Screw, Shoulder | 1 | 1 |
| 29 | 9586-001-001 | Thermoactuator | 2 | 2 |
| 30 | 9545-031-005 | Screw | 2 | 2 |
| 31 | 9538-157-004 | Spacer, Plastic | 1 | 1 |
| 32 | 9538-166-004 | Spacer, Metal | 1 | 1 |
| 33a | 9545-010-001 | Screw, Cross Recessed | 1 | 1 |
| * | 8640-412-005 | Nut, Keps #8 | 1 | 1 |
| * | 8640-411-003 | Nut, Keps #6 | 2 | 2 |
| * | 8640-413-002 | Nut, Sol. Brkt. to Control Panel | 3 | 3 |
| 35 | 9497-225-004 | Rod, Pull | 1 | 1 |

* Not Illustrated

Door Lock Group

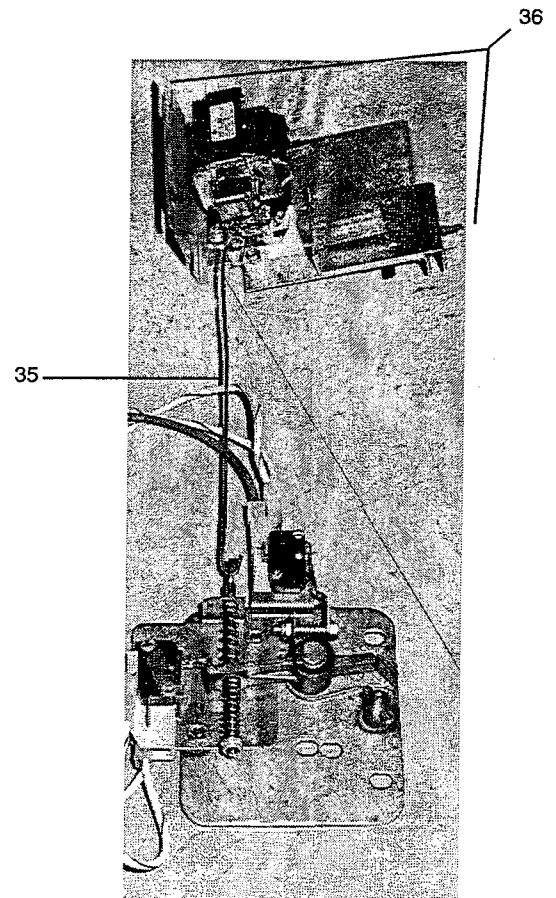
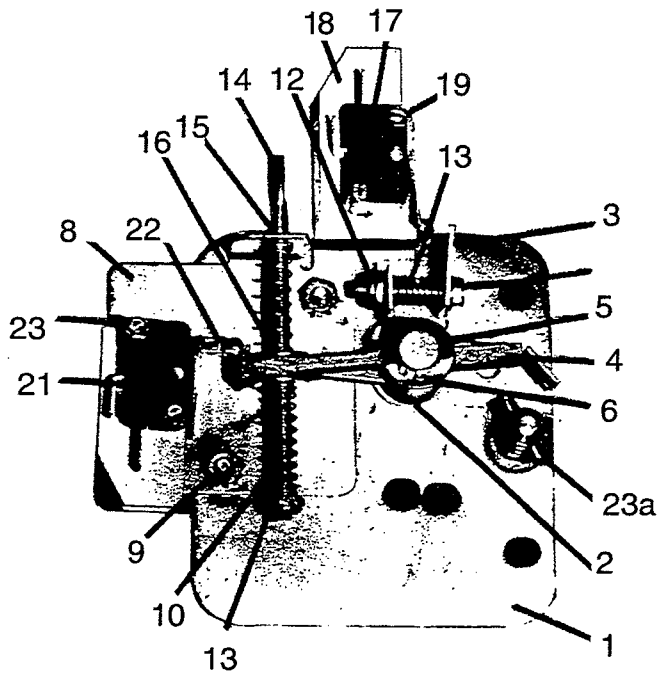
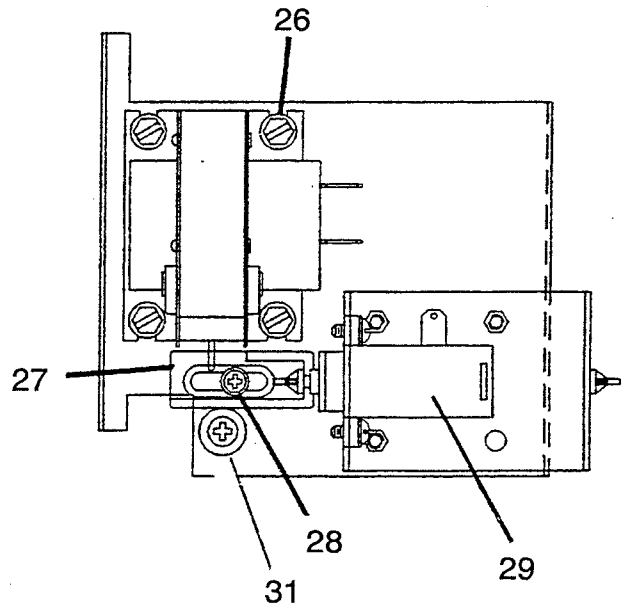
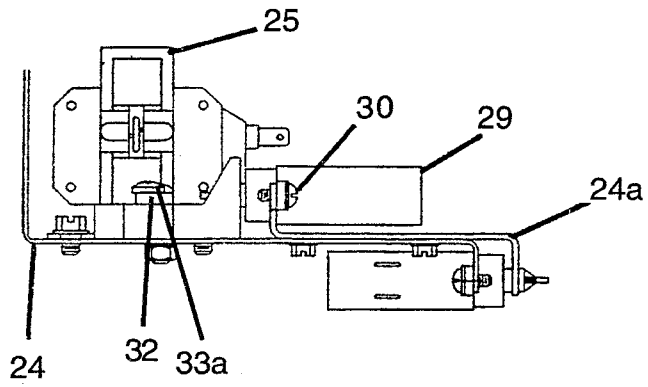

LOADING DOOR GROUP

| Key | Part Number | Description | MODELS | |
|-----|--------------|---|--------|----|
| | | | WCN18 | |
| | | | A | A |
| | | | A | B |
| * | 9960-259-003 | Loading Door, Complete (includes #1 thru #10) | 1 | 1 |
| 1 | 9487-245-001 | Loading Door, Ring | 1 | 1 |
| 2 | 9206-411-002 | Gasket, Loading Door | 1 | 1 |
| 3 | 9635-018-001 | Window, Loading Door Glass | 1 | 1 |
| 4 | 9913-134-003 | Shaft Assy, Locking (includes #5 thru #8) | 1 | 1 |
| 5 | 9537-195-002 | Shaft, Door Locking | 1 | 1 |
| 6 | 9095-040-001 | Cam, Locking | 1 | 1 |
| 7 | 9451-181-005 | Pin, Groove (1 1/4) | 1 | 1 |
| 8 | 9451-181-004 | Pin, Groove (3/4) | 1 | 1 |
| 9 | 9534-360-002 | Spring, Lock Cam | 1 | 1 |
| 10 | 9244-080-003 | Handle, Door | 1 | 1 |
| * | 9451-181-006 | Pin, Door Handle (groove) | 1 | 1 |
| 11 | 9955-029-001 | Hinge Assy, Loading Door | 1 | 1 |
| * | 9545-014-009 | Screw, Hinge Mtg | 3 | 3 |
| * | 8641-582-009 | Lockwasher | 3 | 3 |
| * | 9552-036-001 | Shim, Loading Door Hinge, Thin | AR | AR |
| * | 9552-036-002 | Shim, Loading Door Hinge, Thick | AR | AR |
| 13 | 9451-184-003 | Pin, Loading Door Hinge | 1 | 1 |
| * | 8649-031-000 | Ring, Retaining | 1 | 1 |
| 14 | 9079-122-001 | Clamp, Loading Door Hinge Pin | 1 | 1 |
| 16 | 9545-056-001 | Screw, Loading Door Mtg | 3 | 3 |
| 15 | 9487-251-001 | Ring, Masking | 1 | 1 |
| * | 8640-413-002 | Nut | 4 | 4 |
| | 9732-139-002 | Kit Door Gasket Expansion (large) | | |
| | 9732-139-001 | Kit Door Gasket Expansion (small) | | |

* Not Illustrated

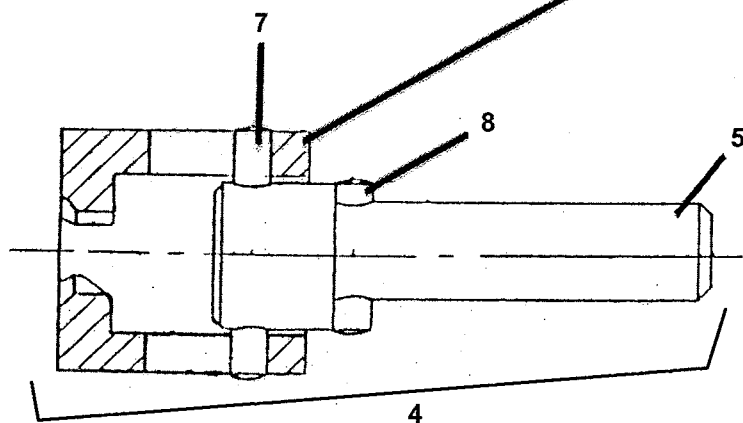
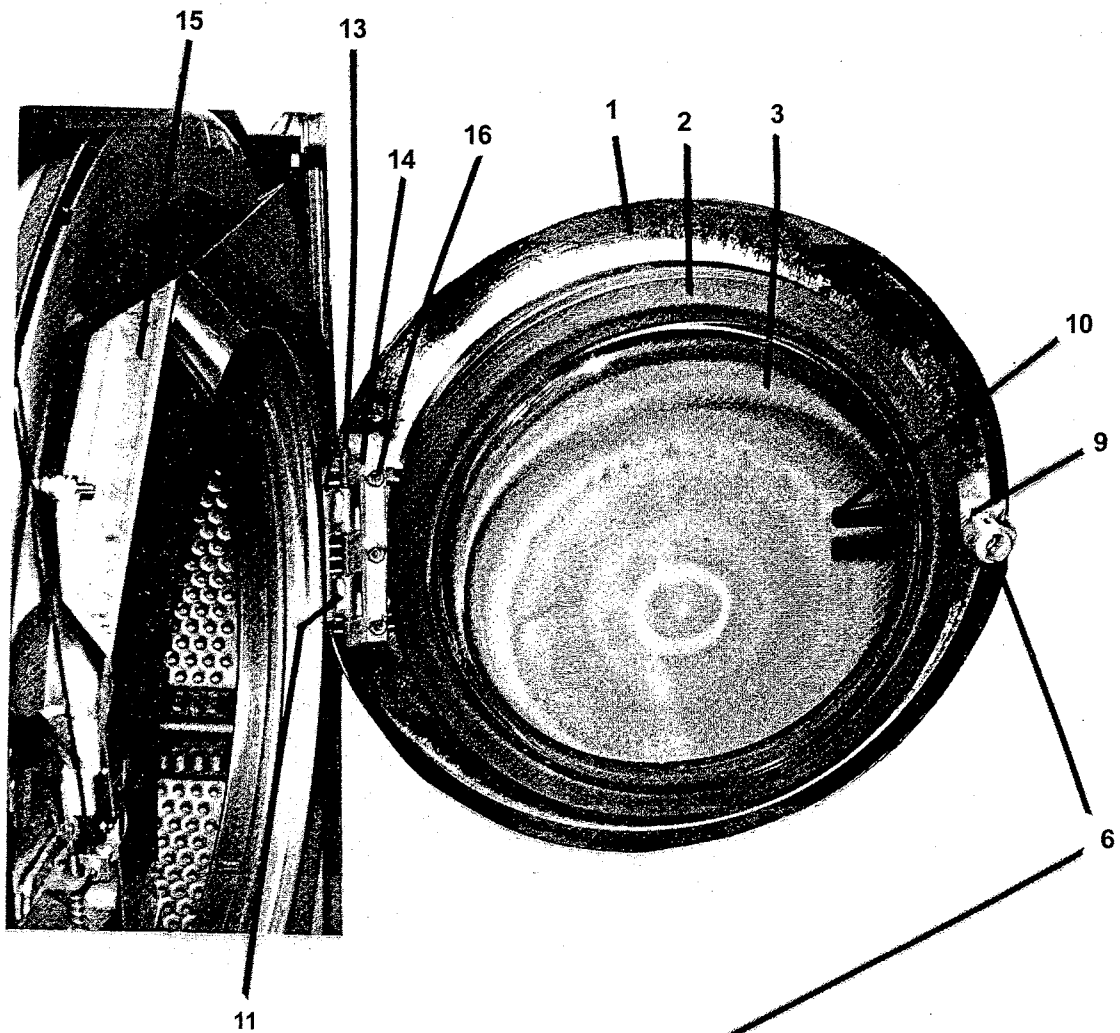

CONTROL PANEL GROUP

| Key | Part Number | Description | MODELS | |
|-----|--------------|---|--------|---|
| | | | WCN18 | |
| | | | A | A |
| | | | A | B |
| 1 | 3310-042-001 | Light, Bleach | 1 | 1 |
| 2 | 3310-041-001 | Light, Cycle Control | 1 | 1 |
| * | 9206-100-001 | Gasket, Light..... | 2 | 2 |
| 3 | 9539-479-009 | Switch, Push-button (cycle selector)..... | 1 | 1 |
| * | 9412-074-003 | Label, Complete (DOUBLE LOAD)..... | 1 | 1 |
| * | 8640-412-005 | Nut, Switch Mtg..... | 2 | 2 |
| * | 9545-031-011 | Screws # 6Tx 5/16 | 4 | 4 |
| 4 | 9021-001-010 | Acceptor, Coin..... | 1 | 1 |
| * | 9545-020-004 | Screw, Acceptor Mtg..... | 4 | 4 |
| * | 8640-424-002 | Nut..... | 4 | 4 |
| * | 9627-682-001 | Harness, Coin Accumulator Wiring..... | 1 | 1 |
| * | 9732-126-001 | Switch, Coin..... | 1 | 1 |
| 5 | 9029-073-001 | Bracket, Solenoid (see Door Lock Group for breakdown) | 1 | 1 |
| 6 | 9020-005-001 | Accumulator, Coin..... | 1 | 1 |
| 7 | 9538-157-003 | Spacer | 3 | 3 |
| 8 | 8640-412-005 | Nut, Hx..... | 6 | 6 |
| 9 | 9550-174-001 | Shield, Circuit Board | 1 | 1 |
| 10 | 9242-450-002 | Hose, Dispenser to Tub | 1 | 1 |
| * | 8654-117-008 | Clamp | 2 | 2 |
| 11 | 9029-066-001 | Side Panel to Tub Front Bracket..... | 1 | 1 |

* Not Illustrated

Control Panel Group

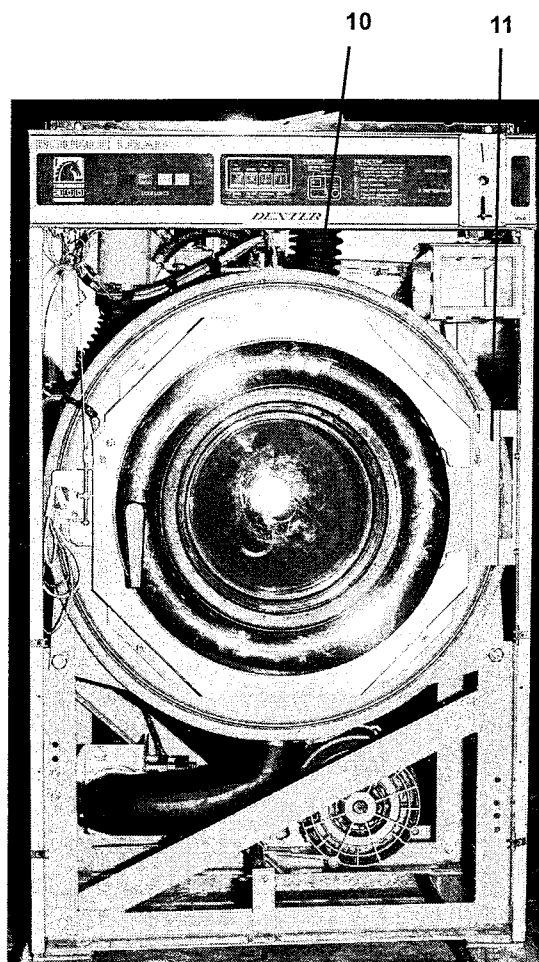
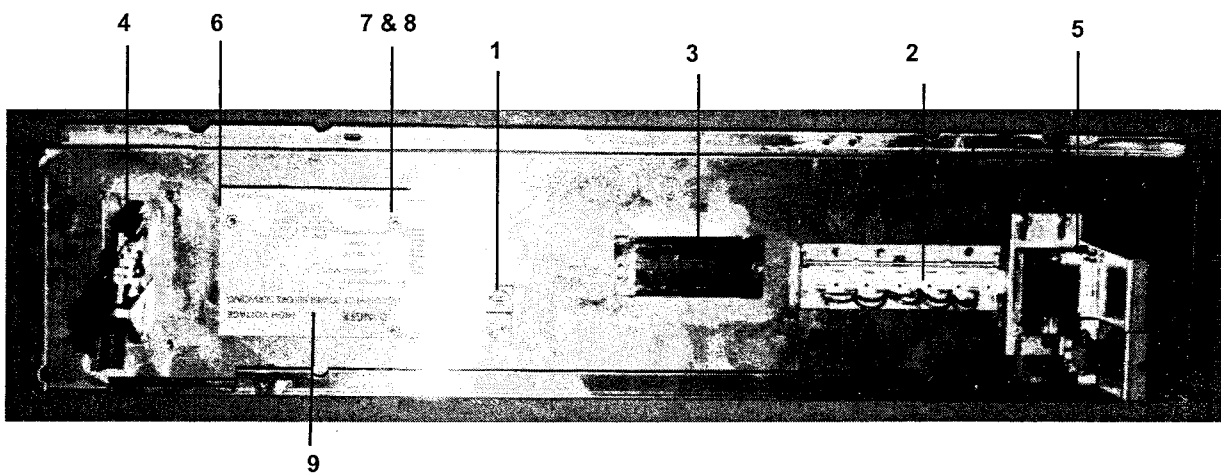

WATER INLET GROUP

| Key | Part Number | Description | MODELS | |
|-----------|---------------------|--|----------|----------|
| | | | WCN18 | |
| | | | A | A |
| | | | A | B |
| 1 | 9379-183-001 | Valve, Water Inlet (see Water Inlet Valve Breakdown for individual parts) | 2 | 2 |
| * | 9545-008-026 | Screw, Valve Mtg | 4 | 4 |
| * | 8640-399-009 | Nut, Spring | 4 | 4 |
| 2 | 9610-001 001 | Vacuum Breaker | 1 | 1 |
| * | 9029-065-001 | Bracket, Vacuum Breaker | 1 | 1 |
| * | 9545-008-026 | Screw | 4 | 4 |
| 3 | 9242-458-001 | Hose, Vacuum Breaker to Tub | 1 | 1 |
| 4 | 8654-117-014 | Clamp, Vacuum Breaker End | 1 | 1 |
| * | 8654-117-009 | Clamp, Tub End | 1 | 1 |
| 5 | 9242-453-020 | Hose, Hot Valve to Vac. Brkr 18" | 1 | 1 |
| 6 | 9242-453-020 | Hose, Hot Valve to Vac. Brkr 18" | 1 | 1 |
| 7 | 9242-453-020 | Hose, Cold Valve to Vac. Brkr 18" | 1 | 1 |
| 8 | 9242-453-020 | Hose, Cold Valve to Vac. Brkr 18" | 1 | 1 |
| 9 | 9242-453-015 | Hose, Vac. Brkr. to Rinse Disp. 12 5/16" | 1 | 1 |
| 10 | 9242-453-016 | Hose, Vac. Brkr. to Wash Disp. 14 1/2" | 1 | 1 |
| 11 | 8654-117-015 | Clamp, Hose-Worm | 12 | 12 |
| * | 5198-211-004 | Circuit Breaker | | 1 |
| * | 5198-211-002 | Circuit Breaker | 1 | |
| 12 | 9242-450-002 | Hose, Dispenser to Tub | 1 | 1 |
| 13 | 8654-117-008 | Dispenser Clamp | 2 | 2 |
| 14 | 9242-463-001 | Overflow hose 9" | 1 | |
| 15 | 9081-099-001 | Channel, Rear | 1 | 1 |
| 16 | 9122-005-004 | Dispenser | 1 | 1 |
| * | 9206-416-001 | Gasket, Dispenser | 1 | 1 |

* Not Illustrated

Water Inlet Group

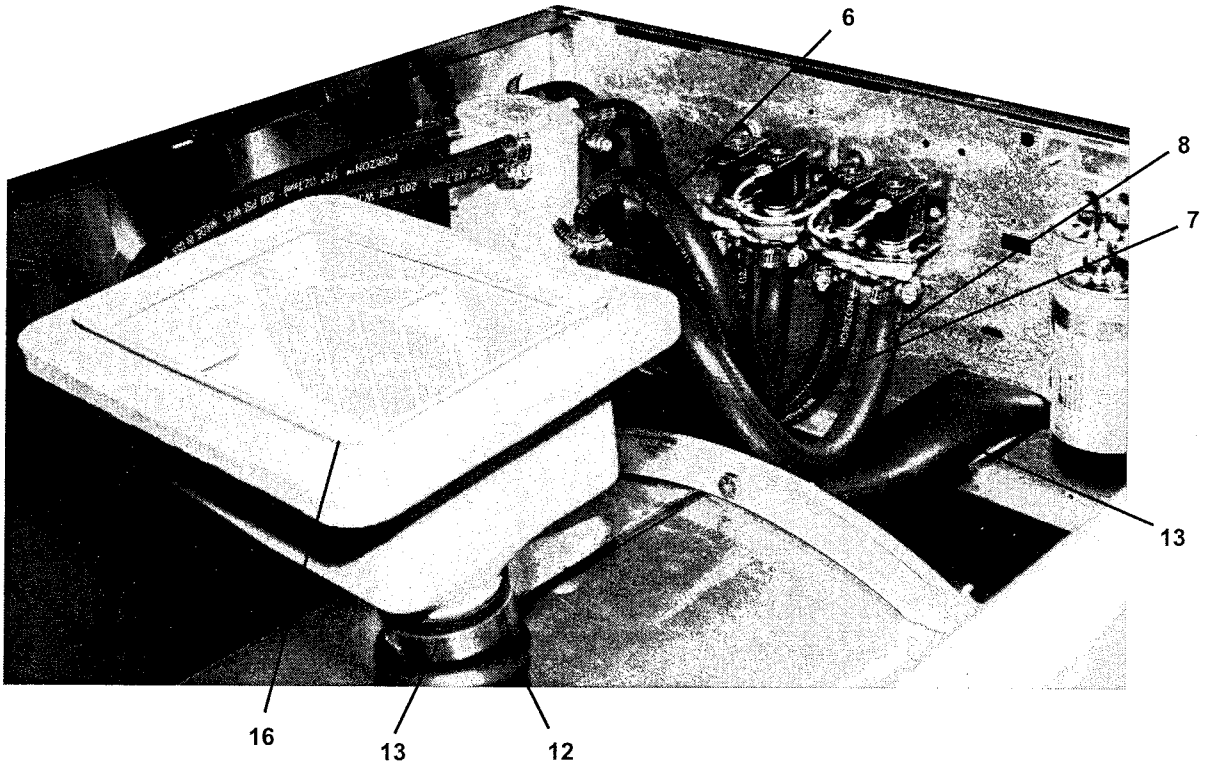
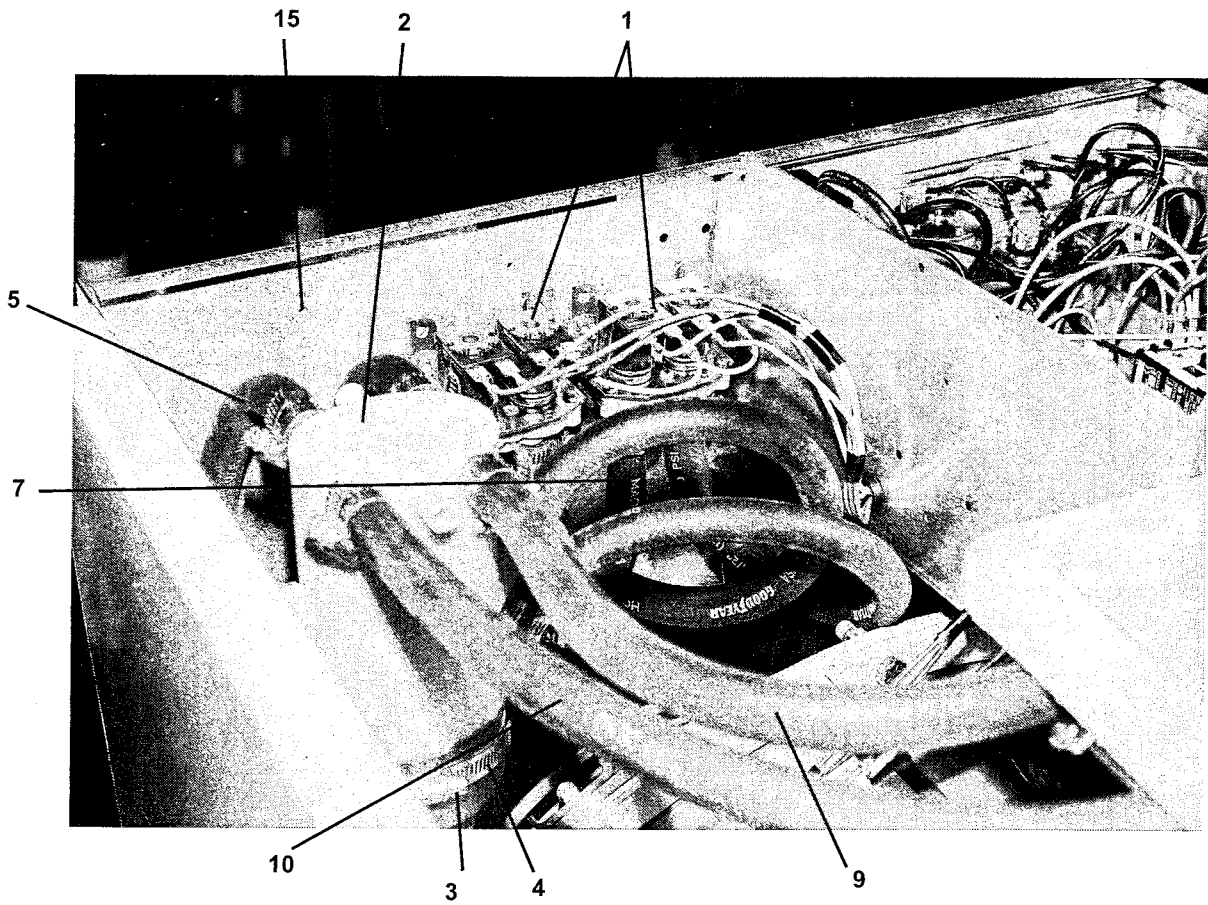

Electrical Components - Top Compartment

Single Phase Only

| Key | Part Number | Description | MODELS | |
|-----|------------------------------------|--|--------|---|
| | | | WCN18 | |
| | | | A | A |
| | | | A | B |
| 1 | 9575-034-001 | Trough Assy, Mtg | 1 | |
| | 9857-125-007 | Control Assy. | | |
| * | 9545-008-026 | Screw, Trough Sides | 2 | |
| * | 9802-037-007 | Service Cord ass'y. | 1 | |
| 2 | 5191-103-007 | Capacitor, Spin-Start | 2 | |
| 3 | 5191-103 006 | Capacitor, Run-Tumble | 1 | |
| | 5192-103-008 | Capacitor, Run-Tumble | 1 | |
| 4 | 9544-055-003 | Strap, Capacitor Mtg | 1 | |
| * | 9545-045-001 | Screw, Capacitor Strap | 2 | |
| 5 | 5192-286-008 | Relay, | 1 | |
| 7 | 9571-362-001 | Timer, Program | 1 | |
| | (VERIFY PART NUMBER ON TIMER BODY) | | | |
| * | 9376-295-002 | Motor, Timer Main Drive | 1 | |
| * | 9376-286-004 | Motor, Timer Rapid Advance | 1 | |
| * | 9545-012-001 | Screw, Timer Mtg | 2 | |
| 8 | 9107-068-001 | Dial, Timer (Decal) | 1 | |
| 9 | 9307-176-001 | Knob, Timer (w/set screws) | 1 | |
| 10 | 9571-360-001 | Timer, Reversing | 1 | |
| * | 9545-044-004 | Screw, Reversing Timer | 2 | |
| 11 | 9897-026-001 | Terminal Block, Power Connection | 1 | |
| * | 9545-045-002 | Screw, Mtg | 2 | |
| * | 8502-619-003 | Label, Fusing | 1 | |
| 13 | 8711-003-001 | Transformer, (For Accumulator) | 1 | |
| * | 9545-045-001 | Screw, Transformer Mtg | 2 | |
| * | 8641-582-005 | Lockwasher | 2 | |
| 14 | 9539-457-001 | Switch, Pressure | 1 | |
| * | 9545-045-001 | Screw, Mtg | 2 | |
| 15 | 5198-211-002 | Circuit Breaker, 7 amp | 1 | |
| * | 9483-002-001 | Resistors, Motorstart | 2 | |

* Not Illustrated

Electrical Components-Top Compartment-1 Phase
(1 phase control trough)

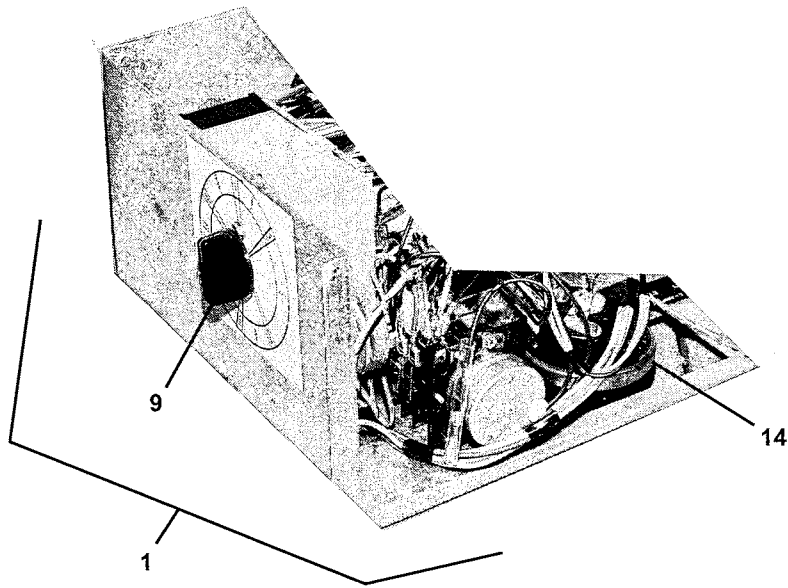
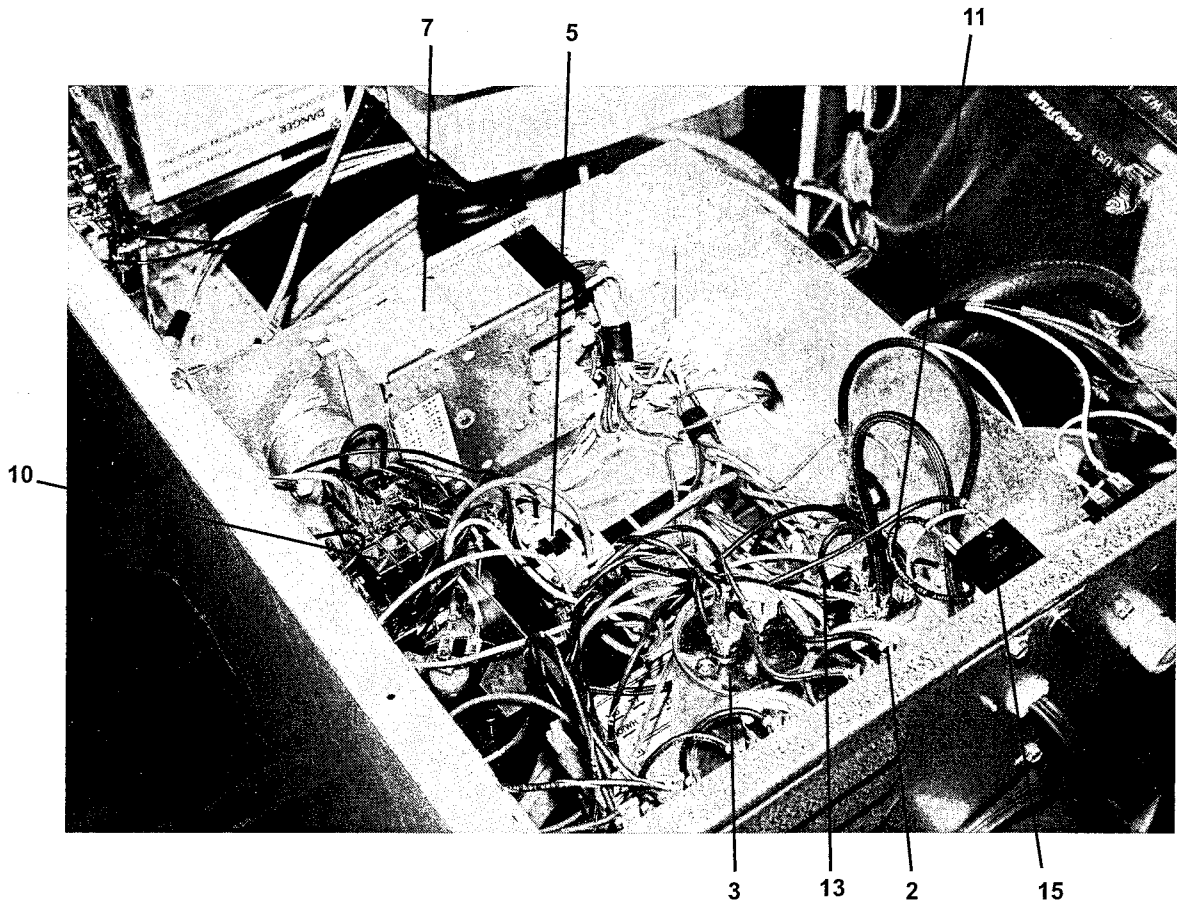

Electrical Components - Top Compartment

Three Phase Only

| Key | Part Number | Description | MODELS | |
|-----|------------------------------------|---|--------|---|
| | | | WCN18 | |
| | | | A | A |
| | | | A | B |
| 1 | 9575-034-001 | Trough Assy, Mtg | | 1 |
| | 9857-125-008 | Control Assy, | | |
| * | 9545-008-026 | Screw, Trough Sides | | 2 |
| 2 | 5192-286-007 | Relay, Tumble | | 2 |
| 3 | 5192-286-009 | Relay, Spin | | 1 |
| 4 | 8711-004-001 | Transformer, Control | | 1 |
| * | 9376-295-002 | Screw, Mtg | | 1 |
| * | 8641-582-006 | Lockwasher | | 1 |
| 5 | 9571-362-001 | Timer, Program | | 1 |
| | (VERIFY PART NUMBER ON TIMER BODY) | | | |
| * | 9376-295-002 | Motor, Timer Main Drive | | 1 |
| * | 9376-286-002 | Motor, Timer Rapid Advance | | 1 |
| * | 9545-012-001 | Screw, Timer Mtg | | 2 |
| * | 9107-068-001 | Dial, Timer | | 1 |
| * | 9307-176-001 | Knob, Timer (w/set screws) | | 1 |
| 6 | 9571-360-001 | Timer, Reversing | | 1 |
| * | 9545-044-004 | Screw, Reversing Timer | | 2 |
| 7 | 9897-035-002 | Terminal Block, Power Connection (4 pole) | | 1 |
| * | 9545-045-002 | Screw, Mtg | | 2 |
| * | 8502-619-004 | Label, Fusing | | 1 |
| 8 | 9897-026-001 | Terminal Block Assy, POWER | | 1 |
| * | 9545-045-002 | Screw, Mtg | | 2 |
| * | 9558-029-002 | Strip, Terminal Marker | | 1 |
| 9 | 8711-003-001 | Transformer, (For Accumulator) | | 1 |
| * | 9545-045-001 | Screw, Transformer Mtg | | 2 |
| * | 8641-582-005 | Lockwasher | | 2 |
| 10 | 9539-457-001 | Switch, Pressure | | 1 |
| * | 9545-045-001 | Screw, Mtg | | 2 |
| * | 5198-211-004 | Circuit Breaker, 1.5 amp | | 1 |

* Not Illustrated

Electrical Components-Top Compartment-3 Phase

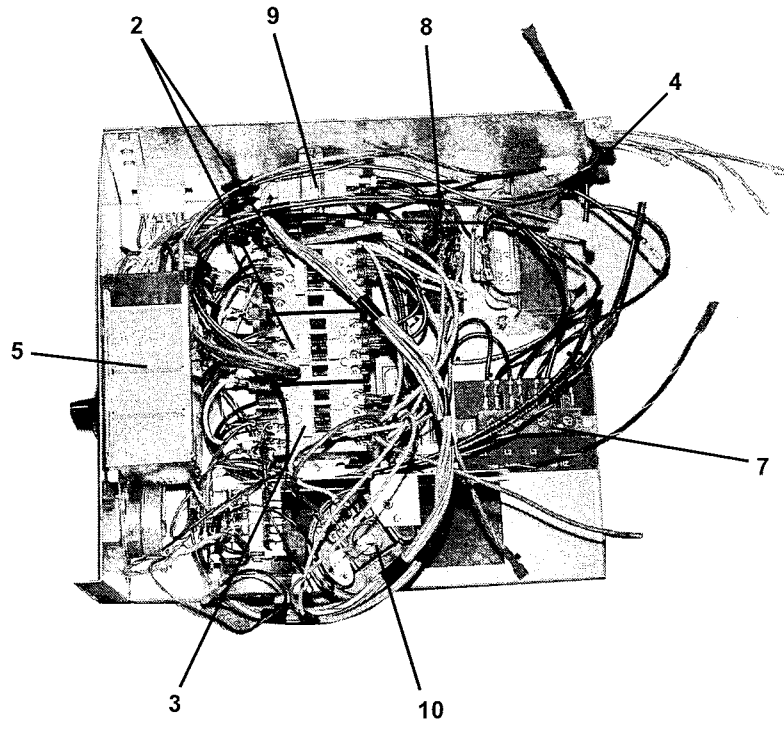
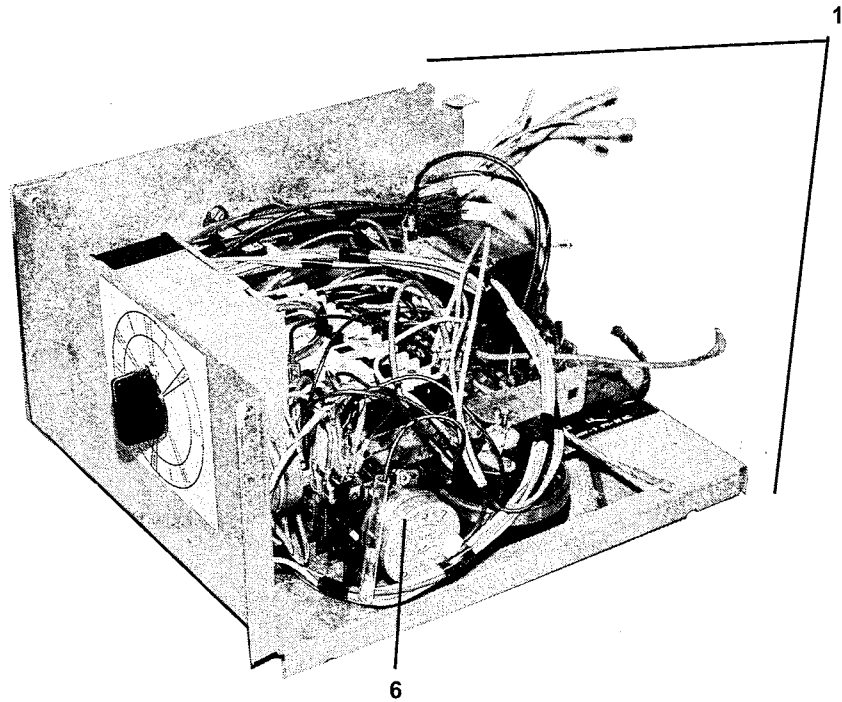

Coin Handling Group

MODELS
WCN18
A A
A B

| Key | Part Number | Description | A | B |
|--|--------------|---|---|---|
| * | 9942-024-007 | Vault, Assy | 1 | 1 |
| * | 9545-008-026 | Screw, Vault Mtg | 4 | 4 |
| NOTE: COIN BOX AND HARDWARE KIT AND COIN BOX LOCK NOT INCLUDED WITH MACHINE. | | | | |
| 2 | 9732-122-001 | Kit, Coin Box W/Hardware(#2-#6) | 1 | 1 |
| 3 | 9349-033-001 | Latch, Coin Box | 1 | 1 |
| 4 | 8641-569-002 | Washer, Wave | 1 | 1 |
| 5 | 8641-583-001 | Washer, Keeper | 1 | 1 |
| 6 | 8641-581-008 | Washer, Spacer- Thick | 2 | 2 |
| 6 | 8641-581-010 | Washer, Spacer- Thin | 4 | 4 |
| 7 | 8650-012-003 | Lock, Coin Box (w/key not included with 9732-122-001) | 1 | 1 |
| 8 | 9021-001-010 | Acceptor, Coin..... | 1 | |
| 1 | | | | |
| * | 9545-020-004 | Screw, Acceptor Mtg..... | 4 | 4 |
| * | 8640-424-002 | Nut..... | 4 | 4 |
| 9 | 9732-126-001 | Switch, Coin..... | 1 | 1 |
| 10 | 9119-025-002 | Acceptor Chute Ass'y w/o penny ejectorstandard | 1 | 1 |
| 11 | 9486-133-001 | Button Coin Return Retainer | 1 | 1 |
| 12 | 9119-025-001 | Acceptor Chute Ass'y w/ penny ejectoroptional | 1 | 1 |

* Not Illustrated

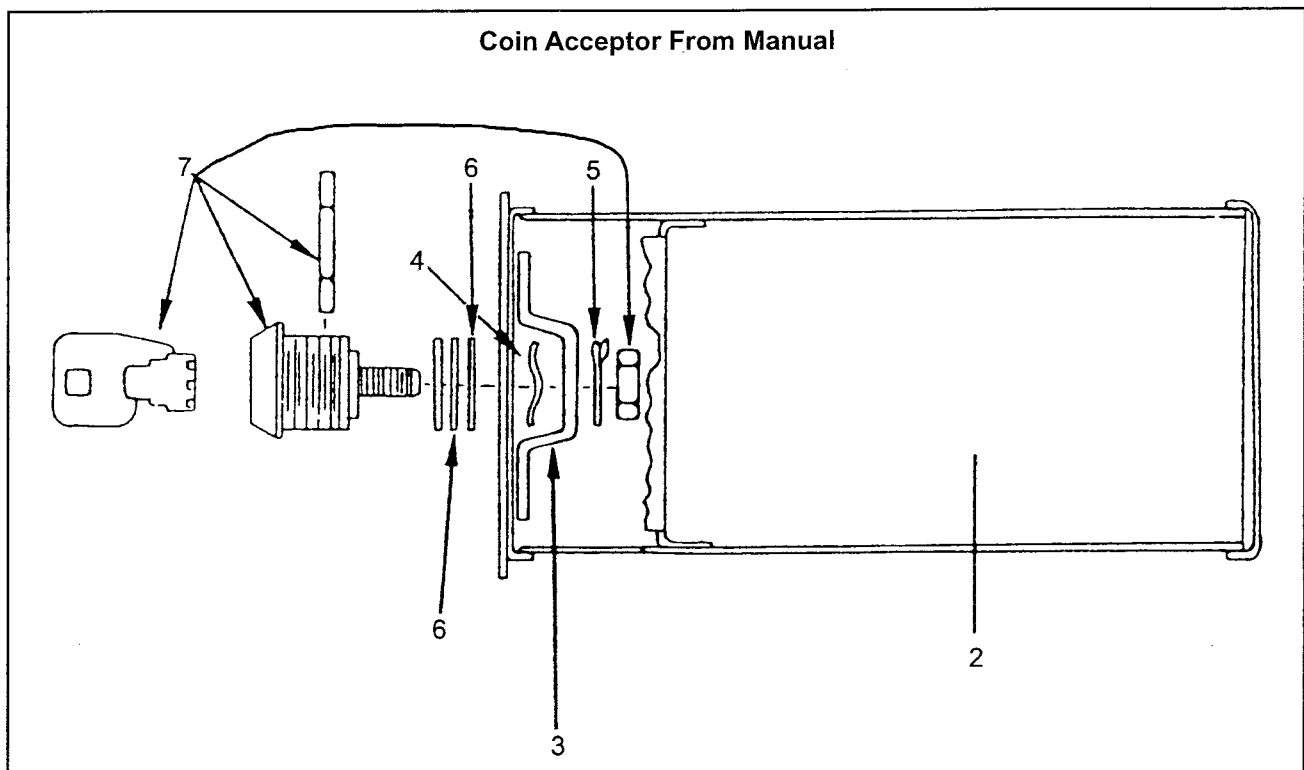

Coin Handling Group

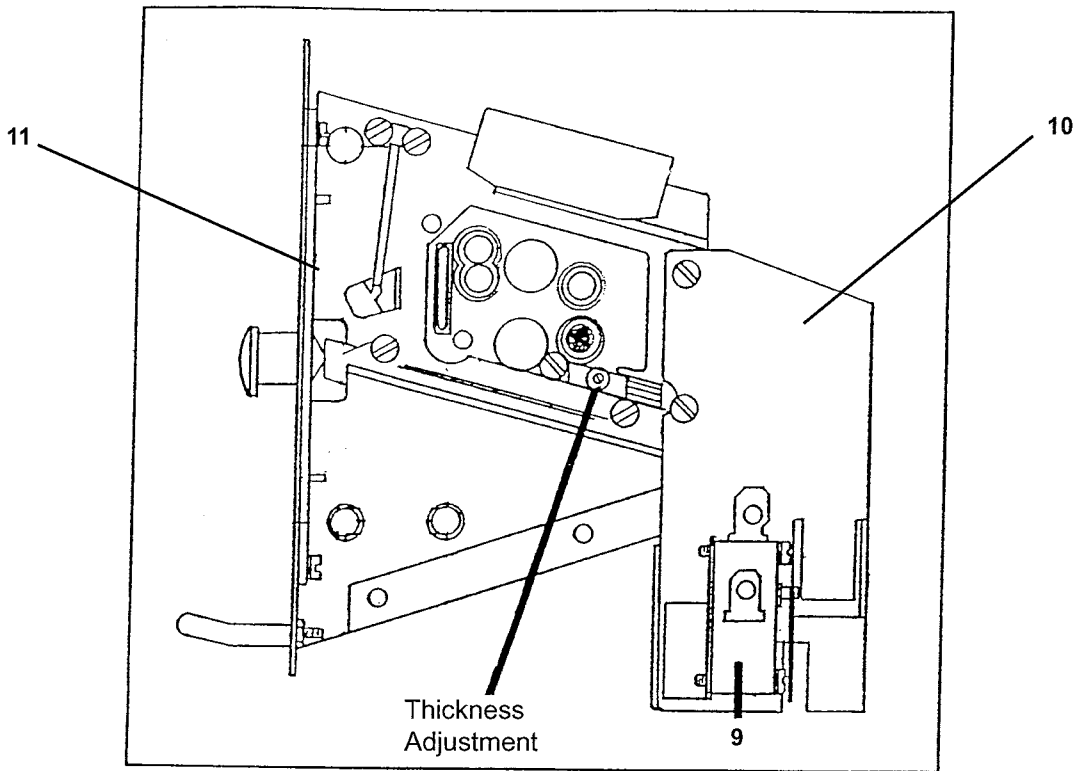

#8 COIN ACCEPTOR - right side

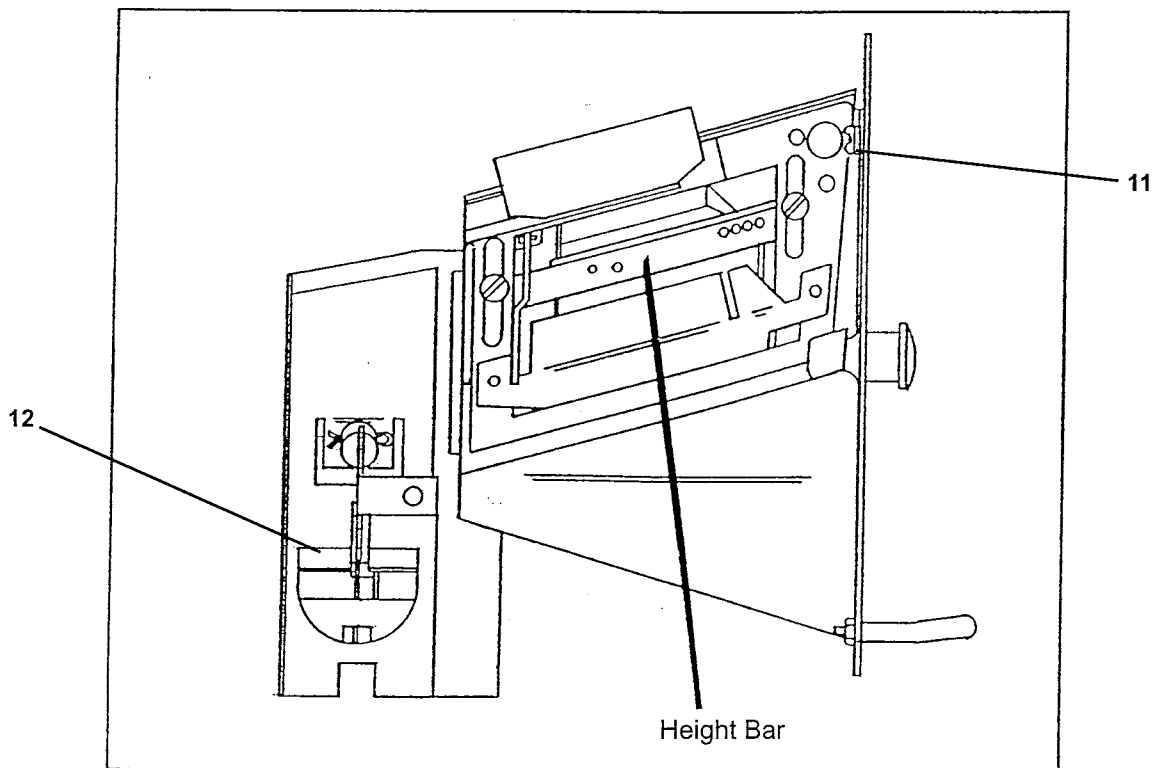

#8 COIN ACCEPTOR - left side

Water Inlet Valve Breakdown

| Key | Part Number | Description | MODELS | |
|-----|--------------|--|--------|---|
| | | | WCN18 | |
| | | | A | A |
| | | | A | B |
| | 9379-183-001 | Valve, Water Inlet (includes #1 thru #6) | 2 | 2 |
| 1 | 9555-056-001 | Screen, Inlet | 2 | 2 |
| 2 | 9089-017-001 | Coil Assy., 120 V | 2 | 2 |
| 3 | 9118-049-001 | Diaphragm | 2 | 2 |
| 4 | 9211-021-002 | Guide, Solenoid | 2 | 2 |
| 5 | 9015-008-001 | Armature | 2 | 2 |
| 6 | 9534-298-001 | Spring, Armature | 2 | 2 |

Water Inlet Valve Breakdown

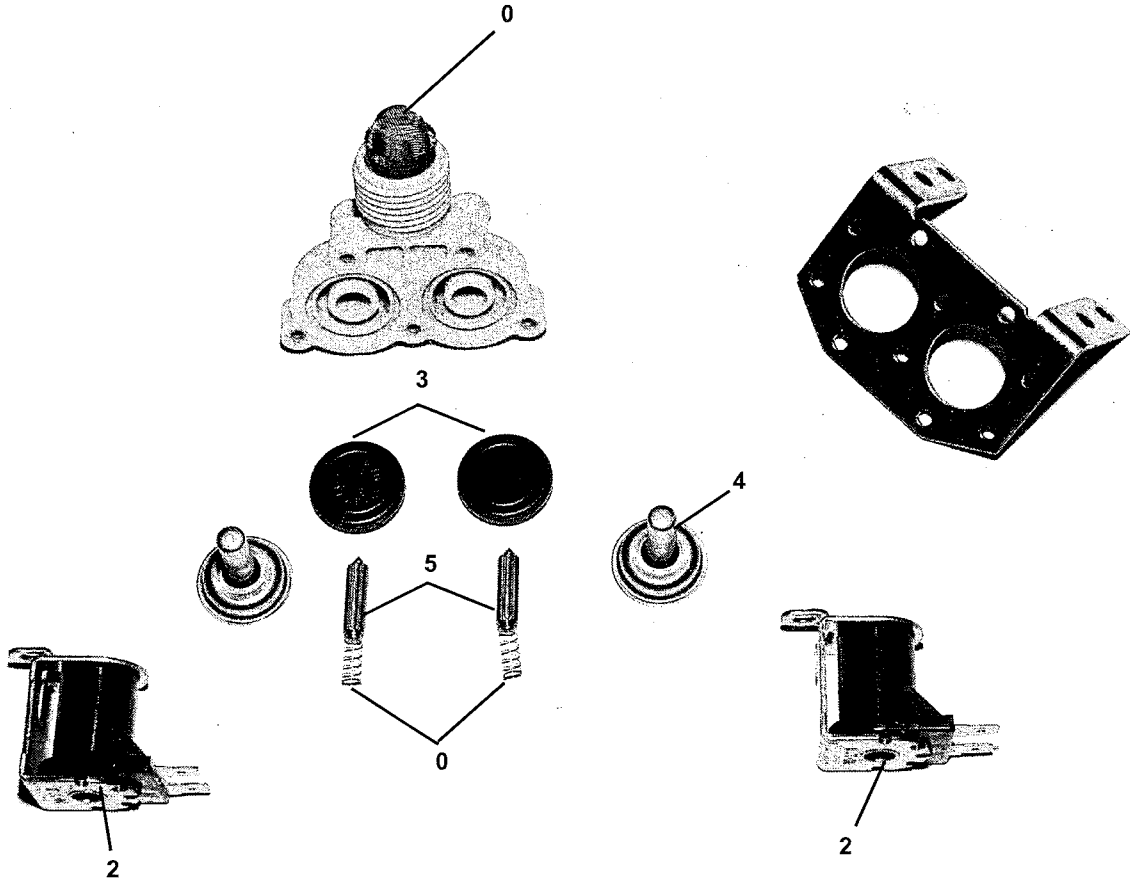

DRAIN VALVE GROUP

| Key | Part Number | Description | MODELS | |
|-----|--------------|---|--------|---|
| | | | WCN18 | |
| | | | A | A |
| | | | A | B |
| | 9379-177-006 | Valve, Drain (includes #2 thru #11) | 1 | 1 |
| 2 | 9064-068-001 | Body, Valve (w/ball) | 1 | 1 |
| 3 | 9914-137-001 | Motor & Gear Train | 1 | 1 |
| 4 | 9452-538-001 | Plate, Motor Mtg | 1 | 1 |
| 5 | 8639-994-001 | Screw | 3 | 3 |
| 6 | 9534-340-001 | Spring, Drive | 1 | 1 |
| 7 | 9545-054-001 | Screw | 2 | 2 |
| 8 | 9545-054-002 | Screw | 1 | 1 |
| 9 | 9532-134-001 | Seal, V Packer | 2 | 2 |
| 10 | 8641-584-001 | Washer | 1 | 1 |
| 11 | 9451-196-001 | Pin, Main Drive | 1 | 1 |
| 12 | 9538-149-001 | Plate (spacers needed for replacement motor mtg. plate) | 4 | 4 |

Drain Valve Group

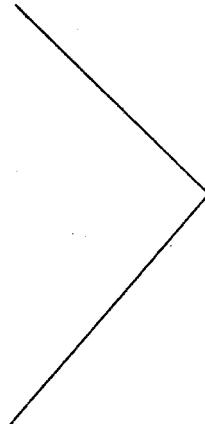
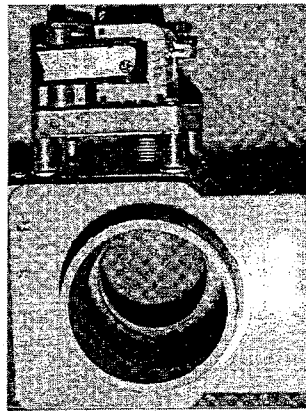
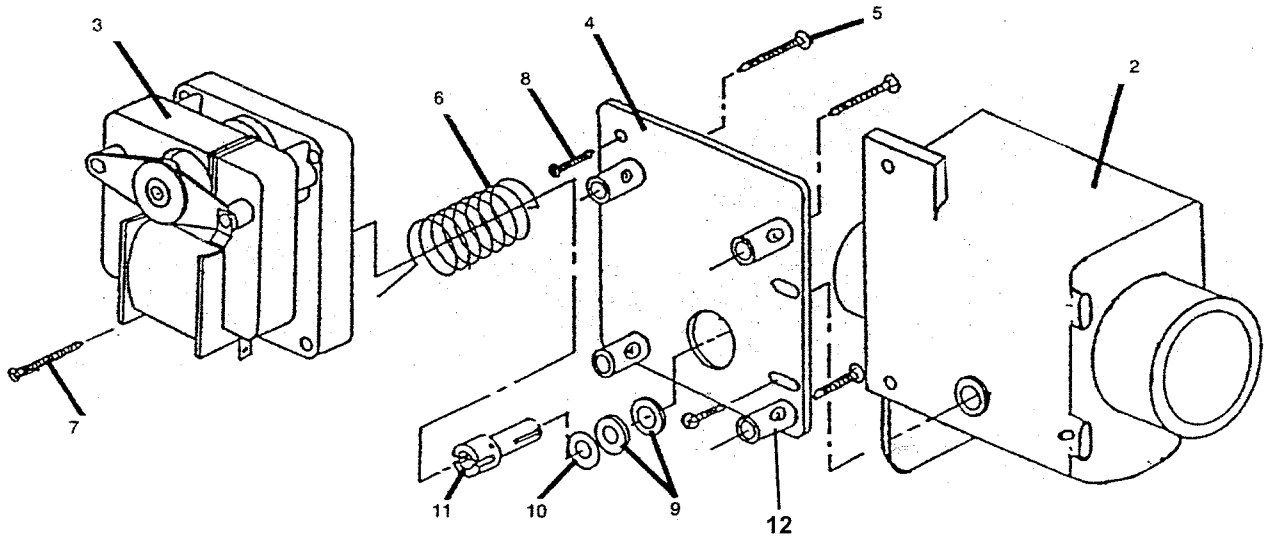

Valve
Complete

WIRING HARNESS GROUP

| Key | Part Number | Description | MODELS | |
|-----|--------------|--|--------|---|
| | | | WCN18 | |
| | | | A | A |
| | | | A | B |
| | 9627-696-002 | Wiring Harness, Main | 1 | 1 |
| | 9627-689-001 | Wiring Harness, Control | 1 | 1 |
| | 9627-708-001 | Wiring Harness, Coin accumulator (countdown) | 1 | 1 |
| | 8654-125-001 | Clamp, Cable- 1/4 Dia. | 1 | 1 |

LABELS

| | | | |
|--------------|--------------------------------------|---|---|
| 8502-620-001 | Label-Motorconnection | 1 | |
| 8502-622-002 | Label--Nameplate | 1 | |
| 8502-619-003 | Label--Fusing&Installation | 1 | |
| 8502-619-004 | Label-Fusing & Installation | | 1 |
| 8502-614-004 | Label--Warning,Highvoltage | 1 | |
| 8502-624-002 | Label---Warning, Door opening | 1 | |
| 8507-273-001 | Instructions---SPIN direction | 1 | |
| 8511-001-002 | Label---QUALITY | 1 | |
| 9345-790-002 | Label----Wiring Schematic | 1 | |
| 9345-791-002 | Label--Wiring Diagram | 1 | |
| 9345-792-001 | Label--Wiring Schematic | | 1 |
| 9345-793-002 | Label--Wiring Diagram | | 1 |
| 8507-230-001 | Instructions-Transformer Connections | | 1 |

Section 8

Maintenance

Daily

1. Clean the top and the cabinet to remove residue.
2. Clean the soap dispenser and soap lid.
3. Check the drain for leaking and proper draining.
4. Check the loading door for leaks.
5. Clean the door seal of all foreign material.
6. Leave the loading door open to aerate the washer when not in use.

Quarterly

Make sure the power is disconnected before making the following checks.

1. Check the drive belt for wear and proper tension.
2. Clean lint and other foreign material from around drive motor.
3. Check all water connections for leaks.
4. Wipe and clean the inside of the washer and check all electrical components for moisture and dust.
5. Remove and clean water inlet hose filters. Replace if necessary.
6. After any service always replace all panels before reconnecting electrical power.

**THE
DEXTER
COMPANY**

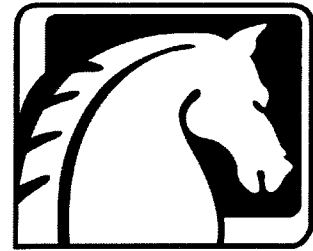

**18 Lb. OPL Washers
Thoroughbred 300
WCN 18DX**

**Service Procedures and Parts Data
Thoroughbred 300**



WARNING

These Washers are equipped with devices and features relating to their safe operation. To avoid injury or electrical shock, do not perform any service, unless qualified to do so.

A machine should not be allowed to operate if any of the following occur:

- Excessively high water level.**
- Machine is not connected to a properly grounded circuit.**
- Loading door does not remain securely locked during the entire cycle.**
- Vibration or shaking from an inadequate mounting or foundation.**

Warning - For Safety

- 1. Always shut off power and water supply and also discharge capacitors before servicing.**
- 2. Do not overload the washer.**
- 3. Do not attempt to open door if cylinder is in motion or contains water.**
- 4. Do not mechanically force or override door lock in any way.**
- 5. Do not bypass any safety devices of this washer.**
- 6. Do not use volatile or flammable substances in or near this washer.**
- 7. Keep all panels in place. they protect against shock and injury and add rigidity to the washer.**

Section 9

Trouble Shooting

| Symptom | Probable Cause | Suggested Remedy |
|---|------------------------------------|---|
| Machine does not start | Power Supply | Check these areas: Circuit breakers, Voltage, Power leads, Power connections |
| | Door Switch | Check for continuity through door switch when door closed. If no continuity, adjust or replace door switch. |
| | Control Breaker | Check (1.5 amp on 3 phase) (7 amp on 1 phase) breaker for continuity. Replace breaker if no continuity. |
| | Control Transformer (3 phase only) | Check voltage output from control transformer for 120VAC. If voltage is incorrect, replace transformer. |
| | Timer | Check to insure that the timer is in the "off" position to supply 120VAC through the "Start" cam |
| | Timer, Rapid Advance Motor | Check the rapid advance motor for continuity and replace if no continuity. |
| | "Start " Switch | When actuated there must be continuity through the contacts on the start switch |
| Machine starts but timer will not advance | Main Timer Drive Motor | If 120VAC is supplied to timer motor, but it doesn't operate, replace timer motor. |

| Symptom | Probable Cause | Suggested Remedy |
|--------------------|-----------------------|--|
| Door does not lock | Timer Position | The following sequence must have taken place to advance the timer before the door locks. -Loading door closed -Timer initially in "Off" position. -Push Start button -Timer advances to "On" position |
| | Door locking solenoid | Check to insure that solenoid is receiving 120VAC from S1 door switch. If it is, replace solenoid. |
| | Door Switch | Check for continuity through door latch switch(es) when door closed. If no continuity, adjust or replace door switch. |
| Door will not open | Thermoactuator | Check to see if thermoactuator(s) and/or its mechanism is stuck or binding and not allowing the door lock solenoid to open. Check to be sure that the locking thermoactuator is not receiving 120VAC during the last 1 1/2 minutes of the cycle. Also check to see that the unlocking thermoactuator is receiving 120VAC during the last minute of the cycle. If the thermoactuators do not receive voltage at the correct times, change the timer. If the timing and voltage are correct, replace the thermoactuator. |
| | Door Rod | Check to see that door rod from solenoid to lock ass'y is long enough to allow lock ass'y to disengage. If not, adjust rod. |
| | Door Lock Solenoid | Check that door lock solenoid is not stuck closed. If stuck, replace solenoid. |
| | Timer | Make sure machine is in "off" position allowing timer to authorize door unlock. |

| Symptom | Probable Cause | Suggested Remedy |
|-------------------------------------|-----------------------------------|---|
| Hot water does enter tub in wash | Water Valve Coil | Check coil continuity at terminals and replace if not no continuity. |
| | Water Inlet Screens | Check water inlet screens for blockage and clean if necessary. |
| | Water | Check to insure that water is turned on and operating. |
| | Timer | Advance machine into wash cycle and check for 120VAC at red/blue wire coming from timer. |
| | Water Temperature Selector Switch | Check switch for continuity between red/blue wire and red/yellow wire when Hot is selected. If no continuity, change switch. |
| | Pressure Switch | Check pressure switch continuity between terminals #1 & #2. If no continuity, check pressure switch hose for obstruction. If hose okay, change pressure switch. |
| No cold water to tub in wash | Water Valve Coil | Check coil continuity at terminals and replace if no continuity. |
| | Water Inlet Screens | Check water inlet screens for blockage and clean if necessary. |
| | Water | Check to insure that water is turned on and operating. |
| | Pressure Switch | Check pressure switch continuity between terminals #1 & #2. If no continuity, check pressure switch hose for obstruction. If hose okay, change pressure switch. |
| | Timer | Choose cold cycle, advance to wash, check for voltage on white/black from timer. If no voltage, replace timer. |
| | Water Temperature Selector Switch | Choose cold cycle, advance to wash and check wht/org wire from selector switch for 120VAC. If no voltage, change switch. |
| No hot water in detergent dispenser | Water Valve Coil | Check coil continuity at terminals and replace if no continuity. |
| | Water Inlet Screens | Check water inlet screens for blockage and clean if necessary. |
| | Water | Check to insure that water is turned on and operating. |

| Symptom | Probable Cause | Suggested Remedy |
|--|-------------------------------------|--|
| No hot water detergent dispenser (continued) | Timer | Advance to wash, check for voltage on red/org in from timer. If no voltage, replace timer. |
| Water does not flush softener compartment. | Water Valve Coil | Check coil continuity at terminals and replace if no continuity. |
| | Water Inlet Screens | Check water inlet screens for blockage and clean if necessary. |
| | Water | Check to insure that water is turned on and operating. |
| | Pressure Switch | Check pressure switch continuity between terminals #1 & #2. If no continuity, check pressure switch hose for obstruction. If hose okay, change pressure switch. |
| | Timer | Advance machine to final rinse and check for voltage at wht/blue wire coming from timer. If no voltage, replace timer. |
| Water comes in but level does not rise | Drain Valve (open) | Check these areas <ul style="list-style-type: none"> - Drain valve blockage - Drain valve motor and gear train. If power but drain valve does not close, replace valve. - Power to the drain valve. If no power to drain valve, check (brn/yel) circuit for power. |
| Water level too high | Pressure Switch | Check for blockage in pressure switch hose. Check for pressure switch opening circuit across terminals #1 & #2. Replace switch if contacts do not open. |
| Water drains slowly | Drain System | Check hoses and drain valve for blockage. Clean if necessary. Check building drains for blockage or inadequate size. |
| Machine does not tumble | R2 Spin Relay | Check continuity between terminals #13 & #14 on R2 relay. |
| | Wash Speed Capacitor (1 phase only) | Check capacitor and replace if failed. |

| Symptom | Probable Cause | Suggested Remedy |
|--|-------------------------------------|--|
| Machine tumbles in only one direction | Reversing Timer | Check to see that reversing timer is running. Check for alternating 120VAC at orange/green and at brown/white from reversing timer to signal reversing operation to wash relays. If not running or no voltage, replace reversing timer. |
| | Tumble Relays | Check R1A and R1B tumble speed relays. If one does not close during tumble speed, check coil continuity and power to the relay. If 120VAC to relay and no coil continuity, replace relay. |
| Machine does not spin | Spin Relay | Check spin relay coil for continuity, replace if no coil continuity. Check relay contacts, replace if no continuity. |
| | Pressure Switch | Check pressure switch for continuity across terminals #1 & #2 indicating pressure switch has reset to the empty position. If no continuity, change pressure switch. |
| | Spin Start Capacitor (1 phase only) | Check capacitor and replace if failed. |
| | Motor Overload | Check vio/wht wire at terminal strip and vio wire at spin relay for continuity. If open, replacement motor must be considered. |
| Machine starts and advances through cycle motor does not operate | Reversing Timer | Check to see that reversing timer is running. Check for alternating 120VAC at orange/green and at brown/white from reversing timer (3 ph.) [1phase-120vac Blk/orange and Blk/white] to signal reversing operation to wash relays. If not running or no voltage, replace reversing timer. |
| Machine does not stop at end of cycle | Main Timer | Check that power (120vac) are NOT at #43 Red from timer contact 3 T. If power at all times replace timer. |
| Water leakage around loading door | Door Adjustment | Door may need adjustment due to abuse or wear. Check tightness around perimeter using a dollar bill. Adjust left to right tightness by shims at door lock or hinge side. It is important to center gasket to tub opening before tightening door to hinge bolts. Chalk may be used on tub front to show point of contact with tub. If gasket is deformed, worn, or damaged, replace. Refer to parts section for door gasket expander kit. |

Symptom**Probable Cause****Suggested Remedy**

Excessive vibration

Mounting System

Check these areas:

- Strength of mounting structure, concrete or base.
- Mounting bolts may be loose and need tightening.

Drive Belt
PulleysWorn drive belt can cause vibration and noise.
-Damaged pulleys

Loading

NOTE: SMALL LOADS CONTRIBUTE TO OUT OF BALANCE LOADING AND INCREASE VIBRATION.

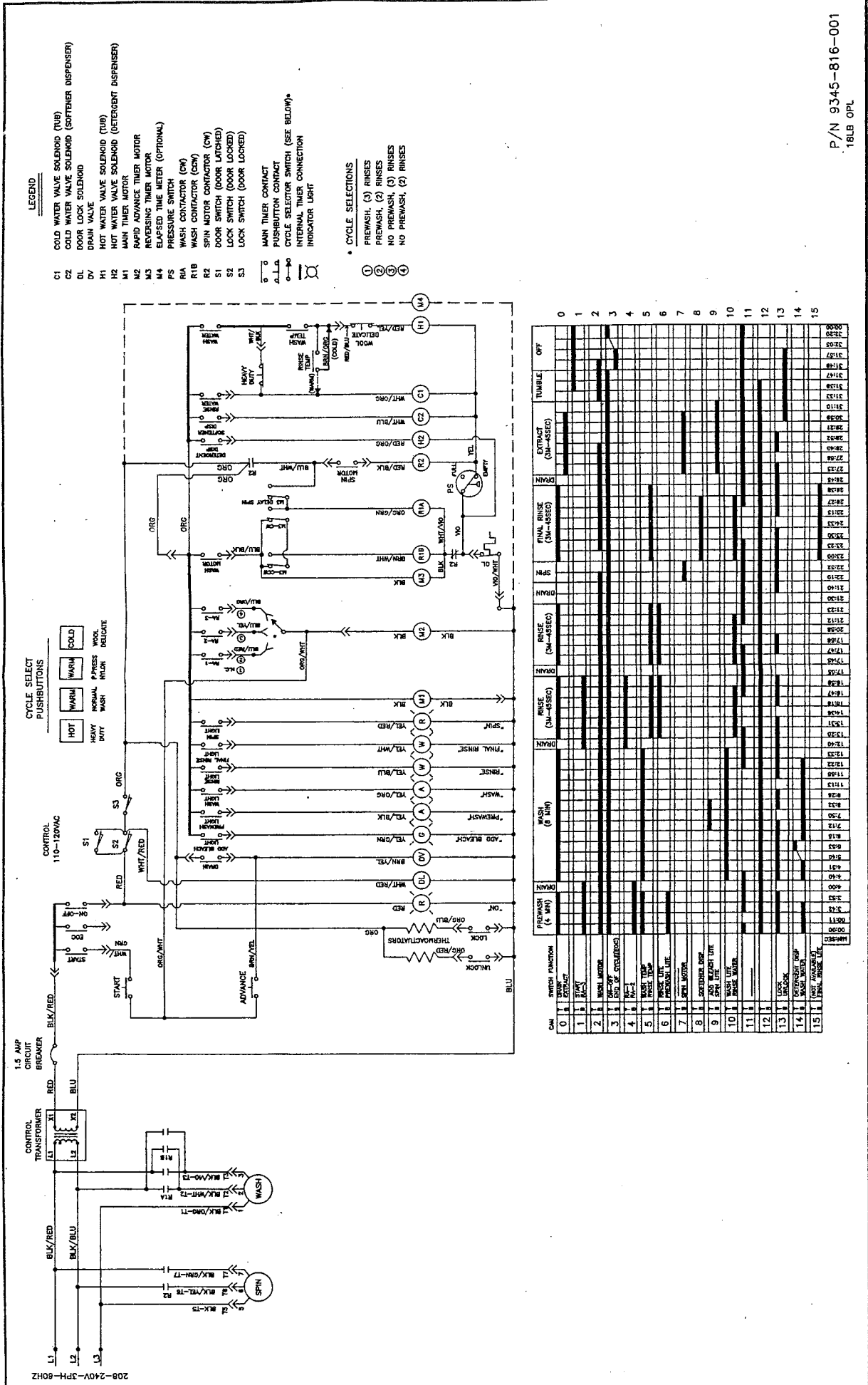

WIRING SCHEMATIC 208-240V-3PH-60HZ

P/N 9345-816-001
1BLB OPL

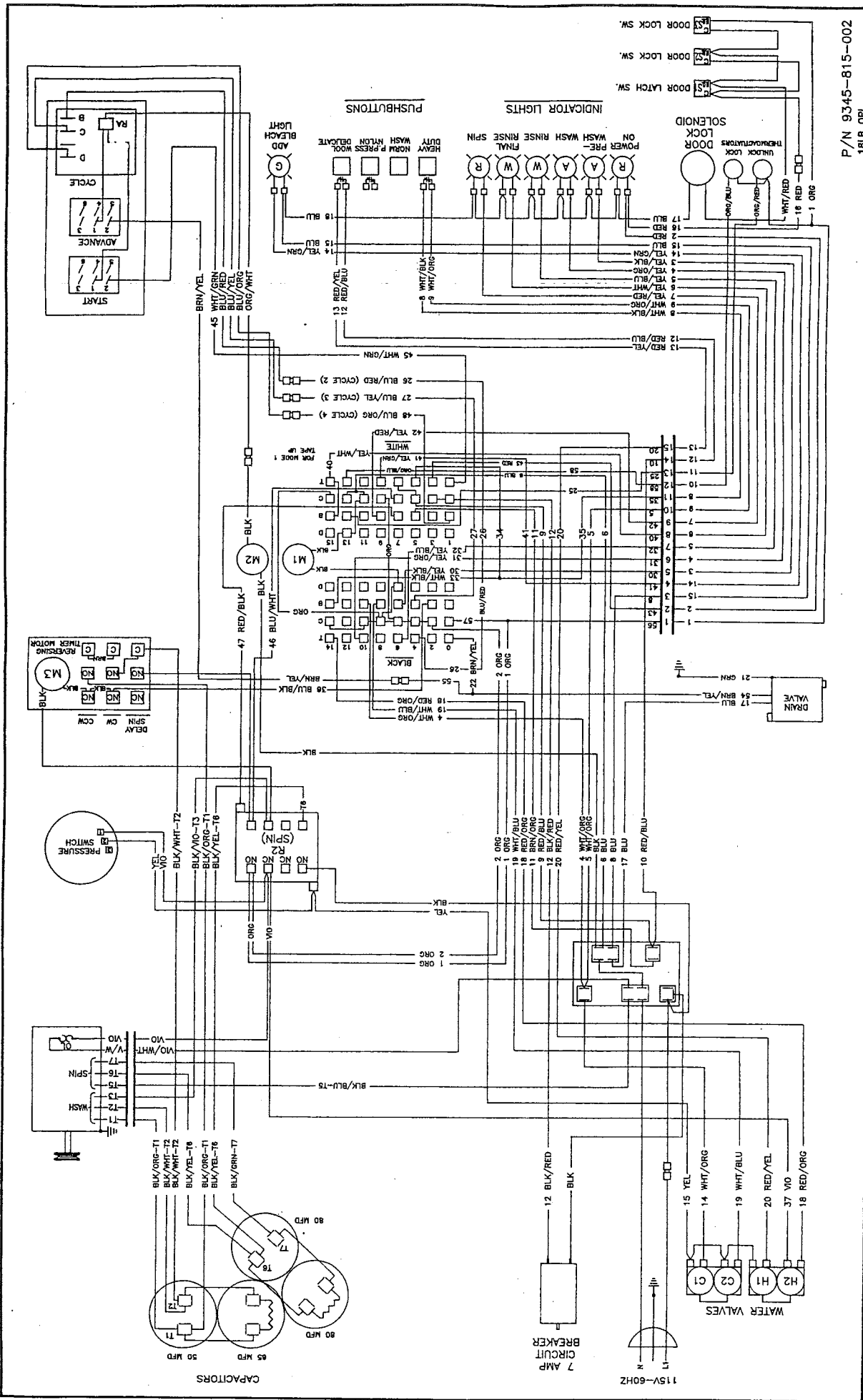

P/N 9345-815-002
18LB OPL

WIRING DIAGRAM 115V-1PH-60HZ

300 SERIES INDUSTRIAL WASHER MOUNTING DIMENSIONS

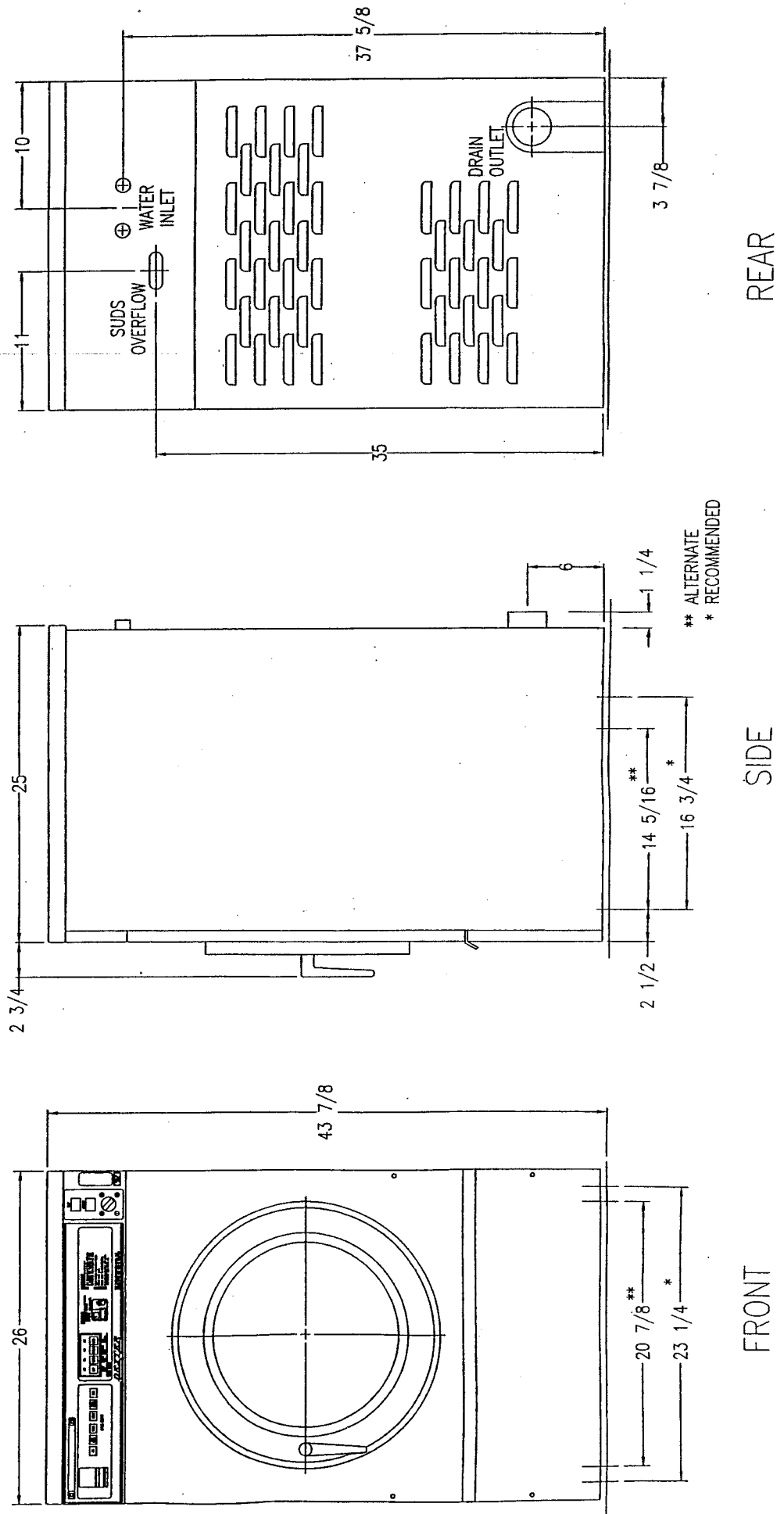

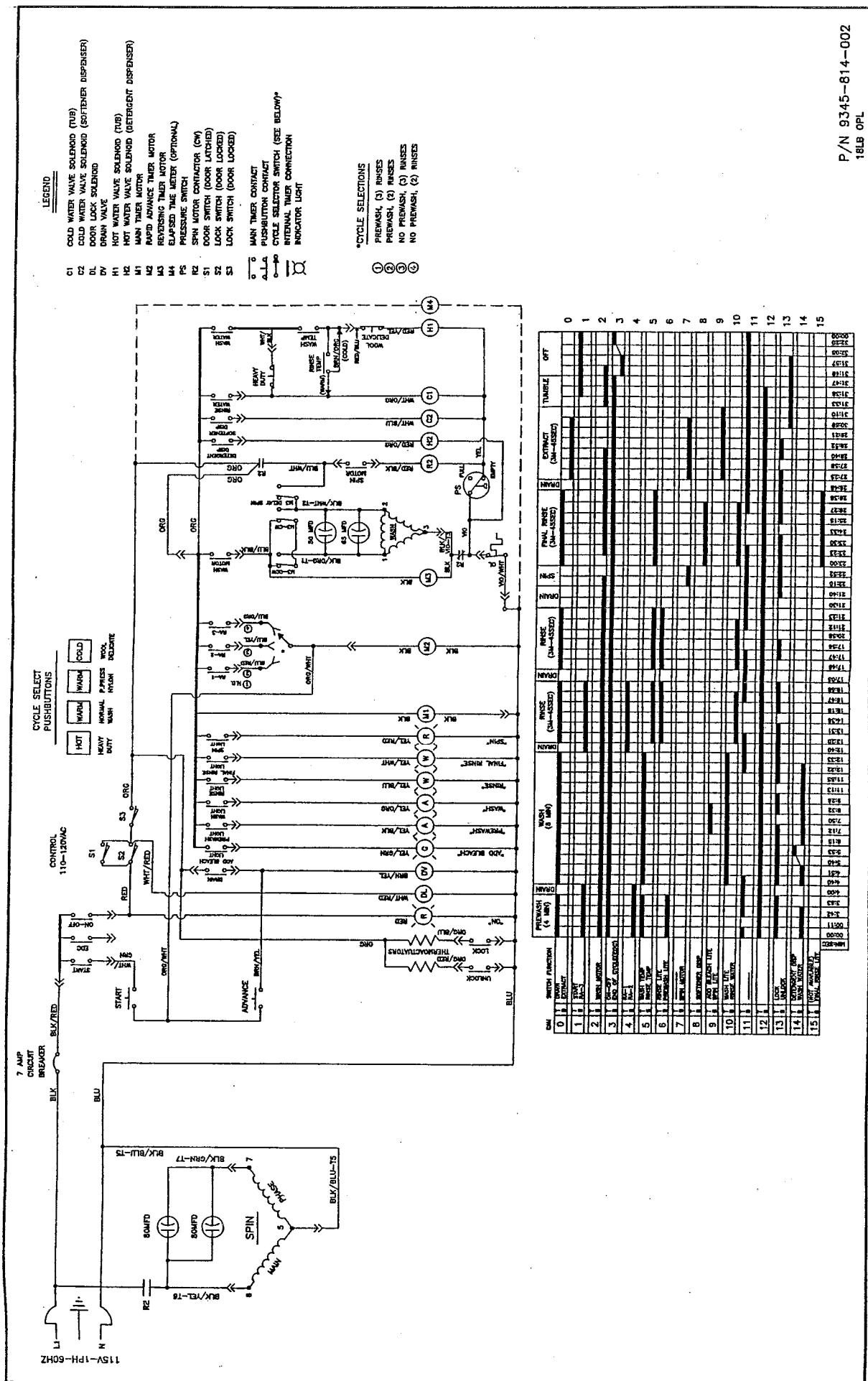

LEGEND

- C1 COLD WATER VALVE SOLENOID (TUB)
- C2 COLD WATER VALVE SOLENOID (SOFTENER DISPENSER)
- DL DOOR LOCK SOLENOID
- DV DRAIN VALVE
- H1 HOT WATER VALVE SOLENOID (TUB)
- H2 HOT WATER VALVE SOLENOID (DETERGENT DISPENSER)
- M1 MAIN TIMER MOTOR
- M2 REVERSE ADVANCE TIMER MOTOR
- M3 REVERSE ADVANCE TIMER MOTOR (OPTIONAL)
- PS PRESSURE SWITCH
- R1 SPIN MOTOR CONTACTOR (CM)
- R2 DOOR SWITCH (DOOR LATCHED)
- R3 LOCK SWITCH (DOOR LOCKED)
- R4 LOCK SWITCH (DOOR UNLOCKED)
- T1 MAIN TIMER CONTACT
- T2 PUSHBUTTON CONTACT
- T3 CYCLE SELECTOR SWITCH (SEE BELOW)
- T4 INTERNAL TIMER CONNECTION
- IL INDICATOR LIGHT

***CYCLE SELECTIONS**

- PREWASH (3) RINSES
- PREWASH (2) RINSES
- NO PREWASH, (3) RINSES
- NO PREWASH, (2) RINSES

P/N 9345-814-002
18LB OPL

| MIN | PREWASH (4 MIN) | WASH (10 MIN) | RINSE (30-55SEC) | EXTRACT (30-55SEC) | TUBBLE | OFF |
|-----|-----------------|---------------|------------------|--------------------|--------|-----|
| 0 | | | | | | |
| 1 | | | | | | |
| 2 | | | | | | |
| 3 | | | | | | |
| 4 | | | | | | |
| 5 | | | | | | |
| 6 | | | | | | |
| 7 | | | | | | |
| 8 | | | | | | |
| 9 | | | | | | |
| 10 | | | | | | |
| 11 | | | | | | |
| 12 | | | | | | |
| 13 | | | | | | |
| 14 | | | | | | |
| 15 | | | | | | |

WIRING SCHEMATIC 115V-1PH-60HZ

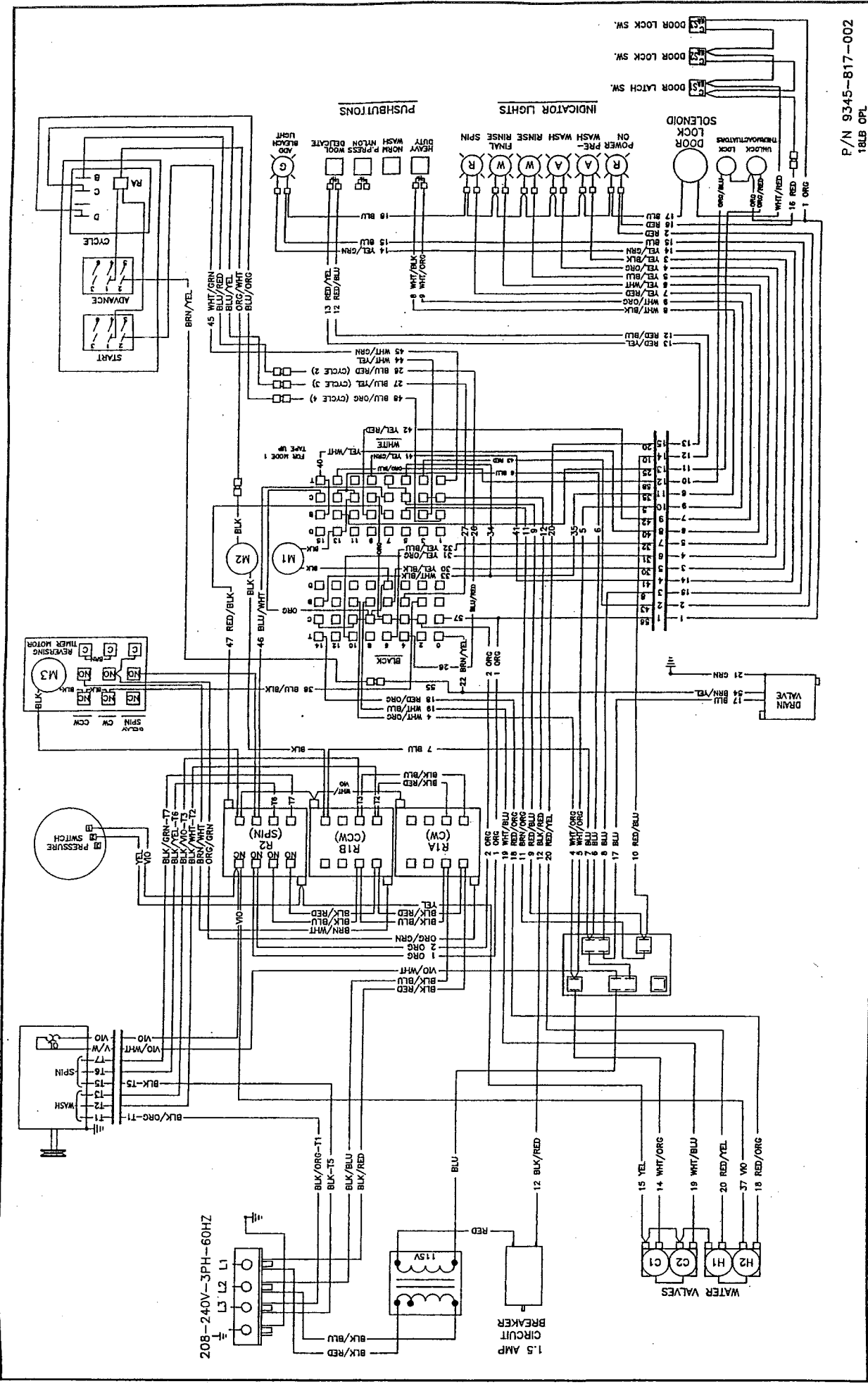

WIRING DIAGRAM 208-240V-3PH-60HZ

P/N 9345-817-002
18LB OPL

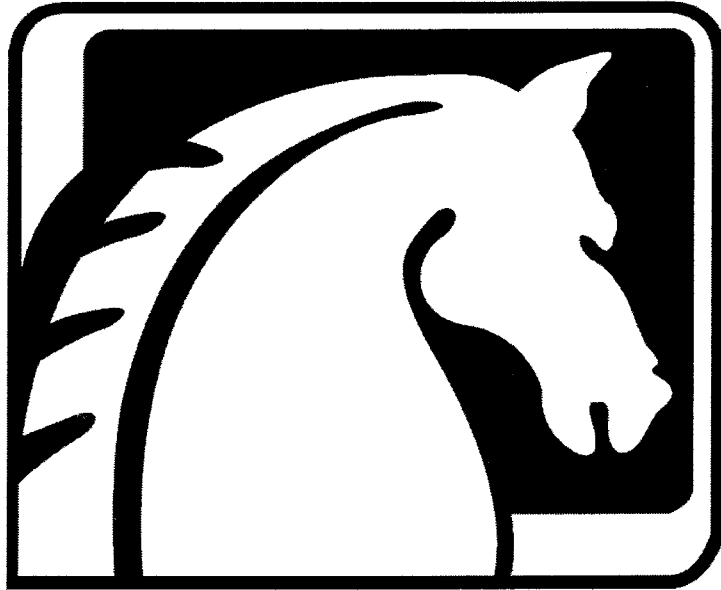

OPL MANUAL PARTS LIST

| Key | Part Number | Description | Qty. |
|-----|--------------|--------------------------------|------|
| 2 | 9532-140-010 | Primary Seal Vringa (opl epdm) | 1 |
| 3 | 9539-471-001 | Rotary Switch | 1 |
| 4 | 9539-474-001 | Rocker Switch Red | 1 |
| 5 | 9539-474-002 | Rocker Switch Wht. | 1 |
| 6 | 9452-595-001 | Switch Mounting Plate | 1 |
| 7 | 945-045-001 | Screws-8Bx1/4" | 6 |
| * | 8640-412-005 | Nuts Hex-keps 8/32 | 6 |
| * | 9627-674-001 | Wiring Harness OPL manual | 1 |
| * | 8220-001-235 | Wire Org./Wht. | 2 |
| * | 8220-001-377 | Wire Wht./Grn | 1 |
| 8 | 9307-176-001 | Knob | 1 |
| 9 | 8502-651-001 | Label Nameplate OPL | 1 |
| 10 | 8502-615-002 | Label Switch Mounting Plate | 1 |
| 11 | 9454-668-002 | Front Panel w/out coin box | 1 |
| * | 9345-814-002 | Wiring Schematic Single Phase | 1 |
| * | 9345-815-002 | Wiring Diagram Single Phase | 1 |
| | 9345-816-001 | Schematic Three Phase | 1 |
| | 9345-817-002 | Diagram Three Phase | 1 |



11

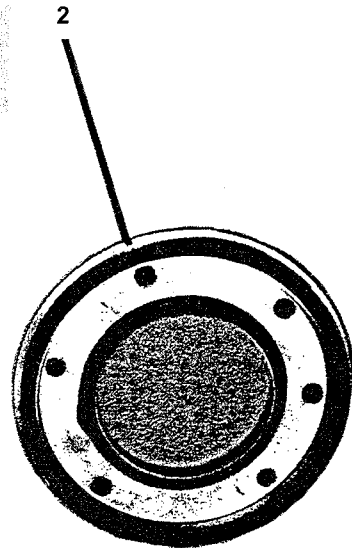

2

INSTRUCTIONS

- 1 Load clothes and close door securely.
- 2 Select CYCLE with rotary switch.
- 3 Select WASH TEMP with pushbutton.
- 4 Add detergent and softener.
- 5 Press START button.
- 6 Add bleach when green light is lit.

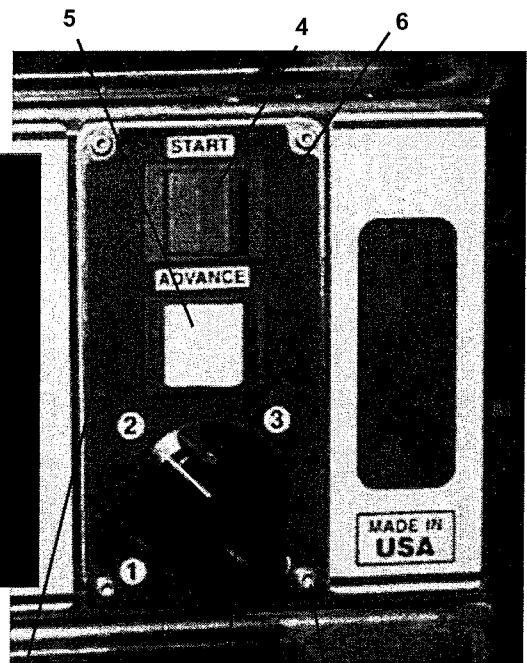

9

10

8 & 3

7

OPL Wiring Schematics

Timer Sequence Chart

The timer sequence charts are used in conjunction with the wiring diagrams to trace the circuitry during the timer cycle. The timer contacts and the operation or component that each contact controls are listed down the left side of the chart. The phases of the complete cycle are shown across the bottom of the chart. The timer switch increments are numbered across the top of the chart. The solid horizontal bars in the chart denote when the various contacts are closed during the cycle.

To use the timer sequence chart to trace the circuitry:

1. Locate the particular part of the cycle on the sequence chart.
2. Determine which timer contacts are closed during that particular step of the cycle by noting the solid vertical bars in that step across the chart.
3. Draw in the gap of the respective contacts on the wiring diagram with a soft dark pencil, to illustrate the contacts as being closed.
4. Similarly, determine which switch contacts are closed, by the switch chart, and illustrate them as closed on the wiring diagram.
5. The circuitry during the particular step of the cycle may then be easily traced on the wiring diagram, since all contacts and switches are then properly illustrated as being open or closed.

18lb. Washer Schematic

Start Circuit

Power travels into the machine on L1 & L2 (3 phase) or L1 & N (1 phase). On 3 phase, 240VAC goes to a Control Transformer that steps the voltage down to 120VAC for the controls. 120VAC then travels to the 1.5 amp Circuit Breaker. On 1 phase, 120VAC goes directly to the 7 amp Circuit Breaker. There is no need for a step down transformer.

From the Circuit Breaker, 120VAC travels on the black/red wire to the Main Timer Start and On-Off Contacts. The Start Contact is closed before the machine has been started so 120VAC travels through the Start Contact and is supplied to the Start switch. When the Start switch is closed a 120VAC signal is supplied on the orange/white wire to the Rapid Advance Timer Motor. This timer motor starts advancing the Main Timer to the preselected starting position. The On-Off Contact in the Main Timer closes and provides 120 VAC to the S1 Door Switch. The On-Off Contact also provides 120VAC to the On Light on the red wire. With the S1 Switch closed (door is latched) the Door Lock Solenoid is now powered with 120VAC via the white/red wire. The Door Lock Solenoid pulls in, locking the door and closing the S2 and S3 Switches. The S2 Switch is a backup to the S1 Switch so that the adjustment on S1 isn't as critical. The S3 Switch provides 120VAC to Timer Contacts RA-1,2, 3, or 4 to power the Rapid Advance Motor again and the Main Timer is allowed to advance on to the preselected start position based on which cycle number selected. The blue wire furnishes the neutral for the controls.

Fill Circuit-Warm

120VAC is supplied to the controls through the S1, S2, and S3 Door Switches. The On Light and the Door Lock Solenoid (discussed in Start Circuit) will remain on throughout the cycle as well as the Main Timer Motor. The Lock Thermoactuator Contact in the Main Timer is closed and provides the neutral side to operate the Lock Thermoactuator. This contact cycles open and closed keeping the Lock Thermoactuator activated until 1 1/2 minutes before the end of the cycle. At this point the contact opens and removes power to the Lock Thermoactuator. 120VAC is provided to the Lock Thermoactuator on the orange wire from the S3 Door Switch. The Drain Contact in the Main Timer is closed and provides 120VAC to the Drain Valve on the brown/yellow wire which closes the valve. The Wash Motor Contact in the Main Timer is closed and provides 120VAC to the Reversing Timer and the Reversing Timer Motor on the blue/black wire. This will start the Reversing Timer operating which will alternately open and close the Micro Switches that provide the direction of tumble for the wash basket. Depending on the cycle selected either the Wash Light Contact, the Prewash Light Contact, in the Main Timer is closed and provides 120VAC to these Lights. The orange wire coming from the S3 Door Switch provides power to the Wash Water Contact in the Main Timer. 120VAC connects from the Wash Water Contact to the Wash Temperature Contact via an internal timer connection.

Now a water temperature must be selected with the Temperature Selector Switch. We'll use #2 Warm Wash. The washer fills the tub through the back of the machine with both the C1 Cold and H1 Hot Water Valves. In the wash cycle, the detergent dispenser flushes the detergent into the tub. This is accomplished with the Wash Dispenser Contact in the Main Timer. 120VAC travels through the closed Wash Dispenser Contact and is supplied to the H2 Hot Water Valve Solenoid by the red/orange wire. As the washer fills with water, the Wash Basket will tumble one direction for 19 seconds, pause, and then reverse direction for 19 seconds. 120VAC travels from the Wash Water Timer Contact to the Heavy Duty Contact in the Selector Switch via the white/black wire. 120VAC goes through the closed Heavy Duty Contact in the Selector Switch and energizes the C1 Cold Water Valve Solenoid via the white/orange wire. 120VAC also travels to the closed Wool/Delicate Contact in the Selector Switch. This closed contact provides power to the H1 Hot Water Valve Solenoid via the red/yellow wire. When the water reaches the predetermined level the Pressure Switch moves to the full position and opens the neutral side of the line to the Water Valves. This shuts the Water Valves off.

Wash Circuit

As the washer fills the tub through the back of the machine with either one or both the C1 Cold and H1 Hot Water Valves, the Wash Basket will tumble one direction for 19 seconds, pause, and then reverse direction for 19 seconds. This is accomplished through the use of a Reversing Timer. 120VAC is supplied to the Reversing Timer Motor on the blue/black wire from the Wash Motor Timer Contact in the Main Timer. With 3 phase power, the Reversing Timer will alternately open and close the two Wash Micro Switches and provide 120VAC to the R1A (brown/white wire) and R1B (orange/green wire) Wash Contactor Coils. These coils open and close the Contactor Switches to operate the Drive Motor. With 1 phase power, there are no Wash Relays. 120VAC is provided directly to the motor by the Reversing Timer. 120 VAC on the black/orange wire is for counter clockwise and 120VAC on the black/white is for clockwise direction.

As discussed in Start and Fill, the Thermoactuator, Drain Valve, On Light, and Main Timer Motor are all operating throughout the Wash Cycle.

Drain, Rinse 1 & 2, & Final Rinse Circuit

The Drain Contact in the Main Timer opens removing power to the Drain Valve. The normally-open spring-loaded Drain Valve opens and empties the tub.

For Rinse 1 & 2, the Rinse Light Contact in the Main Timer closes and provides 120VAC to the Rinse Light. The Rinse Water Contact in the Main Timer also closes and provides 120VAC to the C1 Cold Water Solenoid. The tub will fill until the predetermined level is achieved at which time the Pressure Switch Contact will open the neutral side of the line shutting off the C1 Cold Water Solenoid.

For the Final Rinse, the Final Rinse Light Contact in the Main Timer closes and provides 120VAC to the Final Rinse Light. Rinse water is the same as in Rinse 1 & 2 above.

Extract Circuit

The Spin Contact in the Main Timer closes to provide 120VAC to the Spin Light. The Wash Motor Contact remains closed and provides 120VAC to the closed Clockwise Micro Switch on the Reversing Timer. 120VAC is then fed to the Counter Clockwise Micro Switch via a jumper wire. Power is then sent through the Counter Clockwise Micro Switch to the Delay Spin Micro Switch. The Delay Spin Micro Switch provides 120VAC to the Spin Motor Contact in the Main Timer on the blue/white wire. The Spin Motor Contact is closed for spin and the voltage continues on to the R2 Spin Motor Contactor Coil on the red/black wire. With 120VAC to the R2 Spin Motor Contactor Coil the Contactor is pulled down (closed) and two things happen. With the R2 Contactor closed, 120VAC is now provided from the orange wire directly to the Contactor eliminating the Reversing Timer and the Micro Switches from the circuit.

The second thing that happens when the R2 Contactor is closed is that voltage is provided directly to the Spin Winding in the motor on 3 phase machines and the washer spins.

On 1 phase washers, the R2 Contactor provides 120VAC to the Main Spin Winding and also provides 120VAC to the Spin Capacitors. The Spin Capacitors then provide 120VAC to the Phase Spin Winding.

Thermoactuator and Shake Out Circuit

The Lock Thermoactuator Contact in the Main Timer opens 1 1/2 minutes before the end of the cycle removing the neutral to the Thermoactuator. This allows the Thermoactuator time to retract by the end of the cycle.

To insure that the Lock Thermoactuator has retracted by the end of the cycle, 1 minute prior to the end of the cycle, the Unlock Thermoactuator is powered with 120VAC through the Unlock Thermoactuator Contact in the Main Timer.

The Spin Motor Contact in the Main Timer opens, stopping voltage to the R2 Spin Motor Relay & the motor. The basket will coast to a stop. The Wash Motor Contact in the Main Timer closes providing power to the Reversing Timer once again (discussed in Wash Cycle). The washer will tumble for approximately 30 seconds to let the clothes shake loose and then stop.

End of Cycle Circuit

The On-Off Contact in the Main Timer opens removing power to the Door Lock Switches and Contactors. The machine is now stopped. The Start Contact on the Main Timer is closed providing 120VAC to the Start switch on the wht/grn wire. The machine is now ready to start a new cycle.

Advance Cycle Switch

The Advance switch located on the front panel will allow the operator to advance through any step to the next drain. YOU CANNOT ADVANCE PAST A DRAIN. The main timer must control drain operation through the drain cycle. 120 VAC will come from the drain valve on the brn/yellow wire at the Advance switch (when switch is activated) to the org/wht wire to power the rapid advance timer through that step.

WASHER PREVENTIVE MAINTENANCE (PM) REQUIREMENTS

MAKE SURE ALL POWER IS DISCONNECTED BEFORE MAKING CHECKS INSIDE MACHINE.

DAILY

1. Clean the cabinet top around soap dispenser.
2. Clean the soap dispenser and soap lid and check that all dispenser mounting screws are in place and tight.
3. Check the drain for leaking and proper draining.
4. Check the water connections for leaks.
5. Check door seal for foreign material.
6. Leave the loading door open to aerate the washer when not in use.

QUARTERLY

1. Check the drive belt for wear and proper tension.
2. Clean lint and other foreign material from around drive motor.
3. Remove water inlet hose filter screens and clean or replace as necessary .
4. Check all electrical components for moisture and wipe away any foreign debris.

ANNUALLY

1. Clean and remove lint and foreign debris from outside cover of VFD with a dry clean rag or dry brush.
2. Inspect all wire connections especially at relays, terminal connections and circuit boards for tightness.
3. Inspect and check tightness of mounting bolts that mount washer frames to floor.

AFTER ANY SERVICE REINSTALL ALL PANELS AND SAFETY SCREENS BEFORE RECONNECTING POWER

