



# Section: 7

Parts Data

DC20X2

24VAC Control

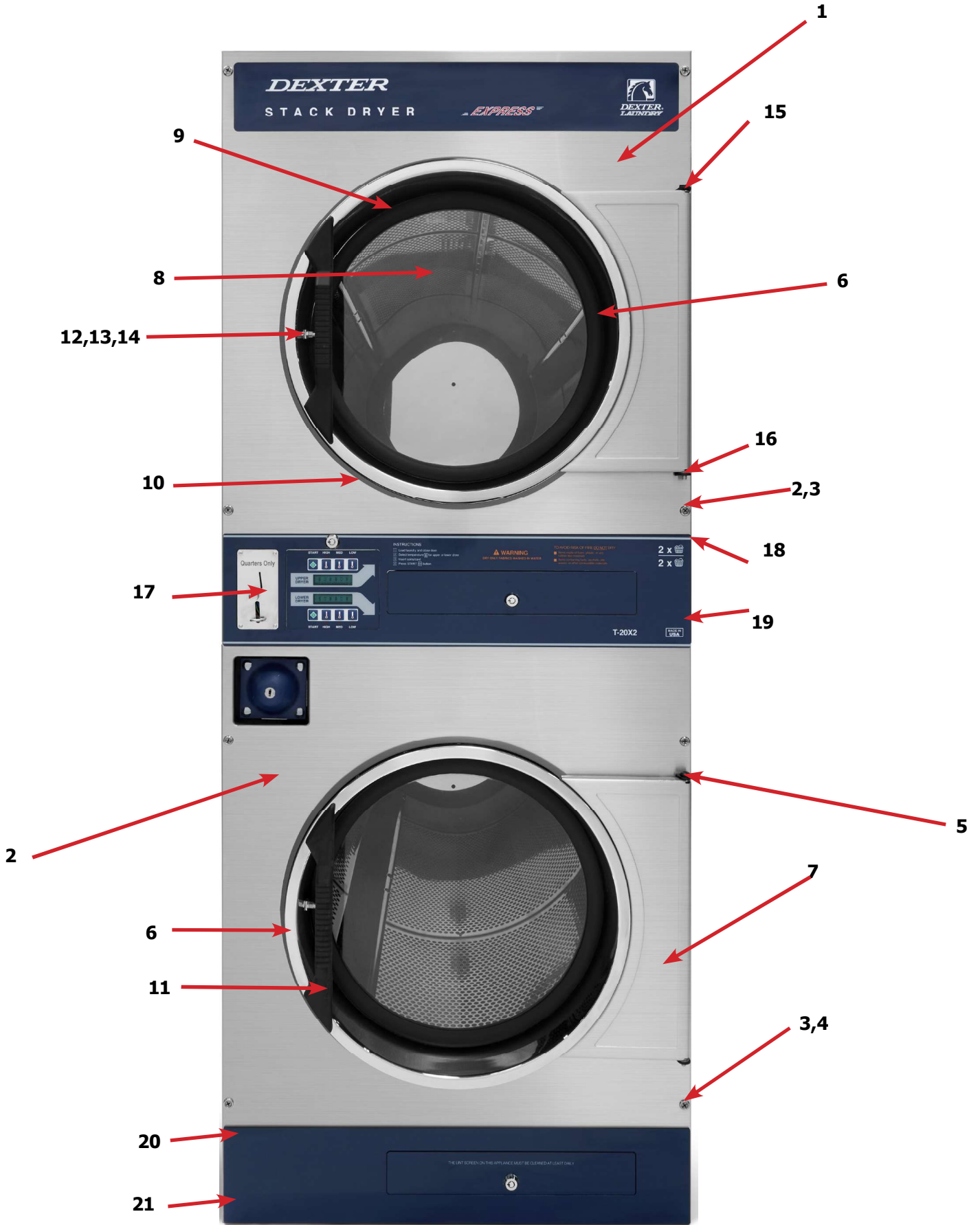

# Dryer Cabinet Group

| Key | Description                                     | T-20x2       | QTY |
|-----|---|--------------|-----|
| 1   | Panel Assy., Front- Upper (SS)                  | 9989-610-001 | 1   |
| 2   | Panelassy-front,coin(lower,ss                   | 9989-611-001 | 1   |
| *   | Insulation Front Panel, half moon (top)         | 9277-064-001 | 2   |
| *   | Insulation Front Panel, half moon (bottom)      | 9277-064-002 | 2   |
| 3   | Screw, FLHDCR, 10B x 1 3/4                      | 9545-008-014 | 8   |
| 4   | Washer, Finish, #10                             | 8641-585-001 | 8   |
| *   | Nut, Spring                                     | 8640-399-001 | 8   |
| *   | Hinge ,Backup Plate                             | 9982-392-001 | 2   |
| *   | Screw, Countersink, 10-32X 1/2                  | 9545-012-003 | 4   |
| 5   | Strap, Hinge (SS/Black)                         | 9544-074-002 | 2   |
| *   | Screw, Hinge to Panel                           | 9545-012-028 | 8   |
| 6   | Door Assy., Loading Complete-Chrome/BLK/SS      | 9960-315-002 | 2   |
| *   | Door Assy., Loading-Chrome (Ring Only)          | 9960-314-003 | 2   |
| 6   | Door Assy., Loading Complete-SS/BLK/SS          | 9960-315-001 | 2   |
| *   | Door Assy., Loading-SS (Ring Only)              | 9960-314-001 | 2   |
| 7   | Plate Assy., Hinge (SS)                         | 9982-393-001 | 2   |
| *   | Screw, Hinge to Door                            | 9545-012-015 | 8   |
| *   | Nut, Hinge to Door                              | 8640-413-002 | 8   |
| *   | Cover, Hinge Plate                              | 9074-377-002 | 2   |
| *   | Screw, Phillips-10B x 3/8                       | 9545-008-010 | 4   |
| 8   | Glass, Door                                     | 9212-002-005 | 2   |
| 9   | Gasket, Glass Black                             | 9206-413-003 | 2   |
| *   | Support, Door Glass                             | 9548-117-000 | 4   |
| *   | Tool Install Dryer Door Gasket                  | 8545-064-001 | 1   |
| 10  | Gasket, Outer Rim Black                         | 9206-420-006 | 2   |
| 11  | Handle, Loading Door                            | 9244-092-001 | 2   |
| *   | Screw, Handle 1/4-20 x 3/8                      | 9545-018-017 | 4   |
| 12  | Stud, Door Catch, 7/8                           | 9531-033-002 | 2   |
| 13  | Nut, Hex  | 8640-413-001 | 2   |
| 14  | Nut, Acorn                                      | 8640-413-003 | 2   |
| *   | Catch, Loading Door                             | 9086-015-002 | 2   |
| *   | Pop Rivet for mtg. catch                        | 8638-190-009 | 4   |
| 15  | Screw, Door to Hinge Strap (Special Black Type) | 9545-052-001 | 2   |
| 16  | Washer, Fiber                                   | 8641-436-003 | 2   |
| 17  | Acceptor, Coin                                  | 9021-092-002 | 1   |
| *   | Retainer, Coin Acceptor                         | 9486-149-001 | 2   |
| *   | Screw, 4Bx5/8ss, T10                            | 9545-053-002 | 4   |
| *   | Switch, Optical                                 | 9801-099-001 | 1   |
| 18  | Escutcheonassy-dry,coin,upr                     | 9994-043-001 | 1   |
| 19  | Overlay-esc,t-20x2,up,coin,blu                  | 9435-058-002 | 1   |
| *   | Overlay-esc,t-20x2,up,coin,black                | 9435-058-001 | 1   |
| *   | Screw, #4-40 x 3/16                             | 9545-020-009 | 23  |
| 20  | Escutcheonasy-dry,coin,opl,lwr                  | 9994-045-001 | 1   |
| 21  | Overlay-escut,t-20x2,lwr,blue                   | 9435-060-002 | 1   |
| *   | Overlay-escut,t-20x2,lwr,black                  | 9435-060-001 | 1   |

## Cabinet Group Continued

| Key | Description                                 | T20X2        | QTY |
|-----|---|--------------|-----|
| 22  | Nameplate Stack Dryer Express Blue          | 9412-251-002 | 1   |
| 22  | Nameplate Stack Dryer Express Black         | 9412-251-001 | 1   |
| 23  | Lint Drawer Assembly Blue                   | 9866-008-001 | 1   |
| 23  | Lint Drawer Assembly Black                  | 9866-008-003 | 1   |
| *   | Drawer, Front                               | 9974-016-002 | 1   |
| *   | Washer, Flat, #10                           | 8641-581-006 | 2   |
| *   | Washer, Curved-Spring                       | 8641-569-004 | 2   |
| *   | Nut, 10-32                                  | 8640-413-007 | 2   |
| 24  | Overlay Trim, Lint Drwr-Blue                | 9435-053-002 | 1   |
| 24  | Overlay Trim, Lint Drwr-Black               | 9435-053-001 | 1   |
| *   | Felt Seal (back of lint screen assembly)    | 9532-074-004 | 1   |
| *   | Lint Screen Assembly ONLY (no front)        | 9805-036-002 | 1   |
| *   | Replaceable Lint Screen Only                | 9555-057-011 | 1   |
| 25  | Lock and Key, Lint Drawer                   | 8650-012-004 | 1   |
| *   | Key 6101 only                               | 6292-006-010 | 1   |
| *   | Cam, Lock                                   | 9095-043-001 | 1   |
| *   | Lint Screen Strap Hold Down Screws 10Bx 1/4 | 9545-008-001 | 12  |
| 26  | Controls Assy, 24VAC, Blue                  | 9857-198-002 | 1   |
| 26  | Controls Assy, 24VAC, Black                 | 9857-198-004 | 1   |
| *   | Wireharness-main,dry,t-20x2                 | 9627-911-006 | 1   |
| 27  | Lock and Key, Control                       | 8650-012-003 | 1   |
| *   | Cam, Lock                                   | 9095-041-001 | 1   |
| *   | Washer-flat,shim                            | 8641-581-010 | 2   |
| *   | Washer-flat                                 | 8641-581-041 | 1   |
| *   | Key only 6324                               | 6292-006-007 | 1   |
| 28  | Sensor Temp Control                         | 9501-006-001 | 2   |
| *   | Wiringharness-heatsensor                    | 9627-855-003 | 1   |
| *   | Wire Nut Connector Grey                     | 8640-276-002 | 4   |
| 29  | Bracket-mtg,lintdrawerswitch                | 9029-297-001 | 2   |
| 30  | Switch-door,lowerservice                    | 9539-487-001 | 2   |
|     | Grommet-wire, 1/2 I.d"                      | 9209-089-001 | 2   |
|     | Plug-plastic,5/8"                           | 9456-041-010 | 2   |
|     | Screw-hxwshrhundct,#10bx1/2                 | 9545-008-026 | 4   |
| 31  | Cover, Cabinet (Top)                        | 9074-374-001 | 1   |
| *   | Insulation Cabinet Cover                    | 9277-041-028 | 1   |
| *   | Insulation-side Panel                       | 9277-041-027 | 2   |
| *   | Stack Dryer Trunion Puller                  | 8545-060-002 | 1   |
| 32  | Vault, Coin Box                             | 9942-038-005 | 1   |
| *   | Plateasy-coinvaultmounting                  | 9982-338-001 | 1   |
| *   | Screws, Mounting-Coin Vault                 | 9545-008-024 | 2   |
| 33  | Coin Box Assy, Large Blue                   | 9807-099-002 | 1   |
| 33  | Coin Box Assy, Large Black                  | 9807-099-004 | 1   |
| *   | Cabinet Touch Up Paint (White)              | 9472-001-013 | 1   |
| *   | Leg, Leveling 1/2"                          | 8544-006-001 | 4   |
| *   | Leveling Leg Wrench                         | 8545-061-002 | 1   |
| *   | Nut, Elastic Stop                           | 8640-413-004 | *   |

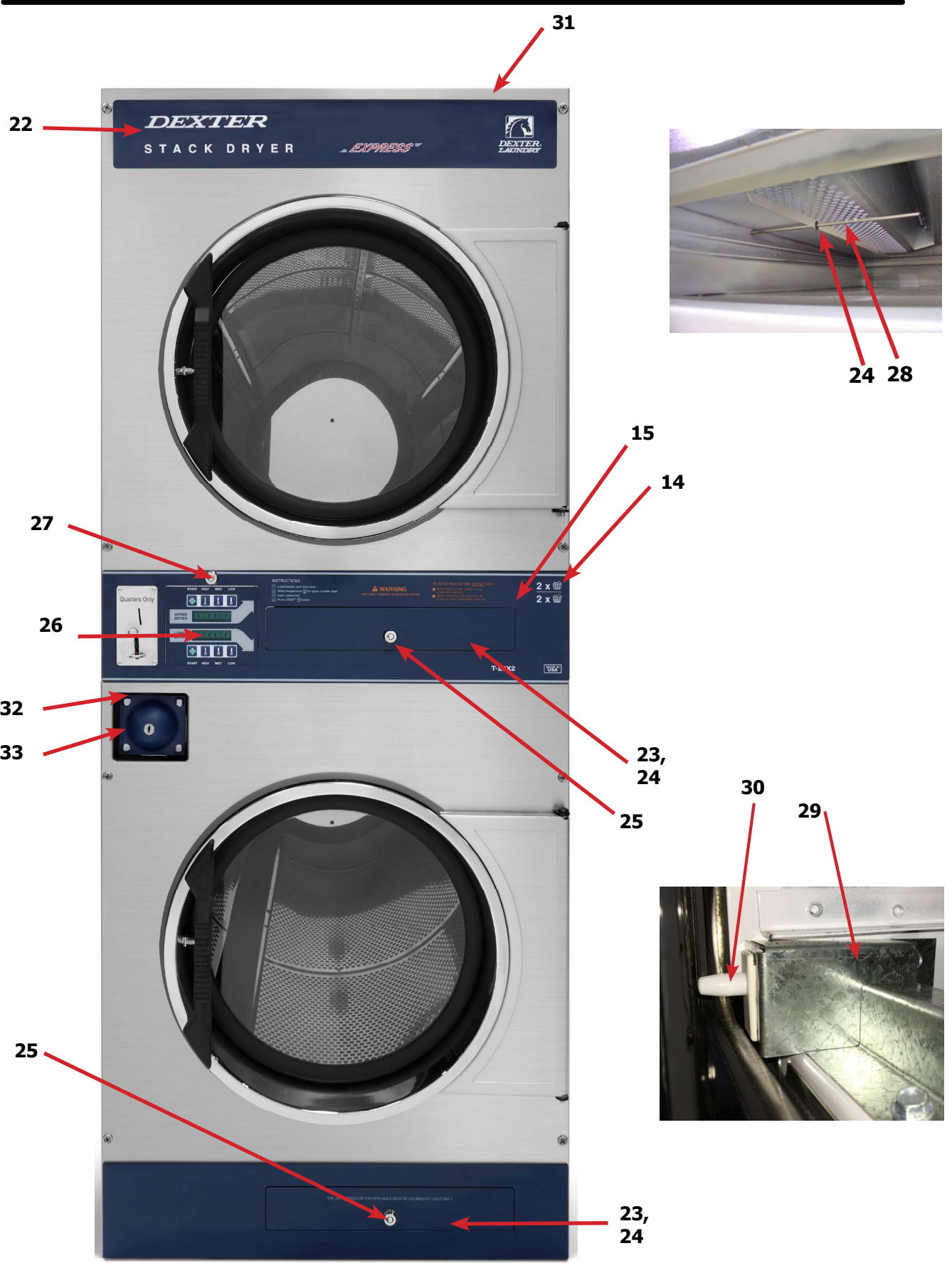

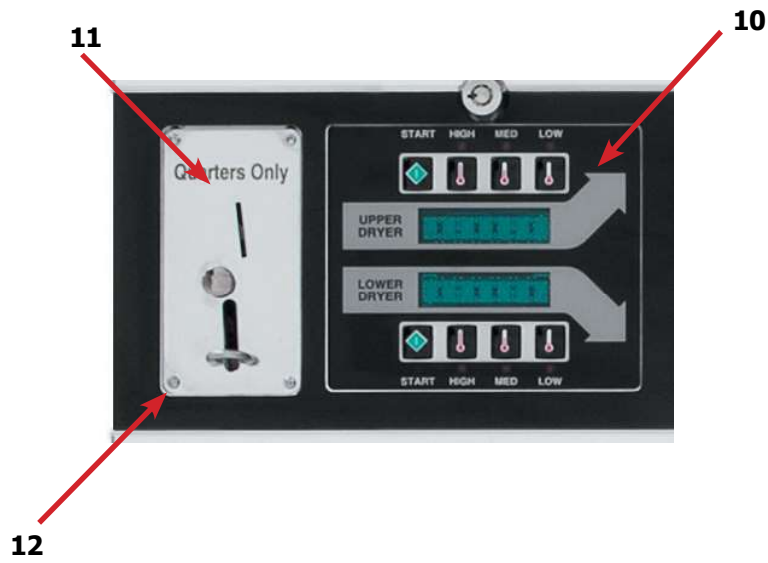
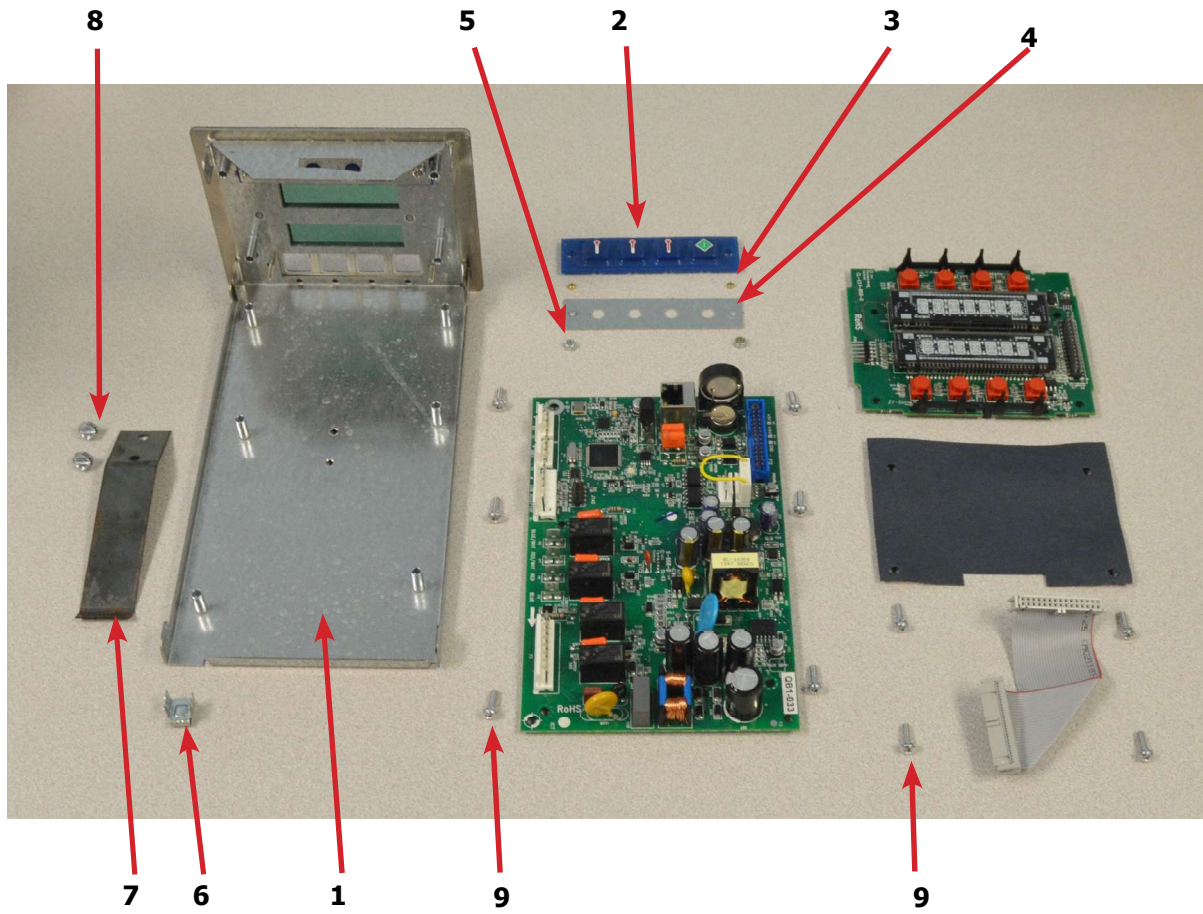

| Key | Description                        | Part Number  | Qty |
|-----|------------------------------------|--------------|-----|
| *   | Controls Assy, 24V, BLU            | 9857-198-002 | 1   |
| *   | Controls Assy, 24V, BLK            | 9857-198-004 | 1   |
| 1   | Trough Assembly                    | 9826-008-001 | 1   |
| 2   | Button-Push, Control, Black        | 9035-062-002 | 2   |
| 2   | Button-Push, Control, Blue...      | 9035-062-001 | 2   |
| 3   | Spacer-Metal, 4mm                  | 9538-166-011 | 4   |
| 4   | Retainer-Push Button               | 9486-158-001 | 2   |
| 5   | Nut-Hex, Elastic stop, #4-40       | 8640-424-002 | 4   |
| 6   | Terminal-Grounding clip            | 8652-130-038 | 1   |
| 7   | Spring-Flat, Control               | 9534-365-001 | 1   |
| 8   | Screw-Hex, #10B x 1/4              | 9545-008-001 | 2   |
| 9   | Screw-panhead 6-32 uncx 1/2        | 9545-044-010 | 10  |
| 9   | Washer-External tooth, #6          | 8641-582-005 | 10  |
| 10  | Overlay-Control, Coin, Black       | 9435-038-001 | 1   |
| 10  | Overlay-Control, Coin, Blue        | 9435-038-002 | 1   |
| 11  | Acceptor-Coin, Optical             | 9021-092-002 | 1   |
| *   | Retainer, Coin Acceptor            | 9486-149-001 | 1   |
| 12  | Screw                              | 9545-053-002 | 4   |
| *   | Optical Sensor, Replacement        | 9801-099-001 | 1   |
| *   | Wire Assy, Jumper, 30Lb Stack Coin | 8220-155-001 | 1   |
| *   | Wire Assy, Jumper, 50Lb Stack Coin | 8220-155-002 | 1   |
| *   | Wire Assy, Jumper, 20Lb Stack Coin | 8220-155-009 | 1   |

## Door Switch Group

| Key | Description                       | T-20x2       | QTY |
|-----|-----------------------------------|--------------|-----|
| 1   | Door Switches                     | 9539-487-001 | 2   |
| 2   | Bracket-Mounting lint tray switch | 9029-297-001 | 2   |
| 3   | Grommet Wire 1/2 i.d.             | 9029-089-001 | 2   |

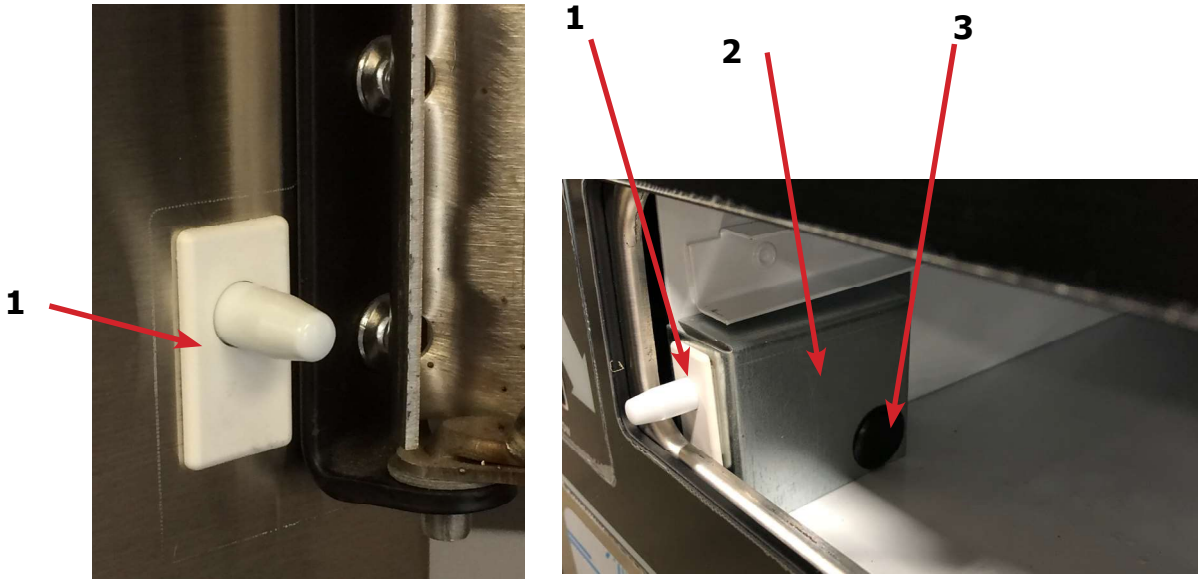

## Hinge Plate Cover

| Key | Description                    | T-20x2       | QTY |
|-----|--------------------------------|--------------|-----|
| 1   | Cover-Hinge, Black             | 9074-377-002 | 1   |
| 2   | Screw-TRHDCR, 10B x 3/8, Black | 9545-008-010 | 2   |

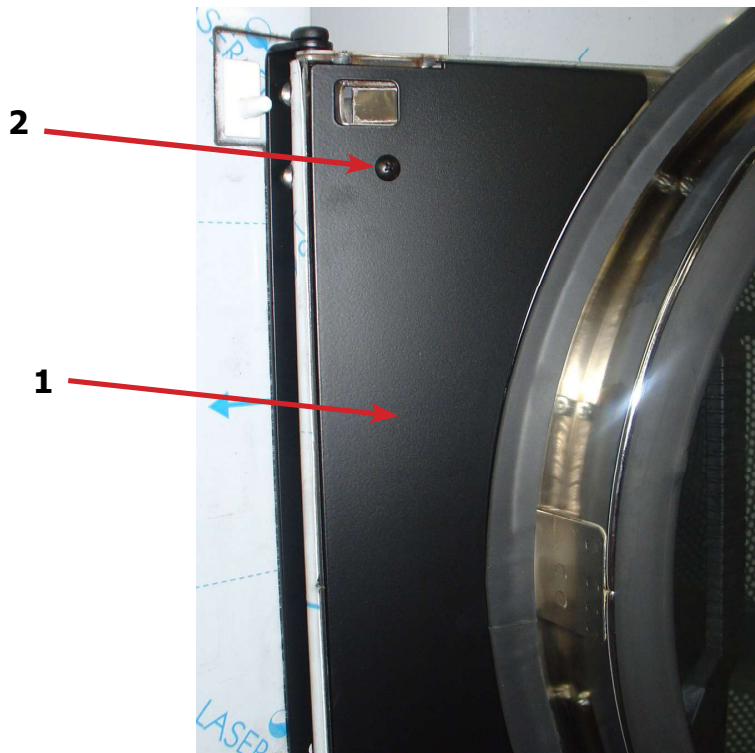





# Bearing Housing Group

| Key | Description  | T-20x2       | QTY |
|-----|--|--------------|-----|
|     | Bearing Housing Complete Assy (Includes bearings & Spacer) | 9803-160-003 | 2   |
| 1   | Housing, Bearing   | 9241-161-002 | 2   |
| *   | Spacer, Bearing  | 9538-139-002 | 2   |
| 2   | Bearing, Ball, Front & Rear                                | 9036-130-001 | 4   |
| 3   | Screw-Wizlock, 3/8-24x3/4                                  | 9545-049-002 | 8   |
| 4   | Nut, 5/16-18   | 8640-400-002 | 8   |
| 5   | Screw, 3/8-24x1  | 9545-049-001 | 4   |
| 6   | Nut, 3/8-24  | 8640-415-002 | 4   |

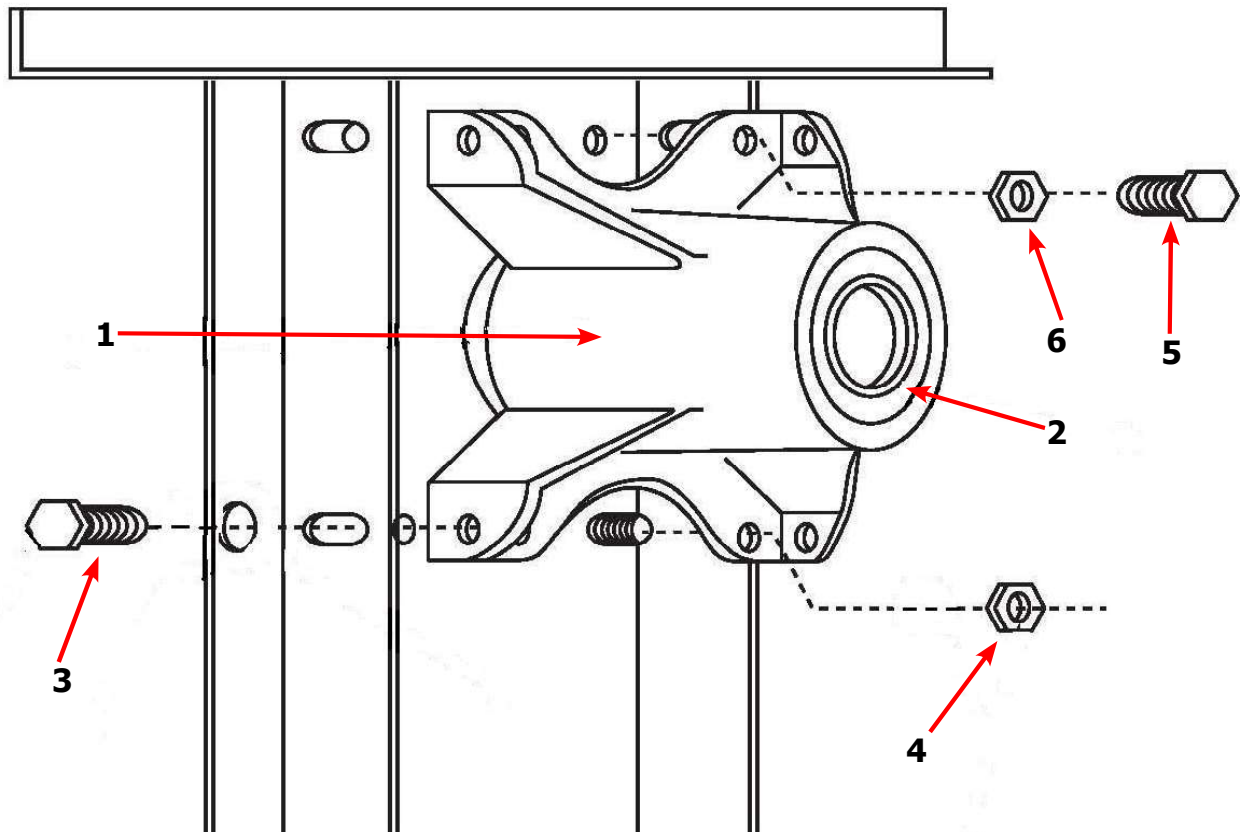
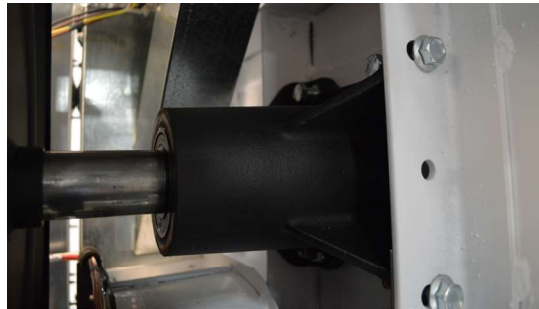

# Tumbler Group

| Key | Description                                      | T-20x2       | QTY |
|-----|--|--------------|-----|
| *   | Tumbler Assy Complete W/Spider (GALV)            | 9848-156-001 | 2   |
| 1   | Tumbler Assy (Galvanized)                        | 9848-155-001 | 2   |
| *   | Tumbler Assy Complete W/Spider (SS & Galv front) | 9848-156-002 | 2   |
| 1   | Tumbler Assy (Stainless Galvanized front)        | 9848-155-002 | 2   |
| 2   | Rod, Tumbler                                     | 9497-019-004 | 6   |
| 3   | Washer, Special                                  | 8641-554-001 | 6   |
| 4   | Shim   | 9552-013-003 | AR  |
| 5   | Spider Assy                                      | 9568-018-001 | 2   |
| 6   | Nut, Wiz Lock                                    | 8640-415-004 | 6   |
| 7   | Spacer-Shaft                                     | 9538-164-001 | 2   |
| 8   | Tolerance Ring                                   | 9487-234-005 | 2   |
| 9   | Pulley, Driven                                   | 9908-052-002 | 2   |
| 10  | Washer -Flat 1/2                                 | 8641-581-026 | 2   |
| 11  | LockWasher - IntTooth, 1/2"                      | 8641-582-016 | 2   |
| 12  | Screw, 1/2-13x1 1/4                              | 9545-017-009 | 2   |
| *   | Belt, Drive                                      | 9040-073-013 | 2   |

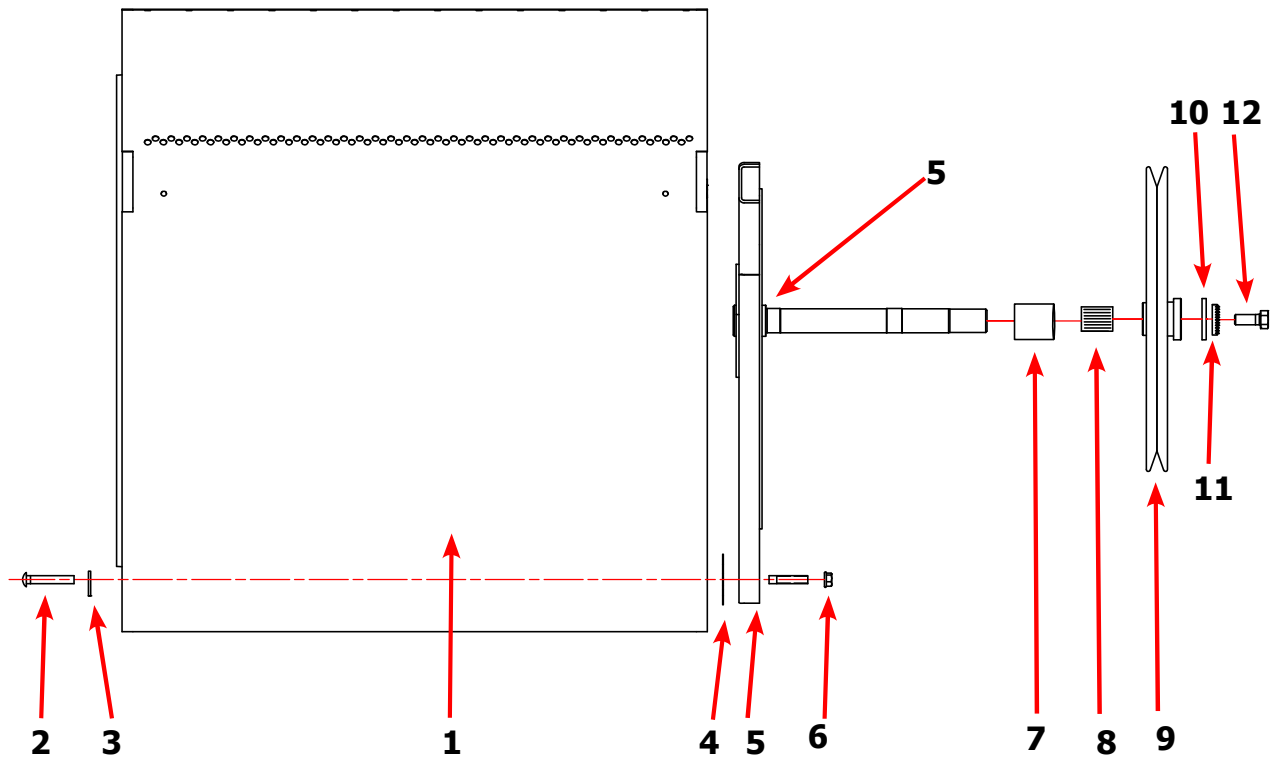

# Dryer Burner Housing Group

| Key | Description   | T-20X2       | QTY |
|-----|---|--------------|-----|
| *   | Housing Assembly, Burner (All sheet metal parts not listed) Upper | 9803-221-001 | 1   |
| *   | Cover Burner upper  | 9074-373-001 | 1   |
| *   | HOUSING ASSEMBLY - BURNER, LOWER                                  | 9803-221-002 | 1   |
| 1   | Panel, Back Burner Housing  | 9454-949-001 | 2   |
| 2   | Screw, 10B X 1/4"   | 9545-008-001 | 8   |
| 3   | Angle, Burner Support   | 9003-220-001 | 2   |
| *   | Screw, 10B x 3/8"   | 9545-008-006 | 4   |
| 4   | Burner, Main  | 9048-023-001 | 4   |
| *   | Screw 10AB x 3/8"   | 9545-008-006 | 4   |
| 5   | Electrode-ignition  | 9875-002-003 | 2   |
| 6   | Screw, Electrode Mtg 8B x 1/4"                                    | 9545-045-001 | 4   |
| 7   | Pipeassembly-gas,t-20x2   | 9838-018-004 | 2   |
| 8   | Control Assy, Gas   | 9857-134-001 | 2   |
| 9   | Wireasy-yel,47/8"   | 8220-001-466 | 2   |
| 10  | Manifold, Assy  | 9381-012-001 | 2   |
| *   | Orifice, Burner-Natural #40                                       | 9425-069-030 | 4   |
| *   | Orifice, Burner-LP #54  | 9425-069-031 | 2   |
| 11  | Bracket, Manifold   | 9029-305-001 | 2   |
| 12  | Pipe Plug in end of Burner Manifold                               | 8615-104-045 | 2   |
| *   | Screw, 10AB x 3/8"  | 9545-008-006 | 4   |
| 13  | Bracket, High Limit Thermostat                                    | 9029-192-001 | 2   |
| 14  | Thermostat, Hi-Limit  | 9576-203-002 | 2   |
| *   | Spacer, Hi-Limit  | 9538-142-001 | 4   |
| *   | Screw 8B x 3/4"   | 9545-045-007 | 4   |
| 15  | Cover, Hi-Limit Stat  | 9074-329-001 | 2   |
| *   | Screw, 10AB x 3/8"  | 9545-008-006 | 4   |
| 16  | Thermostat, Safety Shutoff  | 9576-207-006 | 2   |
| 17  | Screw, 10AB x 3/8"  | 9545-008-006 | 4   |
| *   | Control, Ignition Fenwall (3 trybox)                              | 9857-182-001 | 2   |
| *   | Kit, LP Conversion 20Lb Stack Kit                                 | 9732-102-034 | 2   |

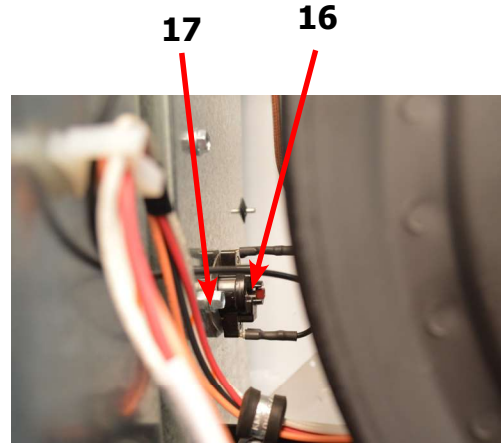
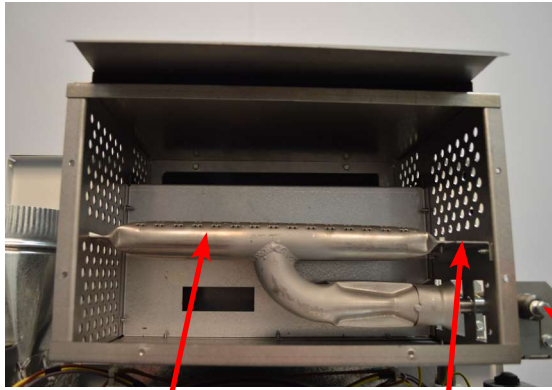
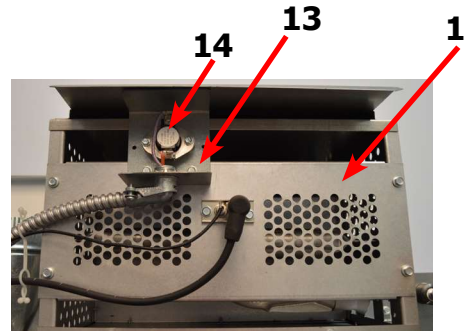
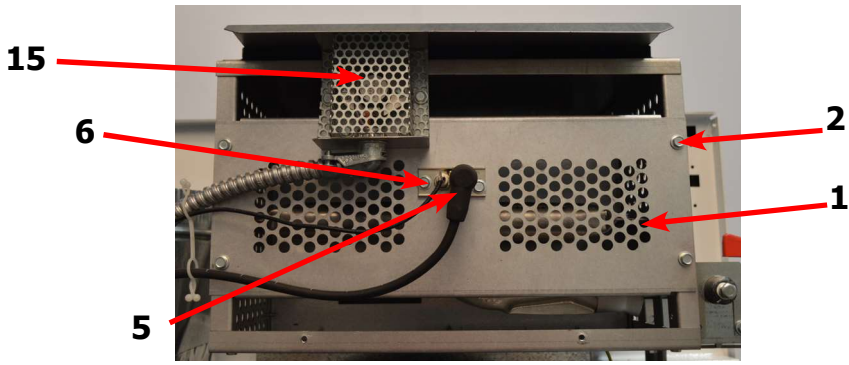

12

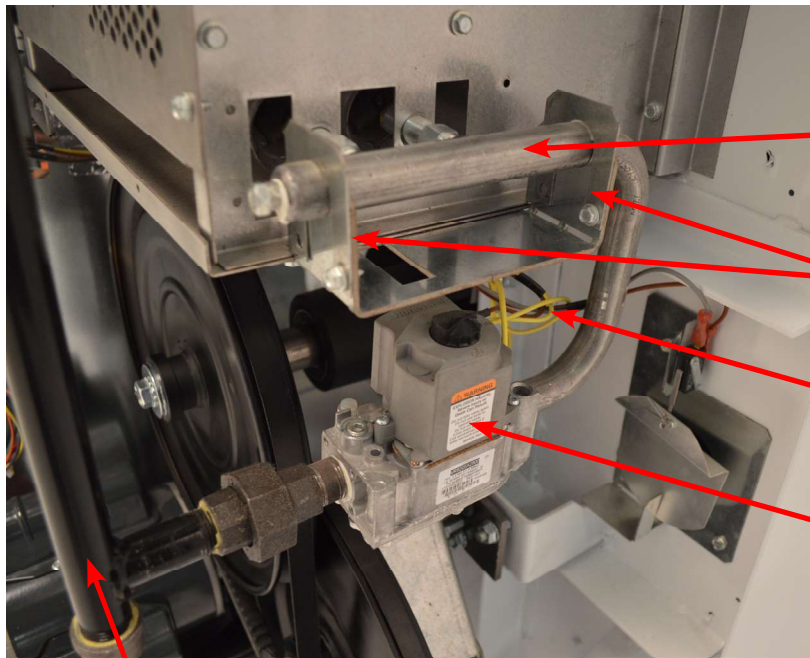

7

| Key | Description  | T-20x2       | QTY |
|-----|--|--------------|-----|
| *   | Switch Assy, Air Flow                              | 9801-095-001 | 2   |
| 1   | Switch, Air Flow                                   | 9539-461-009 | 2   |
| 2   | Bracket, Switch- Air Flow                          | 9029-174-001 | 2   |
| 3   | Actuator, Switch                                   | 9008-007-001 | 2   |
| 4   | Pin, Cotter  | 9451-169-002 | 2   |
| 5   | Screw 4-40 x 5/8"                                  | 9545-020-001 | 4   |
| *   | Nut, Special Twin .#4-40                           | 8640-401-001 | 2   |
| *   | Shield, Switch                                     | 9550-169-003 | 2   |
| *   | Screw 10 Bx 1/4"                                   | 9545-008-001 | 3   |
| 6   | Motor, Drive                                       | 9376-332-001 | 2   |
| *   | Run Capacitor                                      | 5191-108-004 | 2   |
| *   | Start Capacitor                                    | 5191-109-004 | 2   |
| *   | Pulley-motor,60hz                                  | 9453-185-001 | 2   |
| *   | Screw-set,5/16-18x1/2                              | 9545-028-013 | 2   |
| 7   | Plate, Motor Mtg                                   | 9982-390-002 | 2   |
| 8   | Screw, Motor to Plate Screw-hxflgwhzlk,5/16-18x5/8 | 9545-014-004 | 8   |
| *   | Nut-hextwinwhzlk,5/16-18                           | 8640-400-003 | 8   |
| 9   | Nut 1/4x20 Motor Plate to Cabinet                  | 8640-414-007 | 14  |
| 10  | Clamp-cable,3/4                                    | 8654-125-004 | 4   |
| *   | Screw-hxhdsldtmach,12abx1/2                        | 9545-048-001 | 4   |
| 11  | SupportAssy, Intermed. Pulley                      | 9991-053-002 | 2   |
| 12  | Bolt, Rd Hd 3/8-16 x 1 1/4                         | 9545-029-010 | 6   |
| 13  | Bolt, 3/8-16 x 1 1/2                               | 9545-029-012 | 2   |
| 12  | Nut Flange Wiziock 3/8" - 16                       | 8640-415-004 | 6   |
| *   | Washer, Flat                                       | 8641-581-035 | 2   |
| 14  | Arm Assy-Tension, Complete                         | 9861-022-001 | 2   |
| *   | Washer, Flat                                       | 8641-581-035 | 4   |

# Rear View Photos

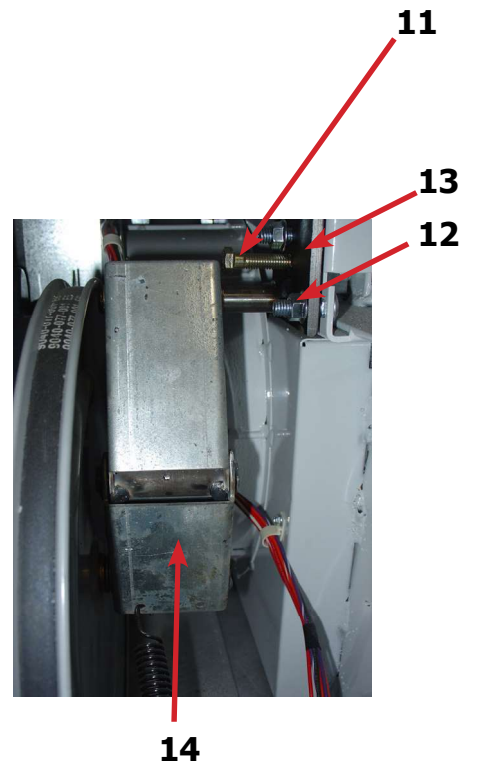
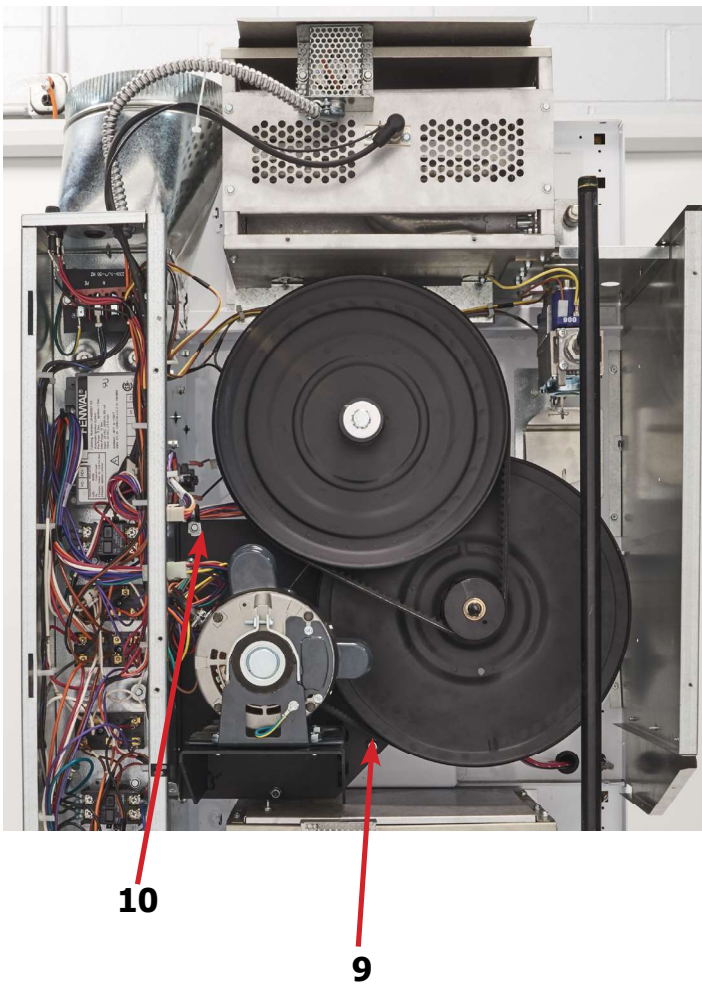
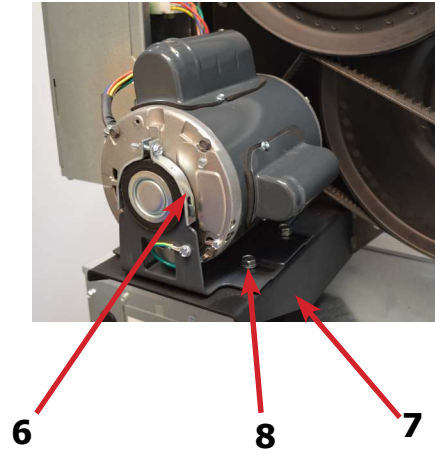
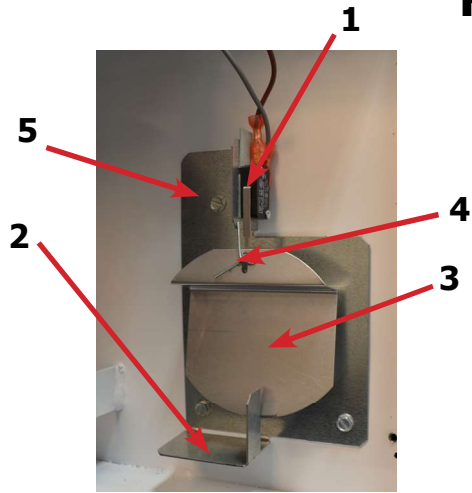

| Key | Description  | T-20x2       | QTY |
|-----|--|--------------|-----|
| 14  | Arm Assy-Tension, Complete                           | 9861-022-001 | 2   |
| *   | Washer, Flat   | 8641-581-035 | 6   |
| 15  | Ring-Retaining                                       | 9487-200-003 | 6   |
| 16  | Pulley Assy, Intermediate with bronze flange bearing | 9908-053-003 | 2   |
| *   | Bearing - Bronze Flange                              | 9036-145-002 | 2   |
| *   | Spacer-Shaft (See Tumbler Group for Expanded View)   | 9538-164-001 | 2   |
| *   | Tolerance Ring                                       | 9487-234-005 | 2   |
| 17  | Pulley, Driven                                       | 9908-052-002 | 2   |
| 18  | Washer -Flat   | 8641-581-026 | 2   |
| 18  | LockWasher - IntTooth, 1/2"                          | 8641-582-016 | 2   |
| 18  | Screw, 1/2-13x1 1/4                                  | 9545-017-009 | 2   |
| 19  | Belt, Drive- Motor                                   | 9040-076-012 | 2   |
| 20  | Belt, Drive- Tumbler                                 | 9040-073-013 | 2   |
| 21  | Spring, Tension                                      | 9534-319-002 | 2   |
| 22  | Chain, Tension                                       | 9099-012-011 | 2   |
| 23  | Hook, Tension  | 9248-022-002 | 2   |
| *   | Damper Inside Duct Exhaust                           | 9125-009-001 | 2   |
| 24  | Pin, Damper Hinge                                    | 9451-146-007 | 2   |
| *   | Box-duct.lower                                       | 9041-113-001 | 1   |
| *   | Nut, Spring  | 8520-141-000 | 4   |
| *   | Screw #10B x 1/2                                     | 9545-008-026 | 4   |
| *   | Cover Duct Upper                                     | 9074-382-001 | 1   |
| *   | Base Duct  | 9047-121-001 | 1   |
| *   | Screw 10ABx 3/8"                                     | 9545-008-024 | 40  |
| 26  | Impeller, W/Set Screws                               | 9278-045-001 | 2   |
| 27  | Pulley, Motor  | 9453-185-001 | 2   |
| 28  | Bracket for Wire Harness Under Burner Housing        | 9029-291-001 | 2   |



# Rear View Photos

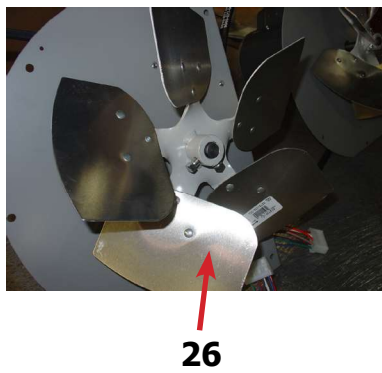
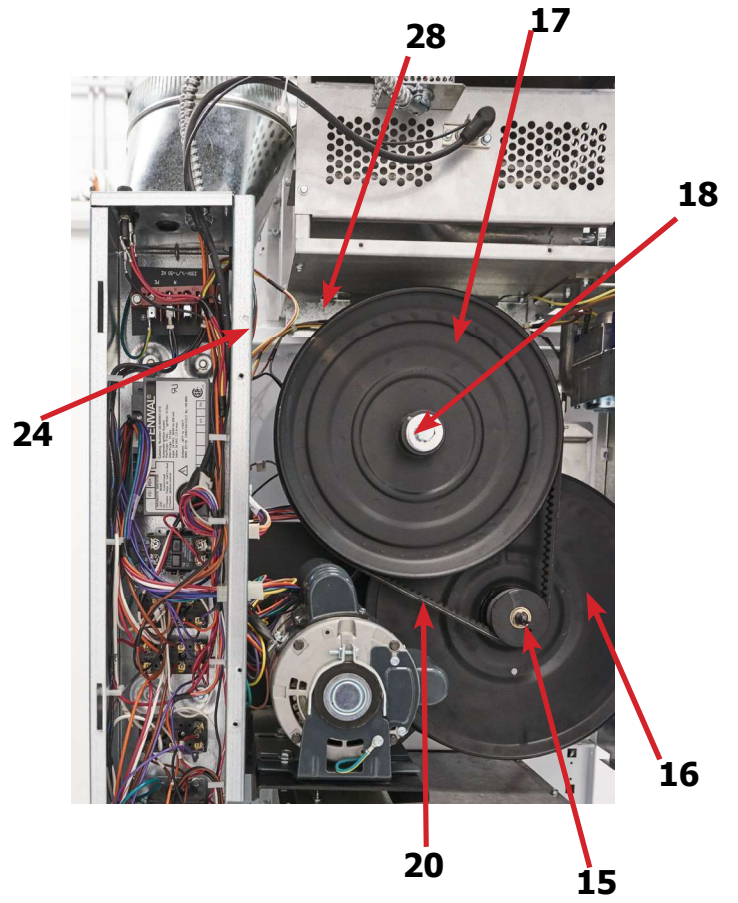
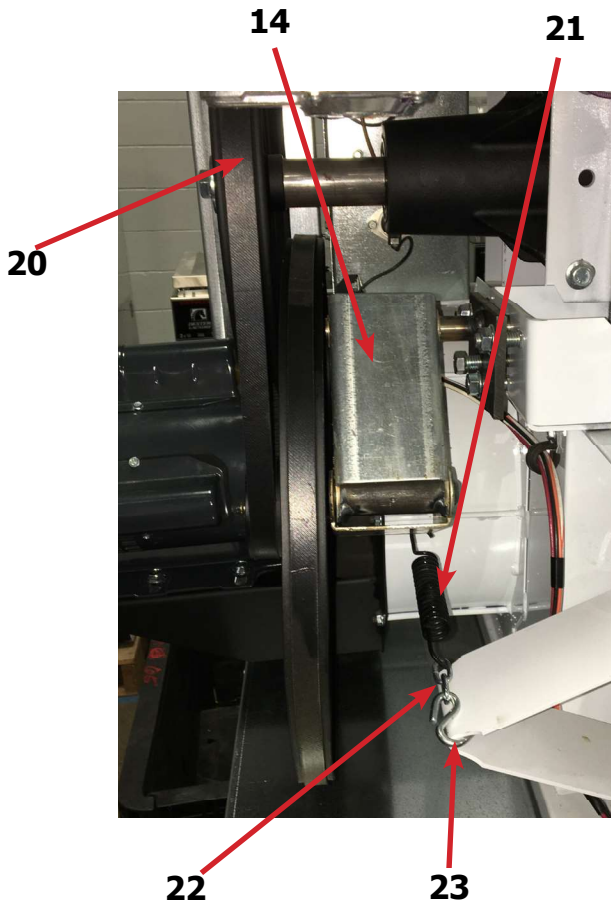

# Dryer Back Panels and Guards

| Key | Description                             | Part Number  | Qty |
|-----|---|--------------|-----|
| 1   | Guard, Drive                            | 9208-144-001 | 2   |
| 2   | Screw, 10AB x 3/8                       | 9545-008-024 | 39  |
| 3   | Panel, Drive Guard,                     | 9208-131-001 | 3   |
| 4   | Guard-Small, upper                      | 9208-134-001 | 1   |
| 5   | Guard-Small,lower                       | 9208-143-001 | 1   |
| 6   | Guard-side,lower                        | 9208-132-001 | 2   |
| 7   | Warning, Label                          | 8502-763-001 | 1   |
| 8   | Label, Instructions                     | 8502-645-001 | 1   |
| 9   | Lighting and Clearance, Label           | 8527-112-001 | 1   |
| 10  | Duct, Transition                        | 9109-131-001 | 1   |
| 11  | Door, Cover-Control Box                 | 9108-146-001 | 1   |
| *   | Screw-hxwshrundrcuthd,10abx3/8          | 9545-008-024 | 3   |
| 12  | Cabinet, Cover                          | 9074-374-001 | 1   |
| *   | Insulation                              | 9277-041-028 | 1   |
| *   | Wiring Diagram & Schematic              | 9506-836-001 | 1   |
| 13  | Bracket-back Panel                      | 9029-211-001 | 1   |
| *   | Screw, 10AB x 3/8                       | 9545-008-024 | 2   |
| 14  | Label-quality                           | 8511-001-002 | 1   |
| 15  | Cover-hi Limit                          | 9074-329-001 | 2   |
| 16  | Housingassy-burner,upper                | 9803-221-001 | 1   |
| 17  | Housingassy-burner,lower                | 9803-221-002 | 1   |
| 18  | Cover-duct,lower                        | 9074-383-001 | 1   |
| *   | 8" Slide Open Clean Out Duct (Optional) | 9973-034-001 | 1   |

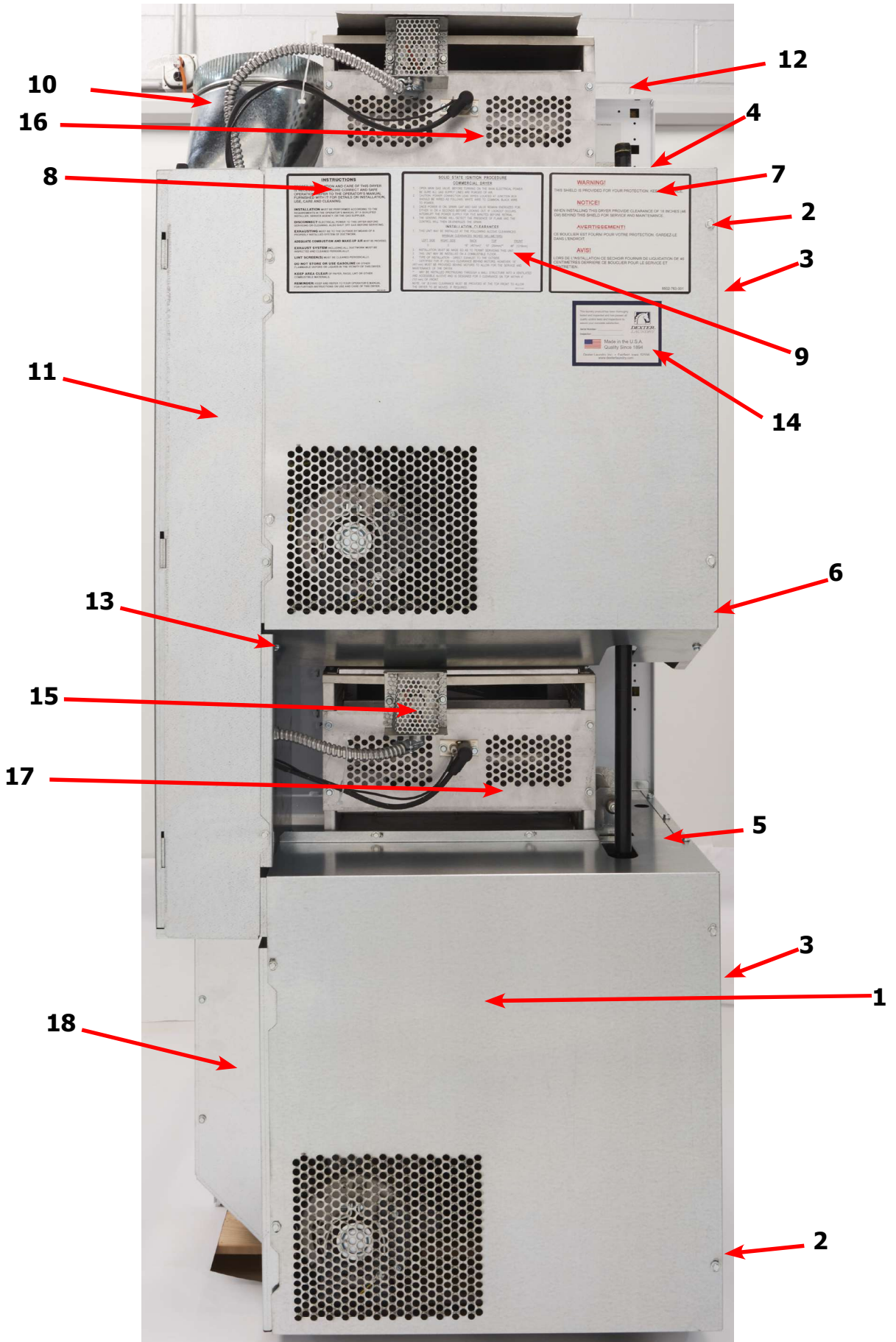

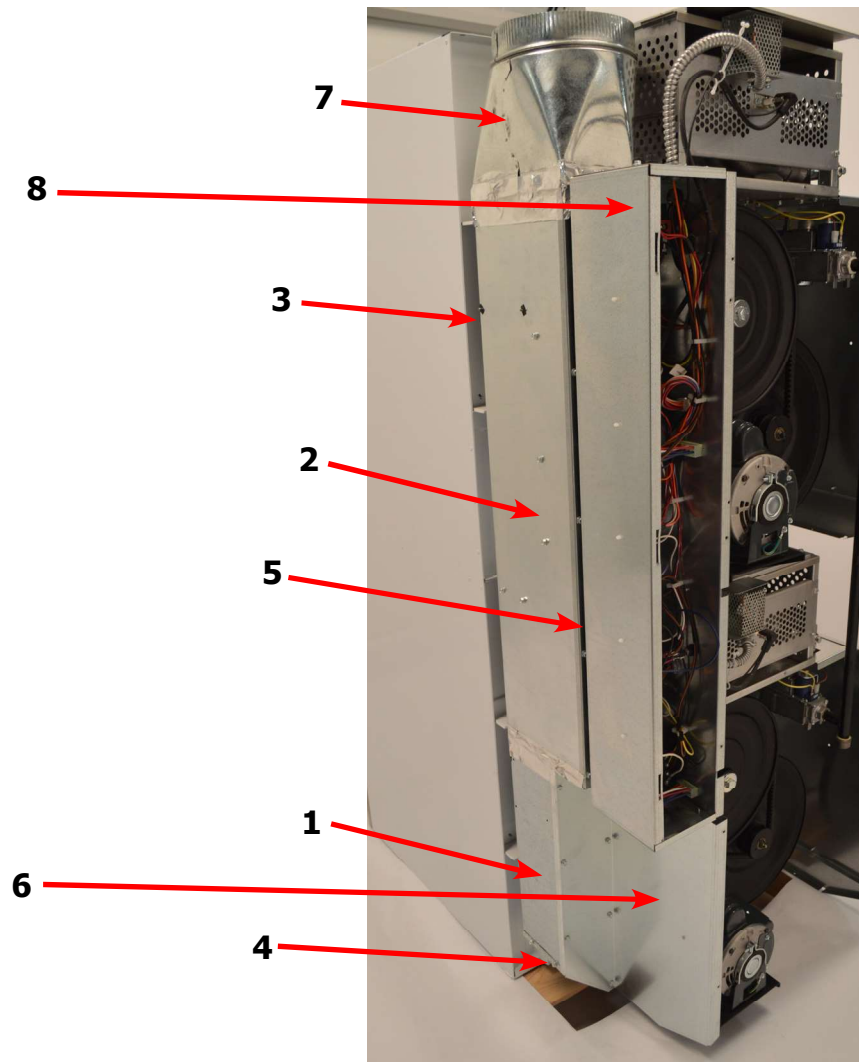

| Key | Description                    | T-20x2       | QTY |
|-----|--------------------------------|--------------|-----|
| 1   | Box-duct.lower                 | 9041-113-001 | 1   |
| 2   | Box-duct,upper                 | 9041-115-001 | 1   |
| *   | Screw-hxwshrhdundct,#10bx1/2   | 9545-008-026 | 8   |
| *   | Baffle-duct                    | 9049-117-001 | 1   |
| *   | Deflector-duct                 | 9114-054-001 | 1   |
| 3   | Damper-duct                    | 9125-009-001 | 2   |
| *   | Pin-hinge,damper               | 9451-146-007 | 2   |
| *   | Nut-spring                     | 8520-141-000 | 4   |
| *   | Screw-hxwshrhdundct,#10bx1/2   | 9545-008-026 | 4   |
| *   | Gasket-exhaust,1/8x1/4         | 9206-428-002 | 1   |
| 4   | Base-duct                      | 9047-121-001 | 1   |
| 5   | Cover-duct,upper               | 9074-382-001 | 1   |
| 6   | Cover-duct,lower               | 9074-383-001 | 1   |
| 7   | Duct-transition                | 9109-131-001 | 1   |
| *   | Screw-hxwshrundrcuthd,10abx3/8 | 9545-008-024 | 59  |
| 8   | Cntlasy-ign,t-20x2,gas,coin-15 | 9857-250-001 | 1   |

# Air Flow Switch Assembly

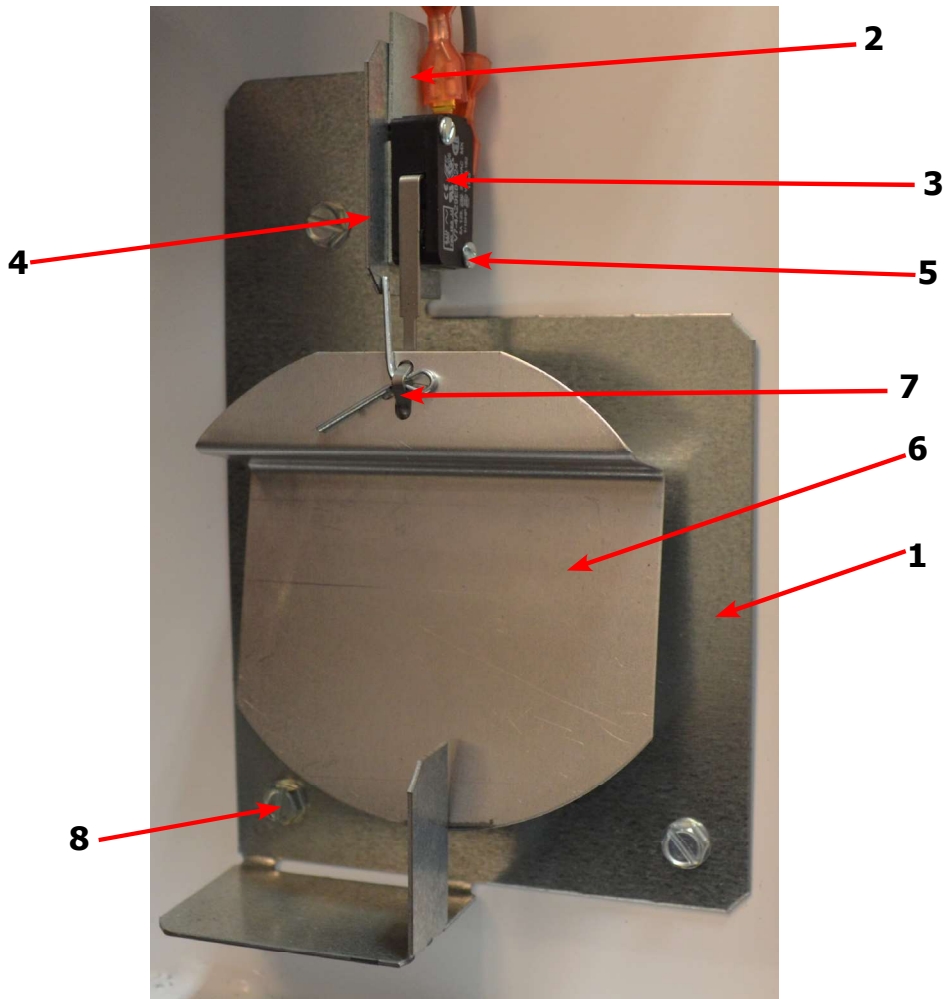

| Key | Description              | T-20x2       | QTY |
|-----|--------------------------|--------------|-----|
| *   | Air Flow switch Assy     | 9801-095-001 | 2   |
| 1   | Bracket-Airflow switch   | 9029-174-001 | 2   |
| 2   | Shield-Switch            | 9550-169-003 | 2   |
| 3   | Switch-Micro             | 9539-461-009 | 2   |
| 4   | Nut-Twin, 4-40           | 8640-401-001 | 2   |
| 5   | Screw-.625, 4-40         | 9545-020-001 | 2   |
| 6   | Actuator-Air Flow Switch | 9008-007-001 | 2   |
| 7   | Pin-Cotter, .09375x.75   | 9451-169-002 | 2   |
| 8   | Screw, 10 B x 1/4        | 9545-008-001 | 3   |
| *   | Wireasy-brn,#13,34"      | 8220-063-032 | 1   |
| *   | Wireasy-org,#14,24"      | 8220-095-040 | 1   |
| *   | Wireasy-vio,54"          | 8220-103-001 | 1   |

| Key | Description                           | T-20X2       | QTY |
|-----|---------------------------------------|--------------|-----|
| *   | Control, Rear                         | 9857-250-001 | 1   |
| 1   | Wrapper-controlbox                    | 9636-219-001 | 1   |
| 2   | Panel-upper,controlbox                | 9454-974-001 | 1   |
| 3   | Panel-lower,controlbox                | 9454-973-001 | 1   |
| *   | Screw-hxwshrundrcuthd,10abx3/8        | 9545-008-024 | 6   |
| 4   | Wireasy-grn/yel,7"                    | 8220-137-002 | 1   |
| *   | Screw-hxwsrhds1,10-32tx1/2grn         | 9545-008-027 | 1   |
| *   | Lock washer-exttooth,#10              | 8641-582-006 | 1   |
| 5   | Terminal block assembly-power         | 9897-026-002 | 1   |
| 6   | Terminal block assembly-power         | 9897-026-001 | 2   |
| *   | Screw-panhdc, #8abx1/2                | 9545-045-012 | 6   |
| 7   | Transformer                           | 8711-013-001 | 1   |
| *   | Screw-hxwshrundrcuthd,10abx3/8        | 9545-008-024 | 4   |
| 8   | Controls assy-ignition                | 9857-182-001 | 2   |
| *   | Screw-hxwshd,10abx3/4                 | 9545-008-018 | 4   |
| 9   | Wireasy-high voltage,#8,18 1/2"       | 9631-403-008 | 1   |
| 10  | Wireasy-high voltage,#7,29 1/4"       | 9631-403-009 | 1   |
| 11  | Wiring harness-ignitioncontrol Upper  | 9627-867-005 | 1   |
| 12  | Wiring harness-ignition control lower | 9627-867-006 | 1   |
| *   | Plug-plastic,7/8"                     | 9456-041-006 | 2   |
| *   | Bushing-wire,7/8                      | 9053-067-002 | 4   |
| *   | Connector-conduit,3/8",str            | 8653-068-003 | 1   |
| 13  | Fuse holder assembly                  | 9200-001-002 | 3   |
| *   | Fuse-1.5a,fast,1/4x1-1/4              | 8636-018-001 | 2   |
| *   | Fuse-2.5a,fast,1/4x1-1/4              | 8636-018-004 | 1   |
| 14  | Relay-motor,30amp,24vac               | 5192-299-002 | 2   |
| *   | Screw-panhdc, #8abx1/2                | 9545-045-012 | 4   |
| *   | Wireasy-red/blk,#9,14"                | 8220-062-036 | 1   |
| *   | Wireasy-red/wht,#10,14"               | 8220-062-037 | 1   |
| *   | Wireasy-wht,#11,14"                   | 8220-062-038 | 2   |
| 15  | Bracket-power block                   | 9029-202-001 | 1   |
| *   | Screw-hxwshrundrcuthd,10abx3/8        | 9545-008-024 | 2   |
| *   | Terminal block asy-power,4pole        | 9897-035-001 | 1   |
| *   | Screw-hxwshrundrcuthd,10abx3/8        | 9545-008-024 | 2   |
| *   | Strip-marker,terminal                 | 9558-029-003 | 1   |
| 16  | Wiring harness-power,main,fork        | 9627-859-003 | 1   |
| 17  | Wiring harness-mainex tension         | 9627-863-001 | 1   |
| 18  | Standoff-wires addlew/arrowhead       | 9527-007-001 | 22  |
| 19  | Wiring harness-motor ext,w/fork Lower | 9627-864-006 | 1   |
| 20  | Wiring harness-motor extension Upper  | 9627-864-011 | 1   |
| *   | Screw-pnhdc,6bx3/8                    | 9545-031-005 | 4   |
| *   | Screw-hxwsrhds1,10-32tx1/2grn         | 9545-008-027 | 2   |
| *   | Lockwasher-exttooth,#10               | 8641-582-006 | 2   |
| 21  | Wireasy-red,37"                       | 8220-095-011 | 1   |
| 22  | Wireasy-blu,42"                       | 8220-095-012 | 1   |
| 23  | Wireasy-wht,22"                       | 8220-095-048 | 1   |
| 24  | Wireasy-blk,#30,45"                   | 8220-095-046 | 1   |

# Control Assembly Group

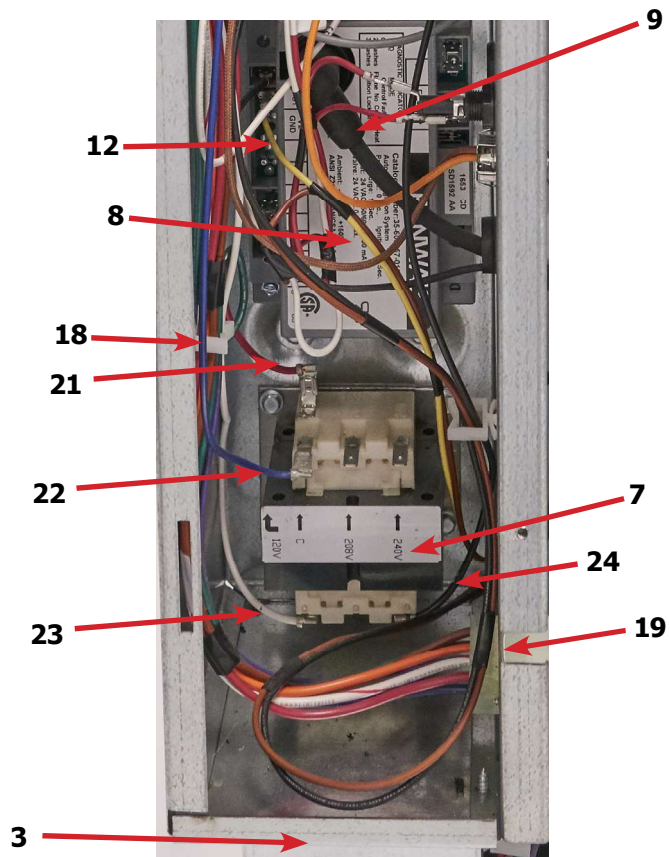
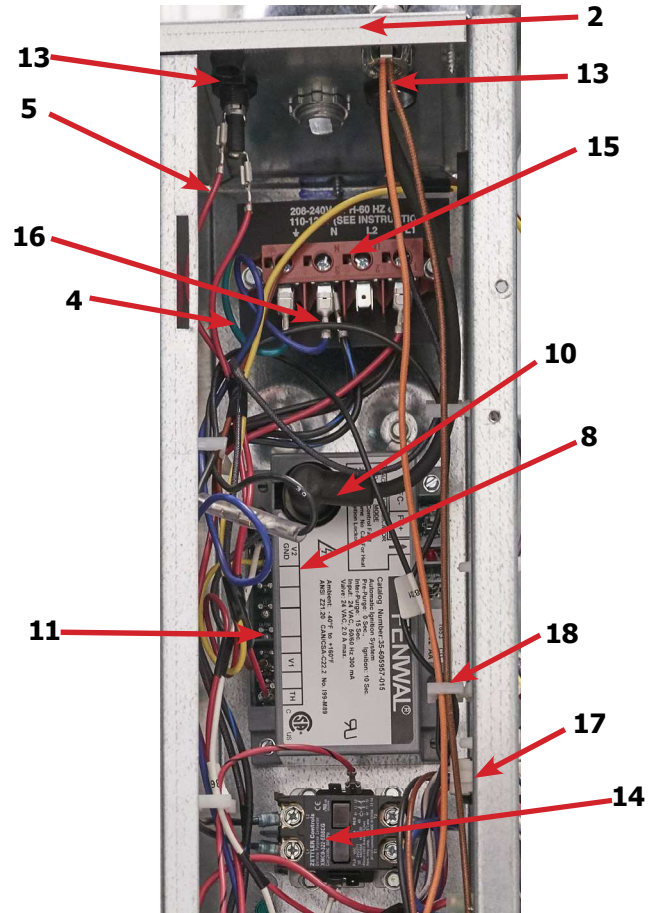
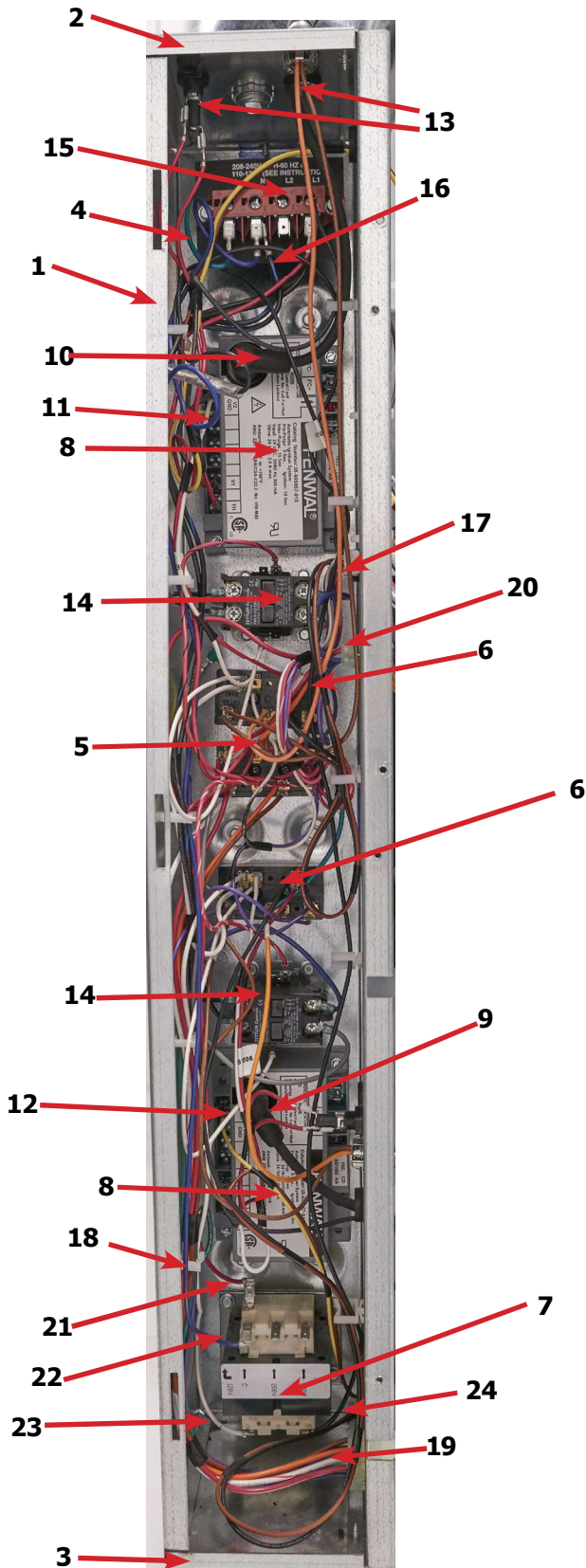

# Wire Harness

| Key | Description                   | T-20x2       | QTY |
|-----|-------------------------------|--------------|-----|
| *   | Wireharness-overtmp/airswitch | 9627-861-002 | 2   |
| *   | Wireharness-main,dry,t-20x2   | 9627-911-006 | 1   |
| *   | Wiringharness-heatsensor      | 9627-855-003 | 1   |
| *   | Wireasy-org,37"               | 8220-095-049 | 1   |
| *   | Wireasy-brn,37"               | 8220-095-050 | 1   |
| *   | Wireasy-org,#14,24"           | 8220-095-040 | 1   |
| *   | Wireasy-brn,#15,24"           | 8220-095-041 | 1   |
| *   | Wireasy-yel,47/8"             | 8220-001-466 | 2   |
| *   | Wireasy-grn/yel,#16,24"       | 8220-137-001 | 1   |
| *   | Wiringharness-ignitioncontrol | 9627-867-005 | 1   |
| *   | Wiringharness-ignitioncontrol | 9627-867-006 | 1   |
| *   | Wiringharness-power,main,fork | 9627-859-003 | 1   |
| *   | Wiringharness-mainextension   | 9627-863-001 | 1   |
| *   | Wiringharness-motorext,w/fork | 9627-864-006 | 1   |
| *   | Wiringharness-motorextension  | 9627-864-011 | 1   |
| *   | Wireasy-grn/yel,7"            | 8220-137-002 | 1   |
| *   | Wireasy-red/blk,#9,14"        | 8220-062-036 | 1   |
| *   | Wireasy-red/wht,#10,14"       | 8220-062-037 | 1   |
| *   | Wireasy-wht,#11,14"           | 8220-062-038 | 2   |
| *   | Wireasy-red,37"               | 8220-095-011 | 1   |
| *   | Wireasy-blu,42"               | 8220-095-012 | 1   |
| *   | Wireasy-wht,22"               | 8220-095-048 | 1   |
| *   | Wireasy-blk,#30,45"           | 8220-095-046 | 1   |



# Coin Handling Group

| Key | Description  | Part Number  | Qty |
|-----|--|--------------|-----|
|     | Coin Acceptor, Optical, US Quarter                 | 9021-092-002 | 1   |
| *   | Retainer, Coin Acceptor                            | 9486-149-001 | 1   |
| *   | Screw, Torx  | 9545-053-002 | 4   |
| 1   | Switch Assembly, Optical Sensor                    | 9801-099-003 | 1   |
| *   | Harness, Acceptor Mechanical (Control to Acceptor) | 9627-783-003 | 1   |
| *   | Coin Vault   | 9942-038-005 | 1   |
| *   | Screw, 10AB X 3/8                                  | 9545-008-024 | 2   |
| *   | Plateasy-coinvaultmounting                         | 9982-338-001 | 1   |

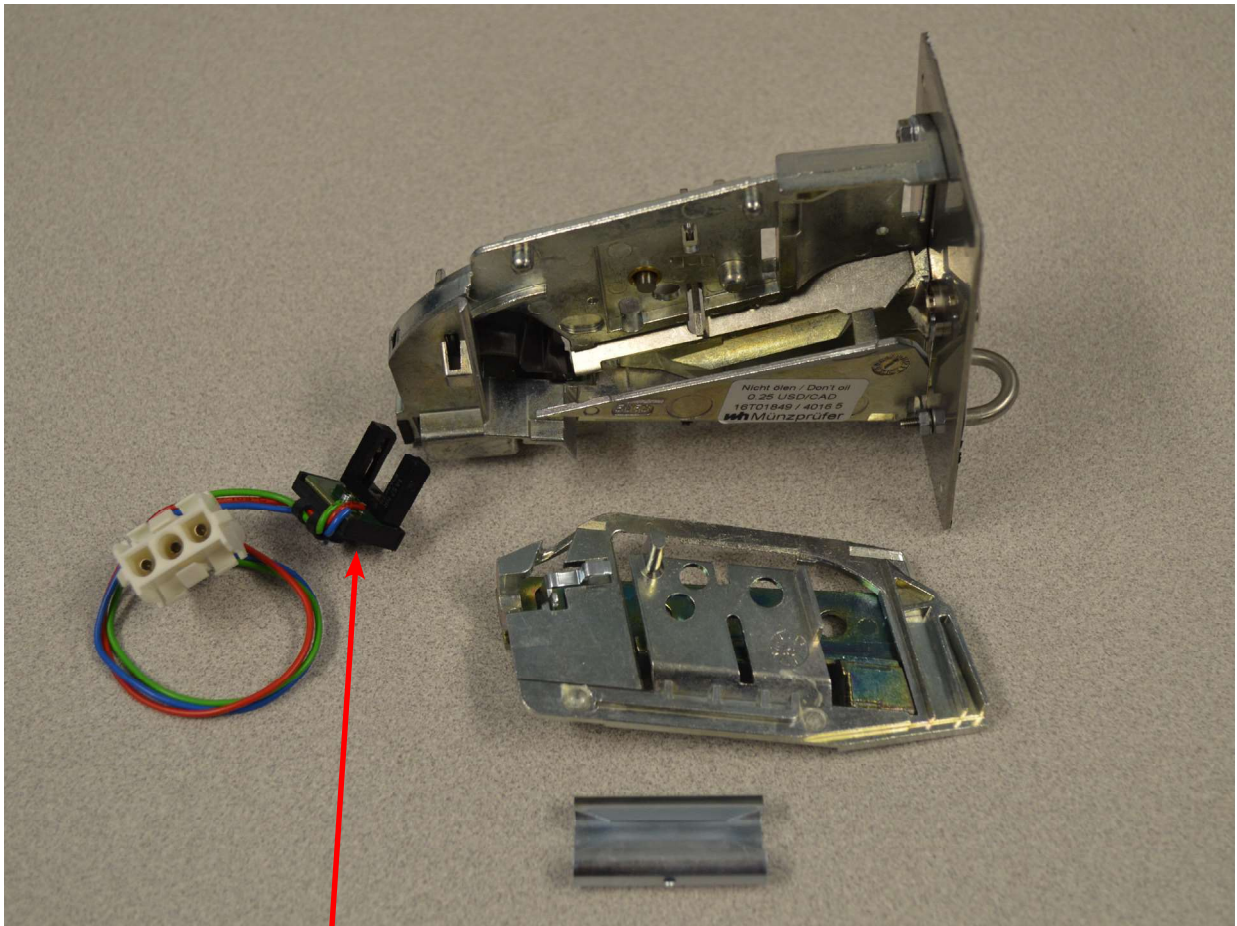

1

# Wiring Diagram for DC20x2

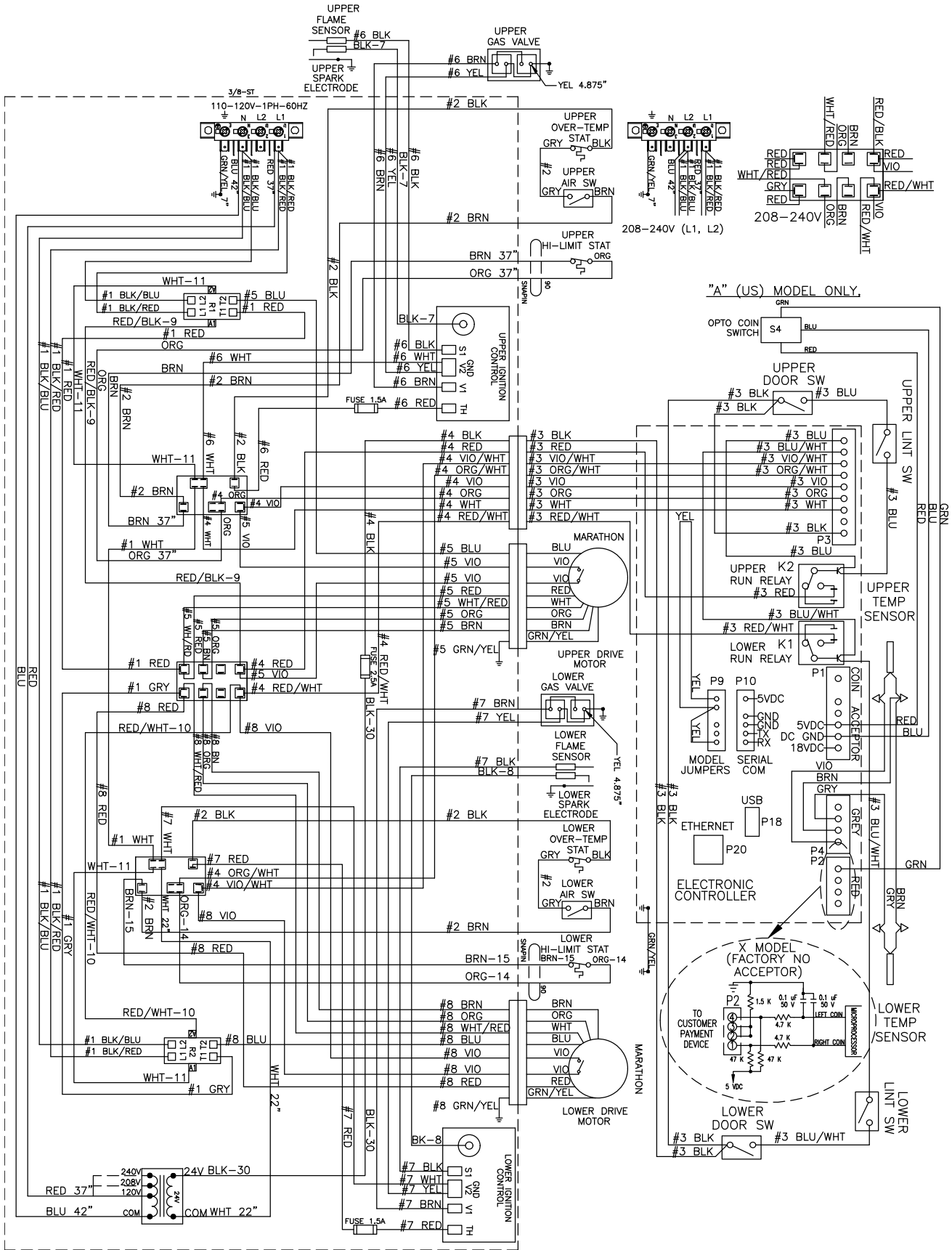

9506-836-001PR WIRING DIAGRAM DC20X2N\_-15\_C\_X-

**IMPORTANT: RETAIN THIS ELECTRICAL DIAGRAM FOR SERVICE.**

# Wiring Schematic for DC20x2

**NOTES:**

1. DOOR SWITCHES ARE N.O., DOOR IS CLOSED. SWITCHES CLOSED WHEN DOOR IS CLOSED.
2. MOTOR RUN RELAY CONTACT WILL CLOSE WHEN THE COIN COUNT IS SATISFIED, THE DOOR CLOSED AND THE START BUTTON PRESSED.
3. REFER TO OWNERS MANUAL FOR DESCRIPTION OF OPERATION AND REQUIREMENTS FOR HEATING CIRCUIT.

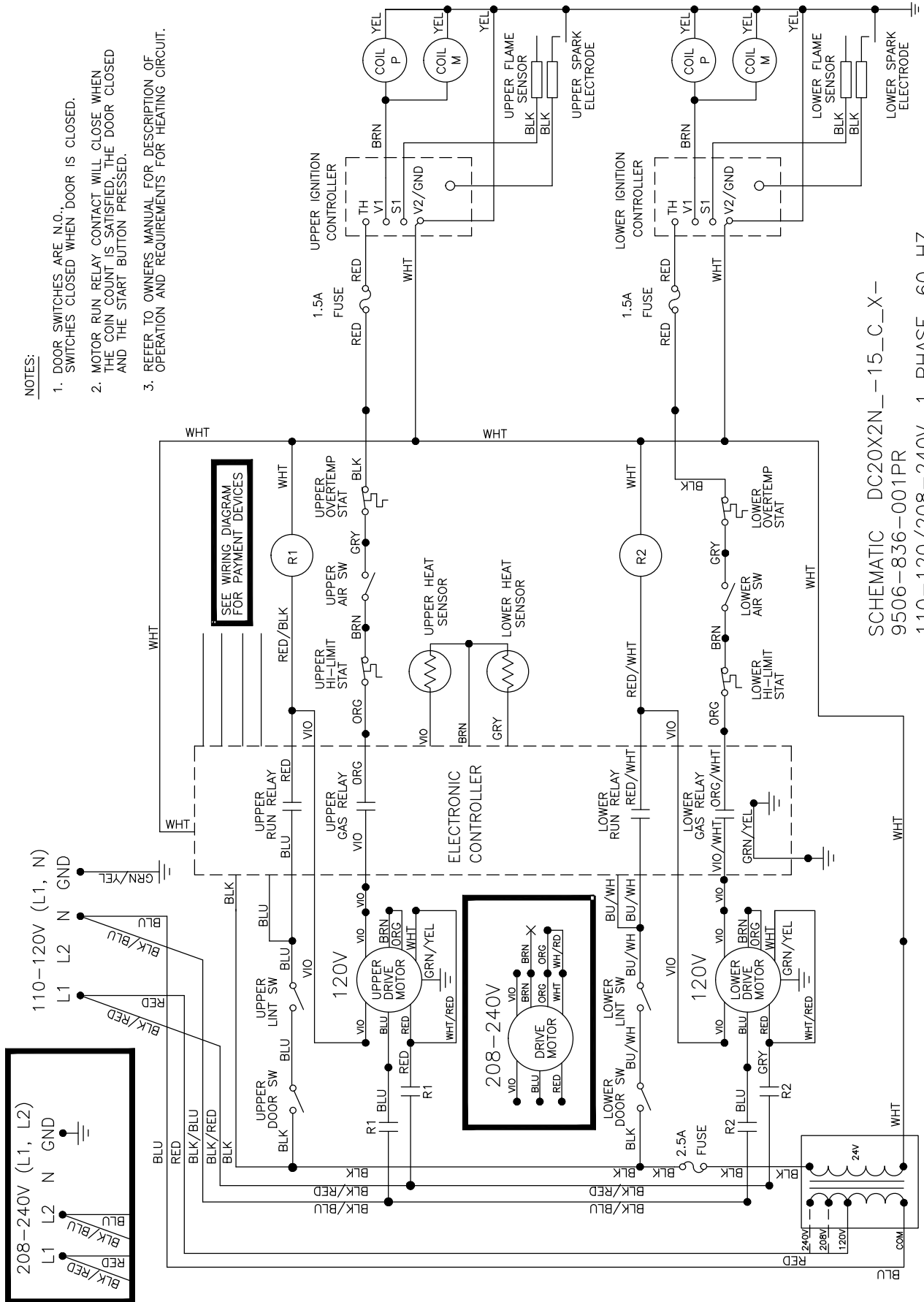

SCHEMATIC DC20X2N\_15\_C\_X-  
9506-836-001PR  
110-120/208-240V, 1 PHASE, 60 HZ

**IMPORTANT: RETAIN THIS ELECTRICAL SCHEMATIC FOR SERVICE.**



---

# **Section: 8**

## Maintenance

---

# Preventative Maintenance

## Daily

- Step 1:** Clean the lint screen free of lint and other debris. Use a soft brush and Hot water if necessary.
- Step 2:** Check the lint screen for tears. Replace if necessary.
- Step 3:** Clean lint from the lint screen compartment.
- Step 4:** Inspect felt seal on lint screen assembly, replace if needed.

## Monthly

- Step 1:** Remove lint accumulation from the end bells of the motor.
- Step 2:** Remove lint accumulation from front control area.
- Step 3:** Remove lint and dirt accumulation from the top of the dryer and all areas above, below, and around the burners and burner housing. Failure to keep this portion of the dryer clean can lead to a build-up of lint creating a fire hazard.
- Step 4:** Remove and clean coin acceptors. (Vended Models Only)

## Quarterly

- Step 1:** Check the belts for looseness, wear, or fraying.
- Step 2:** Inspect the gasket of the door glass for excessive wear.
- Step 3:** Check tightness of all fasteners holding parts to support channel.
- Step 4:** Check tightness of all set screws.
- Step 5:** Remove the air flow switch assembly and check the tumbler thru-bolts for tightness.
- Step 6:** Apply a few drops of oil to pivot pins and the tension arms where in contact with each other.

## Semi-Annually

- Step 1:** Remove and clean the main burners.
- Step 2:** Remove all orifices and examine for dirt and hole obstruction.
- Step 3:** Remove all lint accumulation. Remove the front panel and the lint screen housing and remove lint accumulation.

## Annually

- Step 1:** Check the intermediate pulley bearings for wear.
- Step 2:** Check and remove any lint accumulation from the exhaust system including recirculation chambers if applicable.
- Step 3:** Grease the bearings and the shaft of the intermediate pulley. Use an Alemite grease gun and Molykote BR2-S grease. (Where applicable)

---

# **Section: 9**

Voltage

Conversion

## Instructions - Convert a Dual Voltage Stack Dryer from 120V to 208-240V (No Neutral Required)

1. Remove incoming power from the dryer. Use a known working voltmeter to check power.
2. Remove the cover of the control box assembly from the dryer using a 5/16" wrench.
3. Move the black/blue wire AND the blue wire from the N position of the main power terminal block to the L2 position of the main power terminal block in the upper control box assembly. See figure below.
4. Move the white/red wire of the upper motor harness to an upper inner left terminal in the middle terminal block in the lower control box assembly. See figure below.
5. Move the orange wire of the upper motor harness to an upper inner left terminal in the middle terminal block in the lower control box assembly. See figure below.
6. Move the white/red wire of the lower motor harness to a lower inner left terminal in the middle terminal block in the lower control box assembly. See figure below.
7. Move the orange wire of the lower motor harness to a lower inner left terminal in the middle terminal block in the lower control box assembly. See figure below.

Conversion instructions continued on next page.

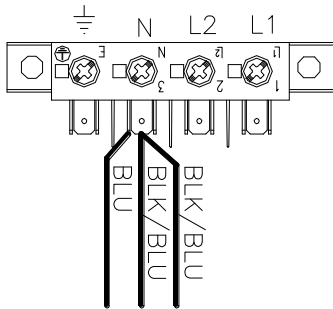

110–120V (L1, N)

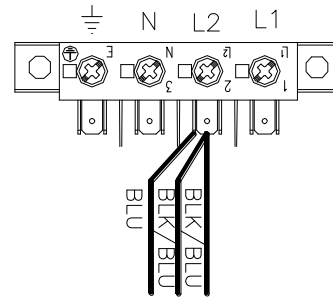
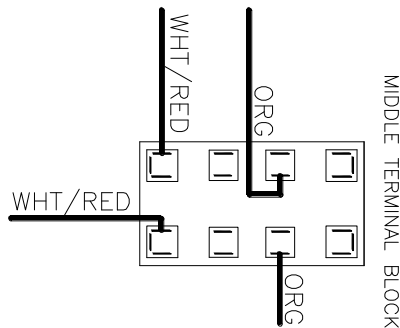

208–240V (L1, L2)

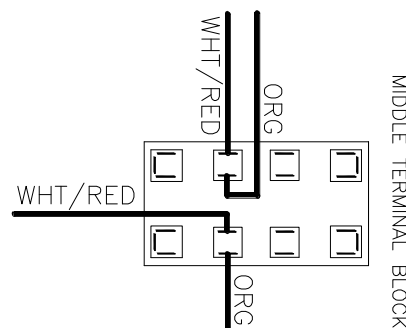



8. Move the red wire from the 120V tap on the transformer found in the bottom of control box to the required voltage tap based on actual supply voltage measurement. See figure below.

CONTROL TRANSFORMER CONNECTIONS  
AS VIEWED FROM SIDE OF TRANSFORMER

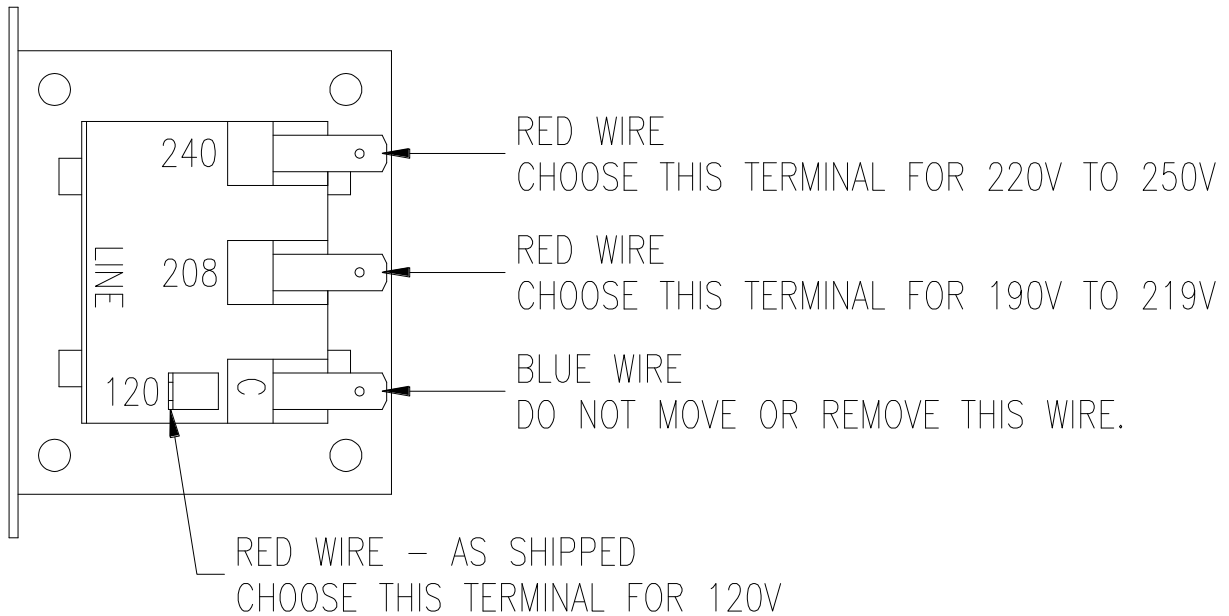

9. Reconnect power to the dryer and test to ensure proper operation; one line voltage to L1, one line voltage to L2 and the earth ground to E.
10. Reinstall the cover of the control box assembly on the dryer using a 5/16" wrench.



---

# **Section: 10**

50 hZ  
Models

---

## 50HZ Wiring Schematic Dryer Idle - No Coins Added

Top Dryer Used For This Example

230 VAC 50 HZ is supplied to the Main Power Terminal Block and passes through a In-line Noise Filter and comes out on BLK/RED and BLK/BLU wire. 230 VAC now passes to a Multitap Control Step Down Transformer and also passes to the Motor Control Relay (R1&R2). When there is power to the dryer the Computer Board will be powered and the display lighted from the 24 VAC secondary side of Control Step Down Transformer. 24 VAC from here is also on one side of the door switch on a black wire. Closing the loading door allows 24 VAC to pass on to the Computer Board on two blue wires. One blue wire makes 24 VAC available to one side of the Motor Run Relay on Computer Board. The other blue wire provides a 24 VAC signal to the Computer Board telling it that the door is closed and door light on the computer board should be illuminated.

## Coins Added - Motor Starting and Running

Top Dryer Used For This Example

As each coin is added the Coin Switch closes and completes a circuit to the Computer Board. The Computer Board counts these signals and registers them against time. The time will display once the Start Button for Upper or Lower is pushed. When the Start Button is pushed again the Computer Board Motor Run Relay closes on the computer. With this Relay closed, 24 VAC is supplied to the Motor Control Relay (R1) on the red wire and also a violet wire going down to motor. The motor LED on the computer board should be illuminated anytime the computer calls for the motor to operate. With (R1) engaged and 230 VAC at motor the Motor Start Switch in motor is drawn in to the start position. In this position the incoming power 230 VAC is supplied directly to the main run winding and through the Start Capacitor to the Auxiliary Winding (start winding). As the Motor comes up to speed, the centrifical switch inside motor opens the circuit to the Start Winding and closes the circuit to allow 24 VAC to pass to the Gas Relay on the Computer Board on the other violet wire. The heat circuit in the dryer can not operate if the motor is not running. The gas LED on the computer board will be illuminated when Computer Board calls for the heat after Motor Centrifical Switch has closed.

## Heat Circuit

Top Dryer Used For This Example

With the Drive Motor running and 24 VAC provided to the Computer Board Gas Relay, it will close if Computer Board senses programmed temperature is needed. The violet wire changes to an orange wire out of the Computer Board Gas Relay. When this relay closes it provides 24 VAC to the High Limit Thermostat. The High Limit Thermostat is normally closed. (It will open, turning off the heat circuit, if the dryer can't move enough air from problems such as an exhaust restriction or other problems.) 24 VAC now goes through to the normally open Air Switch (Sail Switch) on the brown wire. This switch is closed only if the dryer is running and has the correct air flow. With the dryer running and the Air Switch closed, 24 VAC is supplied to the normally closed upper manual reset Overtemp Thermostat on the gray wire and changes to the black wire out of switch and then changes to red wire and goes to the 1.5 amp in-line fuse that protects the Upper Ignition Controller (GREY BOX). With 24 VAC now supplied to the Upper Ignition Controller (GREY BOX) it will then send high voltage to the Spark Ignition Electrode via the High Voltage Lead Wire (this lead looks like an automotive spark plug wire). The Ignition Control Module (GREY BOX) simultaneously sends 24VAC to the Gas Valve Coil which open the Gas Valve and allows gas to pass through to the main burner. When ignition occurs the high voltage sparking stops and if Ignition Control Module (GREY BOX) gets a flame sense signal it will allow gas valve coil to remain energized and continue burner operation. If ignition does not occur, the Ignition Control Module (GREY BOX) will spark for 10 seconds before locking out.

---

## **Manual Reset Safety Shutoff Over-Temperature Thermostat**

Top Dryer Used For This Example

This thermostat is manually reset by pushing in the red button. The Over Temperature Thermostat is a safety backup for the entire Heat Circuit and located in the recirculation chamber area on the side of the burner housing. If the dryer over heats this Over Temperature Thermostat it opens the line to turn off the heat but leaves the Computer Board lighted and the drive motor powered and turning so the basket will cool down.

### **Cool Down**

Top Dryer Used For This Example

At the preprogrammed time (2 minutes factory setting--adjustable) the Computer Board will open the Gas Relay Contact. This allows the Drive Motor to continue to run but without heat. The gas light on the computer board should not be illuminated anytime the computer is in cool down. This Cool Down period allows the clothing (zippers, snaps, etc.) time to cool down to a temperature that is easily handled by customers.

### **End of Cycle**

Top Dryer Used For This Example

At the end of the cool down, the Computer Board opens the Upper Run Relay, which removes power from the Motor Control Relay (R1) and also removes power to the Drive Motor. The motor light on the computer board should no longer be illuminated. The Drive Motor and tumbler stops and the Computer Board display now flashes until the dryer loading door is opened. Once the dryer loading door is opened to remove the clothing the display goes back to vend price.

## DC20x2-39 Additional Part

| Key | Description                           | T-20x2       | QTY |
|-----|---------------------------------------|--------------|-----|
| *   | INFORMATIVE-DC20X2N_-39               | 6102-018-368 | 1   |
| *   | INFORMATIVE-MOUNTING LOCATIONS        | 6102-034-001 | 1   |
| *   | WIREASY-WHT,#6,11"                    | 8220-065-033 | 1   |
| *   | WIREASY-BLK,#5,40"                    | 8220-065-040 | 1   |
| *   | WIREASY-BLK/RED,#3,15"                | 8220-149-001 | 1   |
| *   | WIREASY-BLK/BLU,#4,19"                | 8220-149-002 | 1   |
| *   | LABEL-AUSSIE WARNING                  | 8502-698-001 | 1   |
| *   | LABEL-AUST GAS APPROVAL BADGE         | 8502-699-001 | 1   |
| *   | LABEL-WARNING,NATURALGAS              | 8502-770-001 | 1   |
| *   | INSTRUCTIONS-DRYINSTALL/START         | 8507-350-001 | 1   |
| *   | INSTRUCT-AUS ADDENDUM,CONTACT         | 8507-440-001 | 1   |
| *   | CONNECTOR-WIRE,INLINE,1/4"            | 8653-039-000 | 1   |
| *   | NIPPLE-1/2CLOSE,BLK                   | 8655-073-041 | 2   |
| 1   | TRANSFORMER-CONTROL                   | 8711-008-002 | 1   |
| 2   | BRACKET-AIRFLOW,SWITCH,50HZ           | 9029-174-002 | 2   |
| *   | NAMEPLATE-DEXTER,T-20X2,BLK           | 9412-251-001 | 1   |
| 3   | ORIFICE-MAIN BURNER,#43               | 9425-069-025 | 4   |
| *   | OVERLAY-DRAWER,FRT,BLK,W/TEXT         | 9435-053-003 | 2   |
| *   | OVERLAY-ESC,T-20X2,UP,COIN,BLK        | 9435-058-001 | 1   |
| *   | OVERLAY-ESCU,T-20X2,LWR,BLK           | 9435-060-001 | 1   |
|     | PLATE-COVER,COINACCEPT(MAKE)          | 9452-658-002 | 1   |
| 4   | PULLEY-MOTOR,50HZ                     | 9453-185-002 | 2   |
| *   | WIRINGLABEL-SCHEMATIC/DIAGRAM         | 9506-837-001 | 1   |
| *   | STRIP-MARKER,TERMINAL                 | 9558-029-004 | 1   |
| 5   | WIRING HARNESS-POWER MAIN,W/FORK      | 9627-859-002 | 1   |
| 6   | WIRING HARNESS-IGNITION CONTROL Upper | 9627-867-001 | 1   |
| 7   | WIRINGHARNESS-IGNITION CONTROL Lower  | 9627-867-002 | 1   |
| 8   | KIT-HONEYWELL VR86 VALVEFLG,1/2"      | 9732-162-001 | 4   |
| 9   | SWITCH ASSEMBLY-AIRFLOW,50HZ          | 9801-095-002 | 2   |
| 10  | CONTROL ASSEMBLY-GAS                  | 9857-132-004 | 2   |
| *   | CONTRLASY-STKCOIN,1.5,24V,BLK         | 9857-198-004 | 1   |
| *   | CNTL ASY-IGN,T-20X2,GAS,COIN-39       | 9857-250-002 | 1   |
| *   | DRAWER ASSY-LINT,COIN,BLK,W/TXT       | 9866-008-004 | 2   |

7

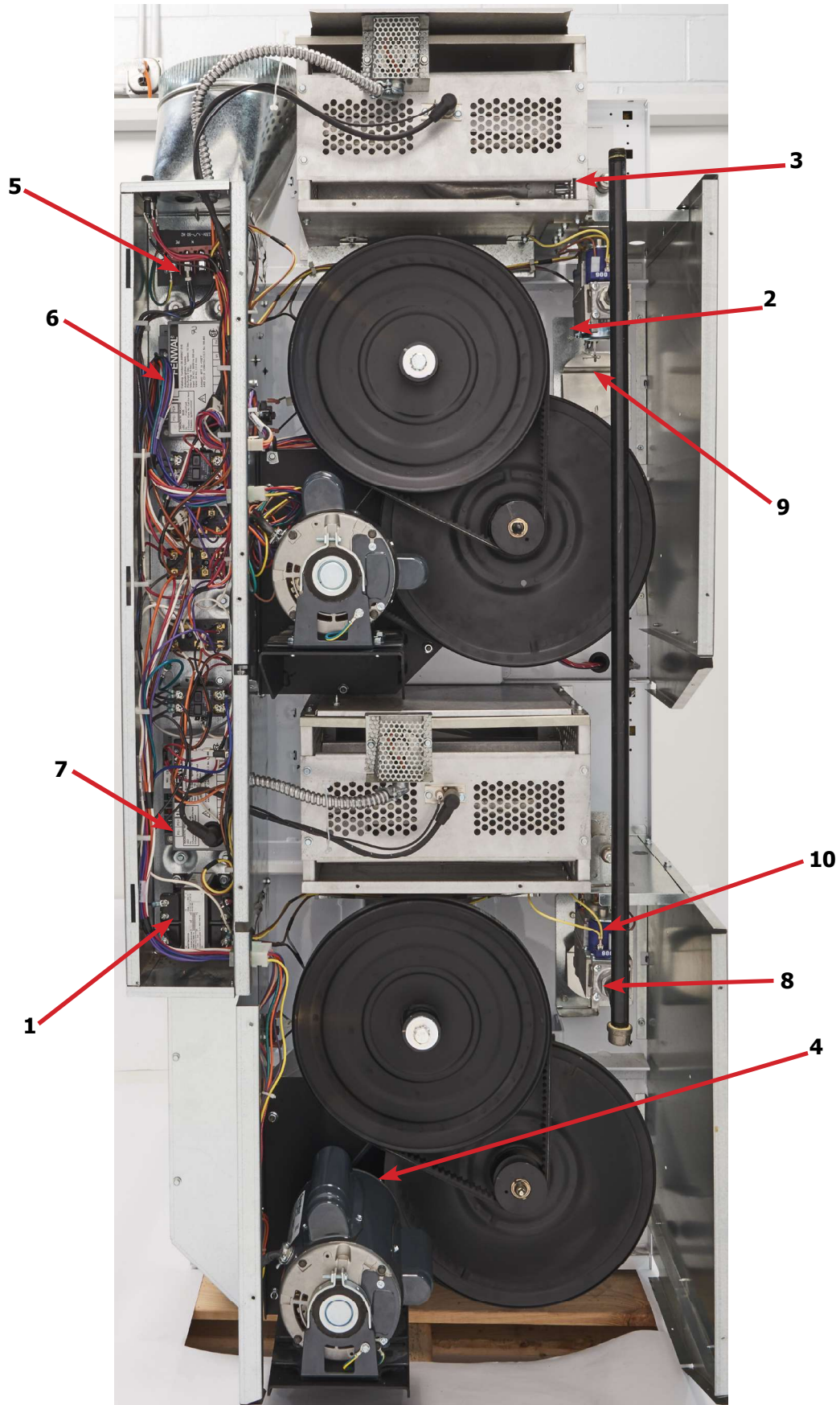

# Wiring Schematic for DC20x2-39

**NOTES:**

1. DOOR SWITCHES ARE N.O., SWITCHES CLOSED WHEN DOOR IS CLOSED.
2. MOTOR RUN RELAY CONTACT WILL CLOSE WHEN THE COIN COUNT IS SATISFIED, THE DOOR CLOSED AND THE START BUTTON PRESSED.
3. REFER TO OWNERS MANUAL FOR DESCRIPTION OF OPERATION AND REQUIREMENTS FOR HEATING CIRCUIT.

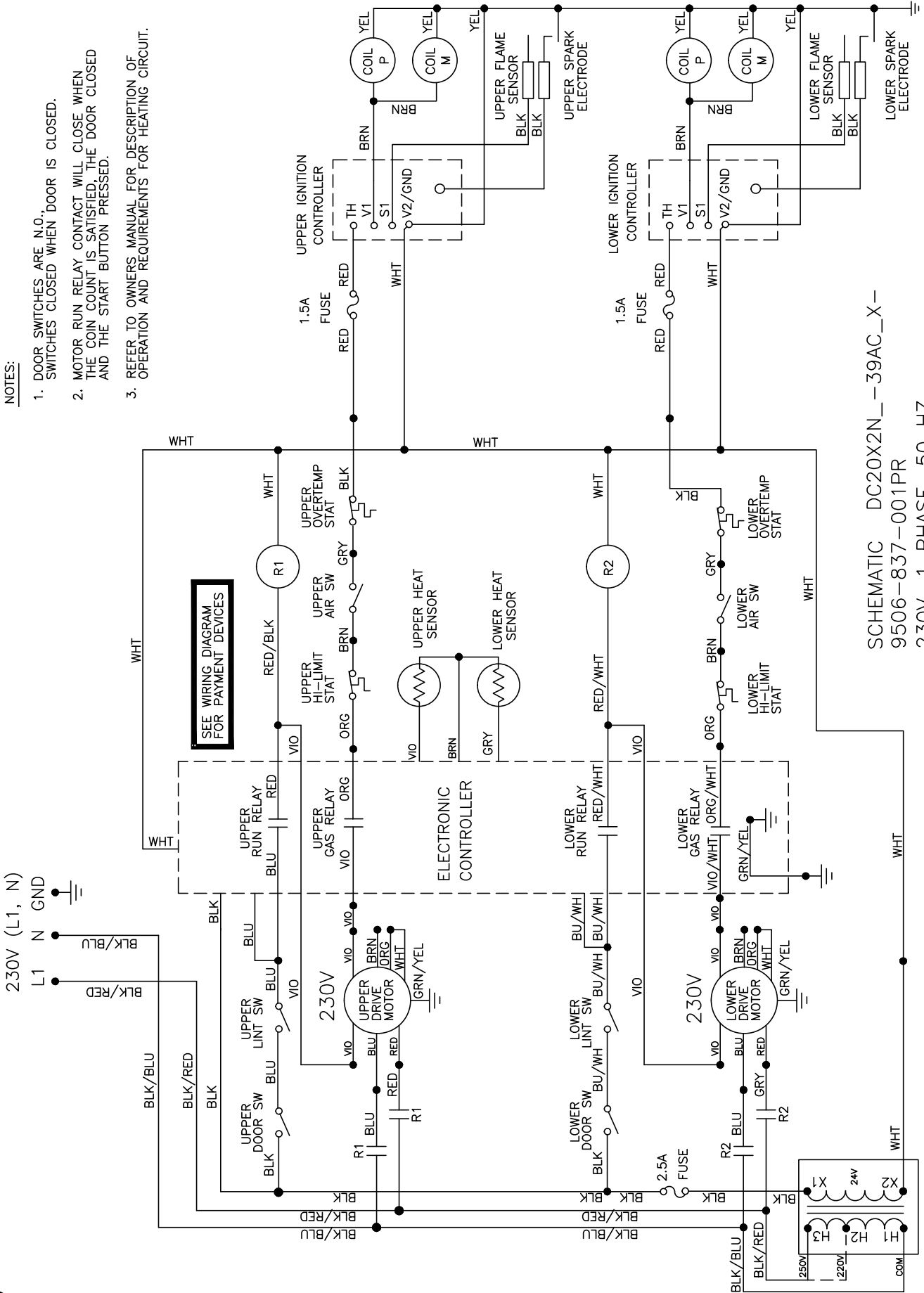

SCHEMATIC DC20X2N\_-39AC\_X-  
 9506-837-001PR  
 230V, 1 PHASE, 50 HZ

**IMPORTANT: RETAIN THIS ELECTRICAL SCHEMATIC FOR SERVICE.**



# Wiring Diagram for DC20x2-39

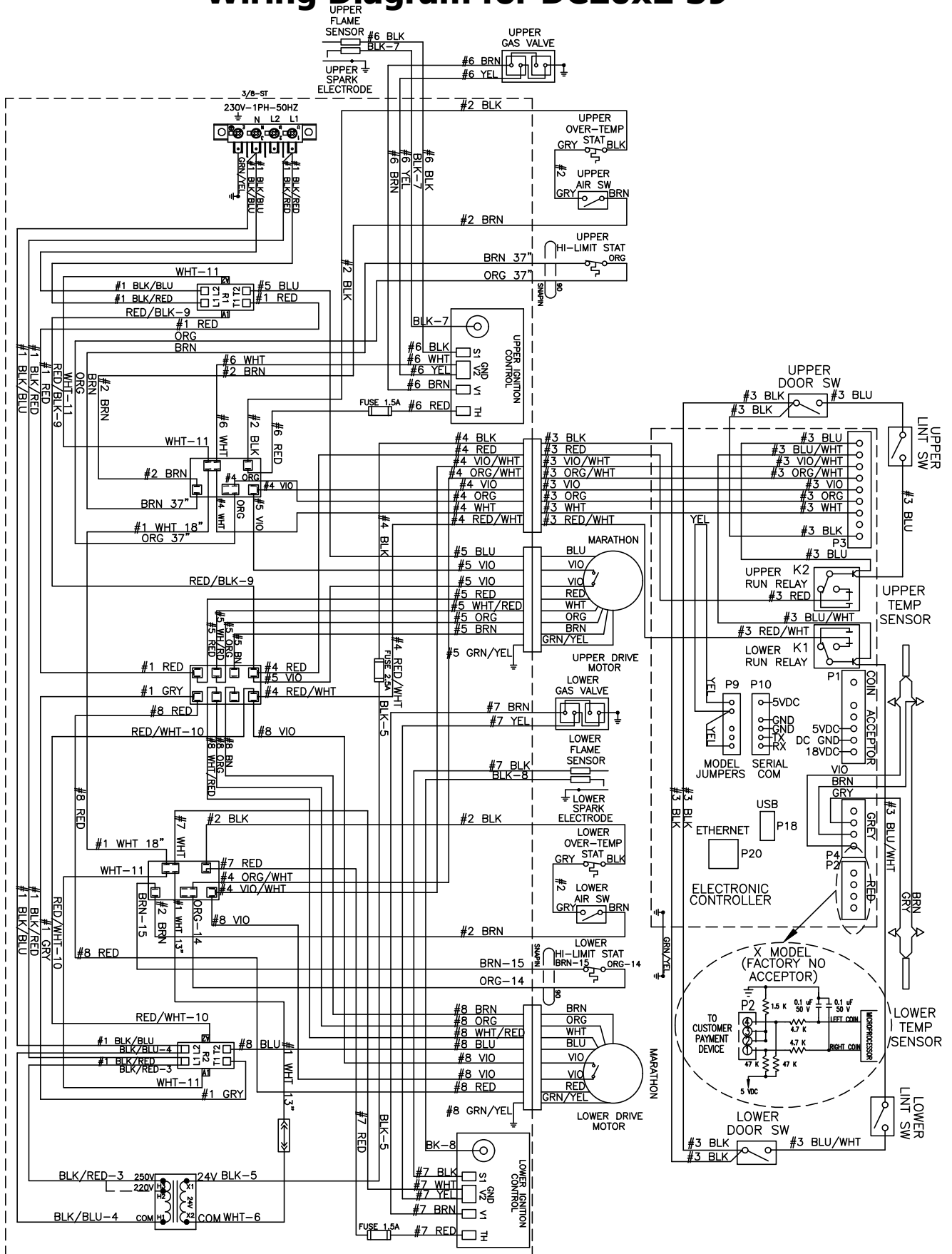

9506-837-001PR WIRING DIAGRAM DC20X2N\_-39AC\_X-

**IMPORTANT: RETAIN THIS ELECTRICAL DIAGRAM FOR SERVICE.**

---

# Notes

Lined area for notes.